



**THE DATASHEET OF  
LT1012CN8#PBF**



# Picoamp Input Current, Microvolt Offset, Low Noise Op Amp

## FEATURES

- OP-07 Type Performance:
  - at 1/8th of OP-07's Supply Current
  - at 1/20th of OP-07's Bias and Offset Currents
- *Guaranteed* Offset Voltage: 25 $\mu$ V Max
- *Guaranteed* Bias Current: 100pA Max
- *Guaranteed* Drift: 0.6 $\mu$ V/ $^{\circ}$ C Max
- Low Noise, 0.1Hz to 10Hz: 0.5 $\mu$ V<sub>P-P</sub>
- *Guaranteed* Low Supply Current: 500 $\mu$ A Max
- *Guaranteed* CMRR: 114dB Min
- *Guaranteed* PSRR: 114dB Min
- *Guaranteed* Operation at  $\pm 1.2$ V Supplies

## APPLICATIONS

- Replaces OP-07 While Saving Power
- Precision Instrumentation
- Charge Integrators
- Wide Dynamic Range Logarithmic Amplifiers
- Light Meters
- Low Frequency Active Filters
- Thermocouple Amplifiers

## DESCRIPTION

The LT<sup>®</sup>1012 is an internally compensated universal precision operational amplifier which can be used in practically all precision applications. The LT1012 combines picoampere bias currents (which are maintained over the full  $-55^{\circ}$ C to  $125^{\circ}$ C temperature range), microvolt offset voltage (and low drift with time and temperature), low voltage and current noise, and low power dissipation. The LT1012 achieves precision operation on two Ni-Cad batteries with 1mW of power dissipation. Extremely high common mode and power supply rejection ratios, practically unmeasurable warm-up drift, and the ability to deliver 5mA load current with a voltage gain of one million round out the LT1012's superb precision specifications.

The all around excellence of the LT1012 eliminates the necessity of the time consuming error analysis procedure of precision system design in many applications; the LT1012 can be stocked as the universal internally compensated precision op amp.

 LTC and LT are registered trademarks of Linear Technology Corporation. Protected by U. S. patents 4,575,685 and 4,775,884

## TYPICAL APPLICATION

### $\pm 250$ V Common Mode Range Instrumentation Amplifier ( $A_v = 1$ )

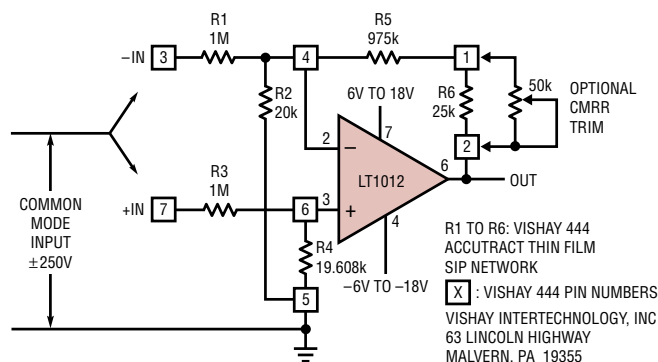

COMMON MODE REJECTION RATIO = 74dB (RESISTOR LIMITED)  
 WITH OPTIONAL TRIM = 130dB  
 OUTPUT OFFSET (TRIMMABLE TO ZERO) = 500 $\mu$ V  
 OUTPUT OFFSET DRIFT = 10 $\mu$ V/ $^{\circ}$ C  
 INPUT RESISTANCE = 1M

LT1012A-TA01

### Typical Distribution of Input Offset Voltage

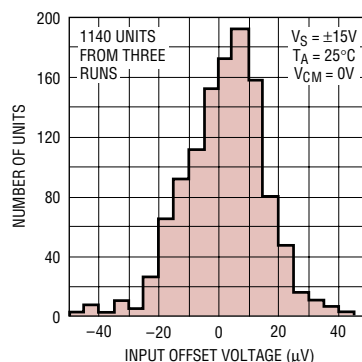

LT1012A-TA02

# LT1012A/LT1012

## ABSOLUTE MAXIMUM RATINGS (Note 1)

Supply Voltage .....  $\pm 20V$   
 Differential Input Current (Note 1) .....  $\pm 10mA$   
 Input Voltage .....  $\pm 20V$   
 Output Short Circuit Duration ..... Indefinite

Operating Temperature Range  
 LT1012AM/LT1012M (**OBSOLETE**)....  $-55^{\circ}C$  to  $125^{\circ}C$   
 LT1012I/LT1012AI .....  $-40^{\circ}C$  to  $85^{\circ}C$   
 LT1012AC/LT1012C  
 LT1012D/LT1012S8 .....  $0^{\circ}C$  to  $70^{\circ}C$   
 Storage Temperature Range .....  $-65^{\circ}C$  to  $150^{\circ}C$   
 Lead Temperature (Soldering, 10 sec).....  $300^{\circ}C$

## PACKAGE/ORDER INFORMATION

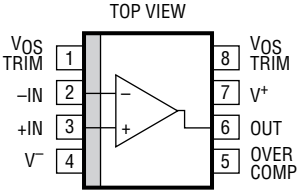
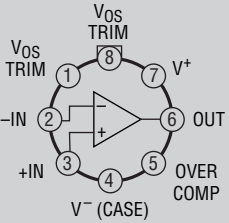
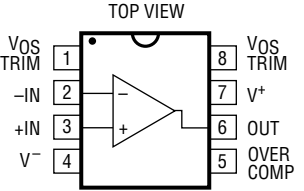
 <p>S8 PACKAGE 8-LEAD PLASTIC SO <math>T_{JMAX} = 100^{\circ}C, \theta_{JA} = 170^{\circ}C/W</math></p>	<p>TOP VIEW</p>  <p>H PACKAGE 8-LEAD TO-5 METAL CAN <math>T_{JMAX} = 150^{\circ}C, \theta_{JA} = 150^{\circ}C/W, \theta_{JC} = 45^{\circ}C/W</math></p>	 <p>N8 PACKAGE 8-LEAD PDIP <math>T_{JMAX} = 100^{\circ}C, \theta_{JA} = 130^{\circ}C/W</math></p>
ORDER PART NUMBER	ORDER PART NUMBER	ORDER PART NUMBER
LT1012S8 LT1012IS8 LT1012ACS8 LT1012AIS8	LT1012AMH LT1012MH LT1012ACH LT1012CH LT1012DH	LT1012ACN8 LT1012AIN8 LT1012CN8 LT1012DN8 LT1012IN8
S8 PART MARKING	<b>OBSOLETE PACKAGE</b> Consider the S8 or N8 Packages for Alternate Source	
1012 1012I 1012A 1012AI		

Consult LTC Marketing for parts specified with wider operating temperature ranges.

**ELECTRICAL CHARACTERISTICS**

$V_S = \pm 15V$ ,  $V_{CM} = 0V$ ,  $T_A = 25^\circ C$ , unless otherwise noted.

SYMBOL	PARAMETER	CONDITIONS	LT1012AM/AC/AI			LT1012M/I			LT1012C			UNITS
			MIN	TYP	MAX	MIN	TYP	MAX	MIN	TYP	MAX	
$V_{OS}$	Input Offset Voltage	(Note 3)		8	25		8	35		10	50	$\mu V$
				20	90		20	90		25	120	$\mu V$
	Long Term Input Offset Voltage Stability			0.3			0.3			0.3		$\mu V/month$
$I_{OS}$	Input Offset Current	(Note 3)		15	100		15	100		20	150	$\mu A$
				25	150		25	150		30	200	$\mu A$
$I_B$	Input Bias Current	(Note 3)		$\pm 25$	$\pm 100$		$\pm 25$	$\pm 100$		$\pm 30$	$\pm 150$	$\mu A$
				$\pm 35$	$\pm 150$		$\pm 35$	$\pm 150$		$\pm 40$	$\pm 200$	$\mu A$
$e_n$	Input Noise Voltage	0.1Hz to 10Hz		0.5			0.5			0.5		$\mu V_{P-P}$
$e_n$	Input Noise Voltage Density	$f_0 = 10Hz$ (Note 4)		17	30		17	30		17	30	$nV/\sqrt{Hz}$
		$f_0 = 1000Hz$ (Note 5)		14	22		14	22		14	22	$nV/\sqrt{Hz}$
$i_n$	Input Noise Current Density	$f_0 = 10Hz$		20			20			20		$fA/\sqrt{Hz}$
$A_{VOL}$	Large Signal Voltage Gain	$V_{OUT} = \pm 12V, R_L \geq 10k\Omega$	300	2000		300	2000		200	2000		$V/mV$
		$V_{OUT} = \pm 10V, R_L \geq 2k\Omega$	300	1000		200	1000		200	1000		$V/mV$
CMRR	Common Mode Rejection Ratio	$V_{CM} = \pm 13.5V$	114	132		114	132		110	132		dB
PSRR	Power Supply Rejection Ratio	$V_S = \pm 1.2V$ to $\pm 20V$	114	132		114	132		110	132		dB
	Input Voltage Range		$\pm 13.5$	$\pm 14$		$\pm 13.5$	$\pm 14$		$\pm 13.5$	$\pm 14$		V
$V_{OUT}$	Output Voltage Swing	$R_L = 10k\Omega$	$\pm 13$	$\pm 14$		$\pm 13$	$\pm 14$		$\pm 13$	$\pm 14$		V
	Slew Rate		0.1	0.2		0.1	0.2		0.1	0.2		$V/\mu s$
$I_S$	Supply Current	(Note 3)		370	500		380			380		$\mu A$
				380	600		380	600		380	600	$\mu A$

# LT1012A/LT1012

## ELECTRICAL CHARACTERISTICS

$V_S = \pm 15V$ ,  $V_{CM} = 0V$ ,  $T_A = 25^\circ C$ , unless otherwise noted.

SYMBOL	PARAMETER	CONDITIONS	LT1012D			LT1012S8			UNITS
			MIN	TYP	MAX	MIN	TYP	MAX	
$V_{OS}$	Input Offset Voltage	(Note 3)		12 25	60		15 25	120 180	$\mu V$ $\mu V$
	Long Term Input Offset Voltage Stability			0.3			0.4		$\mu V/month$
$I_{OS}$	Input Offset Current	(Note 3)		20 30	150		50 60	280 380	$\rho A$ $\rho A$
	Input Bias Current	(Note 3)		$\pm 30$ $\pm 40$	$\pm 150$		$\pm 80$ $\pm 120$	$\pm 300$ $\pm 400$	$\rho A$ $\rho A$
$e_n$	Input Noise Voltage	0.1Hz to 10Hz		0.5			0.5		$\mu V_{p-p}$
$e_n$	Input Noise Voltage Density	$f_0 = 10Hz$ (Note 5)		17	30		17	30	$nV/\sqrt{Hz}$
		$f_0 = 1000Hz$ (Note 5)		14	22		14	22	$nV/\sqrt{Hz}$
$i_n$	Input Noise Current Density	$f_0 = 10Hz$		20			20		$fA/\sqrt{Hz}$
$A_{VOL}$	Large-Signal Voltage Gain	$V_{OUT} = \pm 12V, R_L \geq 10k\Omega$	200	2000		200	2000		$V/mV$
		$V_{OUT} = \pm 10V, R_L \geq 2k\Omega$	200	1000		120	1000		$V/mV$
CMRR	Common Mode Rejection Ratio	$V_{CM} = \pm 13.5V$	110	132		110	132		dB
PSRR	Power Supply Rejection Ratio	$V_S = \pm 1.2V$ to $\pm 20V$	110	132		110	132		dB
	Input Voltage Range		$\pm 13.5$	$\pm 14.0$		$\pm 13.5$	$\pm 14.0$		V
$V_{OUT}$	Output Voltage Swing	$R_L = 10k\Omega$	$\pm 13$	$\pm 14$		$\pm 13$	$\pm 14$		V
	Slew Rate		0.1	0.2		0.1	0.2		$V/\mu s$
$I_S$	Supply Current	(Note 3)		380	600		380	600	$\mu A$

**ELECTRICAL CHARACTERISTICS** The ● denotes the specifications which apply over the full operating temperature range of  $-55^{\circ}\text{C} \leq T_A \leq 125^{\circ}\text{C}$  for LT1012AM and LT1012M, and  $-40^{\circ}\text{C} \leq T_A \leq 85^{\circ}\text{C}$  for LT1012AI and LT1012I.  $V_S = \pm 15\text{V}$ ,  $V_{CM} = 0\text{V}$ , unless otherwise noted.

SYMBOL	PARAMETER	CONDITIONS	LT1012AM/AI			LT1012M/I			UNITS
			MIN	TYP	MAX	MIN	TYP	MAX	
$V_{OS}$	Input Offset Voltage	(Note 3)	●	30	60	30	180	$\mu\text{V}$	
			●	40	180	40	250	$\mu\text{V}$	
	Average Temperature Coefficient of Input Offset Voltage		●	0.2	0.6	0.2	1.5	$\mu\text{V}/^{\circ}\text{C}$	
$I_{OS}$	Input Offset Current	(Note 3)	●	30	250	30	250	$\mu\text{A}$	
			●	70	350	70	350	$\mu\text{A}$	
	Average Temperature Coefficient of Input Offset Current		●	0.3	2.5	0.3	2.5	$\mu\text{A}/^{\circ}\text{C}$	
$I_B$	Input Bias Current	(Note 3)	●	$\pm 80$	$\pm 600$	$\pm 80$	$\pm 600$	$\mu\text{A}$	
			●	$\pm 150$	$\pm 800$	$\pm 150$	$\pm 800$	$\mu\text{A}$	
	Average Temperature Coefficient of Input Bias Current		●	0.6	6.0	0.6	6.0	$\mu\text{A}/^{\circ}\text{C}$	
$A_{VOL}$	Large-Signal Voltage Gain	$V_{OUT} = \pm 12\text{V}$ , $R_L \geq 10\text{k}\Omega$	●	200	1000	150	1000	$\text{V}/\text{mV}$	
		$V_{OUT} = \pm 10\text{V}$ , $R_L \geq 2\text{k}\Omega$	●	200	600	100	600	$\text{V}/\text{mV}$	
CMRR	Common Mode Rejection Ratio	$V_{CM} = \pm 13.5\text{V}$	●	110	128	108	128	dB	
PSRR	Power Supply Rejection Ratio	$V_S = \pm 1.5\text{V}$ to $\pm 20\text{V}$	●	110	126	108	126	dB	
	Input Voltage Range		●	$\pm 13.5$		$\pm 13.5$		V	
$V_{OUT}$	Output Voltage Swing	$R_L = 10\text{k}\Omega$	●	$\pm 13$	$\pm 14$	$\pm 13$	$\pm 14$	V	
$I_S$	Supply Current		●	400	650	400	800	$\mu\text{A}$	

# LT1012A/LT1012

## ELECTRICAL CHARACTERISTICS

The ● denotes the specifications which apply over the full operating temperature range of  $0^{\circ}\text{C} \leq T_A \leq 70^{\circ}\text{C}$ .  $V_S = \pm 15\text{V}$ ,  $V_{CM} = 0\text{V}$ , unless otherwise noted.

SYMBOL	PARAMETER	CONDITIONS	LT1012AC			LT1012C			UNITS
			MIN	TYP	MAX	MIN	TYP	MAX	
$V_{OS}$	Input Offset Voltage	(Note 3)	●	20	60	20	100	$\mu\text{V}$	
			●	30	160	30	200	$\mu\text{V}$	
	Average Temperature Coefficient of Input Offset Voltage		●	0.2	0.6	0.2	1.0	$\mu\text{V}/^{\circ}\text{C}$	
$I_{OS}$	Input Offset Current	(Note 3)	●	25	230	35	230	$\mu\text{A}$	
			●	40	300	45	300	$\mu\text{A}$	
	Average Temperature Coefficient of Input Offset Current		●	0.3	2.5	0.3	2.5	$\mu\text{A}/^{\circ}\text{C}$	
$I_B$	Input Bias Current	(Note 3)	●	$\pm 35$	$\pm 230$	$\pm 35$	$\pm 230$	$\mu\text{A}$	
			●	$\pm 50$	$\pm 300$	$\pm 50$	$\pm 300$	$\mu\text{A}$	
	Average Temperature Coefficient of Input Bias Current		●	0.3	2.5	0.3	2.5	$\mu\text{A}/^{\circ}\text{C}$	
$A_{VOL}$	Large-Signal Voltage Gain	$V_{OUT} = \pm 12\text{V}$ , $R_L \geq 10\text{k}\Omega$	●	200	1500	150	1500	$\text{V}/\text{mV}$	
		$V_{OUT} = \pm 10\text{V}$ , $R_L \geq 2\text{k}\Omega$	●	200	1000	150	800	$\text{V}/\text{mV}$	
CMRR	Common Mode Rejection Ratio	$V_{CM} = 13.5\text{V}$	●	110	130	108	130	dB	
PSRR	Power Supply Rejection Ratio	$V_S = \pm 1.3\text{V}$ to $\pm 20\text{V}$	●	110	128	108	128	dB	
	Input Voltage Range		●	$\pm 13.5$		$\pm 13.5$		V	
$V_{OUT}$	Output Voltage Swing	$R_L = 10\text{k}\Omega$	●	$\pm 13$	$\pm 14$	$\pm 13$	$\pm 14$	V	
$I_S$	Supply Current		●	400	600	400	800	$\mu\text{A}$	

**ELECTRICAL CHARACTERISTICS** The ● denotes the specifications which apply over the full operating temperature range of  $0^{\circ}\text{C} \leq T_A \leq 70^{\circ}\text{C}$ .  $V_S = \pm 15\text{V}$ ,  $V_{CM} = 0\text{V}$ , unless otherwise noted.

SYMBOL	PARAMETER	CONDITIONS	LT1012D			LT1012S8			UNITS
			MIN	TYP	MAX	MIN	TYP	MAX	
$V_{OS}$	Input Offset Voltage	(Note 3)	●	25	140	●	30	200	$\mu\text{V}$
	Average Temperature Coefficient of Input Offset Voltage		●	0.3	1.7	●	0.3	1.8	$\mu\text{V}/^{\circ}\text{C}$
$I_{OS}$	Input Offset Current	(Note 3)	●	35	380	●	60	380	$\text{pA}$
	Average Temperature Coefficient of Input Offset Current		●	0.35	4.0	●	0.4	4.0	$\text{pA}/^{\circ}\text{C}$
$I_B$	Input Bias Current	(Note 3)	●	$\pm 50$	$\pm 420$	●	$\pm 100$	$\pm 420$	$\text{pA}$
	Average Temperature Coefficient of Input Bias Current		●	0.4	5.0	●	0.5	5.0	$\text{pA}/^{\circ}\text{C}$
$A_{VOL}$	Large-Signal Voltage Gain	$V_{OUT} = \pm 12\text{V}$ , $R_L \geq 10\text{k}\Omega$	●	150	1500	●	150	1500	$\text{V}/\text{mV}$
		$V_{OUT} = \pm 10\text{V}$ , $R_L \geq 2\text{k}\Omega$	●	150	800	●	100	800	$\text{V}/\text{mV}$
CMRR	Common Mode Rejection Ratio	$V_{CM} = \pm 13.5\text{V}$	●	108	130	●	108	130	dB
PSRR	Power Supply Rejection Ratio	$V_S = \pm 1.3\text{V}$ to $\pm 20\text{V}$	●	108	128	●	108	128	dB
	Input Voltage Range		●	$\pm 13.5$		●	$\pm 13.5$		V
$V_{OUT}$	Output Voltage Swing	$R_L = 10\text{k}\Omega$	●	$\pm 13$	$\pm 14$	●	$\pm 13$	$\pm 14$	V
$I_S$	Supply Current		●	400	800	●	400	800	$\mu\text{A}$

**Note 1:** Absolute Maximum Ratings are those values beyond which the life of a device may be impaired.

**Note 2:** Differential input voltages greater than 1V will cause excessive current to flow through the input protection diodes unless limiting resistance is used.

**Note 3:** These specifications apply for  $V_{MIN} \leq V_S \leq \pm 20\text{V}$  and  $-13.5\text{V} \leq V_{CM} \leq 13.5\text{V}$  (for  $V_S = \pm 15\text{V}$ ).  $V_{MIN} = \pm 1.2\text{V}$  at  $25^{\circ}\text{C}$ ,  $\pm 1.3\text{V}$  from  $0^{\circ}\text{C}$  to  $70^{\circ}\text{C}$ ,  $\pm 1.5\text{V}$  from  $-55^{\circ}\text{C}$  to  $125^{\circ}\text{C}$ .

**Note 4:** 10Hz noise voltage density is sample tested on every lot. Devices 100% tested at 10Hz are available on request.

**Note 5:** This parameter is tested on a sample basis only.

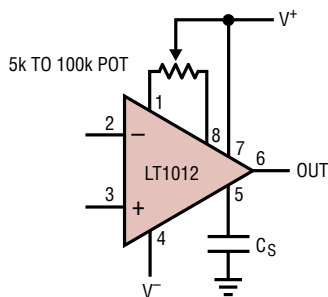

LT1012A • EC01

**Optional Offset Nulling and Overcompensation Circuits**

Input offset voltage can be adjusted over a  $\pm 800\mu\text{V}$  range with a 5k to 100k potentiometer.

The LT1012 is internally compensated for unity gain stability. The overcompensation capacitor,  $C_S$ , can be used to improve capacitive load handling capability, to narrow noise bandwidth, or to stabilize circuits with gain in the feedback loop.

## TYPICAL PERFORMANCE CHARACTERISTICS

**Offset Voltage vs Source Resistance (Balanced or Unbalanced)**

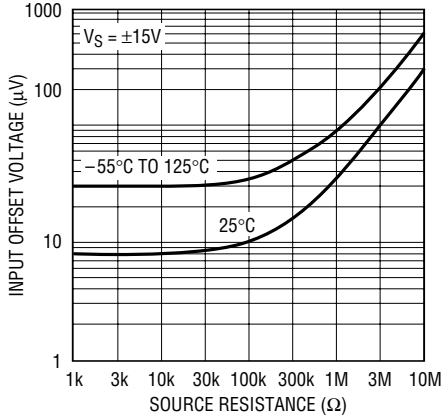

LT1012A • TPC01

**Typical Distribution of Input Bias Current**

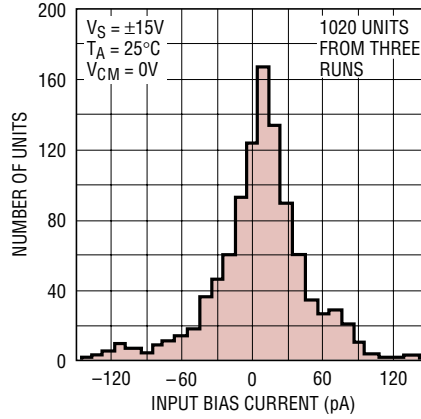

LT1012A • TPC02

**Typical Distribution of Input Offset Current**

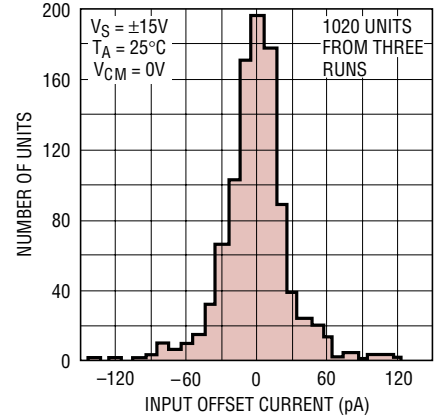

LT1012A • TPC03

**Input Bias Current vs Temperature**

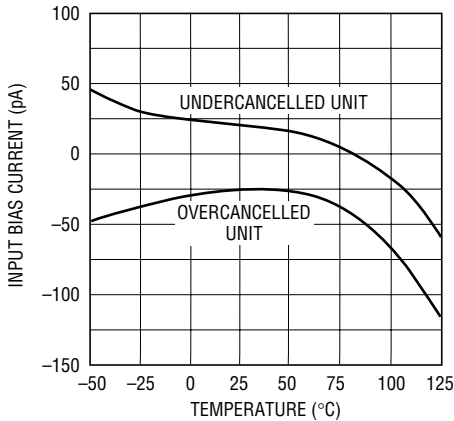

LT1012A • TPC04

**Input Bias Current Over Common Mode Range**

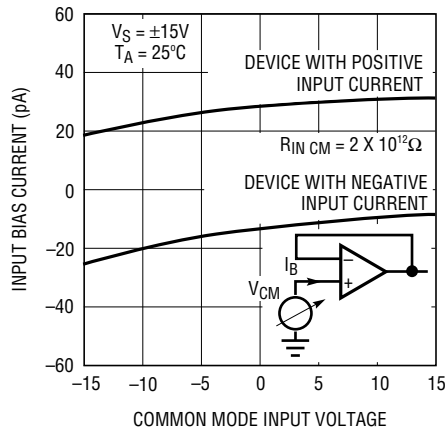

LT1012A • TPC5

**Offset Voltage Drift vs Source Resistance (Balanced or Unbalanced)**

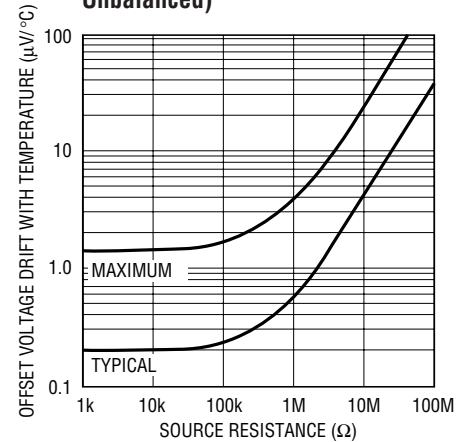

LT1012 • TPC06

**Warm-Up Drift**

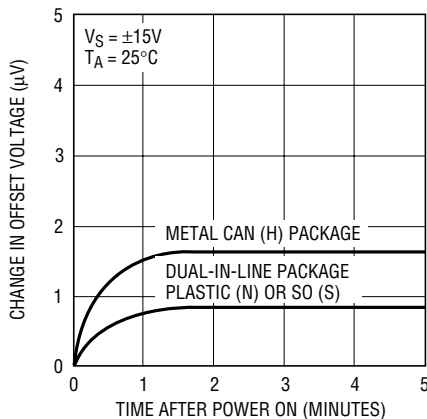

LT1012A • TPC07

**Long Term Stability of Four Representative Units**

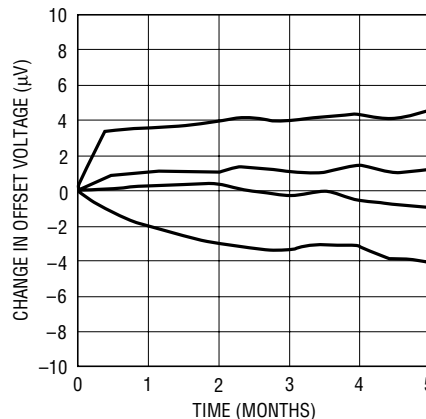

LT1012A • TPC08

**Offset Voltage Drift with Temperature of Four Representative Units**

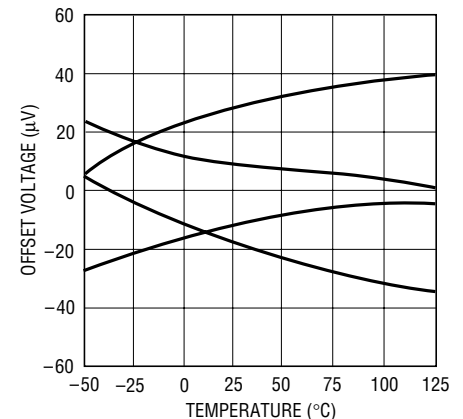

LT1012A • TPC09

# TYPICAL PERFORMANCE CHARACTERISTICS

0.1Hz to 10Hz Noise

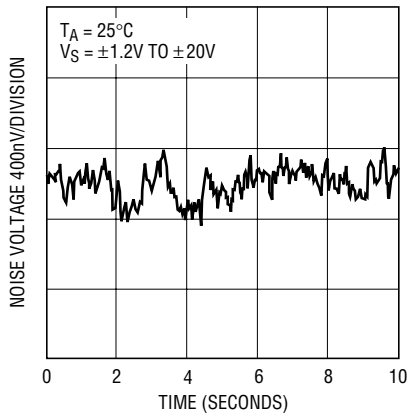

LT1012A • TPC10

Noise Spectrum

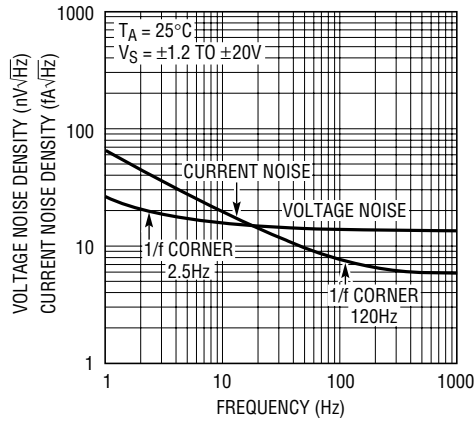

LT1012A • TPC11

Total Noise vs Source Resistance

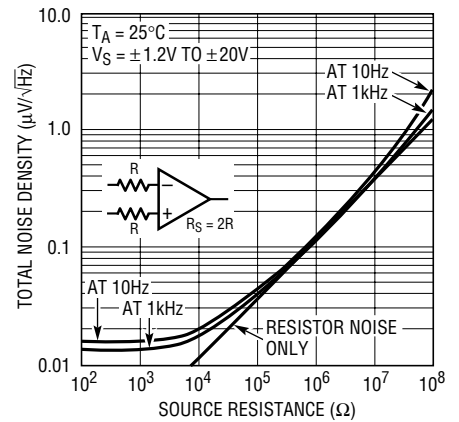

LT1012A • TPC12

Supply Current vs Supply Voltage

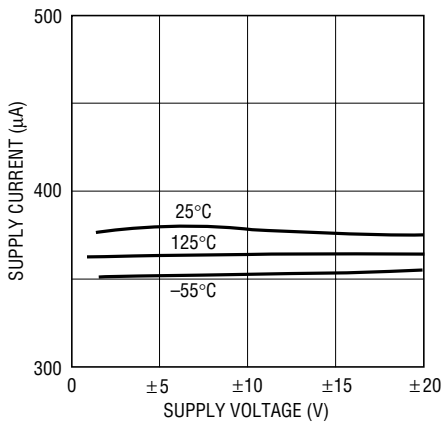

LT1012A • TPC13

Common Mode Rejection vs Frequency

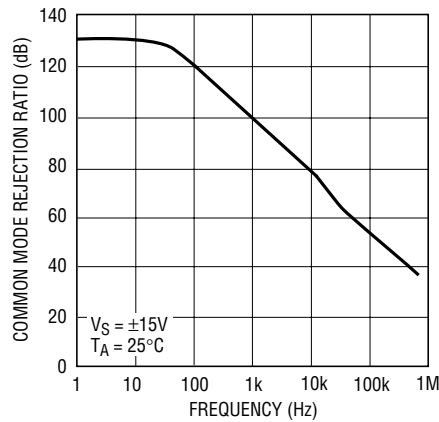

LT1012A • TPC14

Power Supply Rejection vs Frequency

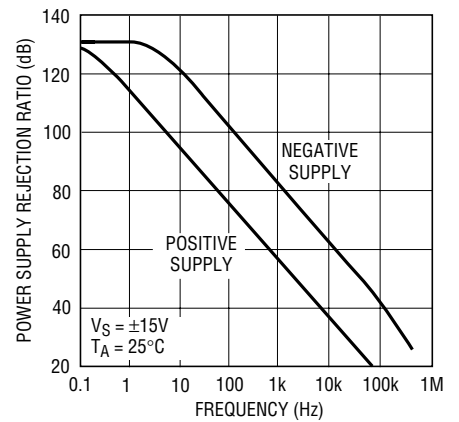

LT1012A • TPC15

Voltage Gain vs Frequency

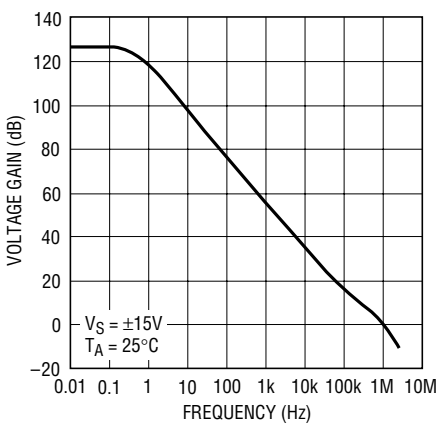

LT1012A • TPC16

Gain, Phase Shift vs Frequency

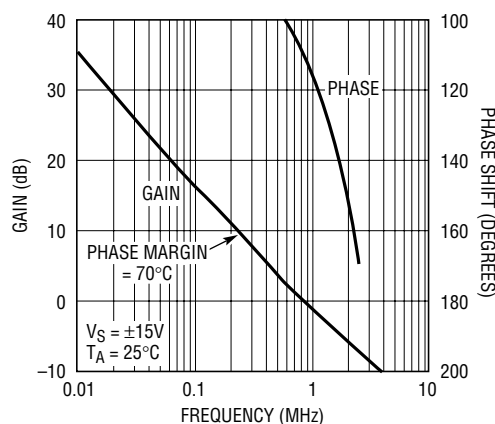

LT1012A • TPC17

Voltage Gain vs Load Resistance

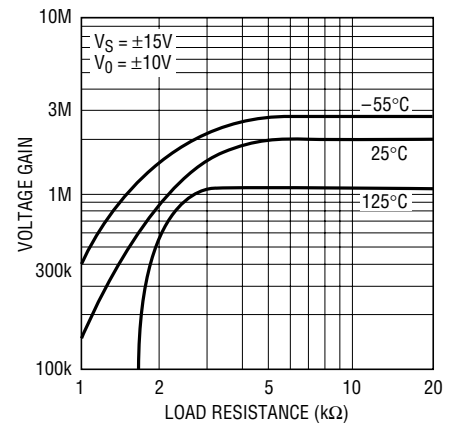

LT1012A • TPC18

## TYPICAL PERFORMANCE CHARACTERISTICS

### Small-Signal Transient Response

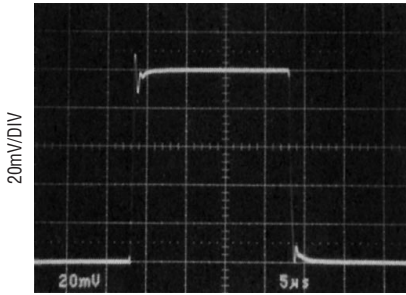

$A_V = +1$   
 $C_{LOAD} = 100pF$

### Small-Signal Transient Response

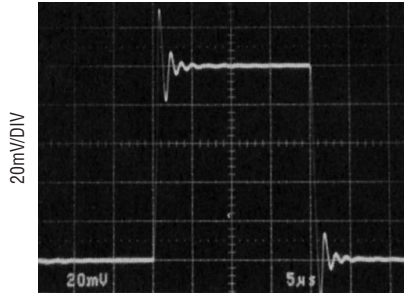

$A_V = +1$   
 $C_{LOAD} = 1000pF$

### Large-Signal Transient Response

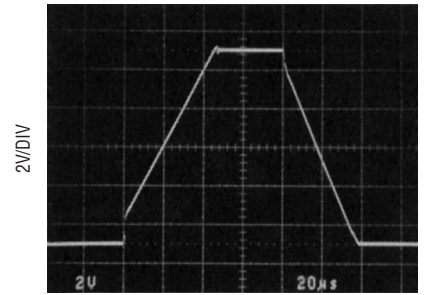

$A_V = +1$   
20µs/DIV

### Output Short-Circuit Current vs Time

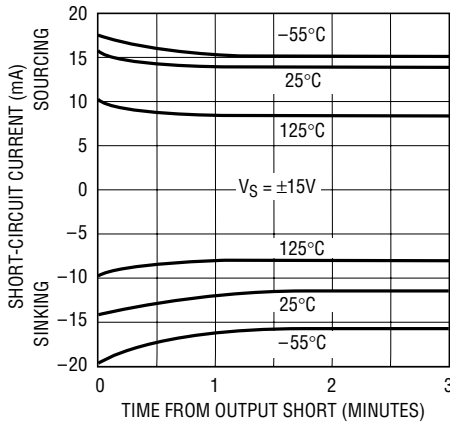

LT1012A • TPC19

### Slew Rate, Gain Bandwidth Product vs Overcompensation Capacitor

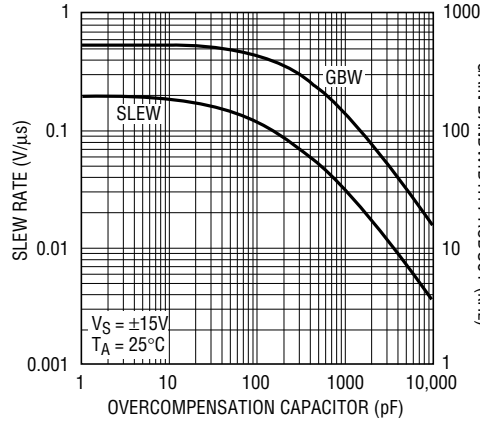

LT1012A • TPC20

### Closed-Loop Output Impedance

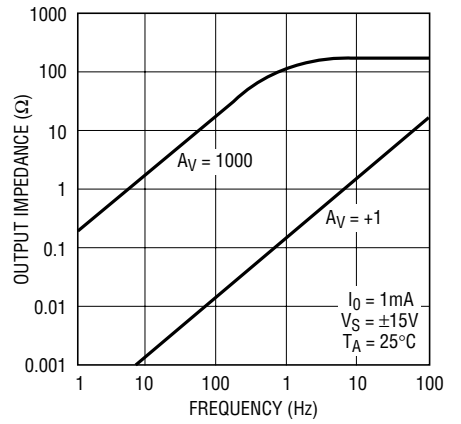

LT1012A • TPC21

### Common Mode Range and Voltage Swing at Minimum Supply Voltage

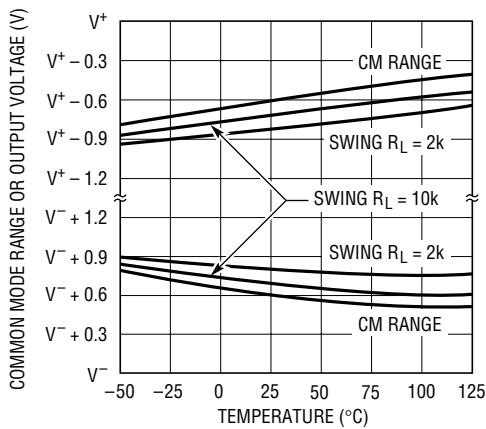

LT1012A • TPC22

### Minimum Supply Voltage, Voltage Gain at VMIN

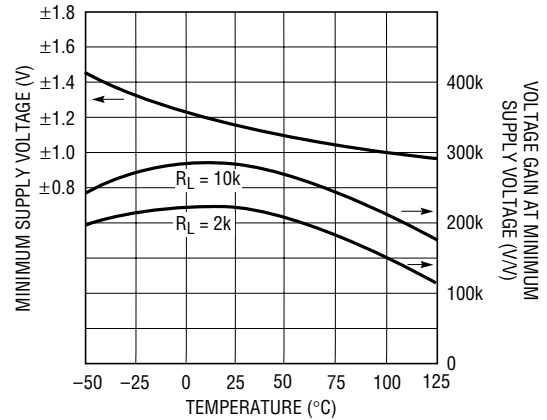

LT1012A • TPC23

## APPLICATIONS INFORMATION

The LT1012 may be inserted directly into OP-07, LM11, 108A or 101A sockets with or without removal of external frequency compensation or nulling components. The LT1012 can also be used in 741, LF411, LF156 or OP-15 applications provided that the nulling circuitry is removed.

Although the OP-97 is a copy of the LT1012, the LT1012 directly replaces and upgrades OP-97 applications. The LT1012C and D have lower offset voltage and drift than the OP-97F. The LT1012A has lower supply current than the OP-97A/E. In addition, all LT1012 grades guarantee operation at  $\pm 1.2V$  supplies.

### Achieving Picoampere/Microvolt Performance

In order to realize the picoampere/microvolt level accuracy of the LT1012, proper care must be exercised. For example, leakage currents in circuitry external to the op amp can significantly degrade performance. High quality insulation should be used (e.g. Teflon, Kel-F); cleaning of all insulating surfaces to remove fluxes and other residues will probably be required. Surface coating may be necessary to provide a moisture barrier in high humidity environments.

Board leakage can be minimized by encircling the input circuitry with a guard ring operated at a potential close to that of the inputs: in inverting configurations the guard ring should be tied to ground, in non-inverting connections to the inverting input at Pin 2. Guarding both sides of the printed circuit board is required. Bulk leakage reduction depends on the guard ring width. Nanoampere level leakage into the offset trim terminals can affect offset voltage and drift with temperature.

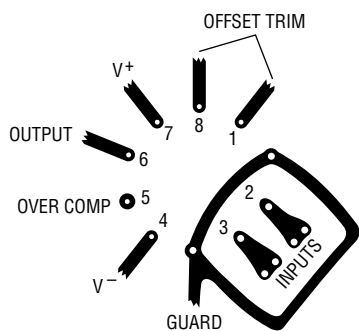

LT1012A • A101

Microvolt level error voltages can also be generated in the external circuitry. Thermocouple effects caused by temperature gradients across dissimilar metals at the contacts to the input terminals can exceed the inherent drift of the amplifier. Air currents over device leads should be minimized, package leads should be short, and the two input leads should be as close together as possible and maintained at the same temperature.

### Noise Testing

For application information on noise testing and calculations, please see the LT1008 data sheet.

### Frequency Compensation

The LT1012 can be overcompensated to improve capacitive load handling capability or to narrow noise bandwidth. In many applications, the feedback loop around the amplifier has gain (e.g. logarithmic amplifiers); overcompensation can stabilize these circuits with a single capacitor.

The availability of the compensation terminal permits the use of feedforward frequency compensation to enhance slew rate. The voltage follower feedforward scheme bypasses the amplifier's gain stages and slews at nearly  $10V/\mu s$ .

The inputs of the LT1012 are protected with back-to-back diodes. Current limiting resistors are not used, because the leakage of these resistors would prevent the realization of picoampere level bias currents at elevated temperatures. In the voltage follower configuration, when the input is driven by a fast, large signal pulse ( $>1V$ ), the input protection diodes effectively short the output to the input during slewing, and a current, limited only by the output short-circuit protection will flow through the diodes.

The use of a feedback resistor, as shown in the voltage follower feedforward diagram, is recommended because this resistor keeps the current below the short-circuit limit, resulting in faster recovery and settling of the output.

## APPLICATIONS INFORMATION

**Test Circuit for Offset Voltage and its Drift with Temperature**

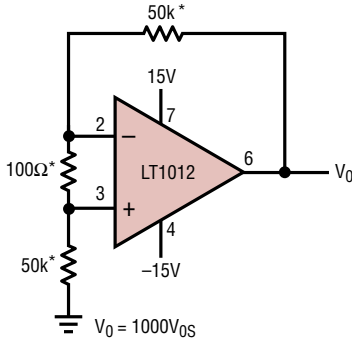

\*RESISTORS MUST HAVE LOW THERMOELECTRIC POTENTIAL

LT1012A • AI02

**Follower Feedforward Compensation**

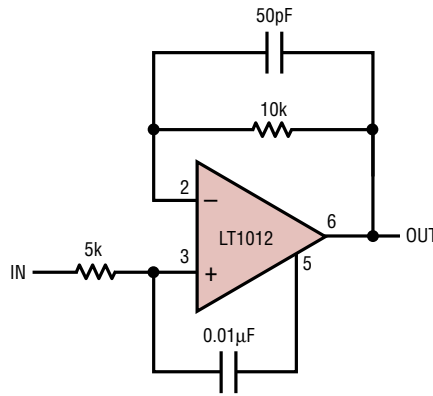

LT1012A • AI03

**Pulse Response of Feedforward Compensation**

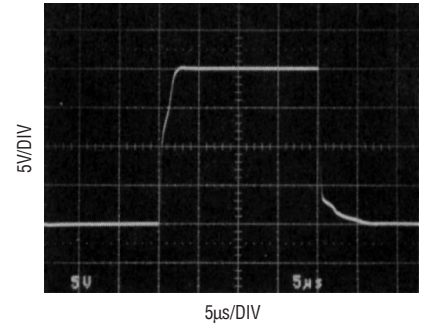

## TYPICAL APPLICATIONS

**Ampmeter with Six Decade Range**

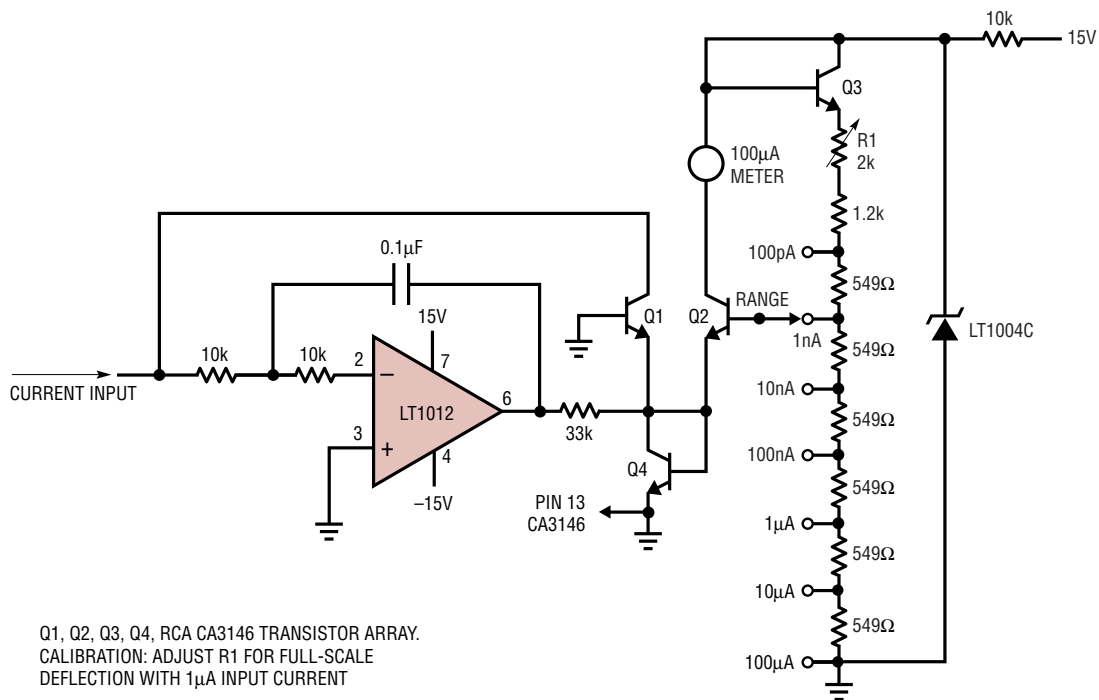

Q1, Q2, Q3, Q4, RCA CA3146 TRANSISTOR ARRAY.  
CALIBRATION: ADJUST R1 FOR FULL-SCALE DEFLECTION WITH 1μA INPUT CURRENT

AMPMETER MEASURES CURRENTS FROM 100pA TO 100μA WITHOUT THE USE OF EXPENSIVE HIGH VALUE RESISTORS. ACCURACY AT 100μA IS LIMITED BY THE OFFSET VOLTAGE BETWEEN Q1 AND Q2 AND, AT 100pA, BY THE INVERTING BIAS CURRENT OF THE LT1012

LT1012A • TA03

TYPICAL APPLICATIONS

Saturated Standard Cell Amplifier

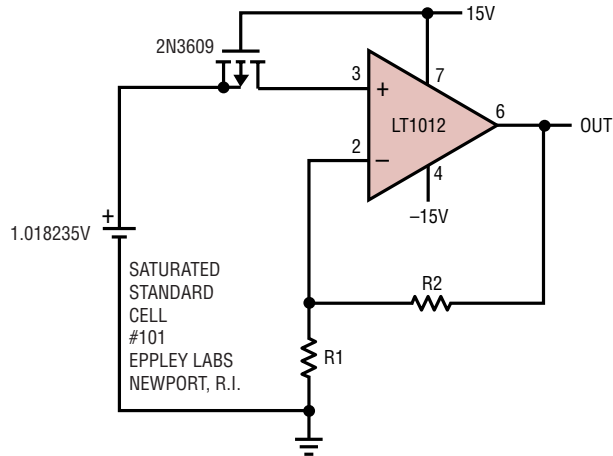

THE TYPICAL 30pA BIAS CURRENT OF THE LT1012 WILL DEGRADE THE STANDARD CELL BY ONLY 1ppm/YEAR. NOISE IS A FRACTION OF A ppm. UNPROTECTED GATE MOSFET ISOLATES STANDARD CELL ON POWER DOWN

LT1012A • TA05

Amplifier for Bridge Transducers

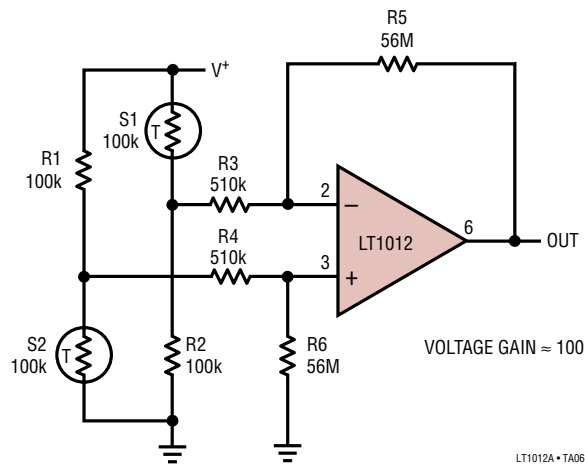

LT1012A • TA06

## TYPICAL APPLICATIONS

### Amplifier for Photodiode Sensor

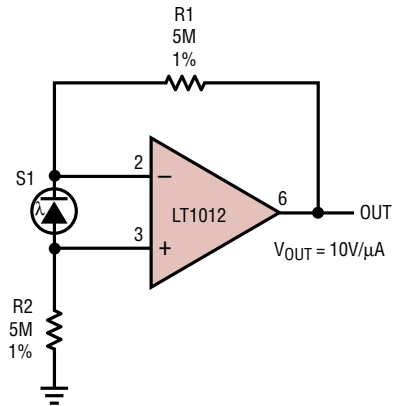

LT1012A • TA07

### Buffered Reference for A-to-D Converters

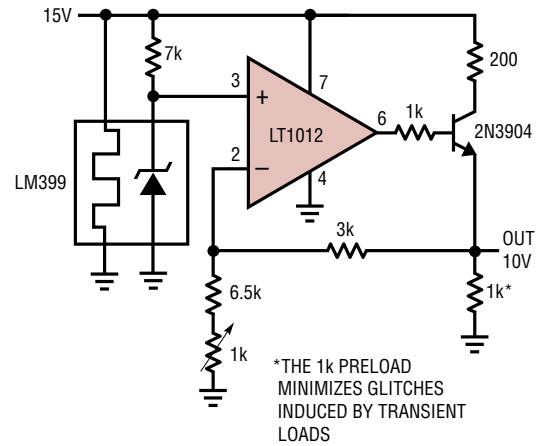

LT1012A • TA08

### Instrumentation Amplifier with ±100V Common Mode Range

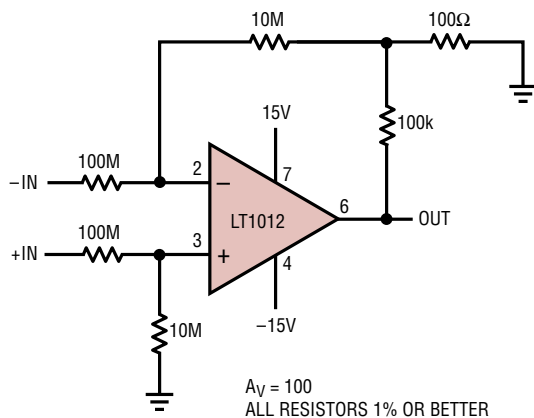

LT1012A • TA09

### Low Power Comparator with <math><10\mu V</math> Hysteresis

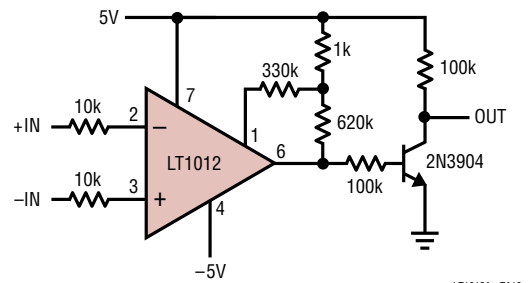

LT1012A • TA10

TYPICAL APPLICATIONS

Air Flow Detector

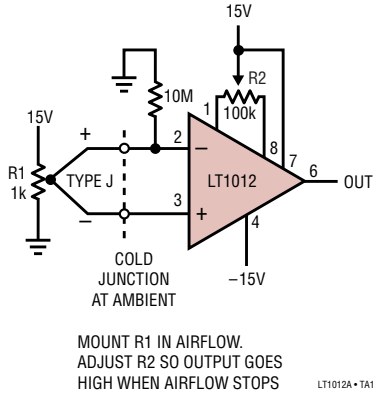

Input Amplifier for 4.5 Digit Voltmeter

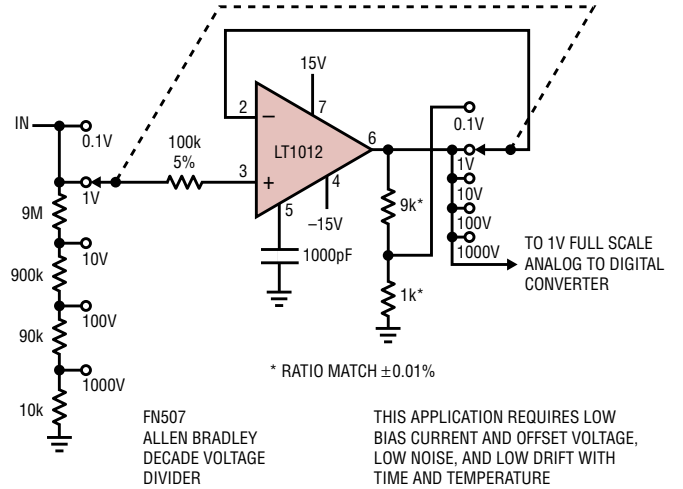

Resistor Multiplier

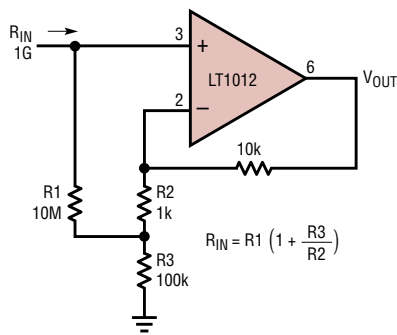

“No Trims” 12-Bit Multiplying DAC Output Amplifier

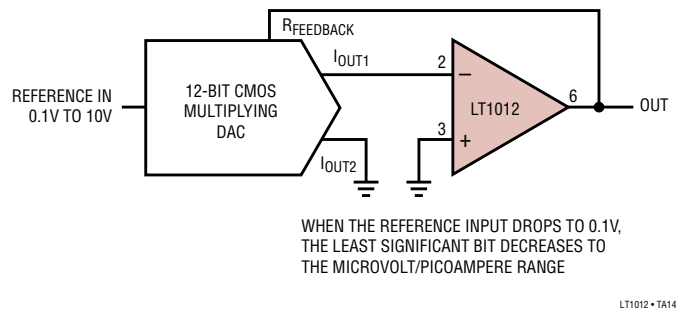

## SCHEMATIC DIAGRAM

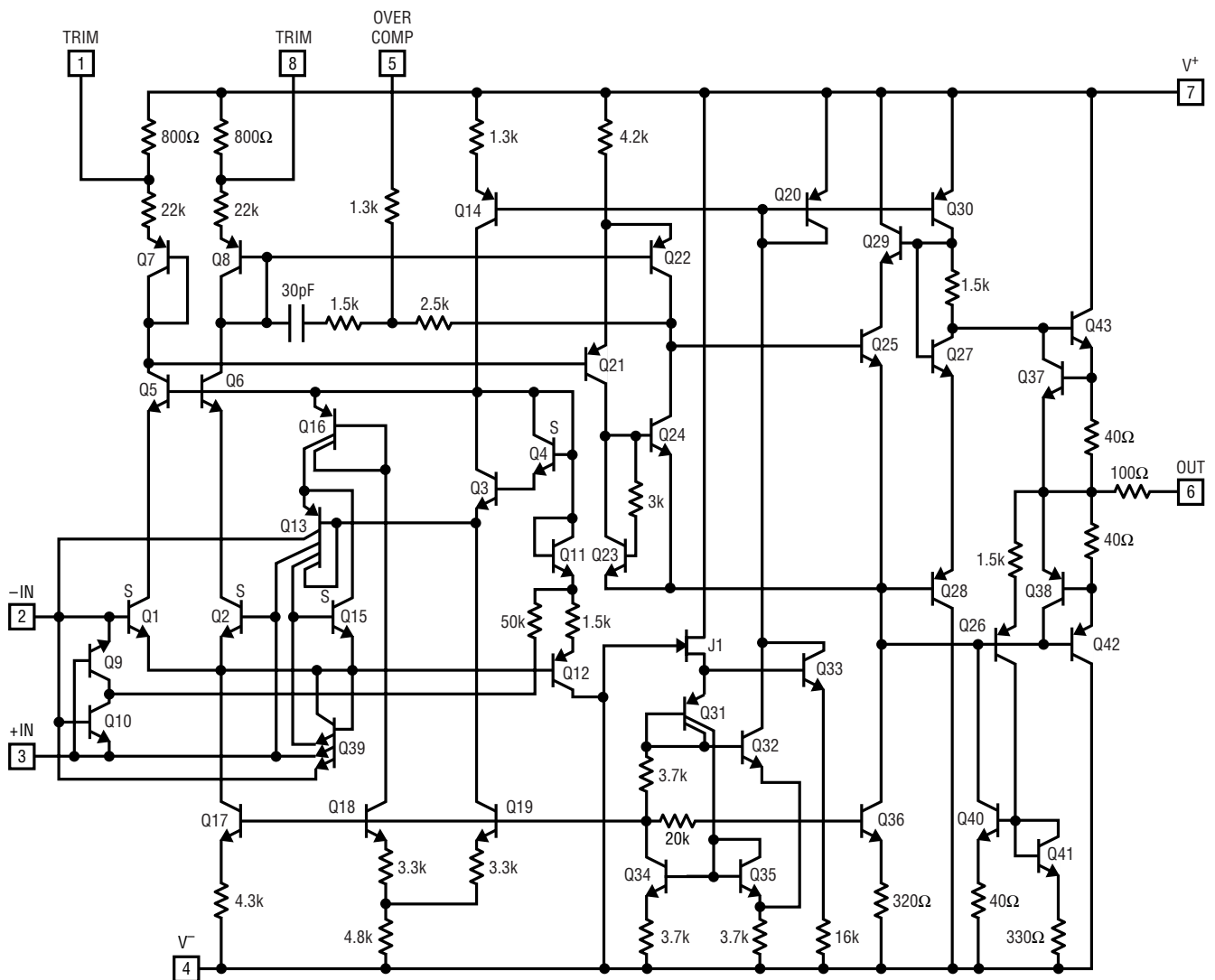

LT1012A • SD01

**PACKAGE DESCRIPTION**

**H Package**  
**8-Lead TO-5 Metal Can (.200 Inch PCD)**  
 (Reference LTC DWG # 05-08-1320)

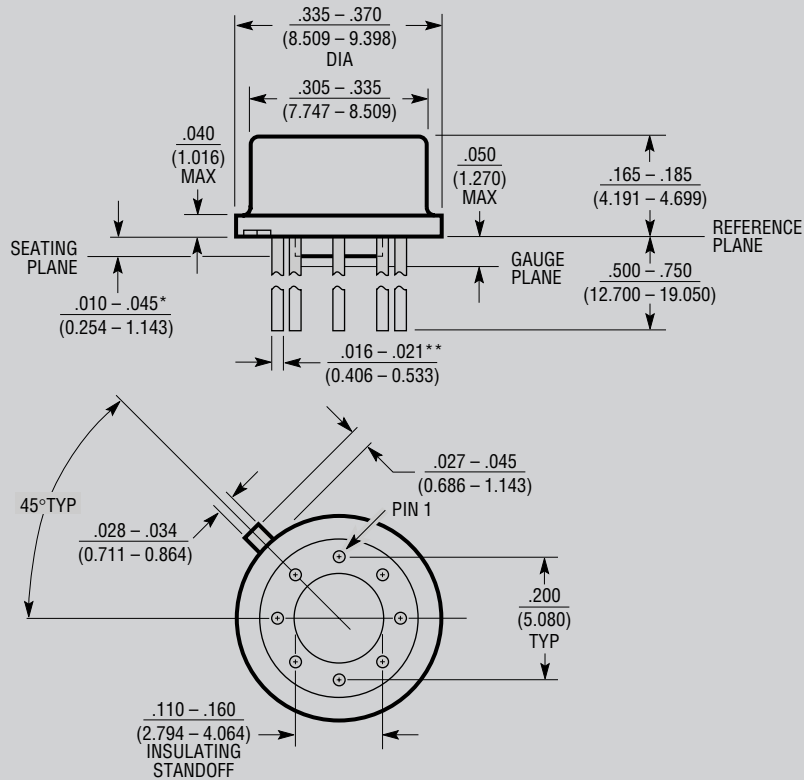

\* LEAD DIAMETER IS UNCONTROLLED BETWEEN THE REFERENCE PLANE AND THE SEATING PLANE

\*\* FOR SOLDER DIP LEAD FINISH, LEAD DIAMETER IS  $\frac{.016 - .024}{(0.406 - 0.610)}$  H8(TO-5) 0.200 PCD 0801

**OBsolete PACKAGE**

**PACKAGE DESCRIPTION**

**N8 Package**  
**8-Lead PDIP (Narrow .300 Inch)**  
 (Reference LTC DWG # 05-08-1510)

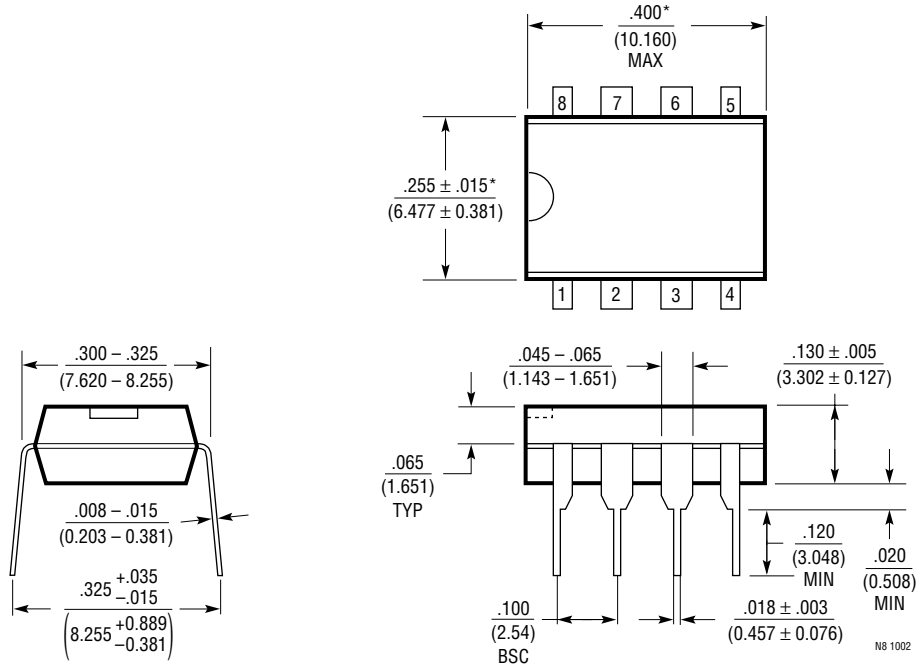

NOTE:  
 1. DIMENSIONS ARE  $\frac{\text{INCHES}}{\text{MILLIMETERS}}$   
 \*THESE DIMENSIONS DO NOT INCLUDE MOLD FLASH OR PROTRUSIONS.  
 MOLD FLASH OR PROTRUSIONS SHALL NOT EXCEED .010 INCH (0.254mm)

N8 1002

**PACKAGE DESCRIPTION**

**S8 Package**  
**8-Lead Plastic Small Outline (Narrow .150 Inch)**  
 (Reference LTC DWG # 05-08-1610)

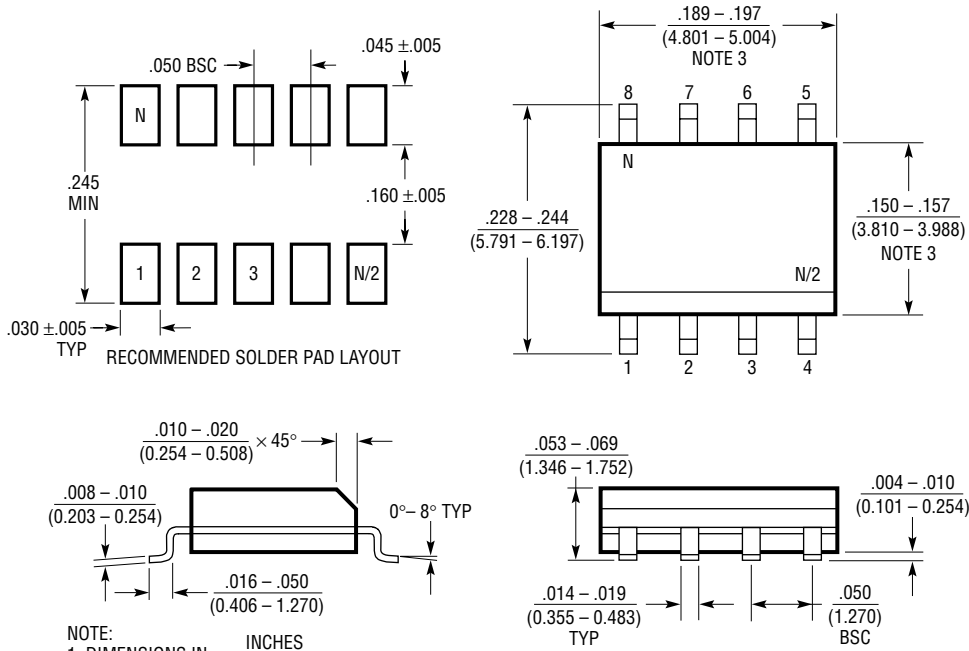

- NOTE:  
 1. DIMENSIONS IN  $\frac{\text{INCHES}}{\text{MILLIMETERS}}$   
 2. DRAWING NOT TO SCALE  
 3. THESE DIMENSIONS DO NOT INCLUDE MOLD FLASH OR PROTRUSIONS.  
 MOLD FLASH OR PROTRUSIONS SHALL NOT EXCEED .006" (0.15mm)

S08 0502

## TYPICAL APPLICATION

### Kelvin-Sensed Platinum Temperature Sensor Amplifier

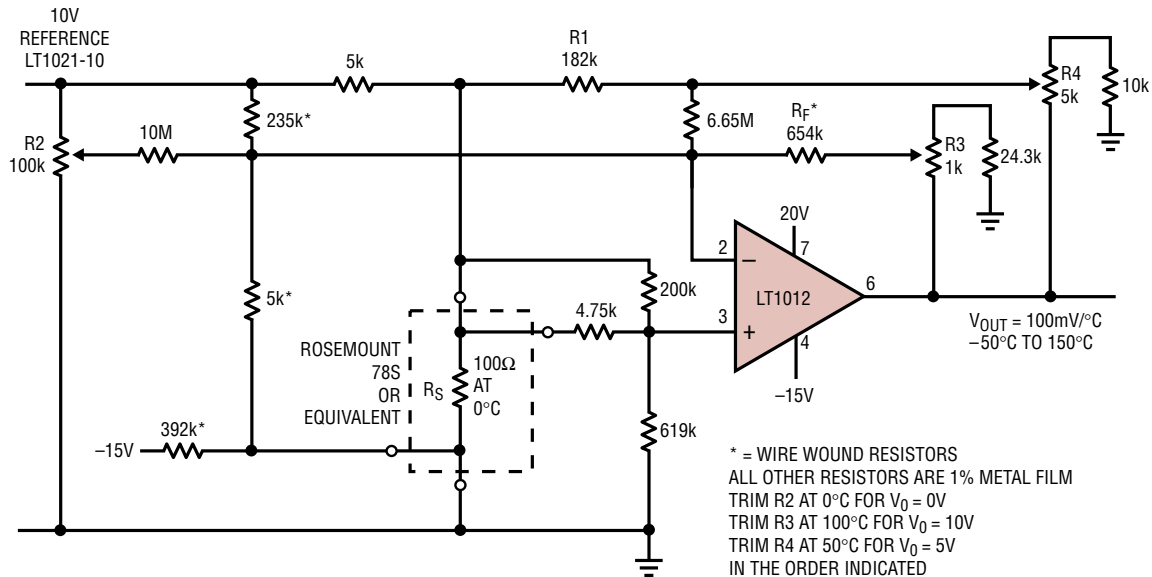

POSITIVE FEEDBACK (R1) LINEARIZES THE  
 INHERENT PARABOLIC NONLINEARITY OF  
 THE PLATINUM SENSOR AND REDUCES  
 ERRORS FROM 1.2°C TO 0.004°C OVER  
 THE -50°C TO 150°C RANGE

LT1012A • TA04

## Looking for pricing, stock, or lifecycle information?

Click below to explore more details on WIN SOURCE:

 [View LT1012CN8#PBF on WIN SOURCE](#)

 [Linear Technology](#) Information

## Optimize Your Supply Chain with WIN SOURCE Solutions

-  Global Sourcing Solution
-  Obsolete Management
-  Cost Control Management
-  Shortage Management
-  Alternative Solution
-  Excess Inventory Management