



P89LPC915/916/917

8-bit microcontrollers with accelerated two-clock 80C51 core
2 kB 3 V flash with 8-bit A/D converter

Rev. 05 — 15 December 2009

Product data sheet

1. General description

The P89LPC915/916/917 are single-chip microcontrollers, available in low-cost packages, based on a high performance processor architecture that executes instructions in two to four clocks, six times the rate of standard 80C51 devices. Many system-level functions have been incorporated into the P89LPC915/916/917 in order to reduce component count, board space, and system cost.

2. Features

2.1 Principal features

- 2 kB byte-erasable flash code memory organized into 256-byte sectors and 16-byte pages. Single-byte erasing allows any byte(s) to be used as non-volatile data storage.
- 256-byte RAM data memory.
- Two 16-bit counter/timers. Timer 0 (and Timer 1 - P89LPC917) may be configured to toggle a port output upon timer overflow or to become a PWM output.
- 23-bit system timer that can also be used as a Real-Time clock.
- 4-input multiplexed 8-bit A/D converter/single DAC output. Two analog comparators with selectable reference.
- Enhanced UART with fractional baud rate generator, break detect, framing error detection, automatic address detection and versatile interrupt capabilities.
- SPI communication port (P89LPC916).
- Internal RC oscillator option allows operation without external oscillator components. The RC oscillator (factory calibrated to $\pm 1\%$) option is selectable and fine tunable.
- 2.4 V to 3.6 V V_{DD} operating range. I/O pins are 5 V tolerant (may be pulled up or driven to 5.5 V).
- Up to 14 I/O pins when using internal oscillator and reset options (P89LPC916, P89LPC917).

2.2 Additional features

- 14-pin (P89LPC915) and 16-pin (P89LPC916, P89LPC917) TSSOP packages.
- A high performance 80C51 CPU provides instruction cycle times of 111 ns to 222 ns for all instructions except multiply and divide when executing at 18 MHz. This is six times the performance of the standard 80C51 running at the same clock frequency. A lower clock frequency for the same performance results in power savings and reduced EMI.
- In-Application Programming (IAP-Lite) and byte erase allows code memory to be used for non-volatile data storage.

- Serial Flash In-Circuit Programming (ICP) allows simple production coding with commercial EPROM programmers. Flash security bits prevent reading of sensitive application programs.
- Watchdog timer with separate on-chip oscillator, requiring no external components. The Watchdog prescaler is selectable from 8 values.
- Low voltage brownout detect allows a graceful system shutdown when power fails. May optionally be configured as an interrupt.
- Idle and two different power-down reduced power modes. Improved wake-up from Power-down mode (a LOW interrupt input starts execution). Typical power-down current is 1 μ A (total power-down with voltage comparators disabled).
- Active-LOW reset. On-chip power-on reset allows operation without external reset components. A reset counter and reset glitch suppression circuitry prevent spurious and incomplete resets. A software reset function is also available.
- Programmable port output configuration options: quasi-bidirectional, open drain, push-pull, input-only.
- Port 'input pattern match' detect. Port 0 may generate an interrupt when the value of the pins match or do not match a programmable pattern.
- LED drive capability (20 mA) on all port pins. A maximum limit is specified for the entire chip.
- Controlled slew rate port outputs to reduce EMI. Outputs have approximately 10 ns minimum ramp times.
- Only power and ground connections are required to operate the P89LPC915/916/917 when internal reset option is selected.
- Four interrupt priority levels.
- Five (P89LPC916), six (P89LPC915), or seven (P89LPC917) keypad interrupt inputs.
- Second data pointer.
- Schmitt trigger port inputs.
- Emulation support.

3. Product comparison overview

[Table 1](#) highlights the differences between these three devices. For a complete list of device features, please see [Section 2 "Features"](#).

Table 1. Product comparison overview

Type number	Comparator 2 output	SPI	T1 toggle/PWM	CLKOUT	INT1	KBI
P89LPC915	X	-	-	-	X	6
P89LPC916	-	X	-	-	-	5
P89LPC917	X	-	X	X	X	7

4. Ordering information

Table 2. Ordering information

Type number	Package		
	Name	Description	Version
P89LPC915FDH	TSSOP14	plastic thin shrink small outline package; 14 leads; body width 4.4 mm	SOT402-1
P89LPC915FN	DIP14	plastic dual in-line package; 14 leads (300 mil)	SOT27-1
P89LPC915HDH	TSSOP14	plastic thin shrink small outline package; 14 leads; body width 4.4 mm	SOT402-1
P89LPC916FDH	TSSOP16	plastic thin shrink small outline package; 16 leads; body width 4.4 mm	SOT403-1
P89LPC917FDH	TSSOP16	plastic thin shrink small outline package; 16 leads; body width 4.4 mm	SOT403-1

4.1 Ordering options

Table 3. Ordering options^[1]

Type number	Temperature range	Frequency
P89LPC915FDH	-40 °C to +85 °C	0 MHz to 18 MHz
P89LPC915FN		
P89LPC916FDH		
P89LPC917FDH		
P89LPC915HDH	-40 °C to +125 °C	

[1] Please contact your local NXP sales office for availability of extended temperature (-40 °C to +125 °C) versions of the P89LPC916 and P89LPC917 devices.

5. Block diagram

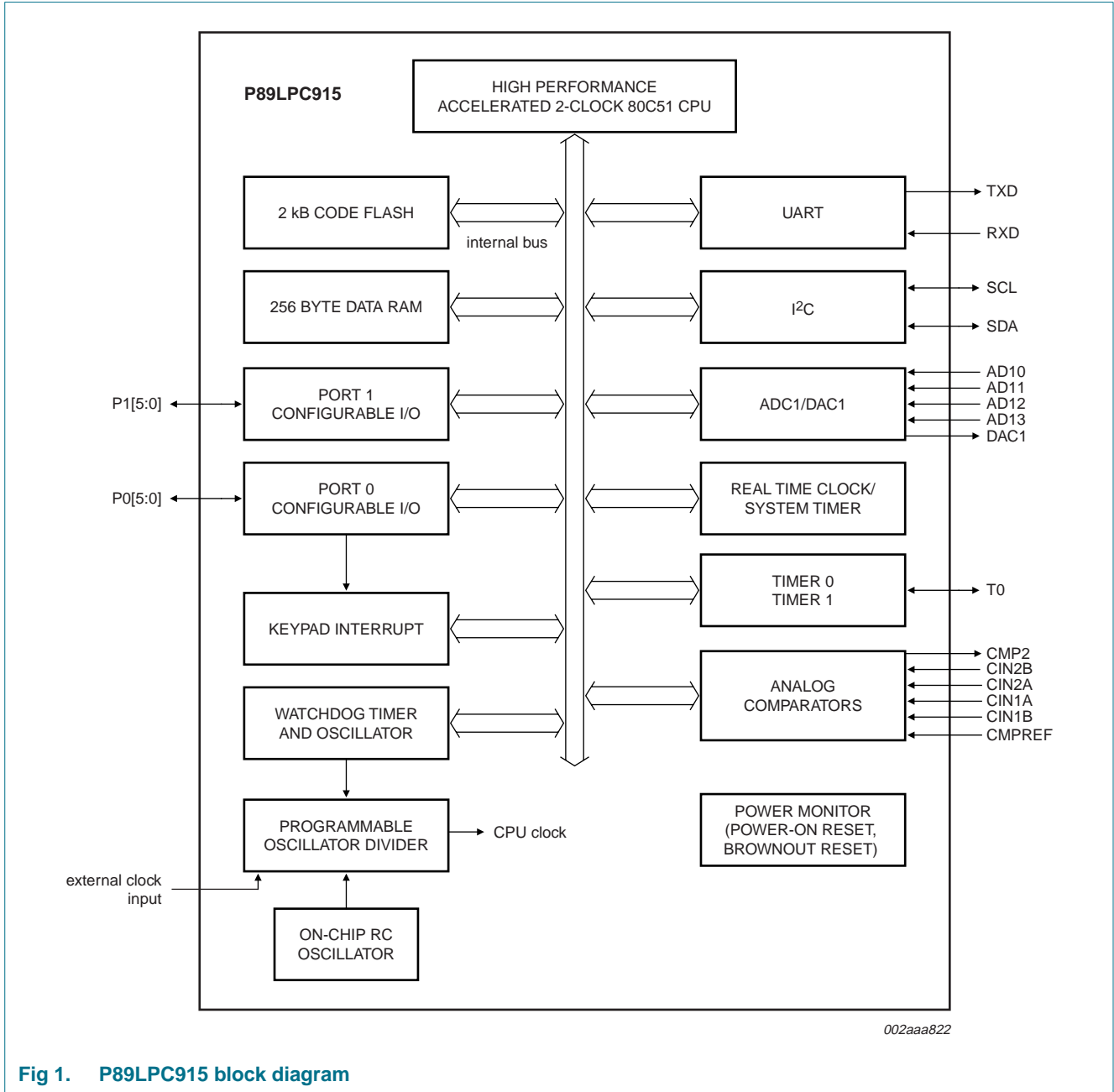
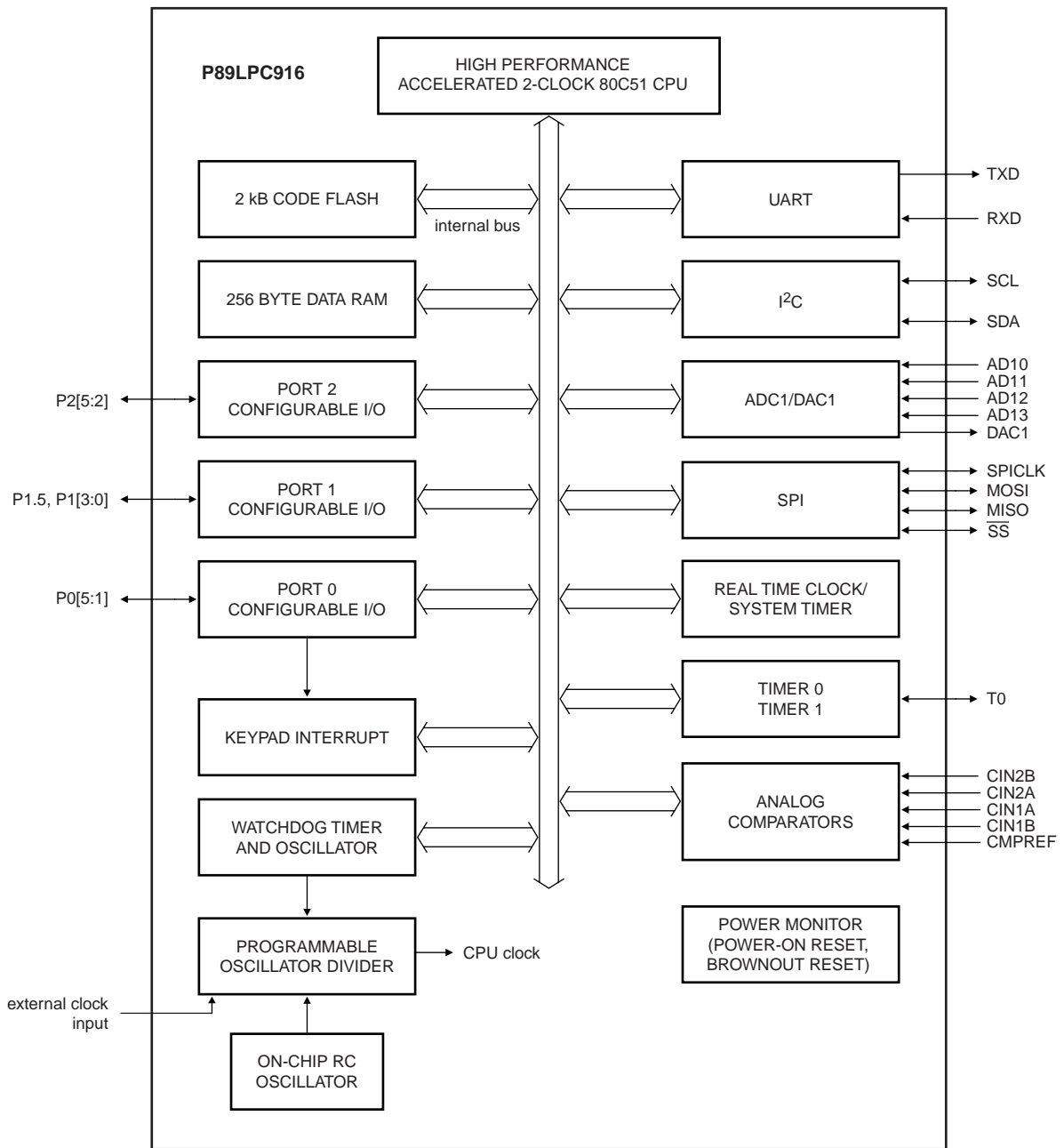

Fig 1. P89LPC915 block diagram



002aaa823

Fig 2. P89LPC916 block diagram

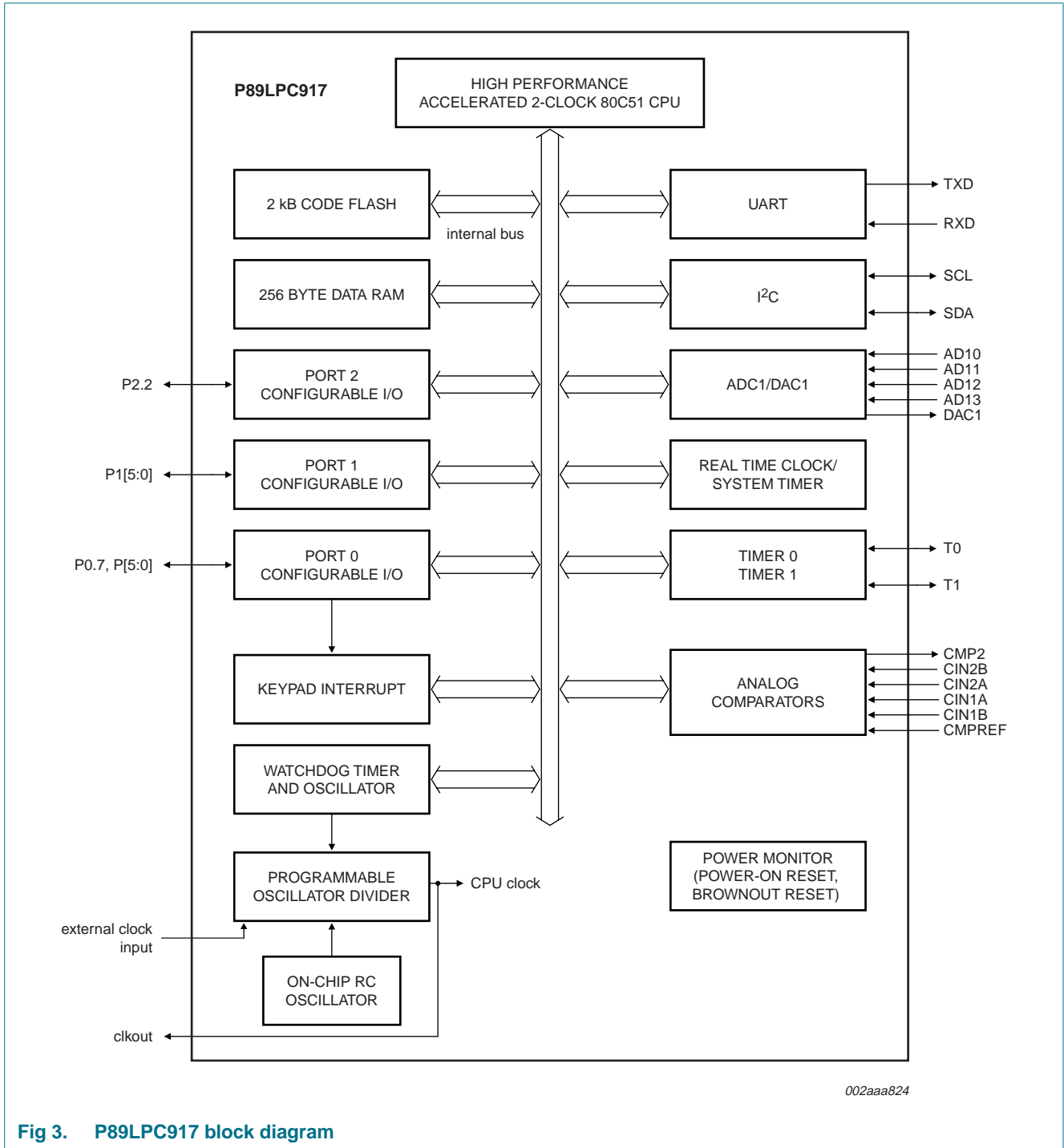

Fig 3. P89LPC917 block diagram

6. Functional diagram

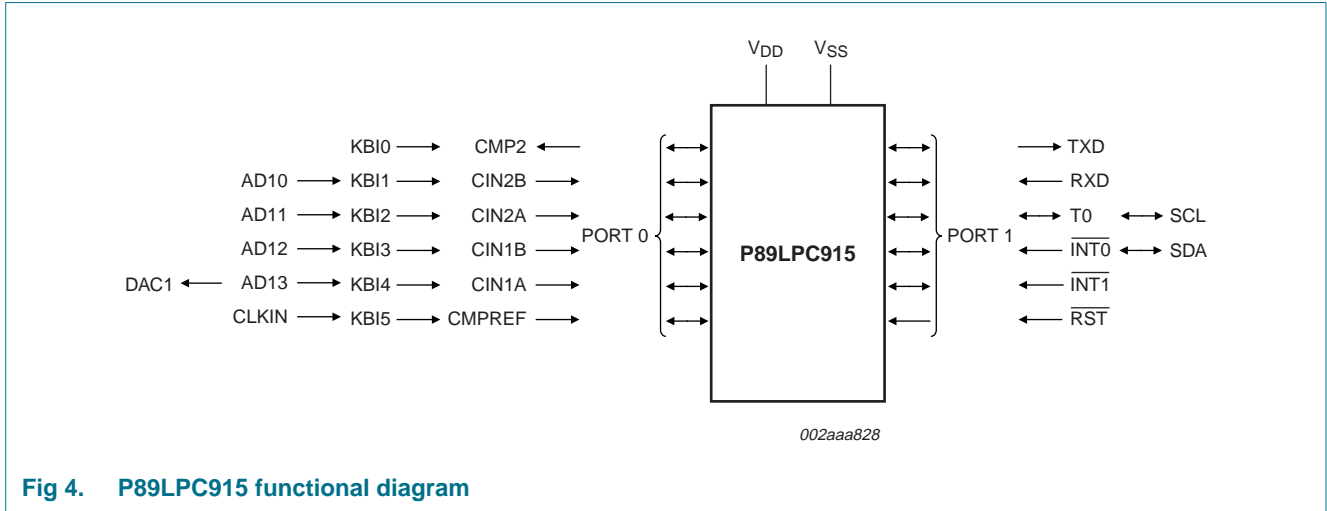

Fig 4. P89LPC915 functional diagram

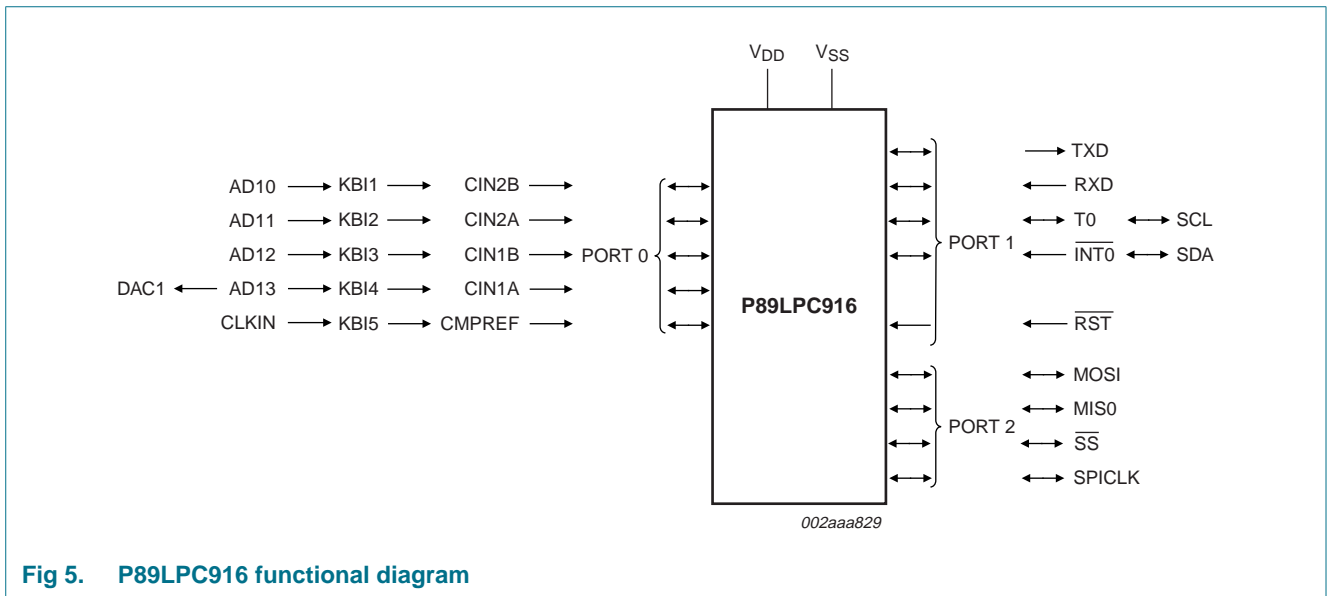

Fig 5. P89LPC916 functional diagram

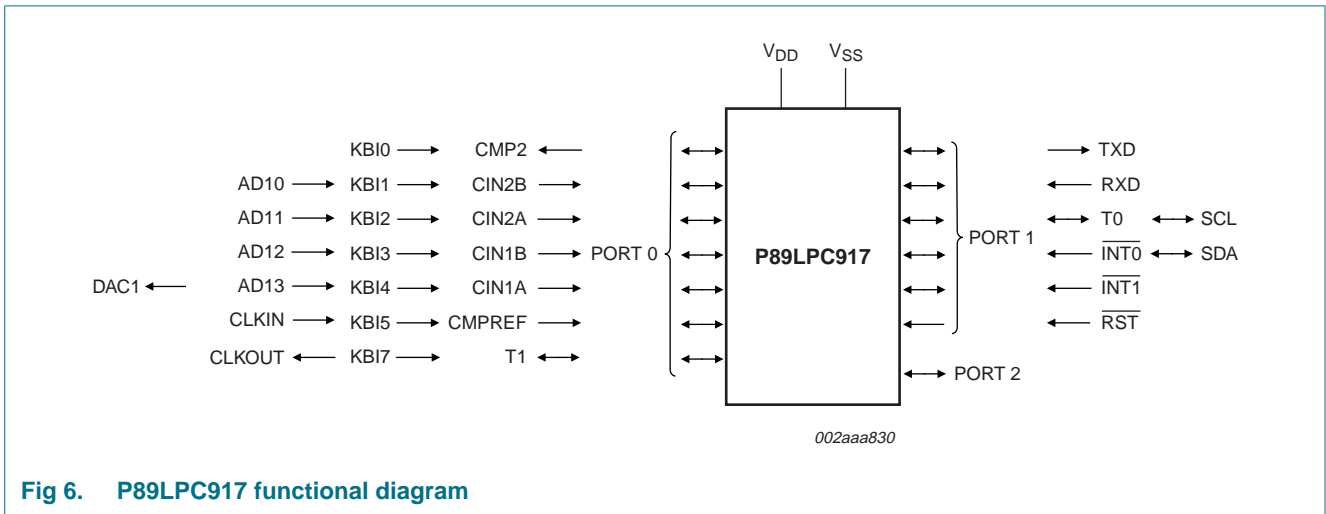
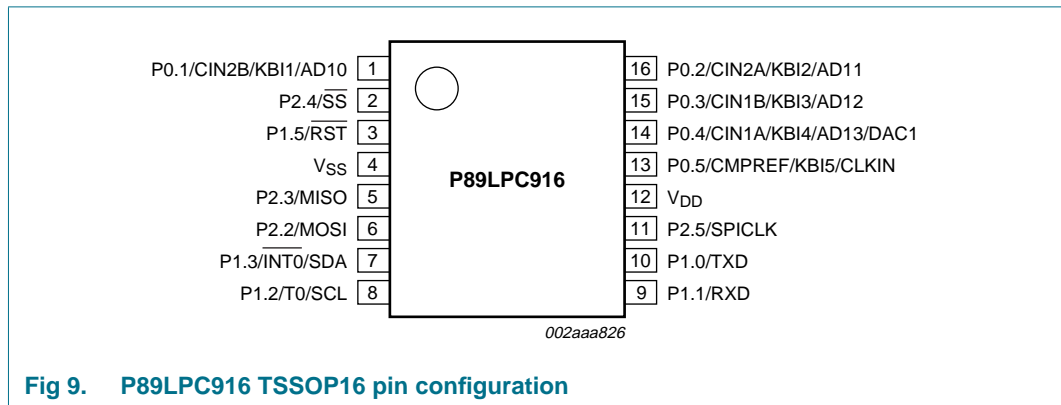
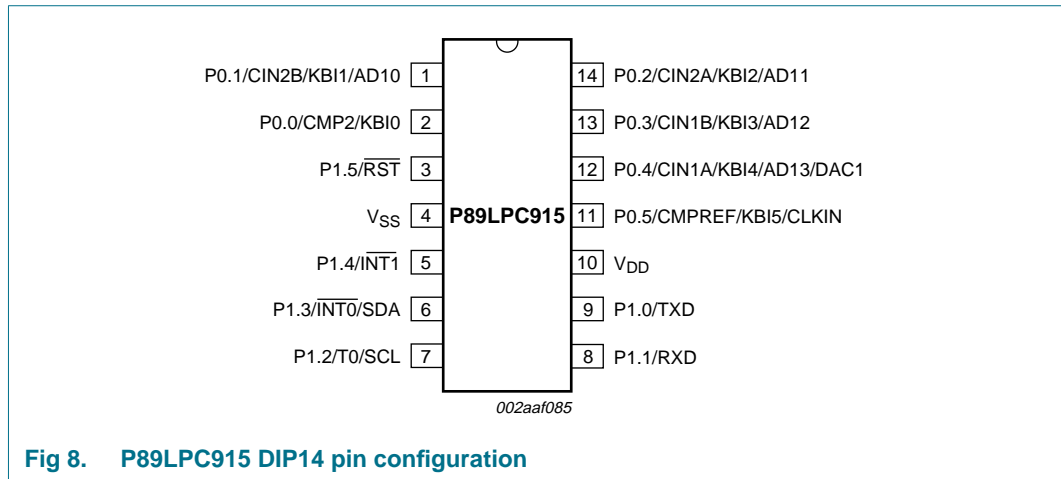
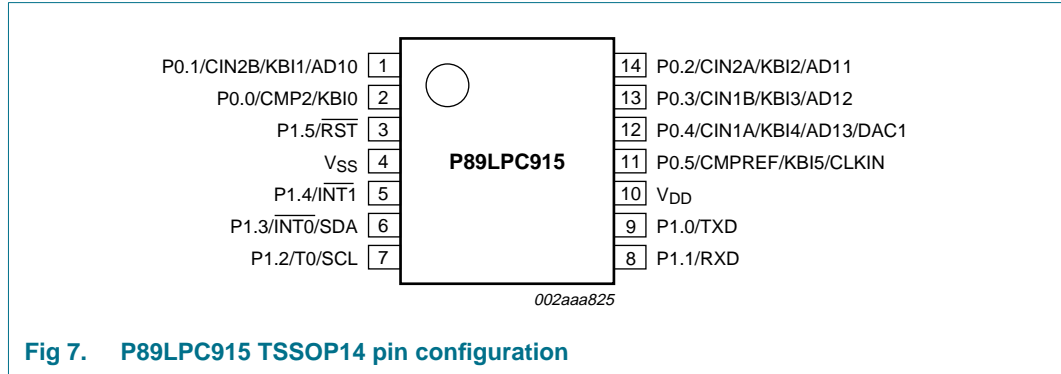
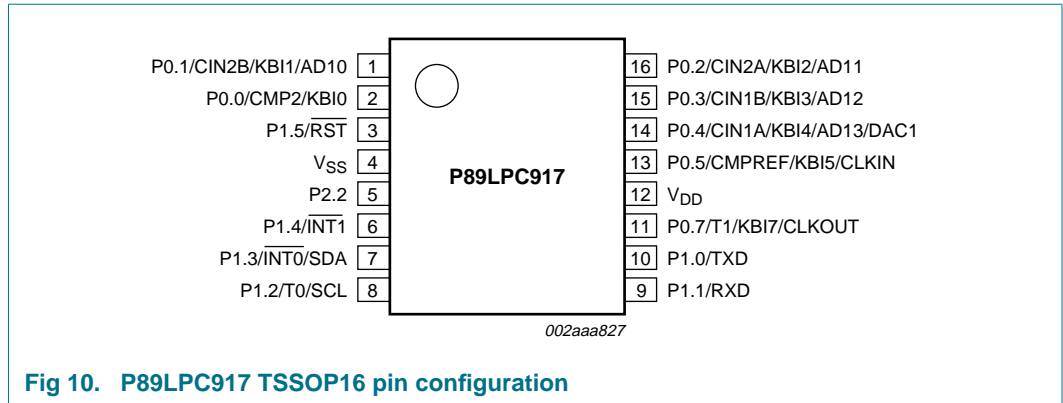

Fig 6. P89LPC917 functional diagram

7. Pinning information

7.1 Pinning





7.2 Pin description

Table 4. P89LPC915 pin description

Symbol	Pin	Type	Description
P0.0 to P0.5		I/O	<p>Port 0: Port 0 is a 6-bit I/O port with a user-configurable output type. During reset Port 0 latches are configured in the input only mode with the internal pull-up disabled. The operation of Port 0 pins as inputs and outputs depends upon the port configuration selected. Each port pin is configured independently. Refer to Section 8.13.1 “Port configurations” and Table 15 “Static characteristics” for details.</p> <p>The Keypad Interrupt feature operates with Port 0 pins.</p> <p>All pins have Schmitt triggered inputs.</p> <p>Port 0 also provides various special functions as described below:</p>
P0.0/CMP2/KBI0	2	I/O O I	<p>P0.0 — Port 0 bit 0.</p> <p>CMP2 — Comparator 2 output.</p> <p>KBI0 — Keyboard input 0.</p>
P0.1/CIN2B/KBI1/AD10	1	I/O I I I	<p>P0.1 — Port 0 bit 1.</p> <p>CIN2B — Comparator 2 positive input B.</p> <p>KBI1 — Keyboard input 1.</p> <p>AD10 — ADC1 channel 0 analog input.</p>
P0.2/CIN2A/KBI2/AD11	14	I/O I I I	<p>P0.2 — Port 0 bit 2.</p> <p>CIN2A — Comparator 2 positive input A.</p> <p>KBI2 — Keyboard input 2.</p> <p>AD11 — ADC1 channel 1 analog input.</p>
P0.3/CIN1B/KBI3/AD12	13	I/O I I I	<p>P0.3 — Port 0 bit 3.</p> <p>CIN1B — Comparator 1 positive input B.</p> <p>KBI3 — Keyboard input 3.</p> <p>AD12 — ADC1 channel 2 analog input.</p>
P0.4/CIN1A/KBI4/AD13/ DAC1	12	I/O I I I I	<p>P0.4 — Port 0 bit 4.</p> <p>CIN1A — Comparator 1 positive input A.</p> <p>KBI4 — Keyboard input 4.</p> <p>AD13 — ADC1 channel 3 analog input.</p> <p>DAC1 — DAC1 analog output.</p>
P0.5/CMPREF/KBI5/CLKIN	11	I/O I I I	<p>P0.5 — Port 0 bit 5.</p> <p>CMPREF — Comparator reference (negative) input.</p> <p>KBI5 — Keyboard input 5.</p> <p>CLKIN — External clock input.</p>
P1.0 to P1.5		I/O, I [1]	<p>Port 1: Port 1 is a 6-bit I/O port with a user-configurable output type, except for three pins as noted below. During reset Port 1 latches are configured in the input only mode with the internal pull-up disabled. The operation of the configurable Port 1 pins as inputs and outputs depends upon the port configuration selected. Each of the configurable port pins are programmed independently. Refer to Section 8.13.1 “Port configurations” and Table 15 “Static characteristics” for details. P1.2 to P1.3 are open drain when used as outputs. P1.5 is input only.</p> <p>All pins have Schmitt triggered inputs.</p> <p>Port 1 also provides various special functions as described below:</p>

Table 4. P89LPC915 pin description ...continued

Symbol	Pin	Type	Description
P1.0/TXD	9	I/O	P1.0 — Port 1 bit 0.
		O	TXD — Transmitter output for serial port.
P1.1/RXD	8	I/O	P1.1 — Port 1 bit 1.
		I	RXD — Receiver input for serial port.
P1.2/T0/SCL	7	I/O	P1.2 — Port 1 bit 2 (open-drain when used as output).
		I/O	T0 — Timer/counter 0 external count input or overflow output (open-drain when used as output).
		I/O	SCL — I ² C serial clock input/output.
P1.3/ $\overline{\text{INT0}}$ /SDA	6	I/O	P1.3 — Port 1 bit 3 (open-drain when used as output).
		I	$\overline{\text{INT0}}$ — External interrupt 0 input.
		I/O	SDA — I ² C serial data input/output.
P1.4/ $\overline{\text{INT1}}$	5	I	P1.4 — Port 1 bit 4.
		I	$\overline{\text{INT1}}$ — External interrupt 1 input.
P1.5/ $\overline{\text{RST}}$	3	I	P1.5 — Port 1 bit 5 (input only).
		I	$\overline{\text{RST}}$ — External Reset input during power-on or if selected via UCFG1. When functioning as a reset input, a LOW on this pin resets the microcontroller, causing I/O ports and peripherals to take on their default states, and the processor begins execution at address 0. Also used during a power-on sequence to force ISP mode. When using an oscillator frequency above 12 MHz, the reset input function of P1.5 must be enabled. An external circuit is required to hold the device in reset at power-up until V_{DD} has reached its specified level. When system power is removed V_{DD} will fall below the minimum specified operating voltage. When using an oscillator frequency above 12 MHz, in some applications, an external brownout detect circuit may be required to hold the device in reset when V_{DD} falls below the minimum specified operating voltage.
V _{SS}	4	I	Ground: 0 V reference.
V _{DD}	10	I	Power supply: This is the power supply voltage for normal operation as well as Idle and Power-down modes.

[1] Input/output for P1.0 to P1.4. Input for P1.5.

Table 5. P89LPC916 pin description

Symbol	Pin	Type	Description
P0.0 to P0.5		I/O	<p>Port 0: Port 0 is an 6-bit I/O port with a user-configurable output type. During reset Port 0 latches are configured in the input only mode with the internal pull-up disabled. The operation of Port 0 pins as inputs and outputs depends upon the port configuration selected. Each port pin is configured independently. Refer to Section 8.13.1 “Port configurations” and Table 15 “Static characteristics” for details.</p> <p>The Keypad Interrupt feature operates with Port 0 pins.</p> <p>All pins have Schmitt triggered inputs.</p> <p>Port 0 also provides various special functions as described below:</p>

Table 5. P89LPC916 pin description ...continued

Symbol	Pin	Type	Description
P0.1/CIN2B/KBI1/AD10	1	I/O	P0.1 — Port 0 bit 1.
		I	CIN2B — Comparator 2 positive input B.
		I	KBI1 — Keyboard input 1.
		I	AD10 — ADC1 channel 0 analog input.
P0.2/CIN2A/KBI2/AD11	16	I/O	P0.2 — Port 0 bit 2.
		I	CIN2A — Comparator 2 positive input A.
		I	KBI2 — Keyboard input 2.
P0.3/CIN1B/KBI3/AD12	15	I/O	P0.3 — Port 0 bit 3.
		I	CIN1B — Comparator 1 positive input B.
		I	KBI3 — Keyboard input 3.
P0.4/CIN1A/KBI4/AD13/DAC1	14	I/O	P0.4 — Port 0 bit 4.
		I	CIN1A — Comparator 1 positive input A.
		I	KBI4 — Keyboard input 4.
		O	DAC1 — DAC1 analog output.
P0.5/CMPREF/KBI5/CLKIN	13	I/O	P0.5 — Port 0 bit 5.
		I	CMPREF — Comparator reference (negative) input.
		I	KBI5 — Keyboard input 5.
P1.0 to P1.5		I/O, I [1]	Port 1: Port 1 is an 6-bit I/O port with a user-configurable output type, except for three pins as noted below. During reset Port 1 latches are configured in the input only mode with the internal pull-up disabled. The operation of the configurable Port 1 pins as inputs and outputs depends upon the port configuration selected. Each of the configurable port pins are programmed independently. Refer to Section 8.13.1 “Port configurations” and Table 15 “Static characteristics” for details. P1.2 to P1.3 are open drain when used as outputs. P1.5 is input only. All pins have Schmitt triggered inputs. Port 1 also provides various special functions as described below:
P1.0/TXD	10	I/O	P1.0 — Port 1 bit 0.
		O	TXD — Transmitter output for serial port.
P1.1/RXD	9	I/O	P1.1 — Port 1 bit 1.
		I	RXD — Receiver input for serial port.
P1.2/T0/SCL	8	I/O	P1.2 — Port 1 bit 2 (open-drain when used as output).
		I/O	T0 — Timer/counter 0 external count input or overflow output (open-drain when used as output).
		I/O	SCL — I ² C serial clock input/output.
P1.3/INT0/SDA	7	I/O	P1.3 — Port 1 bit 3 (open-drain when used as output).
		I	INT0 — External interrupt 0 input.
		I/O	SDA — I ² C serial data input/output.
P1.5/RST	3	I	P1.5 — Port 1 bit 5 (input only).

Table 5. P89LPC916 pin description ...continued

Symbol	Pin	Type	Description
		I	RST — External Reset input during power-on or if selected via UCFG1. When functioning as a reset input, a LOW on this pin resets the microcontroller, causing I/O ports and peripherals to take on their default states, and the processor begins execution at address 0. Also used during a power-on sequence to force ISP mode. When using an oscillator frequency above 12 MHz, the reset input function of P1.5 must be enabled. An external circuit is required to hold the device in reset at power-up until V_{DD} has reached its specified level. When system power is removed V_{DD} will fall below the minimum specified operating voltage. When using an oscillator frequency above 12 MHz, in some applications, an external brownout detect circuit may be required to hold the device in reset when V_{DD} falls below the minimum specified operating voltage.
P2.2 to P2.5			Port 2: Port 2 is a 4-bit I/O port with a user-configurable output type. During reset Port 2 latches are configured in the input only mode with the internal pull-up disabled. The operation of Port 2 pins as inputs and outputs depends upon the port configuration selected. Each port pin is configured independently. Refer to Section 8.13.1 “Port configurations” and Table 15 “Static characteristics” for details. All pins have Schmitt triggered inputs. Port 2 also provides various special functions as described below:
P2.2/MOSI	6	I/O	P2.2 — Port 2 bit 2. I/O MOSI — SPI master out slave in. When configured as master, this pin is output; when configured as slave, this pin is input.
P2.3/MISO	5	I/O	P2.3 — Port 2 bit 3. I/O MISO — When configured as master, this pin is input, when configured as slave, this pin is output.
P2.4/ \overline{SS}	2	I/O	P2.4 — Port 2 bit 4. I/O \overline{SS} — SPI Slave select.
P2.5/SPICLK	11	I/O	P2.5 — Port 2 bit 5. I/O SPICLK — SPI clock. When configured as master, this pin is output; when configured as slave, this pin is input.
V _{SS}	4	I	Ground: 0 V reference.
V _{DD}	12	I	Power supply: This is the power supply voltage for normal operation as well as Idle and Power-down modes.

[1] Input/output for P1.0 to P1.3. Input for P1.5.

Table 6. P89LPC917 pin description

Symbol	Pin	Type	Description
P0.0 to P0.5, P0.7		I/O	<p>Port 0: Port 0 is a 7-bit I/O port with a user-configurable output type. During reset Port 0 latches are configured in the input only mode with the internal pull-up disabled. The operation of Port 0 pins as inputs and outputs depends upon the port configuration selected. Each port pin is configured independently. Refer to Section 8.13.1 “Port configurations” and Table 15 “Static characteristics” for details.</p> <p>The Keypad Interrupt feature operates with Port 0 pins.</p> <p>All pins have Schmitt triggered inputs.</p> <p>Port 0 also provides various special functions as described below:</p>
P0.0/CMP2/KBI0	2	I/O O I	<p>P0.0 — Port 0 bit 0.</p> <p>CMP2 — Comparator 2 output.</p> <p>KBI0 — Keyboard input 0.</p>
P0.1/CIN2B/KBI1/AD10	1	I/O I I I	<p>P0.1 — Port 0 bit 1.</p> <p>CIN2B — Comparator 2 positive input B.</p> <p>KBI1 — Keyboard input 1.</p> <p>AD10 — ADC1 channel 0 analog input.</p>
P0.2/CIN2A/KBI2/AD11	16	I/O I I I	<p>P0.2 — Port 0 bit 2.</p> <p>CIN2A — Comparator 2 positive input A.</p> <p>KBI2 — Keyboard input 2.</p> <p>AD11 — ADC1 channel 1 analog input.</p>
P0.3/CIN1B/KBI3/AD12	15	I/O I I I	<p>P0.3 — Port 0 bit 3.</p> <p>CIN1B — Comparator 1 positive input B.</p> <p>KBI3 — Keyboard input 3.</p> <p>AD12 — ADC1 channel 2 analog input.</p>
P0.4/CIN1A/KBI4/AD13/ DAC1	14	I/O I I I O	<p>P0.4 — Port 0 bit 4.</p> <p>CIN1A — Comparator 1 positive input A.</p> <p>KBI4 — Keyboard input 4.</p> <p>AD13 — ADC1 channel 3 analog input.</p> <p>DAC1 — DAC1 analog output.</p>
P0.5/CMPREF/KBI5	13	I/O I I I	<p>P0.5 — Port 0 bit 5.</p> <p>CMPREF — Comparator reference (negative) input.</p> <p>KBI5 — Keyboard input 5.</p> <p>CLKIN — External clock input.</p>

Table 6. P89LPC917 pin description ...continued

Symbol	Pin	Type	Description
P0.7/T1/KBI7/CLKOUT	11	I/O	P0.7 — Port 0 bit 7.
		I/O	T1 — Timer/counter 1 external count input or overflow output.
		I	KBI7 — Keyboard input 7.
		O	CLKOUT — Clock output.
P1.0 to P1.5		I/O, I [1]	<p>Port 1: Port 1 is a 6-bit I/O port with a user-configurable output type, except for three pins as noted below. During reset Port 1 latches are configured in the input only mode with the internal pull-up disabled. The operation of the configurable Port 1 pins as inputs and outputs depends upon the port configuration selected. Each of the configurable port pins are programmed independently. Refer to Section 8.13.1 "Port configurations" and Table 15 "Static characteristics" for details. P1.2 to P1.3 are open drain when used as outputs. P1.5 is input only.</p> <p>All pins have Schmitt triggered inputs.</p> <p>Port 1 also provides various special functions as described below:</p>
P1.0/TXD	10	I/O	P1.0 — Port 1 bit 0.
		O	TXD — Transmitter output for serial port.
P1.1/RXD	9	I/O	P1.1 — Port 1 bit 1.
		I	RXD — Receiver input for serial port.
P1.2/T0/SCL	8	I/O	P1.2 — Port 1 bit 2 (open-drain when used as output).
		I/O	T0 — Timer/counter 0 external count input or overflow output (open-drain when used as output).
		I/O	SCL — I ² C serial clock input/output.
P1.3/ $\overline{\text{INT0}}$ /SDA	7	I/O	P1.3 — Port 1 bit 3 (open-drain when used as output).
		I	$\overline{\text{INT0}}$ — External interrupt 0 input.
		I/O	SDA — I ² C serial data input/output.
P1.4/ $\overline{\text{INT1}}$	6	I	P1.4 — Port 1 bit 4.
		I	$\overline{\text{INT1}}$ — External interrupt 1 input.
P1.5/ $\overline{\text{RST}}$	3	I	P1.5 — Port 1 bit 5 (input only).
		I	<p>$\overline{\text{RST}}$ — External Reset input during power-on or if selected via UCFG1. When functioning as a reset input, a LOW on this pin resets the microcontroller, causing I/O ports and peripherals to take on their default states, and the processor begins execution at address 0. Also used during a power-on sequence to force ISP mode. When using an oscillator frequency above 12 MHz, the reset input function of P1.5 must be enabled. An external circuit is required to hold the device in reset at power-up until V_{DD} has reached its specified level. When system power is removed V_{DD} will fall below the minimum specified operating voltage. When using an oscillator frequency above 12 MHz, in some applications, an external brownout detect circuit may be required to hold the device in reset when V_{DD} falls below the minimum specified operating voltage.</p>

Table 6. P89LPC917 pin description ...continued

Symbol	Pin	Type	Description
P2.2	5		<p>Port 2: Port 2 is a single bit I/O port with a user-configurable output type. During reset Port 2 latches are configured in the input only mode with the internal pull-up disabled. The operation of this Port 2 pin as an input and output depends upon the port configuration selected. Refer to Section 8.13.1 “Port configurations” and Table 15 “Static characteristics” for details.</p> <p>This pin has a Schmitt triggered input.</p>
V _{SS}	4	I	Ground: 0 V reference.
V _{DD}	12	I	Power supply: This is the power supply voltage for normal operation as well as Idle and Power-down modes.

[1] Input/output for P1.0 to P1.4. Input for P1.5.

8. Functional description

8.1 Special function registers

Remark: SFR accesses are restricted in the following ways:

- User must **not** attempt to access any SFR locations not defined.
- Accesses to any defined SFR locations must be strictly for the functions for the SFRs.
- SFR bits labeled '-', '0' or '1' can **only** be written and read as follows:
 - '-' Unless otherwise specified, **must** be written with '0', but can return any value when read (even if it was written with '0'). It is a reserved bit and may be used in future derivatives.
 - '0' **must** be written with '0', and will return a '0' when read.
 - '1' **must** be written with '1', and will return a '1' when read.

Table 7. P89LPC915 special function registers
** indicates SFRs that are bit addressable.*

Name	Description	SFR addr.	Bit functions and addresses										
			MSB										
			E7	E6	E5	E4	E3	E2	E1				
ACC*	Accumulator	E0H											
ADCON1	ADC control register 1	97H	ENB1	ENADCI 1	TMM1	EDGE1	ADCI1	ENADC1	ADCS11				
ADINS	ADC input select	A3H	ADI13	ADI12	ADI11	ADI10	-	-	-				
ADMODA	ADC mode register A	C0H	BNDI1	BURST1	SCC1	SCAN1	-	-	-				
ADMODB	ADC mode register B	A1H	CLK2	CLK1	CLK0	-	ENDAC1	-	BSA1				
AD1BH	A/D_1 boundary high register	C4H											
AD1BL	A/D_1 boundary low register	BCH											
AD1DAT0	A/D_1 data register 0	D5H											
AD1DAT1	A/D_1 data register 1	D6H											
AD1DAT2	A/D_1 data register 2	D7H											
AD1DAT3	A/D_1 data register 3	F5H											
AUXR1	Auxiliary function register	A2H	CLKLP	EBRR	-	ENT0	SRST	0	-	F7	F1		
			Bit address										
B*	B register	F0H											
BRGR0	Baud rate generator rate low	BEH											
BRGR1	Baud rate generator rate high	BFH											
BRGCON	Baud rate generator control	BDH	-	-	-	-	-	-	-	SBRGS			
CMP1	Comparator 1 control register	ACH	-	-	CE1	CP1	CN1	-	CO1				
CMP2	Comparator 2 control register	ADH	-	-	CE2	CP2	CN2	OE2	CO2				
DIVM	CPU clock divide-by-M control	95H											
DPTR	Data pointer (2 bytes)												
DPH	Data pointer high	83H											
DPL	Data pointer low	82H											
FMADRH	Program flash address high	E7H											
FMADRL	Program flash address low	E6H											

Table 7. P89LPC915 special function registers ... continued
** indicates SFRs that are bit addressable.*

Name	Description	SFR addr.	Bit functions and addresses													
			MSB													
FMCON	Program flash control (Read) Program flash control (Write)	E4H E4H	BUSY	-	-	HVA	HVE	SV	FMCMD. 7	FMCMD. 6	FMCMD. 5	FMCMD. 4	FMCMD. 3	FMCMD. 2	FMCMD. 1	
FMDATA	Program flash data	E5H														
I2ADR	I ² C slave address register	DBH														
I2CON*	I ² C control register	D8H	DF	DE	DD	DC	DB	DA	D9	I2ADR.6	I2ADR.5	I2ADR.4	I2ADR.3	I2ADR.2	I2ADR.1	I2ADR.0
I2DAT	I ² C data register	DAH	-	I2EN	STA	STO	SI	AA	-							
I2SCLH	Serial clock generator/SCL duty cycle register high	DDH														
I2SCLL	Serial clock generator/SCL duty cycle register low	DCH														
I2STAT	I ² C status register	D9H	STA.4	STA.3	STA.2	STA.1	STA.0	0	0	0	0	0	0	0	0	0
IEN0*	Interrupt enable 0	A8H	AF	AE	AD	AC	AB	AA	A9	EA	EWDRT	EBO	ES/ESR	ET1	EX1	ET0
IEN1*	Interrupt enable 1	E8H	EF	EE	ED	EC	EB	EA	E9	EAD	EST	-	-	EC	EKBI	EKBI
IP0*	Interrupt priority 0	B8H	BF	BE	BD	BC	BB	BA	B9	-	PWDRT	PBO	PS/PSR	PT1	PX1	PT0
IP0H	Interrupt priority 0 high	B7H	-	PWDRT H	PBOH	PSH/ PSRH	PT1H	PX1H	PT0H	-	PWDRT H	PBOH	PSH/ PSRH	PT1H	PX1H	PT0H
IP1*	Interrupt priority 1	F8H	FF	FE	FD	FC	FB	FA	F9	PAD	PST	-	-	PC	PKBI	PKBI
IP1H	Interrupt priority 1 high	F7H	PADH	PSTH	-	-	-	PCH	PKBIH	-	-	-	-	-	-	-
KBCON	Keypad control register	94H	-	-	-	-	-	-	PATN _SEL							
KBMASK	Keypad interrupt mask register	86H														
KBPATN	Keypad pattern register															

Table 7. P89LPC915 special function registers ... continued
** indicates SFRs that are bit addressable.*

Name	Description	SFR addr.	Bit functions and addresses																		
			MSB																		
P0*	Port 0	80H	Bit address	87	86	85	84	83	82	81											
				-	-	CMPREF /KB5	CIN1A /KB4	CIN1B /KB3	CIN2A /KB2	CIN2B /KB1											
P1*	Port 1	90H	Bit address	97	96	95	94	93	92	91											
				-	-	RST	INT1	INT0/ SDA	T0/SCL	RXD											
			Bit address	B7	B6	B5	B4	B3	B2	B1											
P0M1	Port 0 output mode 1	84H		-	-	(P0M1.5)	(P0M1.4)	(P0M1.3)	(P0M1.2)	(P0M1.1)											
P0M2	Port 0 output mode 2	85H		-	-	(P0M2.5)	(P0M2.4)	(P0M2.3)	(P0M2.2)	(P0M2.1)											
P1M1	Port 1 output mode 1	91H		-	-	-	(P1M1.4)	(P1M1.3)	(P1M1.2)	(P1M1.1)											
P1M2	Port 1 output mode 2	92H		-	-	-	(P1M2.4)	(P1M2.3)	(P1M2.2)	(P1M2.1)											
PCON	Power control register	87H	SMOD1	SMOD0	BOPD	BOI	ADPD	GF1	GF0	PMOD1											
PCONA	Power control register A	B5H	RTCPD	-	VCPD	ADPD	I2PD	-	SPD												
PSW*	Program status word	D0H	D7	D6	D5	D4	D3	D2	D1												
PT0AD	Port 0 digital input disable	F6H	CY	AC	F0	RS1	RS0	OV	F1												
RSTSRC	Reset source register	DFH	-	-	PT0AD.5	PT0AD.4	PT0AD.3	PT0AD.2	PT0AD.1												
RTCCON	RTC control	D1H	RTCF	RTCS1	RTCS0	-	-	-	ERTC												
RTCH	RTC register high	D2H																			
RTCL	RTC register low	D3H																			
SADDR	Serial port address register	A9H																			
SADEN	Serial port address enable	B9H																			
SBUF	Serial Port data buffer register	99H																			
SCON*	Serial port control	98H	9F	9E	9D	9C	9B	9A	99												
SSTAT	Serial port extended status register	BAH	SM0/FE	SM1	SM2	REN	TB8	RB8	TI												
SP	Stack pointer	81H	DBMOD	INTLO	CIDIS	DBISEL	FE	BR	OE												
TAMOD	Timer 0 and 1 auxiliary mode	8FH	-	-	-	-	-	-	-												

Table 8. P89LPC916 special function registers
** indicates SFRs that are bit addressable.*

Name	Description	SFR addr.	Bit functions and addresses													
			MSB													
		Bit address	E7	E6	E5	E4	E3	E2	E1	F7	F6	F5	F4	F3	F2	F1
ACC*	Accumulator	E0H														
ADCON1	ADC control register 1	97H	ENB1	ENADCI 1	TMM1	EDGE1	ADCI1	ENADC1	ADCS11							
ADINS	ADC input select	A3H	ADI13	ADI12	ADI11	ADI10	-	-	-							
ADMODA	ADC mode register A	C0H	BNDI1	BURST1	SCC1	SCAN1	-	-	-							
ADMODB	ADC mode register B	A1H	CLK2	CLK1	CLK0	-	ENDAC1	-	BSA1							
AD1BH	A/D_1 boundary high register	C4H														
AD1BL	A/D_1 boundary low register	BCH														
AD1DAT0	A/D_1 data register 0	D5H														
AD1DAT1	A/D_1 data register 1	D6H														
AD1DAT2	A/D_1 data register 2	D7H														
AD1DAT3	A/D_1 data register 3	F5H														
AUXR1	Auxiliary function register	A2H	CLKLP	EBRR	-	ENT0	SRST	0	-							
B*	B register	F0H														
BRGR0	Baud rate generator rate low	BEH														
BRGR1	Baud rate generator rate high	BFH														
BRGCON	Baud rate generator control	BDH	-	-	-	-	-	-	SBRGS							
CMP1	Comparator 1 control register	ACH	-	-	CE1	CP1	CN1	-	CO1							
CMP2	Comparator 2 control register	ADH	-	-	CE2	CP2	CN2	OE2	CO2							
DIVM	CPU clock divide-by-M control	95H														
DPTR	Data pointer (2 bytes)															
DPH	Data pointer high	83H														
DPL	Data pointer low	82H														
FMADRH	Program flash address high	E7H														
FMADRL	Program flash address low	E6H														

Table 8. P89LPC916 special function registers ... continued
** indicates SFRs that are bit addressable.*

Name	Description	SFR addr.	Bit functions and addresses									
			MSB									
FMCON	Program flash control (Read)	E4H	BUSY	-	-	HVA	HVE	SV				
	Program flash control (Write)	E4H	FMCMD. 7	FMCMD. 6	FMCMD. 5	FMCMD. 4	FMCMD. 3	FMCMD. 2	FMCMD. 1			
FMDATA	Program flash data	E5H										
I2ADR	I ² C slave address register	DBH	I2ADR.6	I2ADR.5	I2ADR.4	I2ADR.3	I2ADR.2	I2ADR.1	I2ADR.0			
I2CON*	I ² C control register	D8H	DF	DE	DD	DC	DB	DA	D9			
			-	I2EN	STA	STO	SI	AA				
I2DAT	I ² C data register	DAH										
I2SCLH	Serial clock generator/SCL duty cycle register high	DDH										
I2SCLL	Serial clock generator/SCL duty cycle register low	DCH										
I2STAT	I ² C status register	D9H	STA.4	STA.3	STA.2	STA.1	STA.0	0	0	0		
IEN0*	Interrupt enable 0	A8H	AF	AE	AD	AC	AB	AA	A9			
			EA	EWDRT	EBO	ES/ESR	ET1	-	ET0			
IEN1*	Interrupt enable 1	E8H	EF	EE	ED	EC	EB	EA	E9			
			EAD	EST	-	-	ESPI	EC	EKBI			
IP0*	Interrupt priority 0	B8H	BF	BE	BD	BC	BB	BA	B9			
			-	PWDRT	PBO	PS/PSR	PT1	-	PT0			
IP0H	Interrupt priority 0 high	B7H	-	PWDRT H	PBOH	PSH/PSRH	PT1H	-	PT0H			
			FF	FE	FD	FC	FB	FA	F9			
IP1*	Interrupt priority 1	F8H	PAD	PST	-	-	PSPI	PC	PKBI			
IP1H	Interrupt priority 1 high	F7H	PADH	PSTH	-	-	PSPIH	PCH	PKBIH			
KBCON	Keypad control register	94H	-	-	-	-	-	-	PATN	_SEL		
KBMASK	Keypad interrupt mask register	86H										
KBPATN	Keypad pattern register											

Table 8. P89LPC916 special function registers ... continued
** indicates SFRs that are bit addressable.*

Name	Description	SFR addr.	Bit functions and addresses									
			MSB									
P0*	Port 0	80H	Bit address	87	86	85	84	83	82	81		
				-	-	CMPREF /KB5	CIN1A /KB4	CIN1B /KB3	CIN2A /KB2	CIN2B /KB1		
P1*	Port 1	90H	Bit address	97	96	95	94	93	92	91		
				-	-	RST	-	INT0/ SDA	T0/SCL	RXD		
P2*	Port 2	A0H	Bit address	A7	A6	A5	A4	A3	A2	A1		
P0M1	Port 0 output mode 1	84H		-	-	SPICLK	SS	MISO	MOSI	-		
P0M2	Port 0 output mode 2	85H		(P0M1.7)	(P0M1.6)	(P0M1.5)	(P0M1.4)	(P0M1.3)	(P0M1.2)	(P0M1.1)		
P1M1	Port 1 output mode 1	91H		(P0M2.7)	(P0M2.6)	(P0M2.5)	(P0M2.4)	(P0M2.3)	(P0M2.2)	(P0M2.1)		
P1M2	Port 1 output mode 2	92H		(P1M1.7)	(P1M1.6)	-	(P1M1.4)	(P1M1.3)	(P1M1.2)	(P1M1.1)		
P2M1	Port 2 output mode 1	A4H		(P1M2.7)	(P1M2.6)	-	(P1M2.4)	(P1M2.3)	(P1M2.2)	(P1M2.1)		
P2M2	Port 2 output mode 2	A5H		-	-	(P2M1.5)	(P2M1.4)	(P2M1.3)	(P2M1.2)	-		
PCON	Power control register	87H		-	-	(P2M2.5)	(P2M2.4)	(P2M2.3)	(P2M2.2)	-		
PCONA	Power control register A	B5H		SMOD1	SMOD0	BOPD	BOI	GF1	GF0	PMOD1		
				RTCPD	-	VCPD	ADPD	I2PD	SPPD	SPD		
PSW*	Program status word	D0H	Bit address	D7	D6	D5	D4	D3	D2	D1		
PT0AD	Port 0 digital input disable	F6H		CY	AC	F0	RS1	RS0	OV	F1		
RSTSRC	Reset source register	DFH		-	-	PT0AD.5	PT0AD.4	PT0AD.3	PT0AD.2	PT0AD.1		
RTCCON	RTC control	D1H		-	-	BOF	POF	R_BK	R_WD	R_SF		
				RTCF	RTCS1	RTCS0	-	-	-	ERTC		
RTCH	RTC register high	D2H										
RTCL	RTC register low	D3H										
SADDR	Serial port address register	A9H										
SADEN	Serial port address enable	B9H										
SBUF	Serial Port data buffer register	99H										
SCON*	Serial port control	98H	Bit address	9F	9E	9D	9C	9B	9A	99		
				SM0/FE	SM1	SM2	REN	TB8	RB8	TI		

Table 9. P89LPC917 special function registers
** indicates SFRs that are bit addressable.*

Name	Description	SFR addr.	Bit functions and addresses														
			MSB														
			E7	E6	E5	E4	E3	E2	E1								
ACC*	Accumulator	E0H															
ADCON1	ADC control register 1	97H	ENB1	ENADCI 1	TMM1	EDGE1	ADCI1	ENADC1	ADCS11								
ADINS	ADC input select	A3H	ADI13	ADI12	ADI11	ADI10	-	-	-	-							
ADMODA	ADC mode register A	C0H	BNDI1	BURST1	SCC1	SCAN1	-	-	-	-							
ADMODB	ADC mode register B	A1H	CLK2	CLK1	CLK0	-	ENDAC1	-	-	BSA1							
AD1BH	A/D_1 boundary high register	C4H															
AD1BL	A/D_1 boundary low register	BCH															
AD1DAT0	A/D_1 data register 0	D5H															
AD1DAT1	A/D_1 data register 1	D6H															
AD1DAT2	A/D_1 data register 2	D7H															
AD1DAT3	A/D_1 data register 3	F5H															
AUXR1	Auxiliary function register	A2H	CLKLP	EBRR	ENT1	ENT0	SRST	0	-	-	F7	F6	F5	F4	F3	F2	F1
B*	B register	F0H															
BRGR0	Baud rate generator rate low	BEH															
BRGR1	Baud rate generator rate high	BFH															
BRGCON	Baud rate generator control	BDH	-	-	-	-	-	-	-	-	-	-	-	-	-	-	SBRGS
CMP1	Comparator 1 control register	ACH	-	-	CE1	CP1	CN1	-	-	-	-	-	-	-	-	-	CO1
CMP2	Comparator 2 control register	ADH	-	-	CE2	CP2	CN2	OE2	CO2								
DIVM	CPU clock divide-by-M control	95H															
DPTR	Data pointer (2 bytes)																
DPH	Data pointer high	83H															
DPL	Data pointer low	82H															
FMADRH	Program flash address high	E7H															
FMADRL	Program flash address low	E6H															

Table 9. P89LPC917 special function registers ... continued
** indicates SFRs that are bit addressable.*

Name	Description	SFR addr.	Bit functions and addresses									
			MSB									
FMCON	Program flash control (Read)	E4H	BUSY	-	-	HVA	HVE	SV				
	Program flash control (Write)	E4H	FMCMD. 7	FMCMD. 6	FMCMD. 5	FMCMD. 4	FMCMD. 3	FMCMD. 2	FMCMD. 1			
FMDATA	Program flash data	E5H										
I2ADR	I ² C slave address register	DBH	I2ADR.6	I2ADR.5	I2ADR.4	I2ADR.3	I2ADR.2	I2ADR.1	I2ADR.0			
I2CON*	I ² C control register	D8H	DF	DE	DD	DC	DB	DA	D9			
I2DAT	I ² C data register	DAH	-	I2EN	STA	STO	SI	AA				
I2SCLH	Serial clock generator/SCL duty cycle register high	DDH										
I2SCLL	Serial clock generator/SCL duty cycle register low	DCH										
I2STAT	I ² C status register	D9H	STA.4	STA.3	STA.2	STA.1	STA.0	0	0	0		
IEN0*	Interrupt enable 0	A8H	AF	AE	AD	AC	AB	AA	A9			
IEN1*	Interrupt enable 1	E8H	EA	EE	ED	EC	EB	EA	E9			
IP0*	Interrupt priority 0	B8H	EAD	EST	-	-	EC	EC	EKBI			
IP0H	Interrupt priority 0 high	B7H	BF	BE	BD	BC	BB	BA	B9			
			-	PWDRT	PBO	PS/PSR	PT1	PX1	PT0			
			-	PWDRT H	PBOH	PSH/PSRH	PT1H	PX1H	PT0H			
IP1*	Interrupt priority 1	F8H	FF	FE	FD	FC	FB	FA	F9			
IP1H	Interrupt priority 1 high	F7H	PAD	PST	-	-	-	PC	PKBI			
KBCON	Keypad control register	94H	PADH	PSTH	-	-	-	PCH	PKBIH			
KBMASK	Keypad interrupt mask register	86H	-	-	-	-	-	-	PATN			
KBPATN	Keypad pattern register		_SEL									

Table 9. P89LPC917 special function registers ... continued
** indicates SFRs that are bit addressable.*

Name	Description	SFR addr.	Bit functions and addresses																	
			MSB																	
P0*	Port 0	80H	Bit address	87	86	85	84	83	82	81										
				T1/KB7/ CLKOUT	-	CMPREF /KB5	CIN1A /KB4	CIN1B /KB3	CIN2A /KB2	CIN2B /KB1										
P1*	Port 1	90H	Bit address	97	96	95	94	93	92	91										
				-	-	RST	INT1	INT0/ SDA	T0/SCL	RXD										
P0M1	Port 0 output mode 1	84H	Bit address	B7	B6	B5	B4	B3	B2	B1										
P0M2	Port 0 output mode 2	85H		(P0M1.7)	-	(P0M1.5)	(P0M1.4)	(P0M1.3)	(P0M1.2)	(P0M1.1)										
P1M1	Port 1 output mode 1	91H		(P0M2.7)	-	(P0M2.5)	(P0M2.4)	(P0M2.3)	(P0M2.2)	(P0M2.1)										
P1M2	Port 1 output mode 2	92H		-	-	-	(P1M1.4)	(P1M1.3)	(P1M1.2)	(P1M1.1)										
PCON	Power control register	87H		-	-	-	(P1M2.4)	(P1M2.3)	(P1M2.2)	(P1M2.1)										
PCONA	Power control register A	B5H		SMOD1	SMOD0	BOPD	BOI	GF1	GF0	PMOD1										
PSW*	Program status word	D0H	Bit address	RTCPD	-	VCPD	ADPD	I2PD	-	SPD										
PT0AD	Port 0 digital input disable	F6H		D7	D6	D5	D4	D3	D2	D1										
RSTSRC	Reset source register	DFH		CY	AC	F0	RS1	RS0	OV	F1										
RTCCON	RTC control	D1H		-	-	PT0AD.5	PT0AD.4	PT0AD.3	PT0AD.2	PT0AD.1										
RTCH	RTC register high	D2H		-	-	BOF	POF	R_BK	R_WD	R_SF										
RTCL	RTC register low	D3H		RTCF	RTCS1	RTCS0	-	-	-	ERTC										
SADDR	Serial port address register	A9H																		
SADEN	Serial port address enable	B9H																		
SBUF	Serial Port data buffer register	99H																		
SCON*	Serial port control	98H	Bit address	9F	9E	9D	9C	9B	9A	99										
SSTAT	Serial port extended status register	BAH		SM0/FE	SM1	SM2	REN	TB8	RB8	TI										
SP	Stack pointer	81H		DBMOD	INTLO	CIDIS	DBISEL	FE	BR	OE										
TAMOD	Timer 0 and 1 auxiliary mode	8FH		-	-	-	T1M2	-	-	-										

Table 9. P89LPC917 special function registers ... continued
** indicates SFRs that are bit addressable.*

Name	Description	SFR addr.	Bit functions and addresses															
			MSB															
			Bit address															
TCON*	Timer 0 and 1 control	88H	8F	8E	8D	8C	8B	8A	89	TF1	TR1	TF0	TR0	IE1	IT1	IE0		
TH0	Timer 0 high	8CH																
TH1	Timer 1 high	8DH																
TL0	Timer 0 low	8AH																
TL1	Timer 1 low	8BH																
TMOD	Timer 0 and 1 mode	89H	T1GATE	T1C/T	T1M1	T1M0	T0GATE	T0C/T	T0M1									
TRIM	Internal oscillator trim register	96H	RCCLK	ENCLK	TRIM.5	TRIM.4	TRIM.3	TRIM.2	TRIM.1									
WDCON	Watchdog control register	A7H	PRE2	PRE1	PRE0	-	-	WDRUN	WDTOF									
WDL	Watchdog load	C1H																
WFEED1	Watchdog feed 1	C2H																
WFEED2	Watchdog feed 2	C3H																

[1] All ports are in input only (high-impedance) state after power-up.

[2] BRGR1 and BRGR0 must only be written if BRGEN in BRGCON SFR is logic 0. If any are written while BRGEN = 1, the result is unpredictable.

[3] The RSTSRC register reflects the cause of the P89LPC915/916/917 reset. Upon a power-up reset, all reset source flags are cleared except P value is xx11 0000.

[4] After reset, the value is 1110 01x1, i.e., PRE2 to PRE0 are all logic 1, WDRUN = 1 and WDCLK = 1. WDTOF bit is logic 1 after watchdog reset. Other resets will not affect WDTOF.

[5] On power-on reset, the TRIM SFR is initialized with a factory preprogrammed value. Other resets will not cause initialization of the TRIM registers.

[6] The only reset source that affects these SFRs is power-on reset.

8.2 Enhanced CPU

The P89LPC915/916/917 uses an enhanced 80C51 CPU which runs at six times the speed of standard 80C51 devices. A machine cycle consists of two CPU clock cycles, and most instructions execute in one or two machine cycles.

8.3 Clocks

8.3.1 Clock definitions

The P89LPC915/916/917 device has several internal clocks as defined below:

OSCCLK — Input to the DIVM clock divider. OSCCLK is selected from one of four clock sources (see [Figure 11](#)) and can also be optionally divided to a slower frequency (see [Section 8.8 “CCLK modification: DIVM register”](#)).

Note: f_{osc} is defined as the OSCCLK frequency.

CCLK — CPU clock; output of the clock divider. There are two CCLK cycles per machine cycle, and most instructions are executed in one to two machine cycles (two or four CCLK cycles).

RCCLK — The internal 7.373 MHz RC oscillator output.

PCLK — Clock for the various peripheral devices and is $CCLK/2$.

8.3.2 CPU clock (OSCCLK)

The P89LPC915/916/917 provides several user-selectable oscillator options in generating the CPU clock. This allows optimization for a range of needs from high precision to lowest possible cost. These options are configured when the flash is programmed and include an on-chip watchdog oscillator, an on-chip RC oscillator, and an external clock source.

8.3.3 Clock output (P89LPC917)

The P89LPC917 supports a user-selectable clock output function on the CLKOUT pin. This allows external devices to synchronize to the P89LPC917. This output is enabled by the ENCLK bit in the TRIM register.

The frequency of this clock output is $1/2$ that of the CCLK. If the clock output is not needed in Idle mode, it may be turned off prior to entering Idle, saving additional power.

8.4 On-chip RC oscillator option

The P89LPC915/916/917 has a 6-bit TRIM register that can be used to tune the frequency of the RC oscillator. During reset, the TRIM value is initialized to a factory pre-programmed value to adjust the oscillator frequency to 7.373 MHz \pm 1 % at room temperature. End-user applications can write to the TRIM register to adjust the on-chip RC oscillator to other frequencies. If CCLK is 8 MHz or slower, the CLKLP SFR bit (AUXR1.7) can be set to logic 1 to reduce power consumption. On reset, CLKLP is logic 0 allowing highest performance access. This bit can then be set in software if CCLK is running at 8 MHz or slower.

8.5 Watchdog oscillator option

The watchdog has a separate oscillator which has a frequency of 400 kHz. This oscillator can be used to save power when a high clock frequency is not needed.

8.6 External clock input option

In this configuration, the processor clock is derived from an external source driving the CLKIN pin. The rate may be from 0 Hz up to 18 MHz.

When using an external clock input frequency above 12 MHz, the reset input function of P1.5 must be enabled. An external circuit is required to hold the device in reset at power-up until V_{DD} has reached its specified level. When system power is removed V_{DD} will fall below the minimum specified operating voltage. When using an external clock input frequency above 12 MHz, in some applications, an external brownout detect circuit may be required to hold the device in reset when V_{DD} falls below the minimum specified operating voltage.

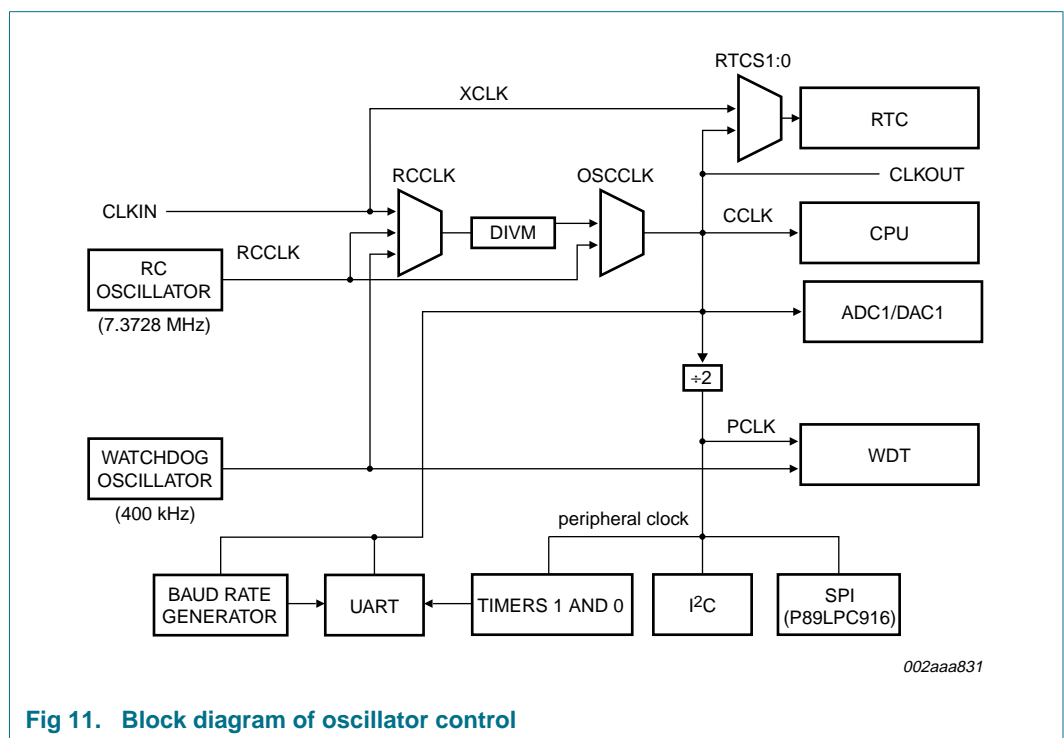

Fig 11. Block diagram of oscillator control

8.7 CCLK wake-up delay

The P89LPC915/916/917 has an internal wake-up timer that delays the clock until it stabilizes. The delay is 224 OSCCLK cycles plus 60 μs to 100 μs.

8.8 CCLK modification: DIVM register

The OSCCLK frequency can be divided down up to 510 times by configuring a dividing register, DIVM, to generate CCLK. This feature makes it possible to temporarily run the CPU at a lower rate, reducing power consumption. By dividing the clock, the CPU can retain the ability to respond to events that would not exit Idle mode by executing its normal program at a lower rate. This can also allow bypassing the oscillator start-up time in cases where Power-down mode would otherwise be used. The value of DIVM may be changed by the program at any time without interrupting code execution.

8.9 Low power select

The P89LPC915/916/917 is designed to run at 18 MHz (CCLK) maximum. However, if CCLK is 8 MHz or slower, the CLKLP SFR bit (AUXR1.7) can be set to '1' to lower the power consumption further. On any reset, CLKLP is '0' allowing highest performance access. This bit can then be set in software if CCLK is running at 8 MHz or slower.

8.10 Memory organization

The various P89LPC915/916/917 memory spaces are as follows:

- DATA
128 bytes of internal data memory space (00H:7FH) accessed via direct or indirect addressing, using instructions other than MOVX and MOVC. All or part of the Stack may be in this area.
- IDATA
Indirect Data. 256 bytes of internal data memory space (00H:FFH) accessed via indirect addressing using instructions other than MOVX and MOVC. All or part of the Stack may be in this area. This area includes the DATA area and the 128 bytes immediately above it.
- SFR
Special Function Registers. Selected CPU registers and peripheral control and status registers, accessible only via direct addressing.
- CODE
64 kB of Code memory space, accessed as part of program execution and via the MOVC instruction. The P89LPC915/916/917 devices have 2 kB of on-chip Code memory.

8.11 Data RAM arrangement

The 256 bytes of on-chip RAM are organized as shown in [Table 10](#).

Table 10. On-chip data memory usages

Type	Data RAM	Size (bytes)
DATA	Memory that can be addressed directly and indirectly	128
IDATA	Memory that can be addressed indirectly	256

8.12 Interrupts

The P89LPC915/916/917 uses a four priority level interrupt structure. This allows great flexibility in controlling the handling of the many interrupt sources.

The P89LPC915 and P89LPC917 support 13 interrupt sources: external interrupts 0 and 1, timers 0 and 1, serial port TX, serial port RX, combined serial port RX/TX, brownout detect, watchdog/RTC, I²C-bus, keyboard, comparators 1 and 2, and ADC completion.

The P89LPC916 supports 14 interrupt sources: external interrupts 0 and 1, timers 0 and 1, serial port TX, serial port RX, combined serial port RX/TX, brownout detect, watchdog/RTC, I²C-bus, keyboard, comparators 1 and 2, SPI, and ADC completion.

Each interrupt source can be individually enabled or disabled by setting or clearing a bit in the interrupt enable registers IEN0 or IEN1. The IEN0 register also contains a global disable bit, EA, which disables all interrupts.

Each interrupt source can be individually programmed to one of four priority levels by setting or clearing bits in the interrupt priority registers IP0, IP0H, IP1, and IP1H. An interrupt service routine in progress can be interrupted by a higher priority interrupt, but not by another interrupt of the same or lower priority. The highest priority interrupt service cannot be interrupted by any other interrupt source. If two requests of different priority levels are pending at the start of an instruction, the request of higher priority level is serviced.

If requests of the same priority level are pending at the start of an instruction, an internal polling sequence determines which request is serviced. This is called the arbitration ranking. Note that the arbitration ranking is only used to resolve pending requests of the same priority level.

8.12.1 External interrupt inputs

The P89LPC915 and P89LPC917 have two external interrupt inputs. The P89LPC916 has one external interrupt input. These external interrupt inputs are identical to those present on the standard 80C51 microcontrollers. All three devices also have the Keypad Interrupt function.

These external interrupts can be programmed to be level-triggered or edge-triggered by setting or clearing bit IT1 or IT0 in Register TCON.

In edge-triggered mode, if successive samples of the $\overline{\text{INTn}}$ pin show a HIGH in one cycle and a LOW in the next cycle, the interrupt request flag IEn in TCON is set, causing an interrupt request.

If an external interrupt is enabled when the P89LPC915/916/917 is put into Power-down or Idle mode, the interrupt will cause the processor to wake-up and resume operation. Refer to [Section 8.15 "Power reduction modes"](#) for details.

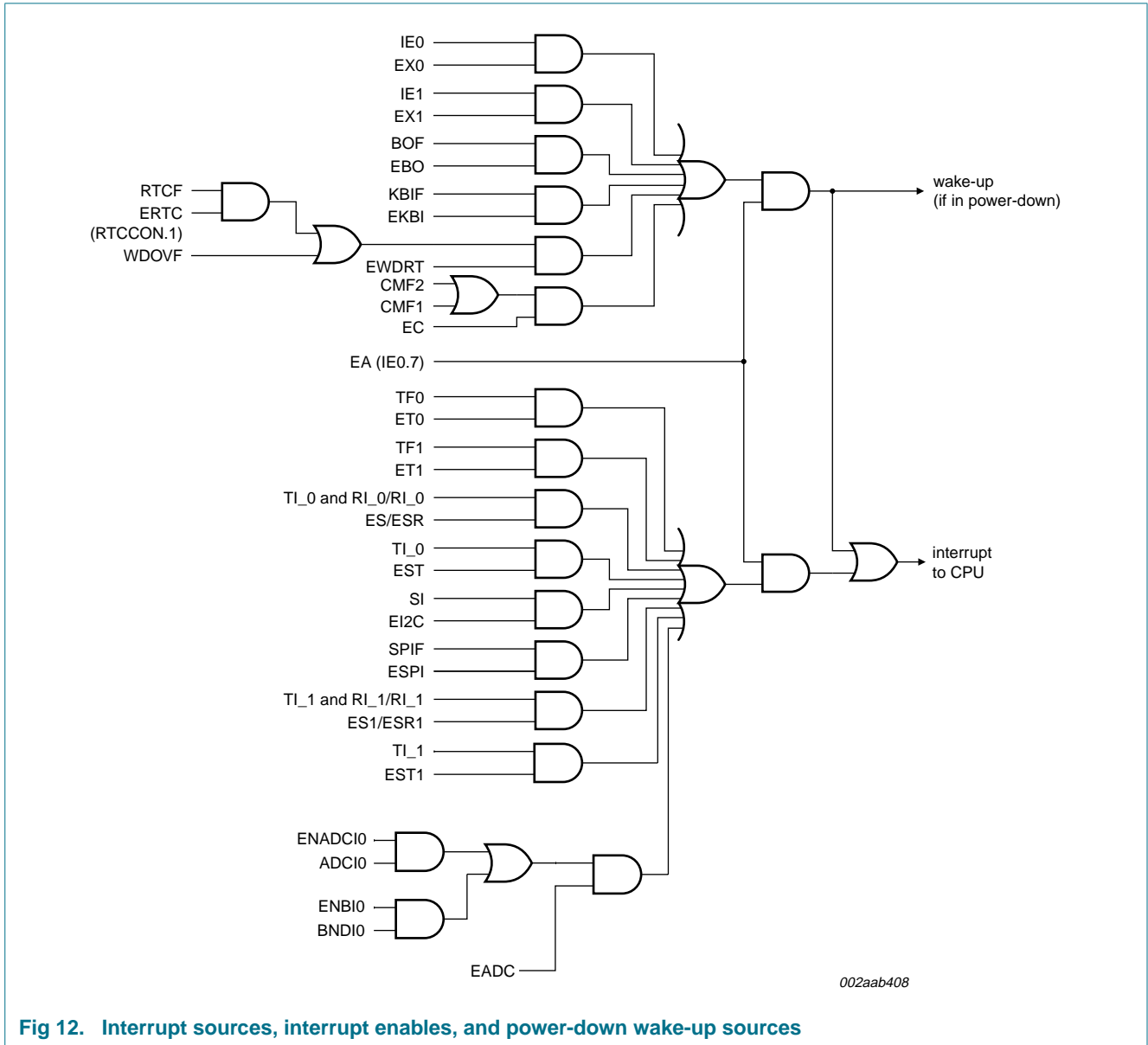

Fig 12. Interrupt sources, interrupt enables, and power-down wake-up sources

8.13 I/O ports

The P89LPC916 and P89LPC917 devices have three I/O ports: Port 0, Port 1, and Port 2. The exact number of I/O pins available depends upon the clock and reset options chosen, as shown in [Table 11](#).

Table 11. Number of I/O pins available (P89LPC916 and P89LPC917)

Clock source	Reset option	Number of I/O pins (16-pin package)
RC oscillator or watchdog oscillator	No external reset (except during power-up)	14
	External $\overline{\text{RST}}$ pin supported	13
External clock input	No external reset (except during power-up)	13
	External $\overline{\text{RST}}$ pin supported ^[1]	12

[1] Required for operation above 12 MHz.

The P89LPC915 has two I/O ports: Port 0 and Port 1. The exact number of I/O pins available depends upon the clock and reset options chosen, as shown in [Table 12](#).

Table 12. Number of I/O pins available (P89LPC915)

Clock source	Reset option	Number of I/O pins (14-pin package)
RC oscillator or watchdog oscillator	No external reset (except during power-up)	12
	External $\overline{\text{RST}}$ pin supported	11
External clock input	No external reset (except during power-up)	11
	External $\overline{\text{RST}}$ pin supported ^[1]	10

[1] Required for operation above 12 MHz.

8.13.1 Port configurations

All but three I/O port pins on the P89LPC915/916/917 may be configured by software to one of four types on a bit-by-bit basis. These are: quasi-bidirectional (standard 80C51 port outputs), push-pull, open drain, and input-only. Two configuration registers for each port select the output type for each port pin.

1. P1.5 ($\overline{\text{RST}}$) can only be an input and cannot be configured.
2. P1.2 (SCL/T0) and P1.3 (SDA/ $\overline{\text{INT0}}$) may only be configured to be either input-only or open-drain.

8.13.1.1 Quasi-bidirectional output configuration

Quasi-bidirectional output type can be used as both an input and output without the need to reconfigure the port. This is possible because when the port outputs a logic HIGH, it is weakly driven, allowing an external device to pull the pin LOW. When the pin is driven LOW, it is driven strongly and able to sink a fairly large current. These features are somewhat similar to an open-drain output except that there are three pull-up transistors in the quasi-bidirectional output that serve different purposes.

The P89LPC915/916/917 is a 3 V device, but the pins are 5 V tolerant. In quasi-bidirectional mode, if a user applies 5 V on the pin, there will be a current flowing from the pin to V_{DD} , causing extra power consumption. Therefore, applying 5 V in quasi-bidirectional mode is discouraged.

A quasi-bidirectional port pin has a Schmitt triggered input that also has a glitch suppression circuit.

8.13.1.2 Open-drain output configuration

The open-drain output configuration turns off all pull-ups and only drives the pull-down transistor of the port driver when the port latch contains a logic 0. To be used as a logic output, a port configured in this manner must have an external pull-up, typically a resistor tied to V_{DD} .

An open-drain port pin has a Schmitt triggered input that also has a glitch suppression circuit.

8.13.1.3 Input-only configuration

The input-only port configuration has no output drivers. It is a Schmitt triggered input that also has a glitch suppression circuit.

8.13.1.4 Push-pull output configuration

The push-pull output configuration has the same pull-down structure as both the open-drain and the quasi-bidirectional output modes, but provides a continuous strong pull-up when the port latch contains a logic 1. The push-pull mode may be used when more source current is needed from a port output. A push-pull port pin has a Schmitt triggered input that also has a glitch suppression circuit.

8.13.2 Port 0 analog functions

The P89LPC915/916/917 incorporates two Analog Comparators. In order to give the best analog function performance and to minimize power consumption, pins that are being used for analog functions must have the digital outputs and digital inputs disabled.

Digital outputs are disabled by putting the port output into the Input-Only (high-impedance) mode.

Digital inputs on Port 0 may be disabled through the use of the PT0AD register. On any reset, PT0AD bits default to '0's to enable digital functions.

8.13.3 Additional port features

After power-up, all pins are in Input-Only mode. After power-up, all I/O pins except P1.5, may be configured by software.

- Pin P1.5 is input only.
- Pins P1.2 and P1.3 are configurable for either input-only or open-drain.

Every output on the P89LPC915/916/917 has been designed to sink typical LED drive current. However, there is a maximum total output current for all ports which must not be exceeded. Please refer to [Table 15 "Static characteristics"](#) for detailed specifications.

All ports pins that can function as an output have slew rate controlled outputs to limit noise generated by quickly switching output signals. The slew rate is factory-set to approximately 10 ns rise and fall times.

8.14 Power monitoring functions

The P89LPC915/916/917 incorporates power monitoring functions designed to prevent incorrect operation during initial power-up and power loss or reduction during operation. This is accomplished with two hardware functions: Power-on detect and brownout detect.

8.14.1 Brownout detection

The brownout detect function determines if the power supply voltage drops below a certain level. The default operation is for a brownout detection to cause a processor reset, however it may alternatively be configured to generate an interrupt.

Brownout detection may be enabled or disabled in software.

If brownout detection is enabled the brownout condition occurs when V_{DD} falls below the brownout trip voltage, V_{bo} (see [Table 15 "Static characteristics"](#)), and is negated when V_{DD} rises above V_{bo} . If the P89LPC915/916/917 device is to operate with a power supply that can be below 2.7 V, BOE should be left in the unprogrammed state so that the device can operate at 2.4 V, otherwise continuous brownout reset may prevent the device from operating.

For correct activation of brownout detect, the V_{DD} rise and fall times must be observed. Please see [Table 15 "Static characteristics"](#) for specifications.

8.14.2 Power-on detection

The Power-on detect has a function similar to the brownout detect, but is designed to work as power comes up initially, before the power supply voltage reaches a level where brownout detect can work. The POF flag in the RSTSRC register is set to indicate an initial power-up condition. The POF flag will remain set until cleared by software.

8.15 Power reduction modes

The P89LPC915/916/917 supports three different power reduction modes: Idle mode, Power-down mode, and total Power-down mode.

8.15.1 Idle mode

Idle mode leaves peripherals running in order to allow them to activate the processor when an interrupt is generated. Any enabled interrupt source or reset may terminate Idle mode.

8.15.2 Power-down mode

The Power-down mode stops the oscillator in order to minimize power consumption. The P89LPC915/916/917 exits Power-down mode via any reset, or certain interrupts. In Power-down mode, the power supply voltage may be reduced to the data retention voltage V_{DDR} . This retains the RAM contents at the point where Power-down mode was entered. SFR contents are not guaranteed after V_{DD} has been lowered to V_{DDR} , therefore it is highly recommended to wake-up the processor via reset in this case. V_{DD} must be raised to within the operating range before the Power-down mode is exited.

Some chip functions continue to operate and draw power during Power-down mode, increasing the total power used during power-down. These include: Brownout detect, watchdog timer, comparators (note that comparators can be powered down separately), and RTC/system timer. The internal RC oscillator is disabled unless both the RC oscillator has been selected as the system clock and the RTC is enabled.

8.15.3 Total Power-down mode

This is the same as Power-down mode except that the brownout detection circuitry and the voltage comparators are also disabled to conserve additional power. The internal RC oscillator is disabled unless both the RC oscillator has been selected as the system clock **and** the RTC is enabled. If the internal RC oscillator is used to clock the RTC during power-down, there will be high power consumption. Please use an external low frequency clock to achieve low power with the RTC running during power-down.

8.16 Reset

The P1.5/ $\overline{\text{RST}}$ pin can function as either an active-LOW reset input or as a digital input, P1.5. The RPE (Reset Pin Enable) bit in UCFG1, when set to '1', enables the external reset input function on P1.5. When cleared, P1.5 may be used as an input pin.

Remark: During a power-up sequence, the RPE selection is overridden and this pin always functions as a reset input. **An external circuit connected to this pin should not hold this pin LOW during a power-on sequence as this will keep the device in reset.** After power-up this input will function either as an external reset input or as a digital input as defined by the RPE bit. Only a power-up reset will temporarily override the selection defined by RPE bit. Other sources of reset will not override the RPE bit.

Reset can be triggered from the following sources:

- External reset pin (during power-up or if user configured via UCFG1);
- Power-on detect;
- Brownout detect;
- Watchdog timer;
- Software reset;
- UART break character detect reset.

For every reset source, there is a flag in the Reset Register, RSTSRC. The user can read this register to determine the most recent reset source. These flag bits can be cleared in software by writing a '0' to the corresponding bit. More than one flag bit may be set:

- During a power-on reset, both POF and BOF are set but the other flag bits are cleared.
- For any other reset, previously set flag bits that have not been cleared will remain set.

8.17 Timers/counters 0 and 1

The P89LPC915/916/917 have two general purpose counter/timers which are upward compatible with the standard 80C51 Timer 0 and Timer 1. Both can be configured to operate either as timers or event counters. An option to automatically toggle the T0 and/or T1 pins upon timer overflow has been added.

In the 'Timer' function, the register is incremented every machine cycle.

In the 'Counter' function, the register is incremented in response to a 1-to-0 transition at its corresponding external input pin, T0 or T1. In this function, the external input is sampled once during every machine cycle.

Timer 0 has five operating modes (Modes 0, 1, 2, 3 and 6).

Timer 1 has four operating modes (Modes 0, 1, 2, and 3), except on the P89LPC917 where Timer 1 also has Mode 6. Modes 0, 1, 2 and 6 are the same for both Timers/Counters. Mode 3 is different.

8.17.1 Mode 0

Putting either Timer into Mode 0 makes it look like an 8048 Timer, which is an 8-bit Counter with a divide-by-32 prescaler. In this mode, the Timer register is configured as a 13-bit register. Mode 0 operation is the same for Timer 0 and Timer 1.

8.17.2 Mode 1

Mode 1 is the same as Mode 0, except that all 16 bits of the timer register are used.

8.17.3 Mode 2

Mode 2 configures the Timer register as an 8-bit Counter with automatic reload. Mode 2 operation is the same for Timer 0 and Timer 1.

8.17.4 Mode 3

When Timer 1 is in Mode 3 it is stopped. Timer 0 in Mode 3 forms two separate 8-bit counters and is provided for applications that require an extra 8-bit timer. When Timer 1 is in Mode 3 it can still be used by the serial port as a baud rate generator.

8.17.5 Mode 6

In this mode, the corresponding timer can be changed to a PWM with a full period of 256 timer clocks.

8.17.6 Timer overflow toggle output

Timer 0 (and Timer 1 on the P89LPC917) can be configured to automatically toggle a port output whenever a timer overflow occurs. The same device pins that are used for the T0 and T1 count inputs are also used for the timer toggle outputs. The port outputs will be a logic 1 prior to the first timer overflow when this mode is turned on.

8.18 RTC/system timer

The P89LPC915/916/917 have a simple RTC that allows a user to continue running an accurate timer while the rest of the device is powered down. The RTC can be a wake-up or an interrupt source. The RTC is a 23-bit down-counter comprised of a 7-bit prescaler and a 16-bit loadable down-counter. When it reaches all '0's, the counter will be reloaded again and the RTCF flag will be set.

The clock source for this counter can be either the CPU clock (CCLK) or the external clock input, provided that the external clock input is not being used as the CPU clock. If the external clock input is used as the CPU clock, then the RTC will use CCLK as its clock source. Only power-on reset will reset the RTC and its associated SFRs to the default state.

8.19 UART

The P89LPC915/916/917 has an enhanced UART that is compatible with the conventional 80C51 UART except that Timer 2 overflow cannot be used as a baud rate source. The P89LPC915/916/917 does include an independent Baud Rate Generator. The baud rate can be selected from the oscillator (divided by a constant), Timer 1 overflow, or the independent Baud Rate Generator. In addition to the baud rate generation, enhancements over the standard 80C51 UART include Framing Error detection, automatic address recognition, selectable double buffering and several interrupt options. The UART can be operated in 4 modes: shift register, 8-bit UART, 9-bit UART, and CPU clock/32 or CPU clock/16.

8.19.1 Mode 0

Serial data enters and exits through RXD. TXD outputs the shift clock. 8 bits are transmitted or received, LSB first. The baud rate is fixed at $\frac{1}{16}$ of the CPU clock frequency.

8.19.2 Mode 1

10 bits are transmitted (through TXD) or received (through RXD): a start bit (logic 0), 8 data bits (LSB first), and a stop bit (logic 1). When data is received, the stop bit is stored in RB8_n in Special Function Register SnCON. The baud rate is variable and is determined by the Timer 1 overflow rate or the Baud Rate Generator (described in [Section 8.19.5 “Baud rate generator and selection”](#)).

8.19.3 Mode 2

11 bits are transmitted (through TXD) or received (through RXD): start bit (logic 0), 8 data bits (LSB first), a programmable 9th data bit, and a stop bit (logic 1). When data is transmitted, the 9th data bit (TB8 in SCON) can be assigned the value of ‘0’ or ‘1’. Or, for example, the parity bit (P, in the PSW) could be moved into TB8. When data is received, the 9th data bit goes into RB8 in Special Function Register SCON, while the stop bit is not saved. The baud rate is programmable to either $\frac{1}{16}$ or $\frac{1}{32}$ of the CPU clock frequency, as determined by the SMOD1 bit in PCON. The SMOD1 bit controls the Timer 1 output rate available to the UART.

8.19.4 Mode 3

11 bits are transmitted (through TXD) or received (through RXD): a start bit (logic 0), 8 data bits (LSB first), a programmable 9th data bit, and a stop bit (logic 1). In fact, Mode 3 is the same as Mode 2 in all respects except baud rate. The baud rate in Mode 3 is variable and is determined by the Timer 1 overflow rate or the Baud Rate Generator (described in [Section 8.19.5 “Baud rate generator and selection”](#)).

8.19.5 Baud rate generator and selection

Each enhanced UART has an independent Baud Rate Generator. The baud rate is determined by a baud-rate preprogrammed into the BRGR1 and BRGR0 SFRs which together form a 16-bit baud rate divisor value that works in a similar manner as Timer 1 but is much more accurate. If the baud rate generator is used, Timer 1 can be used for other timing functions.

The UART can use either Timer 1 or its baud rate generator output (see Figure 13). Note that Timer T1 is further divided by 2 if the SMOD1 bit (PCON.7) is cleared. The independent Baud Rate Generator uses OSCCLK.

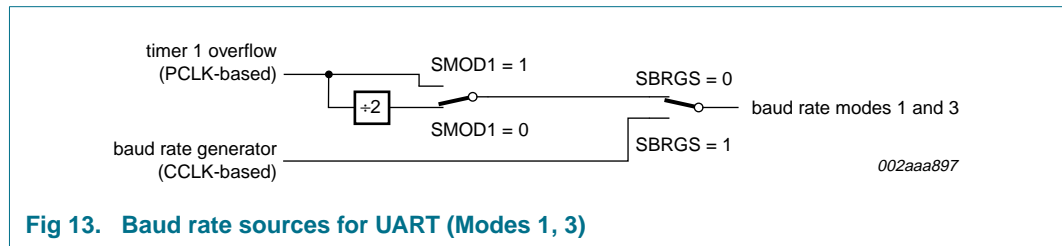

Fig 13. Baud rate sources for UART (Modes 1, 3)

8.19.6 Framing error

Framing error is reported in the status register (SSTAT). In addition, if SMOD0 (PCON.6) is '1', framing errors can be made available in SCON.7 respectively. If SMOD0 is '0', SCON.7 is SM0. It is recommended that SM0 and SM1 (SCON [7:6]) are set up when SMOD0 is '0'.

8.19.7 Break detect

Break detect is reported in the status register (SSTAT). A break is detected when 11 consecutive bits are sensed LOW. The break detect can be used to reset the device and force the device into ISP mode.

8.19.8 Double buffering

The UART has a transmit double buffer that allows buffering of the next character to be written to SnBUF while the first character is being transmitted. Double buffering allows transmission of a string of characters with only one stop bit between any two characters, as long as the next character is written between the start bit and the stop bit of the previous character.

Double buffering can be disabled. If disabled (DBMOD, i.e., SSTAT.7 = 0), the UART is compatible with the conventional 80C51 UART. If enabled, the UART allows writing to SBUF while the previous data is being shifted out. Double buffering is only allowed in Modes 1, 2 and 3. When operated in Mode 0, double buffering must be disabled (DBMOD = 0).

8.19.9 Transmit interrupts with double buffering enabled (Modes 1, 2 and 3)

Unlike the conventional UART, in double buffering mode, the TI interrupt is generated when the double buffer is ready to receive new data.

8.19.10 The 9th bit (bit 8) in double buffering (Modes 1, 2 and 3)

If double buffering is disabled TB8 can be written before or after SBUF is written, as long as TB8 is updated some time before that bit is shifted out. TB8 must not be changed until the bit is shifted out, as indicated by the TI interrupt.

If double buffering is enabled, TB **must** be updated before SBUF is written, as TB8 will be double-buffered together with SBUF data.

8.20 I²C-bus serial interface

I²C-bus uses two wires (SDA and SCL) to transfer information between devices connected to the bus, and it has the following features:

- Bidirectional data transfer between masters and slaves
- Multi master bus (no central master)
- Arbitration between simultaneously transmitting masters without corruption of serial data on the bus
- Serial clock synchronization allows devices with different bit rates to communicate via one serial bus
- Serial clock synchronization can be used as a handshake mechanism to suspend and resume serial transfer
- The I²C-bus may be used for test and diagnostic purposes.

A typical I²C-bus configuration is shown in [Figure 14](#). The P89LPC915/916/917 device provides a byte-oriented I²C-bus interface that supports data transfers up to 400 kHz.

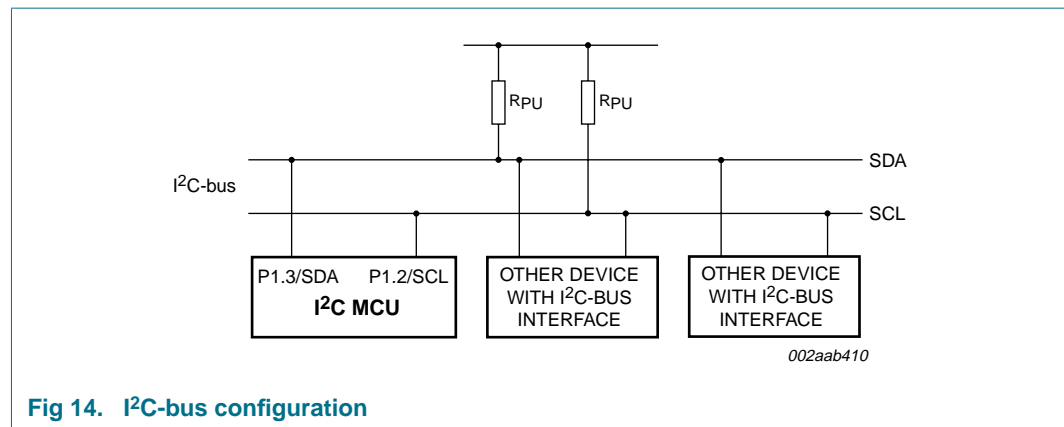

Fig 14. I²C-bus configuration

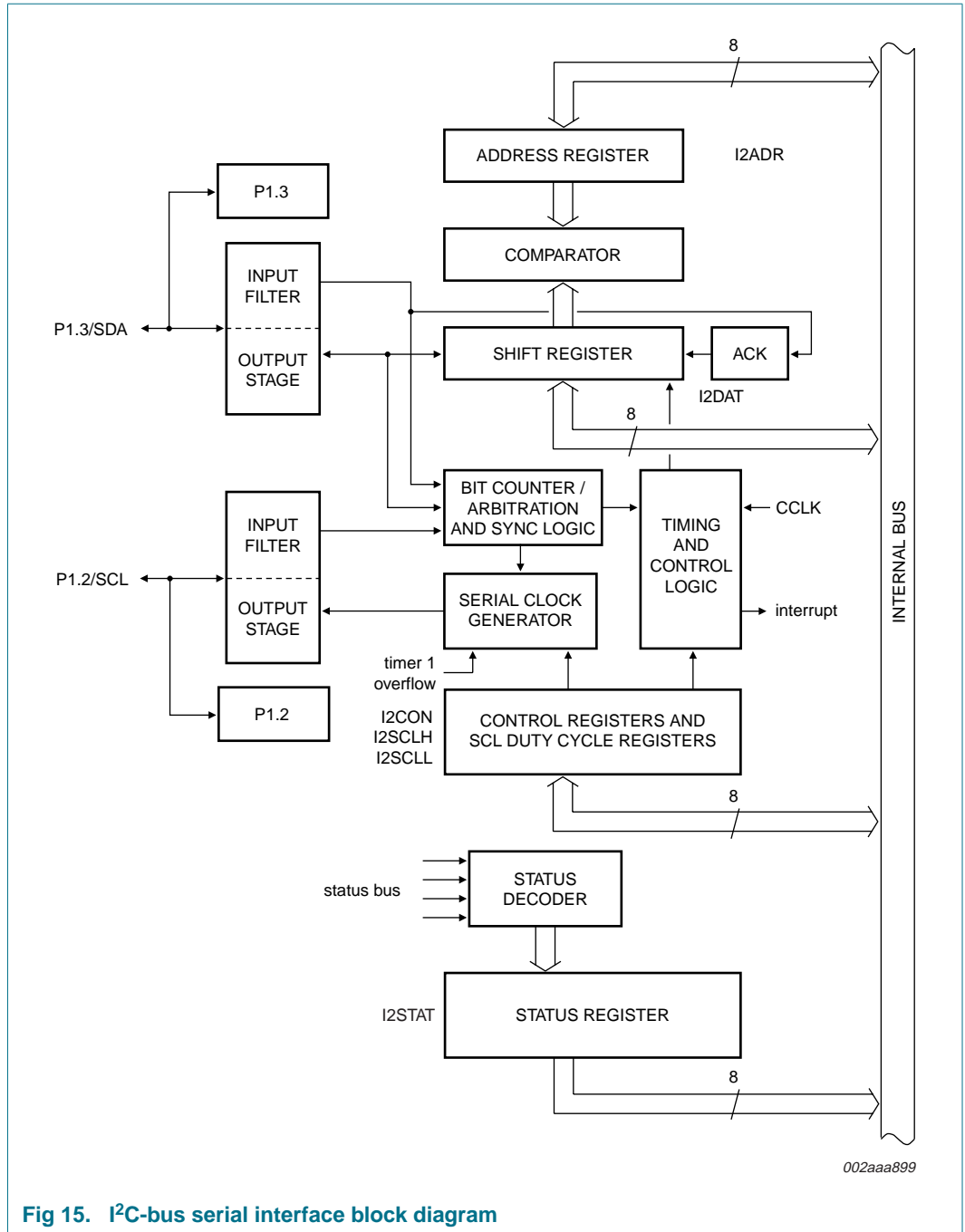

Fig 15. I²C-bus serial interface block diagram

8.21 SPI

The P89LPC916 provides another high-speed serial communication interface—the SPI interface. SPI is a full-duplex, high-speed, synchronous communication bus with two operation modes: Master mode and Slave mode. Up to 4.5 Mbit/s can be supported in Master mode or up to 3 Mbit/s in Slave mode. It has a Transfer Completion Flag and Write Collision Flag Protection.

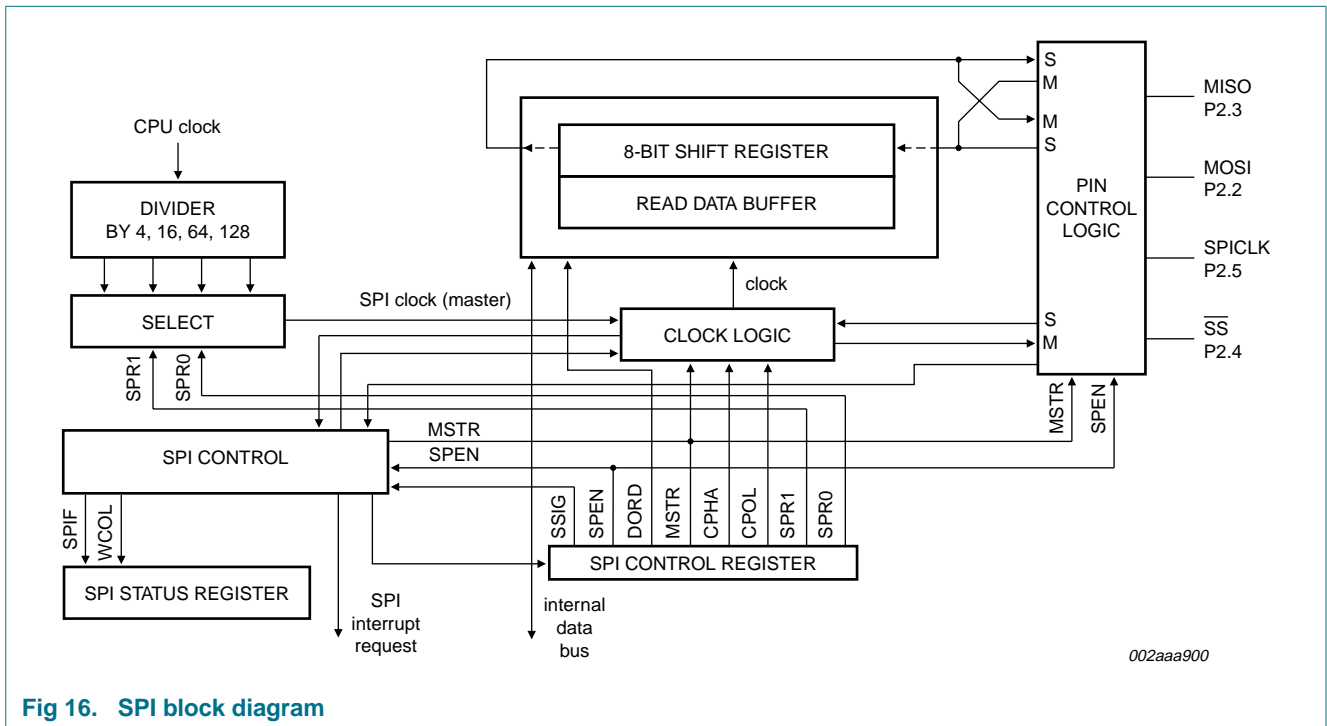

Fig 16. SPI block diagram

The SPI interface has four pins: SPICLK, MOSI, MISO and \overline{SS} :

- SPICLK, MOSI and MISO are typically tied together between two or more SPI devices. Data flows from master to slave on MOSI (Master Out Slave In) pin and flows from slave to master on MISO (Master In Slave Out) pin. The SPICLK signal is output in the master mode and is input in the slave mode. If the SPI system is disabled, i.e., SPEN (SPCTL.6) = 0 (reset value), these pins are configured for port functions.
- \overline{SS} is the optional slave select pin. In a typical configuration, an SPI master asserts one of its port pins to select one SPI device as the current slave. An SPI slave device uses its \overline{SS} pin to determine whether it is selected.

Typical connections are shown in [Figure 17](#) through [Figure 19](#).

8.21.1 Typical SPI configurations

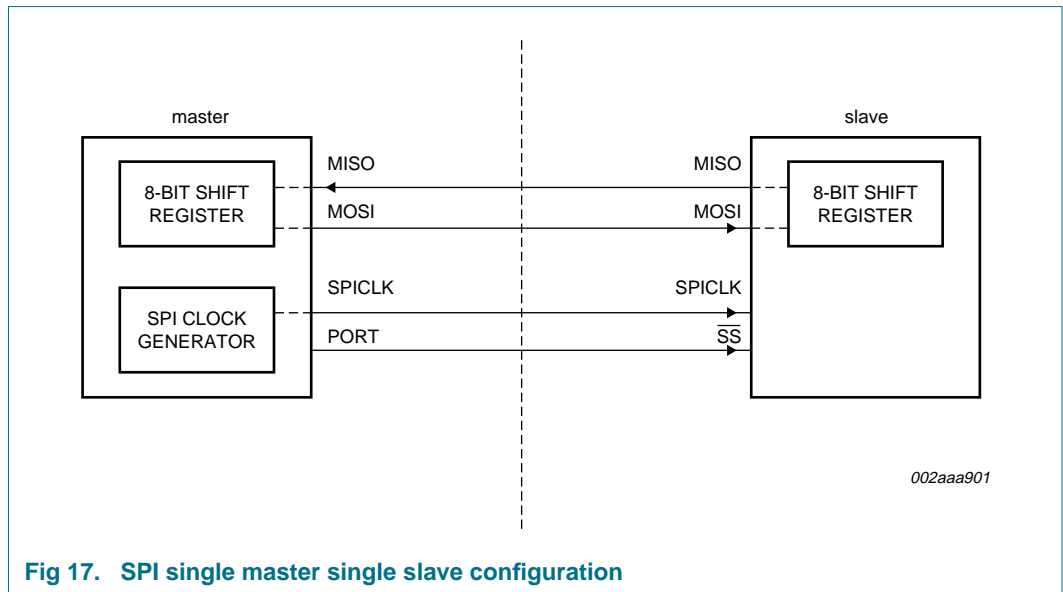

Fig 17. SPI single master single slave configuration

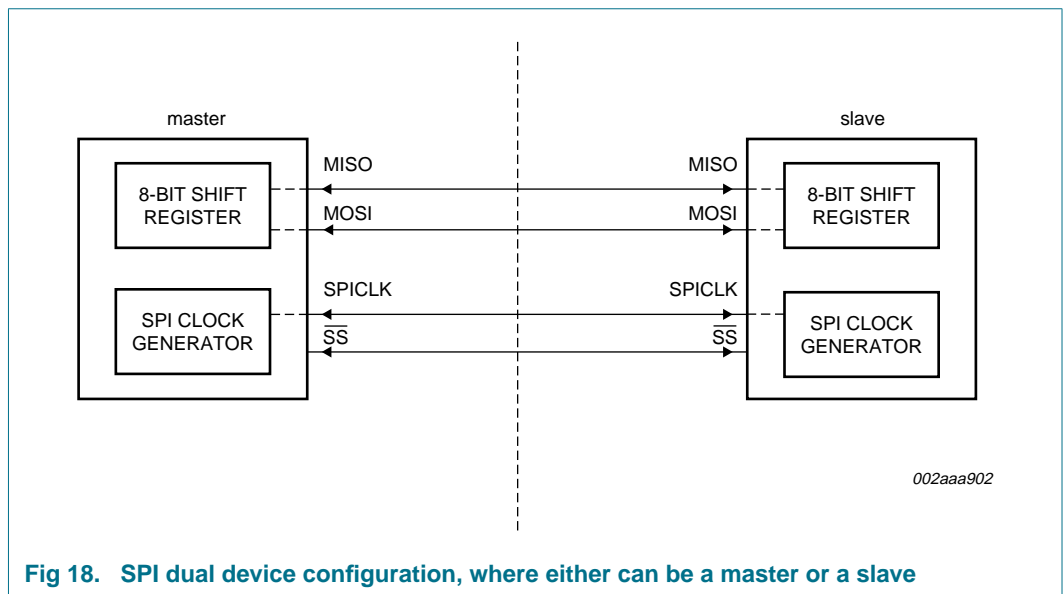

Fig 18. SPI dual device configuration, where either can be a master or a slave

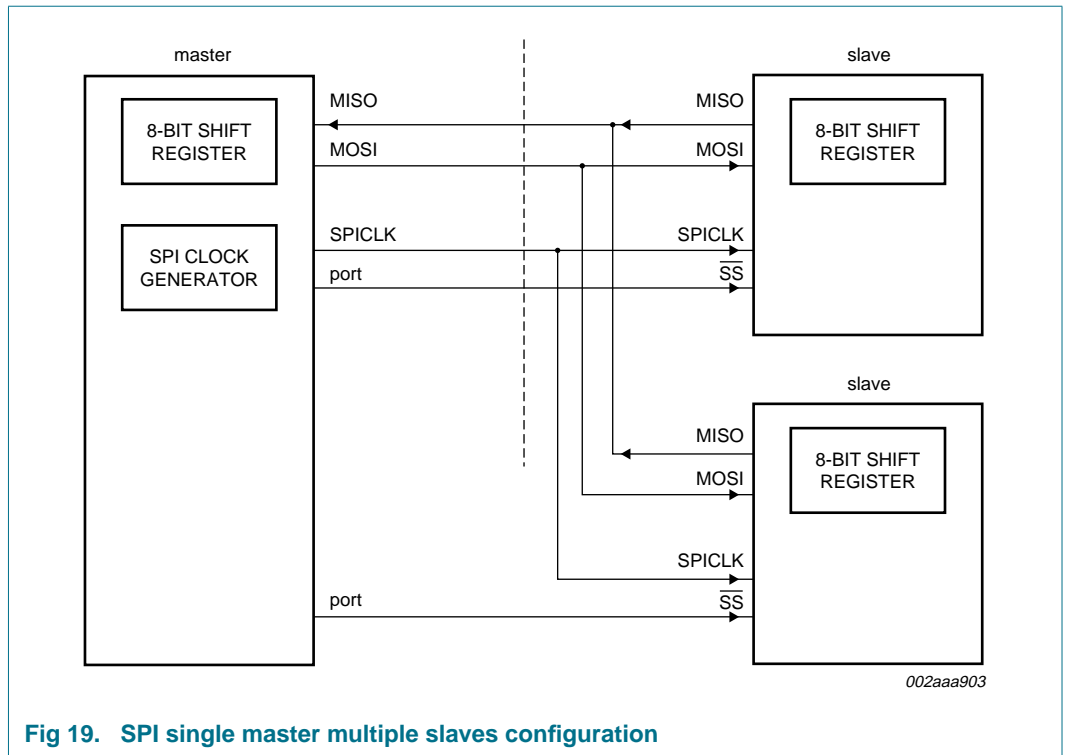

Fig 19. SPI single master multiple slaves configuration

8.22 Analog comparators

Two analog comparators are provided on the P89LPC915/916/917. Input and output options allow use of the comparators in a number of different configurations. Comparator operation is such that the output is a logical one when the positive input is greater than the negative input (selectable from a pin or an internal reference voltage). Otherwise the output is a zero. Each comparator may be configured to cause an interrupt when the output value changes. Comparator 1 may be output to a port pin.

The overall connections to both comparators are shown in [Figure 20](#). The comparators function to $V_{DD} = 2.4\text{ V}$.

When each comparator is first enabled, the comparator output and interrupt flag are not guaranteed to be stable for 10 microseconds. The corresponding comparator interrupt should not be enabled during that time, and the comparator interrupt flag must be cleared before the interrupt is enabled in order to prevent an immediate interrupt service.

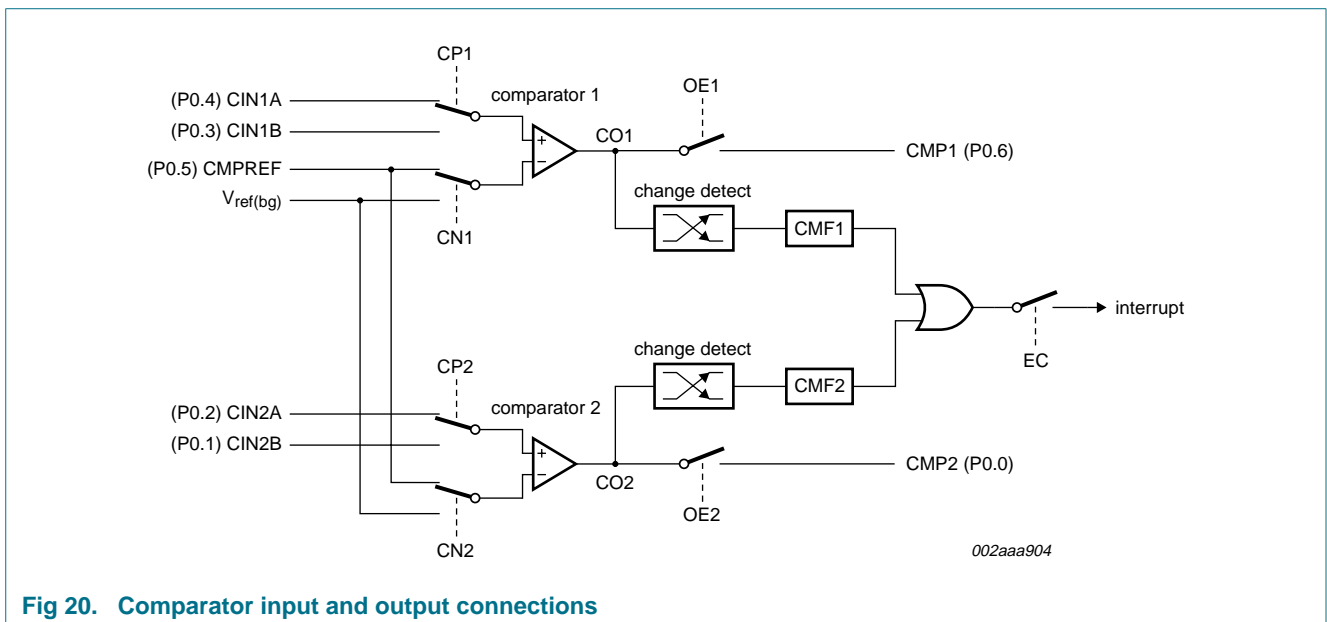

Fig 20. Comparator input and output connections

8.22.1 Internal reference voltage

An internal reference voltage generator may supply a default reference when a single comparator input pin is used. The value of the internal reference voltage, referred to as $V_{ref(bg)}$, is $1.23\text{ V} \pm 10\%$.

8.22.2 Comparator interrupt

Each comparator has an interrupt flag contained in its configuration register. This flag is set whenever the comparator output changes state. The flag may be polled by software or may be used to generate an interrupt. The two comparators use one common interrupt vector. If both comparators enable interrupts, after entering the interrupt service routine, the user needs to read the flags to determine which comparator caused the interrupt.

8.22.3 Comparators and power reduction modes

Either or both comparators may remain enabled when Power-down or Idle mode is activated, but both comparators are disabled automatically in Total Power-down mode.

If a comparator interrupt is enabled (except in Total Power-down mode), a change of the comparator output state will generate an interrupt and wake-up the processor. If the comparator output to a pin is enabled, the pin should be configured in the push-pull mode in order to obtain fast switching times while in Power-down mode. The reason is that with the **oscillator** stopped, the temporary strong pull-up that normally occurs during switching on a quasi-bidirectional port pin does not take place.

Comparators consume power in Power-down and Idle modes, as well as in the normal operating mode. This fact should be taken into account when system power consumption is an issue. To minimize power consumption, the user can disable the comparators via PCONA.5, or put the device in Total Power-down mode.

8.23 KBI

The Keypad Interrupt function is intended primarily to allow a single interrupt to be generated when Port 0 is equal to or not equal to a certain pattern. This function can be used for bus address recognition or keypad recognition. The user can configure the port via SFRs for different tasks.

The Keypad Interrupt Mask Register (KBMASK) is used to define which input pins connected to Port 0 can trigger the interrupt. The Keypad Pattern Register (KBPATN) is used to define a pattern that is compared to the value of Port 0. The Keypad Interrupt Flag (KBIF) in the Keypad Interrupt Control Register (KBCON) is set when the condition is matched while the Keypad Interrupt function is active. An interrupt will be generated if enabled. The PATN_SEL bit in the Keypad Interrupt Control Register (KBCON) is used to define equal or not-equal for the comparison.

In order to use the Keypad Interrupt as an original KBI function like in 87LPC76x series, the user needs to set KBPATN = 0FFH and PATN_SEL = 1 (not equal), then any key connected to Port 0 which is enabled by the KBMASK register will cause the hardware to set KBIF and generate an interrupt if it has been enabled. The interrupt may be used to wake-up the CPU from Idle or Power-down modes. This feature is particularly useful in handheld, battery-powered systems that need to carefully manage power consumption yet also need to be convenient to use.

In order to set the flag and cause an interrupt, the pattern on Port 0 must be held longer than six CCLKs.

8.24 Watchdog timer

The watchdog timer causes a system reset when it underflows as a result of a failure to feed the timer prior to the timer reaching its terminal count. It consists of a programmable 12-bit prescaler, and an 8-bit down-counter. The down-counter is decremented by a tap taken from the prescaler. The clock source for the prescaler is either the PCLK or the nominal 400 kHz watchdog oscillator. The watchdog timer can only be reset by a power-on reset. When the watchdog feature is disabled, it can be used as an interval timer and may generate an interrupt. Figure 21 shows the watchdog timer in Watchdog mode. Feeding the watchdog requires a two-byte sequence. If PCLK is selected as the watchdog clock and the CPU is powered down, the watchdog is disabled. The watchdog timer has a time-out period that ranges from a few μ s to a few seconds. Please refer to the P89LPC915/916/917 *User's Manual* for more details.

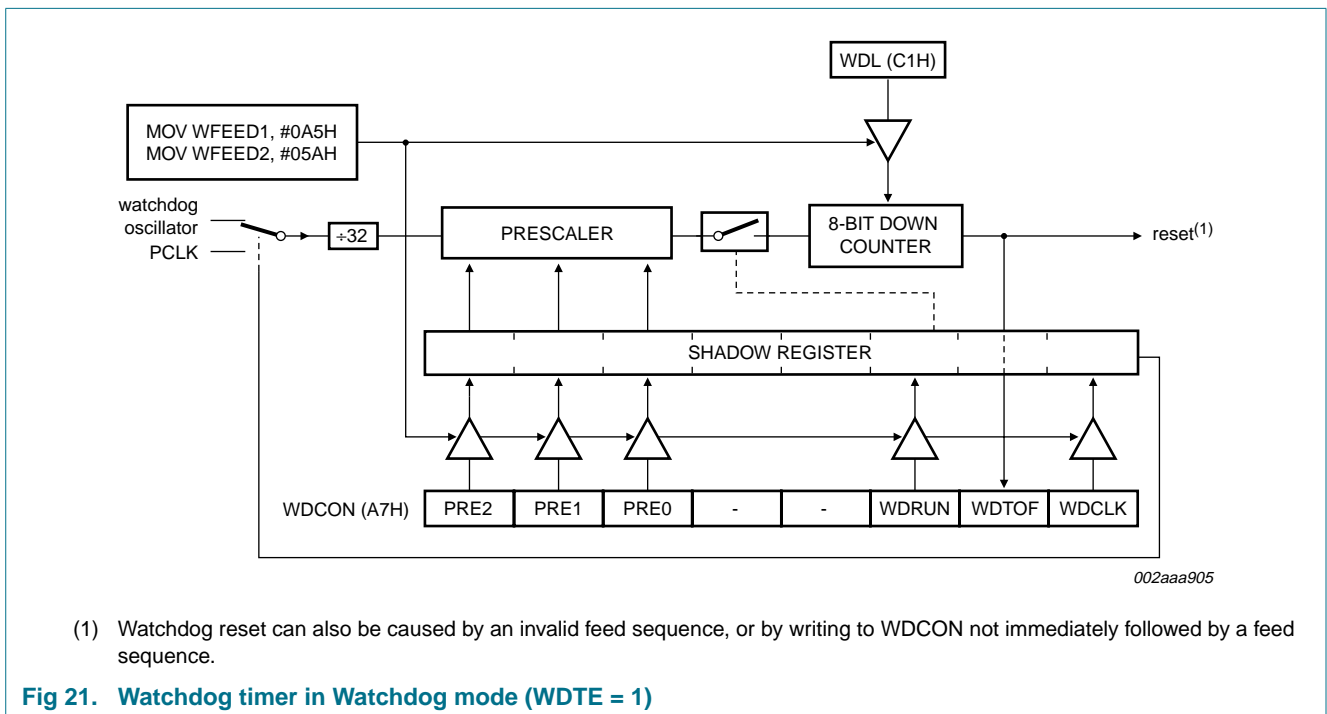

8.25 Additional features

8.25.1 Software reset

The SRST bit in AUXR1 gives software the opportunity to reset the processor completely, as if an external reset or watchdog reset had occurred. Care should be taken when writing to AUXR1 to avoid accidental software resets.

8.25.2 Dual data pointers

The dual Data Pointers (DPTR) provides two different Data Pointers to specify the address used with certain instructions. The DPS bit in the AUXR1 register selects one of the two Data Pointers. Bit 2 of AUXR1 is permanently wired as a logic 0 so that the DPS bit may be toggled (thereby switching Data Pointers) simply by incrementing the AUXR1 register, without the possibility of inadvertently altering other bits in the register.

8.26 Flash program memory

8.26.1 General description

The P89LPC915/916/917 flash memory provides in-circuit electrical erasure and programming. The flash can be erased, read, and written as bytes. The Sector and Page Erase functions can erase any flash sector (256 bytes) or page (16 bytes). The Chip Erase operation will erase the entire program memory. ICP using standard commercial programmers is available. In addition, IAP and byte-erase allows code memory to be used for non-volatile data storage. On-chip erase and write timing generation contribute to a user-friendly programming interface. The P89LPC915/916/917 flash reliably stores memory contents even after 100,000 erase and program cycles. The cell is designed to optimize the erase and programming mechanisms. The P89LPC915/916/917 uses V_{DD} as the supply voltage to perform the Program/Erase algorithms.

8.26.2 Features

- Programming and erase over the full operating voltage range.
- Byte erase allows code memory to be used for data storage.
- Read/Programming/Erase using ICP.
- Boot vector allows user-provided flash loader code to reside anywhere in the flash memory space, providing flexibility to the user.
- Any flash program/erase operation in 2 ms.
- Programming with industry-standard commercial programmers.
- Programmable security for the code in the flash for each sector.
- 100,000 typical erase/program cycles for each byte.
- 10 year minimum data retention.

8.26.3 Flash organization

The program memory consists of eight 256-byte sectors on the P89LPC915/916/917 devices. Each sector can be further divided into 16-byte pages. In addition to sector erase, page erase, and byte erase, a 16-byte page register is included which allows from 1 to 16 bytes of a given page to be programmed at the same time, substantially reducing overall programming time.

8.26.4 Using flash as data storage

The flash code memory array of this device supports individual byte erasing and programming. Any byte in the code memory array may be read using the MOV_C instruction, provided that the sector containing the byte has not been secured (a MOV_C instruction is not allowed to read code memory contents of a secured sector). Thus any byte in a non-secured sector may be used for non-volatile data storage.

8.26.5 Flash programming and erasing

Two different methods of erasing or programming of the flash are available. The flash may be programmed or erased in the end-user application (IAP-Lite) under control of the application's firmware. Another option is to use the ICP mechanism. This ICP system provides for programming through a serial clock/serial data interface. This device does not provide for direct verification of code memory contents. Instead, this device provides a 32-bit CRC result on either a sector or the entire user code space.

8.26.6 ICP

ICP is performed without removing the microcontroller from the system. The ICP facility consists of internal hardware resources to facilitate remote programming of the P89LPC915/916/917 through a two-wire serial interface. The NXP ICP facility has made in-circuit programming in an embedded application—using commercially available programmers—possible with a minimum of additional expense in components and circuit board area. The ICP function uses five pins. Only a small connector needs to be available to interface your application to a commercial programmer in order to use this feature. Additional details may be found in the P89LPC915/916/917 *User's Manual*.

8.26.7 IAP-Lite

IAP-Lite is performed in the application under the control of the microcontroller's firmware. The IAP facility consists of internal hardware resources to facilitate programming and erasing. The IAP-Lite operations are accomplished through the use of four SFRs consisting of a control/status register, a data register, and two address registers. Additional details may be found in the P89LPC915/916/917 *User's Manual*.

8.26.8 Power-on reset code execution

The P89LPC915/916/917 contains two special flash elements: the Boot Vector and the Boot Status bit. Following reset, the P89LPC915/916/917 examines the contents of the Boot Status bit. If the Boot Status bit is set to zero, power-up execution starts at location 0000H, which is the normal start address of the user's application code. When the Boot Status bit is set to a value other than zero, the contents of the Boot Vector are used as the high byte of the execution address and the low byte is set to 00H.

[Table 13](#) shows the factory default Boot Vector setting for this device. While these devices do not contain a factory bootloader, the Boot Vector and Status bit do provide a mechanism for an alternate code execution at reset.

Table 13. Default boot vector and Status bit values

Device	Default boot vector	Default Status bit
P89LPC915	00H	0
P89LPC916	00H	0
P89LPC917	00H	0

8.26.9 Hardware activation of the alternate code

The alternate code execution address can be forced during a power-on sequence (see the P89LPC915/916/917 *User's Manual* for specific information). This has the same effect as having a non-zero status byte. This allows an application to be built that will normally execute user code starting at address 0000H but can be manually forced into executing from an alternated address using the Boot Vector. After programming the flash, the status byte should be programmed to zero in order to allow execution of the user's application code beginning at address 0000H.

8.27 User configuration bytes

Some user-configurable features of the P89LPC915/916/917 must be defined at power-up and therefore cannot be set by the program after start of execution. These features are configured through the use of the flash byte UCFG1. Please see the P89LPC915/916/917 *User's Manual* for additional details.

8.28 User sector security bytes

There are eight User Sector Security Bytes on the P89LPC915/916/917. Each byte corresponds to one sector. Please see the P89LPC915/916/917 *User's Manual* for additional details.

9. A/D converter

9.1 General description

The P89LPC915/916/917 devices have a single 8-bit, 4-channel multiplexed analog-to-digital converter with a DAC module. A block diagram of the A/D converter is shown in [Figure 22](#). The A/D consists of a 4-input multiplexer which feeds a sample-and-hold circuit providing an input signal to one of two comparator inputs. The control logic in combination with the SAR drives a digital-to-analog converter which provides the other input to the comparator. The output of the comparator is fed to the SAR.

9.2 Features

- Single 8-bit, 4-channel multiplexed input, successive approximation A/D converter.
- Four A/D result registers.
- Six operating modes:
 - ◆ Fixed channel, single conversion mode.
 - ◆ Fixed channel, continuous conversion mode.
 - ◆ Auto scan, single conversion mode.
 - ◆ Auto scan, continuous conversion mode.
 - ◆ Dual channel, continuous conversion mode.
 - ◆ Single step mode.
- Three conversion start modes:
 - ◆ Timer triggered start.
 - ◆ Start immediately.
 - ◆ Edge triggered.
- 8-bit conversion time of $\geq 3.9 \mu\text{s}$ at an A/D clock of 3.3 MHz.
- Interrupt or polled operation.
- Boundary limits interrupt.
- DAC output to a port pin with high output impedance.
- Clock divider.
- Power-down mode.

9.3 Block diagram

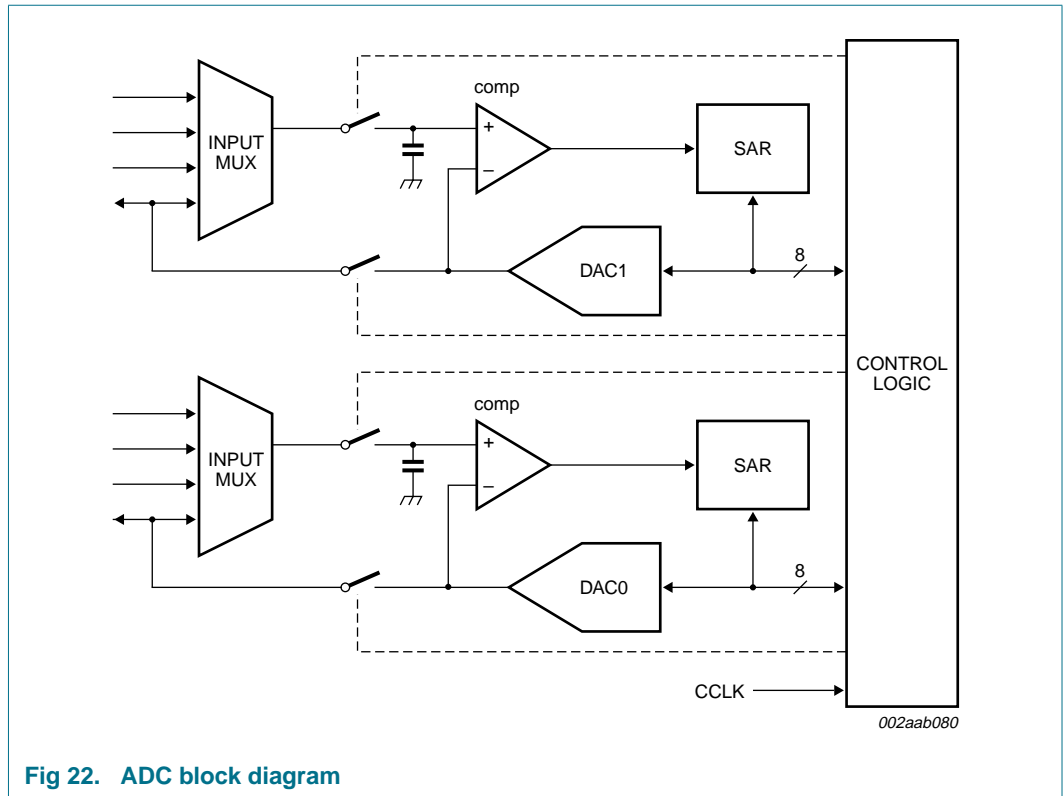

Fig 22. ADC block diagram

9.4 A/D operating modes

9.4.1 Fixed channel, single conversion mode

A single input channel can be selected for conversion. A single conversion will be performed and the result placed in the result register which corresponds to the selected input channel. An interrupt, if enabled, will be generated after the conversion completes.

9.4.2 Fixed channel, continuous conversion mode

A single input channel can be selected for continuous conversion. The results of the conversions will be sequentially placed in the four result registers. An interrupt, if enabled, will be generated after every four conversions. Additional conversion results will again cycle through the four result registers, overwriting the previous results. Continuous conversions continue until terminated by the user.

9.4.3 Auto scan, single conversion mode

Any combination of the four input channels can be selected for conversion. A single conversion of each selected input will be performed and the result placed in the result register which corresponds to the selected input channel. An interrupt, if enabled, will be generated after all selected channels have been converted. If only a single channel is selected this is equivalent to single channel, single conversion mode.

9.4.4 Auto scan, continuous conversion mode

Any combination of the four input channels can be selected for conversion. A conversion of each selected input will be performed and the result placed in the result register which corresponds to the selected input channel. An interrupt, if enabled, will be generated after all selected channels have been converted. The process will repeat starting with the first selected channel. Additional conversion results will again cycle through the four result registers, overwriting the previous results. Continuous conversions continue until terminated by the user.

9.4.5 Dual channel, continuous conversion mode

This is a variation of the auto scan continuous conversion mode where conversion occurs on two user-selectable inputs. The result of the conversion of the first channel is placed in result register, AD1DAT0. The result of the conversion of the second channel is placed in result register, AD1DAT1. The first channel is again converted and its result stored in AD1DAT2. The second channel is again converted and its result placed in AD1DAT3. An interrupt is generated, if enabled, after every set of four conversions (two conversions per channel).

9.4.6 Single step mode

This special mode allows 'single-stepping' in an auto scan conversion mode. Any combination of the four input channels can be selected for conversion. After each channel is converted, an interrupt is generated, if enabled, and the A/D waits for the next start condition. May be used with any of the start modes.

9.5 Conversion start modes

9.5.1 Timer triggered start

An A/D conversion is started by the overflow of Timer 0. Once a conversion has started, additional Timer 0 triggers are ignored until the conversion has completed. The Timer triggered start mode is available in all A/D operating modes.

9.5.2 Start immediately

Programming this mode immediately starts a conversion. This start mode is available in all A/D operating modes.

9.5.3 Edge triggered

An A/D conversion is started by rising or falling edge of P1.4. Once a conversion has started, additional edge triggers are ignored until the conversion has completed. The edge triggered start mode is available in all A/D operating modes.

9.6 Boundary limits interrupt

The A/D converter has both a high and low boundary limit register. After the four MSBs have been converted, these four bits are compared with the four MSBs of the boundary high and low registers. If the four MSBs of the conversion are outside the limit an interrupt will be generated, if enabled. If the conversion result is within the limits, the boundary limits will again be compared after all 8 bits have been converted. An interrupt will be generated, if enabled, if the result is outside the boundary limits. The boundary limit may be disabled by clearing the boundary limit interrupt enable.

9.7 DAC output to a port pin with high output impedance

The A/D converter's DAC block can be output to a port pin. In this mode, the AD1DAT3 register is used to hold the value fed to the DAC. After a value has been written to the DAC (written to AD1DAT3), the DAC output will appear on the channel 3 pin.

9.8 Clock divider

The A/D converter requires that its internal clock source be in the range of 500 kHz to 3.3 MHz to maintain accuracy. A programmable clock divider that divides the clock from 1 to 8 is provided for this purpose.

9.9 Power-down and Idle mode

In Idle mode the A/D converter, if enabled, will continue to function and can cause the device to exit Idle mode when the conversion is completed if the A/D interrupt is enabled. In Power-down mode or Total Power-down mode, the A/D does not function. If the A/D is enabled, it will consume power. Power can be reduced by disabling the A/D.

10. Limiting values

Table 14. Limiting values

In accordance with the Absolute Maximum Rating System (IEC 60134).^[1]

Symbol	Parameter	Conditions	Min	Max	Unit
$T_{amb(bias)}$	operating bias ambient temperature		-55	+125	°C
T_{stg}	storage temperature range		-65	+150	°C
$I_{OH(I/O)}$	HIGH-level output current per I/O pin		-	8	mA
$I_{OL(I/O)}$	LOW-level output current per I/O pin		-	20	mA
$I_{I/O(tot)(max)}$	maximum total I/O current		-	120	mA
V_n	voltage on any pin (except V_{SS})	with respect to V_{DD}	-	3.5	V
$P_{tot(pack)}$	total power dissipation per package	based on package heat transfer, not device power consumption	-	1.5	W

[1] The following applies to [Table 14](#):

- a) This product includes circuitry specifically designed for the protection of its internal devices from the damaging effects of excessive static charge. Nonetheless, it is suggested that conventional precautions be taken to avoid applying greater than the rated maximum.
- b) Parameters are valid over ambient temperature range unless otherwise specified. All voltages are with respect to V_{SS} unless otherwise noted.

11. Static characteristics

Table 15. Static characteristics

$V_{DD} = 2.4\text{ V to }3.6\text{ V}$ unless otherwise specified.

$T_{amb} = -40\text{ °C to }+85\text{ °C}$, or $-40\text{ °C to }+125\text{ °C}$ (see [Table 3 on page 3](#)), unless otherwise specified.

Symbol	Parameter	Conditions	Min	Typ ^[1]	Max	Unit
$I_{DD(oper)}$	operating supply current	$V_{DD} = 3.6\text{ V}$; $f_{osc} = 12\text{ MHz}$	[2] -	7	13	mA
		$V_{DD} = 3.6\text{ V}$; $f_{osc} = 18\text{ MHz}$	[2] -	11	16	mA
$I_{DD(idle)}$	Idle mode supply current	$V_{DD} = 3.6\text{ V}$; $f_{osc} = 12\text{ MHz}$	[2] -	3.6	4.8	mA
		$V_{DD} = 3.6\text{ V}$; $f_{osc} = 18\text{ MHz}$	[2] -	4	6	mA
$I_{DD(pd)}$	power supply current, power-down mode, voltage comparators powered-down	$V_{DD} = 3.6\text{ V}$, industrial	[2] -	45	70	μA
		$V_{DD} = 3.6\text{ V}$, extended	[2]	-	150	μA
$I_{DD(tpd)}$	total Power-down mode supply current	$V_{DD} = 3.6\text{ V}$, industrial	[3] -	<0.1	5	μA
		$V_{DD} = 3.6\text{ V}$, extended	[3] -	-	50	μA
$(dV/dt)_r$	rise rate	of V_{DD}	-	-	2	$\text{mV}/\mu\text{s}$
$(dV/dt)_f$	fall rate	of V_{DD}	-	-	50	$\text{mV}/\mu\text{s}$
V_{POR}	power-on reset voltage		-	-	0.2	V
V_{DDR}	data retention voltage		1.5	-	-	V
$V_{th(HL)}$	HIGH-LOW threshold voltage	except SCL, SDA	$0.22V_{DD}$	$0.4V_{DD}$	-	V
V_{IL}	LOW-level input voltage	SCL, SDA only	-0.5	-	$0.3V_{DD}$	V
$V_{th(LH)}$	LOW-HIGH threshold voltage	except SCL, SDA	-	$0.6V_{DD}$	$0.7V_{DD}$	V
V_{IH}	HIGH-level input voltage	SCL, SDA only	$0.7V_{DD}$	-	5.5	V
V_{hys}	hysteresis voltage	port 1	-	$0.2V_{DD}$	-	V
V_{OL}	LOW-level output voltage	$I_{OL} = 20\text{ mA}$; all ports except SCL, SDA	[4] -	0.6	1.0	V
		$I_{OL} = 10\text{ mA}$; all ports except SCL, SDA	-	0.2	0.3	V
		$I_{OL} = 3.2\text{ mA}$; all ports except SCL, SDA	-	0.2	0.3	V
V_{OH}	HIGH-level output voltage	$I_{OH} = -8\text{ mA}$; push-pull mode; all ports except SCL, SDA	$V_{DD} - 1$	-	-	V
		$I_{OH} = -3.2\text{ mA}$; push-pull mode; all ports except SCL, SDA	$V_{DD} - 0.7$	$V_{DD} - 0.4$	-	V
		$I_{OH} = -20\text{ }\mu\text{A}$; quasi-bidirectional mode; all ports except SCL, SDA	$V_{DD} - 0.3$	$V_{DD} - 0.2$	-	V
V_{xtal}	crystal voltage	voltage on XTAL1, XTAL2 pins with respect to V_{SS}	-0.5	-	+4.0	V
V_n	voltage on any pin (except XTAL1, XTAL2, V_{DD})	with respect to V_{SS}	[5] -0.5	-	+5.5	V
C_{iss}	input capacitance		[6] -	-	15	pF
I_{IL}	logical 0 input current	$V_I = 0.4\text{ V}$	[7] -	-	-80	μA

Table 15. Static characteristics ...continued

$V_{DD} = 2.4\text{ V to }3.6\text{ V}$ unless otherwise specified.

$T_{amb} = -40\text{ }^{\circ}\text{C to }+85\text{ }^{\circ}\text{C}$, or $-40\text{ }^{\circ}\text{C to }+125\text{ }^{\circ}\text{C}$ (see [Table 3 on page 3](#)), unless otherwise specified.

Symbol	Parameter	Conditions	Min	Typ ^[1]	Max	Unit
I_{LI}	input leakage current	$V_I = V_{IL}, V_{IH}$ or $V_{th(HL)}$	[8] -	-	± 10	μA
I_{TL}	logical 1-to-0 transition current, all ports	$V_I = 1.5\text{ V}$ at $V_{DD} = 3.6\text{ V}$	[9] -30	-	-450	μA
$R_{RST(int)}$	internal pull-up resistance on pin RST		10	-	30	$\text{k}\Omega$
V_{bo}	brownout trip voltage	$2.4\text{ V} < V_{DD} < 3.6\text{ V}$; with $BOV = 1, BOPD = 0$	2.40	-	2.70	V
$V_{ref(bg)}$	band gap reference voltage		1.11	1.23	1.34	V
TC_{bg}	band gap temperature coefficient		-	10	20	$\text{ppm}/^{\circ}\text{C}$

- [1] Typical ratings are not guaranteed. The values listed are at room temperature, 3 V.
- [2] The $I_{DD(oper)}$, $I_{DD(idle)}$, and $I_{DD(pd)}$ specifications are measured using an external clock with the following functions disabled: comparators, real-time clock, and watchdog timer.
- [3] The $I_{DD(tpd)}$ specification is measured using an external clock with the following functions disabled: comparators, real-time clock, brownout detect, and watchdog timer.
- [4] See [Section 10 "Limiting values"](#) for steady state (non-transient) limits on I_{OL} or I_{OH} . If I_{OL}/I_{OH} exceeds the test condition, V_{OL}/V_{OH} may exceed the related specification.
- [5] This specification can be applied to pins which have A/D input or analog comparator input functions when the pin is not being used for those analog functions. When the pin is being used as an analog input pin, the maximum voltage on the pin must be limited to 4.0 V with respect to V_{SS} .
- [6] Pin capacitance is characterized but not tested.
- [7] Measured with port in quasi-bidirectional mode.
- [8] Measured with port in high-impedance mode.
- [9] Port pins source a transition current when used in quasi-bidirectional mode and externally driven from logic 1 to logic 0. This current is highest when V_I is approximately 2 V.

12. Dynamic characteristics

Table 16. Dynamic characteristics (12 MHz)

$V_{DD} = 2.4\text{ V to }3.6\text{ V}$ unless otherwise specified.

$T_{amb} = -40\text{ }^{\circ}\text{C to }+85\text{ }^{\circ}\text{C}$, or $-40\text{ }^{\circ}\text{C to }+125\text{ }^{\circ}\text{C}$ (see [Table 3 on page 3](#)), unless otherwise specified.^{[1][2]}

Symbol	Parameter	Conditions	Variable clock		$f_{osc} = 12\text{ MHz}$		Unit
			Min	Max	Min	Max	
$f_{osc(RC)}$	internal RC oscillator frequency	industrial	7.189	7.557	7.189	7.557	MHz
		extended	7.004	7.741	7.004	7.741	MHz
$f_{osc(WD)}$	internal watchdog oscillator frequency		320	520	320	520	kHz
f_{CLKLP}	low power select clock frequency		0	8	-	-	MHz

Glitch filter

t_{gr}	glitch rejection time	P1.5/ $\overline{\text{RST}}$ pin	-	50	-	50	ns
		any pin except P1.5/ $\overline{\text{RST}}$	-	15	-	15	ns
t_{sa}	signal acceptance time	P1.5/ $\overline{\text{RST}}$ pin	125	-	125	-	ns
		any pin except P1.5/ $\overline{\text{RST}}$	50	-	50	-	ns

External clock

f_{osc}	oscillator frequency		0	12	-	-	MHz
$T_{cy(clk)}$	clock cycle time	see Figure 28	83	-	-	-	ns
t_{CHCX}	clock HIGH time	see Figure 28	33	$T_{cy(CLK)} - t_{CLCX}$	33	-	ns
t_{CLCX}	clock LOW time	see Figure 28	33	$T_{cy(CLK)} - t_{CHCX}$	33	-	ns
t_{CLCH}	clock rise time	see Figure 28	-	8	-	8	ns
t_{CHCL}	clock fall time	see Figure 28	-	8	-	8	ns

Shift register (UART mode 0)

T_{XLXL}	serial port clock cycle time	see Figure 27	$16T_{cy(CLK)}$	-	1333	-	ns
t_{QVXH}	output data set-up to clock rising edge time	see Figure 27	$13T_{cy(CLK)}$	-	1083	-	ns
t_{XHQX}	output data hold after clock rising edge time	see Figure 27	-	$T_{cy(CLK)} + 20$	-	103	ns
t_{XHDX}	input data hold after clock rising edge time	see Figure 27	-	0	-	0	ns
t_{XHVD}	input data valid to clock rising edge time	see Figure 27	150	-	150	-	ns

SPI interface

f_{SPI}	SPI operating frequency						
	slave		0	$CCLK/6$	0	2.0	MHz
	master		-	$CCLK/4$	-	3.0	MHz
T_{SPICYC}	SPI cycle time	see Figure 23, 24, 25, 26					
	slave		$6/CCLK$	-	500	-	ns
	master		$4/CCLK$	-	333	-	ns

Table 16. Dynamic characteristics (12 MHz) ...continued $V_{DD} = 2.4\text{ V to }3.6\text{ V unless otherwise specified.}$ $T_{amb} = -40\text{ }^{\circ}\text{C to }+85\text{ }^{\circ}\text{C, or }-40\text{ }^{\circ}\text{C to }+125\text{ }^{\circ}\text{C (see Table 3 on page 3), unless otherwise specified.}[1][2]$

Symbol	Parameter	Conditions	Variable clock		$f_{osc} = 12\text{ MHz}$		Unit
			Min	Max	Min	Max	
t _{SPILEAD}	SPI enable lead time	see Figure 25, 26					
	slave		250	-	250	-	ns
t _{SPILAG}	SPI enable lag time	see Figure 25, 26					
	slave		250	-	250	-	ns
t _{SPICLKH}	SPICLK HIGH time	see Figure 23, 24, 25, 26					
	master		$\frac{2}{3}CCLK$	-	165	-	ns
	slave		$\frac{3}{3}CCLK$	-	250	-	ns
t _{SPICLKL}	SPICLK LOW time	see Figure 23, 24, 25, 26					
	master		$\frac{2}{3}CCLK$	-	165	-	ns
	slave		$\frac{3}{3}CCLK$	-	250	-	ns
t _{SPIDSU}	SPI data set-up time	see Figure 23, 24, 25, 26					
	master or slave		100	-	100	-	ns
t _{SPI DH}	SPI data hold time	see Figure 23, 24, 25, 26					
	master or slave		100	-	100	-	ns
t _{SPIA}	SPI access time	see Figure 25, 26					
	slave		0	120	0	120	ns
t _{SPI DIS}	SPI disable time	see Figure 25, 26					
	slave		0	240	-	240	ns
t _{SPI DV}	SPI enable to output data valid time	see Figure 23, 24, 25, 26					
	slave		-	240	-	240	ns
	master		-	167	-	167	ns
t _{SPI OH}	SPI output data hold time	see Figure 23, 24, 25, 26	0	-	0	-	ns
t _{SPI R}	SPI rise time	see Figure 23, 24, 25, 26					
	SPI outputs (SPICLK, MOSI, MISO)		-	100	-	100	ns
	SPI inputs (SPICLK, MOSI, MISO, \overline{SS})		-	2000	-	2000	ns
t _{SPI F}	SPI fall time	see Figure 23, 24, 25, 26					
	SPI outputs (SPICLK, MOSI, MISO)		-	100	-	100	ns
	SPI inputs (SPICLK, MOSI, MISO, \overline{SS})		-	2000	-	2000	ns

[1] Parameters are valid over ambient temperature range unless otherwise specified.

[2] Parts are tested to 2 MHz, but are guaranteed to operate down to 0 Hz.

Table 17. Dynamic characteristics (18 MHz)

$V_{DD} = 3.0\text{ V to }3.6\text{ V}$ unless otherwise specified.

$T_{amb} = -40\text{ °C to }+85\text{ °C}$, or $-40\text{ °C to }+125\text{ °C}$ (see [Table 3 on page 3](#)), unless otherwise specified.^{[1][2]}

Symbol	Parameter	Conditions	Variable clock		$f_{osc} = 18\text{ MHz}$		Unit
			Min	Max	Min	Max	
$f_{osc(RC)}$	internal RC oscillator frequency	industrial	7.189	7.557	7.189	7.557	MHz
		extended	7.004	7.741	7.004	7.741	MHz
$f_{osc(WD)}$	internal watchdog oscillator frequency		320	520	320	520	kHz
f_{CLKLP}	low power select clock frequency		0	8	-	-	MHz

Glitch filter

t_{gr}	glitch rejection time	P1.5/ \overline{RST} pin	-	50	-	50	ns
		any pin except P1.5/ \overline{RST}	-	15	-	15	ns
t_{sa}	signal acceptance time	P1.5/ \overline{RST} pin	125	-	125	-	ns
		any pin except P1.5/ \overline{RST}	50	-	50	-	ns

External clock

f_{osc}	oscillator frequency		0	18	-	-	MHz
$T_{cy(clk)}$	clock cycle time	see Figure 28	55	-	-	-	ns
t_{CHCX}	clock HIGH time	see Figure 28	22	$T_{cy(CLK)} - t_{CLCX}$	22	-	ns
t_{CLCX}	clock LOW time	see Figure 28	22	$T_{cy(CLK)} - t_{CHCX}$	22	-	ns
t_{CLCH}	clock rise time	see Figure 28	-	5	-	5	ns
t_{CHCL}	clock fall time	see Figure 28	-	5	-	5	ns

Shift register (UART mode 0)

T_{XLXL}	serial port clock cycle time	see Figure 27	$16T_{cy(CLK)}$	-	888	-	ns
t_{QVXH}	output data set-up to clock rising edge time	see Figure 27	$13T_{cy(CLK)}$	-	722	-	ns
t_{XHQX}	output data hold after clock rising edge time	see Figure 27	-	$T_{cy(CLK)} + 20$	-	75	ns
t_{XHDX}	input data hold after clock rising edge time	see Figure 27	-	0	-	0	ns
t_{XHDX}	input data valid to clock rising edge time	see Figure 27	150	-	150	-	ns

SPI interface

f_{SPI}	SPI operating frequency						
	slave		0	$CCLK/6$	0	3.0	MHz
	master		-	$CCLK/4$	-	4.5	MHz
T_{SPICYC}	SPI cycle time		see Figure 23, 24, 25, 26				
	slave		$6/CCLK$	-	333	-	ns
	master		$4/CCLK$	-	222	-	ns
$t_{SPILEAD}$	SPI enable lead time		see Figure 25, 26				
	slave		250	-	250	-	ns
t_{SPILAG}	SPI enable lag time	see Figure 25, 26	250	-	250	-	ns

Table 17. Dynamic characteristics (18 MHz) ...continued $V_{DD} = 3.0\text{ V to }3.6\text{ V}$ unless otherwise specified. $T_{amb} = -40\text{ }^{\circ}\text{C to }+85\text{ }^{\circ}\text{C}$, or $-40\text{ }^{\circ}\text{C to }+125\text{ }^{\circ}\text{C}$ (see [Table 3 on page 3](#)), unless otherwise specified.^{[1][2]}

Symbol	Parameter	Conditions	Variable clock		$f_{osc} = 18\text{ MHz}$		Unit
			Min	Max	Min	Max	
t _{SPICLKH}	SPICLK HIGH time	see Figure 23 , 24 , 25 , 26					
	master		$\frac{2}{CCLK}$	-	111	-	ns
	slave		$\frac{3}{CCLK}$	-	167	-	ns
t _{SPICLKL}	SPICLK LOW time	see Figure 23 , 24 , 25 , 26					
	master		$\frac{2}{CCLK}$	-	111	-	ns
	slave		$\frac{3}{CCLK}$	-	167	-	ns
t _{SPIDSU}	SPI data set-up time	see Figure 23 , 24 , 25 , 26	100	-	100	-	ns
t _{SPIDH}	SPI data hold time	see Figure 23 , 24 , 25 , 26	100	-	100	-	ns
t _{SPIA}	SPI access time	see Figure 25 , 26	0	80	0	80	ns
t _{SPIDIS}	SPI disable time	see Figure 25 , 26	0	160	-	160	ns
t _{SPIDV}	SPI enable to output data valid time	see Figure 23 , 24 , 25 , 26					
	slave		-	160	-	160	ns
	master		-	111	-	111	ns
t _{SPIOH}	SPI output data hold time	see Figure 23 , 24 , 25 , 26	0	-	0	-	ns
t _{SPIR}	SPI rise time	see Figure 23 , 24 , 25 , 26					
	SPI outputs (SPICLK, MOSI, MISO)		-	100	-	100	ns
	SPI inputs (SPICLK, MOSI, MISO, \overline{SS})		-	2000	-	2000	ns
t _{SPIF}	SPI fall time	see Figure 23 , 24 , 25 , 26					
	SPI outputs (SPICLK, MOSI, MISO)		-	100	-	100	ns
	SPI inputs (SPICLK, MOSI, MISO, \overline{SS})		-	2000	-	2000	ns

[1] Parameters are valid over ambient temperature range unless otherwise specified.

[2] Parts are tested to 2 MHz, but are guaranteed to operate down to 0 Hz.

12.1 Waveforms

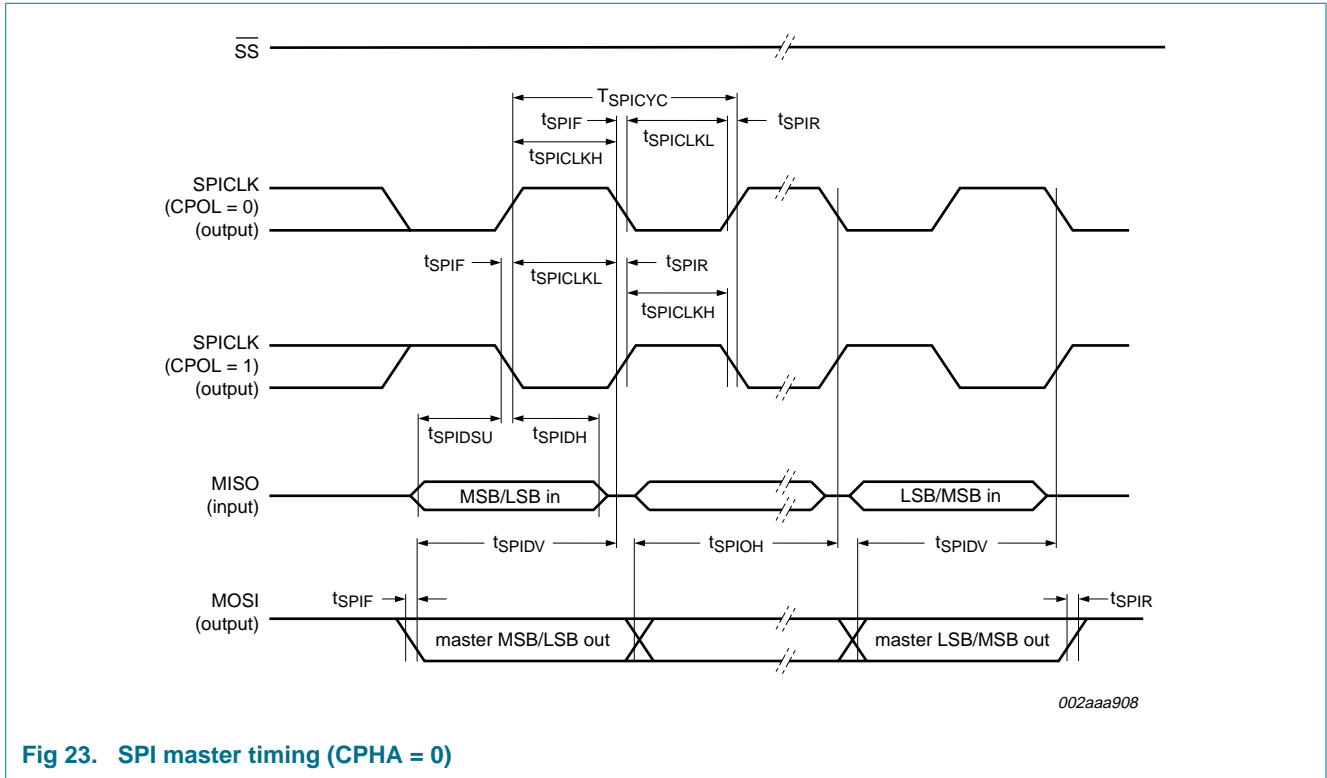

Fig 23. SPI master timing (CPHA = 0)

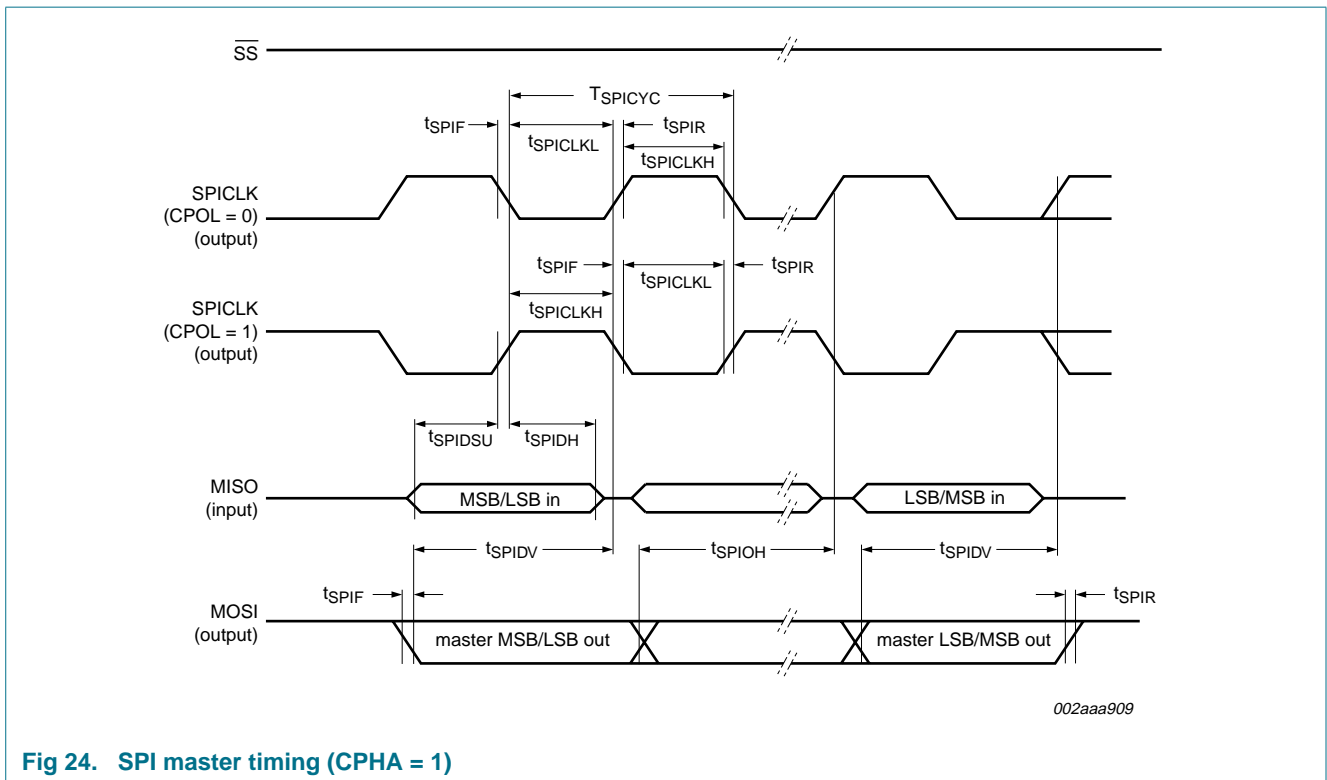

Fig 24. SPI master timing (CPHA = 1)

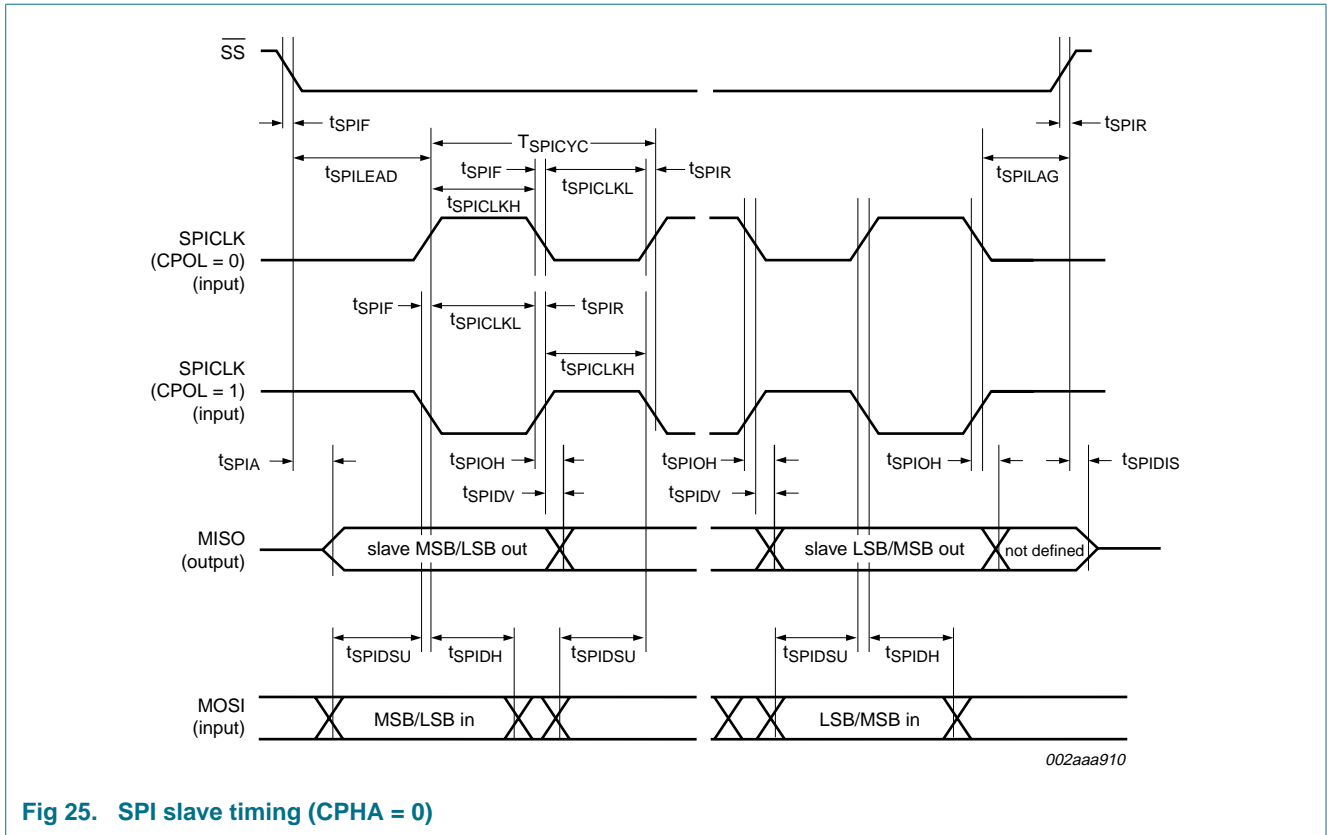

Fig 25. SPI slave timing (CPHA = 0)

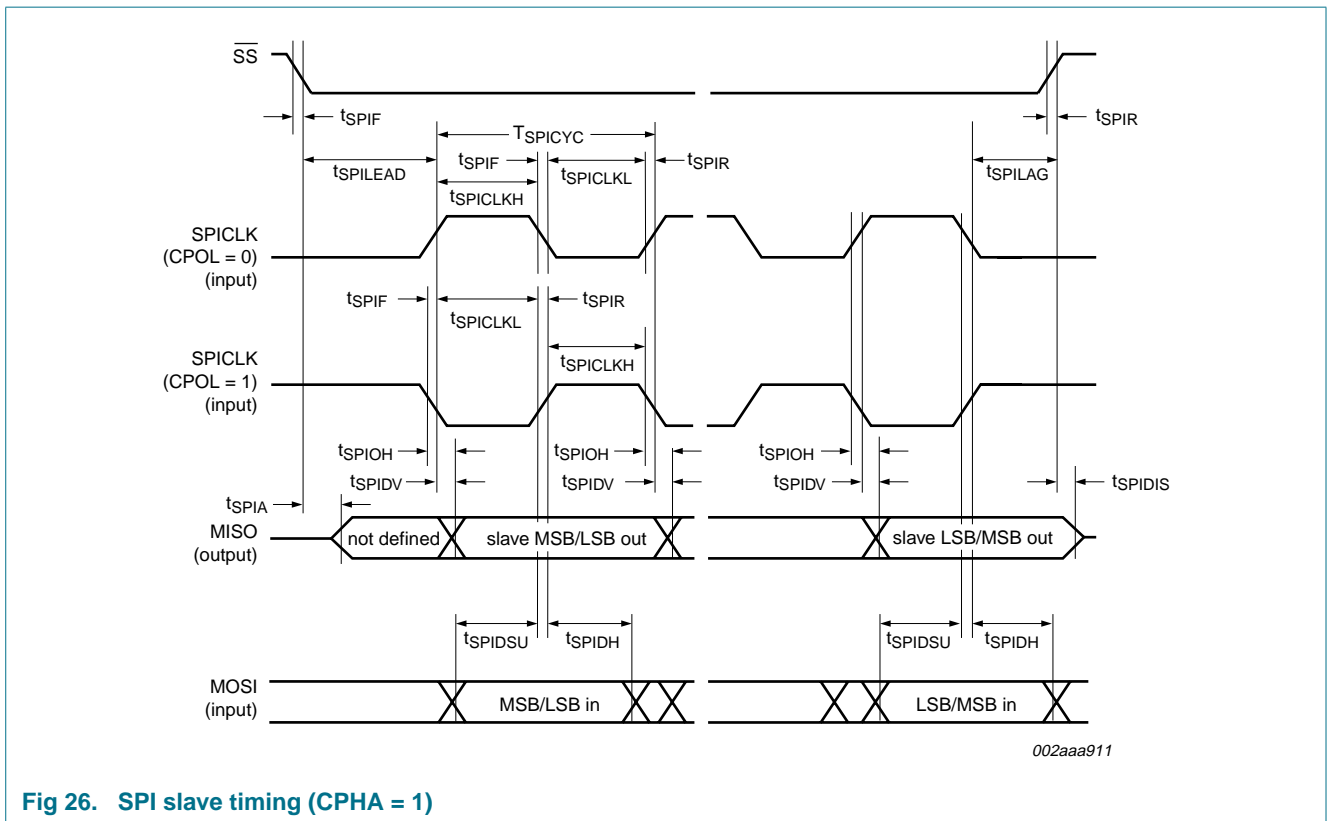

Fig 26. SPI slave timing (CPHA = 1)

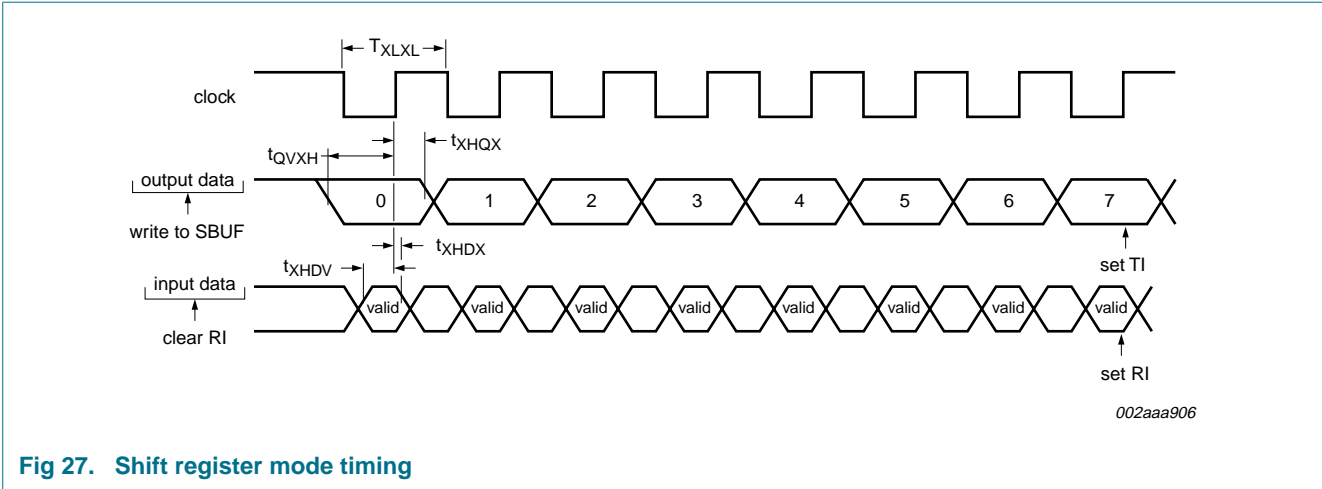

Fig 27. Shift register mode timing

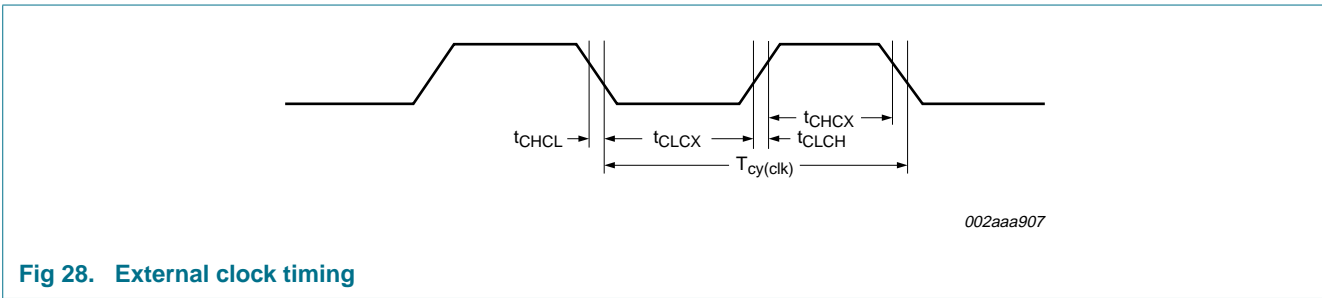

Fig 28. External clock timing

12.2 ISP entry mode

Table 18. Dynamic characteristics, ISP entry mode

$V_{DD} = 2.4 V$ to $3.6 V$, unless otherwise specified.

$T_{amb} = -40^{\circ}C$ to $+85^{\circ}C$, or $-40^{\circ}C$ to $+125^{\circ}C$ (see Table 3 on page 3), unless otherwise specified.

Symbol	Parameter	Conditions	Min	Typ	Max	Unit
t_{VR}	V_{DD} active to \overline{RST} active delay time		50	-	-	μs
t_{RH}	\overline{RST} HIGH time		1	-	32	μs
t_{RL}	\overline{RST} LOW time		1	-	-	μs

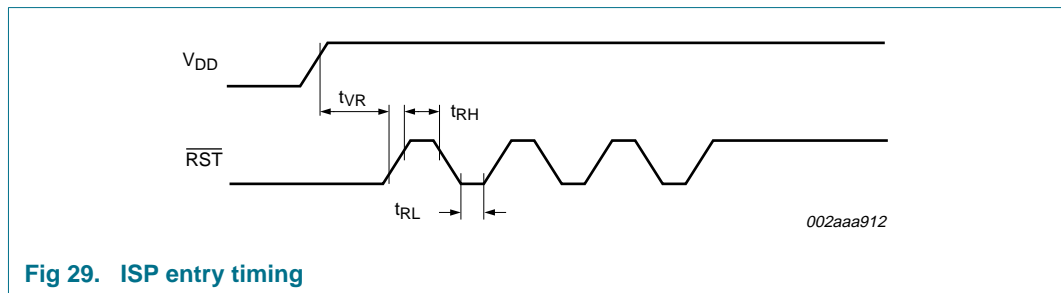

Fig 29. ISP entry timing

13. Other characteristics

13.1 Comparator electrical characteristics

Table 19. Comparator electrical characteristics

$V_{DD} = 2.4\text{ V to }3.6\text{ V}$, unless otherwise specified.

$T_{amb} = -40\text{ }^{\circ}\text{C to }+85\text{ }^{\circ}\text{C}$, or $-40\text{ }^{\circ}\text{C to }+125\text{ }^{\circ}\text{C}$ (see [Table 3 on page 3](#)), unless otherwise specified.

Symbol	Parameter	Conditions	Min	Typ	Max	Unit
V_{IO}	input offset voltage		-	-	± 20	mV
V_{IC}	common mode input voltage		0	-	$V_{DD} - 0.3$	V
CMRR	common mode rejection ratio		[1]	-	-50	dB
$t_{res(tot)}$	total response time		-	250	500	ns
$t_{(CE-OV)}$	chip enable to output valid time		-	-	10	μs
I_{LI}	input leakage current	$0 < V_I < V_{DD}$	-	-	± 10	μA

[1] This parameter is characterized, but not tested in production.

13.2 ADC electrical characteristics

Table 20. ADC electrical characteristics

$V_{DD} = 2.4\text{ V to }3.6\text{ V}$, unless otherwise specified.

$T_{amb} = -40\text{ }^{\circ}\text{C to }+85\text{ }^{\circ}\text{C}$, or $-40\text{ }^{\circ}\text{C to }+125\text{ }^{\circ}\text{C}$ (see [Table 3 on page 3](#)), unless otherwise specified.

All limits valid for an external source impedance of less than 10 k Ω .

Symbol	Parameter	Conditions	Min	Typ	Max	Unit
V_{IA}	analog input voltage		$V_{SS} - 0.2$	-	$V_{SS} + 0.2$	V
C_{ia}	analog input capacitance		-	-	15	pF
E_D	differential linearity error		-	-	± 1	LSB
$E_{L(adj)}$	integral non-linearity		-	-	± 1	LSB
E_O	offset error		-	-	± 2	LSB
E_G	gain error		-	-	± 1	%
$E_{u(tot)}$	total unadjusted error		-	-	± 2	LSB
M_{CTC}	channel-to-channel matching		-	-	± 1	LSB
$\alpha_{ct(port)}$	crosstalk between port inputs	0 kHz to 100 kHz	-	-	-60	dB
SR_{in}	input slew rate		-	-	100	V/ms
$T_{cy(ADC)}$	ADC clock cycle		111	-	2000	ns
t_{ADC}	conversion time	A/D enabled	-	-	$13T_{cy(ADC)}$	ns

14. Package outline

DIP14: plastic dual in-line package; 14 leads (300 mil)

SOT27-1

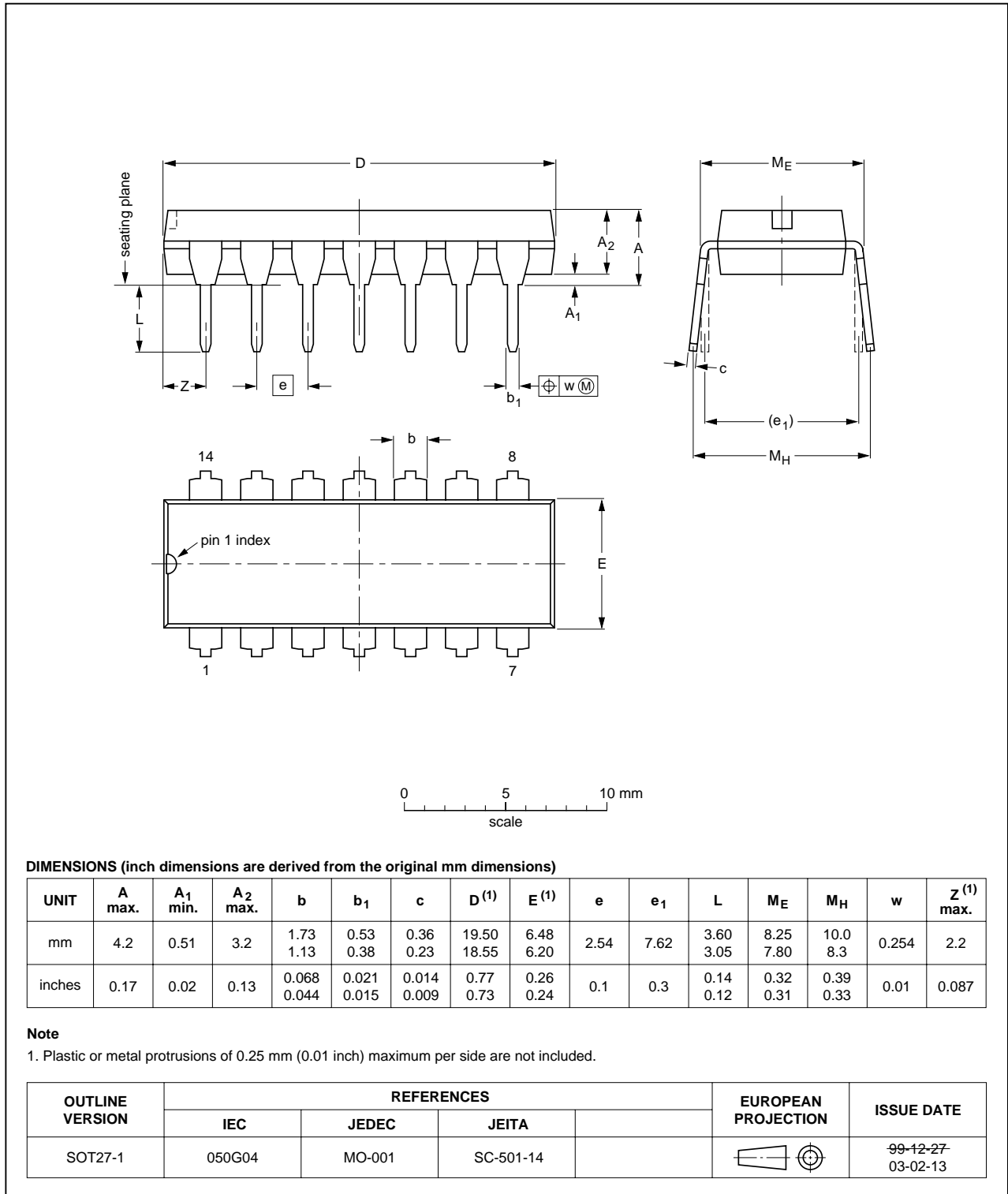

Fig 30. Package outline SOT27-1 (DIP14)

TSSOP14: plastic thin shrink small outline package; 14 leads; body width 4.4 mm

SOT402-1

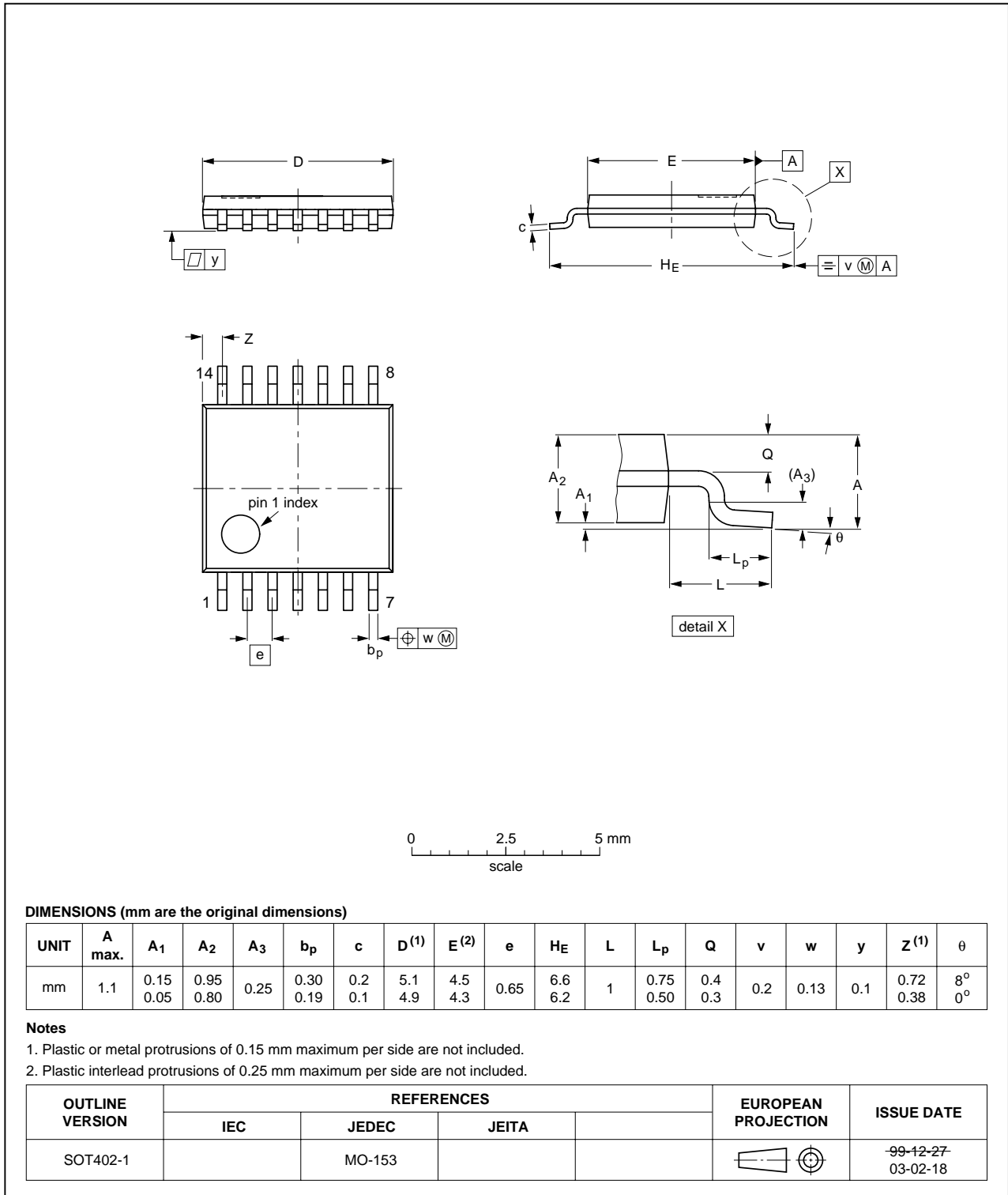

Fig 31. Package outline SOT402-1 (TSSOP14)

TSSOP16: plastic thin shrink small outline package; 16 leads; body width 4.4 mm

SOT403-1

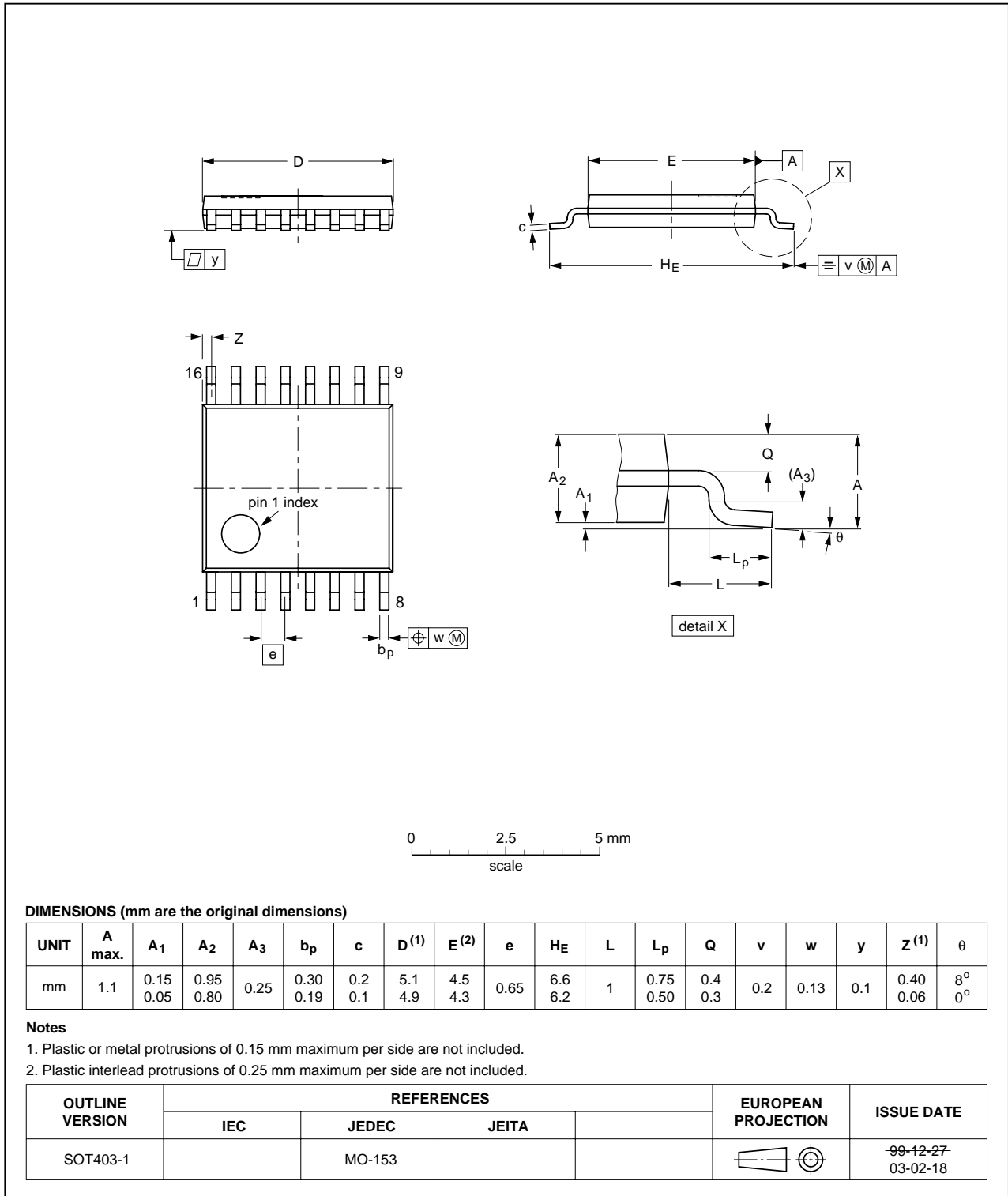

Fig 32. Package outline SOT403-1 (TSSOP16)

15. Abbreviations

Table 21. Acronym list

Acronym	Description
ADC	Analog to Digital Converter
CPU	Central Processing Unit
CCU	Capture/Compare Unit
DAC	Digital to Analog Converter
EPROM	Erasable Programmable Read-Only Memory
EEPROM	Electrically Erasable Programmable Read-Only Memory
EMI	ElectroMagnetic Interference
PLL	Phase-Locked Loop
PWM	Pulse Width Modulator
RAM	Random Access Memory
RC	Resistance-Capacitance
RTC	Real-Time Clock
SAR	Successive Approximation Register
SFR	Special Function Register
SPI	Serial Peripheral Interface
UART	Universal Asynchronous Receiver/Transmitter

16. Revision history

Table 22. Revision history

Document ID	Release date	Data sheet status	Change notice	Supersedes
P89LPC915_916_917_5	20091215	Product data sheet	-	P89LPC915_916_917-04
Modifications:		<ul style="list-style-type: none"> The format of this data sheet has been redesigned to comply with the new identity guidelines of NXP Semiconductors. Legal texts have been adapted to the new company name where appropriate. Added ADC electrical characteristics, Table 20. Added P89LPC915FN. 		
P89LPC915_916_917-04	20041217	Product data	-	P89LPC915_916_917-03
P89LPC915_916_917-03	20040701	Preliminary data	-	P89LPC915_916_917-02
P89LPC915_916_917-02	20040512	Preliminary data	-	P89LPC915_916_917-01
P89LPC915_916_917-01	20040408	Preliminary data	-	-

17. Legal information

17.1 Data sheet status

Document status ^{[1][2]}	Product status ^[3]	Definition
Objective [short] data sheet	Development	This document contains data from the objective specification for product development.
Preliminary [short] data sheet	Qualification	This document contains data from the preliminary specification.
Product [short] data sheet	Production	This document contains the product specification.

[1] Please consult the most recently issued document before initiating or completing a design.

[2] The term 'short data sheet' is explained in section "Definitions".

[3] The product status of device(s) described in this document may have changed since this document was published and may differ in case of multiple devices. The latest product status information is available on the Internet at URL <http://www.nxp.com>.

17.2 Definitions

Draft — The document is a draft version only. The content is still under internal review and subject to formal approval, which may result in modifications or additions. NXP Semiconductors does not give any representations or warranties as to the accuracy or completeness of information included herein and shall have no liability for the consequences of use of such information.

Short data sheet — A short data sheet is an extract from a full data sheet with the same product type number(s) and title. A short data sheet is intended for quick reference only and should not be relied upon to contain detailed and full information. For detailed and full information see the relevant full data sheet, which is available on request via the local NXP Semiconductors sales office. In case of any inconsistency or conflict with the short data sheet, the full data sheet shall prevail.

17.3 Disclaimers

General — Information in this document is believed to be accurate and reliable. However, NXP Semiconductors does not give any representations or warranties, expressed or implied, as to the accuracy or completeness of such information and shall have no liability for the consequences of use of such information.

Right to make changes — NXP Semiconductors reserves the right to make changes to information published in this document, including without limitation specifications and product descriptions, at any time and without notice. This document supersedes and replaces all information supplied prior to the publication hereof.

Suitability for use — NXP Semiconductors products are not designed, authorized or warranted to be suitable for use in medical, military, aircraft, space or life support equipment, nor in applications where failure or malfunction of an NXP Semiconductors product can reasonably be expected to result in personal injury, death or severe property or environmental

damage. NXP Semiconductors accepts no liability for inclusion and/or use of NXP Semiconductors products in such equipment or applications and therefore such inclusion and/or use is at the customer's own risk.

Applications — Applications that are described herein for any of these products are for illustrative purposes only. NXP Semiconductors makes no representation or warranty that such applications will be suitable for the specified use without further testing or modification.

Limiting values — Stress above one or more limiting values (as defined in the Absolute Maximum Ratings System of IEC 60134) may cause permanent damage to the device. Limiting values are stress ratings only and operation of the device at these or any other conditions above those given in the Characteristics sections of this document is not implied. Exposure to limiting values for extended periods may affect device reliability.

Terms and conditions of sale — NXP Semiconductors products are sold subject to the general terms and conditions of commercial sale, as published at <http://www.nxp.com/profile/terms>, including those pertaining to warranty, intellectual property rights infringement and limitation of liability, unless explicitly otherwise agreed to in writing by NXP Semiconductors. In case of any inconsistency or conflict between information in this document and such terms and conditions, the latter will prevail.

No offer to sell or license — Nothing in this document may be interpreted or construed as an offer to sell products that is open for acceptance or the grant, conveyance or implication of any license under any copyrights, patents or other industrial or intellectual property rights.

Export control — This document as well as the item(s) described herein may be subject to export control regulations. Export might require a prior authorization from national authorities.

17.4 Trademarks

Notice: All referenced brands, product names, service names and trademarks are the property of their respective owners.

I²C-bus — logo is a trademark of NXP B.V.

18. Contact information

For more information, please visit: <http://www.nxp.com>

For sales office addresses, please send an email to: salesaddresses@nxp.com

19. Contents

1	General description	1	8.17.1	Mode 0	40
2	Features	1	8.17.2	Mode 1	40
2.1	Principal features	1	8.17.3	Mode 2	40
2.2	Additional features	1	8.17.4	Mode 3	40
3	Product comparison overview	2	8.17.5	Mode 6	40
4	Ordering information	3	8.17.6	Timer overflow toggle output	40
4.1	Ordering options	3	8.18	RTC/system timer	40
5	Block diagram	4	8.19	UART	41
6	Functional diagram	7	8.19.1	Mode 0	41
7	Pinning information	9	8.19.2	Mode 1	41
7.1	Pinning	9	8.19.3	Mode 2	41
7.2	Pin description	11	8.19.4	Mode 3	41
8	Functional description	18	8.19.5	Baud rate generator and selection	42
8.1	Special function registers	18	8.19.6	Framing error	42
8.2	Enhanced CPU	31	8.19.7	Break detect	42
8.3	Clocks	31	8.19.8	Double buffering	42
8.3.1	Clock definitions	31	8.19.9	Transmit interrupts with double buffering	42
8.3.2	CPU clock (OSCCLK)	31	8.19.10	enabled (Modes 1, 2 and 3)	42
8.3.3	Clock output (P89LPC917)	31	8.20	The 9 th bit (bit 8) in double buffering	43
8.4	On-chip RC oscillator option	31	8.21	(Modes 1, 2 and 3)	43
8.5	Watchdog oscillator option	31	8.21.1	I ² C-bus serial interface	43
8.6	External clock input option	32	8.21.2	SPI	45
8.7	CCLK wake-up delay	32	8.22	Typical SPI configurations	46
8.8	CCLK modification: DIVM register	32	8.22.1	Analog comparators	48
8.9	Low power select	33	8.22.2	Internal reference voltage	48
8.10	Memory organization	33	8.22.3	Comparator interrupt	48
8.11	Data RAM arrangement	33	8.23	Comparators and power reduction modes	48
8.12	Interrupts	33	8.24	KBI	49
8.12.1	External interrupt inputs	34	8.25	Watchdog timer	50
8.13	I/O ports	36	8.25.1	Additional features	50
8.13.1	Port configurations	36	8.25.2	Software reset	50
8.13.1.1	Quasi-bidirectional output configuration	36	8.26	Dual data pointers	50
8.13.1.2	Open-drain output configuration	37	8.26.1	Flash program memory	51
8.13.1.3	Input-only configuration	37	8.26.2	General description	51
8.13.1.4	Push-pull output configuration	37	8.26.3	Features	51
8.13.2	Port 0 analog functions	37	8.26.4	Flash organization	51
8.13.3	Additional port features	37	8.26.5	Using flash as data storage	51
8.14	Power monitoring functions	38	8.26.6	Flash programming and erasing	51
8.14.1	Brownout detection	38	8.26.7	ICP	52
8.14.2	Power-on detection	38	8.26.8	IAP-Lite	52
8.15	Power reduction modes	38	8.26.9	Power-on reset code execution	52
8.15.1	Idle mode	38	8.27	Hardware activation of the alternate code	52
8.15.2	Power-down mode	38	8.28	User configuration bytes	52
8.15.3	Total Power-down mode	39	9	User sector security bytes	53
8.16	Reset	39	9	A/D converter	53
8.17	Timers/counters 0 and 1	39	9.1	General description	53
			9.2	Features	53
			9.3	Block diagram	54

continued >>

9.4	A/D operating modes	54
9.4.1	Fixed channel, single conversion mode	54
9.4.2	Fixed channel, continuous conversion mode	54
9.4.3	Auto scan, single conversion mode	54
9.4.4	Auto scan, continuous conversion mode	55
9.4.5	Dual channel, continuous conversion mode	55
9.4.6	Single step mode	55
9.5	Conversion start modes	55
9.5.1	Timer triggered start	55
9.5.2	Start immediately	55
9.5.3	Edge triggered	55
9.6	Boundary limits interrupt.	55
9.7	DAC output to a port pin with high output impedance	56
9.8	Clock divider	56
9.9	Power-down and Idle mode	56
10	Limiting values	57
11	Static characteristics	58
12	Dynamic characteristics	60
12.1	Waveforms	64
12.2	ISP entry mode	66
13	Other characteristics	67
13.1	Comparator electrical characteristics	67
13.2	ADC electrical characteristics	67
14	Package outline	68
15	Abbreviations	71
16	Revision history	72
17	Legal information	73
17.1	Data sheet status	73
17.2	Definitions	73
17.3	Disclaimers	73
17.4	Trademarks	73
18	Contact information	73
19	Contents	74

Please be aware that important notices concerning this document and the product(s) described herein, have been included in section 'Legal information'.

founded by

PHILIPS

© NXP B.V. 2009.

All rights reserved.

For more information, please visit: <http://www.nxp.com>



For sales office addresses, please send an email to: salesaddresses@nxp.com

Date of release: 15 December 2009

Document identifier: P89LPC915_916_917_5

Looking for pricing, stock, or lifecycle information?

Click below to explore more details on WIN SOURCE:

-  [View P89LPC917FDH,129 on WIN SOURCE](#)
-  [NXP / Nexperia Information](#)

Optimize Your Supply Chain with WIN SOURCE Solutions

-  Global Sourcing Solution
-  Obsolete Management
-  Cost Control Management
-  Shortage Management
-  Alternative Solution
-  Excess Inventory Management