



**THE DATASHEET OF
LP3905SD-A3EV**



AN-1527 LP3905-A3 Application Board

1 General Information

The evaluation board is a complete circuit allowing full operation of the LP3905 within the recommended application circuit. Each board is pre-assembled and tested in the factory. The board contains the LP3905-A3 in a 14 lead WSON package with all the associated passive components to enable all features of the device to be tested.

LP3905 is optimized for low power handheld applications. This device provides two 600mA DC/DC Buck regulators, and two 100mA linear regulators as configured on the board. The LP3905-A3 allows the two buck output voltages to be set by the user. This option is a variation on the LP3905 device that has 4 fixed output voltages. The LP3905 additionally features two enable pins allowing control over the device outputs.

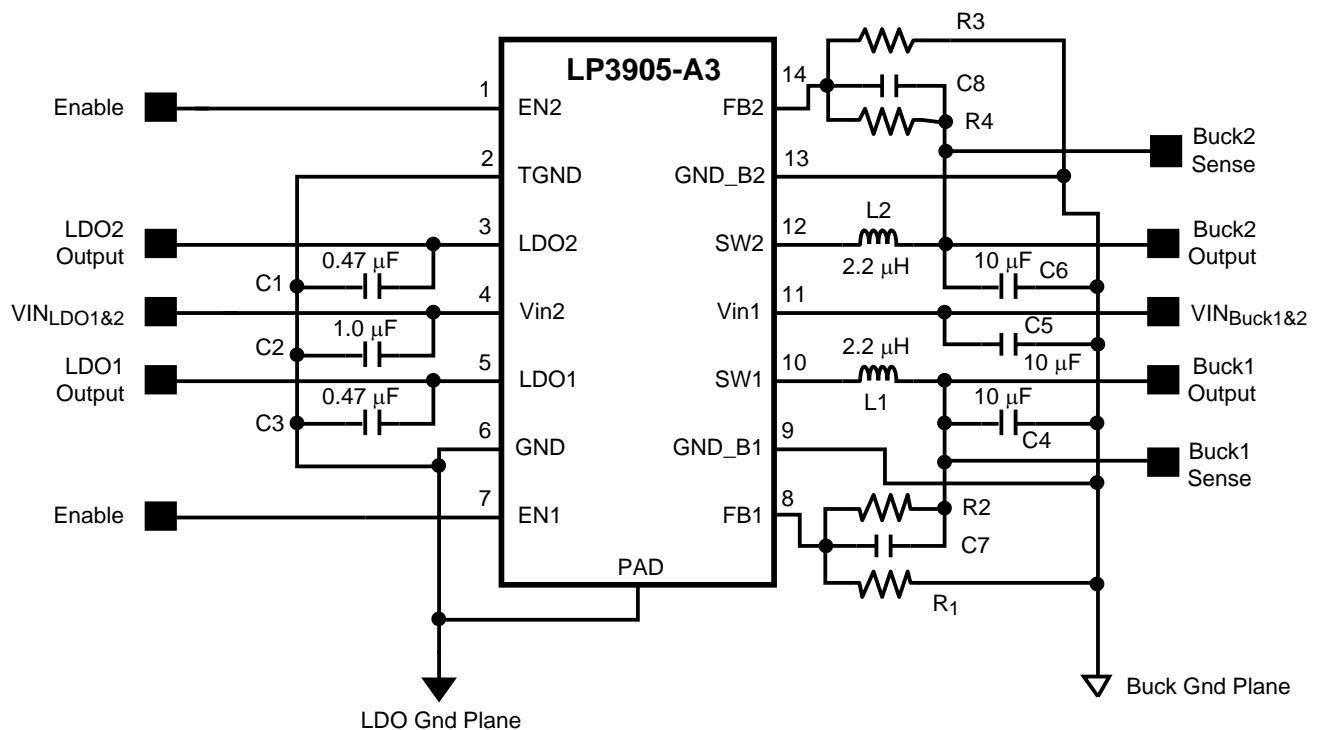

Figure 1. Evaluation Board Schematic

2 Operational Information

The LP3905-A3 evaluation board has the output voltages set as follows:

Table 1. LP3905-A3 Output Voltages

O/P	Voltage (V)
Buck1	1.5
Buck2	1.85
LDO1	3.0
LDO2	2.8

The board is fitted with 0.47 μ F capacitors on the outputs of the LDO's and thus the load current for these LDO's should not exceed 100mA.

The device has 1M Ω internal resistors from EN1 and EN2 to GND.

3 Output Voltage Pre-Set

For initial use the LP3905-A3 sample board has been pre-set to 1.5V and 1.85V. The outputs of these two regulators may be set via the selection of the external resistor network forming the output feedback between the output voltage side of the inductor and the feedback pins (FB1, FB2) of the device and the feedback pins and ground. The user should thus alter the values of R1, R2 and C7 to give the desired output voltage on Buck1 and R3, R4, and C8 to change the output voltage on Buck2.

4 Output Voltage Selection

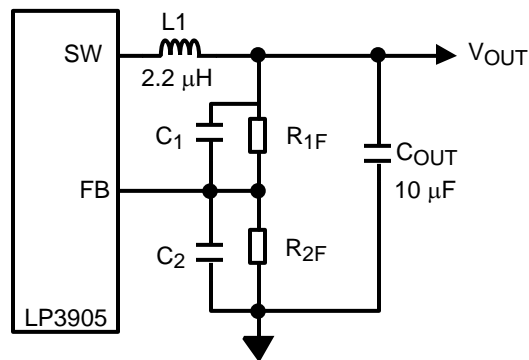

Figure 2. Adjustable Buck Components showing Resistor Feedback Network

The recommended resistance between FB and GND is around 200k Ω . At this level the current through the resistor network is low but does not give rise to noise problems. The feedback node voltage is 0.5V and hence a 200k Ω resistor will result in a 2.5 μ A current.

The formula for output voltage selection is:

$$V_{OUT} = V_{FB} \times \left(1 + \frac{R_{1F}}{R_{2F}}\right) \quad (1)$$

where:

V_{OUT} = output voltage (Volts)

V_{FB} = feedback voltage (0.5V)

R_{1F} = feedback resistor (V_{OUT} to FB)

R_{2F} = feedback resistor (FB to GND)

For any output voltage greater than or equal to 1.0V, a capacitor should be added across R_{1F} . The chosen value of the capacitor is governed by the formula:

$$C_1 = \frac{1}{(2 \times \pi \times R_{1F} \times 45 \times 10^3)} \quad (2)$$

The value of this capacitor may be chosen from [Table 2](#) giving the recommended component values for specified output voltages. C2 shown between the FB node and GND is only required at higher output voltages.

Table 2. Recommended Component Values for Specified Output Voltages

V_{OUT} (V)	R_{1F} (k Ω)	R_{2F} (k Ω)	C1 (pF)	C2 (pF)
1.0	200	200	18	none
1.2	280	200	12	none
1.4	357	200	10	none
1.5	365	182	10	none
1.6	442	200	8.2	none
1.85	536	200	6.8	none
2.5	402	100	8.2	none
2.8	464	100	8.2	33
3.3	562	100	6.8	33

5 Connection Information

Connect a supply voltage (3.0V to 5.5V) to either of the VIN pins on the evaluation board. LK4 hardwired on the board connects both the BUCK supply side to the LDO supply side. These supplies are both required to correctly power the device.

Supply ground may be connected at either GND or BKGND. LK3 which is hardwired on the eval board connects the BUCK gnd to the LDO gnd.

For best results in current measurements on the Buck outputs, use 4 wire measurement techniques to eliminate any voltage drop on the PCB traces or connecting wires to the loads. For this the instrument sense connection should be connected to the corresponding buck 'S' (sense) connection on the evaluation board.

Input leads should be kept reasonably short to minimize inductance.

ON/OFF control is provided by logic signals on EN1 and EN2. A minimum of 1.2V is required on these pins to enable the corresponding outputs. The outputs will be shutdown with the enable pins set to 0.4V or less. If ON/OFF control is not required, then either or both enable pins may be connected to V_{IN} either externally or by using the on-board connection matrix.

A number of control options are provided on board by either hardwiring or using reconfigurable links on the 4-way matrix.

Table 3. Link Matrix Details

Link	Link	Connection Description
1 - 2	3 - 4	EN1 and EN2 connect to VIN supply. All outputs power on with the supply voltage.
3 - 4	-	EN1 connects to EN2 and may be driven externally from one source to control all outputs.
1 - 2	-	EN1 connects to VIN. Buck1, LDO1, and LDO2 outputs are enabled at device power up. Buck 2 should be enabled separately using an external source connected to EN2.
1 - 3	-	EN2 connects to VIN. Buck 2 is enabled at device power up. Buck1, LDO1, and LDO2 outputs should be enabled using an external source connected to EN1.
-	-	Both EN1 and EN2 can be driven separately from external sources connected at the board inputs EN1 and EN2.

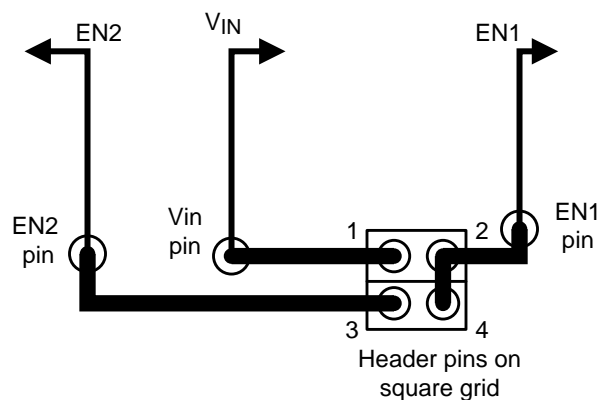

Figure 3. Link Matrix Diagram

6 PCB Layout

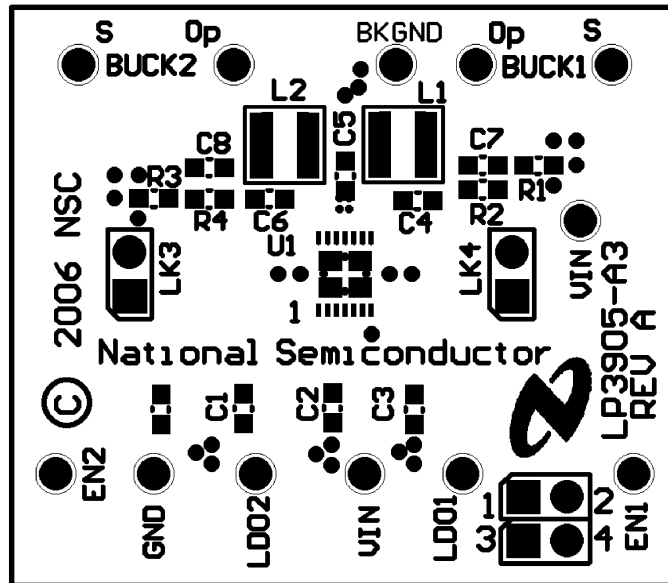

Figure 4. PCB Component and Pin Layout
Board Size 1.5" x 1.3"

7 Bill of Materials

Table 4. Bill of Materials for LP3905-A3 WSON Evaluation Board

Item	Type	Value	Qty	Part Number Suggested	Manufacturer	Footprint
U1			1	LP3905	Texas Instruments	NHL0014B
L1,L2	Inductor	2.2 μ F	1	DO3314-222MLB ⁽¹⁾	Coilcraft	
C1, C3	Capacitor	0.47 μ F	2	GRM188R61A474KA61D ⁽¹⁾	Murata	0603
C4, C5, C6	Capacitor	10 μ F	3	GRM21BR61A106KE19L ⁽¹⁾	Murata	0805
C2	Capacitor	1.0nF	1	GRM188R61A105KA61D ⁽¹⁾	Murata	0603
C7	Capacitor	10pF	1	GRM1885C1H100JZ01B ⁽¹⁾	Murata	0603
C8	Capacitor	6.8pF	1	GRM1885C1H6R8DZ01B ⁽¹⁾	Murata	0603
R1	Resistor	182 Ω	1	CRCW06031823F ⁽¹⁾	Vishay	0603, 1%
R2	Resistor	365 Ω	1	CRCW06033653F ⁽¹⁾	Vishay	0603, 1%
R3	Resistor	200 Ω	1	CRCW06032003F ⁽¹⁾	Vishay	0603, 1%
R4	Resistor	536 Ω	1	CRCW06035363F ⁽¹⁾	Vishay	0603, 1%

⁽¹⁾ or similar

IMPORTANT NOTICE

Texas Instruments Incorporated and its subsidiaries (TI) reserve the right to make corrections, enhancements, improvements and other changes to its semiconductor products and services per JESD46, latest issue, and to discontinue any product or service per JESD48, latest issue. Buyers should obtain the latest relevant information before placing orders and should verify that such information is current and complete. All semiconductor products (also referred to herein as "components") are sold subject to TI's terms and conditions of sale supplied at the time of order acknowledgment.

TI warrants performance of its components to the specifications applicable at the time of sale, in accordance with the warranty in TI's terms and conditions of sale of semiconductor products. Testing and other quality control techniques are used to the extent TI deems necessary to support this warranty. Except where mandated by applicable law, testing of all parameters of each component is not necessarily performed.

TI assumes no liability for applications assistance or the design of Buyers' products. Buyers are responsible for their products and applications using TI components. To minimize the risks associated with Buyers' products and applications, Buyers should provide adequate design and operating safeguards.

TI does not warrant or represent that any license, either express or implied, is granted under any patent right, copyright, mask work right, or other intellectual property right relating to any combination, machine, or process in which TI components or services are used. Information published by TI regarding third-party products or services does not constitute a license to use such products or services or a warranty or endorsement thereof. Use of such information may require a license from a third party under the patents or other intellectual property of the third party, or a license from TI under the patents or other intellectual property of TI.

Reproduction of significant portions of TI information in TI data books or data sheets is permissible only if reproduction is without alteration and is accompanied by all associated warranties, conditions, limitations, and notices. TI is not responsible or liable for such altered documentation. Information of third parties may be subject to additional restrictions.

Resale of TI components or services with statements different from or beyond the parameters stated by TI for that component or service voids all express and any implied warranties for the associated TI component or service and is an unfair and deceptive business practice. TI is not responsible or liable for any such statements.

Buyer acknowledges and agrees that it is solely responsible for compliance with all legal, regulatory and safety-related requirements concerning its products, and any use of TI components in its applications, notwithstanding any applications-related information or support that may be provided by TI. Buyer represents and agrees that it has all the necessary expertise to create and implement safeguards which anticipate dangerous consequences of failures, monitor failures and their consequences, lessen the likelihood of failures that might cause harm and take appropriate remedial actions. Buyer will fully indemnify TI and its representatives against any damages arising out of the use of any TI components in safety-critical applications.

In some cases, TI components may be promoted specifically to facilitate safety-related applications. With such components, TI's goal is to help enable customers to design and create their own end-product solutions that meet applicable functional safety standards and requirements. Nonetheless, such components are subject to these terms.

No TI components are authorized for use in FDA Class III (or similar life-critical medical equipment) unless authorized officers of the parties have executed a special agreement specifically governing such use.

Only those TI components which TI has specifically designated as military grade or "enhanced plastic" are designed and intended for use in military/aerospace applications or environments. Buyer acknowledges and agrees that any military or aerospace use of TI components which have **not** been so designated is solely at the Buyer's risk, and that Buyer is solely responsible for compliance with all legal and regulatory requirements in connection with such use.

TI has specifically designated certain components as meeting ISO/TS16949 requirements, mainly for automotive use. In any case of use of non-designated products, TI will not be responsible for any failure to meet ISO/TS16949.

Products

Audio	www.ti.com/audio
Amplifiers	amplifier.ti.com
Data Converters	dataconverter.ti.com
DLP® Products	www.dlp.com
DSP	dsp.ti.com
Clocks and Timers	www.ti.com/clocks
Interface	interface.ti.com
Logic	logic.ti.com
Power Mgmt	power.ti.com
Microcontrollers	microcontroller.ti.com
RFID	www.ti-rfid.com
OMAP Applications Processors	www.ti.com/omap
Wireless Connectivity	www.ti.com/wirelessconnectivity

Applications

Automotive and Transportation	www.ti.com/automotive
Communications and Telecom	www.ti.com/communications
Computers and Peripherals	www.ti.com/computers
Consumer Electronics	www.ti.com/consumer-apps
Energy and Lighting	www.ti.com/energy
Industrial	www.ti.com/industrial
Medical	www.ti.com/medical
Security	www.ti.com/security
Space, Avionics and Defense	www.ti.com/space-avionics-defense
Video and Imaging	www.ti.com/video

TI E2E Community

e2e.ti.com

Looking for pricing, stock, or lifecycle information?

Click below to explore more details on WIN SOURCE:

 [View LP3905SD-A3EV](#) on WIN SOURCE

 [Texas Instruments](#) Information

Optimize Your Supply Chain with WIN SOURCE Solutions

-  Global Sourcing Solution
-  Obsolete Management
-  Cost Control Management
-  Shortage Management
-  Alternative Solution
-  Excess Inventory Management