



**THE DATASHEET OF
LP38513S-1.8EV**



AN-1518 LP38513S-1.8 Evaluation Board

1 Introduction

This board is designed to enable the evaluation of the LP38513S-1.8 Voltage Regulator. Each board is assembled and tested in the factory. This evaluation board has the TO-263 5–lead package mounted.

2 General Description

The LP38513 is a linear regulator capable of supplying up to 3A of output current, and incorporates Enable and $\overline{\text{Error}}$ flag features.

The device has been designed to work with 10 μF ceramic input and output capacitors. Footprints areas for C_{IN} and C_{OUT} will allow for a variety of sizes.

3 Operation

The input voltage, applied between V_{IN} and GND, should be at least 2.25V, and no higher than 5.5V.

Loads can be connected to V_{OUT} with reference to GND.

Test points are provided on the board to allow monitoring of V_{OUT} , V_{IN} , Enable, and $\overline{\text{ERROR}}$ signals during operation

If the application does not require the Enable function, the EN pin should be connected to directly to the adjacent V_{IN} pin.

4 Enable Operation

The Enable On/Off threshold is typically 850 mV, and has no hysteresis. The voltage signal must rise and fall cleanly, and promptly, through this threshold.

The Enable pin (EN) has no internal pull-up or pull-down to establish a default condition and, as a result, this pin must be terminated either actively or passively.

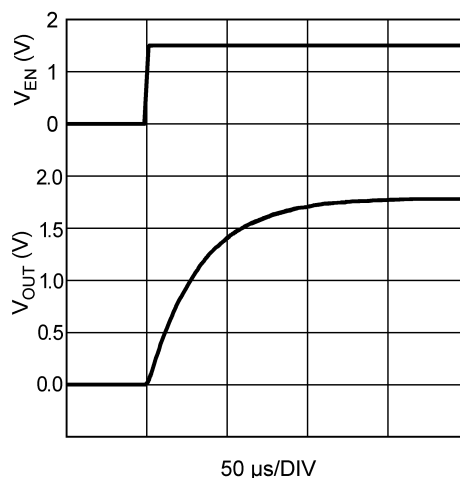

Figure 1. V_{OUT} vs. V_{EN}

All trademarks are the property of their respective owners.

If the Enable pin is driven from a single ended device (such as the collector of a discrete transistor) a pull-up resistor to V_{IN} , or a pull-down resistor to ground, will be required for proper operation. A 1 k Ω to 100 k Ω resistor can be used as the pull-up or pull-down resistor to establish default condition for the EN pin. The resistor value selected should be appropriate to swamp out any leakage in the external single ended device, as well as any stray capacitance.

If the Enable pin is driven from a source that actively pulls high and low (such as a CMOS rail to rail comparator output), the pull-up, or pull-down, resistor is not required.

If the application does not require the Enable function, the EN pin should be connected directly to the adjacent V_{IN} pin.

The status of the Enable pin also affects the behavior of the $\overline{\text{ERROR}}$ Flag. While the Enable pin is high the regulator control loop will be active and the $\overline{\text{ERROR}}$ Flag will report the status of the output voltage. When the Enable pin is taken low the regulator control loop is shutdown, the output is turned off, and the internal logic will immediately force the $\overline{\text{ERROR}}$ Flag pin low.

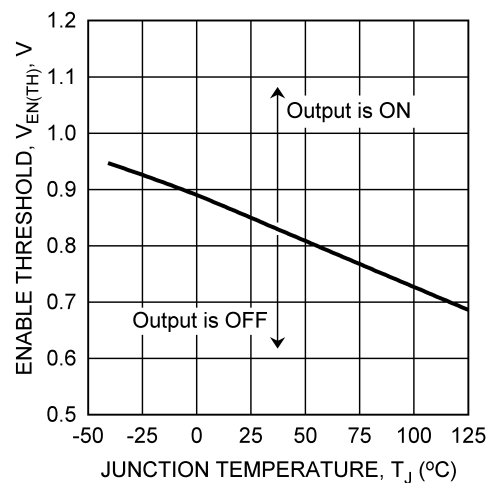

Figure 2. Enable Threshold

5 ERROR Flag

When the LP38513 Enable pin is high, the $\overline{\text{ERROR}}$ Flag pin will produce a logic low signal when the output drops by more than 10% (typical) from the nominal output voltage. The drop in output voltage may be due to low input voltage, current limiting, or thermal limiting. This flag has a built in hysteresis. The output voltage will need to rise to within 5% of the nominal output voltage for the $\overline{\text{ERROR}}$ Flag to return to a logic high state. It should also be noted that when the Enable pin is pulled low, the $\overline{\text{ERROR}}$ Flag pin is forced to be low as well.

The internal $\overline{\text{ERROR}}$ flag comparator has an open drain output stage. Hence, the $\overline{\text{ERROR}}$ pin requires an external pull-up resistor. The value of the pull-up resistor should be in the range of 2 k Ω to 100 k Ω , and should be connected to the LP38513 output voltage pin. The $\overline{\text{ERROR}}$ Flag pin should not be pulled-up to any voltage source higher than V_{IN} as current flow through an internal parasitic diode may cause unexpected behavior. When the input voltage is less than typically 1.25V the status of the $\overline{\text{ERROR}}$ Flag output will not be reliable. The $\overline{\text{ERROR}}$ Flag pin must be connected to ground if this function is not used.

The timing diagram in Figure 3 shows the relationship between the $\overline{\text{ERROR}}$ flag and the output voltage when the pull-up resistor is connected to the output voltage pin.

The timing diagram in Figure 4 shows the relationship between the $\overline{\text{ERROR}}$ flag and the output voltage when the pull-up resistor is connected to the input voltage pin.

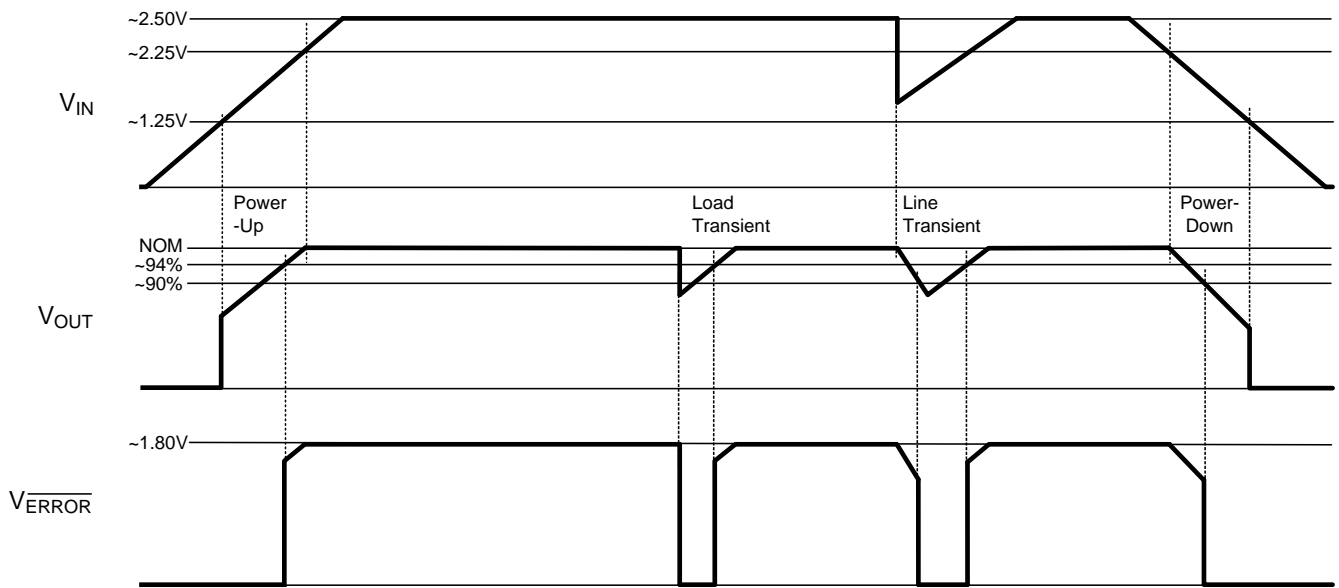

Figure 3. *ERROR* Flag when Pull-Up is from V_{OUT}

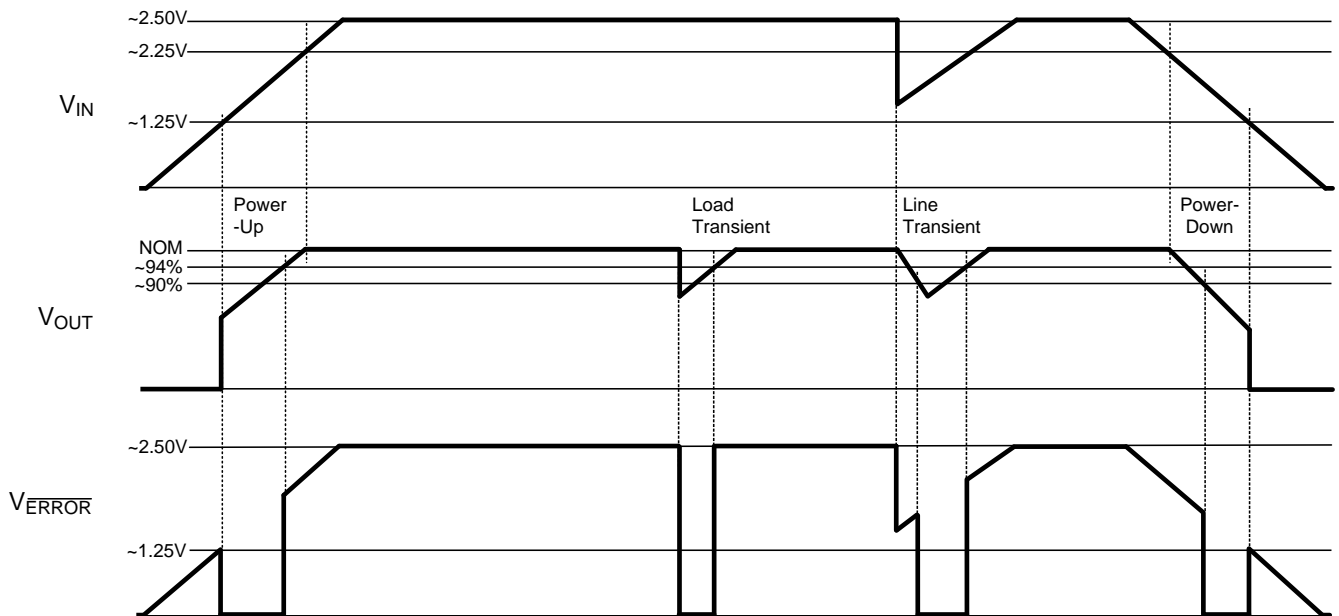

Figure 4. *ERROR* Flag when Pull-Up is from V_{IN}

6 Power Dissipation

The TO-263 package alone has a junction to ambient thermal resistance (θ_{JA}) rating of 60°C/W. When mounted on the LP38513S evaluation board the θ_{JA} rating is approximately 30°C/W.

Although there is only approximately 0.28 square inches of 1 ounce copper area immediately under the tab, the top copper surface area is extended to an additional copper area, 1 square inch of 1 ounce copper, on the bottom of the board by the use of nine thermal vias.

With the 30°C/W thermal rating the LP38513S-1.8 evaluation board will deliver the rated 3A output current if $V_{IN} = 2.5V$, $V_{OUT} = 1.8V$, and $T_A \leq 25^\circ C$.

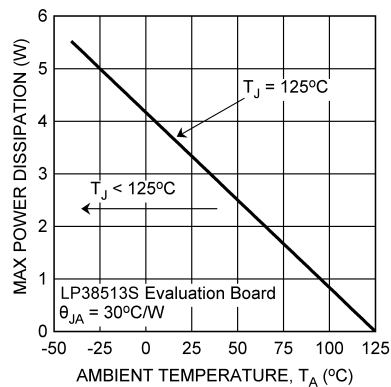
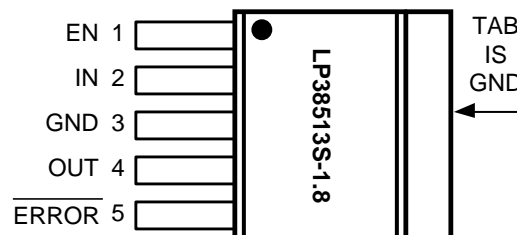

Figure 5. Maximum Power Dissipation vs. Ambient Temperature

7 Connection Diagram



8 Schematic Diagram

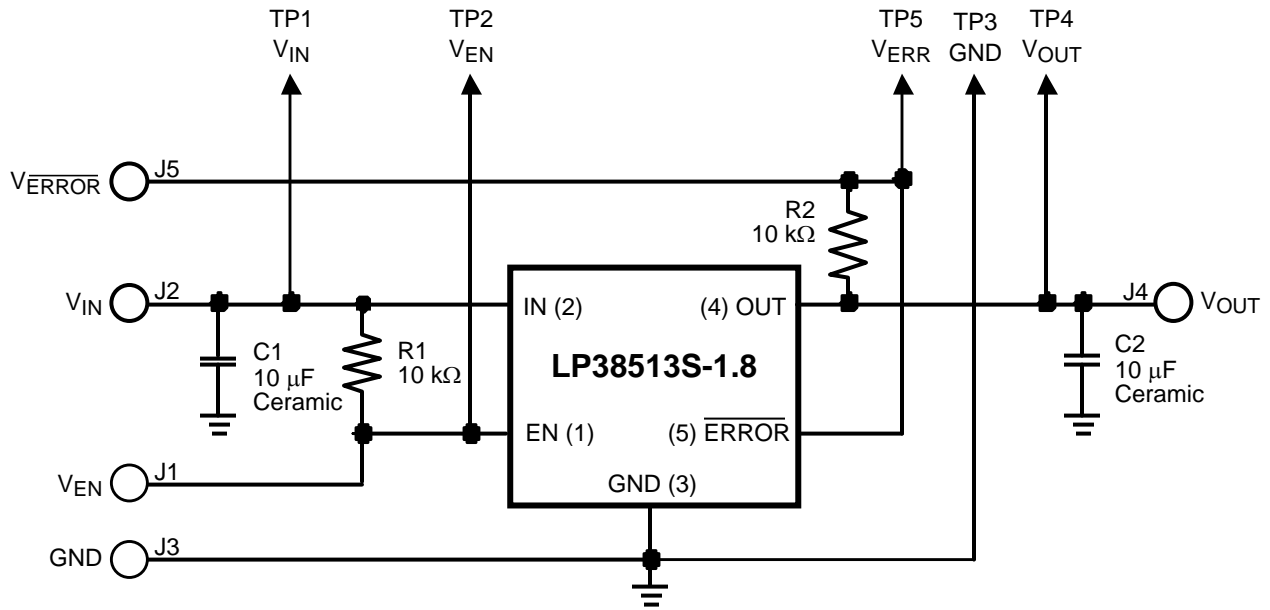

Figure 6. Evaluation Board Schematic

9 PCB Layout

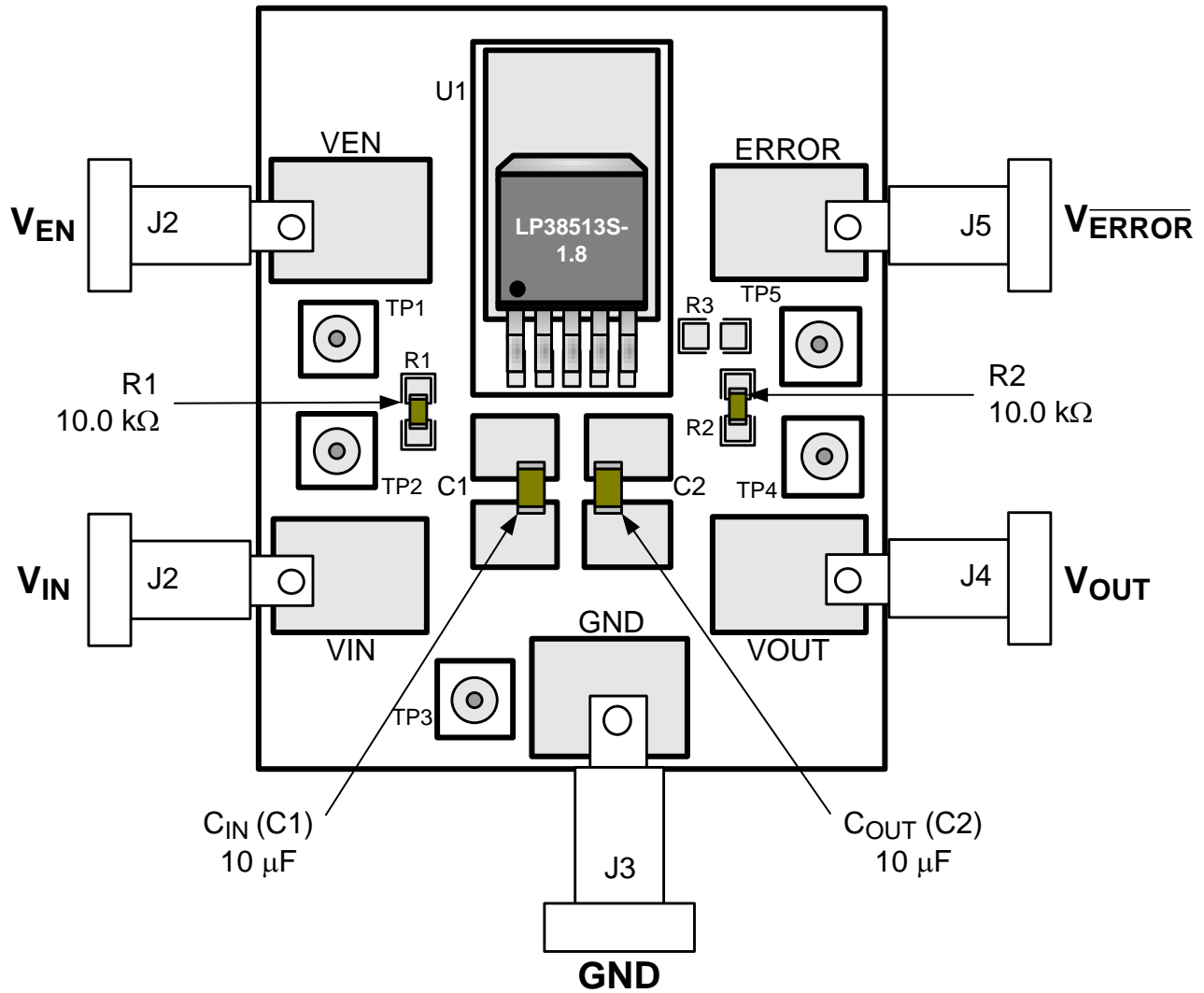

Figure 7. Evaluation Board Component and Pin Layout

10 Bill of Materials

ID	Name	Description	Manufacturer	Part Number
U1	U1	LP38513	Texas Instruments	LP38513
C1	C _{IN}	10 μ F, 10%, MLCC, 10V, X7R, 1210	AVX	1210ZC106KAT2A
C2	C _{OUT}	10 μ F, 10%, MLCC, 10V, X7R, 1210	AXV	1210ZC106KAT2A
J1	V _{EN}	Banana Jack : Insulated Solder Terminal ; White	Johnson Components	108-0901-001
J2	V _{IN}	Banana Jack : Insulated Solder Terminal ; Red		108-0902-001
J3	GND	Banana Jack : Insulated Solder Terminal ; Black		108-0903-001
J4	V _{OUT}	Banana Jack : Insulated Solder Terminal ; Orange		108-0906-001
J5	V _{ERR}	Banana Jack : Insulated Solder Terminal ; Blue		108-0910-001
R1	—	Resistor: 10 k Ω \pm 1%; 0805	Vishay Dale	CRCW 0805 1002 F
R2	—	Resistor: 10 k Ω \pm 1%; 0805	Vishay Dale	CRCW 0805 1002 F
R3	—	Not Installed	N/A	N/A
TP1	TP _{EN}	Turret Terminal : Mounting Hole Diameter = 0.062"	Keystone	1593-2
TP2	TP _{IN}			
TP3	TP _{GND}			
TP4	TP _{OUT}			
TP5	TP _{BIAS}			

IMPORTANT NOTICE

Texas Instruments Incorporated and its subsidiaries (TI) reserve the right to make corrections, enhancements, improvements and other changes to its semiconductor products and services per JESD46, latest issue, and to discontinue any product or service per JESD48, latest issue. Buyers should obtain the latest relevant information before placing orders and should verify that such information is current and complete. All semiconductor products (also referred to herein as "components") are sold subject to TI's terms and conditions of sale supplied at the time of order acknowledgment.

TI warrants performance of its components to the specifications applicable at the time of sale, in accordance with the warranty in TI's terms and conditions of sale of semiconductor products. Testing and other quality control techniques are used to the extent TI deems necessary to support this warranty. Except where mandated by applicable law, testing of all parameters of each component is not necessarily performed.

TI assumes no liability for applications assistance or the design of Buyers' products. Buyers are responsible for their products and applications using TI components. To minimize the risks associated with Buyers' products and applications, Buyers should provide adequate design and operating safeguards.

TI does not warrant or represent that any license, either express or implied, is granted under any patent right, copyright, mask work right, or other intellectual property right relating to any combination, machine, or process in which TI components or services are used. Information published by TI regarding third-party products or services does not constitute a license to use such products or services or a warranty or endorsement thereof. Use of such information may require a license from a third party under the patents or other intellectual property of the third party, or a license from TI under the patents or other intellectual property of TI.

Reproduction of significant portions of TI information in TI data books or data sheets is permissible only if reproduction is without alteration and is accompanied by all associated warranties, conditions, limitations, and notices. TI is not responsible or liable for such altered documentation. Information of third parties may be subject to additional restrictions.

Resale of TI components or services with statements different from or beyond the parameters stated by TI for that component or service voids all express and any implied warranties for the associated TI component or service and is an unfair and deceptive business practice. TI is not responsible or liable for any such statements.

Buyer acknowledges and agrees that it is solely responsible for compliance with all legal, regulatory and safety-related requirements concerning its products, and any use of TI components in its applications, notwithstanding any applications-related information or support that may be provided by TI. Buyer represents and agrees that it has all the necessary expertise to create and implement safeguards which anticipate dangerous consequences of failures, monitor failures and their consequences, lessen the likelihood of failures that might cause harm and take appropriate remedial actions. Buyer will fully indemnify TI and its representatives against any damages arising out of the use of any TI components in safety-critical applications.

In some cases, TI components may be promoted specifically to facilitate safety-related applications. With such components, TI's goal is to help enable customers to design and create their own end-product solutions that meet applicable functional safety standards and requirements. Nonetheless, such components are subject to these terms.

No TI components are authorized for use in FDA Class III (or similar life-critical medical equipment) unless authorized officers of the parties have executed a special agreement specifically governing such use.

Only those TI components which TI has specifically designated as military grade or "enhanced plastic" are designed and intended for use in military/aerospace applications or environments. Buyer acknowledges and agrees that any military or aerospace use of TI components which have **not** been so designated is solely at the Buyer's risk, and that Buyer is solely responsible for compliance with all legal and regulatory requirements in connection with such use.

TI has specifically designated certain components as meeting ISO/TS16949 requirements, mainly for automotive use. In any case of use of non-designated products, TI will not be responsible for any failure to meet ISO/TS16949.

Products

Audio	www.ti.com/audio
Amplifiers	amplifier.ti.com
Data Converters	dataconverter.ti.com
DLP® Products	www.dlp.com
DSP	dsp.ti.com
Clocks and Timers	www.ti.com/clocks
Interface	interface.ti.com
Logic	logic.ti.com
Power Mgmt	power.ti.com
Microcontrollers	microcontroller.ti.com
RFID	www.ti-rfid.com
OMAP Applications Processors	www.ti.com/omap
Wireless Connectivity	www.ti.com/wirelessconnectivity

Applications

Automotive and Transportation	www.ti.com/automotive
Communications and Telecom	www.ti.com/communications
Computers and Peripherals	www.ti.com/computers
Consumer Electronics	www.ti.com/consumer-apps
Energy and Lighting	www.ti.com/energy
Industrial	www.ti.com/industrial
Medical	www.ti.com/medical
Security	www.ti.com/security
Space, Avionics and Defense	www.ti.com/space-avionics-defense
Video and Imaging	www.ti.com/video

TI E2E Community

e2e.ti.com

Looking for pricing, stock, or lifecycle information?

Click below to explore more details on WIN SOURCE:

 [View LP38513S-1.8EV](#) on WIN SOURCE

 [Texas Instruments](#) Information

Optimize Your Supply Chain with WIN SOURCE Solutions

-  Global Sourcing Solution
-  Obsolete Management
-  Cost Control Management
-  Shortage Management
-  Alternative Solution
-  Excess Inventory Management