



**THE DATASHEET OF
LMZ30606EVM-003**



LMZ30606 6A Power Module with 2.95V-6V Input in QFN Package

1 Features

- Complete Integrated Power Solution Allows Small Footprint, Low-Profile Design
- 9mm x 11mm x 2.8mm package
 - Pin Compatible with LMZ30602 & LMZ30604
- Efficiencies Up To 96%
- Wide-Output Voltage Adjust
0.8 V to 3.6 V, with $\pm 1\%$ Reference Accuracy
- Adjustable Switching Frequency
(500 kHz to 2 MHz)
- Synchronizes to an External Clock
- Adjustable Slow-Start
- Output Voltage Sequencing / Tracking
- Power Good Output
- Programmable Undervoltage Lockout (UVLO)
- Output Overcurrent Protection
- Over Temperature Protection
- Operating Temperature Range: -40°C to 85°C
- Enhanced Thermal Performance: 12°C/W
- Meets EN55022 Class B Emissions
 - Integrated Shielded Inductor
- Create a Custom Design Using the LMZ30606 With the [WEBENCH® Power Designer](#)

2 Applications

- Broadband and Communications Infrastructure
- Automated Test and Medical Equipment
- Compact PCI / PCI Express / PXI Express
- DSP and FPGA Point of Load Applications
- High Density Distributed Power Systems

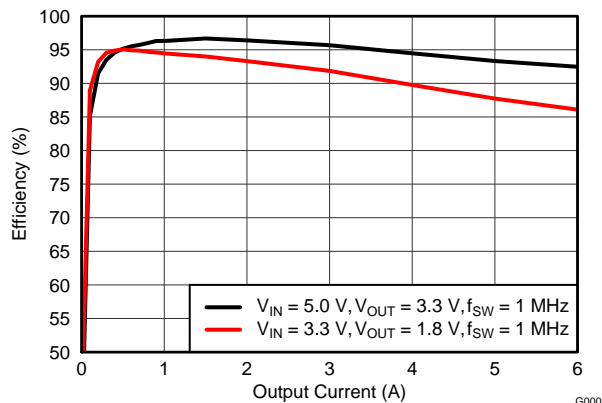

3 Description

The LMZ30606 SIMPLE SWITCHER® power module is an easy-to-use integrated power solution that combines a 6-A DC/DC converter with power MOSFETs, a shielded inductor, and passives into a low profile, QFN package. This total power solution requires as few as 3 external components and eliminates the loop compensation and magnetics part selection process.

The 9x11x2.8 mm QFN package is easy to solder onto a printed circuit board and allows a compact point-of-load design with greater than 90% efficiency and excellent power dissipation with a thermal impedance of 12°C/W junction to ambient. The device delivers the full 6-A rated output current at 85°C ambient temperature without airflow.

The LMZ30606 offers the flexibility and the feature-set of a discrete point-of-load design and is ideal for powering performance DSPs and FPGAs. Advanced packaging technology afford a robust and reliable power solution compatible with standard QFN mounting and testing techniques.

Simplified Application

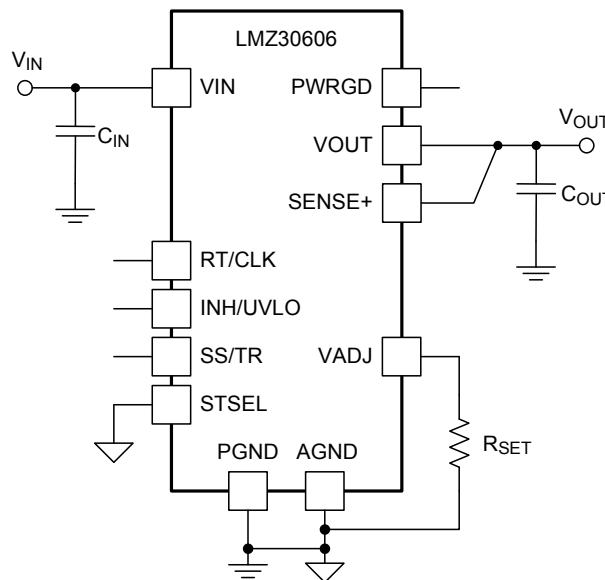

Table 1. Ordering Information

For the most current package and ordering information, see the Package Option Addendum at the end of this datasheet, or see the TI website at www.ti.com.

4 Specifications

4.1 Absolute Maximum Ratings⁽¹⁾

over operating temperature range (unless otherwise noted)

		VALUE		UNIT
		MIN	MAX	
Input Voltage	VIN, PWRGD	-0.3	7	V
	INH/UVLO, RT/CLK	-0.3	3.3	V
	SS/TR, STSEL, VADJ	-0.3	3	V
	SENSE+ VADJ rating must also be met	-0.3	V _{OUT}	V
Output Voltage	PH	-0.6	7	V
	PH 10 ns, transient	-2	7	V
	VOUT	-0.6	VIN	V
V _{DIFF} (GND to exposed thermal pad)		-0.2	0.2	V
Source Current	RT/CLK, INH/UVLO	±100		µA
	PH	Current Limit		A
Sink Current	PH	Current Limit		A
	SS/TR	±100		µA
	PWRGD	10		mA
	Operating Junction Temperature	-40	125 ⁽²⁾	°C
Storage Temperature, T _{stg}		-65	150	°C
Peak Reflow Case Temperature ⁽³⁾		250 ⁽⁴⁾		°C
Maximum Number of Reflows Allowed ⁽³⁾		3 ⁽⁴⁾		
Mechanical Shock	Mil-STD-883D, Method 2002.3, 1 msec, 1/2 sine, mounted	1500		G
Mechanical Vibration	Mil-STD-883D, Method 2007.2, 20-2000Hz	20		

- (1) Stresses beyond those listed under absolute maximum ratings may cause permanent damage to the device. These are stress ratings only, and functional operation of the device at these or any other conditions beyond those indicated under recommended operating conditions is not implied. Exposure to absolute-maximum-rated conditions for extended periods may affect device reliability.
- (2) See the temperature derating curves in the Typical Characteristics section for thermal information.
- (3) For soldering specifications, refer to the [Soldering Requirements for BQFN Packages](#) application note.
- (4) Devices with a date code prior to week 14 2018 (1814) have a peak reflow case temperature of 240°C with a maximum of one reflow.

4.2 Thermal Information

THERMAL METRIC ⁽¹⁾		LMZ30606	UNIT
		RKG39	
		39 PINS	
θ _{JA}	Junction-to-ambient thermal resistance ⁽²⁾	12	°C/W
ψ _{JT}	Junction-to-top characterization parameter ⁽³⁾	2.2	
ψ _{JB}	Junction-to-board characterization parameter ⁽⁴⁾	9.7	

- (1) For more information about traditional and new thermal metrics, see the [Semiconductor and IC Package Thermal Metrics](#) (SPRA953) application report.
- (2) The junction-to-ambient thermal resistance, θ_{JA}, applies to devices soldered directly to a 100 mm x 100 mm double-sided PCB with 1 oz. copper and natural convection cooling. Additional airflow reduces θ_{JA}.
- (3) The junction-to-top characterization parameter, ψ_{JT}, estimates the junction temperature, T_J, of a device in a real system, using a procedure described in JESD51-2A (sections 6 and 7). T_J = ψ_{JT} * P_{dis} + T_T; where P_{dis} is the power dissipated in the device and T_T is the temperature of the top of the device.
- (4) The junction-to-board characterization parameter, ψ_{JB}, estimates the junction temperature, T_J, of a device in a real system, using a procedure described in JESD51-2A (sections 6 and 7). T_J = ψ_{JB} * P_{dis} + T_B; where P_{dis} is the power dissipated in the device and T_B is the temperature of the board 1mm from the device.

Electrical Characteristics (continued)

Over -40°C to 85°C free-air temperature, $V_{\text{IN}} = 3.3\text{ V}$, $V_{\text{OUT}} = 1.8\text{ V}$, $I_{\text{OUT}} = 6\text{ A}$,
 $C_{\text{IN}1} = 47\text{ }\mu\text{F}$ ceramic, $C_{\text{IN}2} = 220\text{ }\mu\text{F}$ poly-tantalum, $C_{\text{OUT}1} = 47\text{ }\mu\text{F}$ ceramic, $C_{\text{OUT}2} = 100\text{ }\mu\text{F}$ poly-tantalum (unless otherwise noted)

PARAMETER		TEST CONDITIONS	MIN	TYP	MAX	UNIT
C_{IN}	External input capacitance	Ceramic	47 ⁽⁵⁾			μF
		Non-ceramic		220 ⁽⁵⁾		
C_{OUT}	External output capacitance	Ceramic	47 ⁽⁶⁾	150	650 ⁽⁷⁾	μF
		Non-ceramic		100 ⁽⁶⁾	2000 ⁽⁷⁾	
		Equivalent series resistance (ESR)				25

- (5) A minimum of $47\mu\text{F}$ of ceramic capacitance is required across the input for proper operation. Locate the capacitor close to the device. An additional $220\mu\text{F}$ of bulk capacitance is recommended. See [Table 6](#) for more details.
- (6) The amount of required output capacitance varies depending on the output voltage (see [Table 5](#)). The amount of required capacitance must include at least $47\mu\text{F}$ of ceramic capacitance. Locate the capacitance close to the device. Adding additional capacitance close to the load improves the response of the regulator to load transients. See [Table 5](#) and [Table 6](#) for more details.
- (7) When using both ceramic and non-ceramic output capacitance, the combined maximum must not exceed $2200\mu\text{F}$.

4.4 Package Specifications

LMZ30606		UNIT
Weight		0.85 grams
Flammability	Meets UL 94 V-O	
MTBF Calculated reliability	Per Bellcore TR-332, 50% stress, $T_A = 40^{\circ}\text{C}$, ground benign	32.8 Mhrs

5 Device Information

FUNCTIONAL BLOCK DIAGRAM

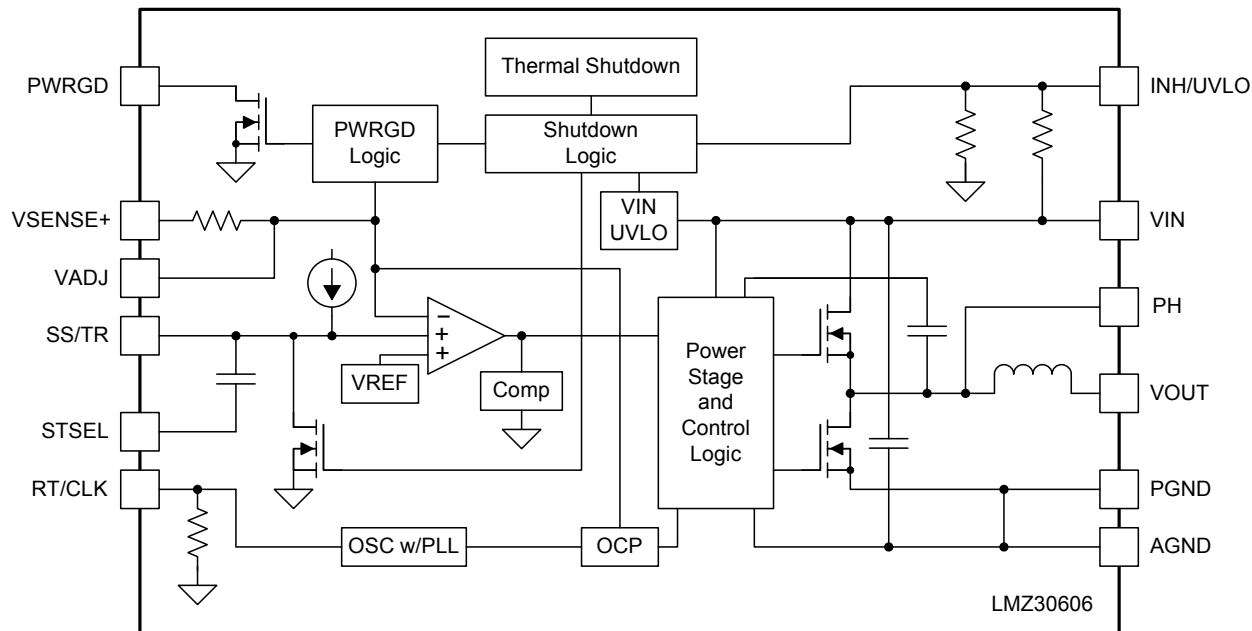
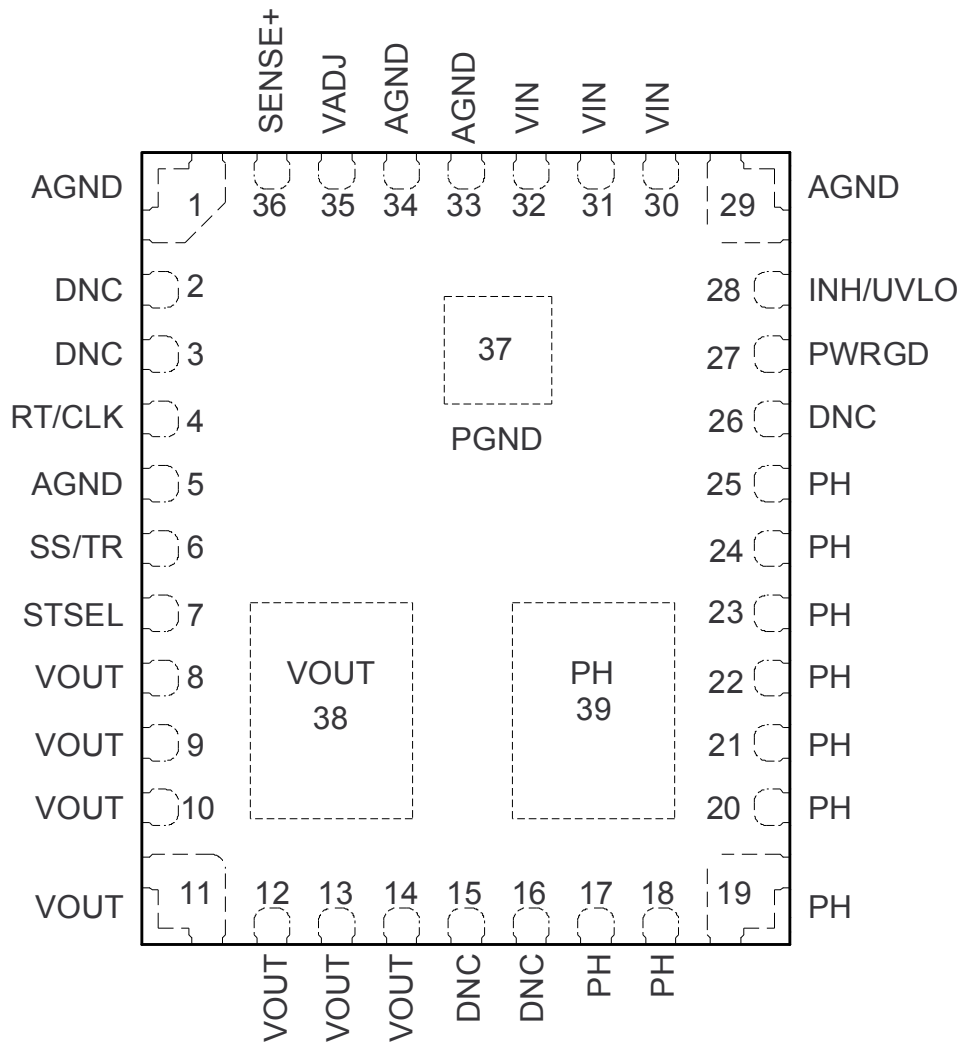

Table 2. PIN DESCRIPTIONS

TERMINAL		DESCRIPTION
NAME	NO.	
AGND	1	Zero VDC reference for the analog control circuitry. These pins should be connected directly to the PCB analog ground plane. Not all pins are connected together internally. All pins must be connected together externally with a copper plane or pour directly under the module. Connect the AGND copper area to the PGND copper area at a single point; directly at the pin 37 PowerPAD using multiple vias. See the recommended layout in Figure 36 .
	5	
	29	
	33	
	34	
PowerPAD (PGND)	37	This pad provides both an electrical and thermal connection to the PCB. This pad should be connected directly to the PCB power ground plane using multiple vias for good electrical and thermal performance. The same vias should also be used to connect to the PCB analog ground plane. See the recommended layout in Figure 36 .
DNC	2	Do Not Connect. Do not connect these pins to AGND, to another DNC pin, or to any other voltage. These pins are connected to internal circuitry. Each pin must be soldered to an isolated pad.
	3	
	15	
	16	
	26	
INH/UVLO	28	Inhibit and UVLO adjust pin. Use an open drain or open collector output logic to control the INH function. A resistor between this pin and AGND adjusts the UVLO voltage.
PH	17	Phase switch node. These pins should be connected by a small copper island under the device for thermal relief. Do not connect any external component to this pin or tie it to a pin of another function.
	18	
	19	
	20	
	21	
	22	
	23	
	24	
	25	
39		
PWRGD	27	Power good fault pin. Asserts low if the output voltage is out of tolerance. A pull-up resistor is required.
RT/CLK	4	This pin automatically selects between RT mode and CLK mode. An external timing resistor adjusts the switching frequency of the device. In CLK mode, the device synchronizes to an external clock.
SENSE+	36	Remote sense connection. Connect this pin to VOUT at the load for improved regulation. This pin must be connected to VOUT at the load, or at the module pins.
SS/TR	6	Slow-start and tracking pin. Connecting an external capacitor to this pin adjusts the output voltage rise time. A voltage applied to this pin allows for tracking and sequencing control.
STSEL	7	Slow-start or track feature select. Connect this pin to AGND to enable the internal SS capacitor with a SS interval of approximately 1.1 ms. Leave this pin open to enable the TR feature.
VADJ	35	Connecting a resistor between this pin and AGND sets the output voltage above the 0.8V default voltage.
VIN	30	The positive input voltage power pins, which are referenced to PGND. Connect external input capacitance between these pins and the PGND plane, close to the device.
	31	
	32	
VOUT	8	Output voltage. Connect output capacitors between these pins and the PGND plane, close to the device.
	9	
	10	
	11	
	12	
	13	
	14	
	38	

RKG PACKAGE
39 PINS
(TOP VIEW)



6 Typical Characteristics (VIN = 5 V)

The electrical characteristic data has been developed from actual products tested at 25°C. This data is considered typical for the converter. Applies to [Figure 1](#), [Figure 2](#), and [Figure 3](#). The temperature derating curves represent the conditions at which internal components are at or below the manufacturer's maximum operating temperatures. Derating limits apply to devices soldered directly to a 100 mm × 100 mm double-sided PCB with 1 oz. copper. Applies to [Figure 4](#).

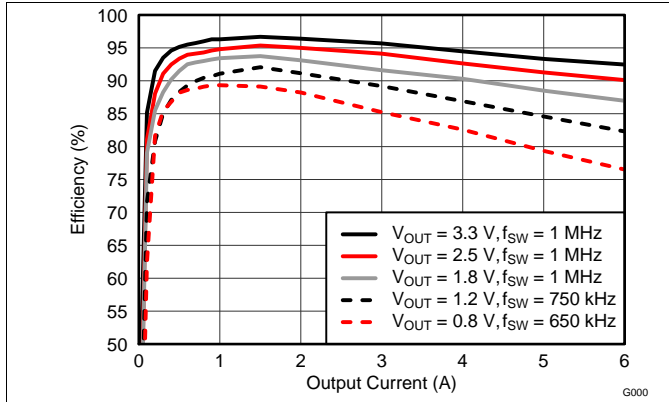

Figure 1. Efficiency vs. Output Current

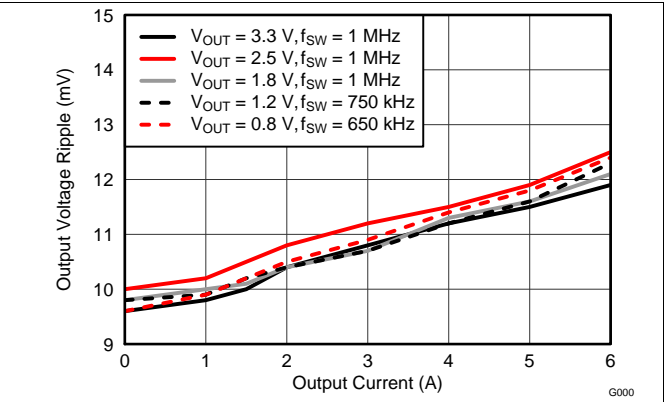

Figure 2. Voltage Ripple vs. Output Current

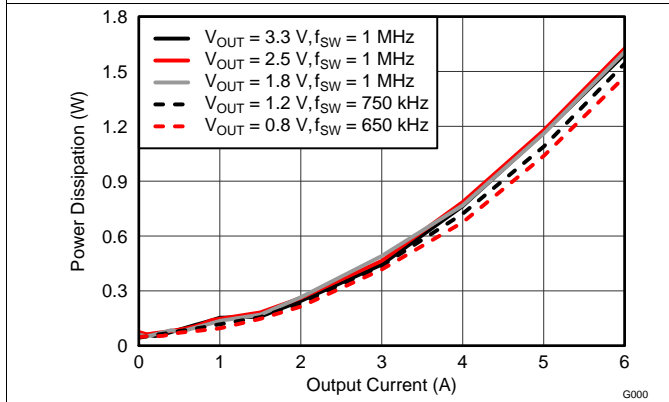

Figure 3. Power Dissipation vs. Output Current

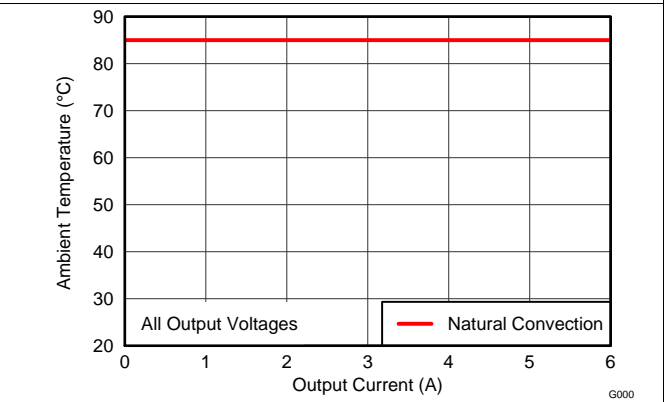

Figure 4. Safe Operating Area

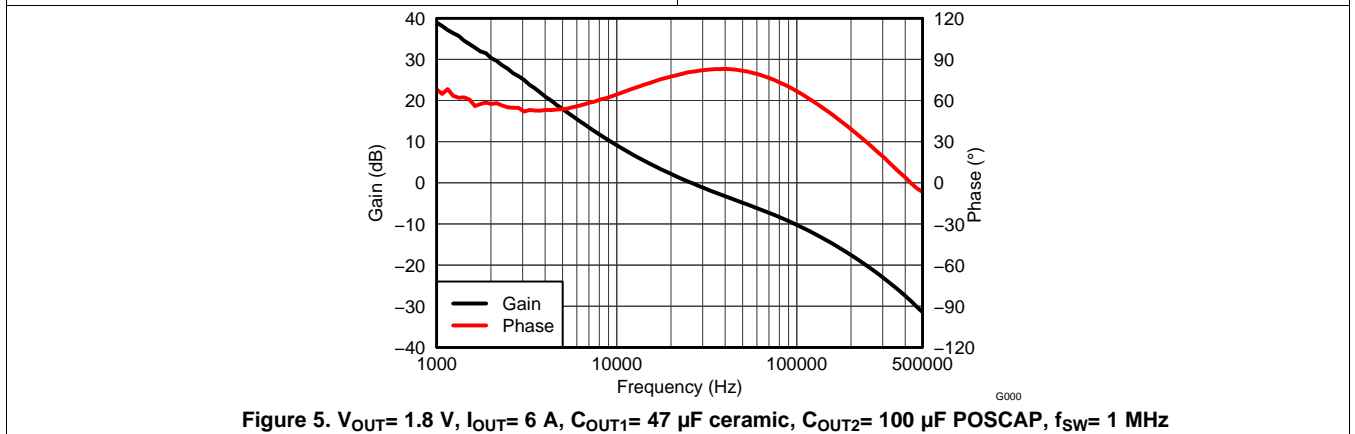

Figure 5. $V_{OUT} = 1.8\text{ V}$, $I_{OUT} = 6\text{ A}$, $C_{OUT1} = 47\text{ }\mu\text{F}$ ceramic, $C_{OUT2} = 100\text{ }\mu\text{F}$ POSCAP, $f_{SW} = 1\text{ MHz}$

7 Typical Characteristics (VIN = 3.3 V)

The electrical characteristic data has been developed from actual products tested at 25°C. This data is considered typical for the converter. Applies to Figure 6, Figure 7, and Figure 8. The temperature derating curves represent the conditions at which internal components are at or below the manufacturer's maximum operating temperatures. Derating limits apply to devices soldered directly to a 100 mm × 100 mm double-sided PCB with 1 oz. copper. Applies to Figure 9.

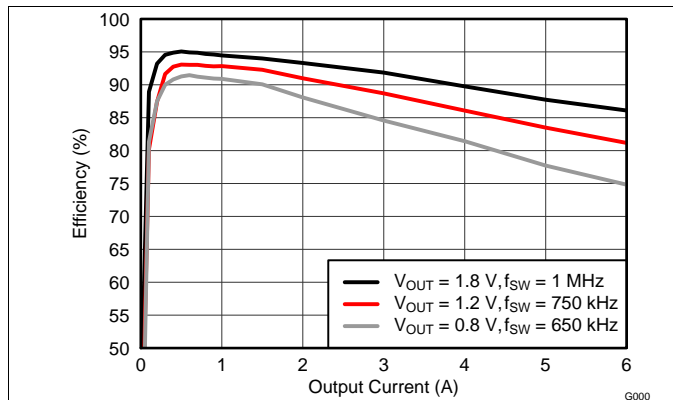

Figure 6. Efficiency vs. Output Current

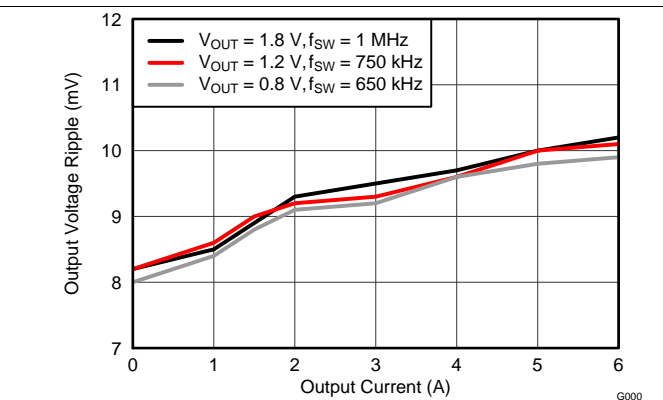

Figure 7. Voltage Ripple vs. Output Current

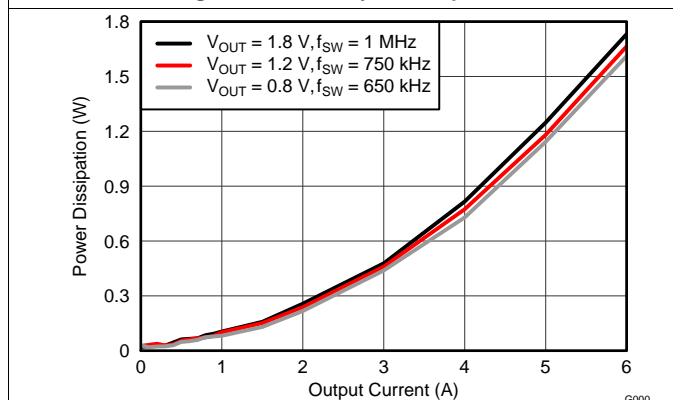

Figure 8. Power Dissipation vs. Output Current

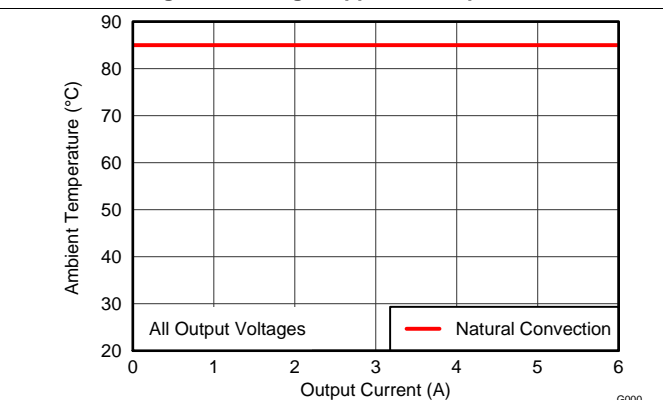

Figure 9. Safe Operating Area

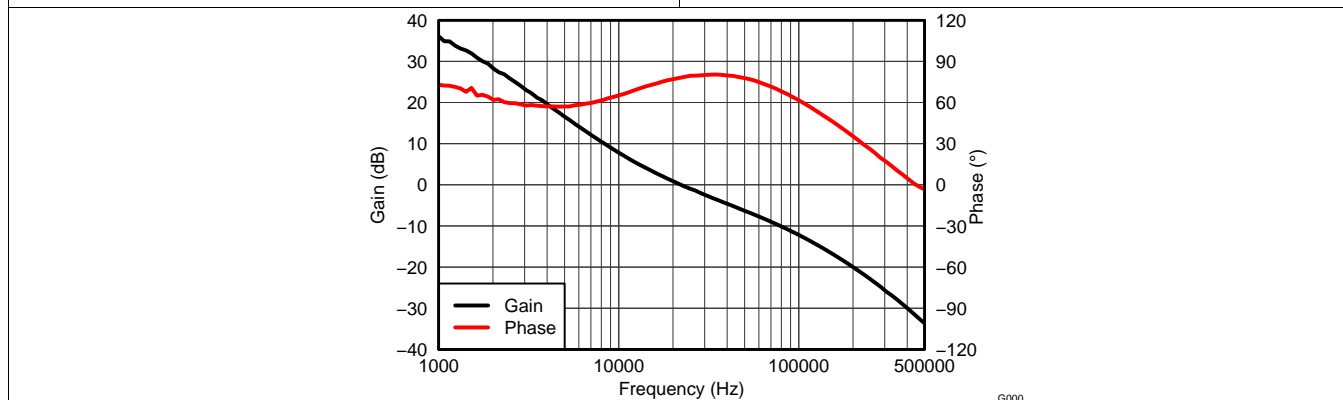

Figure 10. V_{OUT} = 1.8 V, I_{OUT} = 6 A, C_{OUT1} = 47 μF ceramic, C_{OUT2} = 100 μF POSCAP, f_{SW} = 1 MHz

8 Application Information

8.1 Adjusting the Output Voltage

The VADJ control sets the output voltage of the LMZ30606. The output voltage adjustment range is from 0.8V to 3.6V. The adjustment method requires the addition of R_{SET} , which sets the output voltage, the connection of SENSE+ to VOUT, and in some cases R_{RT} which sets the switching frequency. The R_{SET} resistor must be connected directly between the VADJ (pin 35) and AGND (pin 33 & 34). The SENSE+ pin (pin 36) must be connected to VOUT either at the load for improved regulation or at VOUT of the module. The R_{RT} resistor must be connected directly between the RT/CLK (pin 4) and AGND (pins 33 & 34).

[Table 3](#) gives the standard external R_{SET} resistor for a number of common bus voltages, along with the recommended R_{RT} resistor for that output voltage.

Table 3. Standard R_{SET} Resistor Values for Common Output Voltages

RESISTORS	OUTPUT VOLTAGE V_{OUT} (V)					
	0.8	1.2	1.5	1.8	2.5	3.3
R_{SET} (k Ω)	open	2.87	1.65	1.15	0.673	0.459
R_{RT} (k Ω)	1200	715	348	348	348	348

For other output voltages, the value of the required resistor can either be calculated using the following formula, or simply selected from the range of values given in [Table 4](#).

$$R_{SET} = \frac{1.43}{\left(\left(\frac{V_{OUT}}{0.799}\right) - 1\right)} \text{ (k}\Omega\text{)}$$

(1)

Table 4. Standard R_{SET} Resistor Values

V_{OUT} (V)	R_{SET} (k Ω)	R_{RT} (k Ω)	f_{SW} (kHz)	V_{OUT} (V)	R_{SET} (k Ω)	R_{RT} (k Ω)	f_{SW} (kHz)
0.8	open	1200	650	2.3	0.768	348	1000
0.9	11.8	1200	650	2.4	0.715	348	1000
1.0	5.83	1200	650	2.5	0.673	348	1000
1.1	3.83	1200	650	2.6	0.634	348	1000
1.2	2.87	715	750	2.7	0.604	348	1000
1.3	2.32	715	750	2.8	0.576	348	1000
1.4	1.91	715	750	2.9	0.549	348	1000
1.5	1.65	348	1000	3.0	0.523	348	1000
1.6	1.43	348	1000	3.1	0.499	348	1000
1.7	1.27	348	1000	3.2	0.475	348	1000
1.8	1.15	348	1000	3.3	0.459	348	1000
1.9	1.05	348	1000	3.4	0.442	348	1000
2.0	0.953	348	1000	3.5	0.422	348	1000
2.1	0.845	348	1000	3.6	0.412	348	1000
2.2	0.825	348	1000				

8.2 Capacitor Recommendations for the LMZ30606 Power Supply

8.2.1 Capacitor Technologies

8.2.1.1 Electrolytic, Polymer-Electrolytic Capacitors

When using electrolytic capacitors, high-quality, computer-grade electrolytic capacitors are recommended. Polymer-electrolytic type capacitors are recommended for applications where the ambient operating temperature is less than 0°C. The Sanyo OS-CON capacitor series is suggested due to the lower ESR, higher rated surge, power dissipation, ripple current capability, and small package size. Aluminum electrolytic capacitors provide adequate decoupling over the frequency range of 2 kHz to 150 kHz, and are suitable when ambient temperatures are above 0°C.

8.2.1.2 Ceramic Capacitors

The performance of aluminum electrolytic capacitors is less effective than ceramic capacitors above 150 kHz. Multilayer ceramic capacitors have a low ESR and a resonant frequency higher than the bandwidth of the regulator. They can be used to reduce the reflected ripple current at the input as well as improve the transient response of the output.

8.2.1.3 Tantalum, Polymer-Tantalum Capacitors

Polymer-tantalum type capacitors are recommended for applications where the ambient operating temperature is less than 0°C. The Sanyo POSCAP series and Kemet T530 capacitor series are recommended rather than many other tantalum types due to their lower ESR, higher rated surge, power dissipation, ripple current capability, and small package size. Tantalum capacitors that have no stated ESR or surge current rating are not recommended for power applications.

8.2.2 Input Capacitor

The LMZ30606 requires a minimum input capacitance of 47 μF of ceramic capacitance. An additional 220 μF polymer-tantalum capacitor is recommended for applications with transient load requirements. The combined ripple current rating of the input capacitors must be at least 3000 mArms. [Table 6](#) includes a preferred list of capacitors by vendor. For applications where the ambient operating temperature is less than 0°C, an additional 1 μF , X5R or X7R ceramic capacitor placed between VIN and AGND is recommended.

8.2.3 Output Capacitor

The required output capacitance is determined by the output voltage of the LMZ30606. See [Table 5](#) for the amount of required capacitance. The required output capacitance must include at least one 47 μF ceramic capacitor. For applications where the ambient operating temperature is less than 0°C, an additional 100 μF polymer-tantalum capacitor is recommended. When adding additional non-ceramic bulk capacitors, low-ESR devices like the ones recommended in [Table 6](#) are required. The required capacitance above the minimum is determined by actual transient deviation requirements. See [Table 7](#) for typical transient response values for several output voltage, input voltage and capacitance combinations. [Table 6](#) includes a preferred list of capacitors by vendor.

Table 5. Required Output Capacitance

V _{OUT} RANGE (V)		MINIMUM REQUIRED C _{OUT} (μF)
MIN	MAX	
0.8	< 1.8	147 ⁽¹⁾
1.8	< 3.3	100 ⁽²⁾
3.3	3.6	47 ⁽²⁾

- (1) Minimum required must include at least 1 x 47 μF ceramic capacitor plus 1 x 100 μF polymer-tantalum capacitor.
- (2) Minimum required must include at least 47 μF of ceramic capacitance.

Table 6. Recommended Input/Output Capacitors⁽¹⁾

VENDOR	SERIES	PART NUMBER	CAPACITOR CHARACTERISTICS		
			WORKING VOLTAGE (V)	CAPACITANCE (μF)	ESR ⁽²⁾ (mΩ)
Murata	X5R	GRM32ER61C476K	16	47	2
TDK	X5R	C3225X5R0J107M	6.3	100	2
Murata	X5R	GRM32ER60J107M	6.3	100	2
TDK	X5R	C3225X5R0J476K	6.3	47	2
Murata	X5R	GRM32ER60J476M	6.3	47	2
Sanyo	POSCAP	10TPE220ML	10	220	25
Kemet	T520	T520V107M010ASE025	10	100	25
Sanyo	POSCAP	6TPE100MPB	6.3	100	25
Sanyo	POSCAP	2R5TPE220M7	2.5	220	7
Kemet	T530	T530D227M006ATE006	6.3	220	6
Kemet	T530	T530D337M006ATE010	6.3	330	10
Sanyo	POSCAP	2TPF330M6	2.0	330	6
Sanyo	POSCAP	6TPE330MFL	6.3	330	15

(1) Capacitor Supplier Verification

Please verify availability of capacitors identified in this table.

RoHS, Lead-free and Material Details

Please consult capacitor suppliers regarding material composition, RoHS status, lead-free status, and manufacturing process requirements.

(2) Maximum ESR @ 100kHz, 25°C.

8.3 Transient Response

Table 7. Output Voltage Transient Response

C _{IN1} = 1 x 47 μF CERAMIC, C _{IN2} = 220 μF POLYMER-TANTALUM						
V _{OUT} (V)	V _{IN} (V)	C _{OUT1} Ceramic	C _{OUT2} BULK	VOLTAGE DEVIATION (mV)		RECOVERY TIME (μs)
				2 A LOAD STEP, (1 A/μs)	3 A LOAD STEP, (1 A/μs)	
0.8	3.3	47 μF	330 μF	35	45	60
		47 μF	470 μF	30	40	60
	5	47 μF	330 μF	30	40	60
		47 μF	470 μF	25	35	60
1.2	3.3	47 μF	330 μF	45	65	60
		47 μF	470 μF	40	60	60
	5	47 μF	330 μF	40	65	60
		47 μF	470 μF	35	60	60
1.8	3.3	47 μF	220 μF	65	90	70
		47 μF	330 μF	60	85	70
	5	47 μF	220 μF	60	85	70
		47 μF	330 μF	50	75	70
2.5	5	3x 47 μF	-	95	150	70
		3x 47 μF	100 μF	85	125	70
3.3	5	3x 47 μF	-	120	180	70
		3x 47 μF	100 μF	100	150	70

8.3.1 Transient Waveforms

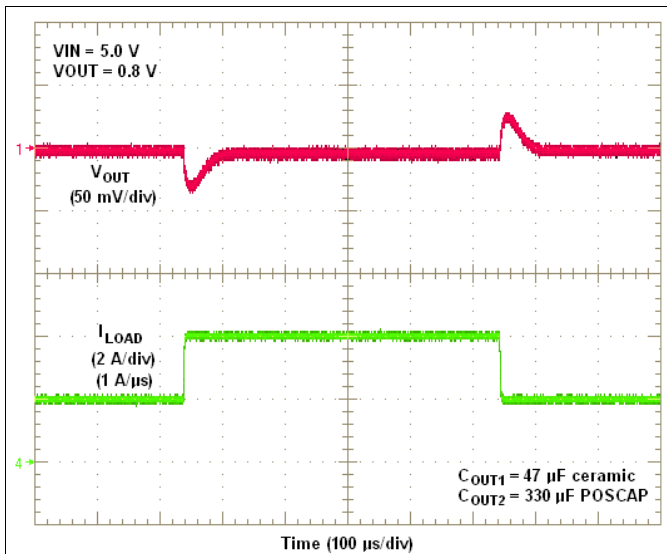

Figure 11. VIN = 5V, VOUT = 0.8V, 2A Load Step

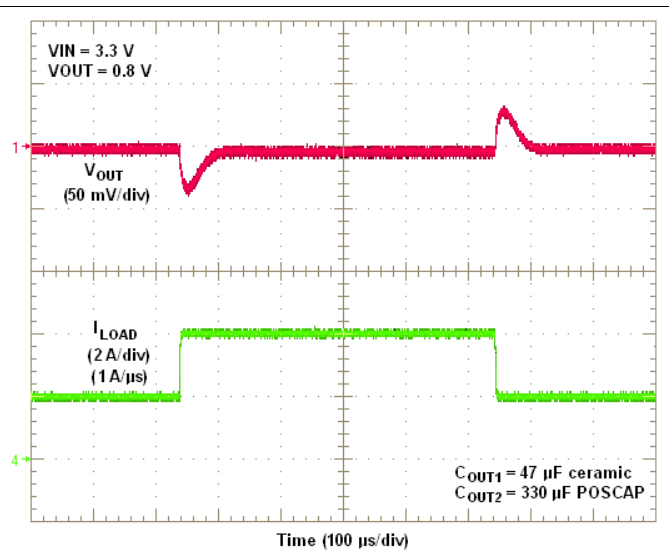

Figure 12. VIN = 3.3V, VOUT = 0.8V, 2A Load Step

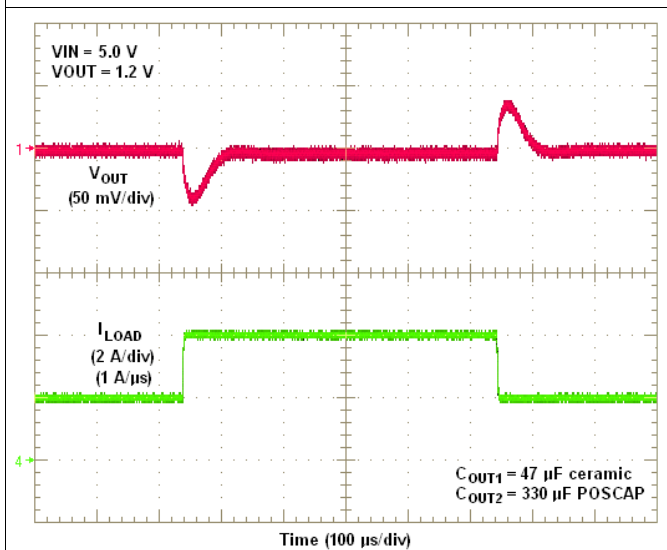

Figure 13. VIN = 5V, VOUT = 1.2V, 2A Load Step

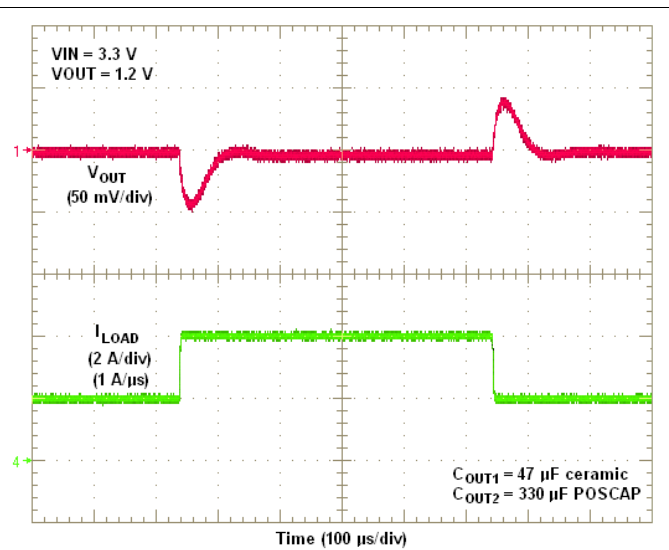
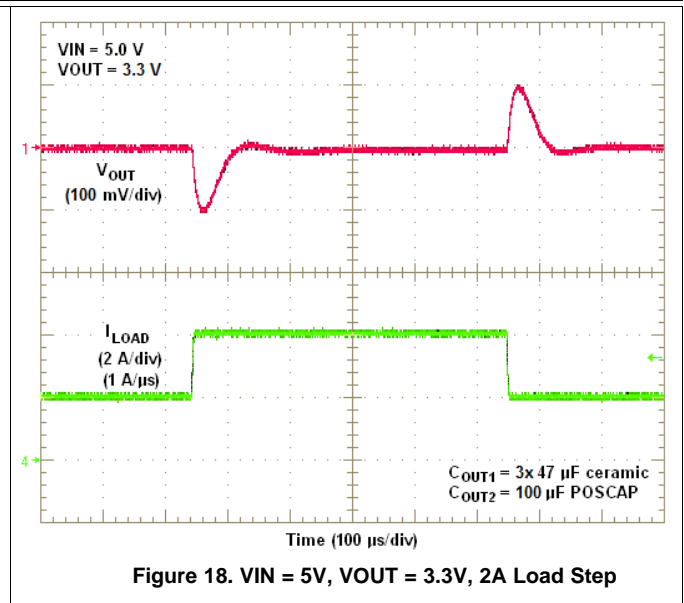
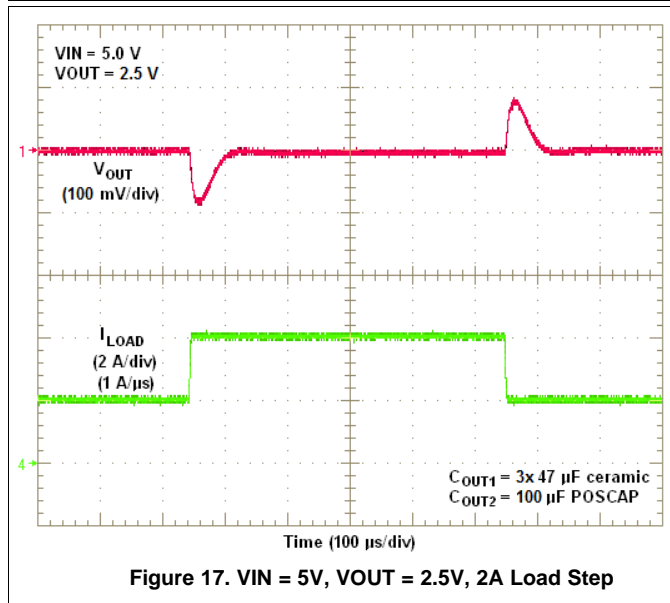
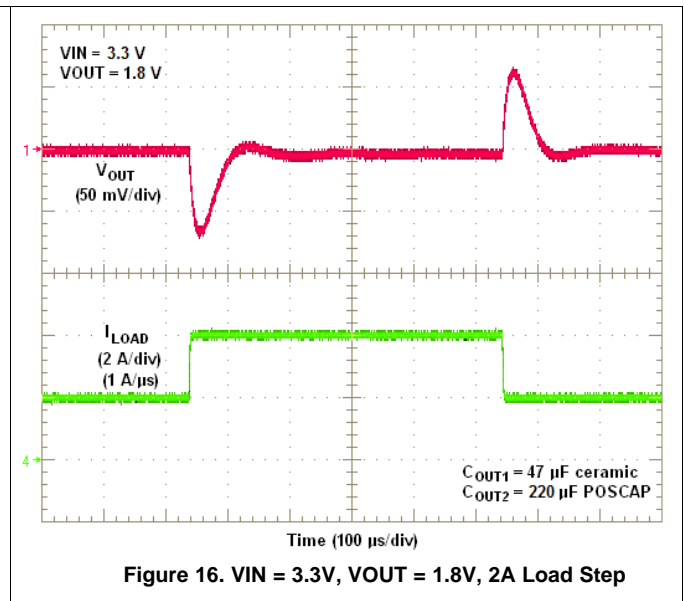
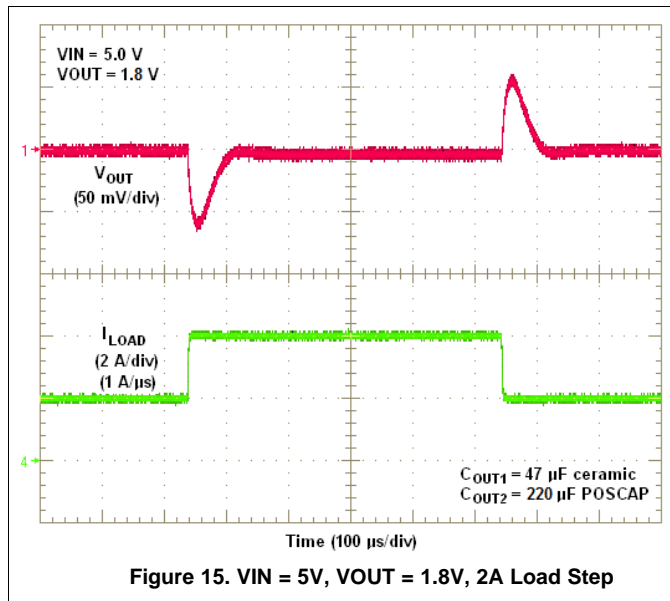

Figure 14. VIN = 3.3V, VOUT = 1.2V, 2A Load Step

LMZ30606

SNVS995B – JULY 2013 – REVISED APRIL 2018

www.ti.com



8.4 Application Schematics

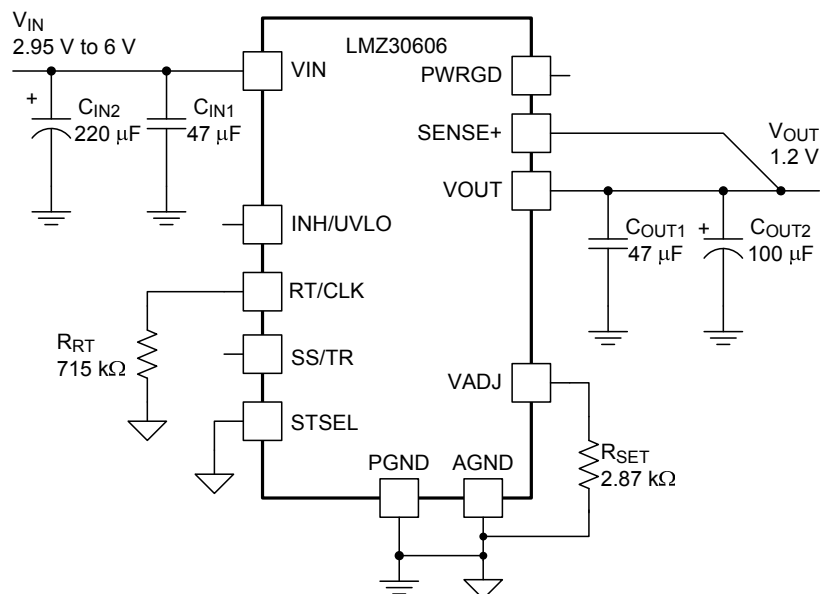

Figure 19. Typical Schematic
VIN = 2.95 V to 6.0 V, VOUT = 1.2 V

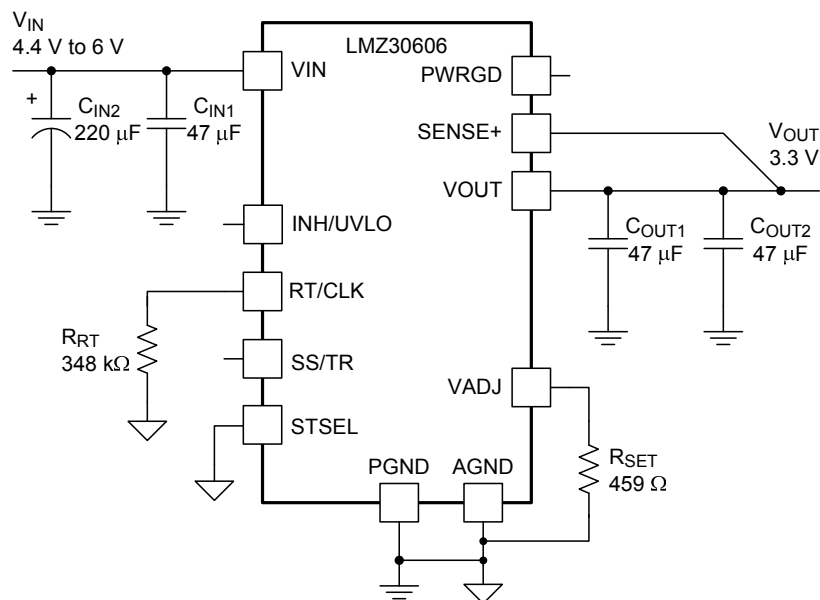

Figure 20. Typical Schematic
VIN = 4.4 V to 6.0 V, VOUT = 3.3 V

8.5 Custom Design With WEBENCH® Tools

[Click here](#) to create a custom design using the LMZ30606 device with the WEBENCH® Power Designer.

1. Start by entering the input voltage (V_{IN}), output voltage (V_{OUT}), and output current (I_{OUT}) requirements.
2. Optimize the design for key parameters such as efficiency, footprint, and cost using the optimizer dial.
3. Compare the generated design with other possible solutions from Texas Instruments.

The WEBENCH Power Designer provides a customized schematic along with a list of materials with real-time pricing and component availability.

In most cases, these actions are available:

- Run electrical simulations to see important waveforms and circuit performance
- Run thermal simulations to understand board thermal performance
- Export customized schematic and layout into popular CAD formats
- Print PDF reports for the design, and share the design with colleagues

Get more information about WEBENCH tools at www.ti.com/WEBENCH.

8.6 Power Good (PWRGD)

The PWRGD pin is an open drain output. Once the voltage on the SENSE+ pin is between 93% and 107% of the set voltage, the PWRGD pin pull-down is released and the pin floats. The recommended pull-up resistor value is between 10 k Ω and 100 k Ω to a voltage source that is 6 V or less. The PWRGD pin is in a defined state once V_{IN} is greater than 1.2 V, but with reduced current sinking capability. The PWRGD pin achieves full current sinking capability once the V_{IN} pin is above 2.95V. [Figure 21](#) shows the PWRGD waveform during power-up. The PWRGD pin is pulled low when the voltage on SENSE+ is lower than 91% or greater than 109% of the nominal set voltage. Also, the PWRGD pin is pulled low if the input UVLO or thermal shutdown is asserted, or if the INH pin is pulled low.

8.7 Power-Up Characteristics

When configured as shown in the front page schematic, the LMZ30606 produces a regulated output voltage following the application of a valid input voltage. During the power-up, internal soft-start circuitry slows the rate that the output voltage rises, thereby limiting the amount of in-rush current that can be drawn from the input source. The soft-start circuitry introduces a short time delay from the point that a valid input voltage is recognized. Figure 21 shows the start-up waveforms for a LMZ30606, operating from a 5-V input and with the output voltage adjusted to 1.8 V. The waveform is measured with a 3-A constant current load.

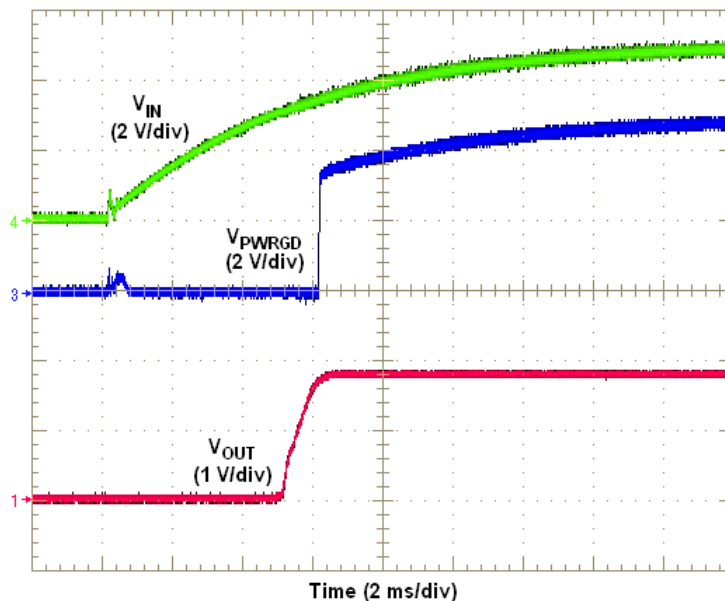

Figure 21. Start-Up Waveforms

8.8 Remote Sense

The SENSE+ pin must be connected to V_{OUT} at the load, or at the device pins.

Connecting the SENSE+ pin to V_{OUT} at the load improves the load regulation performance of the device by allowing it to compensate for any I-R voltage drop between its output pins and the load. An I-R drop is caused by the high output current flowing through the small amount of pin and trace resistance. This should be limited to a maximum of 300 mV.

NOTE

The remote sense feature is not designed to compensate for the forward drop of nonlinear or frequency dependent components that may be placed in series with the converter output. Examples include OR-ing diodes, filter inductors, ferrite beads, and fuses. When these components are enclosed by the SENSE+ connection, they are effectively placed inside the regulation control loop, which can adversely affect the stability of the regulator.

8.9 Output On/Off Inhibit (INH)

The INH pin provides electrical on/off control of the device. Once the INH pin voltage exceeds the threshold voltage, the device starts operation. If the INH pin voltage is pulled below the threshold voltage, the regulator stops switching and enters low quiescent current state.

The INH pin has an internal pull-up current source, allowing the user to float the INH pin for enabling the device. If an application requires controlling the INH pin, use an open drain/collector device, or a suitable logic gate to interface with the pin. Do not place an external pull-up resistor on this pin. Figure 22 shows the typical application of the inhibit function.

Turning Q1 on applies a low voltage to the inhibit control (INH) pin and disables the output of the supply, as shown in Figure 23. If Q1 is turned off, the supply executes a soft-start power-up sequence, as shown in Figure 24. The waveforms were measured with a 3-A constant current load.

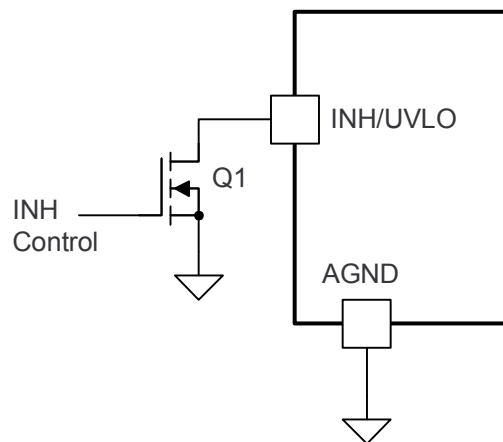
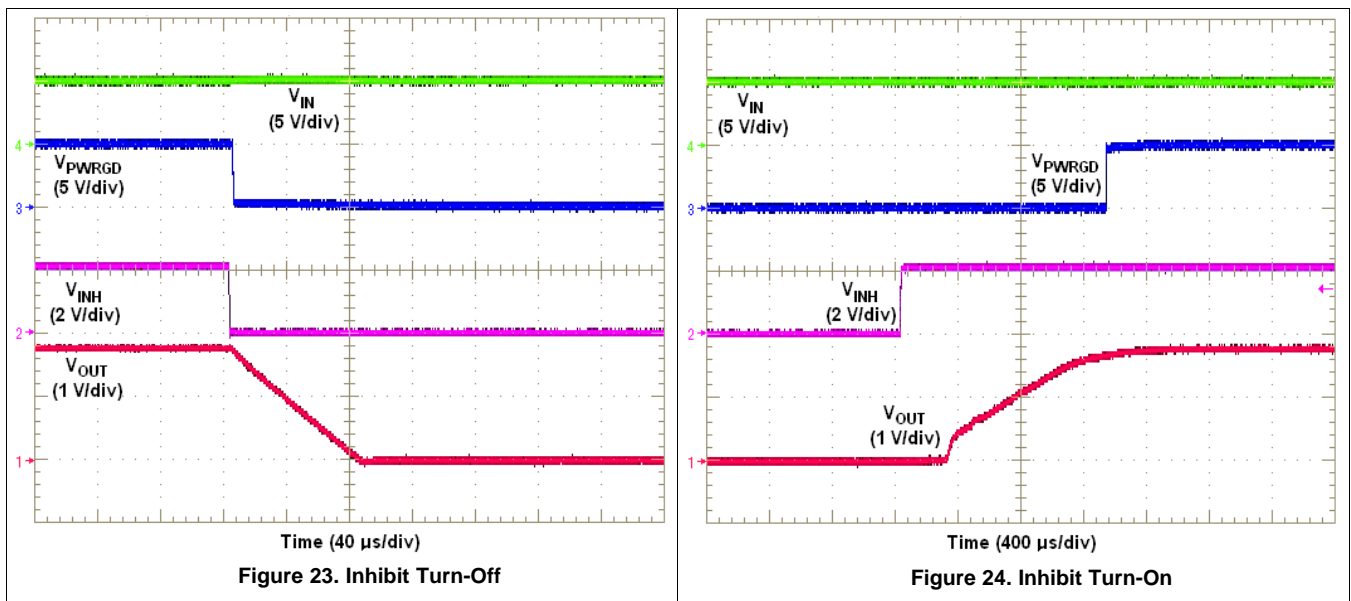

Figure 22. Typical Inhibit Control



8.10 Slow Start (SS/TR)

Connecting the STSEL pin to AGND and leaving SS/TR pin open enables the internal SS capacitor with a slow start interval of approximately 1.1 ms. Adding additional capacitance between the SS pin and AGND increases the slow start time. Table 8 shows an additional SS capacitor connected to the SS/TR pin and the STSEL pin connected to AGND. See Table 8 below for SS capacitor values and timing interval.

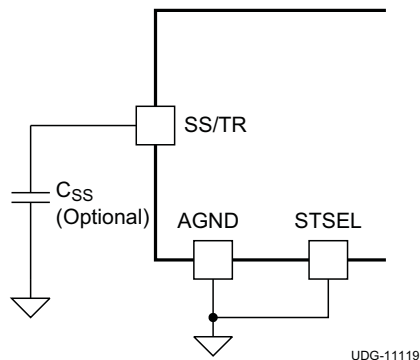

Figure 25. Slow-Start Capacitor (C_{SS}) and STSEL Connection

Table 8. Slow-Start Capacitor Values and Slow-Start Time

C_{SS} (pF)	open	2200	4700	10000	15000	22000	25000
SS Time (msec)	1.1	1.9	2.8	4.6	6.4	8.8	9.8

8.11 Overcurrent Protection

For protection against load faults, the LMZ30606 uses current limiting. The device is protected from overcurrent conditions by cycle-by-cycle current limiting and frequency foldback. During an overcurrent condition the output current is limited and the output voltage is reduced, as shown in Figure 26. When the overcurrent condition is removed, the output voltage returns to the established voltage, as shown in Figure 27.

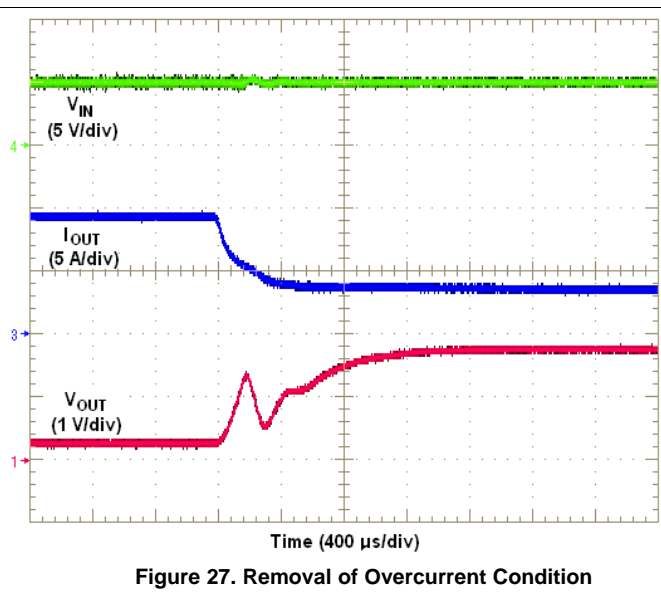
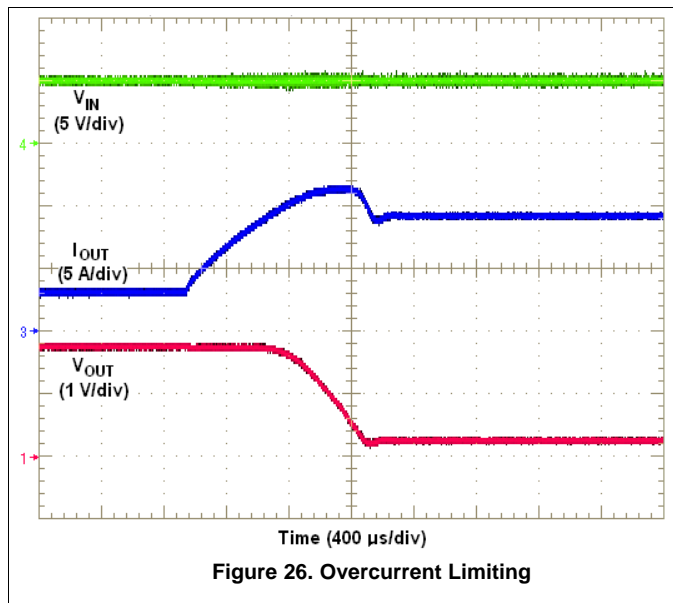

8.12 Synchronization (CLK)

An internal phase locked loop (PLL) has been implemented to allow synchronization between 500 kHz and 2 MHz, and to easily switch from RT mode to CLK mode. To implement the synchronization feature, connect a square wave clock signal to the RT/CLK pin with a minimum pulse width of 75 ns. The maximum clock pulse width must be calculated using Equation 2. The clock signal amplitude must transition lower than 0.4 V and higher than 2.2 V. The start of the switching cycle is synchronized to the falling edge of RT/CLK pin. Applications requiring both RT mode and CLK mode, configure the device as shown in Figure 28.

Before the external clock is present, the device works in RT mode and the switching frequency is set by the RT resistor (R_{RT}). When the external clock is present, the CLK mode overrides the RT mode. The device switches from RT mode to CLK mode and the RT/CLK pin becomes high impedance as the PLL starts to lock onto the frequency of the external clock. The device will lock to the external clock frequency approximately 15 μ s after a valid clock signal is present. It is not recommended to switch from CLK mode back to RT mode because the internal switching frequency drops to a lower frequency before returning to the switching frequency set by the RT resistor.

$$CLK_PW_{MAX} = \frac{0.75 \times \left(1 - \frac{V_{OUT}}{V_{IN(min)}} \right)}{f_{SW}} \quad (2)$$

Figure 28. CLK/RT Configuration

Select the synchronization frequency based on the output voltages of the devices being synchronized. Table 9 shows the allowable V_{OUT} range for a given switching frequency when operating from a typical 5 V bus and a typical 3.3 V bus. For the most optimal solution, synchronize to a frequency in the center of the allowable frequency range. For example, an application requires synchronizing three LMZ30606 devices with output voltages of 1.2V, 1.8V, and 3.3V, all powered from $V_{IN} = 5V$. Table 9 shows that all three output voltages can be synchronized to any frequency between 600 kHz to 1 MHz. For the most optimal solution, choose 800 kHz as the synchronization frequency. (Values included in the table are based on a resistive load.)

Table 9. Synchronization Frequency vs Output Voltage

SYNCHRONIZATION FREQUENCY (kHz)	R_{RT} (k Ω)	$V_{IN} = 5V$ (+/- 10%)		$V_{IN} = 3.3V$ (+/- 5%)	
		V_{OUT} RANGE (V)		V_{OUT} RANGE (V)	
		MIN	MAX	MIN	MAX
500	open	0.8	1.8	0.8	2.5
550	3400	0.8	2.2	0.8	2.5
600	1800	0.8	3.3	0.8	2.5
650	1200	0.8	3.6	0.8	2.5
700	887	0.8	3.6	0.8	2.5
750	715	0.9	3.6	0.8	2.5
800	590	0.9	3.6	0.8	2.5
850	511	1.0	3.6	0.8	2.5
900	442	1.0	3.6	0.8	2.5
950	392	1.1	3.6	0.8	2.5
1000	348	1.1	3.6	0.8	2.5
1250	232	1.4	3.6	0.9	2.4
1500	174	1.7	3.5	1.1	2.3
1750	137	2.0	3.4	1.3	2.3

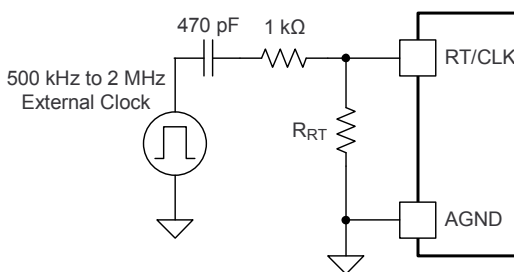
Table 9. Synchronization Frequency vs Output Voltage (continued)

SYNCHRONIZATION FREQUENCY (kHz)	R _{RT} (kΩ)	VIN = 5V (+/- 10%)		VIN = 3.3V (+/- 5%)	
		V _{OUT} RANGE (V)		V _{OUT} RANGE (V)	
		MIN	MAX	MIN	MAX
2000	113	2.2	3.3	1.4	2.2

8.13 Sequencing (SS/TR)

Many of the common power supply sequencing methods can be implemented using the SS/TR, INH and PWRGD pins. The sequential method is illustrated in Figure 29 using two LMZ30606 devices. The PWRGD pin of the first device is coupled to the INH pin of the second device which enables the second power supply once the primary supply reaches regulation. Figure 30 shows sequential turn-on waveforms of two LMZ30606 devices.

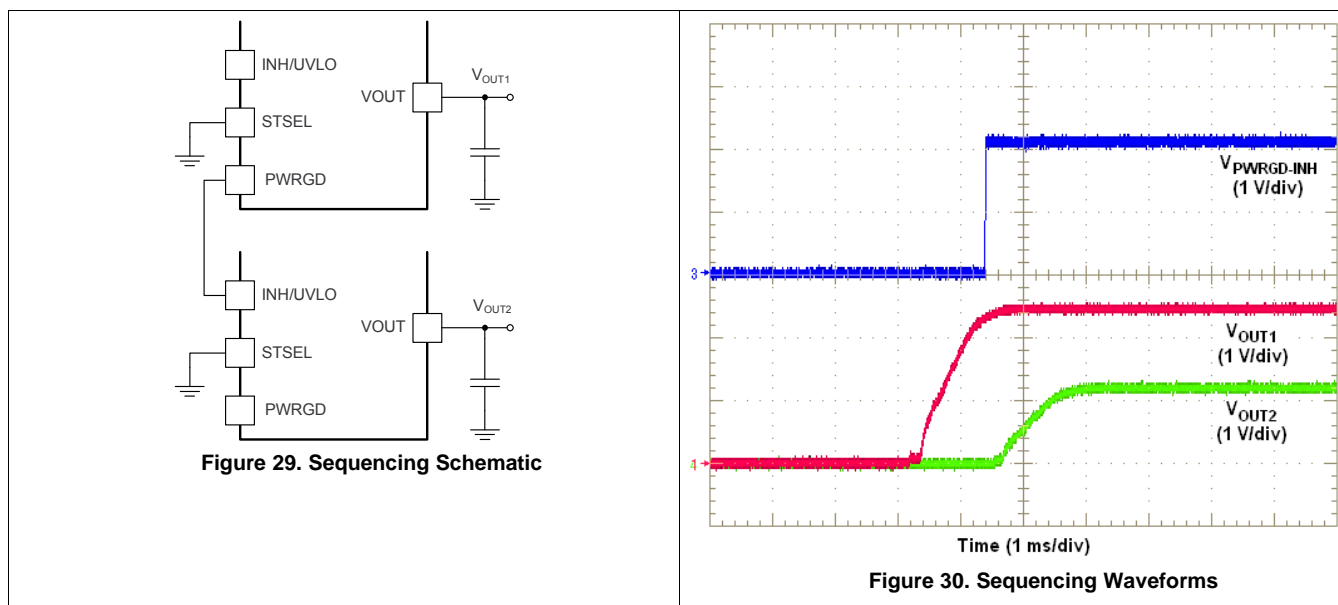

Simultaneous power supply sequencing can be implemented by connecting the resistor network of R1 and R2 shown in Figure 31 to the output of the power supply that needs to be tracked or to another voltage reference source. Figure 32 shows simultaneous turn-on waveforms of two LMZ30606 devices. Use Equation 3 and Equation 4 to calculate the values of R1 and R2.

$$R1 = \frac{(V_{OUT2} \times 12.6)}{0.799} \text{ (k}\Omega\text{)}$$

(3)

$$R2 = \frac{0.799 \times R1}{(V_{OUT2} - 0.799)} \text{ (k}\Omega\text{)}$$

(4)

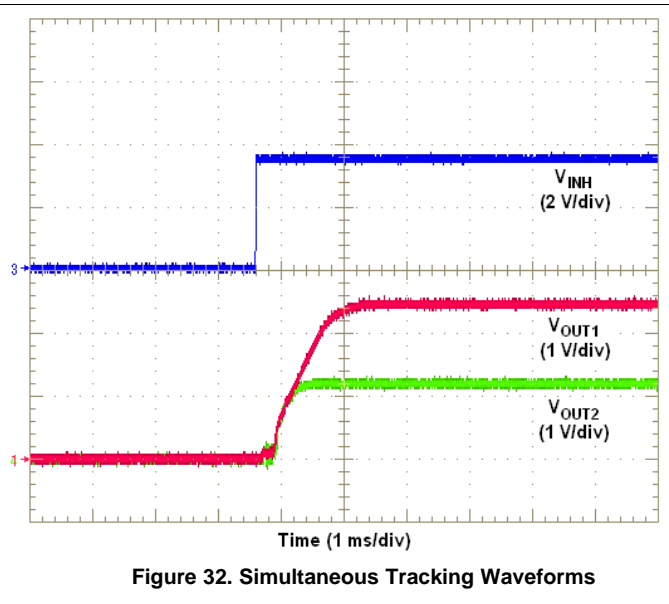
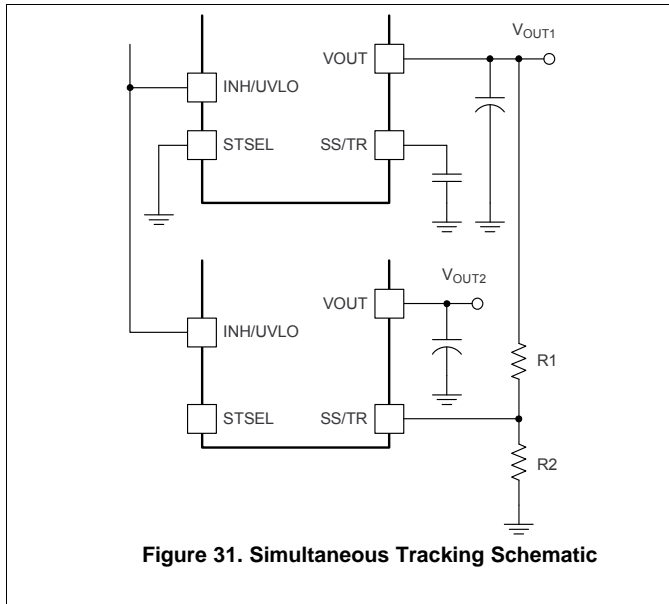

8.14 Programmable Undervoltage Lockout (UVLO)

The LMZ30606 implements internal UVLO circuitry on the VIN pin. The device is disabled when the VIN pin voltage falls below the internal VIN UVLO threshold. The internal VIN UVLO rising threshold is 3.135 V(max) with a typical hysteresis of 300 mV.

If an application requires a higher UVLO threshold on the VIN pin, the UVLO pin can be configured as shown in [Figure 33](#). [Table 10](#) lists standard values for R_{UVLO} to adjust the VIN UVLO voltage up.

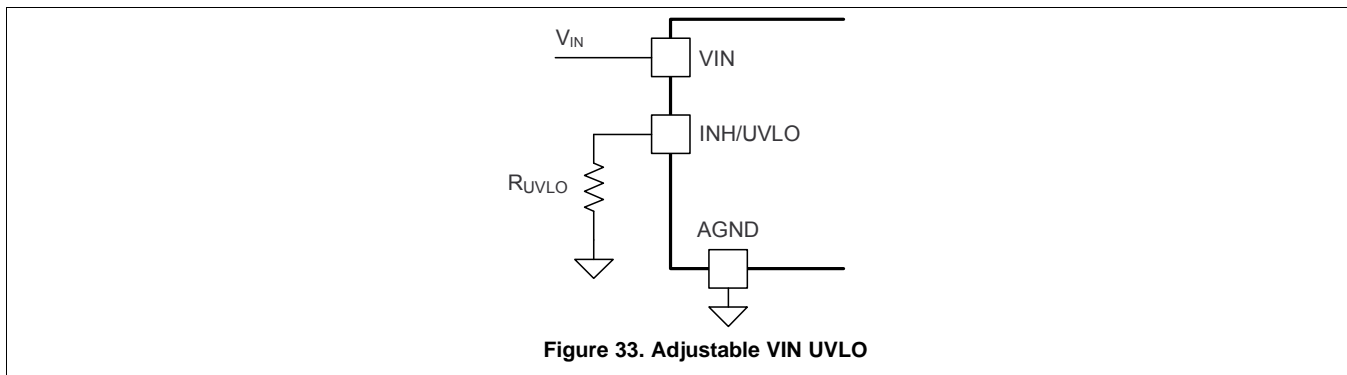

Table 10. Standard Resistor values for Adjusting VIN UVLO

VIN UVLO (V) (typ)	3.25	3.5	3.75	4.0	4.25	4.5	4.75
R_{UVLO} (k Ω)	294	133	86.6	63.4	49.9	42.2	35.7
Hysteresis (mV)	325	335	345	355	365	375	385

8.15 Thermal Shutdown

The internal thermal shutdown circuitry forces the device to stop switching if the junction temperature exceeds 170°C typically. The device reinitiates the power up sequence when the junction temperature drops below 150°C typically.

8.16 EMI

The LMZ30606 is compliant with EN55022 Class B radiated emissions. [Figure 34](#) and [Figure 35](#) show typical examples of radiated emissions plots for the LMZ30606 operating from 5V and 3.3V respectively. Both graphs include the plots of the antenna in the horizontal and vertical positions.

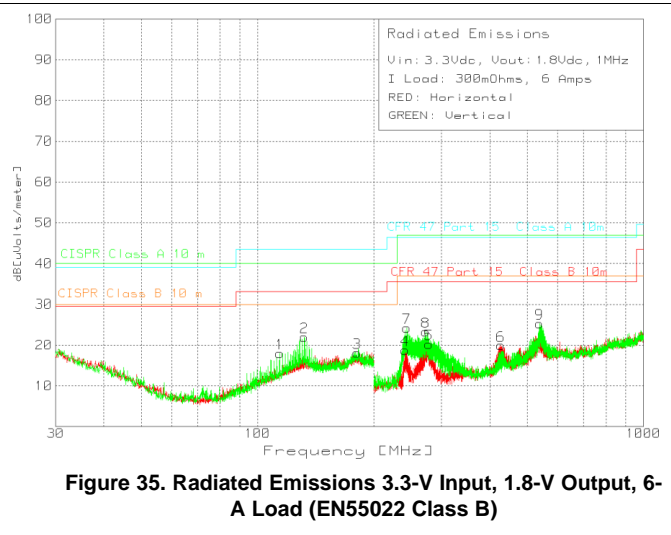
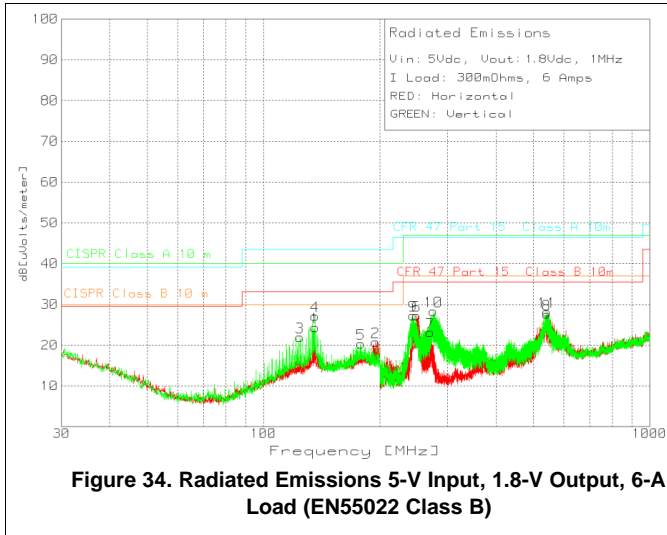

8.17 Layout Considerations

To achieve optimal electrical and thermal performance, an optimized PCB layout is required. Figure 36, shows a typical PCB layout. Some considerations for an optimized layout are:

- Use large copper areas for power planes (VIN, VOUT, and PGND) to minimize conduction loss and thermal stress.
- Place ceramic input and output capacitors close to the module pins to minimize high frequency noise.
- Locate additional output capacitors between the ceramic capacitor and the load.
- Place a dedicated AGND copper area beneath the LMZ30606.
- Connect the AGND and PGND copper area at one point; directly at the pin 37 PowerPad using multiple vias.
- Place R_{SET} , R_{RT} , and C_{SS} as close as possible to their respective pins.
- Use multiple vias to connect the power planes to internal layers.

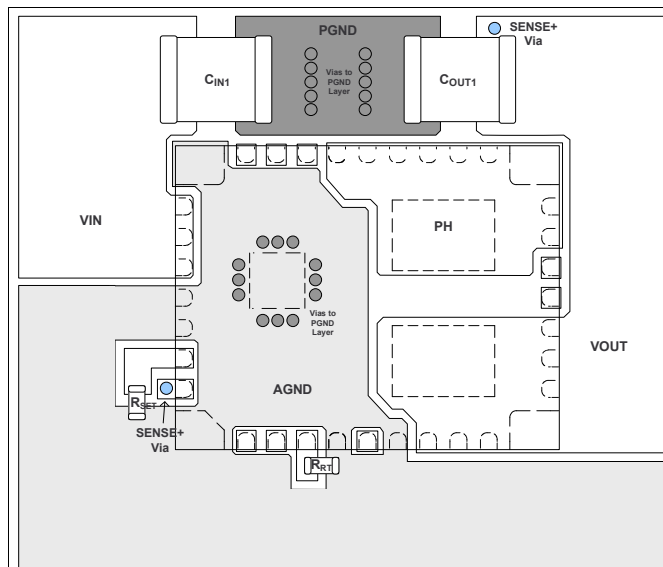

Figure 36. Typical Top-Layer Recommended Layout

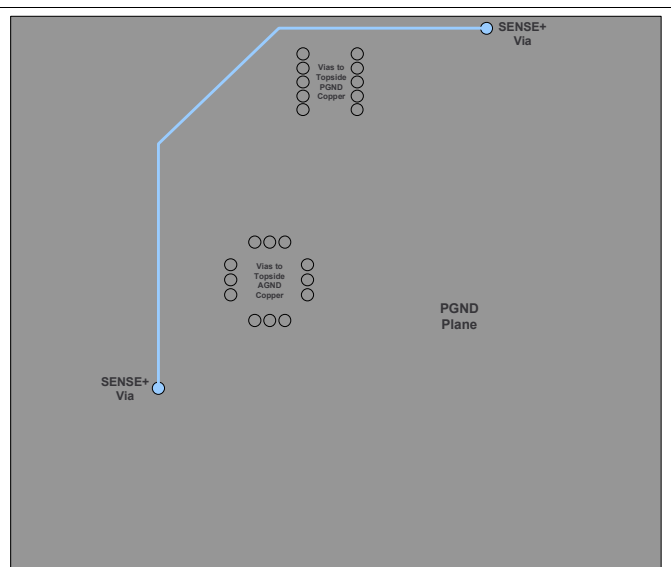

Figure 37. Typical PGND-Layer Recommended Layout

9 Revision History

NOTE: Page numbers for previous revisions may differ from page numbers in the current version.

Changes from Revision A (June 2017) to Revision B

Page

-
- Added WEBENCH® design links for the LMZ30606..... 1
 - Increased the peak reflow temperature and maximum number of reflows to JEDEC specifications for improved manufacturability 2
 - Added *Device and Documentation Support* section 26
 - Added *Mechanical, Packaging, and Orderable Information* section..... 27
-

Changes from Original (July 2013) to Revision A

Page

-
- Added peak reflow and maximum number of reflows information 2
-

10 Device and Documentation Support

10.1 Device Support

10.1.1 Development Support

10.1.1.1 Custom Design With WEBENCH® Tools

Click [here](#) to create a custom design using the LMZ30606 device with the WEBENCH® Power Designer.

1. Start by entering the input voltage (V_{IN}), output voltage (V_{OUT}), and output current (I_{OUT}) requirements.
2. Optimize the design for key parameters such as efficiency, footprint, and cost using the optimizer dial.
3. Compare the generated design with other possible solutions from Texas Instruments.

The WEBENCH Power Designer provides a customized schematic along with a list of materials with real-time pricing and component availability.

In most cases, these actions are available:

- Run electrical simulations to see important waveforms and circuit performance
- Run thermal simulations to understand board thermal performance
- Export customized schematic and layout into popular CAD formats
- Print PDF reports for the design, and share the design with colleagues

Get more information about WEBENCH tools at www.ti.com/WEBENCH.

10.2 Receiving Notification of Documentation Updates

To receive notification of documentation updates, navigate to the device product folder on ti.com. In the upper right corner, click on *Alert me* to register and receive a weekly digest of any product information that has changed. For change details, review the revision history included in any revised document.

10.3 Community Resources

The following links connect to TI community resources. Linked contents are provided "AS IS" by the respective contributors. They do not constitute TI specifications and do not necessarily reflect TI's views; see TI's [Terms of Use](#).

TI E2E™ Online Community *TI's Engineer-to-Engineer (E2E) Community*. Created to foster collaboration among engineers. At e2e.ti.com, you can ask questions, share knowledge, explore ideas and help solve problems with fellow engineers.

Design Support *TI's Design Support* Quickly find helpful E2E forums along with design support tools and contact information for technical support.

10.4 Trademarks

E2E is a trademark of Texas Instruments.

WEBENCH is a registered trademark of Texas Instruments.

All other trademarks are the property of their respective owners.

10.5 Electrostatic Discharge Caution



This integrated circuit can be damaged by ESD. Texas Instruments recommends that all integrated circuits be handled with appropriate precautions. Failure to observe proper handling and installation procedures can cause damage.

ESD damage can range from subtle performance degradation to complete device failure. Precision integrated circuits may be more susceptible to damage because very small parametric changes could cause the device not to meet its published specifications.

10.6 Glossary

[SLYZ022](#) — *TI Glossary*.

This glossary lists and explains terms, acronyms, and definitions.

11 Mechanical, Packaging, and Orderable Information

The following pages include mechanical, packaging, and orderable information. This information is the most current data available for the designated devices. This data is subject to change without notice and revision of this document. For browser-based versions of this data sheet, refer to the left-hand navigation.

11.1 Tape and Reel Information

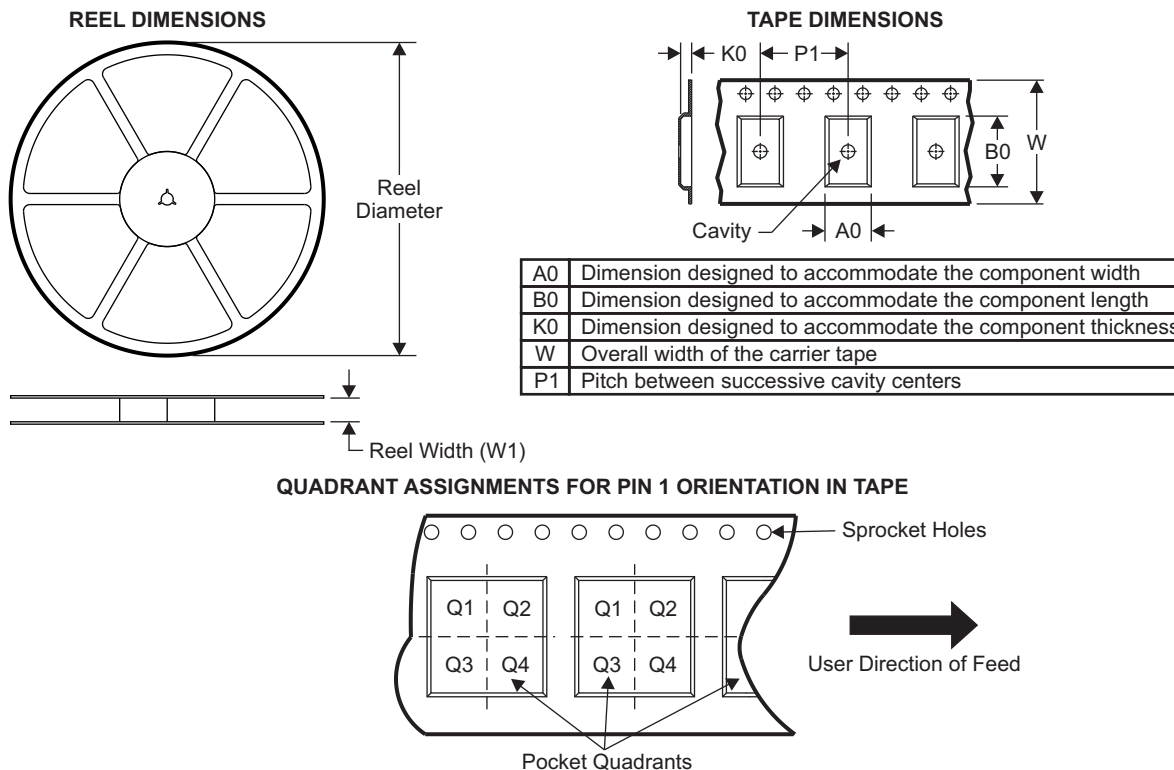

Device	Package Type	Package Drawing	Pins	SPQ	Reel Diameter (mm)	Reel Width W1 (mm)	A0 (mm)	B0 (mm)	K0 (mm)	P1 (mm)	W (mm)	Pin1 Quadrant
LMZ30606RKGR	B1QFN	RKG	39	500	330.0	24.4	9.35	11.35	3.1	16.0	24.0	Q1
LMZ30606RKGT	B1QFN	RKG	39	250	330.0	24.4	9.35	11.35	3.1	16.0	24.0	Q1

LMZ30606

SNVS995B –JULY 2013–REVISED APRIL 2018

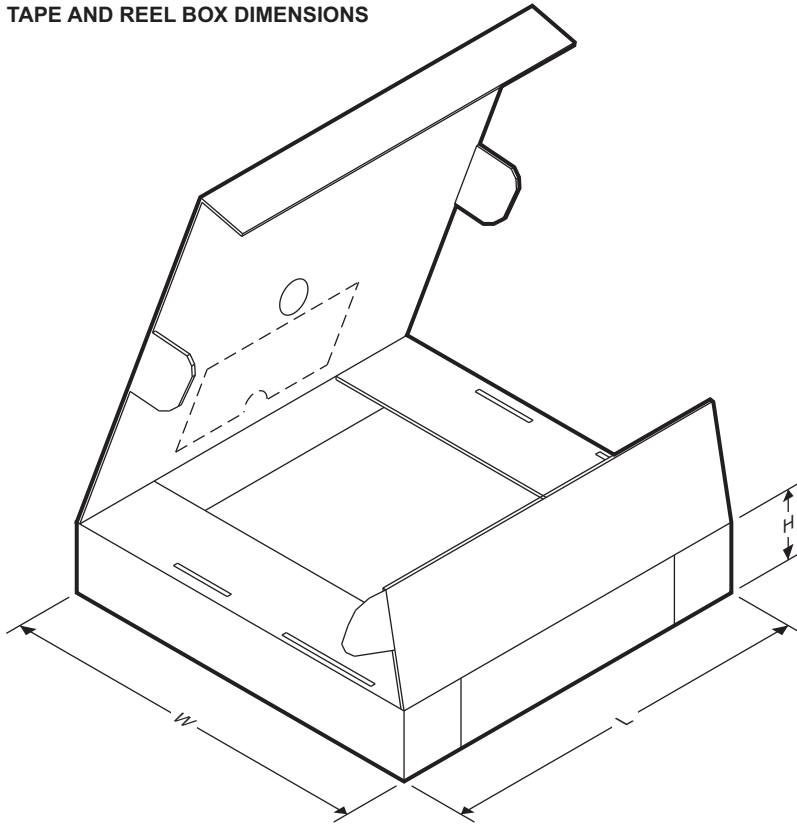
www.ti.com
TAPE AND REEL BOX DIMENSIONS

Device	Package Type	Package Drawing	Pins	SPQ	Length (mm)	Width (mm)	Height (mm)
LMZ30606RKGR	B1QFN	RKG	39	500	383.0	353.0	58.0
LMZ30606RKGT	B1QFN	RKG	39	250	383.0	353.0	58.0

PACKAGING INFORMATION

Orderable Device	Status (1)	Package Type	Package Drawing	Pins	Package Qty	Eco Plan (2)	Lead/Ball Finish (6)	MSL Peak Temp (3)	Op Temp (°C)	Device Marking (4/5)	Samples
LMZ30606RKGR	ACTIVE	B1QFN	RKG	39	500	RoHS (In Work) & Green (In Work)	CU NIPDAU	Level-3-250C-168 HR	-40 to 85	(54618, LMZ30606)	Samples
LMZ30606RKGT	ACTIVE	B1QFN	RKG	39	250	RoHS (In Work) & Green (In Work)	CU NIPDAU	Level-3-250C-168 HR	-40 to 85	(54618, LMZ30606)	Samples

(1) The marketing status values are defined as follows:

ACTIVE: Product device recommended for new designs.

LIFEBUY: TI has announced that the device will be discontinued, and a lifetime-buy period is in effect.

NRND: Not recommended for new designs. Device is in production to support existing customers, but TI does not recommend using this part in a new design.

PREVIEW: Device has been announced but is not in production. Samples may or may not be available.

OBSOLETE: TI has discontinued the production of the device.

(2) **RoHS:** TI defines "RoHS" to mean semiconductor products that are compliant with the current EU RoHS requirements for all 10 RoHS substances, including the requirement that RoHS substance do not exceed 0.1% by weight in homogeneous materials. Where designed to be soldered at high temperatures, "RoHS" products are suitable for use in specified lead-free processes. TI may reference these types of products as "Pb-Free".

RoHS Exempt: TI defines "RoHS Exempt" to mean products that contain lead but are compliant with EU RoHS pursuant to a specific EU RoHS exemption.

Green: TI defines "Green" to mean the content of Chlorine (Cl) and Bromine (Br) based flame retardants meet JS709B low halogen requirements of <=1000ppm threshold. Antimony trioxide based flame retardants must also meet the <=1000ppm threshold requirement.

(3) MSL, Peak Temp. - The Moisture Sensitivity Level rating according to the JEDEC industry standard classifications, and peak solder temperature.

(4) There may be additional marking, which relates to the logo, the lot trace code information, or the environmental category on the device.

(5) Multiple Device Markings will be inside parentheses. Only one Device Marking contained in parentheses and separated by a "~" will appear on a device. If a line is indented then it is a continuation of the previous line and the two combined represent the entire Device Marking for that device.

(6) Lead/Ball Finish - Orderable Devices may have multiple material finish options. Finish options are separated by a vertical ruled line. Lead/Ball Finish values may wrap to two lines if the finish value exceeds the maximum column width.

Important Information and Disclaimer:The information provided on this page represents TI's knowledge and belief as of the date that it is provided. TI bases its knowledge and belief on information provided by third parties, and makes no representation or warranty as to the accuracy of such information. Efforts are underway to better integrate information from third parties. TI has taken and continues to take reasonable steps to provide representative and accurate information but may not have conducted destructive testing or chemical analysis on incoming materials and chemicals. TI and TI suppliers consider certain information to be proprietary, and thus CAS numbers and other limited information may not be available for release.

In no event shall TI's liability arising out of such information exceed the total purchase price of the TI part(s) at issue in this document sold by TI to Customer on an annual basis.



MECHANICAL DATA

RKG (R-PB1QFN-N39)

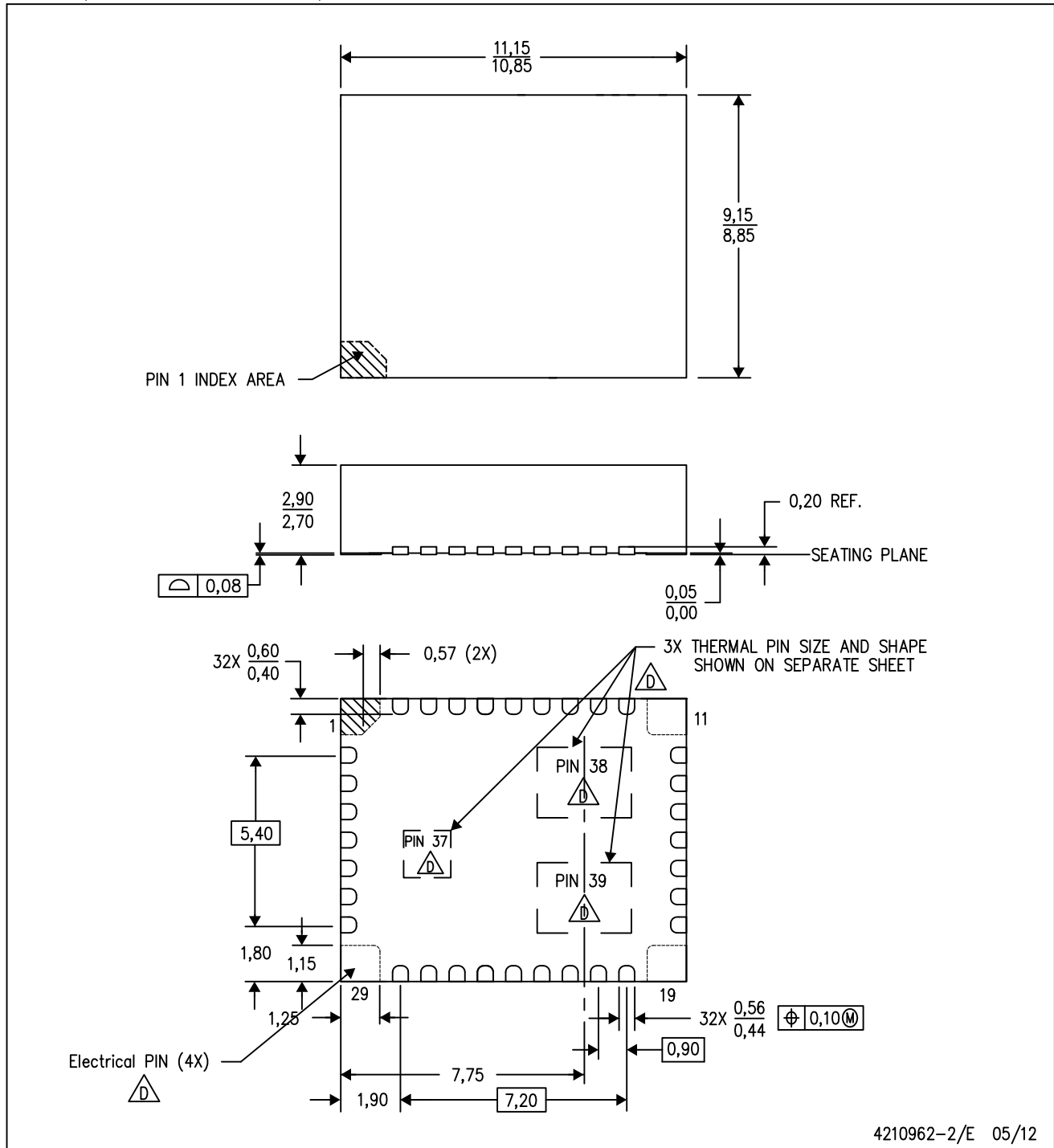
PLASTIC QUAD FLATPACK NO-LEAD



4210962-2/E 05/12

- NOTES:
- A. All linear dimensions are in millimeters. Dimensioning and tolerancing per ASME Y14.5M-1994.
 - B. This drawing is subject to change without notice.
 - C. Quad Flatpack, No-leads (QFN) package configuration.
 -  D. The package thermal pad must be soldered to the board for thermal and mechanical performance.
 - E. See the additional figure in the Product Data Sheet for details regarding the exposed thermal pad features and dimensions.
 -  F. The package thermal performance may be enhanced by bonding the thermal pad to an external thermal plane.

IMPORTANT NOTICE AND DISCLAIMER

TI PROVIDES TECHNICAL AND RELIABILITY DATA (INCLUDING DATASHEETS), DESIGN RESOURCES (INCLUDING REFERENCE DESIGNS), APPLICATION OR OTHER DESIGN ADVICE, WEB TOOLS, SAFETY INFORMATION, AND OTHER RESOURCES "AS IS" AND WITH ALL FAULTS, AND DISCLAIMS ALL WARRANTIES, EXPRESS AND IMPLIED, INCLUDING WITHOUT LIMITATION ANY IMPLIED WARRANTIES OF MERCHANTABILITY, FITNESS FOR A PARTICULAR PURPOSE OR NON-INFRINGEMENT OF THIRD PARTY INTELLECTUAL PROPERTY RIGHTS.

These resources are intended for skilled developers designing with TI products. You are solely responsible for (1) selecting the appropriate TI products for your application, (2) designing, validating and testing your application, and (3) ensuring your application meets applicable standards, and any other safety, security, or other requirements. These resources are subject to change without notice. TI grants you permission to use these resources only for development of an application that uses the TI products described in the resource. Other reproduction and display of these resources is prohibited. No license is granted to any other TI intellectual property right or to any third party intellectual property right. TI disclaims responsibility for, and you will fully indemnify TI and its representatives against, any claims, damages, costs, losses, and liabilities arising out of your use of these resources.

TI's products are provided subject to TI's Terms of Sale (www.ti.com/legal/termsofsale.html) or other applicable terms available either on ti.com or provided in conjunction with such TI products. TI's provision of these resources does not expand or otherwise alter TI's applicable warranties or warranty disclaimers for TI products.

Mailing Address: Texas Instruments, Post Office Box 655303, Dallas, Texas 75265
Copyright © 2019, Texas Instruments Incorporated

Looking for pricing, stock, or lifecycle information?

Click below to explore more details on WIN SOURCE:

 [View LMZ30606EVM-003 on WIN SOURCE](#)

 [Texas Instruments](#) Information

Optimize Your Supply Chain with WIN SOURCE Solutions

-  Global Sourcing Solution
-  Obsolete Management
-  Cost Control Management
-  Shortage Management
-  Alternative Solution
-  Excess Inventory Management