

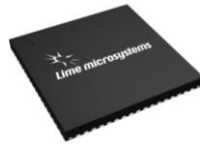

THE DATASHEET OF LMS6002DFN





LMS6002D

Multi-band Multi-standard Transceiver with Integrated Dual DACs and ADCs

SUMMARY FEATURES

- Single chip transceiver covering 0.3-3.8GHz frequency range
- Digital interface to baseband with integrated 12 bit D/A and A/D converters
- Fully differential baseband signals
- Few external components
- Programmable modulation bandwidth: 1.5, 1.75, 2.5, 2.75, 3, 3.84, 5, 5.5, 6, 7, 8.75, 10, 12, 14, 20 and 28MHz
- Supports both TDD and FDD operation modes
- Low voltage operation, 1.8V and 3.3V

- 120 pin DQFN package
- Power down option
- Serial port interface

APPLICATIONS

- Femtocell and Picocell base stations
- Repeaters
- Broadband wireless communication devices for WCDMA/HSPA, LTE, GSM, CDMA2000, IEEE® 802.16x radios

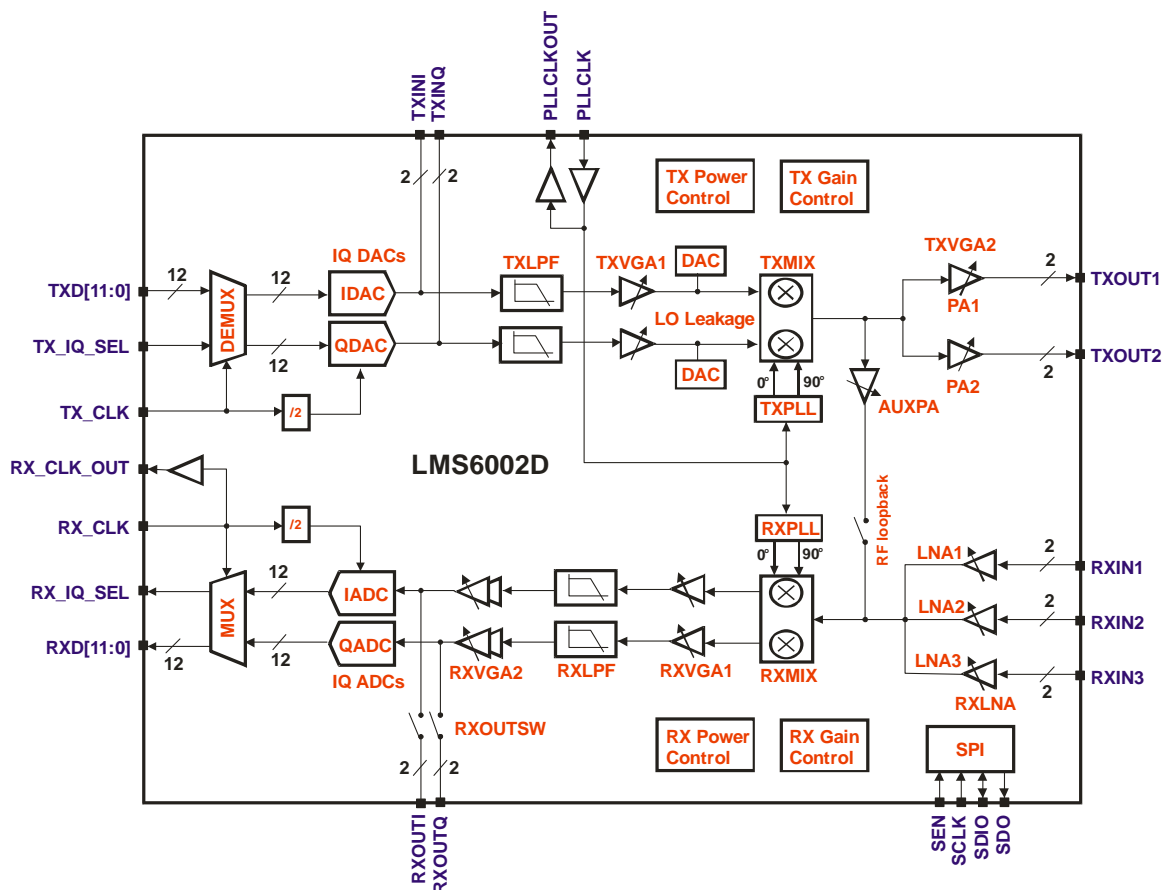

Figure 1: Functional block diagram

GENERAL DESCRIPTION

The LMS6002D is a fully integrated, multi-band, multi-standard RF transceiver for 3GPP (WCDMA/HSPA, LTE), 3GPP2 (CDMA2000) and 4G LTE applications, as well as for GSM pico BTS. It combines the

LNA, PA driver, RX/TX mixers, RX/TX filters, synthesizers, RX gain control, and TX power control with very few external components.

The information contained in this document is subject to change without prior notice. Lime Microsystems assumes no responsibility for its use, nor for infringement of patents or other rights of third parties. Lime Microsystems' standard terms and conditions apply at all times.

LMS6002D - Multi-band Multi-standard Transceiver with Integrated Dual DACs and ADCs

The top level architecture of LMS6002D transceiver is shown in Figure 1. Both transmitter and receiver are implemented as zero IF architectures providing up to 28MHz modulation bandwidth (equivalent to 14MHz baseband IQ bandwidth).

On the transmit side, IQ DAC samples from the baseband processor are provided to the LMS6002D on a 12 bit multiplexed parallel CMOS input level bus. Analog IQ signals are generated by on chip transmit DACs. These are fed to the TXINI and TXINQ inputs. Transmit low pass filters (TXLPF) remove the images generated by zero hold effect of the DACs. The IQ signals are then amplified (TXVGA1) and DC offset is inserted in the IQ path by LO leakage DACs in order to cancel the LO leakage. The IQ signals are then mixed with the transmit PLL (TXPLL) output to produce a modulated RF signal. This RF signal is then split and amplified by two separate variable gain amplifiers (TXVGA2) and two off chip outputs are provided as RF output.

Transmitter gain control range of 56dB is provided by IF (TXVGA1, 31dB range) and RF (TXVGA2, 25 dB range) variable gain amplifiers. Both TXVGAs have 1dB gain step control.

The LMS6002D provides an RF loop back option (see Figure 1) which enables the TX RF signal to be fed back into the baseband for calibration and test purposes. The RF loop back signal is amplified by an auxiliary PA (AUXPA) in order to increase the dynamic range of the loop.

On the receive side, three separate inputs are provided each with a dedicated LNA. Each port preconditioned RF signal is first amplified by a programmable low noise amplifier (RXLNA). The RF signal is then

mixed with the receive PLL (RXPLL) output to directly down convert to baseband. Large AGC steps can be implemented by an IF amplifier (RXVGA1) prior to the programmable bandwidth lowpass channel select filters (RXLPF). The received IQ signal is further amplified by a programmable gain amplifier RXVGA2. DC offset is applied at the input of RXVGA2 to prevent saturation and to preserve receive the ADC(s) dynamic range. The resulting analog receive IQ signals are converted into the digital domain using the on chip receive ADCs and provided as an output to the baseband processor on a multiplexed 12 bit CMOS output level parallel bus. The receive clock, RX_CLK, is provided off chip at the RX_CLK_OUT pin and can be used to synchronise with the baseband digital receive data sampling clock.

By closing the RXOUT switch and powering down RXVGA2, the RXOUTI and RXOUTQ pins can be used as IQ ADCs inputs. In this configuration the ADCs can be used to measure two external signals, such as an off chip PA temperature sensor or peak detector.

Two transmitter outputs (TXOUT1, TXOUT2) and three receiver inputs (RXIN1, RXIN2, RXIN3) are provided to facilitate multi-band operation.

The functionality of the LMS6002D is fully controlled by a set of internal registers which can be accessed through a serial port.

In order to enable full duplex operation, the LMS6002D contains two separate synthesizers (TXPLL, RXPLL) both driven from the same reference clock source PLLCLK. The PLLCLK signal is provided at the PLLCLKOUT output pin and can be used as the baseband clock.

Differential signalling is done in the receive and transmit analog paths throughout the chip.

Parameter	Condition/Comment	Min	Typ	Max	Unit
TRX RF Frequency Range		0.3		3.8	GHz
Baseband Bandwidth		0.75		14	MHz
Frequency Resolution	Using 41MHz PLL reference clock			2.4	Hz
TRX 3.3V Supply		3.1	3.3	3.5	V
TRX 1.8V Supply		1.7	1.8	1.9	V
TX Supply Current	At maximum gain		280		mA
RX Supply Current	At maximum gain		220		mA
Digital Core Supply Voltage		1.7	1.8	1.9	V
Digital Peripheral (IO) Supply Voltage	Can go below 3.3V nominal to support LV CMOS signalling	1.7	3.3	3.5	V
Ambient Temperature		-40	25	85	°C
Storage Temperature		-65		125	°C
Maximum RF Output Power	Continuous wave		6		dBm
Absolute Maximum RF Input Power	No damage	23			dBm
PLL Reference Clock	For continuous LO frequency range	23		41	MHz
PLL Phase Noise	1MHz offset		-125		dBc/Hz

Table 1: General specifications

Parameter	Condition/Comment	Min	Typ	Max	Unit
TRX RF Bandwidth		0.3		3.8	GHz
Transmit Input Impedance	Differential, programmable		100		Ohms
Transmit Load Impedance	Differential		65		Ohms
Transmit Differential I and Q Input Voltages	Differential Common mode		250 65		mVpp mV
Transmit Gain Control Range	TXVGA1, TXVGA2		56		dB
Transmit Gain Control Step			1		dB
TX LO Leakage	LO leakage not calibrated		-50		dBc
RX LNA1 Frequency Range	Narrow band	0.3		2.8	GHz
RX LNA2 Frequency Range	Narrow band	1.5		3.8	GHz
RX LNA3 Frequency Range	Broad band	0.3		3.0	GHz
RX LNA1 Input Impedance	Differential		50		Ohms
RX LNA2 Input Impedance	Differential		50		Ohms
RX LNA3 Input Impedance	Differential		200		Ohms
Receive Load Impedance	Differential		2k		Ohms
Receive Load Capacitance			5		pF
Noise Figure	LNA1 at 0.95GHz LNA2 at 1.95GHz LNA3 at 1.95GHz		3.5 5.5 10		dB
3 rd Order Input Referred Intercept Point	LNA2 at Mid. Gain		-1		dBm
Receive Gain Control Range	RXLNA, RXVGA1, RXVGA2		61		dB
Receive Gain Control Step	RXVGA1, not log-linear RXVGA2		3	1	dB

Table 2: General RF specifications

TX GAIN CONTROL

The LMS6002D transmitter has two programmable gain stages, TXVGA1 is located in the IF section and TXVGA2 is in the RF section, (see Figure 2). TXVGA1 is implemented on the I and Q branches but controlled by a single control word. TXVGA2 consists of 2 amplifiers one for each of the transmitter outputs, however only one of these output amplifiers can be active at any time.

Note: The TXLPF has a gain of 6dB or 0dB when bypassed.

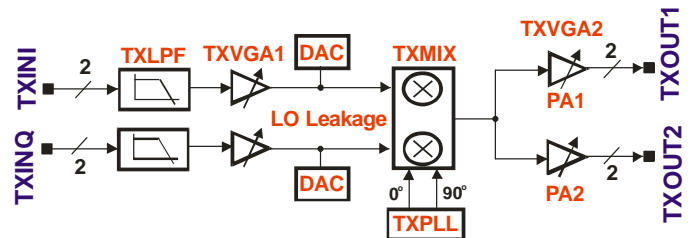

Figure 2: TX gain control architecture

Parameter	Condition	Min	Typ	Max	Unit
TXLPF Gain	0 dB gain when bypassed	0		6	dB
TXVGA1 Gain Control Range			31		dB
TXVGA1 Gain Step Size	Guaranteed monotonic		1		dB
TXVGA2 Gain Control Range			25		dB
TXVGA2 Gain Step Size	Guaranteed monotonic		1		dB

Table 3: TX gain control

RX GAIN CONTROL

The LMS6002D receiver has three gain control elements, RXLNA, RXVGA1, and RXVGA2 (see Figure 3). RXLNA gain control consists of a single 6dB step for AGC when large in co-channel blockers are present and a reduction in system NF is acceptable. The main LNAs (LNA1 and LNA2) have fine gain control via a 6 bit word which offers $\pm 6\text{dB}$ control intended for frequency correction when large input bandwidths are required.

RXVGA1 offers 25dB of control range, a 7 bit control word is used and the response is not log-linear. Maximum step size is 1dB. RXVGA1 is intended for AGC steps needed to reduce system gain prior to the channel filters when large in band blockers are present. This gain can be under control of the baseband or fixed on calibration.

RXVGA2 provides the bulk of gain control for AGC if a constant RX signal level at the ADC input is required. It has 30dB gain range control in 3dB steps.

Note: RXLPF has a gain of 0dB when bypassed.

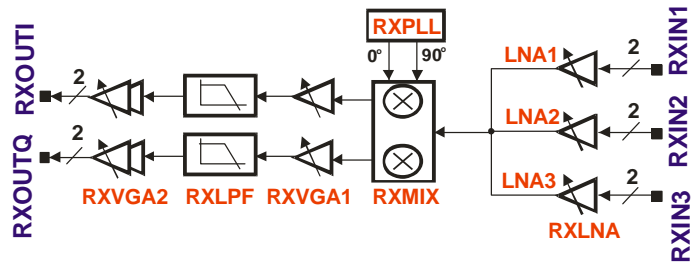

Figure 3: RX gain control architecture

Parameter	Condition	Min	Typ	Max	Unit
RXLNA Gain Control Range	Single step	0		6	dB
RXVGA1 Gain Control Range			25		dB
RXVGA1 Gain Step Size	Not log-linear			1	dB
RXLPF Gain	0 dB gain when bypassed	0		6	dB
RXVGA2 Gain Control Range			30		dB
RXVGA2 Gain Step Size	Guaranteed monotonic		3		dB

Table 4: RX gain control

SYNTHESIZERS

LMS6002D has two low phase noise synthesizers to enable full duplex operation. Both synthesizers are capable of output frequencies up to 3.8GHz. Each synthesizer uses a fractional-N PLL architecture as shown in Figure 4. The same reference frequency is used for both synthesizers and is flexible between 23 to 41MHz. The synthesizers produce a complex output with suitable level to drive IQ mixers in both the TX and the RX paths.

The LMS6002D can accept clipped sine as well as the CMOS level signals as the PLL reference clock. Both DC and AC coupling are supported as shown in Figure 5. Internal buffer self biasing must be enabled for AC coupling mode. PLL reference clock input can also be low voltage CMOS (2.5V or 1.8V, for example) which is implemented by lowering clock buffer supply PVDDSPI33.

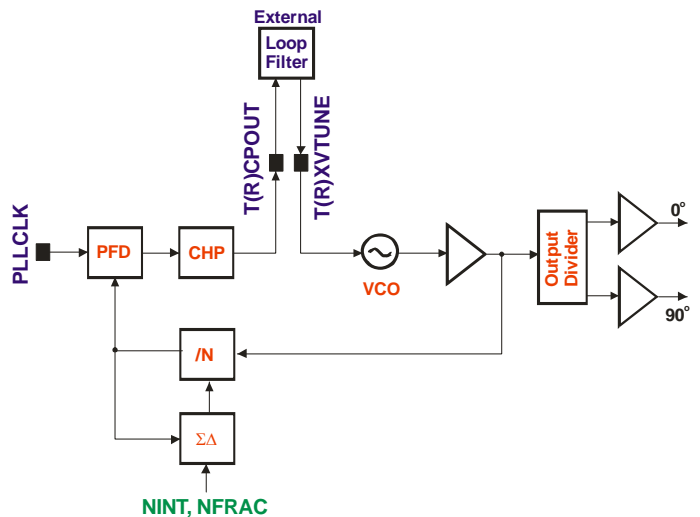

Figure 4: PLL architecture

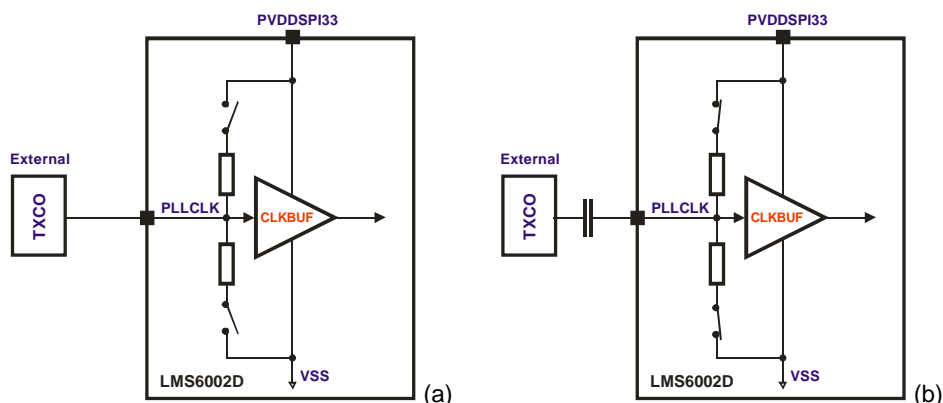

Figure 5: PLL reference clock input buffer, (a) DC coupled (b) AC coupled

Parameter	Condition	Min	Typ	Max	Unit
Frequency Range		0.3		3.8	GHz
Reference Amplitude	At PVDDSPI33=3.3V	0.2	0.8	3.3	V _{pp}
Reference Frequency	For continuous LO frequency range	23		41	MHz
Frequency Step Size	At 41MHz reference clock			2.4	Hz
Phase Noise	800MHz				
10 KHz offset			-94		
100 KHz offset			-113		
1 MHz offset			-130		
Phase Noise	1.9GHz				
10 KHz offset			-89		
100 KHz offset			-95		
1 MHz offset			-125		
Phase Noise	2.6GHz				
10 KHz offset			-86		
100 KHz offset			-90		
1 MHz offset			-125		
Reference Spurious Outputs				-50	dBc
Other Spurious Outputs				-50	dBc
IQ Phase Error	800MHz		1		deg
	1.9GHz		3		
	2.6GHz		9		
IQ Amplitude Error			0.4		dB
PLL settling time	To 1ppm, 50kHz loop bandwidth		20		μs

Table 5: Synthesizer specifications

RF PORTS

LMS6002D has two transmitter outputs and three receiver inputs.

The transmitter output ports are optimized for a 65Ω differential load, the final stage amplifiers are open drain and require +3.3V voltage supply, see LMS6002D typical application circuit in Figure 19.

The receiver inputs are all different. RXIN1 is the low frequency input and can operate in the range 0.3 – 2.8GHz, RXIN2 is the high frequency input and can operate in the range 1.5 – 3.8GHz. Both RXIN1 and RXIN2 require matching circuits for optimum performance. A simple match is shown in Figure 19. RXIN3 is a broadband input covering the range 0.3 – 3.0GHz, it is 200Ω differential and is typically matched with a wideband transformer.

TX and RX LOW PASS FILTERS

LMS6002D integrates highly selective low pass filters in both TX and RX paths. Filters have a programmable pass band in order to provide more flexibility on the DAC/ADC clock frequency and also to provide excellent adjacent channel rejection in the receive chain. The following LPF pass bands are supported: 14, 10, 7, 6, 5, 4.375, 3.5, 3, 2.75, 2.5, 1.92, 1.5, 1.375, 1.25, 0.875, and 0.75MHz. Filters are also tunable to compensate for process/temperature variation. The TX and RX filters are the same but controlled via SPI link independently. Measured amplitude responses are shown in Figure 6.

Assuming 40MHz DAC/ADC clock, 28MHz modulation bandwidth (equivalent to 14MHz baseband IQ bandwidth) and 28MHz channel spacing, performance of the TRX filters is summarised as below.

TX low pass filter:

- First DAC image attenuation >= 55dB
- Second DAC image attenuation >= 70dB

RX low pass filter

- Alias attenuation >= 50dB
- First adjacent channel attenuation >= 45 dB
- Second adjacent channel attenuation >= 70 dB

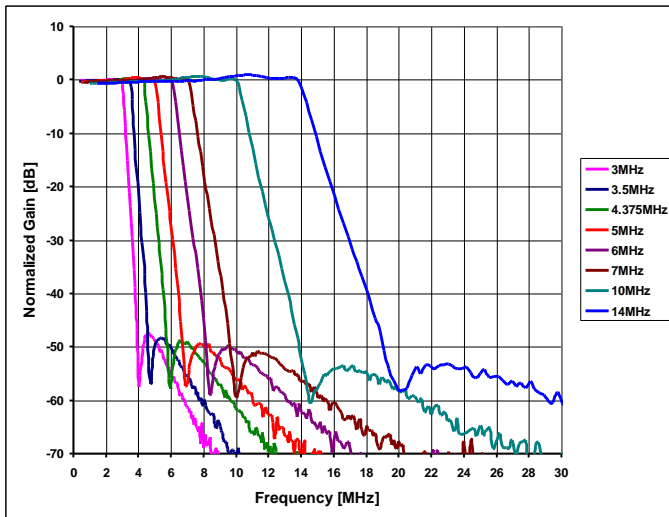
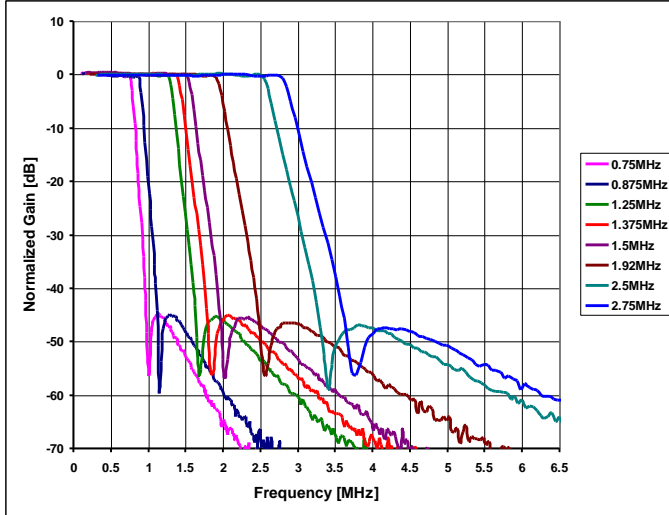

Figure 6: Measured TX/RX LPF amplitude responses

CALIBRATION AND INITIALIZATION

There are a number of calibrations which the LMS6002D can carry out internally when instructed via the SPI. These calibrations can be initiated on power up/reset to produce optimum settings. The following auto calibration options are available:

- DC offset cancellation within the various blocks
- TRX LPF bandwidth tuning

Additionally, LMS6002D provides the blocks such as LO leakage DACs and RF loop back to further facilitate the following calibrations:

- LO leakage in the transmit chain
- IQ gain and phase mismatch in both transmit and receive chains

Note that these calibrations require the loop to be closed externally via the baseband.

Recommended LMS6002D initialization sequence is as follows:

1. Apply RESET pulse (active low). This sets all the configuration registers to their default values.
2. Set target LO frequency and gain for both TX and RX chains.
3. LPF tuning
 - a. DC offset cancellation of the tuning module
 - b. Execute LPF bandwidth tuning procedure
4. TXLPF
 - a. DC offset cancellation of I filter
 - b. DC offset cancellation of Q filter
5. RXLPF
 - a. DC offset cancellation of I filter
 - b. DC offset cancellation of Q filter
6. RXVGA2
 - a. DC offset cancellation of the reference generator
 - b. DC offset cancellation of the first gain stage, I branch
 - c. DC offset cancellation of the first gain stage, Q branch
 - d. DC offset cancellation of the second gain stage, I branch
 - e. DC offset cancellation of the second gain stage, Q branch
7. TX LO leakage cancellation
8. TX IQ gain/phase error calibration
9. RX IQ gain/phase error calibration

Once the device is calibrated, register values can be stored and uploaded back into LMS6002D at the next power up/reset point which will shorten the initialization time.

Refer to “LMS6002D Programming and Calibration Guide” for more details.

DIGITAL IQ DATA INTERFACE

Description

The functionality of LMS6002D transceiver implements a subset of the LimeLight™ LMS600X-0100803¹ digital IQ interface with a 12 bit multiplexed transmit path and a 12 bit multiplexed receive path as shown in Figure 7. TX and RX interfaces require a clock running at twice the data converters sample rate. Separate clocks can be provided for the TX and RX interface. Location of the IQ samples in the multiplexed stream is flagged by the IQ select signals which are required as an input to the transmit path and provided as an output from the receive path.

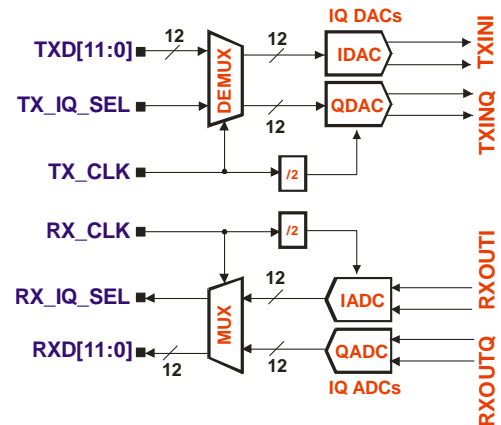

Figure 7: Baseband data interface

¹ LimeLight™ is trademark of Lime Microsystems Ltd

For both TX and RX interfaces IQ_SEL (frame sync) polarity and interleave mode are independently programmable via the SPI link, see Figure 8. Here, the frame is defined as two consecutive T(R)X_CLK, i.e. one T(R)X_IQ_SEL, periods while IQ data from the same sampling point are present on the multiplexed bus.

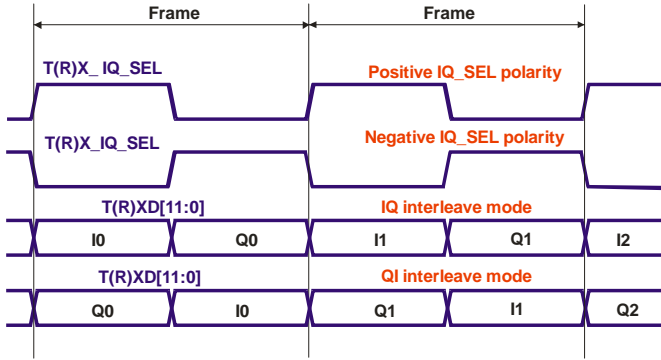

Figure 8: Frame sync polarity and interleave modes

Transmitter Data Interface

More detailed functional diagram of the TX data interface is shown in Figure 9. Corresponding waveforms are given in Figure 10. The interface is a 12 bit parallel bus from the base band IC carrying multiplexed IQ data samples for the transmit DACs. The interface data rate is twice the DACs sample rate. TX_IQ_SEL flag is used to identify I and Q samples on the multiplexed bus. Note that the DACs sampling clock is not derived by dividing TX_CLK by two as indicated in Figure 7. Instead, registered version of TX_IQ_SEL is used. Hence, for the DACs to receive sampling clock TX_IQ_SEL must be provided and toggled as in Figure 8. DACs sampling edge is also programmable via SPI link.

The TX digital IQ interface related pins are described as follows:

- TX_CLK TX interface data clock, positive edge sensitive (input)
- TXD[11:0] 12 bit multiplexed IQ data bus (input)
- TX_IQ_SEL Indicates the location of I and Q data on the multiplexed bus (input)

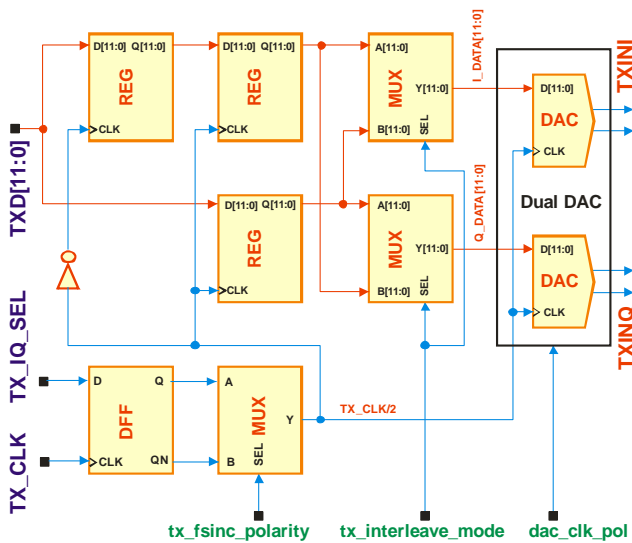

Figure 9: TX data interface

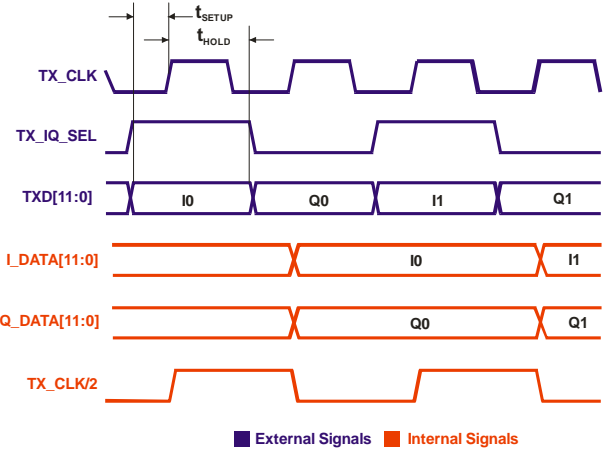

Figure 10: TX IQ interface signals

Some examples of the TX interface data rates are provided below:

- DACs sample rate
 - WCDMA 15.36 MS/s
 - GSM 1.083 MS/s
- TX IQ interface data rate
 - WCDMA 30.72 MS/s
 - GSM 2.167 MS/s

Receiver Data Interface

More detailed functional diagram of the RX data interface is shown in Figure 11. Corresponding waveforms are given in Figure 12. The interface is a 12 bit parallel bus output from the LMS6002D to the base band IC carrying multiplexed IQ data samples from the receive ADCs. The interface data rate is twice the ADCs sample rate. RX_IQ_SEL flag is provided to identify I and Q samples on the multiplexed bus. The receive clock coming from the baseband is on chip divided by two before being used by the ADC's. The ADCs sampling edge is also programmable via SPI link.

RX digital IQ interface related pins are described as follows:

- RX_CLK RX interface data clock, positive edge sensitive (input)
- RXD[11:0] 12 bit multiplexed IQ data bus (output)
- RX_IQ_SEL Indicates the location of I and Q data on the multiplexed bus (output)

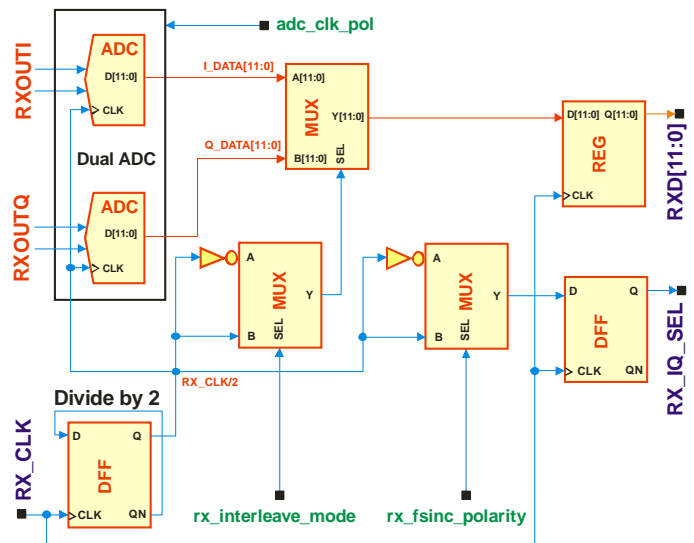

Figure 11: RX data interface

LMS6002D - Multi-band Multi-standard Transceiver with Integrated Dual DACs and ADCs

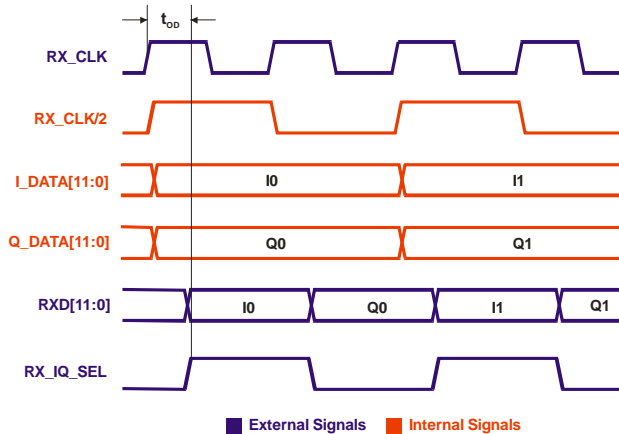

Figure 12: RX data interface signals

Some examples of the RX interface data rates are provided below:

- ADCs sample rate
 - WCDMA 15.36 MS/s
 - GSM 1.083 MS/s
- RX IQ interface data rate
 - WCDMA 30.72 MS/s
 - GSM 2.167 MS/s

IQ Interface Timing Parameters

Parameter	Min	Typ	Max	Unit
TX Setup Time (t_{SETUP})	1			ns
TX Hold Time (t_{HOLD})	0.2			ns
RX Output Delay (t_{OD}) at 15pF load			6	ns

Table 6: Digital IQ interface timing parameters at 3.3V IO supply

DACs Electrical Specifications

(At $T_A = 25^\circ\text{C}$, $T_{AVDD33} = 3.3\text{ V}$, $F_{CLK} = 40\text{ MSPS}$, $F_{OUT} = 4\text{ MHz}$, internal references, -1 dBFS input signal unless otherwise noted)

Parameter	Condition	Min	Typ	Max	Unit
Digital Core Supply		1.7	1.8	1.9	V
Analog Supply		3.1	3.3	3.5	V
Number of Bits	Two's complement format		12		bits
DAC Sampling Rate				40	MHz
Full Scale Current	Programmable		2.5		mA
Output Amplitude	At 100 Ohm differential load		250		mV _{pp} diff
SFDR			60		dBc
ENOB			10		bits

Table 7: DACs electrical specifications

ADCs Electrical Specifications

(At $T_A = 25^\circ\text{C}$, $R_{AVDD18} = 1.8\text{ V}$, $F_{CLK} = 40\text{ MSPS}$, $F_{OUT} = 4\text{ MHz}$, internal references, -1 dBFS input signal unless otherwise noted)

Parameter	Condition	Min	Typ	Max	Unit
Digital Core Supply		1.7	1.8	1.9	V
Analog Supply		1.7	1.8	1.9	V
Number of Bits	Two's complement format		12		bits
ADC Sampling Rate				40	MHz
Input Amplitude	Differential		1	1.8	V _{pp}
Input Common Mode Voltage	Input buffer off		0.9		V
Input Impedance			2		kOhm
ENOB			10		bits

Table 8: ADCs electrical specifications

Digital IQ Interface IO Buffers Specifications

Parameter	Condition	Min	Typ	Max	Unit
Supply Voltage (PVDD)	Can go below 3.3V nominal to support LV CMOS signalling	1.7	3.3	3.5	V
Input High V_{IH}		PVDD-0.8			V
Input Low V_{IL}				0.8	V
Output High V_{OH}		PVDD-0.4			V
Output Low V_{OL}				0.4	V
Input Pad Capacitance C_{IN}				3.5	pF
Output Drive Current ¹				8	mA

¹Maximum peak current that flows when the output digital lines change state and begin charging the load capacitance.

Table 9: Digital IO buffers specifications at 3.3V supply

Implementing Low Voltage Digital IQ Interface

Digital IO buffers in LMS6002D are supplied using four pins (PVDDAD33A - PVDDAD33D). All these pins must be supplied by the same supply PVDD. There is one additional supply pin (PVDDVGG) dedicated for ESD protection diodes supply. PVDDVGG must be supplied by +3.3V. However, PVDD can go below 3.3V to implement low voltage signaling. For example, if PVDD=2.5V then all data lines in Figure 13 are set to 2.5V CMOS IOs. Having PVDDVGG=3.3V sets all inputs to be 3.3V tolerant. Minimum PVDD is 1.8V.

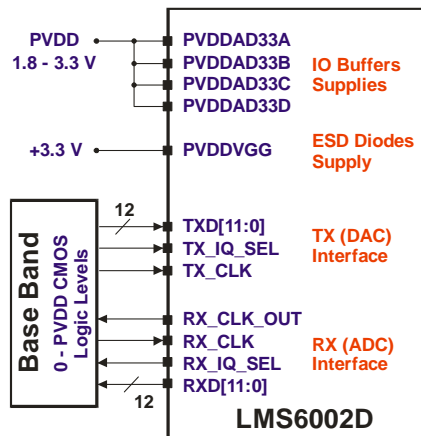

Figure 13: Digital IQ interface supplies

SERIAL PORT INTERFACE

Description

The functionality of LMS6002D transceiver is fully controlled by a set of internal registers which can be accessed through a serial port interface.

Both write and read SPI operations are supported. The serial port can be configured to run in 3 or 4 wire mode with the following pins used:

- SEN serial port enable, active low
- SCLK serial clock, positive edge sensitive
- SDIO serial data in/out in 3 wire mode
- SDO serial data input in 4 wire mode
- SDO serial data out in 4 wire mode
- SDO don't care in 3 wire mode

Serial port key features:

- 16 SPI clock cycles are required to complete write operation.
- 16 SPI clock cycles are required to complete read operation.
- Multiple write/read operations are possible without toggling serial port enable signal.

All configuration registers are 8-bit wide. Write/read sequence consists of 8-bit instruction followed by 8-bit data to write or read. MSB of the instruction bit stream is used as SPI command where CMD=1 for write and CMD=0 for read. Remaining 7 bits of the instruction represent register address.

The write/read cycle waveforms are shown in Figures 14, 15 and 16. Note that the write operation is the same for both 3-wire and 4-wire modes. Although not shown in the figures, multiple byte write/read is possible by repeating the instruction/data sequence while keeping SEN low.

SPI Timing Parameters

Parameter	Min	Typ	Max	Unit
Clock Frequency, 4-wire mode 3-wire mode			50	MHz
			20	MHz
Enable Setup Time (t_{ES})	2			ns
Enable Hold Time (t_{EH})	0.2			ns
Data Setup Time (t_{DS})	1			ns
Data Hold Time (t_{DH})	0.2			ns
Data Output Delay (t_{OD}) at 12pF load			9	ns

Table 10: SPI timing parameters at 3.3V IO supply

Write Operation

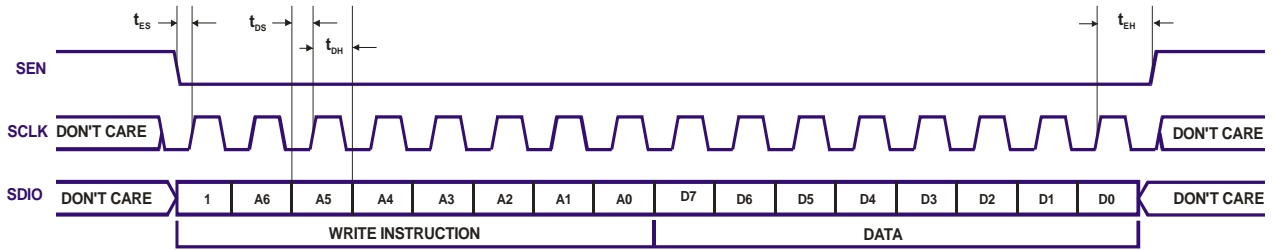

Figure 14: SPI write cycle, 3-wire and 4-wire modes

Read Operation

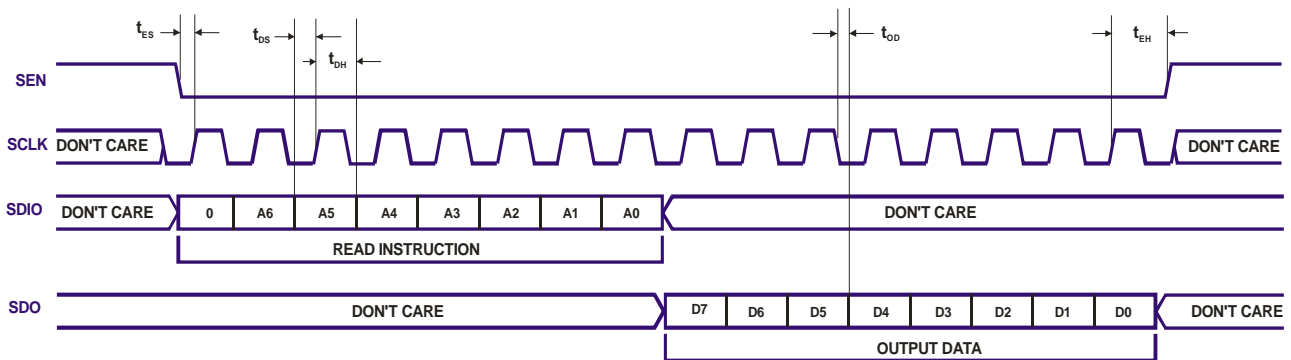

Figure 15: SPI read cycle, 4-wire mode (default)

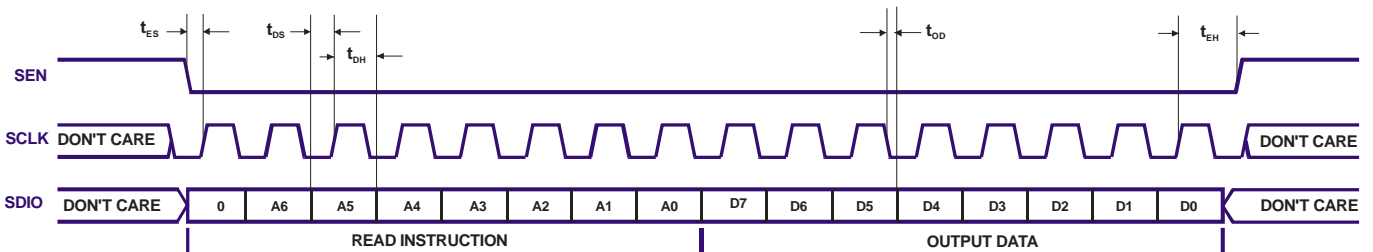

Figure 16: SPI read cycle, 3-wire mode

SPI Memory Map

The LMS6002D configuration registers are divided into eight logical blocks as shown in Table 11. 3 MSBs of the available 7-bit address are used as block address while the remaining 4 bits are used to address particular registers within the block.

010:xxxx	RX PLL
011:xxxx	TX LPF
100:xxxx	TX RF
101:xxxx	RX LPF, DACs and ADCs
110:xxxx	RX VGA2
111:xxxx	RX RF

Table 11: LMS6002D SPI memory map

Integer and fractional part of the PLL divider are stored in four bytes of configuration memory. To change their values, four write cycles are required. Hence, the controlled PLL should see new NINT and NFRAC when all four bytes are updated, otherwise it will generate unpredicted and wrong LO frequency while being configured. Such parameters are provided through a shadow register. Shadow register outputs new values only when SEN is high, i.e. there is no access to configuration memory. For that reason, DSM (PLL) SPI synchronization clock, derived from the PLL reference, must be enabled while writing to or reading from the PLL configuration registers and should last at least two cycles more after SEN goes high.

Address (7 bits)	Description
000:xxxx	Top level configuration
001:xxxx	TX PLL

Implementing Low Voltage SPI

Digital IO buffers and ESD protection diodes in the SPI region are all supplied from a single pin PVDDSPI33. PVDDSPI33 can go below 3.3V to implement low voltage signaling. For example, if PVDDSPI33=2.5V then all data lines in Figure 17, including PLL reference clock input, are set to 2.5V CMOS IOs. There is no dedicated ESD protection diodes supply here so when PVDDSPI33 is less than 3.3V, inputs will not be 3.3V tolerant. Minimum PVDDSPI33 is 1.8V.

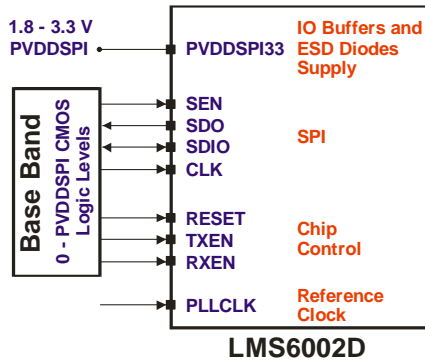

Figure 17: SPI supplies

PACKAGE OUTLINE AND PIN DESCRIPTION

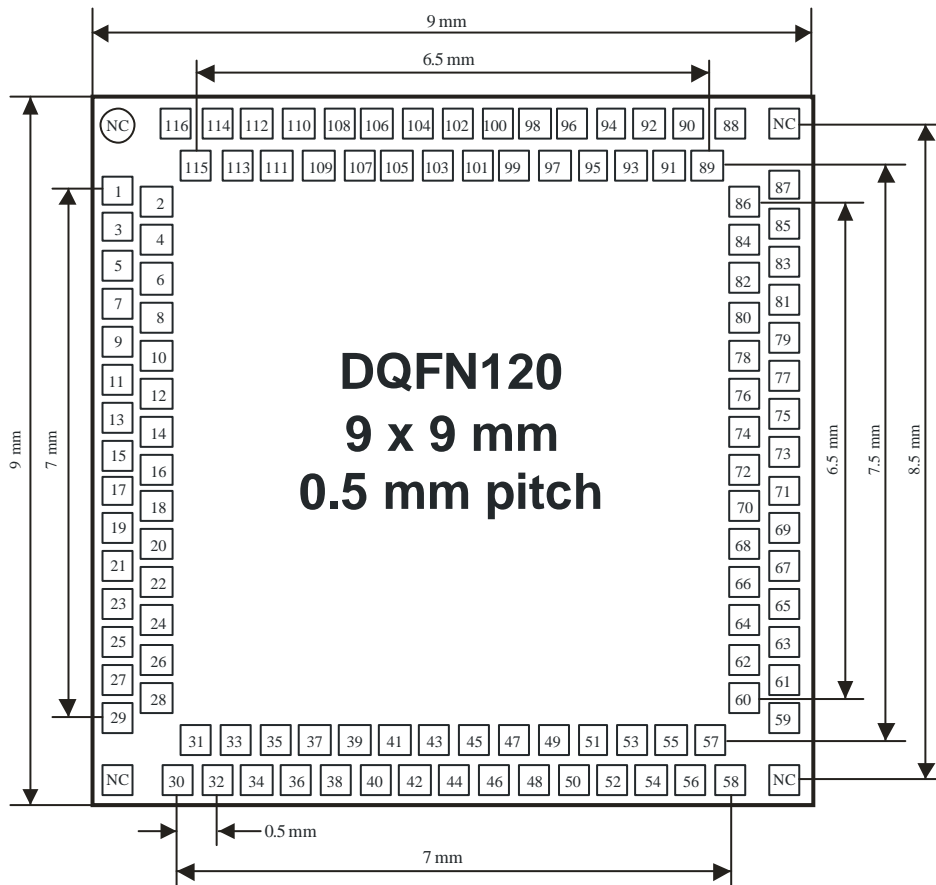

Figure 18: DQFN120 package (top view)

Pin No	Pin Name	Type	Description	Note
1	PVDDAD33A	pads supply	ADCs/DACs IOs supply (3.3V)	Can be lowered down to 1.8V to support LV signalling
2	RXD11	out cmos	ADCs digital output, bit 11 (MSB)	Two's complement
3	RXD10	out cmos	ADCs digital output, bit 10	
4	RXD9	out cmos	ADCs digital output, bit 9	
5	RXD8	out cmos	ADCs digital output, bit 8	
6	RXD7	out cmos	ADCs digital output, bit 7	
7	PVDDVGG	esd supply	ADCs/DACs IOs ESD supply (3.3V)	
8	RXD5	out cmos	ADCs digital output, bit 5	
9	RXD6	out cmos	ADCs digital output, bit 6	
10	RXD3	out cmos	ADCs digital output, bit 3	
11	RXD4	out cmos	ADCs digital output, bit 4	
12	PVDDAD33B	pads supply	ADCs/DACs IOs supply (3.3V)	Can be lowered down to 1.8V to support LV signalling
13	RXD2	out cmos	ADCs digital output, bit 2	
14	RXD1	out cmos	ADCs digital output, bit 1	
15	RXD0	out cmos	ADCs digital output, bit 0 (LSB)	
16	RX_IQ_SEL	out cmos	RX digital interface IQ flag	
17	RX_CLK	in cmos	RX digital interface clock	
18	PVDDAD33C	pads supply	ADCs/DACs IOs supply (3.3V)	Can be lowered down to 1.8V to support LV signalling
19	TX_CLK	in cmos	TX digital interface clock	
20	TX_IQ_SEL	in cmos	TX digital interface IQ flag	
21	TXD0	in cmos	DACs digital input, bit 0 (LSB)	
22	TXD1	in cmos	DACs digital input, bit 1	
23	TXD2	in cmos	DACs digital input, bit 2	
24	TXD3	in cmos	DACs digital input, bit 3	
25	TXD4	in cmos	DACs digital input, bit 4	
26	TXD5	in cmos	DACs digital input, bit 5	
27	TXD6	in cmos	DACs digital input, bit 6	
28	TXD7	in cmos	DACs digital input, bit 7	
29	TXD8	in cmos	DACs digital input, bit 8	
30	TXD9	in cmos	DACs digital input, bit 9	
31	TXD10	in cmos	DACs digital input, bit 10	
32	TXD11	in cmos	DACs digital input, bit 11 (MSB)	Two's complement
33	RDVDD18	digital supply	ADCs digital supply (1.8V)	
34	PVDDAD33D	pads supply	ADCs/DACs pads supply (3.3V)	Can be lowered down to 1.8V to support LV signalling
35	RAVDD18	analogue supply	ADCs analogue supply (1.8V)	
36	TDVDD18	digital supply	DACs digital supply (1.8V)	
37	TAVDD33	analogue supply	DACs analogue supply (3.3V)	
38	VREFAD	in/out	External capacitor for ADCs/DACs (>100nF)	
39	XRESAD	in/out	External resistor for ADCs/DACs	
40	RX_CLK_OUT	out cmos	Buffered RX_CLK (ADCs) clock, CMOS level	Can be used to align RXD[11:0] sampling clock in BB.
41	PLLCLKOUT	out cmos	Buffered PLLCLK (PLL reference) clock, CMOS level	Can be used as BB clock.
42	ATP	out	Analogue test point	
43	TXVCLPF33	analogue supply	TXLPF supply (3.3V)	
44	TXOUT2N	out	TX output 2, negative	
45	TXVCCMIX33	analogue supply	TXMIX supply (3.3V)	
46	TXOUT2P	out	TX output 2, positive	
47	TXPVDD33	esd supply	TX pads ESD supply (3.3V)	
48	TXOUT1P	out	TX output 1, positive	
49	TXVCCDRV33	analogue supply	TXVGA2 supply (3.3V)	
50	TXOUT1N	out	TX output 1, negative	
51	TXININ	in/out	TXDAC output / TXLPF input	
52	TXINIP	in/out	TXDAC output / TXLPF input	
53	UNUSED			Connect to ground
54	TXINQP	in/out	TXDAC output / TXLPF input	
55	UNUSED			Connect to ground
56	TXINQN	in/out	TXDAC output / TXLPF input	
57	TXVTUNE	in/out	TXPLL loop filter output	
58	TXPVDDPLL33A	esd supply	TXPLL pads ESD supply (3.3V)	
59	TXVCCVCO33	analogue supply	TXPLL 3.3V supply (3.3V)	
60	TXVDDVCO18	analogue supply	TXPLL VCO supply (1.8V)	

Table 12: Pin descriptions

Pin No	Pin Name	Type	Description	Note
61	TXVCCPLL18	digital supply	TX PLL modules 1.8V supply (1.8V)	
62	TXPVDDPLL33B	esd supply	TX PLL pads ESD supply (3.3V)	
63	TXVCCCHP33	analogue supply	TX PLL charge pump supply (3.3V)	
64	TXCPOUT	in/out	Transmit PLL loop filter input	
65	TSTD_out1	out cmos	TX and RX PLLs digital test point	
66	TXEN	in cmos	Transmitter enable, active high	
67	SEN	in cmos	Serial port enable, active low	
68	SDO	out cmos	Serial port data out	High Z when SEN=1
69	SDIO	in/out cmos	Serial port data in/out	
70	SCLK	in cmos	Serial port clock, positive edge sensitive	
71	PLLCLK	in, cmos or clipped sine	PLL reference clock input (23MHz - 41 MHz)	Minimum input level is 0.2Vpp. Both DC and AC coupling supported.
72	TRXVDDDSM18	digital supply	Delta sigma digital core supply (1.8V)	
73	VSP18	digital supply	SPI digital core supply (1.8V)	
74	PVDDSPI33	esd supply	SPI pads and ESD Supply (3.3V)	Can be lowered down to 1.8V to support LV signalling
75	RESET	in cmos	Hardware reset, active low	
76	RXEN	in cmos	Receiver enable, active high	
77	TSTD_out2	out cmos	TX and RX PLLs digital test point	
78	RXVCCCHP33	analogue supply	RXPLL charge pump supply (3.3V)	
79	RXVCCLOB33	analogue supply	RXPLL LO buffer supply (3.3V)	
80	RXCPOUT	in/out	RXPLL loop filter input	
81	RXPVDDPLL33B	esd supply	RXPLL pads ESD supply (3.3V)	
82	RXVCCVCO33	analogue supply	RXPLL 3.3V supply (3.3V)	
83	RXVCCPLL18	digital supply	RXPLL 1.8V supply (1.8V)	
84	RXVDDVCO18	analogue supply	RX PLL VCO supply (1.8V)	
85	RXVCCPLL33	analogue supply	RX PLL 3.3V supply	
86	RXPVDDPLL33A	esd supply	RXPLL pads ESD supply (3.3V)	
87	RXVTUNE	in/out	RXPLL loop filter output	
88	UNUSED			Connect to ground
89	XRES12k	in/out	External 12k 1% resistor to ground	
90	RXVCCMIX33	analogue supply	RMIX supply (3.3V)	
91	OEXLNA1P	out	LNA1 output positive	
92	IEXMIX1P	in	Mixer input 1 positive	
93	UNUSED			Connect to ground
94	IEXMIX1N	in	Mixer input 1 negative	
95	OEXLNA1N	out	LNA1 output negative	
96	RXIN1P	in	RX1 (LNA1) input	
97	RXIN1EP	in	LNA1 external emitter inductance	Connect to ground
98	RXIN1N	in	RX1 (LNA1) input	
99	RXIN1EN	in	LNA1 external emitter inductance	Connect to ground
100	RXIN2P	in	RX2 (LNA2) input	
101	RXVCCLNA33	analogue supply	RX LNA supply (3.3V)	
102	RXIN2N	in	RX2 (LNA2) input	
103	OEXLNA2P	out	LNA2 output positive	
104	IEXMIX2P	in	Mixer input 2 positive	
105	OEXLNA2N	out	LNA 2 output negative	
106	IEXMIX2N	in	Mixer input 2 negative	
107	RXPVDD33	esd supply	RX pads ESD supply (3.3V)	
108	RXIN3P	in	RX3 (LNA3) input	
109	RXVCCVGA33	analogue supply	RXTIA (RXVGA1) supply (3.3V)	
110	RXIN3N	in	RX3 (LNA3) input	
111	RXVCCLPF33	analogue supply	RXLPF supply (3.3V)	
112	RXVCCVGA33	analogue supply	RXVGA2 supply (3.3V)	
113	RXOUTQP	in/out	RXVGA2 output / RX ADC input	
114	RXOUTQN	in/out	RXVGA2 output / RX ADC input	
115	RXOUTIN	in/out	RX VGA2 output / RX ADC input	
116	RXOUTIP	in/out	RX VGA2 output / RX ADC input	
117	GLOBAL GND	GLOBAL GND	Package paddle ground	

Table 12: Pin descriptions (continued)

TYPICAL APPLICATION

Typical application circuit of LMS6002D is given in Figure 19. Note that only RF part is shown. It is recommended all unused pins to be grounded, digital test pins should be left open while RF pins should

be connected as in Figure 19. As shown, RF ports are matched for UMTS bands I and V while TXOUT2 and RXIN3 are broadband matched. Refer to “LMS6002D Reference Design and PCB Layout Recommendations” for more details.

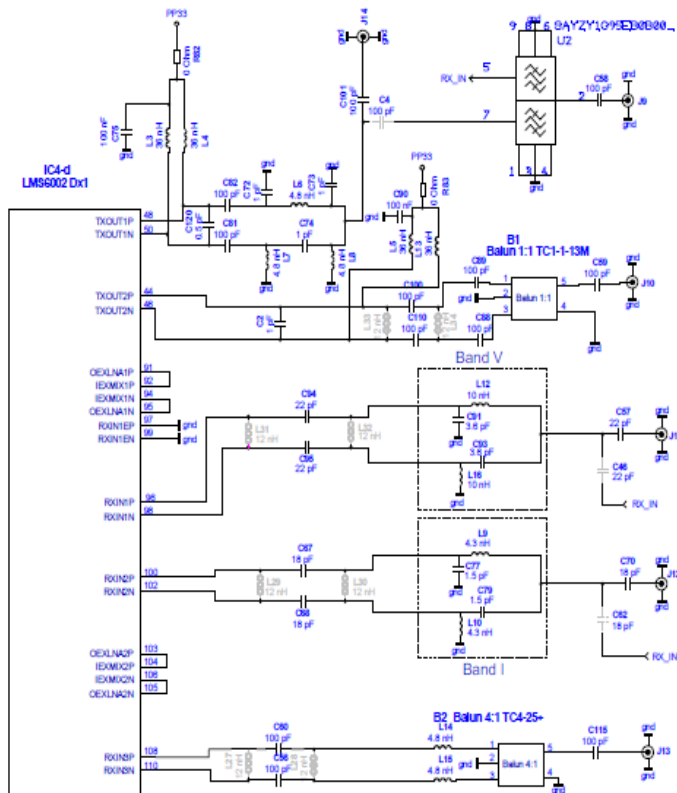

Figure 19: LMS6002D Typical Application Circuit Diagram – RF part

Looking for pricing, stock, or lifecycle information?

Click below to explore more details on WIN SOURCE:

- [View LMS6002DFN on WIN SOURCE](#)
- [Lime Microsystems Ltd Information](#)

Optimize Your Supply Chain with WIN SOURCE Solutions

- ✓ Global Sourcing Solution
- ✓ Obsolete Management
- ✓ Cost Control Management
- ✓ Shortage Management
- ✓ Alternative Solution
- ✓ Excess Inventory Management