



**THE DATASHEET OF
LMR64010XMFDEMO/NOPB**



AN-2183 LMR62014/LMR64010 Demo Board

Trademarks

All trademarks are the property of their respective owners.

1 Introduction

The Texas Instruments LMR62014 and LMR64010 are high frequency switching boost regulators that offer small size and high power conversion efficiency. The parts operate at a 1.6MHz switching frequency. The primary difference between the LMR62014 and LMR64010 is that the LMR62014 has a higher current internal switch FET (with lower breakdown voltage), while the LMR64010 has a higher voltage FET which handles less current. The LMR64010 targets applications with higher output voltages, while the LMR62014 is intended for applications requiring higher load currents at lower output voltages. This user's guide describes the demo board supplied to demonstrate the operation of these parts and give information on its usage. This Demo Board is intended to be used at an ambient temperature of 25°C.

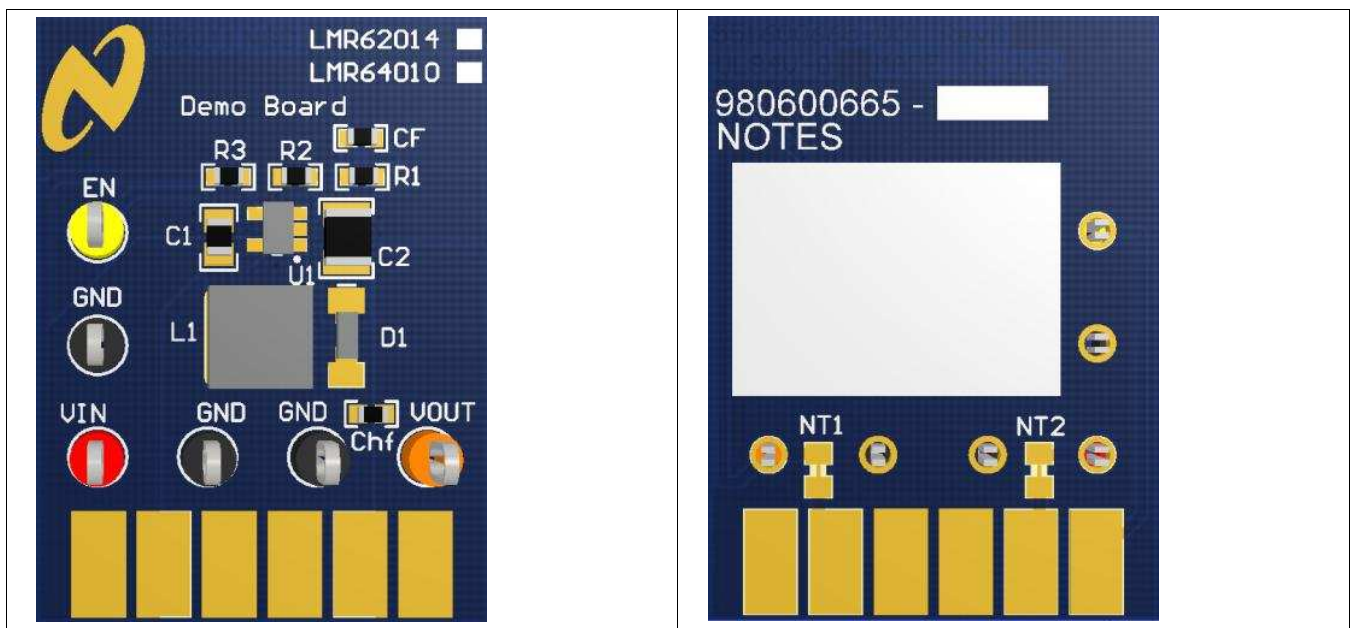

Figure 3. LMR62014/LMR64010 Demo Board

2 Features

- 2.7V to 12V Input Voltage Range
- 12V Output Voltage, and 450mA Output Current from 5V input supply (LMR62014)
- 24V Output Voltage, and 125mA Output Current from 5V input supply (LMR64010)
- Switching Frequency of 1.6 MHz
- Minimal Component Count
- Small Solution Size (12mm × 17mm)

3 Shutdown Operation

The demo board includes a pull-up resistor R3 to enable the device once V_{IN} has exceeded 1.5V. Use the EN post to disable the device by pulling this node to GND. A logic signal may be applied to the post to test startup and shutdown of the device.

4 Adjusting the Output Voltage

The output voltage can be changed from 12V/24V to another voltage by adjusting the feedback resistors using the following equation:

$$V_{OUT} = V_{FB}(1 + (R1/R2)) \quad (1)$$

Where V_{FB} is 1.23V.

5 Feedforward Compensation

The feedforward capacitor CF should be selected to set the compensation zero at approximately 8 kHz. The value of CF is calculated using:

$$CF = 1 / (2 \times \pi \times 8k \times R1) \quad (2)$$

The value of CF is calculated after R1 is selected for the output voltage needed for the specific application.

For more information on component selection and features, see:

- *LMR62014 SIMPLE SWITCHER 20Vout, 1.4A Step-Up Voltage Regulator in SOT-23* ([SNVS735](#))
- *LMR64010 SIMPLE SWITCHER 40Vout, 1A Step-Up Voltage Regulator in SOT-23* ([SNVS736](#))

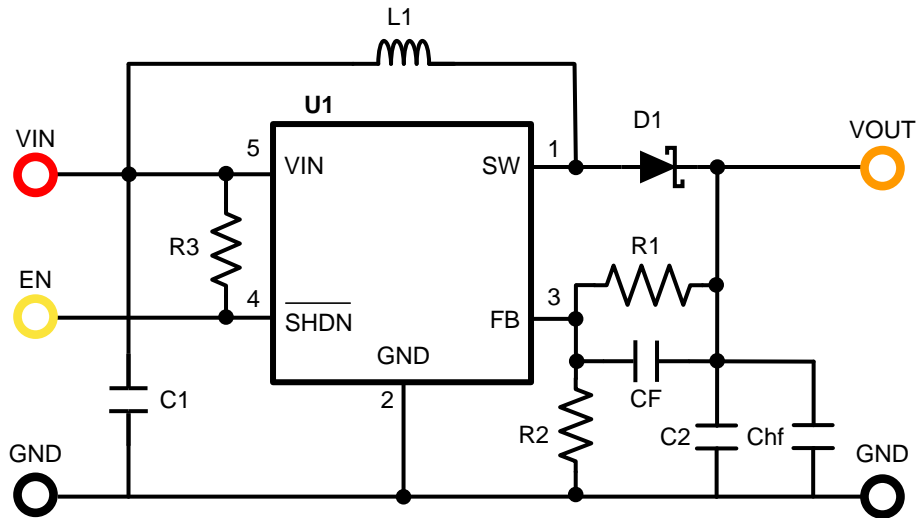
6 LMR62014 Demo Board Schematic

Figure 4. LMR62014 Demo Board Schematic
Table 1. Bill of Materials LMR62014

ID	Part Number	Type	Size	Parameters	Qty	Vendor
U1	LMR62014	Boost Regulator	SOT-23		1	Texas Instruments
L1	NR6045T100M	Inductor	SMD	10uH, 2.5A, 0.061 ohm,	1	Sumida
D1	CRS08	Diode	S-Flat	Schottky, 30V, 1.5A	1	Toshiba
C1	GRM21BR71C225KA12L	Capacitor	0805	Ceramic, 2.2uF, 16V, X7R	1	Murata
C2	GRM32ER71H475KA88L	Capacitor	1210	Ceramic, 4.7uF, 50V, X7R	1	Murata
CF	C0603C221J5GACTU	Capacitor	0603	Ceramic, 220pF, 50V, C0G/NP0	1	Kemet
CHF	GRM188R71H223KA01D	Capacitor	0603	Ceramic, 0.022uF, 50V, X7R	1	Murata
R1	CRCW0603115KFKEA	Resistor	0603	115 kΩ	1	Vishay
R2	CRCW060313K3FKEA	Resistor	0603	13.3 kΩ	1	Vishay
R3	CRCW06031M00JNEA	Resistor	0603	1.0 MegΩ	1	Vishay
EN	5014	Test Point Loop		Yellow	1	Keystone
VIN	5010	Test Point Loop		Red	1	Keystone
VOUT	5013	Test Point Loop		Orange	1	Keystone
GND	5011	Test Point Loop		Black	2	Keystone

7 LMR64010 Demo Board Schematic

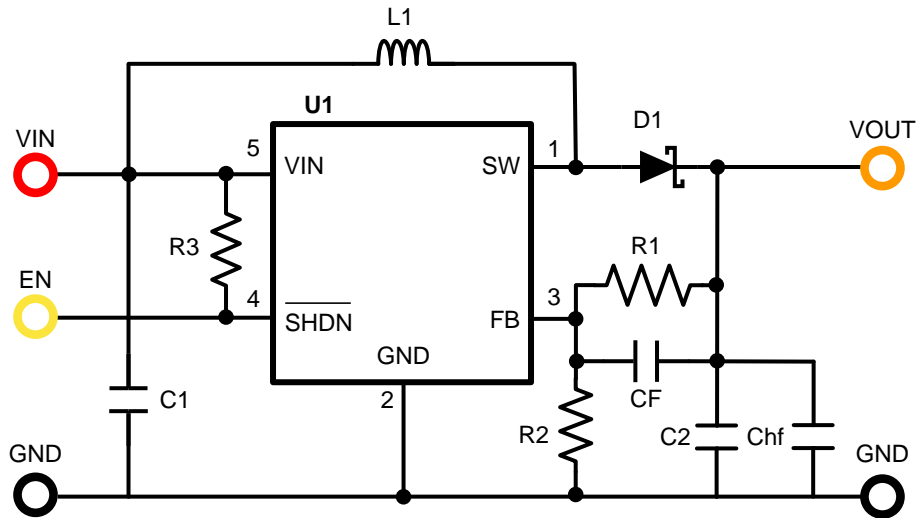

Figure 5. LMR64010 Demo Board Schematic

Table 2. Bill of Materials LMR64010

ID	Part Number	Type	Size	Parameters	Qty	Vendor
U1	LMR64010	Boost Regulator	SOT-23		1	Texas Instruments
L1	NR6045T100M	Inductor	SMD	10uH, 2.5A, 0.061 ohm,	1	Sumida
D1	CRS04	Diode	S-Flat	Schottky, 40V, 1.0A	1	Toshiba
C1	GRM21BR71C225KA12L	Capacitor	0805	Ceramic, 2.2uF, 16V, X7R	1	Murata
C2	GRM32ER71H475KA88L	Capacitor	1210	Ceramic, 4.7uF, 50V, X7R	1	Murata
CF	C0603C121J5GACTU	Capacitor	0603	Ceramic, 120pF, 50V, C0G/NP0	1	Kemet
CHF	GRM188R71H223KA01D	Capacitor	0603	Ceramic, 0.022uF, 50V, X7R	1	Murata
R1	CRCW0603243KFKEA	Resistor	0603	243 kΩ	1	Vishay
R2	CRCW060313K3FKEA	Resistor	0603	13.3 kΩ	1	Vishay
R3	CRCW06031M00JNEA	Resistor	0603	1.0 MegΩ	1	Vishay
EN	5014	Test Point Loop		Yellow	1	Keystone
VIN	5010	Test Point Loop		Red	1	Keystone
VOUT	5013	Test Point Loop		Orange	1	Keystone
GND	5011	Test Point Loop		Black	2	Keystone

8 Quick Setup Procedures

8.1 LMR62014

Step 1: Connect a power supply to VIN terminals

Step 2: Connect a load to VOUT terminals

Step 3: EN terminal should be left floating for normal operation. Short this to ground to shutdown the part

Step 4: Set VIN = 5V, with 0A load applied, check VOUT with a voltmeter. Nominal 11.9V

Step 5: Apply a 450mA load and check VOUT. Nominal 11.9V

8.2 LMR64010

Step 1: Connect a power supply to VIN terminals

Step 2: Connect a load to VOUT terminals

Step 3: EN terminal should be left floating for normal operation. Short this to ground to shutdown the part

Step 4: Set VIN = 5V, with 0A load applied, check VOUT with a voltmeter. Nominal 23.7V

Step 5: Apply a 125mA load and check VOUT. Nominal 23.5V

9 Measurements

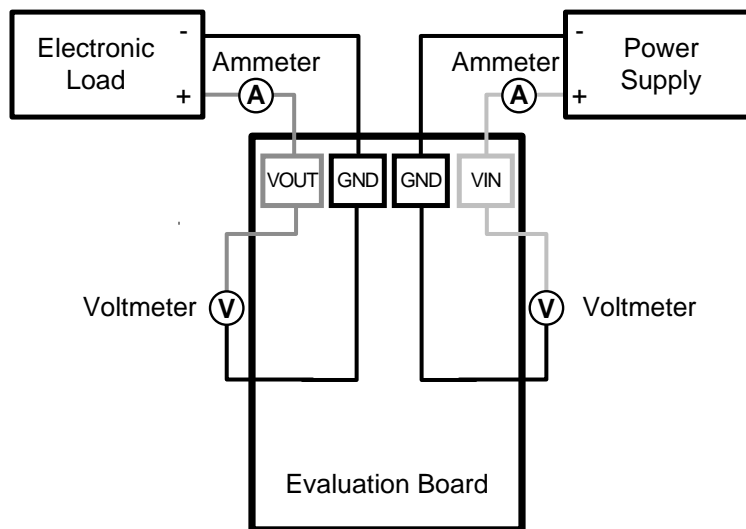

Figure 6. Efficiency Measurements

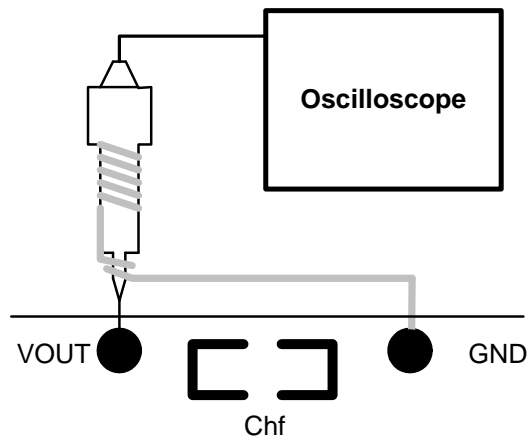

Figure 7. Voltage Ripple Measurements

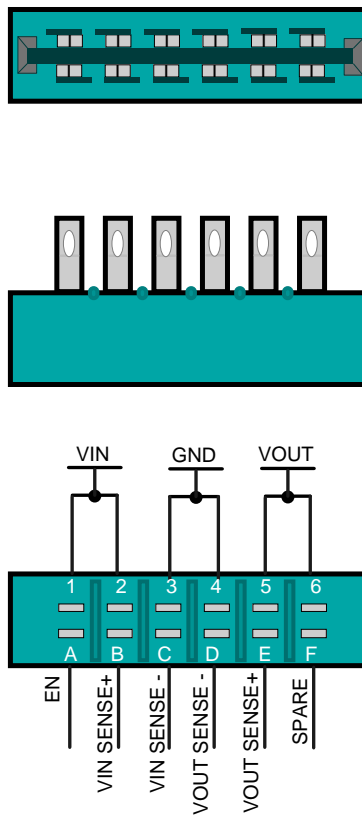

Figure 8. Edge Connector Schematic

10 Typical Performance Characteristics

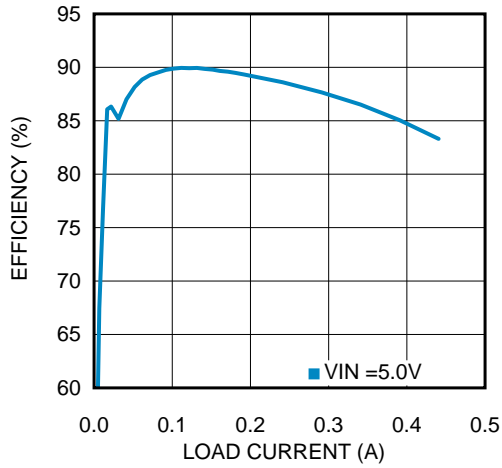

Figure 9. Efficiency vs. Load Current LMR62014, VOUT = 12V

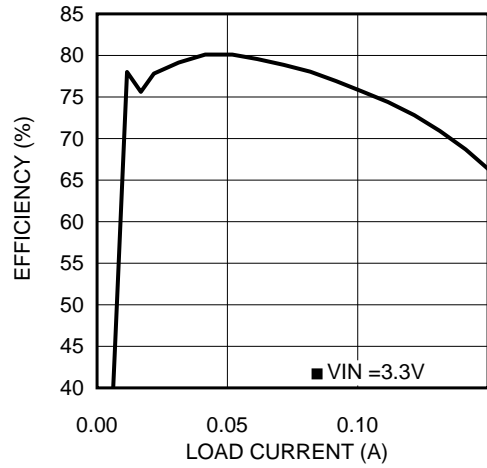

Figure 10. Efficiency vs. Load Current LMR62014, VOUT = 12V

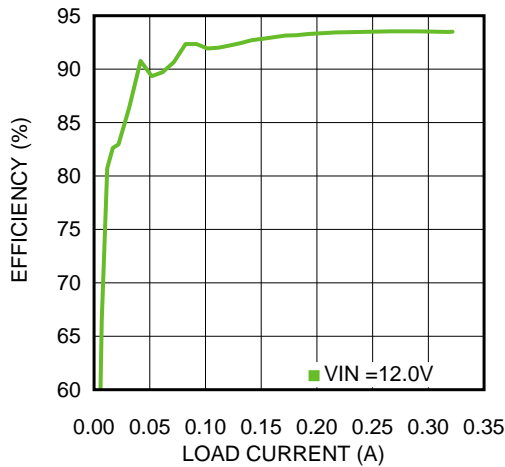

Figure 11. Efficiency vs. Load Current LMR64010, VOUT = 24V

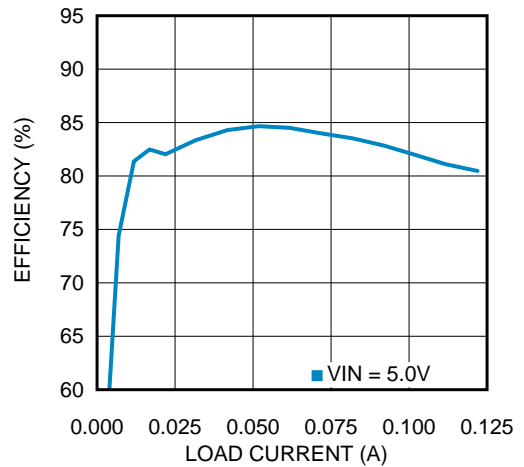

Figure 12. Efficiency vs. Load Current LMR64010, VOUT = 24V

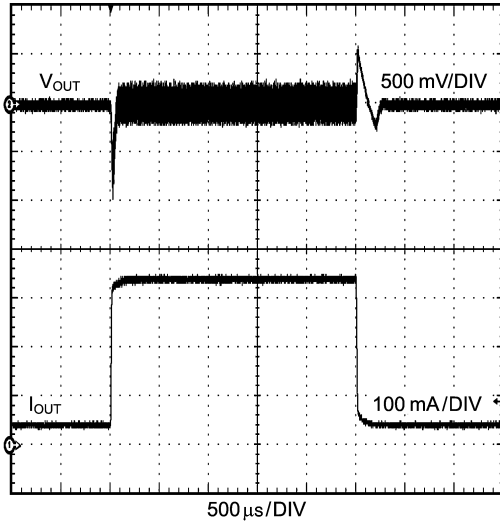

Figure 13. Load Transient Waveforms LMR62014
IOUT = 33 to 330mA

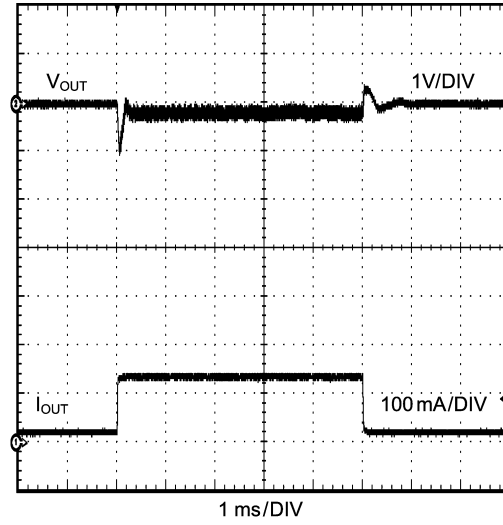

Figure 14. Load Transient Waveforms LMR64010
IOUT = 13 to 125mA

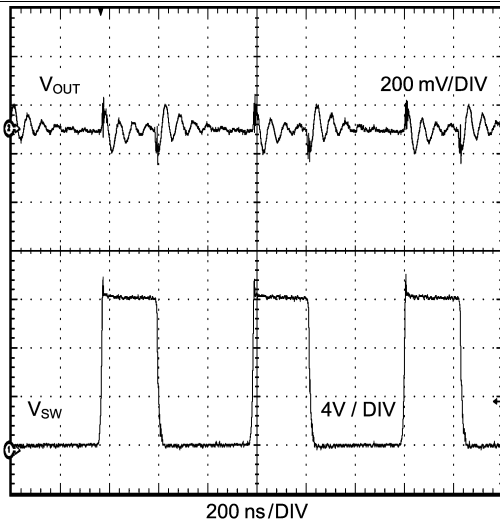

Figure 15. Switching Node and Output Voltage Waveforms
LMR62014

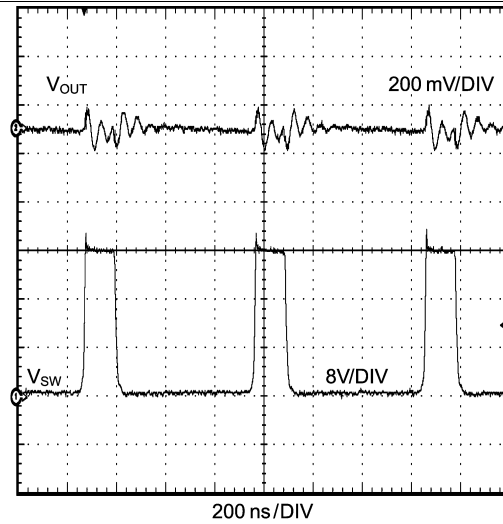

Figure 16. Switching Node and Output Voltage Waveforms
LMR64010

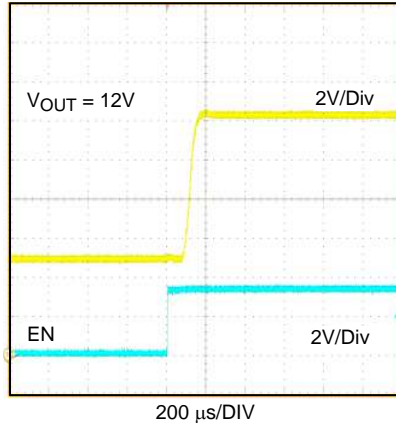

Figure 17. Startup Waveform

11 Layout

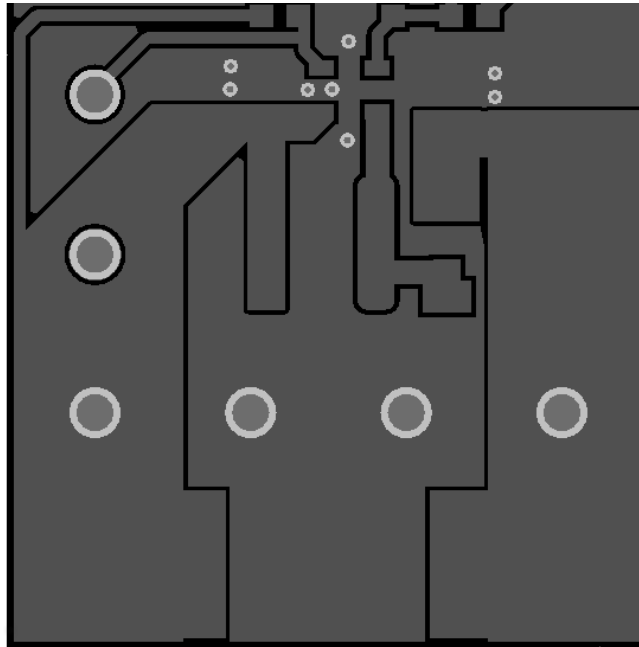

Figure 18. Top Layer

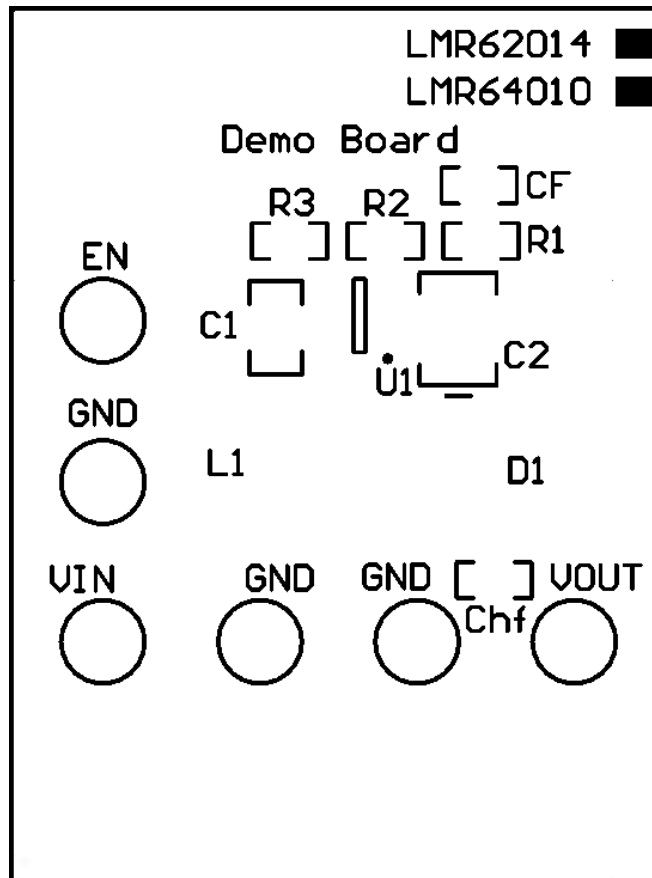

Figure 19. Top Overlay

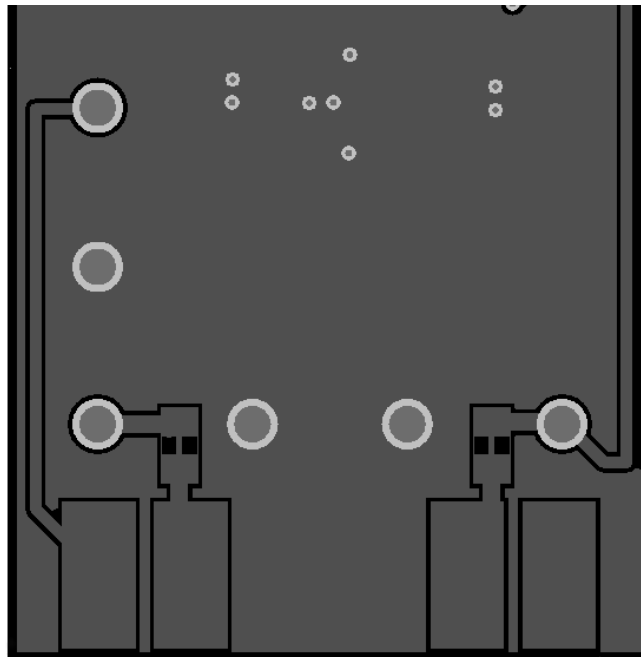

Figure 20. Bottom Layer

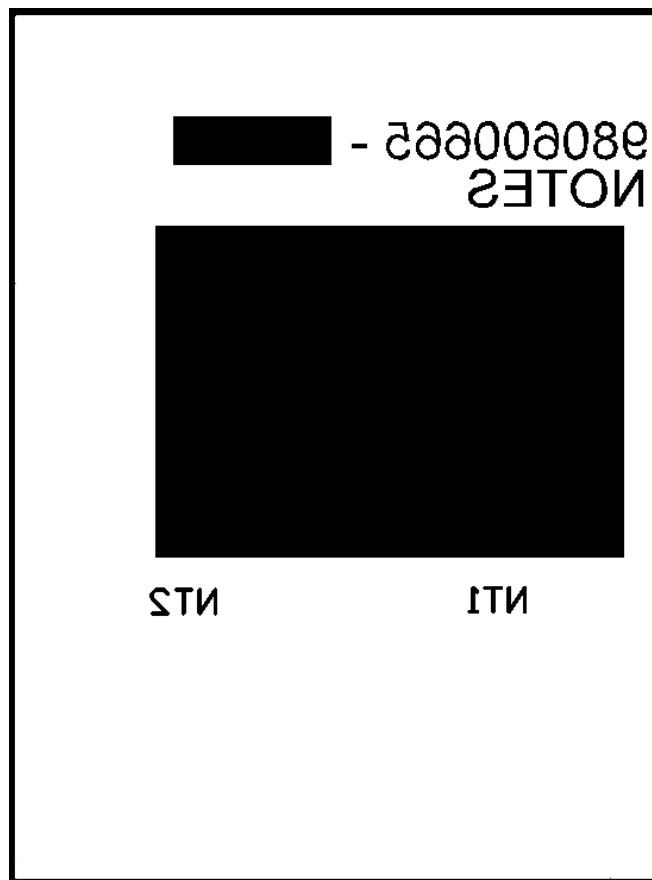

Figure 21. Bottom Overlay

Revision History

NOTE: Page numbers for previous revisions may differ from page numbers in the current version.

Changes from A Revision (April 2013) to B Revision	Page
• Added text to introduction	1
• Changed Typical Performance Characteristics from titles to figure numbers	7

IMPORTANT NOTICE FOR TI DESIGN INFORMATION AND RESOURCES

Texas Instruments Incorporated ("TI") technical, application or other design advice, services or information, including, but not limited to, reference designs and materials relating to evaluation modules, (collectively, "TI Resources") are intended to assist designers who are developing applications that incorporate TI products; by downloading, accessing or using any particular TI Resource in any way, you (individually or, if you are acting on behalf of a company, your company) agree to use it solely for this purpose and subject to the terms of this Notice.

TI's provision of TI Resources does not expand or otherwise alter TI's applicable published warranties or warranty disclaimers for TI products, and no additional obligations or liabilities arise from TI providing such TI Resources. TI reserves the right to make corrections, enhancements, improvements and other changes to its TI Resources.

You understand and agree that you remain responsible for using your independent analysis, evaluation and judgment in designing your applications and that you have full and exclusive responsibility to assure the safety of your applications and compliance of your applications (and of all TI products used in or for your applications) with all applicable regulations, laws and other applicable requirements. You represent that, with respect to your applications, you have all the necessary expertise to create and implement safeguards that (1) anticipate dangerous consequences of failures, (2) monitor failures and their consequences, and (3) lessen the likelihood of failures that might cause harm and take appropriate actions. You agree that prior to using or distributing any applications that include TI products, you will thoroughly test such applications and the functionality of such TI products as used in such applications. TI has not conducted any testing other than that specifically described in the published documentation for a particular TI Resource.

You are authorized to use, copy and modify any individual TI Resource only in connection with the development of applications that include the TI product(s) identified in such TI Resource. NO OTHER LICENSE, EXPRESS OR IMPLIED, BY ESTOPPEL OR OTHERWISE TO ANY OTHER TI INTELLECTUAL PROPERTY RIGHT, AND NO LICENSE TO ANY TECHNOLOGY OR INTELLECTUAL PROPERTY RIGHT OF TI OR ANY THIRD PARTY IS GRANTED HEREIN, including but not limited to any patent right, copyright, mask work right, or other intellectual property right relating to any combination, machine, or process in which TI products or services are used. Information regarding or referencing third-party products or services does not constitute a license to use such products or services, or a warranty or endorsement thereof. Use of TI Resources may require a license from a third party under the patents or other intellectual property of the third party, or a license from TI under the patents or other intellectual property of TI.

TI RESOURCES ARE PROVIDED "AS IS" AND WITH ALL FAULTS. TI DISCLAIMS ALL OTHER WARRANTIES OR REPRESENTATIONS, EXPRESS OR IMPLIED, REGARDING TI RESOURCES OR USE THEREOF, INCLUDING BUT NOT LIMITED TO ACCURACY OR COMPLETENESS, TITLE, ANY EPIDEMIC FAILURE WARRANTY AND ANY IMPLIED WARRANTIES OF MERCHANTABILITY, FITNESS FOR A PARTICULAR PURPOSE, AND NON-INFRINGEMENT OF ANY THIRD PARTY INTELLECTUAL PROPERTY RIGHTS.

TI SHALL NOT BE LIABLE FOR AND SHALL NOT DEFEND OR INDEMNIFY YOU AGAINST ANY CLAIM, INCLUDING BUT NOT LIMITED TO ANY INFRINGEMENT CLAIM THAT RELATES TO OR IS BASED ON ANY COMBINATION OF PRODUCTS EVEN IF DESCRIBED IN TI RESOURCES OR OTHERWISE. IN NO EVENT SHALL TI BE LIABLE FOR ANY ACTUAL, DIRECT, SPECIAL, COLLATERAL, INDIRECT, PUNITIVE, INCIDENTAL, CONSEQUENTIAL OR EXEMPLARY DAMAGES IN CONNECTION WITH OR ARISING OUT OF TI RESOURCES OR USE THEREOF, AND REGARDLESS OF WHETHER TI HAS BEEN ADVISED OF THE POSSIBILITY OF SUCH DAMAGES.

You agree to fully indemnify TI and its representatives against any damages, costs, losses, and/or liabilities arising out of your non-compliance with the terms and provisions of this Notice.

This Notice applies to TI Resources. Additional terms apply to the use and purchase of certain types of materials, TI products and services. These include; without limitation, TI's standard terms for semiconductor products (<http://www.ti.com/sc/docs/stdterms.htm>), [evaluation modules](#), and [samples](http://www.ti.com/sc/docs/sampterm.htm) (<http://www.ti.com/sc/docs/sampterm.htm>).

Mailing Address: Texas Instruments, Post Office Box 655303, Dallas, Texas 75265
Copyright © 2017, Texas Instruments Incorporated

Looking for pricing, stock, or lifecycle information?

Click below to explore more details on WIN SOURCE:

- ⊖ [View LMR64010XMFDEMO/NOPB on WIN SOURCE](#)
- ⊖ [Texas Instruments](#) Information

Optimize Your Supply Chain with WIN SOURCE Solutions

- ✓ Global Sourcing Solution
- ✓ Obsolete Management
- ✓ Cost Control Management
- ✓ Shortage Management
- ✓ Alternative Solution
- ✓ Excess Inventory Management