

LMH0356 3-Gbps HD/SD SDI Reclocker with 4:1 Input Mux and FR4 EQs

1 Features

- Supports SMPTE ST-424, ST-292, and ST-259 Serial Digital Video Standards
- Supports 270-Mbps, 1.483-Gbps, 1.485-Gbps, 2.967-Gbps, and 2.97-Gbps Serial Data Rate Operation
- Supports DVB-ASI at 270 Mbps
- Single 3.3-V Supply Operation
- 430-mW Typical Power Consumption
- Integrated 4:1 Multiplexed Input
- 0 to 30-inch FR4 Equalizer on Each Multiplexed Input
- Two Differential, Reclocked Outputs
- Choice of Second Reclocked Output or Recovered Clock Output
- Single 27-MHz External Crystal or Reference Clock Input
- Manual Rate Select Input
- SD/HD Operating Rate Indicator Output
- Lock Detect Indicator Output
- Output Mute Function for Data and Clock
- Auto/Manual Reclocker Bypass
- Power Saver Mode With Device Power-Down Control (10-mW Typical Power Consumption in Disabled State)
- Differential LVPECL-Compatible Serial Data Inputs and Outputs
- LVCMOS Control Inputs and Indicator Outputs
- 48-Pin WQFN or 40-Pin WQFN Package
- Industrial Temperature Range: -40°C to 85°C
- 48-Pin WQFN Version Footprint-Compatible with the LMH0056 and LMH0036

2 Applications

- SDTV/HDTV and 3-Gbps Serial Digital Video Interfaces for:
 - Digital Video Routers and Switchers
 - Digital Video Processing and Editing Equipment
 - DVB-ASI Equipment
 - Video Standards and Format Converters

3 Description

The LMH0356 3-Gbps HD/SD SDI Reclocker with 4:1 Input Mux and FR4 EQs retimes serial digital video data conforming to the SMPTE ST-424, ST-292, and ST-259 standards. The LMH0356 operates at serial data rates of 270 Mbps, 1.483 Gbps, 1.485 Gbps, 2.967 Gbps, and 2.97 Gbps. The LMH0356 supports DVB-ASI operation at 270 Mbps. The LMH0356 includes an integrated 4:1 input multiplexer for selecting one of four input data streams for retiming. In addition, the four inputs of the LMH0356 each have an FR4 equalizer capable of equalizing 0 to 30 inches of FR4 trace length.

The LMH0356 automatically detects the incoming data rate and adjusts itself to retime the incoming data to suppress accumulated jitter. The LMH0356 recovers the serial data-rate clock and optionally provides it as an output. The LMH0356 has two differential serial data outputs; the second output may be selected as a low-jitter, data-rate clock output. Controls and indicators are: serial clock or second serial data output select, manual rate select input, SD/HD rate indicator output, lock detect output, auto/manual data bypass, output mute, and device enable. The serial data inputs, outputs, and serial clock outputs are differential LVPECL compatible. The CML serial data and serial clock outputs are suitable for driving 100- Ω differentially terminated networks. The control logic inputs and outputs are LVCMOS compatible.

Device Information⁽¹⁾

PART NUMBER	PACKAGE	BODY SIZE (NOM)
LMH0356	WQFN (40)	5.00 mm x 5.00 mm
	WQFN (48)	7.00 mm x 7.00 mm

(1) For all available packages, see the orderable addendum at the end of the data sheet.

Functional Block Diagram

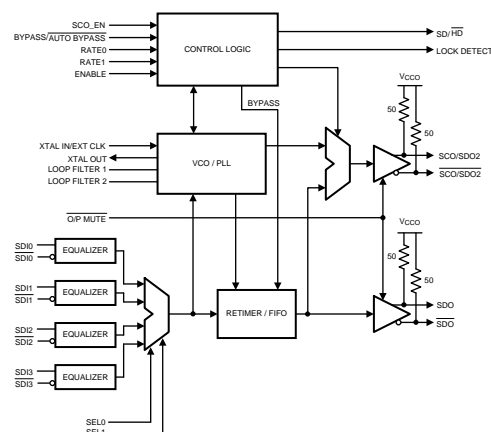

Table of Contents

1 Features 1 2 Applications 1 3 Description 1 4 Revision History 2 5 Description (continued) 3 6 Pin Configuration and Functions 3 7 Specifications 6 7.1 Absolute Maximum Ratings 6 7.2 ESD Ratings..... 6 7.3 Recommended Operating Conditions 6 7.4 Thermal Information 6 7.5 DC Electrical Characteristics 7 7.6 AC Electrical Characteristics..... 8 7.7 AC Timing Requirements 9 8 Detailed Description 10 8.1 Overview 10	8.2 Functional Block Diagram 10 8.3 Feature Description..... 11 8.4 Device Functional Modes 14 9 Application and Implementation 15 9.1 Application Information..... 15 9.2 Typical Application 15 10 Power Supply Recommendations 19 11 Layout 20 11.1 Layout Guidelines 20 11.2 Layout Example 20 12 Device and Documentation Support 21 12.1 Community Resources..... 21 12.2 Trademarks 21 12.3 Electrostatic Discharge Caution..... 21 12.4 Glossary 21 13 Mechanical, Packaging, and Orderable Information 21
---	--

4 Revision History

NOTE: Page numbers for previous revisions may differ from page numbers in the current version.

Changes from Revision K (April 2013) to Revision L	Page
<ul style="list-style-type: none"> • Added <i>ESD Ratings</i> table, <i>Thermal Information</i> table, <i>Feature Description</i> section, <i>Device Functional Modes</i> section, <i>Application and Implementation</i> section, <i>Power Supply Recommendations</i> section, <i>Layout</i> section, <i>Device and Documentation Support</i> section, and <i>Mechanical, Packaging, and Orderable Information</i> section. 	1

5 Description (continued)

The LMH0356 is powered from a single 3.3-V supply. Power dissipation is typically 430 mW. The device is available in two space-saving packages: a 7-mm x 7-mm, 48-pin WQFN and even more space-efficient 5-mm x 5-mm, 40-pin WQFN package.

6 Pin Configuration and Functions

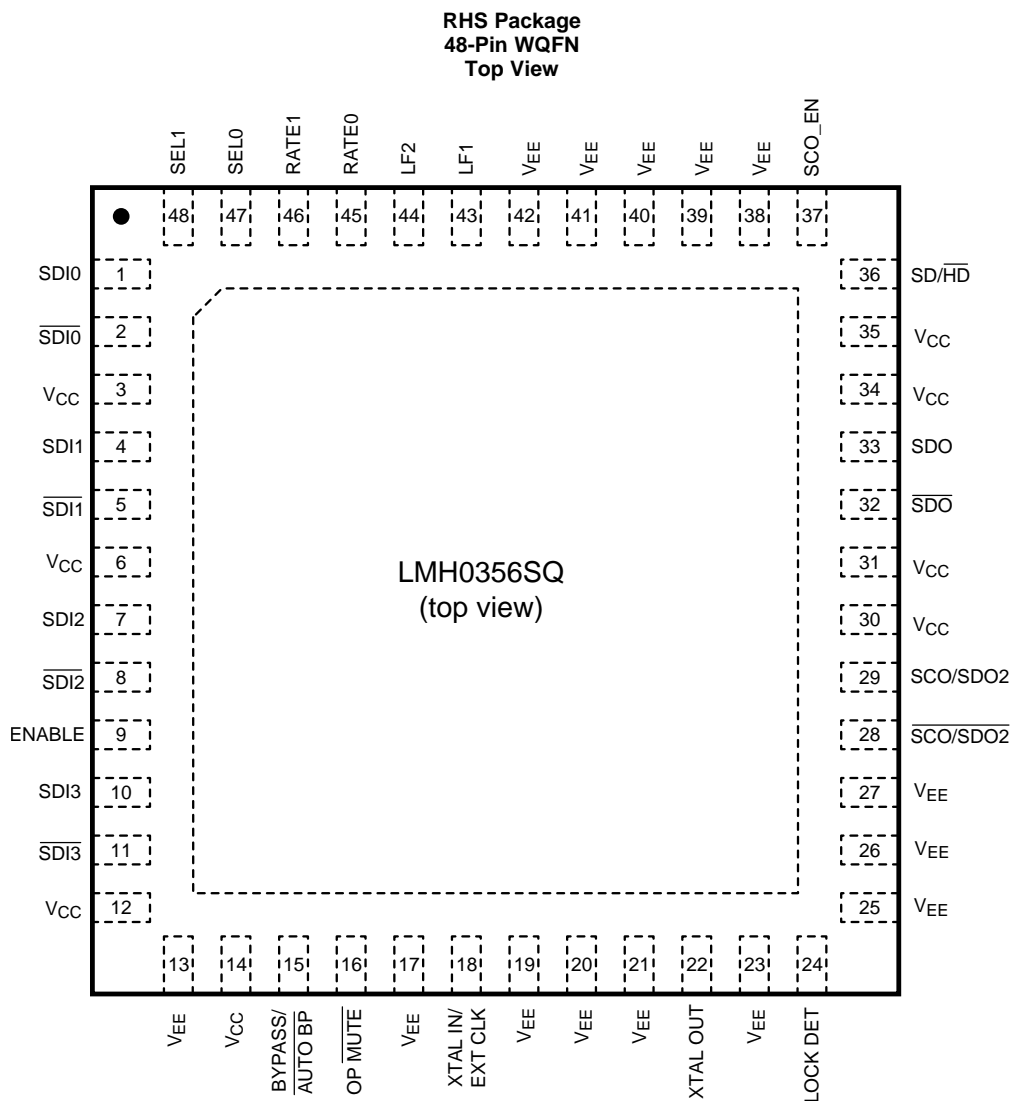

The exposed die attach pad is the primary negative electrical terminal for this device. It must be connected to the negative power supply voltage.

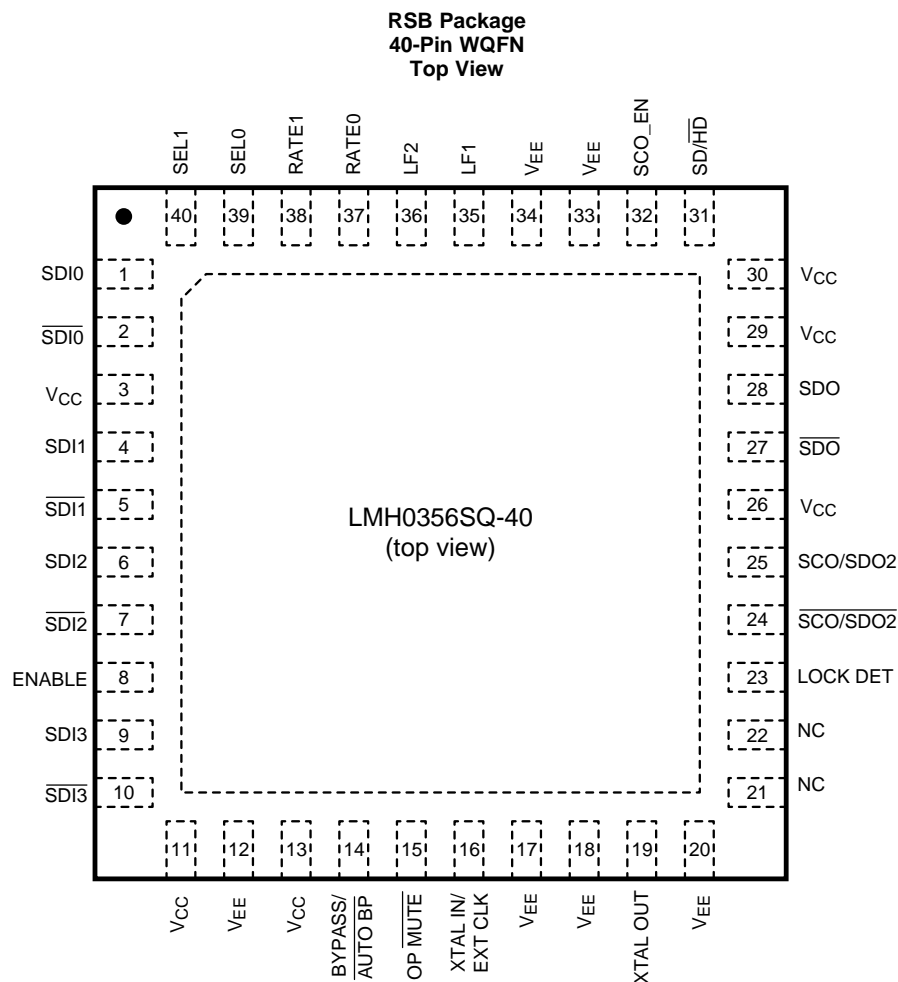

The exposed die attach pad is the primary negative electrical terminal for this device. It must be connected to the negative power supply voltage.

Pin Functions

NAME	PIN		DESCRIPTION
	WQFN 48 PIN	WQFN 40 PIN	
BYPASS/ AUTO BYPASS	15	14	Bypass/Auto Bypass mode select. Bypasses reclocking when high. This pin has an internal pulldown.
ENABLE	9	8	Device Enable. Powers down device when low. This pin has an internal pullup.
LF1	43	35	Loop Filter.
LF2	44	36	Loop Filter.
LOCK DETECT	24	23	PLL Lock Detect output (active high).
OUTPUT MUTE	16	15	Data and Clock Output Mute input. Mutes the output when low. This pin has an internal pullup.
RATE0	45	37	Data Rate select input. This pin has an internal pulldown.
RATE1	46	38	Data Rate select input. This pin has an internal pulldown.
$\overline{\text{SCO/SDO2}}$	28	24	Serial Clock or Serial Data Output 2 Complement.
SCO/SDO2	29	25	Serial Clock or Serial Data Output 2 True.
SCO_EN	37	32	Serial Clock or Serial Data 2 Output select. Sets second output to output the clock when high and the data when low. This pin has an internal pulldown.
$\text{SD}/\overline{\text{HD}}$	36	31	Data Rate Range output. Output is high for SD and low for HD or 3G.

Pin Functions (continued)

NAME	PIN		DESCRIPTION
	WQFN 48 PIN	WQFN 40 PIN	
SDI0	1	1	Data Input 0 True.
$\overline{\text{SDI0}}$	2	2	Data Input 0 Complement.
SDI1	4	4	Data Input 1 True.
$\overline{\text{SDI1}}$	5	5	Data Input 1 Complement.
SDI2	7	6	Data Input 2 True.
$\overline{\text{SDI2}}$	8	7	Data Input 2 Complement.
SDI3	10	9	Data Input 3 True.
$\overline{\text{SDI3}}$	11	10	Data Input 3 Complement.
$\overline{\text{SDO}}$	32	27	Data Output Complement.
SDO	33	28	Data Output True.
SEL0	47	39	Data Input select input. This pin has an internal pulldown.
SEL1	48	40	Data Input select input. This pin has an internal pulldown.
V _{CC}	3, 6, 12, 14, 30, 31, 34, 35,	3, 11, 13, 26, 29, 30	Positive power supply input.
V _{EE}	DAP, 13, 17, 19, 20, 21, 23, 25, 26, 27, 38, 39, 40, 41, 42	12, 17, 18, 20, 33, 34	Negative power supply input.
XTAL IN/EXT CLK	18	16	Crystal or External Oscillator input.
XTAL OUT	22	19	Crystal Oscillator output.
NC	—	21, 22	No connect.

7 Specifications

7.1 Absolute Maximum Ratings

over operating free-air temperature range (unless otherwise noted)⁽¹⁾

		MIN	MAX	UNIT
Supply voltage ($V_{CC} - V_{EE}$)		4		v
Logic supply voltage		$V_{EE} - 0.15$	$V_{CC} + 0.15$	V
Logic input current (single input)	$V_i = V_{EE} - 0.15$ V	-5		mA
	$V_i = V_{CC} + 0.15$ V	5		
Logic output voltage		$V_{EE} - 0.15$	$V_{CC} + 0.15$	V
Logic output source/sink current		-8	8	mA
Serial data output sink current		24		mA
Junction temperature (T_J)		125		°C
Storage temperature (T_{stg})		-65	150	°C

- (1) Stresses beyond those listed under *Absolute Maximum Ratings* may cause permanent damage to the device. These are stress ratings only, which do not imply functional operation of the device at these or any other conditions beyond those indicated under *Recommended Operating Conditions*. Exposure to absolute-maximum-rated conditions for extended periods may affect device reliability.

7.2 ESD Ratings

		VALUE	UNIT
$V_{(ESD)}$ Electrostatic discharge	Human-body model (HBM), per ANSI/ESDA/JEDEC JS-001 ⁽¹⁾	±8000	V
	Charged-device model (CDM), per JEDEC specification JESD22-C101 ⁽²⁾	±1250	
	Machine model (MM)	±400	

- (1) JEDEC document JEP155 states that 500-V HBM allows safe manufacturing with a standard ESD control process. Manufacturing with less than 500-V HBM is possible with the necessary precautions. Pins listed as ±8000 V may actually have higher performance.
- (2) JEDEC document JEP157 states that 250-V CDM allows safe manufacturing with a standard ESD control process. Manufacturing with less than 250-V CDM is possible with the necessary precautions. Pins listed as ±1250 V may actually have higher performance.

7.3 Recommended Operating Conditions

over operating free-air temperature range (unless otherwise noted)

	MIN	NOM	MAX	UNIT
Supply voltage	3.3 – 5%		3.3 + 5%	V
Logic input voltage	V_{EE}		V_{CC}	V
Differential serial input voltage	800 – 10%		800 + 10%	mV
Serial data or clock output sink current			16	mA
Operating free-air temperature	-40		85	°C

7.4 Thermal Information

THERMAL METRIC ⁽¹⁾		LMH0356		UNIT
		RHS (WQFN)	RSB (WQFN)	
		48 PINS	40 PINS	
$R_{\theta JA}$	Junction-to-ambient thermal resistance	28.3	31.2	°C/W
$R_{\theta JC(top)}$	Junction-to-case (top) thermal resistance	8.8	16.8	°C/W
$R_{\theta JC(bot)}$	Junction-to-case (bottom) thermal resistance	1.3	1.2	°C/W

- (1) For more information about traditional and new thermal metrics, see the *Semiconductor and IC Package Thermal Metrics* application report (SPRA953).

7.5 DC Electrical Characteristics

 over supply voltage and recommended operating temperature ranges (unless otherwise noted)⁽¹⁾⁽²⁾

PARAMETER		TEST CONDITIONS	MIN	TYP	MAX	UNIT
V _{IH}	Logic input voltage high level		2		V _{CC}	V
V _{IL}	Logic input voltage low level		V _{EE}		0.8	V
I _{IH}	Logic input current high level	V _{IH} = V _{CC}		47	65	μA
I _{IL}	Logic input current low level	V _{IL} = V _{EE}		-18	-25	μA
V _{OH}	Logic output voltage high level	I _{OH} = -2 mA	2			V
V _{OL}	Logic output voltage low level	I _{OL} = 2 mA			V _{EE} + 0.6	V
V _{SDID}	Serial input voltage, differential	SDI ⁽³⁾	200		1600	mV _{P,P}
V _{CMi}	Input common mode voltage	V _{SDID} = 200 mV ⁽³⁾	V _{EE} + 0.95		V _{CC} - 0.2	V
V _{SDOD}	Serial data output voltage, differential	SDO, SDO2 100-Ω differential load	620	750	880	mV _{P,P}
V _{SCOD}	Serial clock output voltage, differential	SCO 100-Ω differential load, 2970 MHz ⁽³⁾	400	525	650	mV _{P,P}
		SCO 100-Ω differential load, 1485 or 270 MHz		750		mV _{P,P}
V _{CMO}	Output common mode voltage	SDO, SCO 100-Ω differential load		V _{CC} - V _{SDOD}		V
I _{CC}	Power supply current, 3.3-V supply, total	2970 Mbps, device enabled		130	150	mA
		Device disabled (ENABLE = 0)		3		mA

- (1) Current flow into device pins is defined as positive. Current flow out of device pins is defined as negative. All voltages are referenced to V_{EE} (equal to zero volts).
- (2) Typical values are stated for: V_{CC} = 3.3 V, T_A = 25°C.
- (3) This parameter is ensured by characterization over voltage and temperature limits.

7.6 AC Electrical Characteristics

 over supply voltage and recommended operating temperature ranges (unless otherwise noted)⁽¹⁾

PARAMETER		TEST CONDITIONS	MIN	TYP	MAX	UNIT
BR _{SD}	Serial data rate	ST-259		270		Mbps
BR _{SD}	Serial data rate	ST-292		1483, 1485		Mbps
BR _{SD}	Serial data rate	ST-424		2967, 2970		Mbps
TOL _{JIT}	Serial input jitter tolerance	270 Mbps ⁽²⁾⁽³⁾⁽⁴⁾	>6			UI _{P-P}
TOL _{JIT}	Serial input jitter tolerance	270 Mbps ⁽²⁾⁽³⁾⁽⁵⁾	>0.6			UI _{P-P}
TOL _{JIT}	Serial input jitter tolerance	1483 or 1485 Mbps ⁽²⁾⁽³⁾⁽⁴⁾	>6			UI _{P-P}
TOL _{JIT}	Serial input jitter tolerance	1483 or 1485 Mbps ⁽²⁾⁽³⁾⁽⁵⁾	>0.6			UI _{P-P}
TOL _{JIT}	Serial input jitter tolerance	2967 or 2970 Mbps ⁽²⁾⁽³⁾⁽⁴⁾	>6			UI _{P-P}
TOL _{JIT}	Serial input jitter tolerance	2967 or 2970 Mbps ⁽²⁾⁽³⁾⁽⁵⁾	>0.6			UI _{P-P}
t _{JIT}	Serial data output jitter	270 Mbps ⁽³⁾⁽⁶⁾		0.01	0.03	UI _{P-P}
t _{JIT}	Serial data output jitter	1483 or 1485 Mbps ⁽³⁾⁽⁷⁾		0.04	0.05	UI _{P-P}
t _{JIT}	Serial data output jitter	2967 or 2970 Mbps ⁽³⁾⁽⁸⁾		0.08	0.09	UI _{P-P}
BW _{LOOP}	Loop bandwidth	270-Mbps, <0.1-dB Peaking		275		kHz
		1485-Mbps, <0.1-dB Peaking		1.5		MHz
		2970 Mbps, <0.1-dB Peaking		2.75		MHz
F _{CO}	Serial clock output frequency	270-Mbps data rate		270		MHz
F _{CO}	Serial clock output frequency	1483-Mbps data rate		1483		MHz
F _{CO}	Serial clock output frequency	1485-Mbps data rate		1485		MHz
F _{CO}	Serial clock output frequency	2967-Mbps data rate		2967		MHz
F _{CO}	Serial clock output frequency	2970-Mbps data rate		2970		MHz
t _{JIT}	Serial Clock Output Jitter			2	3	ps _{RMS}
SC _{ALG}	Serial clock output alignment with respect to data interval	See ⁽³⁾	40%		60%	
SC _{ODC}	Serial clock output duty cycle	See ⁽³⁾	45%		55%	
F _{REF}	Reference clock frequency			27		MHz
F _{TOL}	Reference clock frequency tolerance			±50		ppm

(1) Typical values are stated for: V_{CC} = 3.3 V, T_A = 25°C.

(2) Peak-to-peak amplitude with sinusoidal modulation per SMPTE RP 184-1996 paragraph 4.1. The test data signal shall be color bars.

(3) This parameter is ensured by characterization over voltage and temperature limits.

(4) Refer to A1 in Figure 1 of SMPTE RP 184-1996.

(5) Refer to A2 in Figure 1 of SMPTE RP 184-1996.

(6) PRBS 2¹⁰-1, input jitter = 31 ps_{P-P}.

(7) PRBS 2¹⁰-1, input jitter = 24 ps_{P-P}.

(8) PRBS 2¹⁰-1, input jitter = 22 ps_{P-P}.

7.7 AC Timing Requirements

			MIN	NOM	MAX	UNIT
T_{ACQ}	Acquisition time	See ⁽¹⁾			15	ms
t_r, t_f	Logic inputs rise/fall time	10%–90%		1.5		ns
t_r, t_f	Input rise/fall time	20%–80%, 270 Mbps ⁽²⁾			1500	ps
t_r, t_f	Input rise/fall time	20%–80%, 1483 or 1485 Mbps ⁽²⁾			270	ps
t_r, t_f	Input rise/fall time	20%–80%, 2967 or 2970 Mbps ⁽²⁾			135	ps
t_r, t_f	Logic outputs rise/fall time	10%–90%		1.5		ns
t_r, t_f	Output rise/fall time	20%–80% ^{(3) (4)}		90	130	ps

- (1) Measured from first SDI transition until Lock Detect output goes high (true).
- (2) This specification is ensured by design.
- (3) $R_L = 100\text{-}\Omega$ differential.
- (4) This parameter is ensured by characterization over voltage and temperature limits.

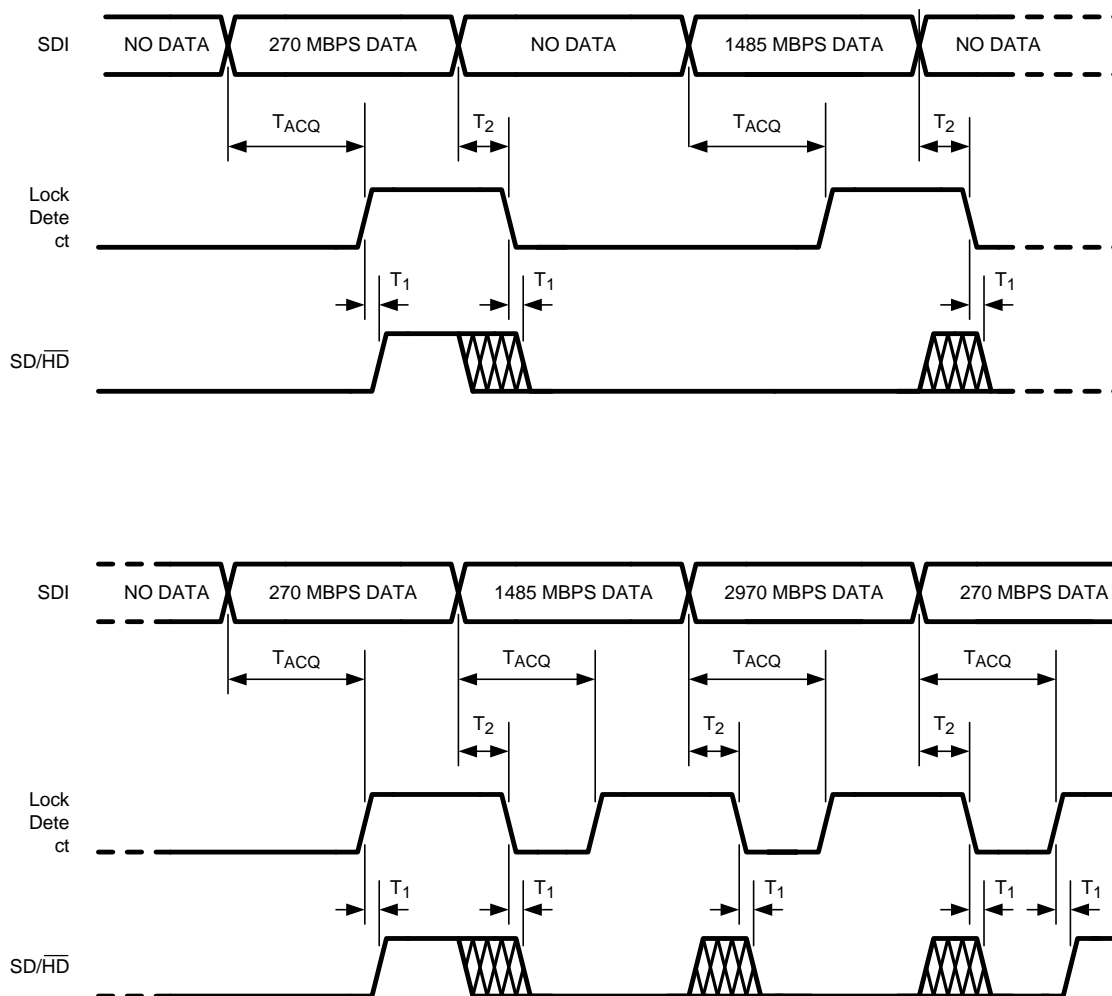

T_{ACQ} = Acquisition Time, defined in [AC Timing Requirements](#)

T_1 = Time from Lock Detect assertion or deassertion until SD/\overline{HD} output is valid, typically 37 ns (one 27-MHz clock period)

T_2 = Time from SDI input change until Lock Detect deassertion, 1 ms maximum. SD/\overline{HD} output is not valid during this time.

Figure 1. SDI, Lock Detect, and SD/\overline{HD} Timing

8 Detailed Description

8.1 Overview

The LMH0356 3-Gbps HD/SD SDI Reclocker with 4:1 Input Mux and FR4 EQs is used in many types of digital video signal processing equipment. Supported serial digital video standards are ST-259, ST-292, and ST-424. Corresponding serial data rates are 270 Mbps, 1.483 Gbps, 1.485 Gbps, 2.967 Gbps, and 2.97 Gbps. DVB-ASI data at 270 Mbps may also be retimed. The LMH0356 retimes the serial data stream to suppress accumulated jitter. It provides two low-jitter, differential, serial data outputs. The second output may be selected to output either serial data or a low-jitter serial data-rate clock. Controls and indicators are: serial clock or second serial data output select, manual rate select input, SD/HD rate output, lock detect output, auto/manual data bypass and output mute.

Serial data inputs are CML and LVPECL compatible. Serial data and clock outputs are differential CML and produce LVPECL compatible levels. The output buffer design can drive AC or DC-coupled, terminated 100- Ω differential loads. The differential output level is 750 mV_{P-P} into 100- Ω AC- or DC-coupled differential loads. Logic inputs and outputs are LVCMOS compatible.

The device package is a 48-pin WQFN or a 40-pin WQFN. Both package options have an exposed die attach pad. The exposed die attach pad is electrically connected to device ground (V_{EE}) and is the primary electrical terminal for the device. This terminal must be connected to the negative power supply or circuit ground.

8.2 Functional Block Diagram

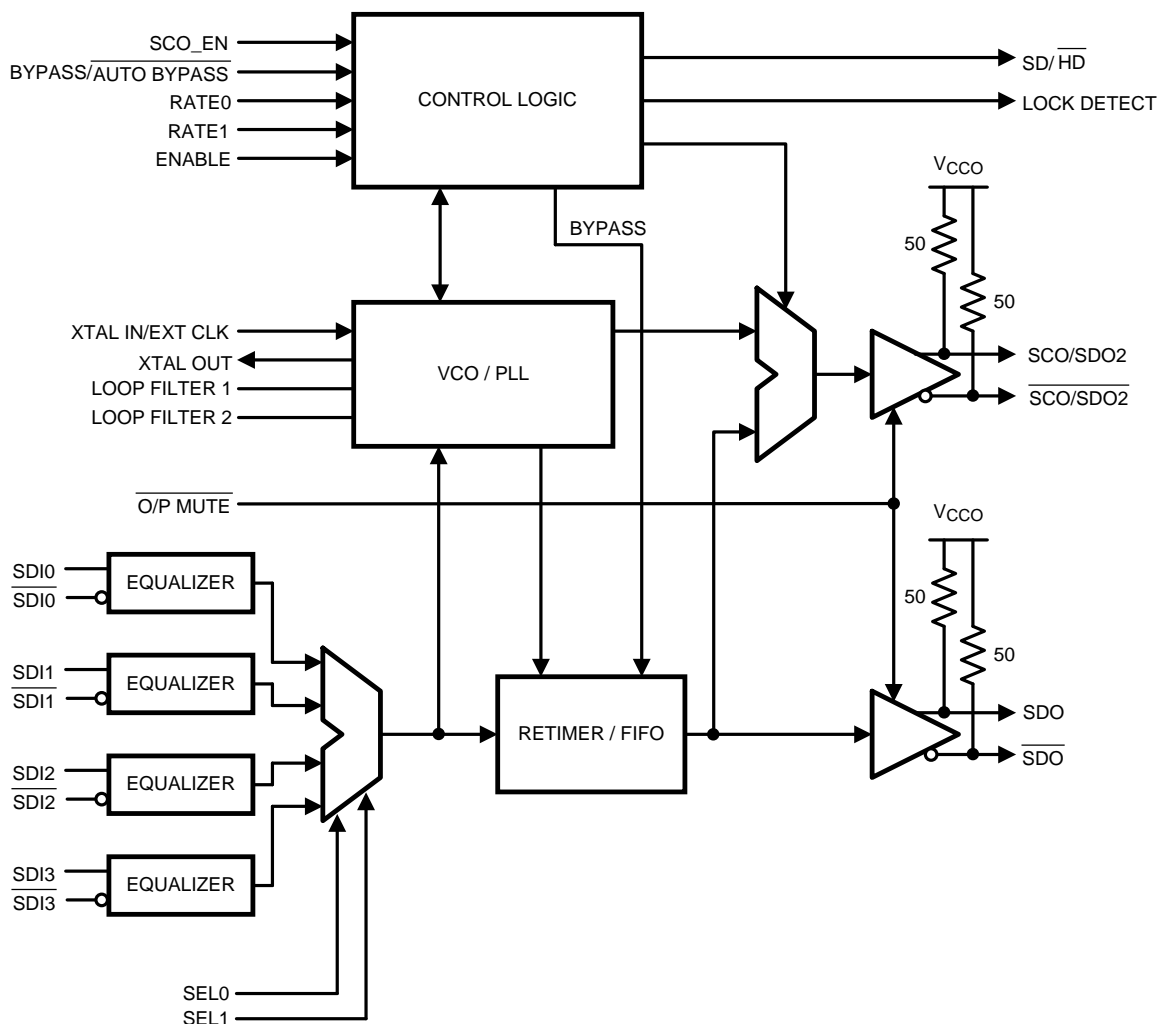

Feature Description (continued)

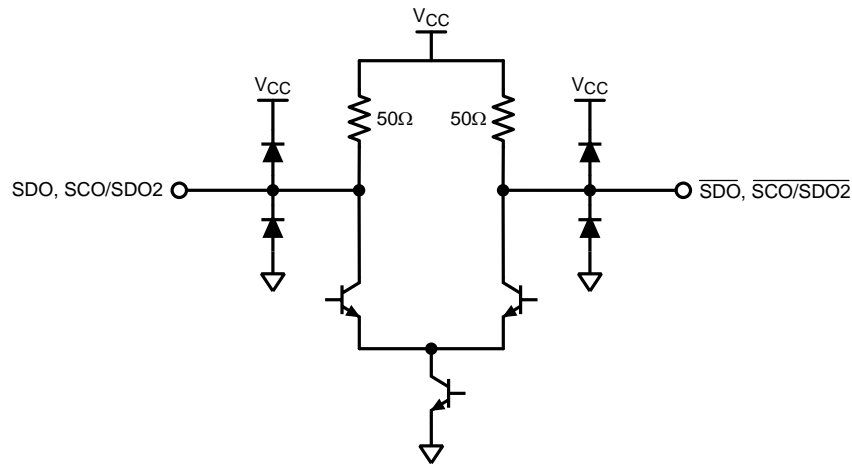

Figure 3. Equivalent SDO Output Circuit (SDO, $\overline{\text{SDO}}$, SCO/SDO2, $\overline{\text{SCO/SDO2}}$)

8.3.1.2 Operating Serial Data Rates

This device operates at serial data rates of 270 Mbps, 1483 Mbps, 1485 Mbps, 2967 Mbps, and 2970 Mbps. The device does not lock to harmonics of these rates. The device does not lock and automatically enters the reclocker bypass mode for the following data rates: 143 Mbps, 177 Mbps, 360 Mbps, and 540 Mbps.

8.3.1.3 Serial Data Clock/Serial Data 2 Output

The Serial Data Clock/Serial Data 2 Output is controlled by the SCO_EN input and provides either a second retimed serial data output or a low jitter differential clock output appropriate to the serial data rate being processed. When operating as a serial clock output, the rising edge of the clock is positioned within the corresponding serial data bit interval within 10% of the center of the data interval.

Differential output SCO/SDO2 functions as the second serial data output when the SCO_EN input is a logic-low level. This output functions as the serial clock output when the SCO_EN input is a logic-high level. The SCO_EN input has an internal pulldown device and the default state of SCO_EN is low (serial data output 2 enabled). SCO/SDO2 is muted when the OUTPUT MUTE input is a logic low level. When the Bypass mode is activated and this output is functioning as a serial clock output, the output is muted. If an unsupported data rate is used while in Auto Bypass mode with this output functioning as a serial clock output, the output is invalid.

8.3.2 Control Inputs and Indicator Outputs

8.3.2.1 Serial Data Rate Selector

The Serial Data Rate Selector (RATE [1:0]) permits the user to fix the operating serial data rate. RATE[1:0] pins have internal pull-downs which maintain a logic-low input condition unless externally driven to a logic-high condition. This input also serves to place the device in a test mode. The codes shown in [Table 1](#) select the desired operating serial data rate. The LMH0356 then enters either the Auto-Rate Detect mode or a single operating rate. Selecting the 270-Mbps rate mode may also be used when reclocking DVB-ASI data. DVB-ASI data is MPEG2 coded data that is transmitted in 8B10B coding. The device reclocks this data without harmonic locking.

Table 1. Data Rate Select Input Codes

RATE [1:0] CODE	DATA RATE OR MODE	COMMENTS
00	Auto-Rate Detect mode	
01	270 Mbps	May be used to support DVB-ASI operation
10	1483/1485 Mbps, 2967/2970 Mbps	

8.3.2.2 Serial Data Input Selector

The Serial Data Input Selector (SEL [1:0]) allows the user to select the active input channel. [Table 2](#) shows the input selected for a given state of SEL [1:0]. The SEL pins have internal pulldowns.

Table 2. Data Input Select Codes

SEL [1:0] CODE	SELECTED INPUT
00	SDI0
01	SDI1
10	SDI2
11	SDI3

8.3.2.3 Lock Detect

The Lock Detect output, when high, indicates that data is being received and the PLL is locked. Lock Detect may be connected to the OUTPUT MUTE input to mute the data and clock outputs when no data signal is being received. Note that when the Bypass/Auto Bypass input is set high, Lock Detect will remain low. See [Table 3](#).

8.3.2.4 OUTPUT MUTE

The OUTPUT MUTE input, when low, mutes the serial data and clock outputs. It may be connected to Lock Detect or externally driven to mute or un-mute the outputs. If OUTPUT MUTE is connected to Lock Detect, then the data and clock outputs are muted when the PLL is not locked. This function overrides the Bypass function; see [Table 3](#). OUTPUT MUTE has an internal pullup device to enable the output by default.

8.3.2.5 Bypass/AUTO BYPASS

The Bypass/Auto Bypass input, when high, forces the device to output the data without reclocking it. When this input is low, the device automatically bypasses the reclocking function when the device is in an unlocked condition or the detected data rate is a rate which the device does not support. Note that when the Bypass/Auto Bypass input is set high, Lock Detect remains low. See [Table 3](#). BYPASS/AUTO BYPASS has an internal pulldown device.

Table 3. Control Functionality

LOCK DETECT	OUTPUT MUTE	BYPASS/AUTO BYPASS	DEVICE STATUS
0	1	X	PLL unlocked, reclocker bypassed
1	1	0	PLL locked to supported data rate, reclocker not bypassed
X	0	X	Outputs muted
0	LOCK DETECT	X	Outputs muted
1	LOCK DETECT	0	PLL locked to supported data rate, reclocker not bypassed

8.3.2.6 SD/HD

The SD/HD output indicates whether the LMH0356 is processing SD or HD / 3 Gbps data rates. It may be used to control another device such as the LMH0302 cable driver. When this output is high it indicates that the data rate is 270 Mbps. When low, the indicated data rate is 1483, 1485, 2967, or 2970 Mbps. The SD/HD output is a registered function and is only valid when the PLL is locked and the Lock Detect output is high. When the PLL is not locked (the Lock Detect output is low), the SD/HD output defaults to HD (low). The SD/HD output is undefined for a short time after lock detect assertion or de-assertion due to a data rate change on SDI. See [Figure 1](#) for a timing diagram showing the relationship between SDI, Lock Detect, and SD/HD.

8.3.2.7 SCO_EN

Input SCO_EN enables the SCO/SDO2 differential output to function either as a serial clock or second serial data output. SCO/SDO2 functions as a serial clock when SCO_EN is high. This pin has an internal pulldown device. The default state (low) enables the SCO/SDO2 output as a second serial data output.

8.3.2.8 ENABLE

The ENABLE pin is used to enable or disable the LMH0356. When the device is disabled, the output drivers and most of the internal circuitry are powered down. The crystal oscillator and external clock reference circuitry (XTAL IN and XTAL OUT) remain active regardless of the state of ENABLE, allowing the 27-MHz reference clock signal to be generated and passed on to additional reclockers. The ENABLE pin is active high and has an internal pullup device to enable the LMH0356 by default.

8.3.2.9 Crystal or External Clock Reference

The LMH0356 uses a 27-MHz crystal or external clock signal as a timing reference input. A 27-MHz parallel resonant crystal and load network may be connected to the XTAL IN/EXT CLK and XTAL OUT pins. Alternatively, a 27-MHz LVCMOS compatible clock signal may be input to XTAL IN/EXT CLK. Parameters for a suitable crystal are given in [Table 4](#).

Table 4. Crystal Parameters

PARAMETER	VALUE
Frequency	27 MHz
Frequency stability	±50 ppm at recommended drive level
Operating mode	Fundamental mode, parallel resonant
Load capacitance	20 pF
Shunt capacitance	7 pF
Series resistance	40 Ω (maximum)
Recommended drive level	100 μW
Maximum drive level	500 μW
Operating temperature	–10°C to 60°C

8.4 Device Functional Modes

The LMH0356 features are programmed using pin control. Refer to [Control Inputs and Indicator Outputs](#) for details.

9 Application and Implementation

NOTE

Information in the following applications sections is not part of the TI component specification, and TI does not warrant its accuracy or completeness. TI's customers are responsible for determining suitability of components for their purposes. Customers should validate and test their design implementation to confirm system functionality.

9.1 Application Information

The LMH0356 3-Gbps HD/SD SDI Reclocker with 4:1 Input Mux and FR4 EQs is used in many types of digital video signal processing equipment.

9.2 Typical Application

Figure 4 and Figure 5 show typical system and application circuits for the 48-pin WQFN version of the LMH0356.

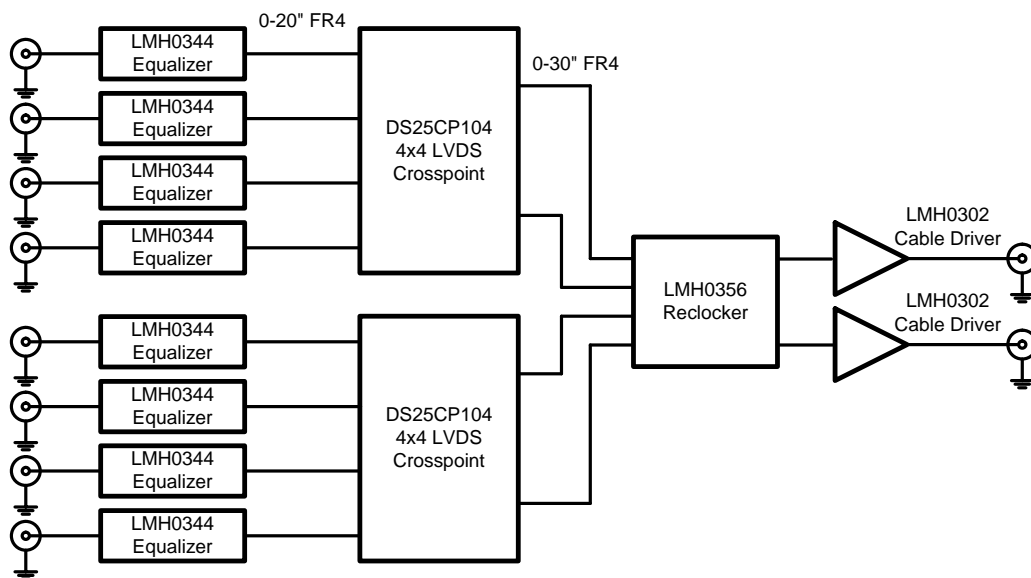
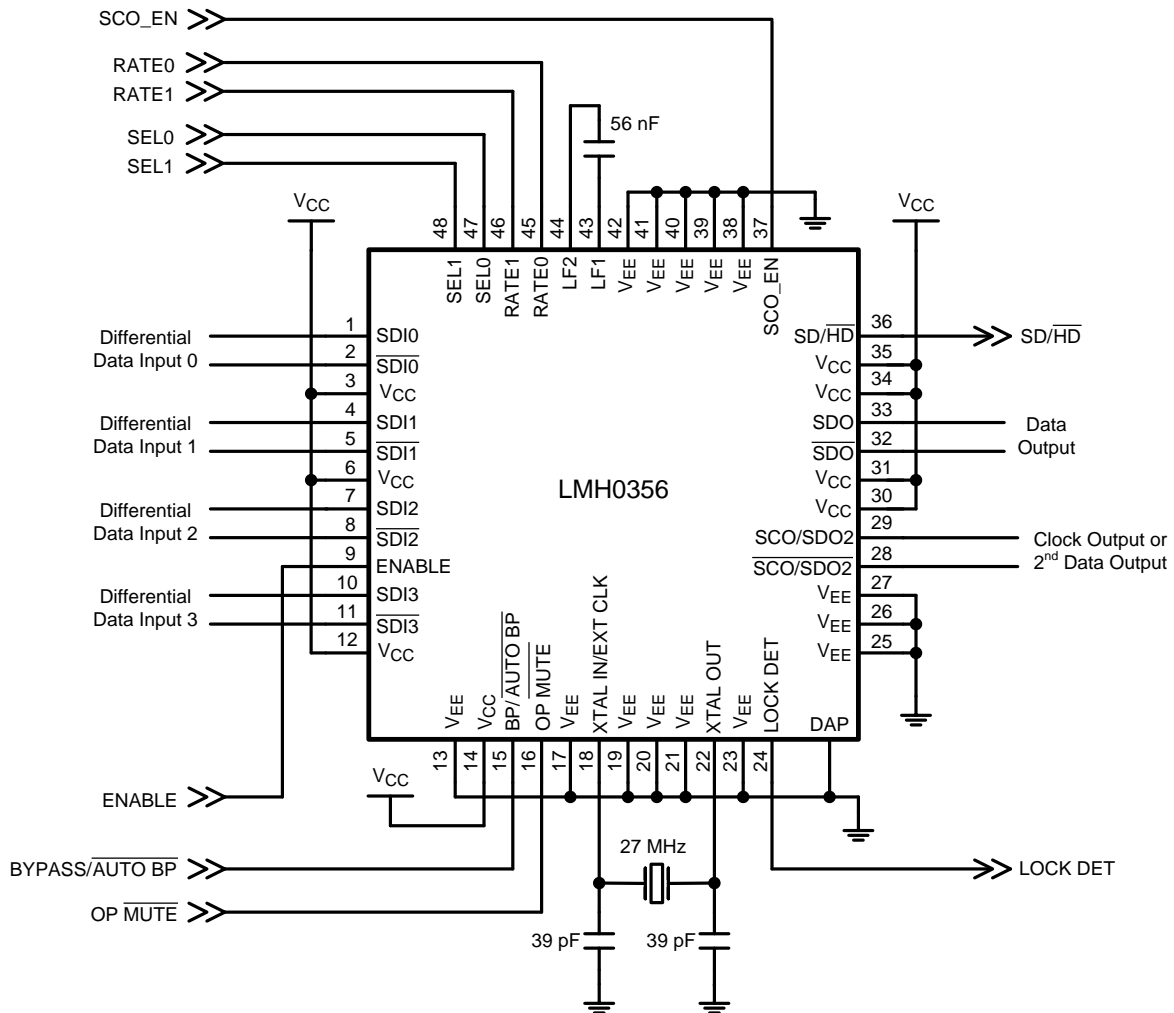

Figure 4. System Block Diagram

Typical Application (continued)

Figure 5. Application Circuit

ENABLE has an internal pullup to enable the device by default. This pin may be pulled low to put the LMH0356 into a powered down mode.

BP/AUTO BP has an internal pulldown to enable Auto Bypass mode by default. This pin may be pulled high to force the LMH0356 to bypass all data.

OP $\overline{\text{MUTE}}$ has an internal pullup to enable the outputs by default. This pin may be pulled low to mute the outputs.

The XTAL IN/EXT CLK and XTAL OUT pins are shown with a 27-MHz crystal and the proper loading. The crystal should match the parameters described in [Table 4](#). Alternately, a 27-MHz LVCMOS compatible clock signal may be input to XTAL IN/EXT CLK.

The active high LOCK DET output provides an indication that proper data is being received and the PLL is locked.

The SD/HD output may be used to drive the SD/HD pin of an SDI cable driver (such as the LMH0302) in order to properly set the cable driver's edge rate for SMPTE compliance. It defaults to HD/3G (low) when the LMH0356 is not locked.

Typical Application (continued)

SCO_EN has an internal pulldown to set the second output (SCO/SDO2) to output data. This pin may be pulled high to set the second output as a serial clock.

The external loop filter capacitor (between LF1 and LF2) must be 56 nF. This is the only supported value; the loop filter capacitor must not be changed.

RATE0 and RATE1 have internal pulldowns to select Auto-Rate Detect mode by default. These pins may also be used to set the device to SD mode or HD/3G mode.

SEL0 and SEL1 have internal pulldowns to select the SDI0 input by default.

9.2.1 Design Requirements

For this design example, use the parameters listed in [Table 5](#) as the input parameters.

Table 5. LMH0356 Design Parameters

DESIGN PARAMETER	REQUIREMENTS
Input AC-coupling capacitors	The user should check output common mode voltage of the device attached to SDI pins. If AC-coupling capacitor is required, AC-coupling capacitor is expected to be 4.7 μ F \pm 10%. Refer to Input Output Interfacing for details.
Output AC-coupling capacitors	The user should check input common mode voltage of the device attached to SDO pins. If AC-coupling capacitor is required, AC-coupling capacitor is expected to be 4.7 μ F \pm 10%. Refer to Input Output Interfacing for details.
DC power supply coupling capacitors	De-coupling capacitors are required to minimize power supply ripple noise. Place 4.7- μ F and 0.1- μ F surface mount ceramic capacitors as close to the device V _{CC} pin as possible .
High-speed SDI and SDO trace impedance	SDI \pm and SDO \pm must be routed with coupled board traces with 100- Ω \pm 5% differential impedance.
Use of ENABLE, RATE0/1, SCO_EN, OP $\overline{\text{MUTE}}$, and BP/AUTO BP pins	Set these pins for desired operating mode.
LOCK DET pin	Use this pin for lock indication or to OP $\overline{\text{MUTE}}$ pin to enable output when locked.
SD/ $\overline{\text{HD}}$ Pin	Use SD/ $\overline{\text{HD}}$ to set cable driver edge rate or to FPGA for lock rate monitoring.

9.2.2 Detailed Design Procedure

To begin the design process, determine the following:

1. Check that the power supply meets the DC and AC requirements in [DC Electrical Characteristics](#).
2. Select the proper pull-high or pull-low resistors for ENABLE, RATE0/1, SCO_EN, OP $\overline{\text{MUTE}}$, and BP/AUTO BP pins.
3. Use SD/ $\overline{\text{HD}}$ output signal to set the cable driver edge rate.
4. Refer to [Input Output Interfacing](#) for Input or Output DC- or AC-coupling.
5. Choose small 0402 surface mount ceramic capacitors for AC-coupling and bypass capacitors.
6. Pay close attention to high speed printed circuit board layout for the high speed SDI \pm and SDO \pm signals.
7. Plan out overall system jitter budget with [AC Electrical Characteristics](#) in mind.

9.2.2.1 Input Output Interfacing

The inputs are LVPECL compatible. The LMH0356 has a wide input common mode range, and in most cases the input should be DC-coupled. For DC-coupling, the inputs must be kept within the common mode range specified in [DC Electrical Characteristics](#).

[Figure 6](#) shows an example of a DC-coupled interface between the LMH0344 cable equalizer and the LMH0356. The LMH0344 output common mode voltage and voltage swing are within the range of the input common mode voltage and voltage swing of the LMH0356. In this figure, the LMH0344 cable equalizer restores the signal after the coaxial cable. The LMH0356 FR4 equalizer restores the signal after the loss due to the FR4 trace. The LMH0356 inputs have 50- Ω internal terminations (100- Ω differential) to terminate the transmission line, so no additional components are required.

LMH0356

SNLS270L – AUGUST 2007 – REVISED JANUARY 2016

www.ti.com

The outputs are LVPECL compatible. SDO is the primary data output and SCO/SDO2 is a second output that may be set as the serial clock or a second data output. Both outputs are always active. The LMH0356 output should be DC-coupled to the input of the receiving device as long as the common mode ranges of both devices are compatible.

Figure 7 shows an example of a DC-coupled interface between the LMH0356 and LMH0302 cable driver. All that is required is a 100-Ω differential termination as shown. The resistor should be placed as close to the LMH0302 input as possible. If desired, this network may be terminated with two 50-Ω resistors and a center tap capacitor to ground in place of the single 100-Ω resistor.

The LMH0356 has multiple ground connections, however; the primary ground connection is through the large exposed DAP. The DAP must be connected to ground for proper operation of the LMH0356.

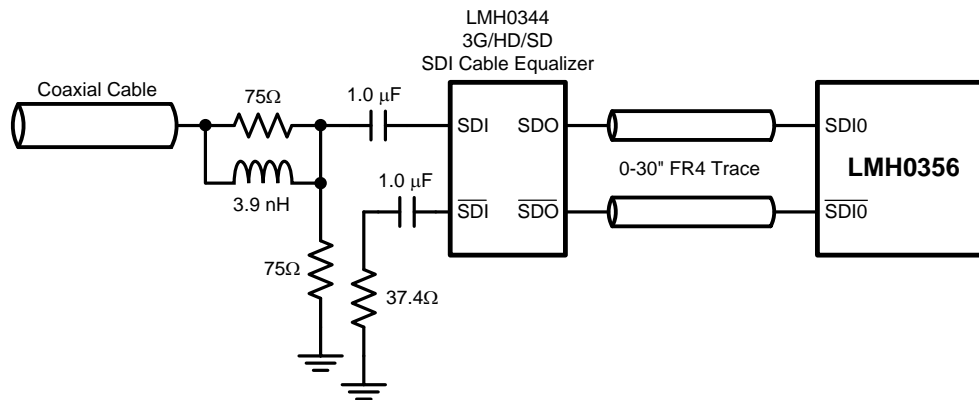
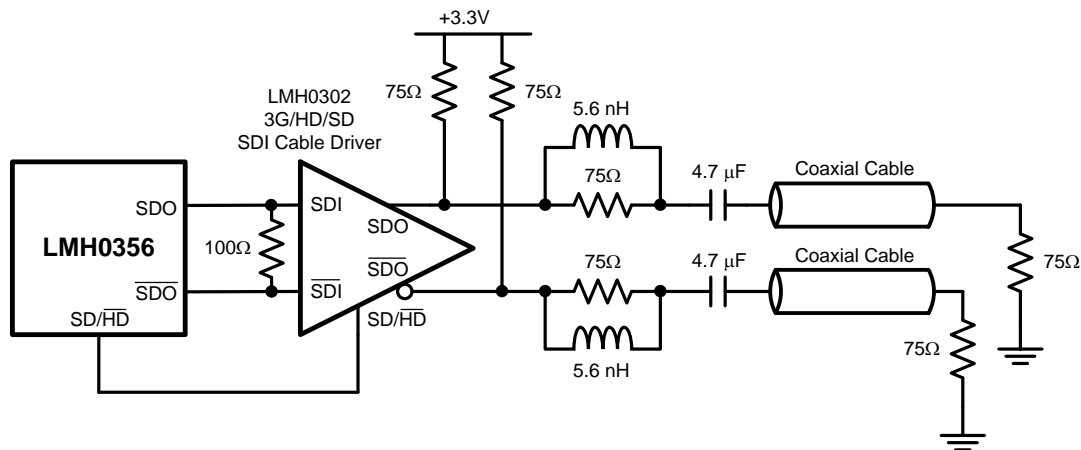
Figure 6. DC Input Interface

Figure 7. DC Output Interface

9.2.3 Application Curves

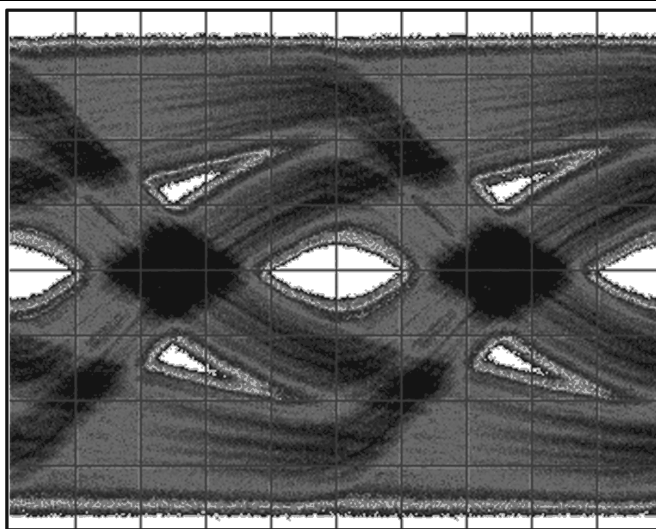

Figure 8. 2.97-Gbps Signal Before FR4 Equalization
(0.6-UI Jitter)

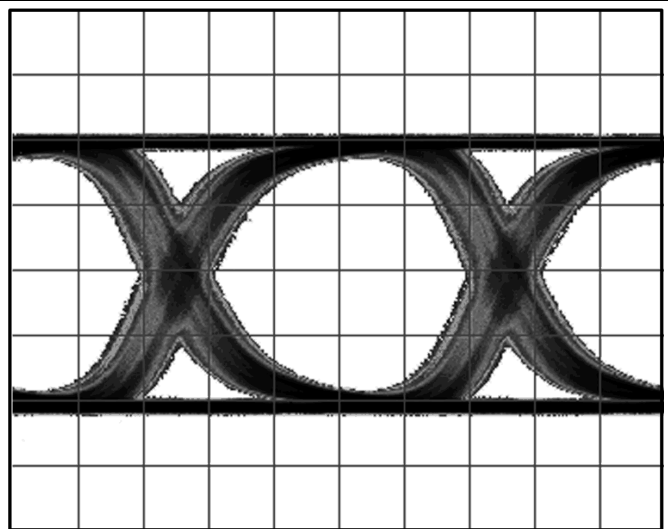

Figure 9. 2.97-Gbps Signal After FR4 Equalization
(0.23-UI Jitter)

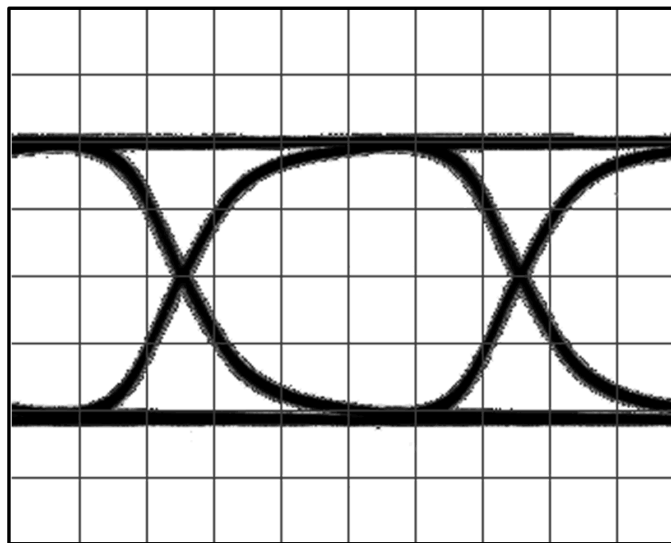

Figure 10. 2.97-Gbps Signal After Reclocking
(0.06-UI Jitter)

10 Power Supply Recommendations

Follow these general guidelines when designing the power supply:

1. The power supply must be designed to provide the recommended operating conditions in terms of DC voltage.
2. The maximum current consumption for the LMH0356 is provided in the data sheet. This figure can be used to calculate the maximum current the supply must provide.
3. Place 4.7- μ F bulk capacitor and 0.1- μ F de-coupling capacitors as close to LMH0356 V_{CC} pins as possible.

11 Layout

11.1 Layout Guidelines

Figure 11 shows a typical PCB layout for the 48-pin WQFN version of the LMH0356. The following guidelines are recommended for designing the board layout for the LMH0356:

1. Choose a suitable board stack-up such that it supports 100-Ω differential trace routing on board layer 1. This is typically done with layer 2 ground plane reference for the 100-Ω differential traces.
2. Place 56-nF loop filter capacitor as close to the loop filter pins as possible.
3. Use coupled differential traces with 100-Ω ± 5% impedance for signal routing to SDI± and SDO± pins. These are usually 5 to 8-mil trace width reference to a ground plane at layer 2.
4. DAP of the package must be connected to the ground plane through an array of via. These nine vias are solder-masked to avoid solder flowing into the plated-through holes during the board manufacturing process. DAP is divided into 16 squares (1.09 mm × 1.09 mm) inside 5.1-mm × 5.1-mm landing pad.
5. Connect supply pins V_{CC} and V_{EE} to the power and ground planes with short via. The via is usually placed tangent to the supply pin landing pad with the shortest trace possible.
6. Power supply bypass capacitors must be placed close to the supply pin. They are commonly placed at the bottom layer sharing the ground connector of the DAP.

11.2 Layout Example

Figure 11 shows a typical PCB layout for the 48-pin WQFN version of the LMH0356.

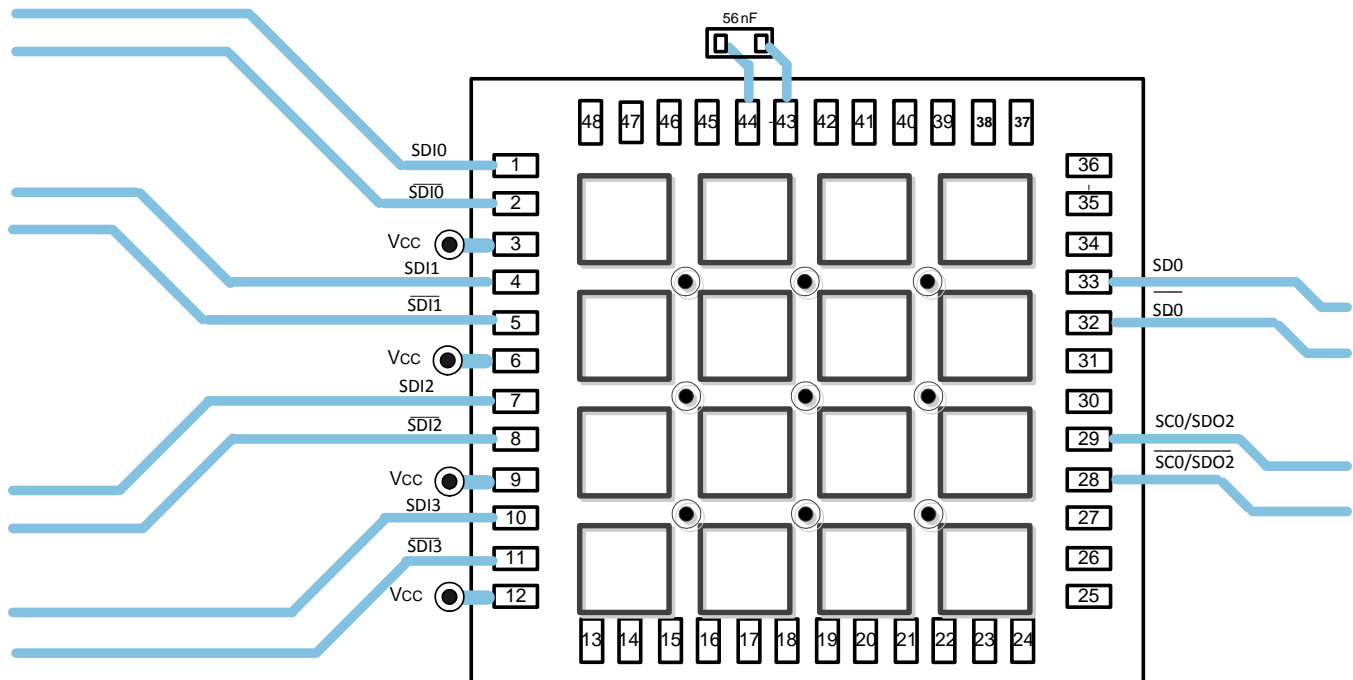

Figure 11. LMH0356 PCB Layout Example

12 Device and Documentation Support

12.1 Community Resources

The following links connect to TI community resources. Linked contents are provided "AS IS" by the respective contributors. They do not constitute TI specifications and do not necessarily reflect TI's views; see TI's [Terms of Use](#).

TI E2E™ Online Community *TI's Engineer-to-Engineer (E2E) Community*. Created to foster collaboration among engineers. At e2e.ti.com, you can ask questions, share knowledge, explore ideas and help solve problems with fellow engineers.

Design Support *TI's Design Support* Quickly find helpful E2E forums along with design support tools and contact information for technical support.

12.2 Trademarks

E2E is a trademark of Texas Instruments.
All other trademarks are the property of their respective owners.

12.3 Electrostatic Discharge Caution



These devices have limited built-in ESD protection. The leads should be shorted together or the device placed in conductive foam during storage or handling to prevent electrostatic damage to the MOS gates.

12.4 Glossary

[SLYZ022](#) — *TI Glossary*.

This glossary lists and explains terms, acronyms, and definitions.

13 Mechanical, Packaging, and Orderable Information

The following pages include mechanical, packaging, and orderable information. This information is the most current data available for the designated devices. This data is subject to change without notice and revision of this document. For browser-based versions of this data sheet, refer to the left-hand navigation.

PACKAGING INFORMATION

Orderable Device	Status (1)	Package Type	Package Drawing	Pins	Package Qty	Eco Plan (2)	Lead/Ball Finish (6)	MSL Peak Temp (3)	Op Temp (°C)	Device Marking (4/5)	Samples
LMH0356SQ-40/NOPB	ACTIVE	WQFN	RSB	40	1000	Green (RoHS & no Sb/Br)	CU SN	Level-1-260C-UNLIM	-40 to 85	L0356	Samples
LMH0356SQ/NOPB	ACTIVE	WQFN	RHS	48	1000	Green (RoHS & no Sb/Br)	CU SN	Level-3-260C-168 HR	-40 to 85	L0356	Samples
LMH0356SQE-40/NOPB	ACTIVE	WQFN	RSB	40	250	Green (RoHS & no Sb/Br)	CU SN	Level-1-260C-UNLIM	-40 to 85	L0356	Samples
LMH0356SQE/NOPB	ACTIVE	WQFN	RHS	48	250	Green (RoHS & no Sb/Br)	CU SN	Level-3-260C-168 HR	-40 to 85	L0356	Samples

(1) The marketing status values are defined as follows:

ACTIVE: Product device recommended for new designs.

LIFEBUY: TI has announced that the device will be discontinued, and a lifetime-buy period is in effect.

NRND: Not recommended for new designs. Device is in production to support existing customers, but TI does not recommend using this part in a new design.

PREVIEW: Device has been announced but is not in production. Samples may or may not be available.

OBSOLETE: TI has discontinued the production of the device.

(2) **RoHS:** TI defines "RoHS" to mean semiconductor products that are compliant with the current EU RoHS requirements for all 10 RoHS substances, including the requirement that RoHS substance do not exceed 0.1% by weight in homogeneous materials. Where designed to be soldered at high temperatures, "RoHS" products are suitable for use in specified lead-free processes. TI may reference these types of products as "Pb-Free".

RoHS Exempt: TI defines "RoHS Exempt" to mean products that contain lead but are compliant with EU RoHS pursuant to a specific EU RoHS exemption.

Green: TI defines "Green" to mean the content of Chlorine (Cl) and Bromine (Br) based flame retardants meet JS709B low halogen requirements of <=1000ppm threshold. Antimony trioxide based flame retardants must also meet the <=1000ppm threshold requirement.

(3) MSL, Peak Temp. - The Moisture Sensitivity Level rating according to the JEDEC industry standard classifications, and peak solder temperature.

(4) There may be additional marking, which relates to the logo, the lot trace code information, or the environmental category on the device.

(5) Multiple Device Markings will be inside parentheses. Only one Device Marking contained in parentheses and separated by a "-" will appear on a device. If a line is indented then it is a continuation of the previous line and the two combined represent the entire Device Marking for that device.

(6) Lead/Ball Finish - Orderable Devices may have multiple material finish options. Finish options are separated by a vertical ruled line. Lead/Ball Finish values may wrap to two lines if the finish value exceeds the maximum column width.

Important Information and Disclaimer: The information provided on this page represents TI's knowledge and belief as of the date that it is provided. TI bases its knowledge and belief on information provided by third parties, and makes no representation or warranty as to the accuracy of such information. Efforts are underway to better integrate information from third parties. TI has taken and

continues to take reasonable steps to provide representative and accurate information but may not have conducted destructive testing or chemical analysis on incoming materials and chemicals. TI and TI suppliers consider certain information to be proprietary, and thus CAS numbers and other limited information may not be available for release.

In no event shall TI's liability arising out of such information exceed the total purchase price of the TI part(s) at issue in this document sold by TI to Customer on an annual basis.

TAPE AND REEL INFORMATION

QUADRANT ASSIGNMENTS FOR PIN 1 ORIENTATION IN TAPE



*All dimensions are nominal

Device	Package Type	Package Drawing	Pins	SPQ	Reel Diameter (mm)	Reel Width W1 (mm)	A0 (mm)	B0 (mm)	K0 (mm)	P1 (mm)	W (mm)	Pin1 Quadrant
LMH0356SQ-40/NOPB	WQFN	RSB	40	1000	178.0	12.4	5.3	5.3	1.3	8.0	12.0	Q1
LMH0356SQ/NOPB	WQFN	RHS	48	1000	330.0	16.4	7.3	7.3	1.3	12.0	16.0	Q1
LMH0356SQE-40/NOPB	WQFN	RSB	40	250	178.0	12.4	5.3	5.3	1.3	8.0	12.0	Q1
LMH0356SQE/NOPB	WQFN	RHS	48	250	178.0	16.4	7.3	7.3	1.3	12.0	16.0	Q1

TAPE AND REEL BOX DIMENSIONS

*All dimensions are nominal

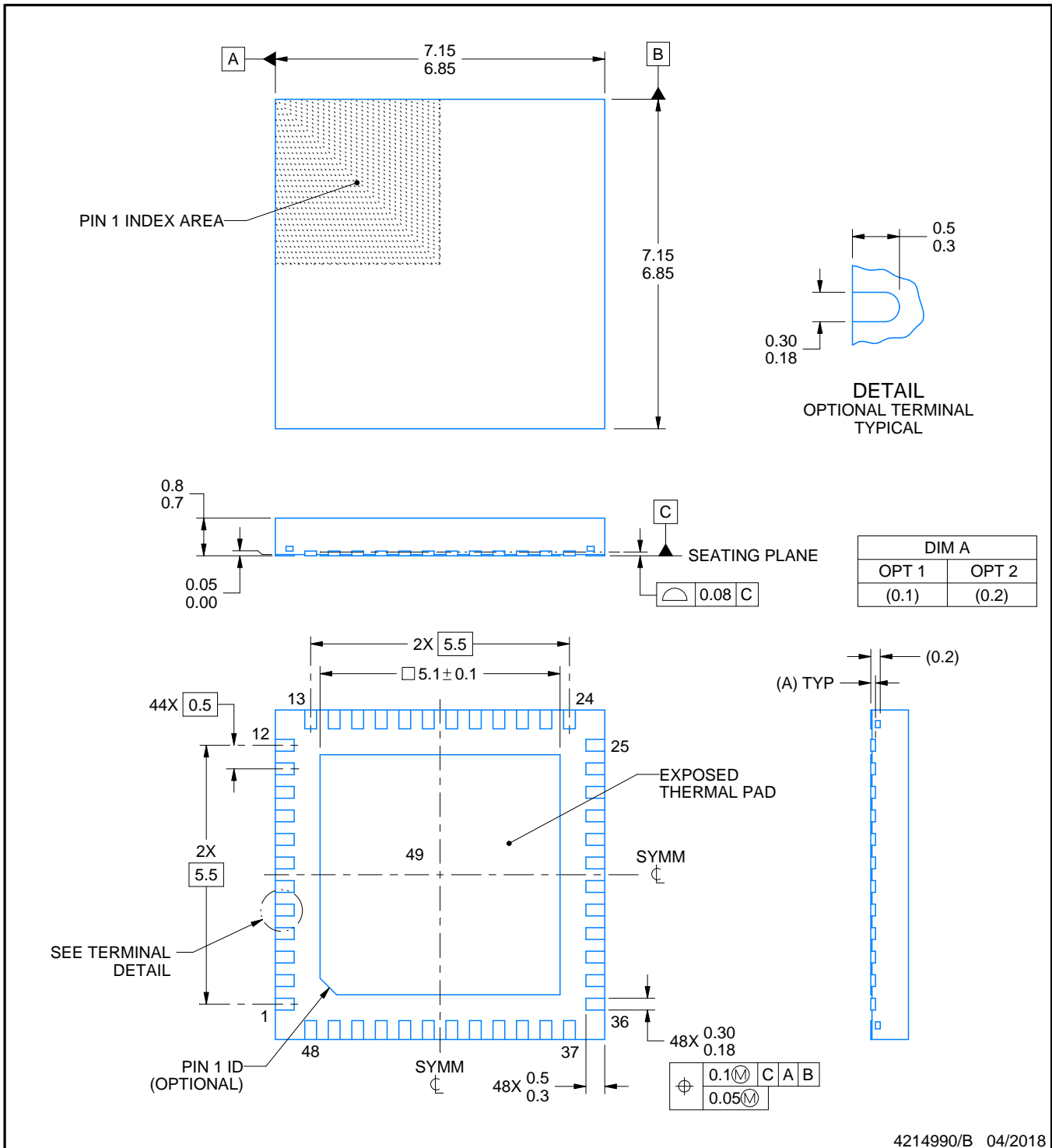
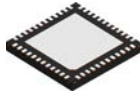
Device	Package Type	Package Drawing	Pins	SPQ	Length (mm)	Width (mm)	Height (mm)
LMH0356SQ-40/NOPB	WQFN	RSB	40	1000	210.0	185.0	35.0
LMH0356SQ/NOPB	WQFN	RHS	48	1000	367.0	367.0	38.0
LMH0356SQE-40/NOPB	WQFN	RSB	40	250	210.0	185.0	35.0
LMH0356SQE/NOPB	WQFN	RHS	48	250	210.0	185.0	35.0



4214990/B 04/2018

NOTES:

1. All linear dimensions are in millimeters. Any dimensions in parenthesis are for reference only. Dimensioning and tolerancing per ASME Y14.5M.
2. This drawing is subject to change without notice.
3. The package thermal pad must be soldered to the printed circuit board for thermal and mechanical performance.

EXAMPLE BOARD LAYOUT

RHS0048A

WQFN - 0.8 mm max height

PLASTIC QUAD FLATPACK - NO LEAD

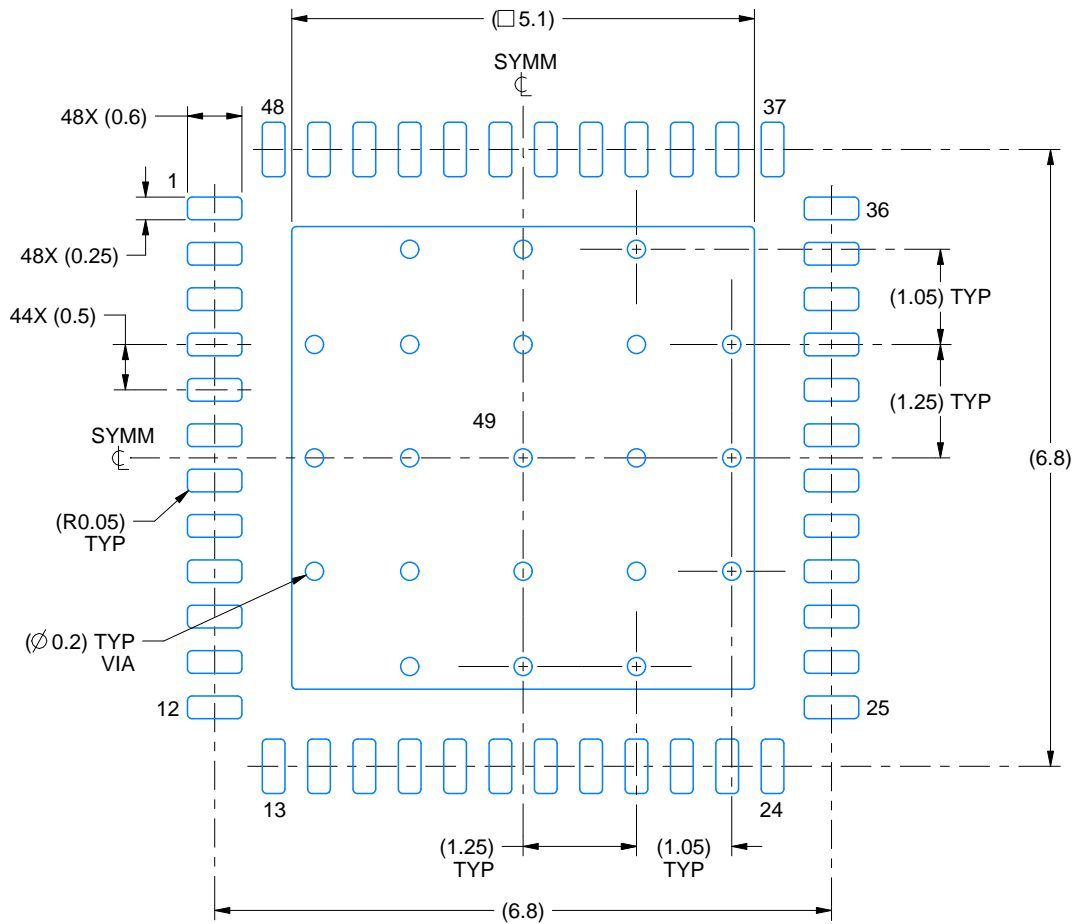

LAND PATTERN EXAMPLE
EXPOSED METAL SHOWN
SCALE:12X

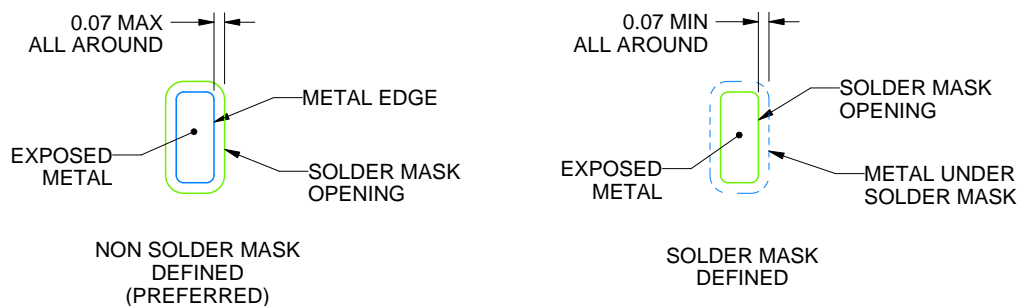

SOLDER MASK DETAILS

4214990/B 04/2018

NOTES: (continued)

4. This package is designed to be soldered to a thermal pad on the board. For more information, see Texas Instruments literature number SLUA271 (www.ti.com/lit/slua271).
5. Vias are optional depending on application, refer to device data sheet. If any vias are implemented, refer to their locations shown on this view. It is recommended that vias under paste be filled, plugged or tented.

EXAMPLE STENCIL DESIGN

RHS0048A

WQFN - 0.8 mm max height

PLASTIC QUAD FLATPACK - NO LEAD

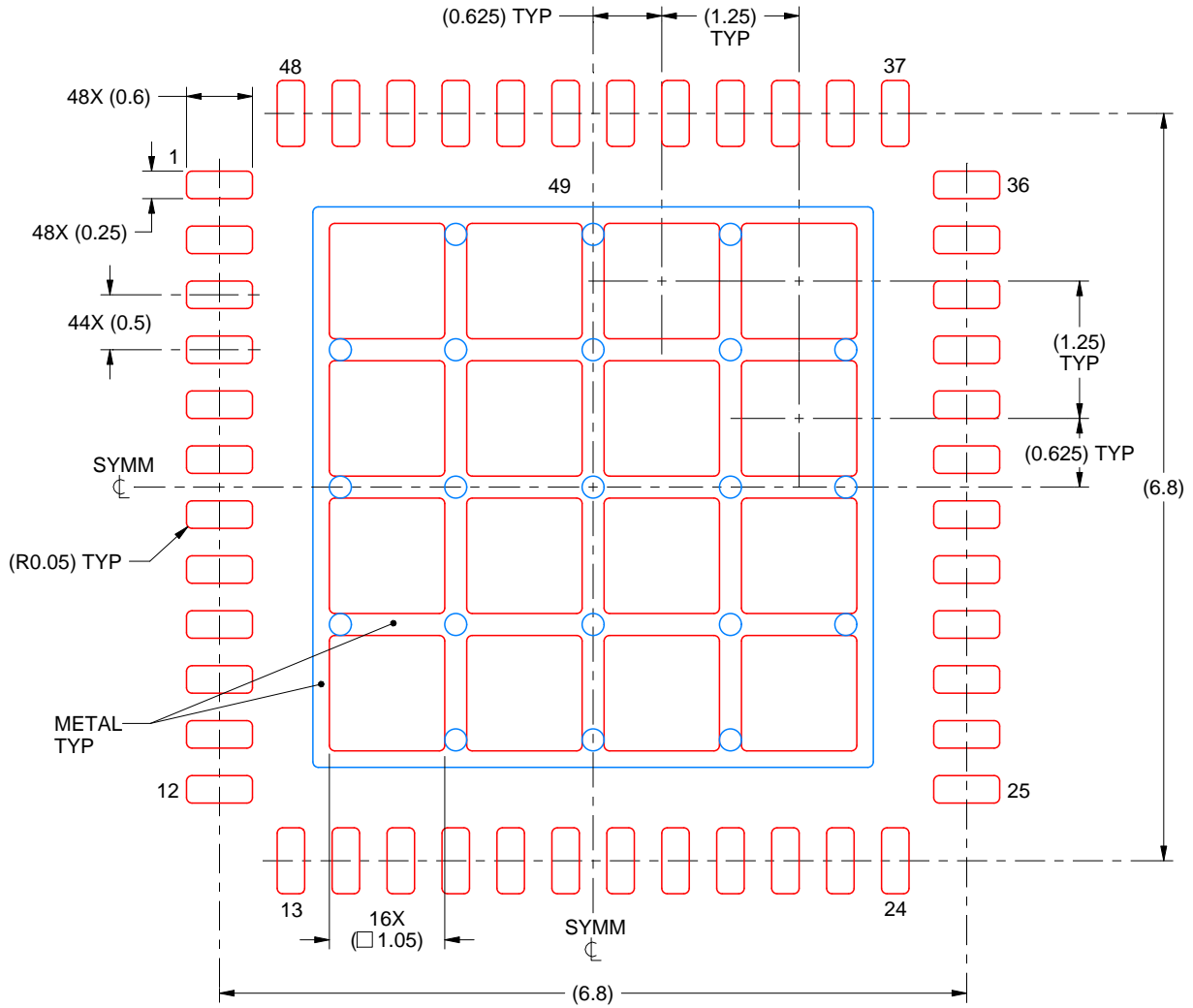

SOLDER PASTE EXAMPLE
 BASED ON 0.125 mm THICK STENCIL

EXPOSED PAD 49
 68% PRINTED SOLDER COVERAGE BY AREA UNDER PACKAGE
 SCALE:15X

4214990/B 04/2018

NOTES: (continued)

6. Laser cutting apertures with trapezoidal walls and rounded corners may offer better paste release. IPC-7525 may have alternate design recommendations.

RSB0040A

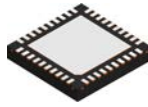

PACKAGE OUTLINE

WQFN - 0.8 mm max height

PLASTIC QUAD FLATPACK - NO LEAD

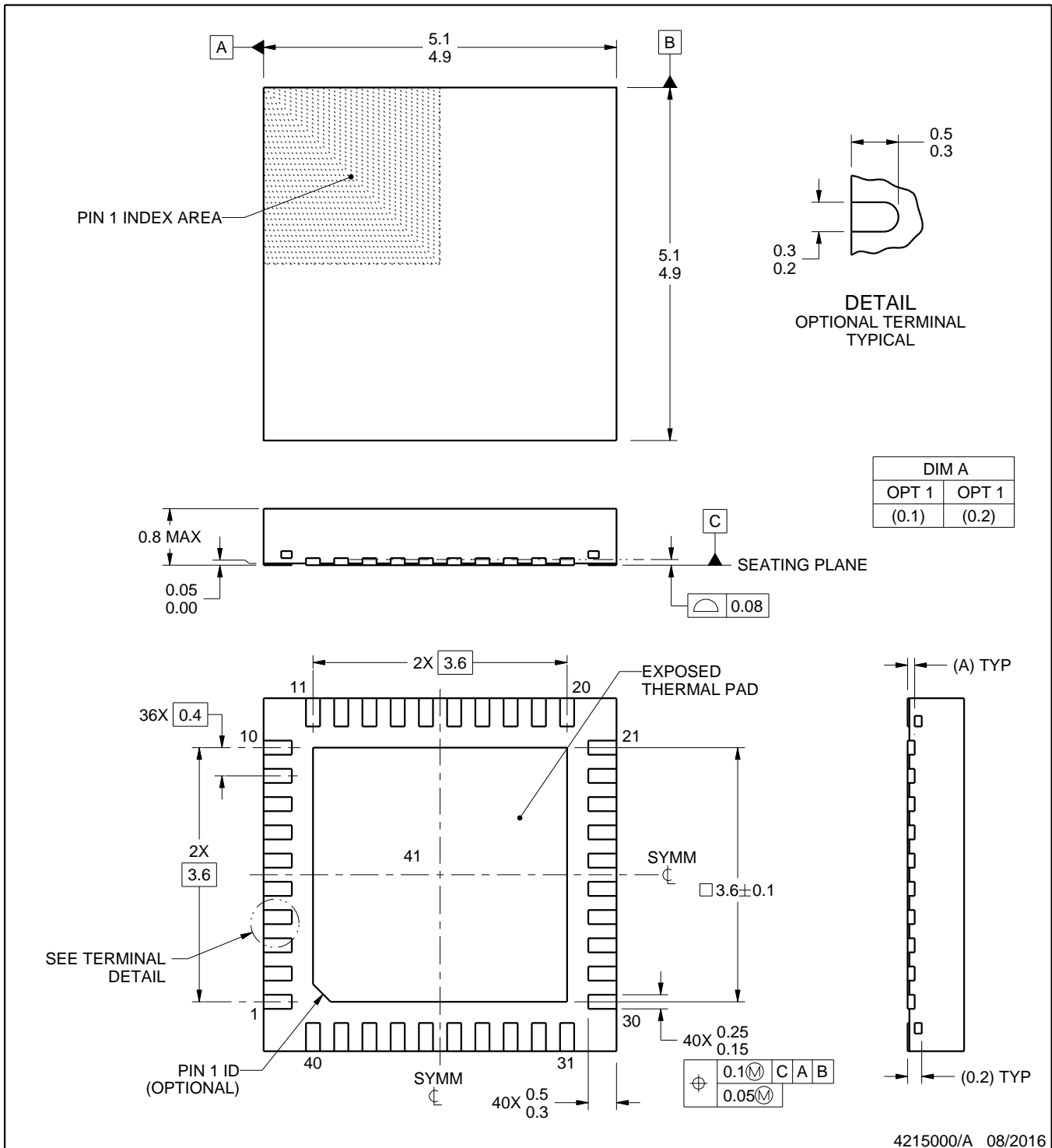

4215000/A 08/2016

NOTES:

1. All linear dimensions are in millimeters. Any dimensions in parenthesis are for reference only. Dimensioning and tolerancing per ASME Y14.5M.
2. This drawing is subject to change without notice.
3. The package thermal pad must be soldered to the printed circuit board for thermal and mechanical performance.

EXAMPLE BOARD LAYOUT

RSB0040A

WQFN - 0.8 mm max height

PLASTIC QUAD FLATPACK - NO LEAD

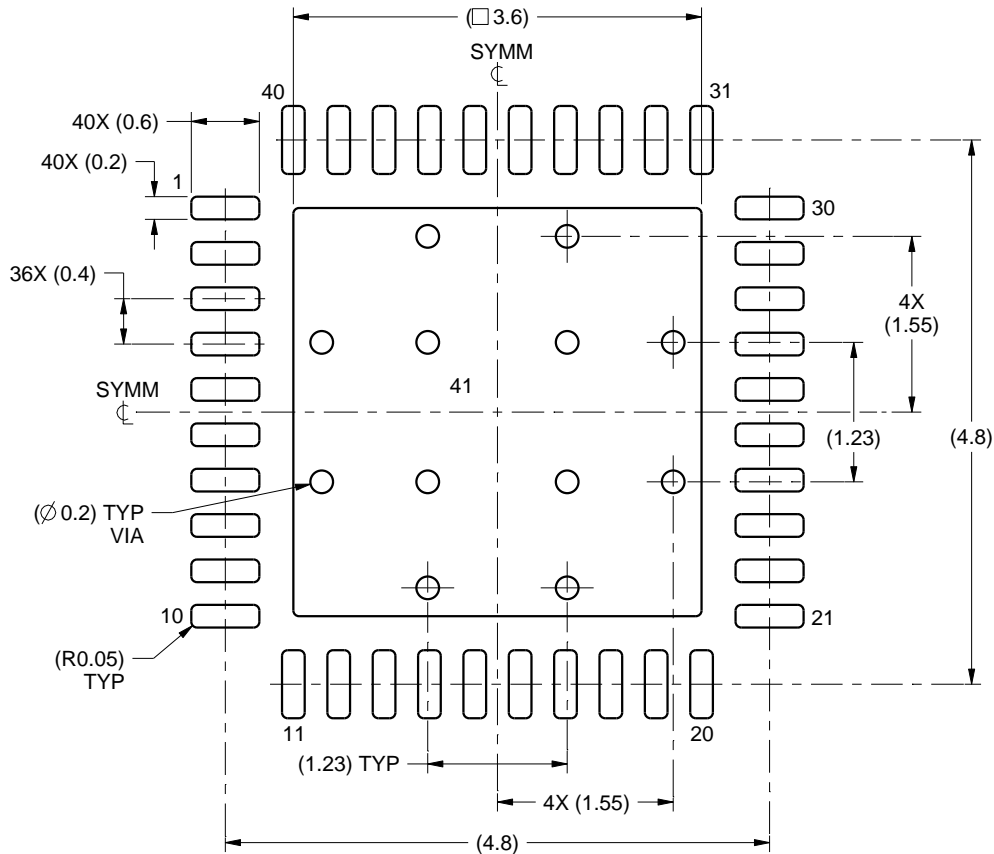

LAND PATTERN EXAMPLE
SCALE:15X

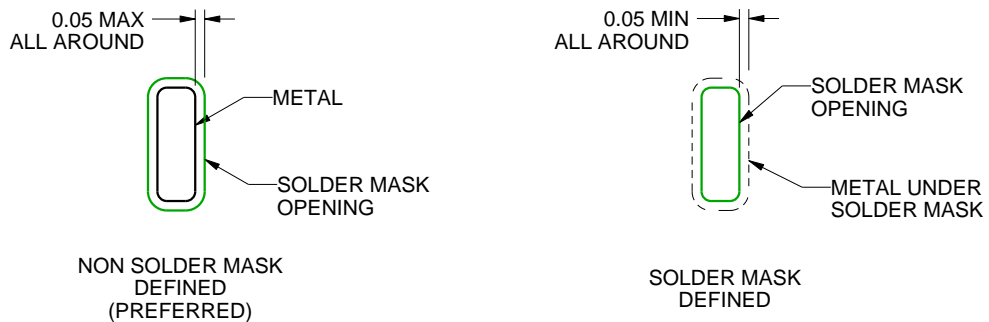

SOLDER MASK DETAILS

4215000/A 08/2016

NOTES: (continued)

4. This package is designed to be soldered to a thermal pad on the board. For more information, see Texas Instruments literature number SLUA271 (www.ti.com/lit/sluea271).
5. Vias are optional depending on application, refer to device data sheet. If any vias are implemented, refer to their locations shown on this view. It is recommended that vias under paste be filled, plugged or tented.

EXAMPLE STENCIL DESIGN

RSB0040A

WQFN - 0.8 mm max height

PLASTIC QUAD FLATPACK - NO LEAD

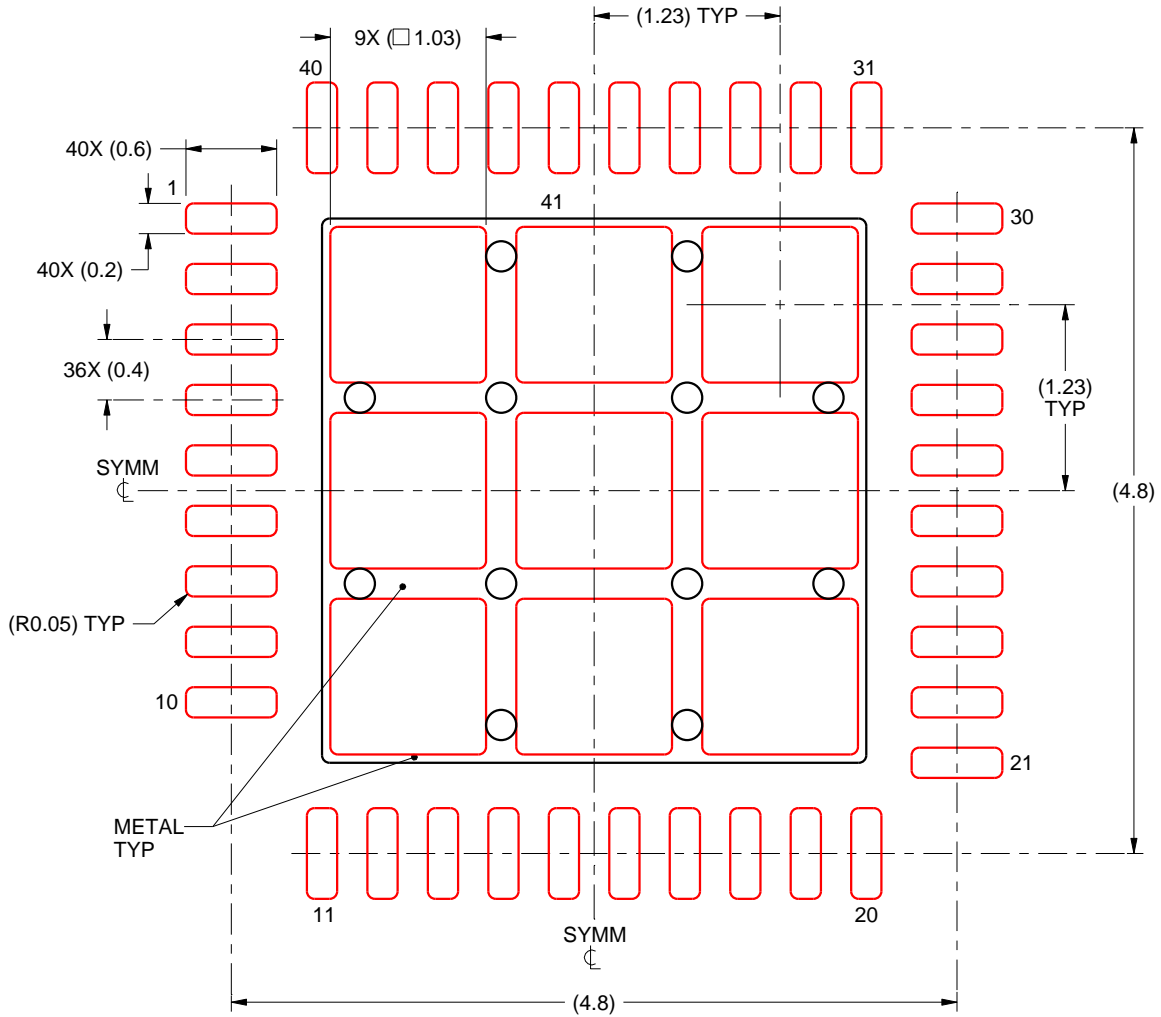

SOLDER PASTE EXAMPLE
BASED ON 0.1 mm THICK STENCIL

EXPOSED PAD 41
73.7% PRINTED SOLDER COVERAGE BY AREA UNDER PACKAGE
SCALE:20X

4215000/A 08/2016

NOTES: (continued)

6. Laser cutting apertures with trapezoidal walls and rounded corners may offer better paste release. IPC-7525 may have alternate design recommendations.

IMPORTANT NOTICE AND DISCLAIMER

TI PROVIDES TECHNICAL AND RELIABILITY DATA (INCLUDING DATASHEETS), DESIGN RESOURCES (INCLUDING REFERENCE DESIGNS), APPLICATION OR OTHER DESIGN ADVICE, WEB TOOLS, SAFETY INFORMATION, AND OTHER RESOURCES "AS IS" AND WITH ALL FAULTS, AND DISCLAIMS ALL WARRANTIES, EXPRESS AND IMPLIED, INCLUDING WITHOUT LIMITATION ANY IMPLIED WARRANTIES OF MERCHANTABILITY, FITNESS FOR A PARTICULAR PURPOSE OR NON-INFRINGEMENT OF THIRD PARTY INTELLECTUAL PROPERTY RIGHTS.

These resources are intended for skilled developers designing with TI products. You are solely responsible for (1) selecting the appropriate TI products for your application, (2) designing, validating and testing your application, and (3) ensuring your application meets applicable standards, and any other safety, security, or other requirements. These resources are subject to change without notice. TI grants you permission to use these resources only for development of an application that uses the TI products described in the resource. Other reproduction and display of these resources is prohibited. No license is granted to any other TI intellectual property right or to any third party intellectual property right. TI disclaims responsibility for, and you will fully indemnify TI and its representatives against, any claims, damages, costs, losses, and liabilities arising out of your use of these resources.

TI's products are provided subject to TI's Terms of Sale (www.ti.com/legal/termsofsale.html) or other applicable terms available either on ti.com or provided in conjunction with such TI products. TI's provision of these resources does not expand or otherwise alter TI's applicable warranties or warranty disclaimers for TI products.

Mailing Address: Texas Instruments, Post Office Box 655303, Dallas, Texas 75265
Copyright © 2018, Texas Instruments Incorporated

Looking for pricing, stock, or lifecycle information?

Click below to explore more details on WIN SOURCE:

 [View LMH0356SQE-40/NOPB on WIN SOURCE](#)

 [Texas Instruments](#) Information

Optimize Your Supply Chain with WIN SOURCE Solutions

-  Global Sourcing Solution
-  Obsolete Management
-  Cost Control Management
-  Shortage Management
-  Alternative Solution
-  Excess Inventory Management