



## LMH0344 3-Gbps HD - SD SDI Adaptive Cable Equalizer

### 1 Features

- Compliant With ST 424, ST 292, ST 344, and ST 259<sup>(1)</sup>
- Supports DVB-ASI at 270 Mbps
- Wide Range of Data Rates: 125 Mbps to 2.97 Gbps
- Equalizes up to 120 Meters of Belden 1694A at 2.97 Gbps, up to 140 Meters of Belden 1694A at 1.485 Gbps, or up to 400 Meters of Belden 1694A at 270 Mbps
- Equalizes up to 120m of Belden 1694A at 2.97 Gbps With 0.3 UI Maximum Output Jitter
- Manual Bypass and Output Mute With a Programmable Threshold
- Single-Ended or Differential Input
- 50-Ω Differential Outputs (Internal 50-Ω Pullups)
- Single 3.3-V Supply Operation
- 280-mW Typical Power Consumption
- 16-Pin WQFN or 25-Ball CS-BGA Package
- Industrial Temperature Range: -40°C to +85°C
- HBM ESD Rating: 8 kV
- WQFN Version Footprint Compatible With the LMH0044, LMH0384, and LMH0074
- Replaces the Semtech GS2974A or GS2974B

### 2 Applications

- ST 424, ST 292, ST 344, and ST 259 Serial Digital Interfaces<sup>(1)</sup>
- Serial Digital Data Equalization and Reception
- Data Recovery Equalization

### 3 Description

The LMH0344 3-Gbps HD – SD SDI Adaptive Cable Equalizer is designed to equalize data transmitted over cable (or any media with similar dispersive loss characteristics). The equalizer operates over a wide range of data rates from 125 Mbps to 2.97 Gbps and supports ST 424, ST 292, ST 344, and ST 259.

The LMH0344 device implements DC restoration to correctly handle pathological data conditions. The equalizer may be driven in either a single-ended or differential configuration.

Additional features include separate carrier detect and output mute pins which may be tied together to mute the output when no signal is present. A programmable mute reference is provided to mute the output at a selectable level of signal degradation.

For applications using the 4:4:4:4 10 bits video format, the LMH0394 cable equalizer will provide better performance.

The device is available in two space-saving packages: a 4-mm × 4-mm 16-pin WQFN and even more space-efficient 3-mm × 3-mm 25-ball CS-BGA package.

#### Device Information<sup>(1)</sup>

PART NUMBER	PACKAGE	BODY SIZE (NOM)
LMH0344	WQFN (16)	4.00 mm × 4.00 mm
	CS-BGA (25)	3.00 mm × 3.00 mm

(1) For all available packages, see the orderable addendum at the end of the data sheet.

(1) Due to SMPTE naming convention, all SMPTE Engineering Documents will be numbered as a two-letter prefix and a number. Documents and references with the same root number and year are functionally identical; for example ST 424-2006 and SMPTE 424M-2006 refer to the same document.

#### Functional Block Diagram

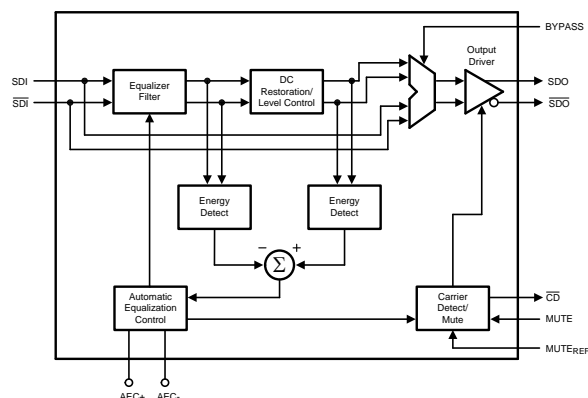

## Table of Contents

<b>1 Features</b> ..... 1 <b>2 Applications</b> ..... 1 <b>3 Description</b> ..... 1 <b>4 Revision History</b> ..... 2 <b>5 Pin Configurations and Functions</b> ..... 3 <b>6 Specifications</b> ..... 6 6.1 Absolute Maximum Ratings ..... 6 6.2 ESD Ratings..... 6 6.3 Recommended Operating Conditions..... 6 6.4 Thermal Information ..... 6 6.5 DC Electrical Characteristics ..... 6 6.6 AC Electrical Characteristics..... 7 6.7 Typical Characteristics ..... 8 <b>7 Detailed Description</b> ..... 9 7.1 Overview ..... 9 7.2 Functional Block Diagram ..... 9 7.3 Feature Description..... 9	7.4 Device Functional Modes..... 10 <b>8 Application and Implementation</b> ..... 11 8.1 Application Information..... 11 8.2 Typical Application ..... 11 8.3 Dos and Don'ts..... 13 <b>9 Power Supply Recommendations</b> ..... 13 <b>10 Layout</b> ..... 14 10.1 Layout Guidelines ..... 14 10.2 Layout Example ..... 15 <b>11 Device and Documentation Support</b> ..... 16 11.1 Documentation Support ..... 16 11.2 Community Resources..... 16 11.3 Trademarks ..... 16 11.4 Electrostatic Discharge Caution..... 16 11.5 Glossary ..... 16 <b>12 Mechanical, Packaging, and Orderable Information</b> ..... 16
--	---

## 4 Revision History

NOTE: Page numbers for previous revisions may differ from page numbers in the current version.

Changes from Revision N (June 2015) to Revision O	Page
<ul style="list-style-type: none"> <li>• Fixed typo in <i>Features</i> bullet to change "Equalizes up 120m of Belden 1694A" to "Equalizes up to 120m of Belden 1694A" ..... 1</li> </ul>	1
Changes from Revision M (January 2014) to Revision N	Page
<ul style="list-style-type: none"> <li>• Added, updated, or renamed the following sections: <i>Device Information Table</i>, <i>Pin Configuration and Functions</i>; <i>Specifications</i>; <i>Applications and Implementation</i>; <i>Detailed Description</i>; <i>Layout</i>; <i>Device and Documentation Support</i>; <i>Mechanical, Packaging, and Ordering Information</i> ..... 1</li> <li>• Changed "RGBa data patterns" to "4:4:4 10-bit video format" in <i>Description</i> section ..... 1</li> </ul>	1
Changes from Revision L (April 2013) to Revision M	Page
<ul style="list-style-type: none"> <li>• Added BYPASS Sentence..... 3</li> <li>• Added BYPASS Sentence..... 4</li> </ul>	4
Changes from Revision K (April 2013) to Revision L	Page
<ul style="list-style-type: none"> <li>• Changed layout of National Data Sheet to TI format ..... 10</li> </ul>	10

## 5 Pin Configurations and Functions

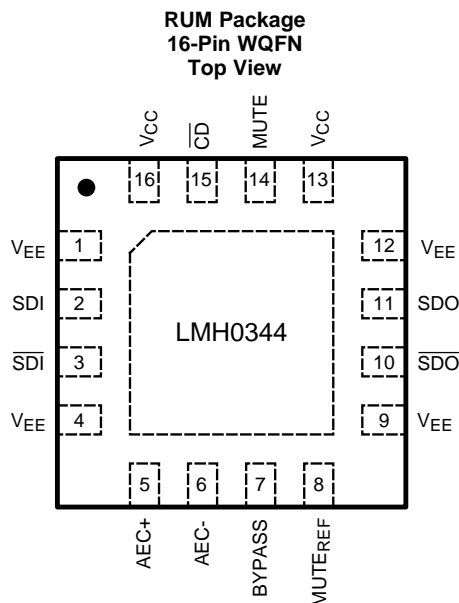

The exposed die attach pad is a negative electrical terminal for this device. It should be connected to the negative power supply voltage.

### Pin Functions – RUM Package

PIN		I/O	DESCRIPTION
NAME	WQFN		
AEC+	5	I/O, Analog	AEC loop filter external capacitor (1- $\mu$ F) positive connection.
AEC-	6	I/O, Analog	AEC loop filter external capacitor (1- $\mu$ F) negative connection.
BYPASS	7	I, LVCMOS	Bypasses equalization and DC restoration when high. No equalization occurs in this mode. This pin does not have an internal pulldown. If the bypass function is not used, this pin requires an external pulldown resistor to disable bypass.
$\overline{CD}$	15	O, LVCMOS	Carrier detect. $\overline{CD}$ is high when no signal is present. $\overline{CD}$ has no function in BYPASS mode.
MUTE	14	I, LVCMOS	Output mute. To disable the mute function and enable the output, MUTE must be tied to GND or a low level signal. To force the outputs to a muted state, tie to $V_{CC}$ . $\overline{CD}$ may be tied to this pin to inhibit the output when no input signal is present. MUTE has no function in BYPASS mode.
MUTE <sub>REF</sub>	8	I, Analog	Mute reference. Sets the threshold for $\overline{CD}$ and (with $\overline{CD}$ tied to MUTE) determines the maximum cable to be equalized before muting. MUTE <sub>REF</sub> may be either unconnected or connected to ground for maximum equalization.
NC	—	—	No connect.
SDI	2	I, Analog	Serial data true input.
$\overline{SDI}$	3	I, Analog	Serial data complement input.
SDO	11	O, Analog	Serial data true output.
$\overline{SDO}$	10	O, Analog	Serial data complement output.
$V_{CC}$	13	Power	Positive power supply (+3.3V).
	16		
$V_{EE}$	DAP	Ground	Negative power supply (ground). Note <a href="#">Figure 7</a> for layout example.
	1		
	4		
	9		
	12		

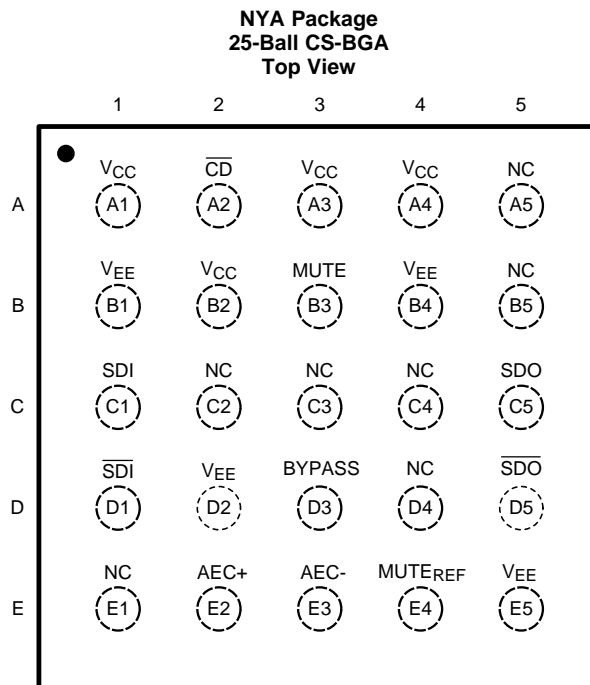

**Pin Functions – NYA Package**

PIN		I/O	DESCRIPTION
NAME	CS-BGA BALL		
AEC+	E2	I/O, Analog	AEC loop filter external capacitor (1-μF) positive connection.
AEC-	E3	I/O, Analog	AEC loop filter external capacitor (1-μF) negative connection.
BYPASS	D3	I, LVCMOS	Bypasses equalization and DC restoration when high. No equalization occurs in this mode. This pin does not have an internal pulldown. If the bypass function is not used, this pin requires an external pulldown resistor to disable bypass.
$\overline{CD}$	A2	O, LVCMOS	Carrier detect. $\overline{CD}$ is high when no signal is present. $\overline{CD}$ has no function in BYPASS mode.
MUTE	B3	I, LVCMOS	Output mute. To disable the mute function and enable the output, MUTE must be tied to GND or a low level signal. To force the outputs to a muted state, tie to $V_{CC}$ . $\overline{CD}$ may be tied to this pin to inhibit the output when no input signal is present. MUTE has no function in BYPASS mode.
MUTE <sub>REF</sub>	E4	I, Analog	Mute reference. Sets the threshold for $\overline{CD}$ and (with $\overline{CD}$ tied to MUTE) determines the maximum cable to be equalized before muting. MUTE <sub>REF</sub> may be either unconnected or connected to ground for maximum equalization.
NC	A5	—	No connect.
	B5		
	C2		
	C3		
	C4		
	D4		
E1			
SDI	C1	I, Analog	Serial data true input.
$\overline{SDI}$	D1	I, Analog	Serial data complement input.
SDO	C5	O, Analog	Serial data true output.
$\overline{SDO}$	D5	O, Analog	Serial data complement output.

**Pin Functions – NYA Package (continued)**

PIN		I/O	DESCRIPTION
NAME	CS-BGA BALL		
V <sub>CC</sub>	A1	Power	Positive power supply (+3.3V).
	A3		
	A4		
	B2		
V <sub>EE</sub>	B1	Ground	Negative power supply (ground).
	B4		
	D2		
	E5		

## 6 Specifications

### 6.1 Absolute Maximum Ratings

over operating free-air temperature range (unless otherwise noted)<sup>(1)</sup>

	MIN	MAX	UNIT
Supply voltage		4	V
Input voltage (all inputs)		-0.3 to $V_{CC}+0.3$	V
Junction temperature		125	°C
Lead temperature (soldering 4 seconds)		260	°C
Storage temperature	-65	150	°C

- (1) Stresses beyond those listed under *Absolute Maximum Ratings* may cause permanent damage to the device. These are stress ratings only, which do not imply functional operation of the device at these or any other conditions beyond those indicated under *Recommended Operating Conditions*. Exposure to absolute-maximum-rated conditions for extended periods may affect device reliability.

### 6.2 ESD Ratings

		VALUE	UNIT
$V_{(ESD)}$ Electrostatic discharge	Human body model (HBM), per ANSI/ESDA/JEDEC JS-001 <sup>(1)</sup>	±8000	V
	Charged-device model (CDM), per JEDEC specification JESD22-C101 <sup>(2)</sup>	±2000	
	Machine model (MM)	400	

- (1) JEDEC document JEP155 states that 500-V HBM allows safe manufacturing with a standard ESD control process. Manufacturing with less than 500-V HBM is possible with the necessary precautions. Pins listed as ±8000 V may actually have higher performance.
- (2) JEDEC document JEP157 states that 250-V CDM allows safe manufacturing with a standard ESD control process. Manufacturing with less than 250-V CDM is possible with the necessary precautions. Pins listed as ±2000 V may actually have higher performance.

### 6.3 Recommended Operating Conditions

		MIN	TYP	MAX	UNIT
$(V_{CC} - V_{EE})$	Supply Voltage	3.135	3.3	3.465	V
	Input Coupling Capacitance		1		μF
	AEC Capacitor (Connected between AEC+ and AEC-)		1		μF
$T_A$	Operating Free Air Temperature	-40	25	85	°C

### 6.4 Thermal Information

THERMAL METRIC <sup>(1)</sup>		LMH0344		UNIT
		RUM (WQFN)	NYA (CS-BGA)	
		16 PINS	25 BALL	
$R_{\theta JA}$	Junction-to-ambient thermal resistance	40	58.1	°C/W
$R_{\theta JC(top)}$	Junction-to-case (top) thermal resistance	4.5	—	°C/W

- (1) For more information about traditional and new thermal metrics, see the *Semiconductor and IC Package Thermal Metrics* application report, [SPRA953](#).

### 6.5 DC Electrical Characteristics

over Supply Voltage and Operating Temperature ranges, unless otherwise specified<sup>(1)(2)</sup>.

PARAMETER	TEST CONDITIONS	MIN	TYP	MAX	UNIT	
$V_{CMIN}$	Input Common-Mode Voltage		1.9		V	
$V_{SDI}$	Input Voltage Swing (SDI, $\overline{SDI}$ )	At LMH0344 input <sup>(3)(4)</sup>	720	800	950	mV <sub>P-P</sub>
$V_{CMOUT}$	Output Common-Mode Voltage (SDO, $\overline{SDO}$ )		$V_{CC} - V_{SDO}/2$		V	
$V_{SDO}$	Output Voltage Swing	100-Ω load, differential	750		mV <sub>P-P</sub>	

- (1) Current flow into device pins is defined as positive. Current flow out of device pins is defined as negative. All voltages are stated referenced to  $V_{EE} = 0$  Volts.
- (2) Typical values are stated for  $V_{CC} = +3.3$  V and  $T_A = +25^\circ\text{C}$ .
- (3) Specification is ensured by characterization.
- (4) This specification is for 1m cable only.

## DC Electrical Characteristics (continued)

over Supply Voltage and Operating Temperature ranges, unless otherwise specified<sup>(1)(2)</sup>.

PARAMETER	TEST CONDITIONS	MIN	TYP	MAX	UNIT
MUTE <sub>R</sub> EF	MUTE <sub>REF</sub> DC Voltage (floating)		1.3		V
	MUTE <sub>REF</sub> Range		0.6		V
	CD Output Voltage	Carrier not present	2.4		V
		Carrier present		0.4	V
	MUTE Input Voltage	Min to mute outputs	2.0		V
		Max to force outputs active		0.8	V
I <sub>CC</sub>	Supply Current		85	100	mA

## 6.6 AC Electrical Characteristics

over Supply Voltage and Operating Temperature ranges, unless otherwise specified<sup>(1)(2)</sup>.

PARAMETER	TEST CONDITIONS	MIN	TYP	MAX	UNIT
BR <sub>MIN</sub>	Minimum Input Data Rate (SDI, SDI)	143			Mbps
BR <sub>Max</sub>	Maximum Input Data Rate (SDI, SDI)			2970	Mbps
T <sub>JRaw</sub>	Jitter for Various Cable Lengths	270 Mbps, Belden 1694A, 0 to 400 meters <sup>(3)</sup>		0.2	UI
		270 Mbps, Belden 1694A, 0 to 400 meters <sup>(4)</sup>		0.07	
		1.485 Gbps, Belden 1694A, 0 to 140 meters <sup>(3)</sup>		0.25	
		1.485 Gbps, Belden 1694A, 0-140 meters <sup>(4)</sup>		0.08	
		2.97 Gbps, Belden 1694A, 0 to 120 meters <sup>(3)</sup>		0.3	
		2.97 Gbps, Belden 1694A, 0 to 120 meters <sup>(4)</sup>		0.18	
t <sub>r</sub> , t <sub>f</sub>	Output Rise Time, Fall Time (SDO, SDO)	20% to 80% <sup>(5)</sup>	60	130	ps
T <sub>R_F_Del</sub> ta	Mismatch in Rise/Fall Time (SDO, SDO)	See <sup>(5)</sup>	2	15	ps
t <sub>OS</sub>	Output Overshoot (SDO, SDO)	See <sup>(5)</sup>	1%	5%	
R <sub>OUT</sub>	Output Resistance (SDO, SDO)	single-ended	50		Ω
RL <sub>IN</sub>	Input Return Loss (SDI, SDI)	5 MHz to 1.5 GHz <sup>(6)</sup>	15		dB
		1.5 GHz to 3.0 GHz <sup>(6)</sup>	10		dB
R <sub>IN</sub>	Input Resistance (SDI, SDI)	single-ended	1.3		kΩ
C <sub>IN</sub>	Input Capacitance (SDI, SDI)	single-ended	1		pF

(1) Typical values are stated for V<sub>CC</sub> = +3.3 V and T<sub>A</sub> = +25°C.

(2) Due to SMPTE naming convention, all SMPTE Engineering Documents will be numbered as a two-letter prefix and a number. Documents and references with the same root number and year are functionally identical; for example ST 424-2006 and SMPTE 424M-2006 refer to the same document.

(3) Based on characterization data over the full range of recommended operating conditions of the device. Jitter is measured in accordance with RP 184, RP 192, and the applicable serial data transmission standard: ST 424, ST 292, or ST 259.

(4) Measured with Pseudo Matrix Pathological test signal.

(5) Specification is ensured by characterization.

(6) Input return loss is dependent onboard design. The LMH0344 exceeds this specification on the SD344 evaluation board with a return loss network consisting of an 8.2-nH inductor in parallel with a 0.5-pF capacitor in parallel with the 75Ω series resistor on the input.

## 6.7 Typical Characteristics

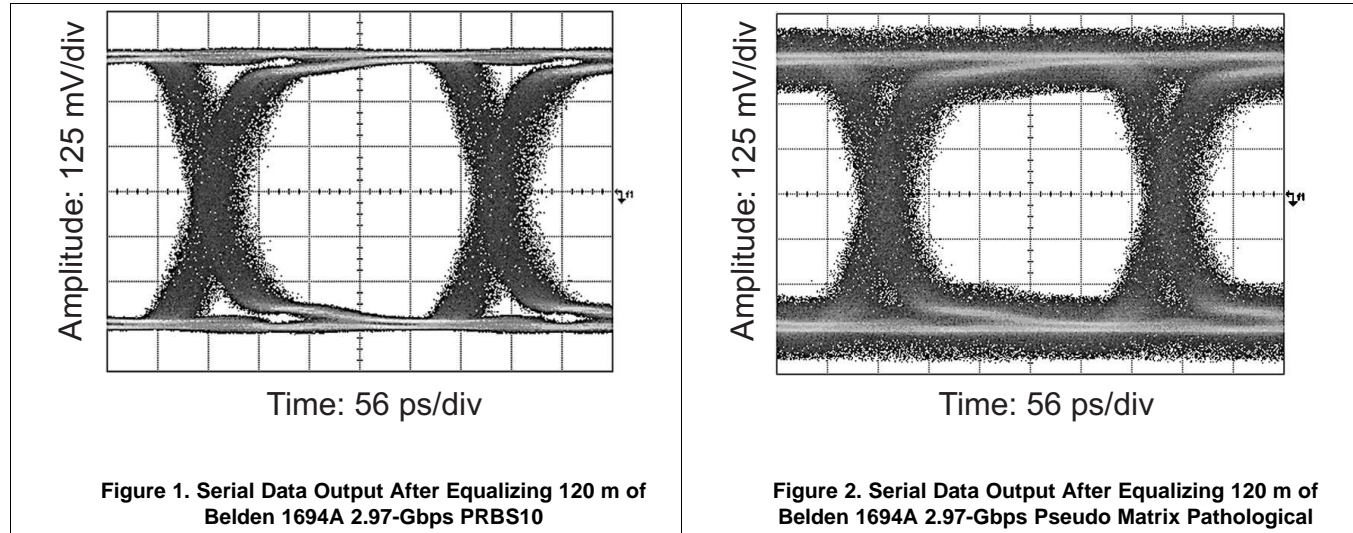

## 7 Detailed Description

### 7.1 Overview

The LMH0344 3-Gbps HD-SD SDI Adaptive Cable Equalizer is designed to equalize data transmitted over cable or any other media with similar dispersive loss characteristics. The equalizer operates over a wide range of data rates from 125 Mbps to 2.97 Gbps and supports ST 424, ST 292, ST 344, and ST 259.

### 7.2 Functional Block Diagram

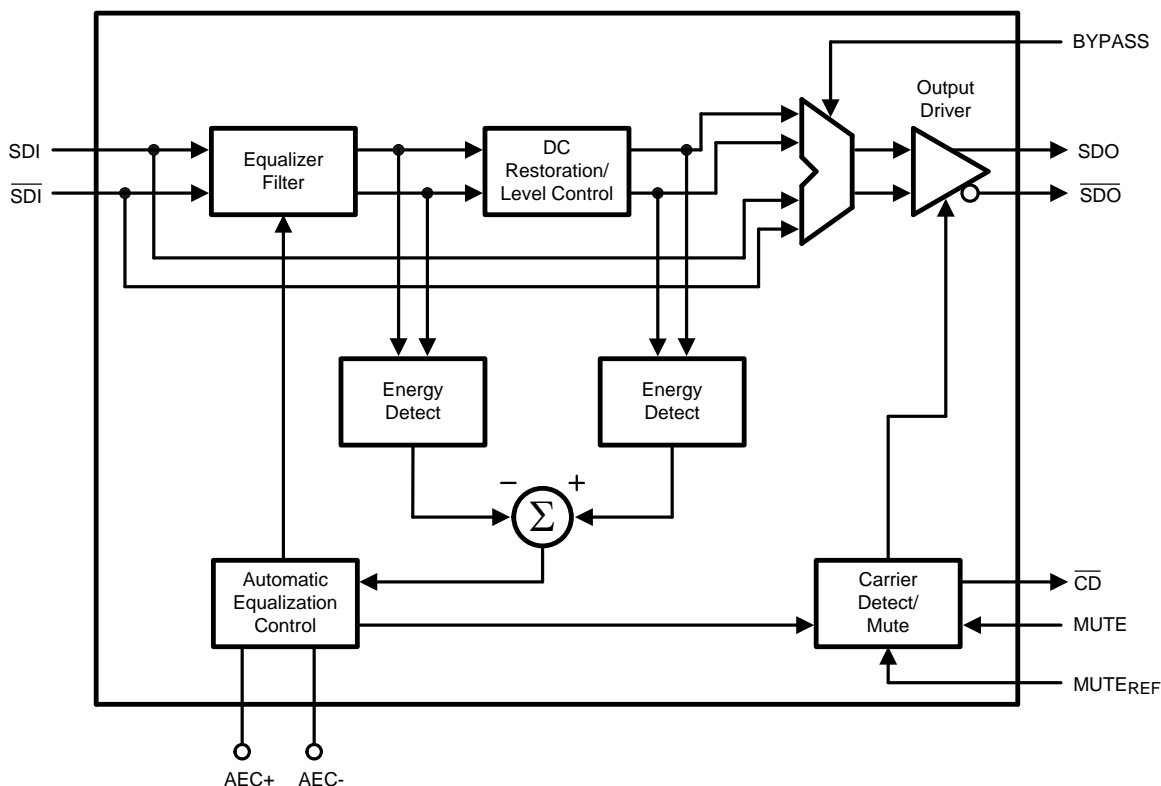

### 7.3 Feature Description

#### 7.3.1 Block Description

The **Equalizer Filter** block is a multistage adaptive filter. If **BYPASS** is high, the equalizer filter is disabled.

The **DC Restoration / Level Control** block receives the differential signals from the equalizer filter block. This block incorporates a self-biasing DC restoration circuit to fully DC restore the signals. If **BYPASS** is high, this function is disabled.

The signals before and after the DC Restoration / Level Control block are used to generate the **Automatic Equalization Control (AEC)** signal. This control signal sets the gain and bandwidth of the equalizer filter. The loop response in the AEC block is controlled by an external 1- $\mu$ F capacitor placed across the **AEC+** and **AEC-** pins.

The **Carrier Detect / Mute** block generates the carrier detect signal and controls the mute function of the output. This block uses the **CD** and **MUTE** signals along with **Mute Reference (MUTEREf)**.

The **Output Driver** produces **SDO** and **SDO**.

## Feature Description (continued)

### 7.3.2 Mute Reference (MUTE<sub>REF</sub>)

The mute reference sets the threshold for  $\overline{CD}$  and (with  $\overline{CD}$  tied to MUTE) determines the amount of cable to equalize before automatically muting the outputs. This is set by applying a voltage inversely proportional to the length of cable to equalize. The applied voltage must be greater than the MUTE<sub>REF</sub> floating voltage (typically 1.3 V) to change the  $\overline{CD}$  threshold. As the applied MUTE<sub>REF</sub> voltage is increased, the amount of cable that can be equalized before carrier detect is deasserted and the outputs are muted is decreased. MUTE<sub>REF</sub> may be left unconnected or connected to ground for maximum equalization before muting.

### 7.3.3 Carrier Detect ( $\overline{CD}$ ) and Mute

Carrier detect  $\overline{CD}$  indicates if a valid signal is present at the LMH0344 input. If MUTE<sub>REF</sub> is used, the carrier detect threshold will be altered accordingly.  $\overline{CD}$  provides a high voltage when no signal is present at the LMH0344 input.  $\overline{CD}$  is low when a valid input signal is detected.

MUTE can be used to manually mute or enable SDO and  $\overline{SDO}$ . Applying a high input to MUTE will mute the LMH0344 outputs by forcing the output to a logic zero. Applying a low input will force the outputs to be active.

$\overline{CD}$  and MUTE may be tied together to automatically mute the output when no input signal is present.

### 7.3.4 Input Interfacing

The LMH0344 accepts either differential or single-ended input. The input must be AC-coupled. Transformer coupling is not supported.

The LMH0344 correctly handles equalizer pathological signals for standard definition and high definition serial digital video, as described in SMPTE RP 178 and RP 198, respectively.

### 7.3.5 Output Interfacing

The SDO and  $\overline{SDO}$  outputs are internally loaded with 50  $\Omega$ . These outputs produce a 750-mV<sub>P-P</sub> differential output, or a 375-mV<sub>P-P</sub> single-ended output.

## 7.4 Device Functional Modes

The LMH0344 features can be programmed using pin mode only.

## 8 Application and Implementation

### NOTE

Information in the following applications sections is not part of the TI component specification, and TI does not warrant its accuracy or completeness. TI's customers are responsible for determining suitability of components for their purposes. Customers should validate and test their design implementation to confirm system functionality.

### 8.1 Application Information

The LMH0344 is a single channel 3 Gbps HD – SD SDI Adaptive Cable Equalizer designed to equalize data transmitted over cable or any media with similar dispersive loss characteristics. The equalizer operates over a wide range of data rates from 125 Mbps to 2.97 Gbps and supports ST 424, ST 292, ST 344, and ST 259. Additional features include separate carrier detect and output mute pins which may be tied together to mute the output when no signal is present. A programmable mute reference is provided to mute the output at a selectable level of signal degradation. The bypass pin allows the adaptive equalizer to be bypassed.

The LMH0344 accepts either a differential or single-ended input. The input must be AC-coupled. The LMH0344 correctly handles equalizer pathological signals for standard definition and high definition serial digital video, as described in RP 178 and RP 198, respectively.

### 8.2 Typical Application

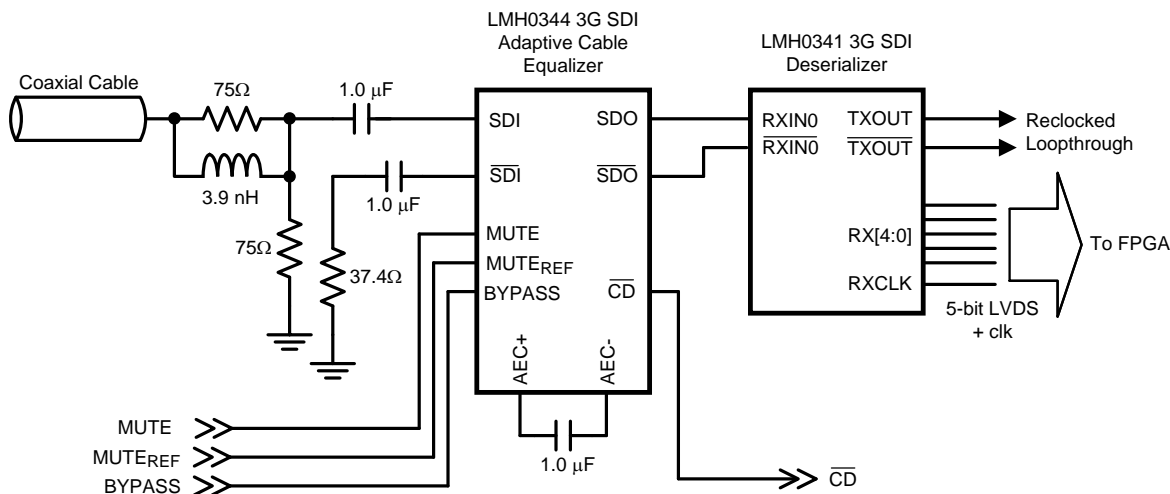

Figure 3. Typical 2.97-Gbps SDI De-Serializer Application

## Typical Application (continued)

### 8.2.1 Design Requirements

Table 1 lists the design parameters for the LMH0344.

**Table 1. LMH0344 Design Parameters**

DESIGN PARAMETER	REQUIREMENT
Input AC-coupling capacitors	Required. A common type of AC-coupling capacitor is 1 $\mu\text{F} \pm 10\%$ X7R ceramic capacitor (0402 or 0201 size). Capacitors may be implemented on the PCB or in the connector.
Output AC-coupling capacitors	The user should check input common mode voltage of the device attached to SDO . If AC-coupling Capacitor is required, AC-coupling capacitor is expected to be 4.7 $\mu\text{F} \pm 10\%$ .
Input launch amplitude	Refer to <i>DC Electrical Characteristics</i> and <i>AC Electrical Characteristics</i> .

### 8.2.2 Detailed Design Procedure

To begin the design process, determine the following:

1. Maximum power draw for PCB regulator selection. Use maximum power consumption in the data sheet.
2. Closely compare schematic against typical connection diagram in the data sheet.
3. Plan out the PCB layout and component placement to minimize parasitic losses and reflections.
4. To optimize return loss result, return loss components may need to be adjusted.

### 8.2.3 Application Curves

Figure 4 and Figure 5 depict the differential output eye diagrams for SDO and  $\overline{\text{SDO}}$  at 2.97 Gbps using B1694A cable.

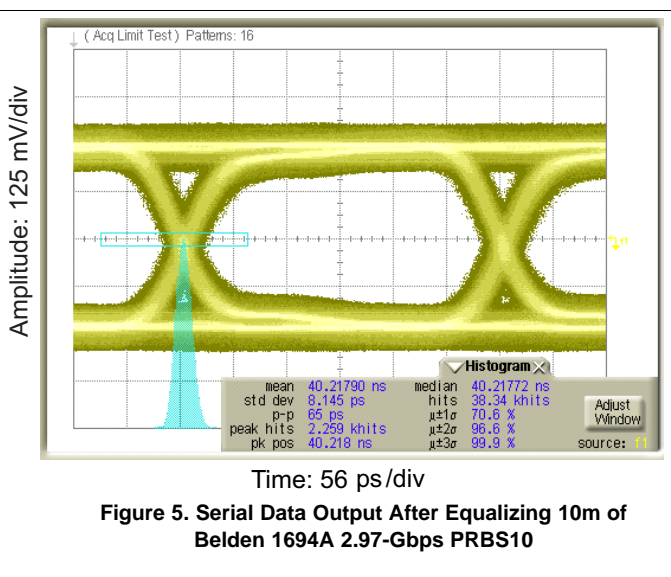
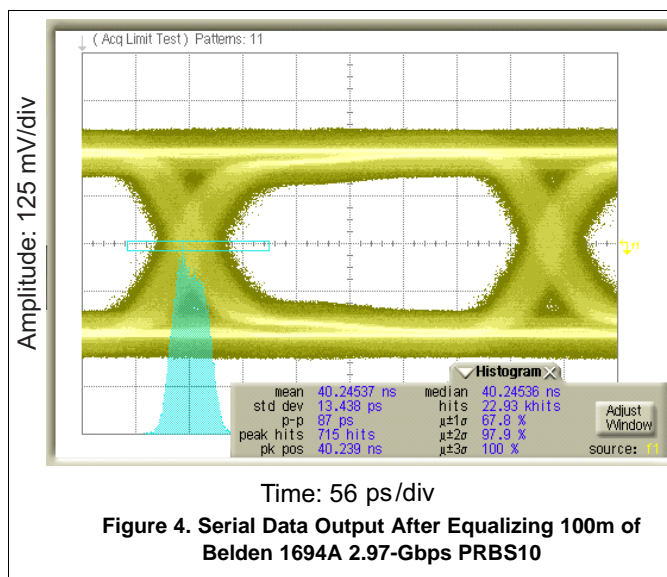

### 8.3 Dos and Don'ts

Pay special attention to the PCB layout for the high speed signals. The SMPTE organization specifies the requirements for the Serial Digital Interface to transport digital video at SD, HD, and 3 Gbps data rates over coaxial cables. One of the requirements is meeting the required Return Loss. This requirement specifies how closely the port resembles 75- $\Omega$  impedance across a specified frequency band. The SMPTE specifications also defines the use of AC-coupling capacitors for transporting uncompressed serial data streams with heavy low frequency content. This specification requires the use of a 1  $\mu$ F, AC-coupling capacitors on the input of the LMH0344 to avoid low frequency DC wander.

## 9 Power Supply Recommendations

Follow these general guidelines when designing the power supply:

1. The power supply should be designed to provide the recommended operating conditions in terms of DC voltage.
2. The maximum current draw for the LMH0344 is provided in the data sheet. This figure can be used to calculate the maximum current the supply must provide.
3. The LMH0344 does not require any special power supply filtering, provided the recommended operating conditions are met. Only standard supply decoupling is required.

## 10 Layout

### 10.1 Layout Guidelines

For information on layout and soldering of the WQFN package, please refer to the following application note: *AN-1187 Leadless Leadframe Package (LLP) (SNOA401)*.

The ST 424, 292, and 259 standards have stringent requirements for the input return loss of receivers, which essentially specify how closely the input must resemble a 75- $\Omega$  network. Any non-idealities in the network between the BNC and the equalizer will degrade the input return loss. Take care to minimize impedance discontinuities between the BNC and the equalizer to ensure that the characteristic impedance of this trace is 75  $\Omega$ .

Please consider the following PCB recommendations:

- Use surface-mount components, and use the smallest components available. In addition, use the smallest size component pads.
- Select trace widths that minimize the impedance mismatch between the BNC and the equalizer.
- Select a board stack up that supports both 75- $\Omega$  single-ended traces and 100- $\Omega$  loosely-coupled differential traces.
- Place return loss components closest to the equalizer input pins.
- Maintain symmetry on the complementary signals.
- Route 100- $\Omega$  traces uniformly (keep trace widths and trace spacing uniform along the trace).
- Avoid sharp bends in the signal path; use 45° or radial bends.
- Place bypass capacitors close to each power pin, and use the shortest path to connect equalizer power and ground pins to the respective power or ground planes.

## 10.2 Layout Example

Figure 6 and Figure 7 demonstrates the LMH0344EVM PCB layout. Ground and supply relief under the return loss passive components and pads reduces parasitic - improving return loss performance. Note in Figure 7 that the five vias between the four solder paste squares do not have solder paste. This practice improves both thermal performance and soldering during board assembly.

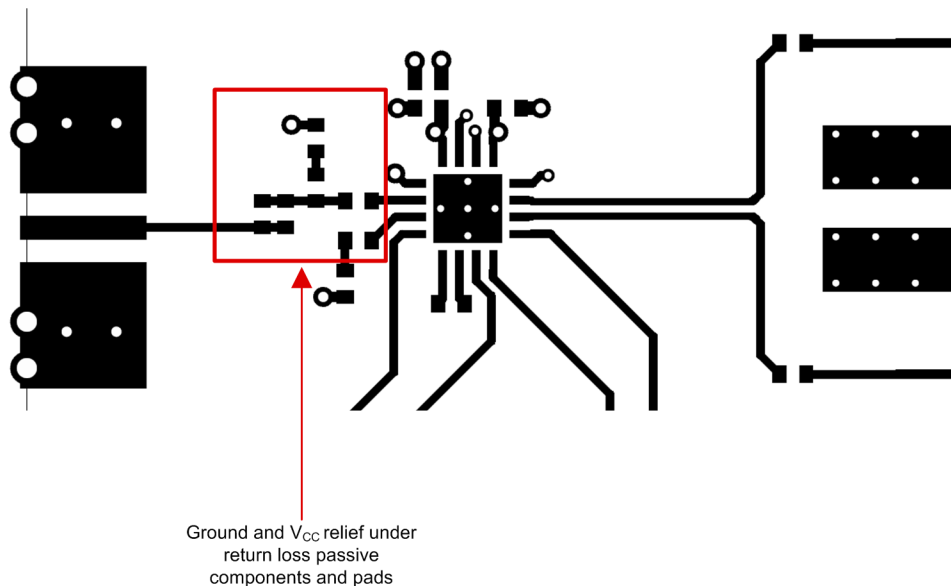

Figure 6. LMH0344EVM Top Etch Layout Example

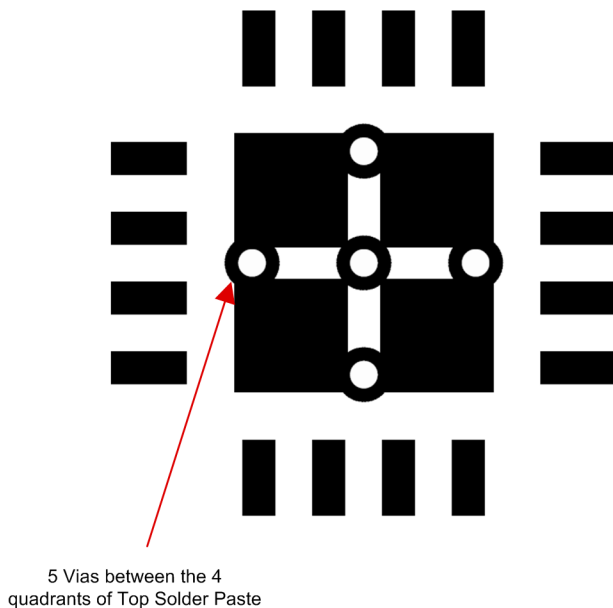

Figure 7. LMH0344EVM Top Solder Paste Mask

## 11 Device and Documentation Support

### 11.1 Documentation Support

#### 11.1.1 Related Documentation

For additional information, see the following:

Application Note AN- 1187, *Leadless Leadframe Package (LLP) (SNOA401)*.

### 11.2 Community Resources

The following links connect to TI community resources. Linked contents are provided "AS IS" by the respective contributors. They do not constitute TI specifications and do not necessarily reflect TI's views; see TI's [Terms of Use](#).

**TI E2E™ Online Community** *TI's Engineer-to-Engineer (E2E) Community*. Created to foster collaboration among engineers. At [e2e.ti.com](http://e2e.ti.com), you can ask questions, share knowledge, explore ideas and help solve problems with fellow engineers.

**Design Support** *TI's Design Support* Quickly find helpful E2E forums along with design support tools and contact information for technical support.

### 11.3 Trademarks

E2E is a trademark of Texas Instruments.  
All other trademarks are the property of their respective owners.

### 11.4 Electrostatic Discharge Caution



These devices have limited built-in ESD protection. The leads should be shorted together or the device placed in conductive foam during storage or handling to prevent electrostatic damage to the MOS gates.

### 11.5 Glossary

[SLYZ022](#) — *TI Glossary*.

This glossary lists and explains terms, acronyms, and definitions.

## 12 Mechanical, Packaging, and Orderable Information

The following pages include mechanical, packaging, and orderable information. This information is the most current data available for the designated devices. This data is subject to change without notice and revision of this document. For browser-based versions of this data sheet, refer to the left-hand navigation.

**PACKAGING INFORMATION**

Orderable Device	Status (1)	Package Type	Package Drawing	Pins	Package Qty	Eco Plan (2)	Lead/Ball Finish (6)	MSL Peak Temp (3)	Op Temp (°C)	Device Marking (4/5)	Samples
HPA02292SQ/NOPB	ACTIVE	WQFN	RUM	16	1000	Green (RoHS & no Sb/Br)	CU SN	Level-1-260C-UNLIM	-40 to 85	L0344	<a href="#">Samples</a>
LMH0344GR/NOPB	ACTIVE	csBGA	NYA	25	1000	Green (RoHS & no Sb/Br)	CU SNAGCU	Level-1-260C-UNLIM	-40 to 85	344G	<a href="#">Samples</a>
LMH0344GRE/NOPB	ACTIVE	csBGA	NYA	25	250	Green (RoHS & no Sb/Br)	CU SNAGCU	Level-1-260C-UNLIM	-40 to 85	344G	<a href="#">Samples</a>
LMH0344SQ/NOPB	ACTIVE	WQFN	RUM	16	1000	Green (RoHS & no Sb/Br)	CU SN	Level-1-260C-UNLIM	-40 to 85	L0344	<a href="#">Samples</a>
LMH0344SQE/NOPB	ACTIVE	WQFN	RUM	16	250	Green (RoHS & no Sb/Br)	CU SN	Level-1-260C-UNLIM	-40 to 85	L0344	<a href="#">Samples</a>
LMH0344SQX/NOPB	ACTIVE	WQFN	RUM	16	4500	Green (RoHS & no Sb/Br)	CU SN	Level-1-260C-UNLIM	-40 to 85	L0344	<a href="#">Samples</a>

(1) The marketing status values are defined as follows:

**ACTIVE:** Product device recommended for new designs.

**LIFEBUY:** TI has announced that the device will be discontinued, and a lifetime-buy period is in effect.

**NRND:** Not recommended for new designs. Device is in production to support existing customers, but TI does not recommend using this part in a new design.

**PREVIEW:** Device has been announced but is not in production. Samples may or may not be available.

**OBSELETE:** TI has discontinued the production of the device.

(2) Eco Plan - The planned eco-friendly classification: Pb-Free (RoHS), Pb-Free (RoHS Exempt), or Green (RoHS & no Sb/Br) - please check <http://www.ti.com/productcontent> for the latest availability information and additional product content details.

**TBD:** The Pb-Free/Green conversion plan has not been defined.

**Pb-Free (RoHS):** TI's terms "Lead-Free" or "Pb-Free" mean semiconductor products that are compatible with the current RoHS requirements for all 6 substances, including the requirement that lead not exceed 0.1% by weight in homogeneous materials. Where designed to be soldered at high temperatures, TI Pb-Free products are suitable for use in specified lead-free processes.

**Pb-Free (RoHS Exempt):** This component has a RoHS exemption for either 1) lead-based flip-chip solder bumps used between the die and package, or 2) lead-based die adhesive used between the die and leadframe. The component is otherwise considered Pb-Free (RoHS compatible) as defined above.

**Green (RoHS & no Sb/Br):** TI defines "Green" to mean Pb-Free (RoHS compatible), and free of Bromine (Br) and Antimony (Sb) based flame retardants (Br or Sb do not exceed 0.1% by weight in homogeneous material)

(3) MSL, Peak Temp. - The Moisture Sensitivity Level rating according to the JEDEC industry standard classifications, and peak solder temperature.

(4) There may be additional marking, which relates to the logo, the lot trace code information, or the environmental category on the device.

(5) Multiple Device Markings will be inside parentheses. Only one Device Marking contained in parentheses and separated by a "~" will appear on a device. If a line is indented then it is a continuation of the previous line and the two combined represent the entire Device Marking for that device.

<sup>(6)</sup> Lead/Ball Finish - Orderable Devices may have multiple material finish options. Finish options are separated by a vertical ruled line. Lead/Ball Finish values may wrap to two lines if the finish value exceeds the maximum column width.

**Important Information and Disclaimer:** The information provided on this page represents TI's knowledge and belief as of the date that it is provided. TI bases its knowledge and belief on information provided by third parties, and makes no representation or warranty as to the accuracy of such information. Efforts are underway to better integrate information from third parties. TI has taken and continues to take reasonable steps to provide representative and accurate information but may not have conducted destructive testing or chemical analysis on incoming materials and chemicals. TI and TI suppliers consider certain information to be proprietary, and thus CAS numbers and other limited information may not be available for release.

In no event shall TI's liability arising out of such information exceed the total purchase price of the TI part(s) at issue in this document sold by TI to Customer on an annual basis.

## TAPE AND REEL INFORMATION



### QUADRANT ASSIGNMENTS FOR PIN 1 ORIENTATION IN TAPE



\*All dimensions are nominal

Device	Package Type	Package Drawing	Pins	SPQ	Reel Diameter (mm)	Reel Width W1 (mm)	A0 (mm)	B0 (mm)	K0 (mm)	P1 (mm)	W (mm)	Pin1 Quadrant
LMH0344GR/NOPB	csBGA	NYA	25	1000	178.0	12.4	3.3	3.3	1.6	8.0	12.0	Q1
LMH0344GRE/NOPB	csBGA	NYA	25	250	178.0	12.4	3.3	3.3	1.6	8.0	12.0	Q1
LMH0344SQ/NOPB	WQFN	RUM	16	1000	178.0	12.4	4.3	4.3	1.3	8.0	12.0	Q1
LMH0344SQE/NOPB	WQFN	RUM	16	250	178.0	12.4	4.3	4.3	1.3	8.0	12.0	Q1
LMH0344SQX/NOPB	WQFN	RUM	16	4500	330.0	12.4	4.3	4.3	1.3	8.0	12.0	Q1

**TAPE AND REEL BOX DIMENSIONS**

\*All dimensions are nominal

Device	Package Type	Package Drawing	Pins	SPQ	Length (mm)	Width (mm)	Height (mm)
LMH0344GR/NOPB	csBGA	NYA	25	1000	210.0	185.0	35.0
LMH0344GRE/NOPB	csBGA	NYA	25	250	210.0	185.0	35.0
LMH0344SQ/NOPB	WQFN	RUM	16	1000	210.0	185.0	35.0
LMH0344SQE/NOPB	WQFN	RUM	16	250	210.0	185.0	35.0
LMH0344SQX/NOPB	WQFN	RUM	16	4500	367.0	367.0	35.0

NYA0025A

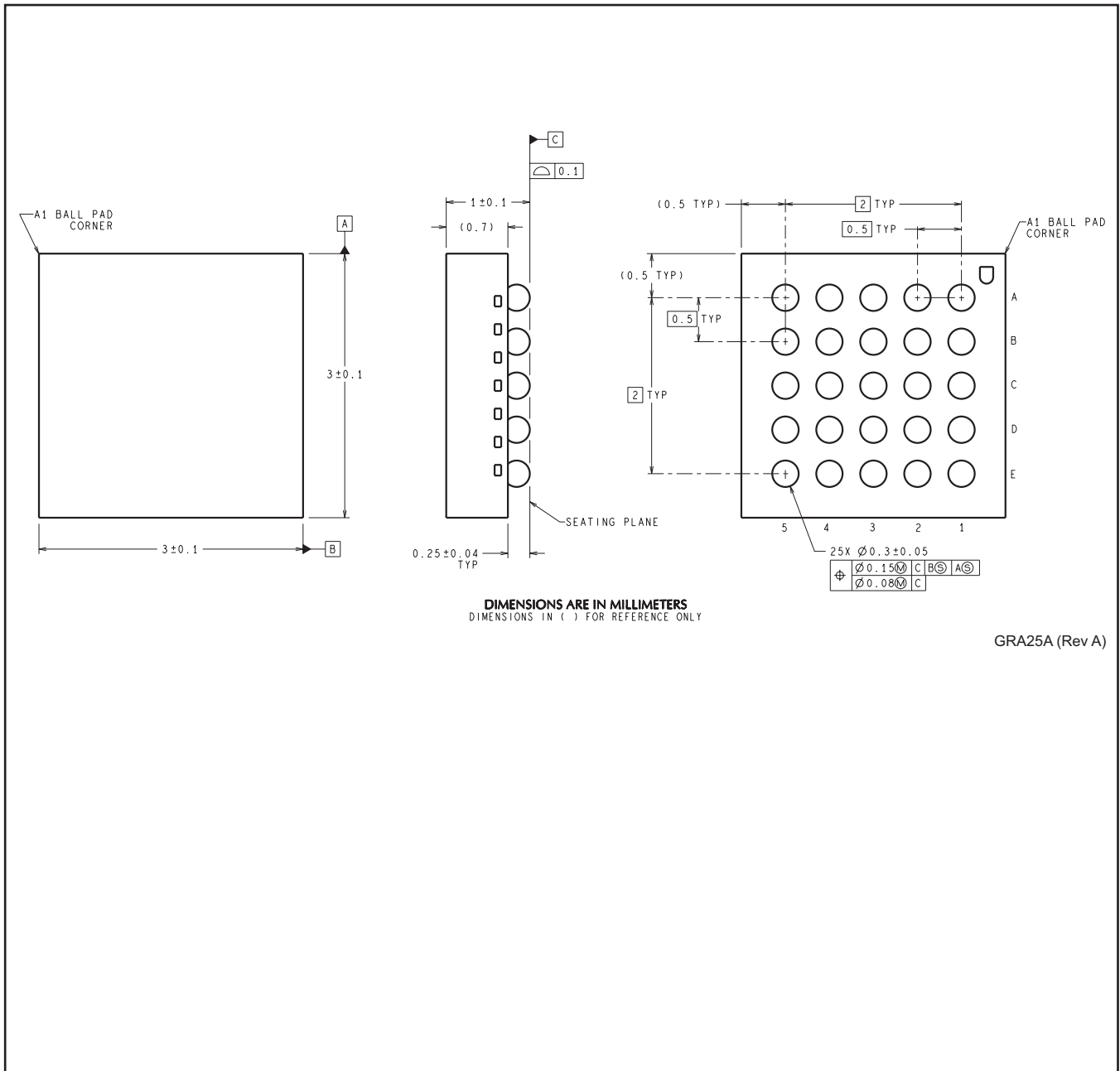

GRA25A (Rev A)



## IMPORTANT NOTICE

Texas Instruments Incorporated (TI) reserves the right to make corrections, enhancements, improvements and other changes to its semiconductor products and services per JESD46, latest issue, and to discontinue any product or service per JESD48, latest issue. Buyers should obtain the latest relevant information before placing orders and should verify that such information is current and complete.

TI's published terms of sale for semiconductor products (<http://www.ti.com/sc/docs/stdterms.htm>) apply to the sale of packaged integrated circuit products that TI has qualified and released to market. Additional terms may apply to the use or sale of other types of TI products and services.

Reproduction of significant portions of TI information in TI data sheets is permissible only if reproduction is without alteration and is accompanied by all associated warranties, conditions, limitations, and notices. TI is not responsible or liable for such reproduced documentation. Information of third parties may be subject to additional restrictions. Resale of TI products or services with statements different from or beyond the parameters stated by TI for that product or service voids all express and any implied warranties for the associated TI product or service and is an unfair and deceptive business practice. TI is not responsible or liable for any such statements.

Buyers and others who are developing systems that incorporate TI products (collectively, "Designers") understand and agree that Designers remain responsible for using their independent analysis, evaluation and judgment in designing their applications and that Designers have full and exclusive responsibility to assure the safety of Designers' applications and compliance of their applications (and of all TI products used in or for Designers' applications) with all applicable regulations, laws and other applicable requirements. Designer represents that, with respect to their applications, Designer has all the necessary expertise to create and implement safeguards that (1) anticipate dangerous consequences of failures, (2) monitor failures and their consequences, and (3) lessen the likelihood of failures that might cause harm and take appropriate actions. Designer agrees that prior to using or distributing any applications that include TI products, Designer will thoroughly test such applications and the functionality of such TI products as used in such applications.

TI's provision of technical, application or other design advice, quality characterization, reliability data or other services or information, including, but not limited to, reference designs and materials relating to evaluation modules, (collectively, "TI Resources") are intended to assist designers who are developing applications that incorporate TI products; by downloading, accessing or using TI Resources in any way, Designer (individually or, if Designer is acting on behalf of a company, Designer's company) agrees to use any particular TI Resource solely for this purpose and subject to the terms of this Notice.

TI's provision of TI Resources does not expand or otherwise alter TI's applicable published warranties or warranty disclaimers for TI products, and no additional obligations or liabilities arise from TI providing such TI Resources. TI reserves the right to make corrections, enhancements, improvements and other changes to its TI Resources. TI has not conducted any testing other than that specifically described in the published documentation for a particular TI Resource.

Designer is authorized to use, copy and modify any individual TI Resource only in connection with the development of applications that include the TI product(s) identified in such TI Resource. NO OTHER LICENSE, EXPRESS OR IMPLIED, BY ESTOPPEL OR OTHERWISE TO ANY OTHER TI INTELLECTUAL PROPERTY RIGHT, AND NO LICENSE TO ANY TECHNOLOGY OR INTELLECTUAL PROPERTY RIGHT OF TI OR ANY THIRD PARTY IS GRANTED HEREIN, including but not limited to any patent right, copyright, mask work right, or other intellectual property right relating to any combination, machine, or process in which TI products or services are used. Information regarding or referencing third-party products or services does not constitute a license to use such products or services, or a warranty or endorsement thereof. Use of TI Resources may require a license from a third party under the patents or other intellectual property of the third party, or a license from TI under the patents or other intellectual property of TI.

TI RESOURCES ARE PROVIDED "AS IS" AND WITH ALL FAULTS. TI DISCLAIMS ALL OTHER WARRANTIES OR REPRESENTATIONS, EXPRESS OR IMPLIED, REGARDING RESOURCES OR USE THEREOF, INCLUDING BUT NOT LIMITED TO ACCURACY OR COMPLETENESS, TITLE, ANY EPIDEMIC FAILURE WARRANTY AND ANY IMPLIED WARRANTIES OF MERCHANTABILITY, FITNESS FOR A PARTICULAR PURPOSE, AND NON-INFRINGEMENT OF ANY THIRD PARTY INTELLECTUAL PROPERTY RIGHTS. TI SHALL NOT BE LIABLE FOR AND SHALL NOT DEFEND OR INDEMNIFY DESIGNER AGAINST ANY CLAIM, INCLUDING BUT NOT LIMITED TO ANY INFRINGEMENT CLAIM THAT RELATES TO OR IS BASED ON ANY COMBINATION OF PRODUCTS EVEN IF DESCRIBED IN TI RESOURCES OR OTHERWISE. IN NO EVENT SHALL TI BE LIABLE FOR ANY ACTUAL, DIRECT, SPECIAL, COLLATERAL, INDIRECT, PUNITIVE, INCIDENTAL, CONSEQUENTIAL OR EXEMPLARY DAMAGES IN CONNECTION WITH OR ARISING OUT OF TI RESOURCES OR USE THEREOF, AND REGARDLESS OF WHETHER TI HAS BEEN ADVISED OF THE POSSIBILITY OF SUCH DAMAGES.

Unless TI has explicitly designated an individual product as meeting the requirements of a particular industry standard (e.g., ISO/TS 16949 and ISO 26262), TI is not responsible for any failure to meet such industry standard requirements.

Where TI specifically promotes products as facilitating functional safety or as compliant with industry functional safety standards, such products are intended to help enable customers to design and create their own applications that meet applicable functional safety standards and requirements. Using products in an application does not by itself establish any safety features in the application. Designers must ensure compliance with safety-related requirements and standards applicable to their applications. Designer may not use any TI products in life-critical medical equipment unless authorized officers of the parties have executed a special contract specifically governing such use. Life-critical medical equipment is medical equipment where failure of such equipment would cause serious bodily injury or death (e.g., life support, pacemakers, defibrillators, heart pumps, neurostimulators, and implantables). Such equipment includes, without limitation, all medical devices identified by the U.S. Food and Drug Administration as Class III devices and equivalent classifications outside the U.S.

TI may expressly designate certain products as completing a particular qualification (e.g., Q100, Military Grade, or Enhanced Product). Designers agree that it has the necessary expertise to select the product with the appropriate qualification designation for their applications and that proper product selection is at Designers' own risk. Designers are solely responsible for compliance with all legal and regulatory requirements in connection with such selection.

Designer will fully indemnify TI and its representatives against any damages, costs, losses, and/or liabilities arising out of Designer's non-compliance with the terms and provisions of this Notice.

## Looking for pricing, stock, or lifecycle information?

Click below to explore more details on WIN SOURCE:

 [View SD344EVK](#) on WIN SOURCE

 [Texas Instruments](#) Information

## Optimize Your Supply Chain with WIN SOURCE Solutions

-  Global Sourcing Solution
-  Obsolete Management
-  Cost Control Management
-  Shortage Management
-  Alternative Solution
-  Excess Inventory Management