



**THE DATASHEET OF  
LM96551SQE/NOPB**



## LM96551 Ultrasound Transmit Pulser

Check for Samples: [LM96551](#)

### FEATURES

- 8-Channel High-Voltage CMOS Pulse Generator
- Output Pulses with  $\pm 50\text{V}$  and 2A Peak Current
- Active Damper with Built-In Blocking Diodes
- Built-In Floating Supply Voltages for Output Stage
- Up to 15 MHz Operating Frequency
- Matched Delays for Rising and Falling Edges
- Low Second Harmonic Distortion Allows and Improves Harmonic Imaging
- Continuous-Wave (CW) Operation Down to  $\pm 3.3\text{V}$
- Low Phase Noise Enables Doppler Measurements
  - $-145\text{ dBc/Hz}$  Phase Noise at 10 MHz (1 kHz offset)
- Output State Over-Temperature Protection
- Blocking Diodes for Direct Interface to Transducer
- 2.5V to 5.0V CMOS Logic Interface
- Low-Power Consumption per Channel
- Over Temperature Protection

### KEY SPECIFICATIONS

- Output voltage  $\pm 50\text{ V}$
- Output peak current  $\pm 2.0\text{ A}$
- Output pulse rate Up to 15 MHz
- Rise/fall delay matching (max)  $< 3.7\text{ ns}$
- Pulser HD2 (5 MHz)  $-40\text{ dB}$
- Operating Temp. 0 to  $+70\text{ }^\circ\text{C}$

### APPLICATIONS

- Ultrasound Imaging

### DESCRIPTION

The LM96551 is an eight-channel monolithic high-voltage, high-speed pulse generator for multi-channel medical ultrasound applications. It is well-suited for use with Texas Instrument's LM965XX series chipset which offers a complete medical ultrasound solution targeted towards low-power, portable systems.

The LM96551 contains eight high-voltage pulsers with integrated diodes generating  $\pm 50\text{V}$  bipolar pulses with peak currents of up to 2A and pulse rates of up to 15 MHz. Advanced features include low-jitter and low-phase-noise output pulses ideal for continuous-wave (CW) modes of operation. Active clamp circuitry is integrated for ensuring low harmonic distortion of the output signal waveform.

The LM96551 also features a low-power operation mode and over-temperature protection (OTP) which are enabled by on-chip temperature sensing and power-down logic.



Please be aware that an important notice concerning availability, standard warranty, and use in critical applications of Texas Instruments semiconductor products and disclaimers thereto appears at the end of this data sheet.

All trademarks are the property of their respective owners.

Block Diagram

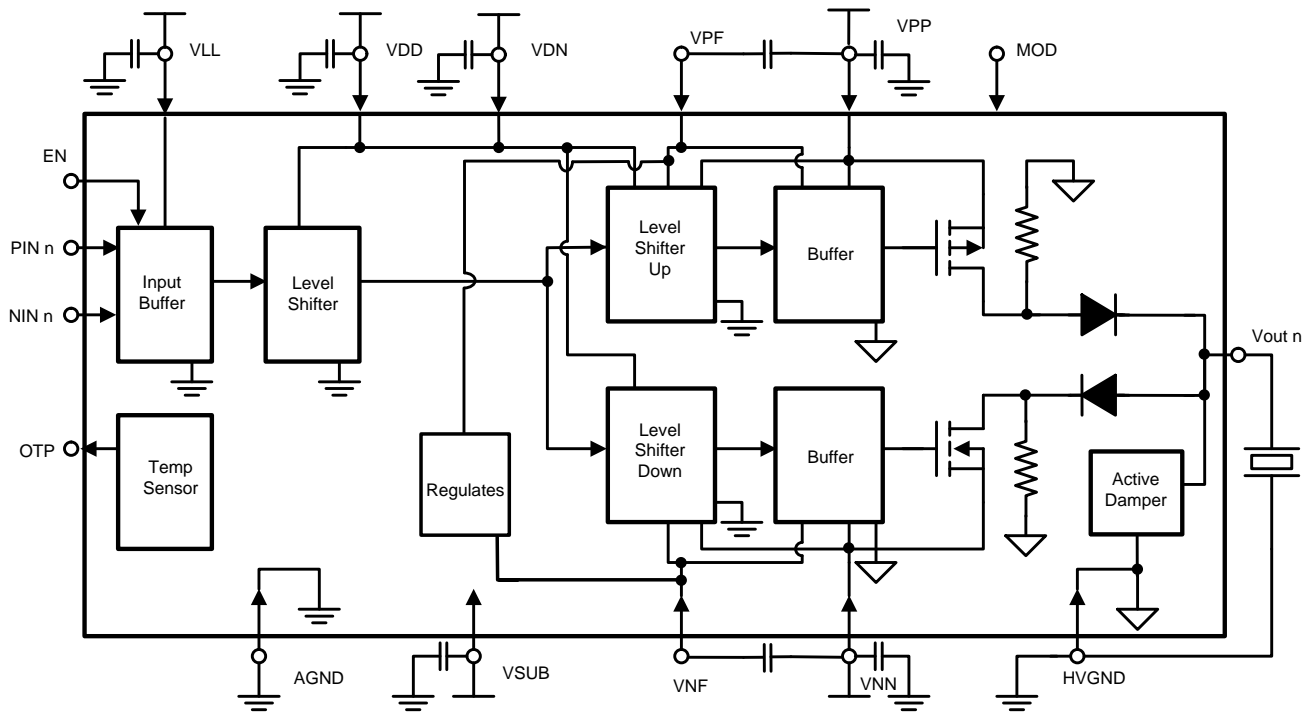

Typical Application

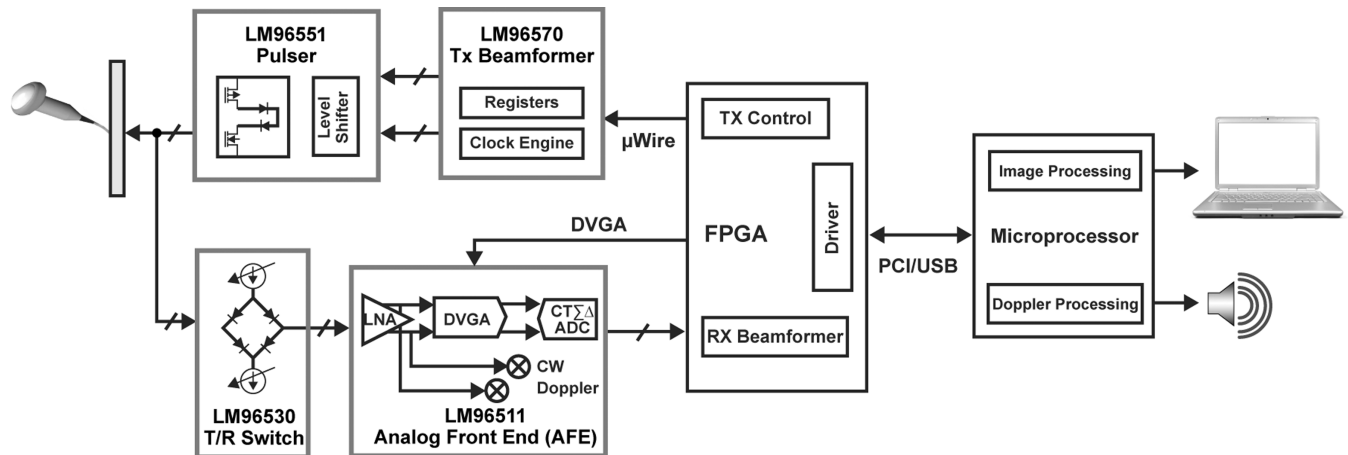
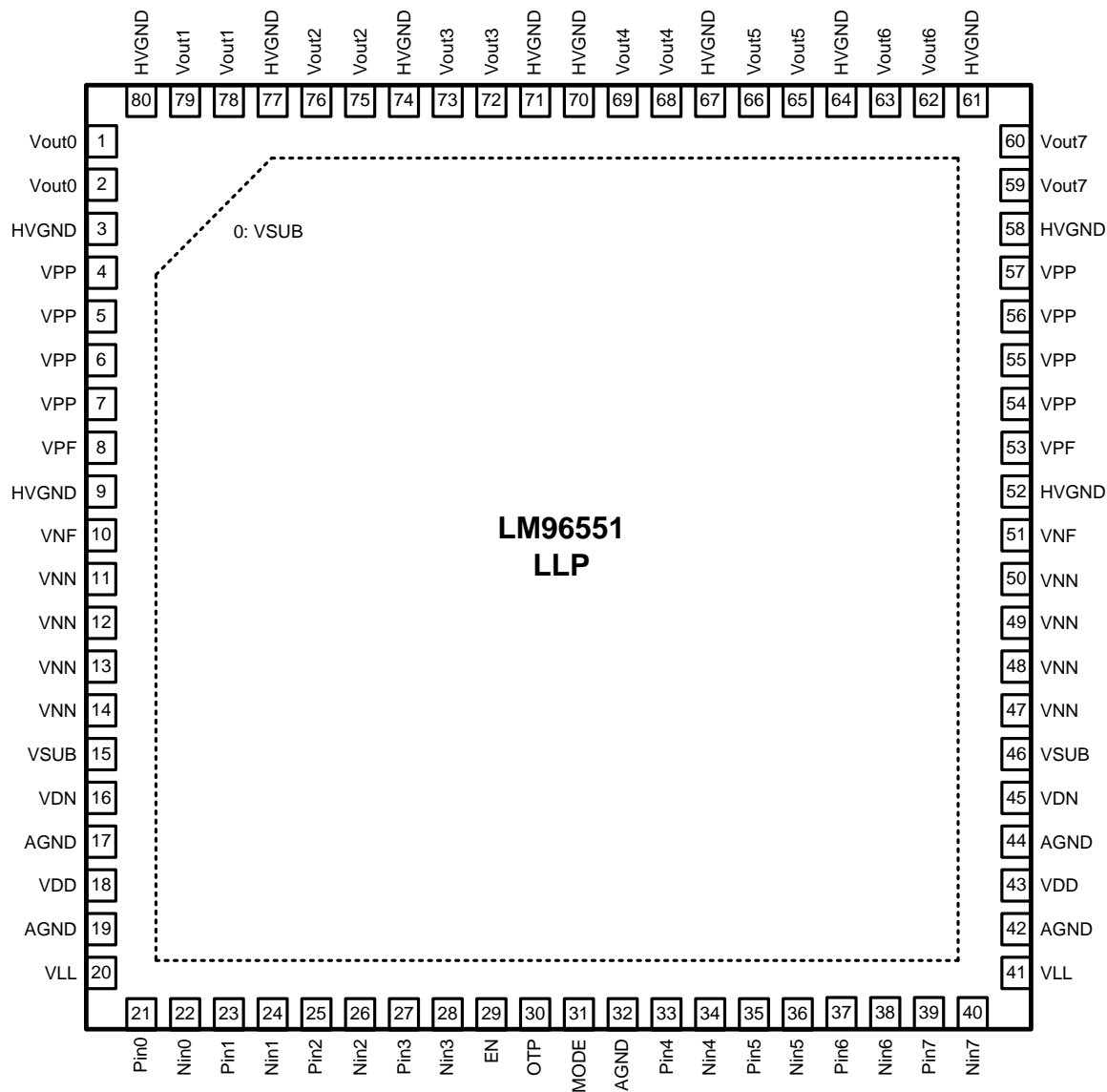

Figure 1. 8-Channel Transmit/Receive Chipset

Pin Diagram



**Figure 2. WQFN Package  
See Package Number NKF0080A**

**PIN DESCRIPTIONS**

| Pin No.                                      | Name              | Type   | Function and Connection  |
|--|-------------------|--------|--|
| 21, 23, 25, 27, 33, 35, 37, 39               | PIN<br>n=0...7    | Input  | Logic control positive output channel P<br>1 = ON<br>0 = OFF   |
| 22, 24, 26, 28, 34, 36, 38, 40               | NIN<br>n=0...7    | Input  | Logic control negative output channel N<br>1 = ON<br>0 = OFF   |
| 59, 60                                       | V <sub>OUT7</sub> | Output | High voltage output of channels 0 to 7   |
| 62, 63                                       | V <sub>OUT6</sub> |        |  |
| 65, 66                                       | V <sub>OUT5</sub> |        |  |
| 68, 69                                       | V <sub>OUT4</sub> |        |  |
| 72, 73                                       | V <sub>OUT3</sub> |        |  |
| 75, 76                                       | V <sub>OUT2</sub> |        |  |
| 78, 79                                       | V <sub>OUT1</sub> |        |  |
| 1, 2   | V <sub>OUT0</sub> |        |  |
| 29   | EN                | Input  | Chip power enable<br>1 = ON<br>0 = OFF   |
| 31   | MODE              | Input  | Output current mode control<br>1 = Max Current<br>0 = Low Current  |
| 30   | OTP               | Output | Over-temperature indicating IC temp > 125°C<br>0 = Over-temperature<br>1 = Normal temperature<br>This pin is open-drain.     |
| 4, 5, 6, 7, 54, 55, 56, 57                   | VPP               | Power  | Positive high voltage power supply (+3.3V to +50V)   |
| 11, 12, 13, 14, 47, 48, 49, 50               | VNN               | Power  | Negative high voltage power supply (-3.3V to -50V)   |
| 8, 53  | VPF               | Power  | Positive internal floating power supply (VPP -10V)   |
| 10, 51                                       | VNF               | Power  | Negative internal floating power supply (VNN +10V)   |
| 18, 43                                       | VDD               | Power  | Positive level-shifter supply voltage (+10V)   |
| 16, 45                                       | VDN               | Power  | Negative level-shifter supply voltage (-10V)   |
| 20, 41                                       | VLL               | Power  | Logic supply voltage. Hi voltage reference input (+2.5 to +5V)   |
| 0, 15, 46                                    | VSUB              | Power  | All VSUB pins must be connected to most negative potential of the IC.<br>NOTE: The exposed thermal pad is connected to VSUB. |
| 3, 9, 52, 58, 61, 64, 67, 70, 71, 74, 77, 80 | HVGND             | Ground | High voltage reference potential (0V)  |
| 17, 19, 32, 42, 44                           | AGND              | Ground | Analog and Logic voltage reference input, logic ground (0V)  |



These devices have limited built-in ESD protection. The leads should be shorted together or the device placed in conductive foam during storage or handling to prevent electrostatic damage to the MOS gates.

### Absolute Maximum Ratings <sup>(1)(2)</sup>

|   |                    |
|---|--------------------|
| Maximum Junction Temperature (T <sub>JMAX</sub> ) | +150°C             |
| Storage Temperature Range                         | -40°C to +125°C    |
| Supply Voltage (VDD)                              | -0.3V to +12V      |
| Supply Voltage (VDN)                              | +0.3V and -12V     |
| Supply Voltage (VPP)                              | -0.3V and +55V     |
| Supply Voltage (VNN)                              | +0.3V and -55V     |
| Supply Voltage (VSUB)                             | -65V               |
| IO Supply Voltage (VLL)                           | -0.3V to +5.5V     |
| Voltage at Logic Inputs                           | -0.3V to VLL +0.3V |

- (1) Absolute Maximum Ratings are limits beyond which damage to the device may occur. Operating Ratings are conditions under which operation of the device is specified to be functional, but do not specify specific performance limits. For specifications and test conditions, see the Electrical Characteristics.
- (2) If Military/Aerospace specified devices are required, please contact the Texas Instruments Sales Office/ Distributors for availability and specifications.

### Operating Ratings

|   |                              |      |
|---|------------------------------|------|
| Operation Junction Temperature                | 0°C to +70°C                 |      |
| VPP, -VNN; High-voltage supply                | +3.3V to +50V                |      |
| VDD, -VDN; Level-shift supply                 | +9V to 11V                   |      |
| VLL, Logic Supply                             | +2.4V to +5.3V               |      |
| VSUB, Substrate bias supply                   | must be most negative supply |      |
| Package Thermal Resistance (θ <sub>JA</sub> ) | 19.7 °C/W                    |      |
| ESD Tolerance                                 | Human Body Model             | 2KV  |
|   | Machine Model                | 150V |
|   | Charge Device Model          | 750V |

## Analog Characteristics

Unless otherwise stated, the following conditions apply

VLL = +3.3V, VPP = -VNN = 50V, VSUB = -55V, VDD = -VDN = 10V, RL = 2KΩ, TA = 25°C, Fin=5MHz, Mode = LO, EN = HI.

| Symbol              | Parameter                   | Conditions                 | Min   | Typ | Max   | Units |    |
|---------------------|-----------------------------|----------------------------|-------|-----|-------|-------|----|
| F <sub>OUT</sub>    | Output Frequency Range      | RL = 100Ω                  | 1     |     | 15    | MHz   |    |
|                     | Output Voltage Range        |                            | -48.5 |     | +48.5 | V     |    |
|                     | Output Current              | 2% Duty Cycle              |       | 2   |       | A     |    |
| Output Current      | 100% Duty Cycle,<br>Mode=HI |                            | 0.6   |     |       |       |    |
| HD2                 | Second harmonic distortion  | RL = 100Ω, CL = 330pF      |       | -40 |       | dBc   |    |
| R <sub>ON</sub>     | Output ON Resistance        | 100 mA                     |       | 7   | 11    | Ω     |    |
|                     | Output clamp                | Positive or Negative pulse |       | 2   |       | A     |    |
|                     | Power Supply Current        | Pin = Nin = LO             | VPP   |     | 3.2   | 7     | mA |
|                     |                             |                            | VNN   |     | 3.4   | 8     |    |
|                     |                             |                            | VDD   |     | 12    | 18    |    |
|                     |                             |                            | VDN   |     | 8     | 13    |    |
|                     |                             |                            | VLL   |     | 25    | 50    | μA |
|                     |                             |                            | VSUB  |     | 0.7   | 6     | mA |
|                     |                             | En = LO                    | VPP   |     | 3.2   | 7     | mA |
|                     |                             |                            | VNN   |     | 3.4   | 8     |    |
|                     |                             |                            | VDD   |     | 4     | 7     |    |
|                     |                             |                            | VDN   |     | 3     | 6.5   |    |
|                     |                             |                            | VLL   |     | 25    | 50    | μA |
|                     |                             |                            | VSUB  |     | 0.7   | 6     | mA |
| OTP                 | Over Temperature Protection |                            |       | 125 |       | °C    |    |
| σ <sub>OTP</sub>    | OTP sigma                   |                            |       | 3.0 |       | °C    |    |
| H <sub>sysOTP</sub> | OTP hysteresis              |                            |       | 5.5 |       | °C    |    |

## AC and Timing Characteristics

Unless otherwise stated, the following conditions apply

VLL = +3.3V, VDD = -VDN = 10V, VSUB = -55V, VPP = -VNN = 50V, RL = 100Ω, CL = 330pF, Fin=5MHz, TA = 25°C. Mode = LO, EN = HI.

| Symbol                            | Parameter                 | Conditions            | Min | Typ | Max | Unit |
|-----------------------------------|---------------------------|-----------------------|-----|-----|-----|------|
| t <sub>r</sub>                    | Output rise time          |                       |     | 19  | 29  | ns   |
| t <sub>f</sub>                    | Output fall time          |                       |     | 19  | 29  |      |
| t <sub>E</sub>                    | Enable time               |                       |     | 1   |     | μs   |
| t <sub>dr</sub>                   | Delay time on inputs rise |                       |     | 32  | 39  | ns   |
| t <sub>df</sub>                   | Delay time on inputs fall |                       |     | 32  | 39  |      |
| t <sub>dr</sub> - t <sub>df</sub> | Delay time mismatch       | P-to-N <sup>(1)</sup> |     |     | 3.7 |      |
| t <sub>dm</sub>                   | Delay on mode change      |                       |     | 1   |     | μs   |

(1) The delay time mismatch can be adjust to be less than 0.8ns with the LM96570 duty cycle control function.

## DC Characteristics

Unless otherwise stated, the following conditions apply.

VLL = +3.3V, VDD = -VDN = 10V, VSUB = -55V, VPP = -VNN = 50V, TA = 25°C,

| Symbol          | Parameter                 | Conditions | Min | Typ | Max | Unit |
|-----------------|---------------------------|------------|-----|-----|-----|------|
| V <sub>IL</sub> | Low Input "LO" threshold  |            |     |     | 1   | V    |
| V <sub>IH</sub> | High Input "HI" threshold |            | 2.3 |     |     | V    |
| I <sub>IN</sub> | input current             |            |     | 1   |     | μA   |

## Overview

The LM96551 pulser provides an 8-channel transmit side solution for medical ultrasound applications suitable for integration into multi-channel (128/256 channel) systems. Its flexible, integrated ±50V pulser architecture enables low-power designs targeting portable systems. A complete system can be designed using Texas Instrument's companion LM965XX chipset.

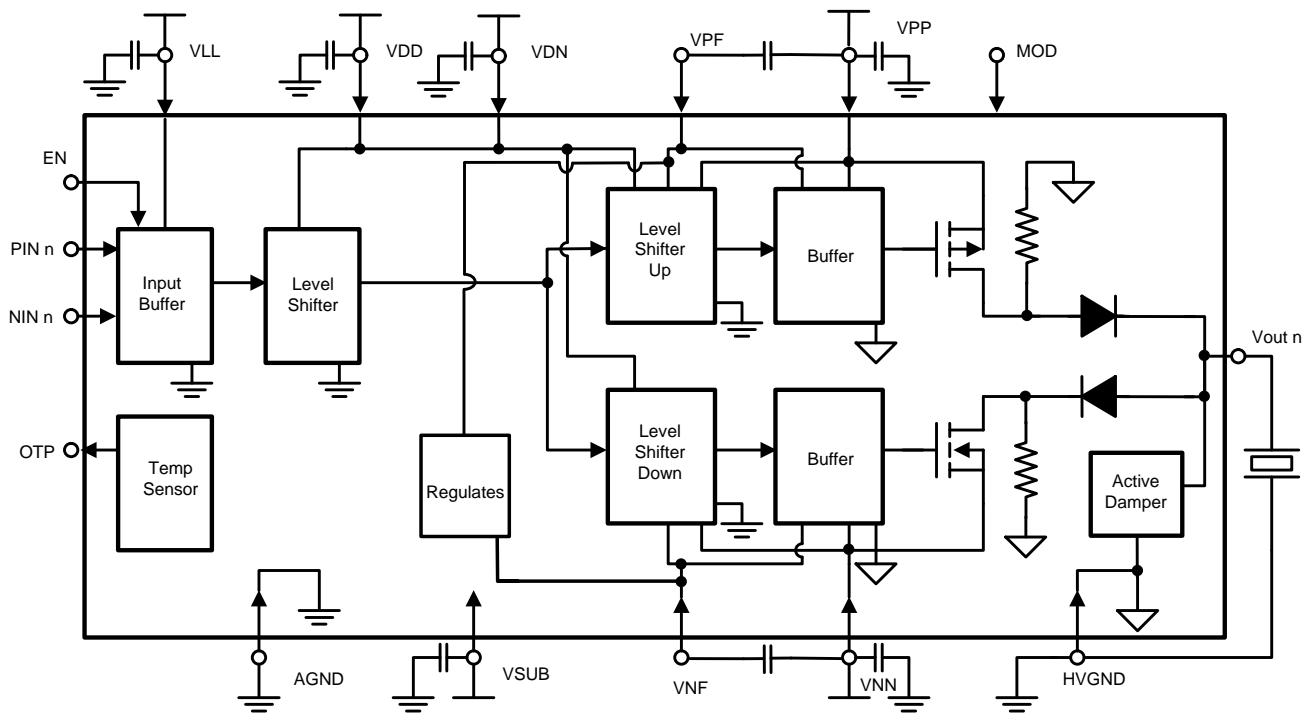

Figure 3. Block Diagram of High-Voltage Pulser Channel

A functional block diagram of the LM96551 is shown in Figure 3. It has an input buffer at its CMOS logic interface, which is powered by VLL (2.5 to 5.0V). When EN=HI, driving a channel's inputs (PIN n or NIN n) HI will result in a positive or negative pulse at the channel's output pin (V<sub>OUT</sub> n), respectively. The output pins V<sub>OUT</sub> are pulled to either the positive or negative supplies, VPP or VNN by power MOSFETs.

When PIN and NIN are both LO, Vout is actively clamped to GNDHI at 0V. This clamping reduces harmonic distortions compared to competing architectures that use bleeding resistors for implementing the return to zero of the output. **The user must avoid the condition in which PIN and NIN are both HI simultaneously, as this will damage the output stage!**

The impedance of the output stage can be controlled via the Mode-pin. When the Mode = HI as shown, only one output transistor pair drives the output resulting in a peak current of 600 mA at VPP = -VNN = 50V. When Mode=LO, a peak-current of 2A is achievable resulting in faster transients at the output. However, faster output transients can lead to significant overshoot of the output signal. This can be avoided using the lower drive current option.

Continuous-wave (CW) applications are supported for low power consumption down to  $V_{PP} = -V_{NN} = 3.3V$  with Mode =HI.

Internally, the CMOS logic input signals are level shifted to  $V_{DD} = 10V$  and  $V_{DN} = -10V$  for pulse transmission. The outputs of the level shifter drive the high-voltage P and N drivers that control the output power MOSFETs, which are supplied from the positive and negative rails  $V_{PP}$  and  $V_{NN}$ , respectively. The high-voltage rails are designed for a maximum of 50V; however, they can be operated down to 3.3V. The necessary gate-overdrive voltage levels for the output drivers are internally generated from the high-voltage rails.

Over-Temperature Protection (OTP) is implemented by continuously monitoring the on-chip temperature. The OTP output (open drain) pin goes LO when the chip temperature exceeds a critical level. Prior to this event, the user must ensure that the chip is powered down before fatal damage occurs. In addition to a primary software controlled safety shutdown, the OTP pin can be also be hard-wired to the EN pin as a secondary safety measure.

## Timing Diagrams

### RISE AND FALL TIME

The timing diagram shown in [Figure 4](#) defines the rise and fall times  $t_r$  and  $t_f$ .

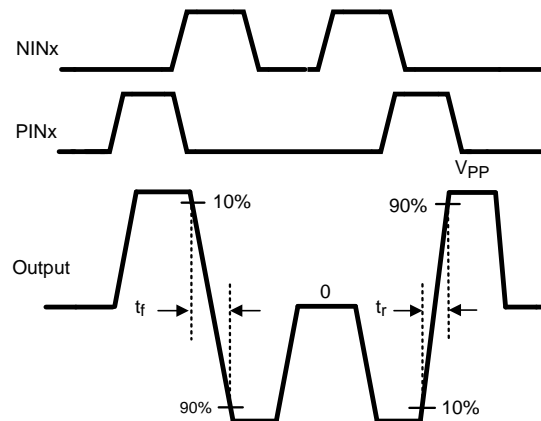

**Figure 4. Timing Diagram Defining Rise and Fall Times  $t_r$  and  $t_f$ , respectively**

### INPUT TO OUTPUT DELAY

The timing diagram shown in [Figure 5](#) defines the delays between the input and output signals.

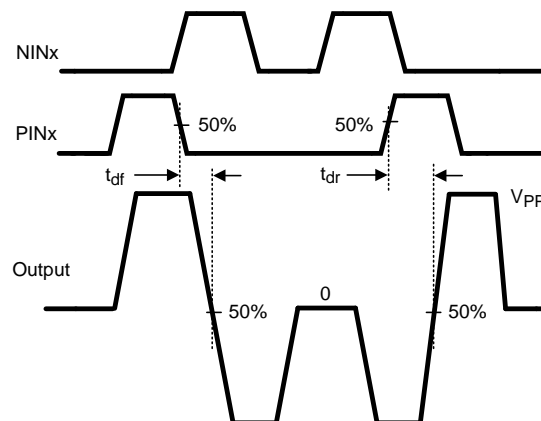

**Figure 5. Timing Diagram Defining Input-to-Output Delays Times**

### Typical Performance Characteristics

Unless otherwise stated, the following conditions apply

VLL = +3.3V, VDD = -VDN = 10V, VSUB = -55V, VPP = -VNN = 50V, RL = 100Ω, CL = 330pF, Fin=5MHz, TA = 25°C. Mode = LO, EN = HI

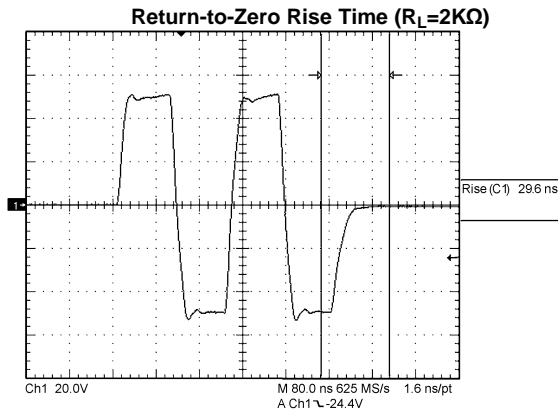

Figure 6.

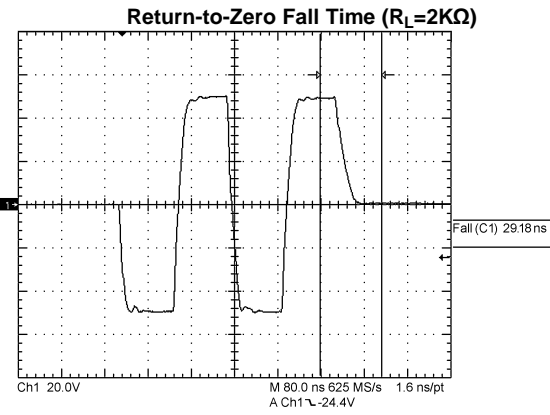

Figure 7.

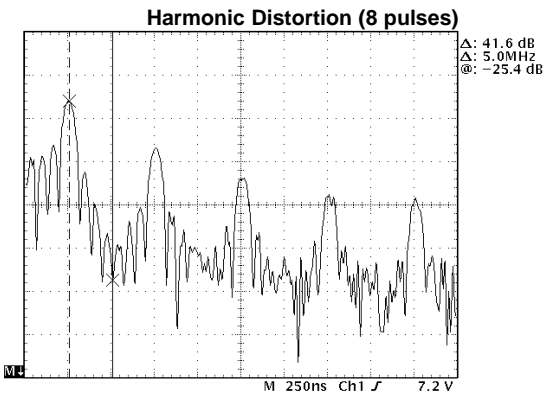

Figure 8.

### Differential Input vs. Pulser Output Phase Noise<sup>(1)</sup>

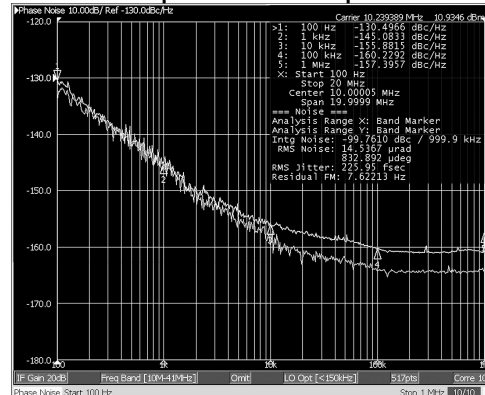

Figure 9.

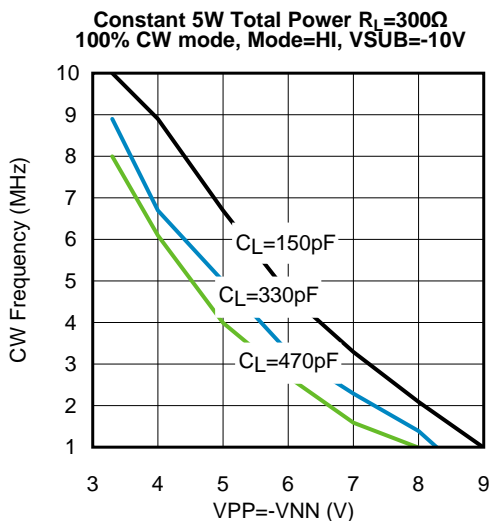

Figure 10.

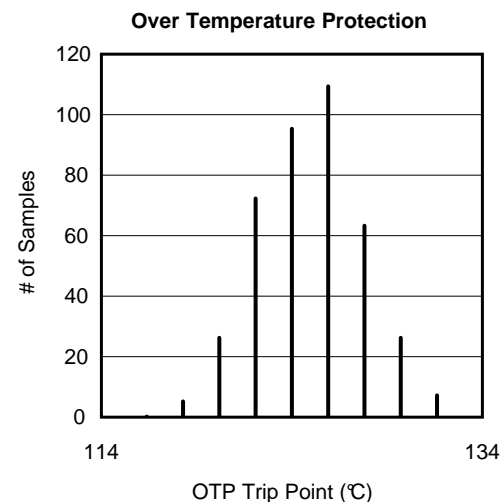

Figure 11.

(1) 10.24 MHz Differential Input signal from LMK04800 Evaluation board with 122.88 MHz Crystek CVHD-950 VCXO clock source. The LMK04800 clock output channel was configured with a divide value of 12 and LVCMOS outputs with opposite polarity.

## FUNCTIONAL DESCRIPTION

Note that the case, PINn = NNn = HI is not allowed as it will damage the output transistors.

| Logic inputs |      |      | Output             |
|--------------|------|------|--------------------|
| EN           | PINn | NINn | Voutn              |
| 1            | 0    | 0    | 0V                 |
| 1            | 1    | 0    | VPP - 0.7V         |
| 1            | 0    | 1    | VNN + 0.7V         |
| 1            | 1    | 1    | <b>not allowed</b> |
| 0            | X    | X    | 0V                 |

## APPLICATIONS INFORMATION

### POWER-UP AND POWER-DOWN SEQUENCES

VSUB must always be the most negative supply, i.e., it must be equal to or more negative than the most negative supply, VNN or VDN.

Power UP Sequence:

1. Turn ON VSUB, hold EN pin LO
2. Turn On VLL
3. Turn ON VDD, VDN, VPP, and VNN

Power DOWN Sequence:

1. Turn OFF VDD, VDN, VPP & VNN
2. Turn OFF VLL
3. Turn OFF VSUB

---

**REVISION HISTORY**

| <b>Changes from Revision A (May 2013) to Revision B</b>    | <b>Page</b>        |
|--|--------------------|
| • Changed layout of National Data Sheet to TI format ..... | <a href="#">10</a> |

---

**PACKAGING INFORMATION**

| Orderable Device | Status<br>(1) | Package Type | Package<br>Drawing | Pins | Package<br>Qty | Eco Plan<br>(2)            | Lead/Ball Finish<br>(6) | MSL Peak Temp<br>(3) | Op Temp (°C) | Device Marking<br>(4/5) | Samples |
|------------------|---------------|--------------|--------------------|------|----------------|----------------------------|-------------------------|----------------------|--------------|-------------------------|---------|
| LM96551SQE/NOPB  | LIFEBUY       | WQFN         | NKF                | 80   | 250            | Green (RoHS<br>& no Sb/Br) | CU SN   Call TI         | Level-3-260C-168 HR  |              | LM96551SQ               |         |

(1) The marketing status values are defined as follows:

**ACTIVE:** Product device recommended for new designs.

**LIFEBUY:** TI has announced that the device will be discontinued, and a lifetime-buy period is in effect.

**NRND:** Not recommended for new designs. Device is in production to support existing customers, but TI does not recommend using this part in a new design.

**PREVIEW:** Device has been announced but is not in production. Samples may or may not be available.

**OBSELETE:** TI has discontinued the production of the device.

(2) Eco Plan - The planned eco-friendly classification: Pb-Free (RoHS), Pb-Free (RoHS Exempt), or Green (RoHS & no Sb/Br) - please check <http://www.ti.com/productcontent> for the latest availability information and additional product content details.

**TBD:** The Pb-Free/Green conversion plan has not been defined.

**Pb-Free (RoHS):** TI's terms "Lead-Free" or "Pb-Free" mean semiconductor products that are compatible with the current RoHS requirements for all 6 substances, including the requirement that lead not exceed 0.1% by weight in homogeneous materials. Where designed to be soldered at high temperatures, TI Pb-Free products are suitable for use in specified lead-free processes.

**Pb-Free (RoHS Exempt):** This component has a RoHS exemption for either 1) lead-based flip-chip solder bumps used between the die and package, or 2) lead-based die adhesive used between the die and leadframe. The component is otherwise considered Pb-Free (RoHS compatible) as defined above.

**Green (RoHS & no Sb/Br):** TI defines "Green" to mean Pb-Free (RoHS compatible), and free of Bromine (Br) and Antimony (Sb) based flame retardants (Br or Sb do not exceed 0.1% by weight in homogeneous material)

(3) MSL, Peak Temp. - The Moisture Sensitivity Level rating according to the JEDEC industry standard classifications, and peak solder temperature.

(4) There may be additional marking, which relates to the logo, the lot trace code information, or the environmental category on the device.

(5) Multiple Device Markings will be inside parentheses. Only one Device Marking contained in parentheses and separated by a "~" will appear on a device. If a line is indented then it is a continuation of the previous line and the two combined represent the entire Device Marking for that device.

(6) Lead/Ball Finish - Orderable Devices may have multiple material finish options. Finish options are separated by a vertical ruled line. Lead/Ball Finish values may wrap to two lines if the finish value exceeds the maximum column width.

**Important Information and Disclaimer:**The information provided on this page represents TI's knowledge and belief as of the date that it is provided. TI bases its knowledge and belief on information provided by third parties, and makes no representation or warranty as to the accuracy of such information. Efforts are underway to better integrate information from third parties. TI has taken and continues to take reasonable steps to provide representative and accurate information but may not have conducted destructive testing or chemical analysis on incoming materials and chemicals. TI and TI suppliers consider certain information to be proprietary, and thus CAS numbers and other limited information may not be available for release.

In no event shall TI's liability arising out of such information exceed the total purchase price of the TI part(s) at issue in this document sold by TI to Customer on an annual basis.

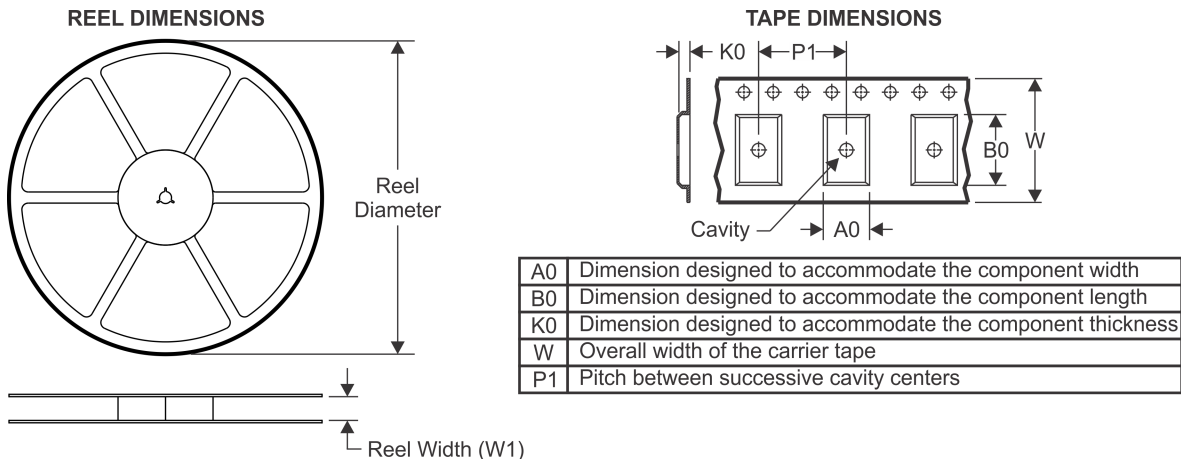

**TAPE AND REEL INFORMATION**

**QUADRANT ASSIGNMENTS FOR PIN 1 ORIENTATION IN TAPE**

\*All dimensions are nominal

| Device          | Package Type | Package Drawing | Pins | SPQ | Reel Diameter (mm) | Reel Width W1 (mm) | A0 (mm) | B0 (mm) | K0 (mm) | P1 (mm) | W (mm) | Pin1 Quadrant |
|-----------------|--------------|-----------------|------|-----|--------------------|--------------------|---------|---------|---------|---------|--------|---------------|
| LM96551SQE/NOPB | WQFN         | NKF             | 80   | 250 | 178.0              | 24.4               | 12.3    | 12.3    | 1.0     | 16.0    | 24.0   | Q1            |

TAPE AND REEL BOX DIMENSIONS



\*All dimensions are nominal

| Device          | Package Type | Package Drawing | Pins | SPQ | Length (mm) | Width (mm) | Height (mm) |
|-----------------|--------------|-----------------|------|-----|-------------|------------|-------------|
| LM96551SQE/NOPB | WQFN         | NKF             | 80   | 250 | 213.0       | 191.0      | 55.0        |

NKF0080A

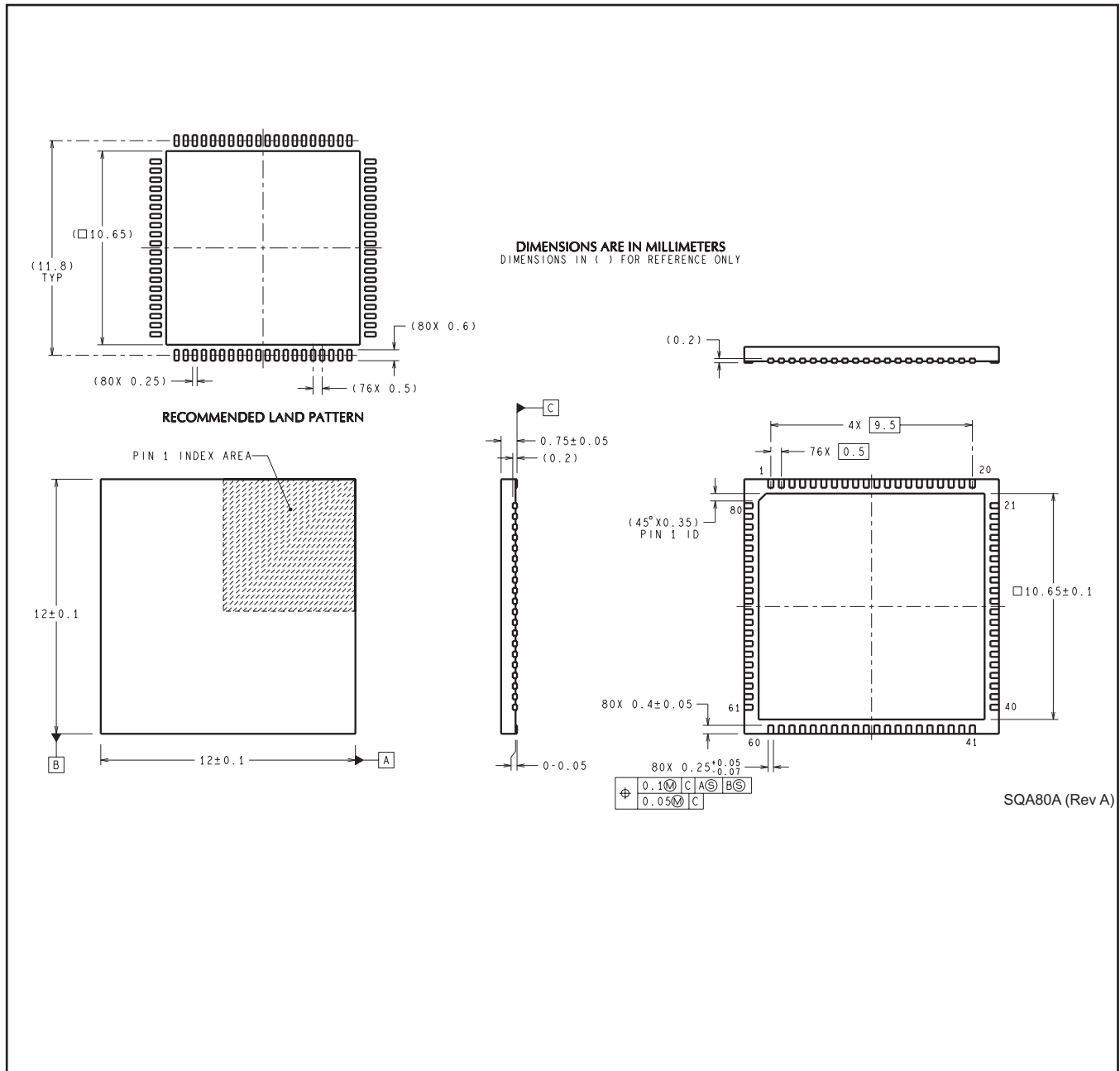

## IMPORTANT NOTICE

Texas Instruments Incorporated and its subsidiaries (TI) reserve the right to make corrections, enhancements, improvements and other changes to its semiconductor products and services per JESD46, latest issue, and to discontinue any product or service per JESD48, latest issue. Buyers should obtain the latest relevant information before placing orders and should verify that such information is current and complete. All semiconductor products (also referred to herein as "components") are sold subject to TI's terms and conditions of sale supplied at the time of order acknowledgment.

TI warrants performance of its components to the specifications applicable at the time of sale, in accordance with the warranty in TI's terms and conditions of sale of semiconductor products. Testing and other quality control techniques are used to the extent TI deems necessary to support this warranty. Except where mandated by applicable law, testing of all parameters of each component is not necessarily performed.

TI assumes no liability for applications assistance or the design of Buyers' products. Buyers are responsible for their products and applications using TI components. To minimize the risks associated with Buyers' products and applications, Buyers should provide adequate design and operating safeguards.

TI does not warrant or represent that any license, either express or implied, is granted under any patent right, copyright, mask work right, or other intellectual property right relating to any combination, machine, or process in which TI components or services are used. Information published by TI regarding third-party products or services does not constitute a license to use such products or services or a warranty or endorsement thereof. Use of such information may require a license from a third party under the patents or other intellectual property of the third party, or a license from TI under the patents or other intellectual property of TI.

Reproduction of significant portions of TI information in TI data books or data sheets is permissible only if reproduction is without alteration and is accompanied by all associated warranties, conditions, limitations, and notices. TI is not responsible or liable for such altered documentation. Information of third parties may be subject to additional restrictions.

Resale of TI components or services with statements different from or beyond the parameters stated by TI for that component or service voids all express and any implied warranties for the associated TI component or service and is an unfair and deceptive business practice. TI is not responsible or liable for any such statements.

Buyer acknowledges and agrees that it is solely responsible for compliance with all legal, regulatory and safety-related requirements concerning its products, and any use of TI components in its applications, notwithstanding any applications-related information or support that may be provided by TI. Buyer represents and agrees that it has all the necessary expertise to create and implement safeguards which anticipate dangerous consequences of failures, monitor failures and their consequences, lessen the likelihood of failures that might cause harm and take appropriate remedial actions. Buyer will fully indemnify TI and its representatives against any damages arising out of the use of any TI components in safety-critical applications.

In some cases, TI components may be promoted specifically to facilitate safety-related applications. With such components, TI's goal is to help enable customers to design and create their own end-product solutions that meet applicable functional safety standards and requirements. Nonetheless, such components are subject to these terms.

No TI components are authorized for use in FDA Class III (or similar life-critical medical equipment) unless authorized officers of the parties have executed a special agreement specifically governing such use.

Only those TI components which TI has specifically designated as military grade or "enhanced plastic" are designed and intended for use in military/aerospace applications or environments. Buyer acknowledges and agrees that any military or aerospace use of TI components which have **not** been so designated is solely at the Buyer's risk, and that Buyer is solely responsible for compliance with all legal and regulatory requirements in connection with such use.

TI has specifically designated certain components as meeting ISO/TS16949 requirements, mainly for automotive use. In any case of use of non-designated products, TI will not be responsible for any failure to meet ISO/TS16949.

### Products

|                              |  |
|------------------------------|--|
| Audio                        | <a href="http://www.ti.com/audio">www.ti.com/audio</a>                               |
| Amplifiers                   | <a href="http://amplifier.ti.com">amplifier.ti.com</a>                               |
| Data Converters              | <a href="http://dataconverter.ti.com">dataconverter.ti.com</a>                       |
| DLP® Products                | <a href="http://www.dlp.com">www.dlp.com</a>   |
| DSP                          | <a href="http://dsp.ti.com">dsp.ti.com</a>   |
| Clocks and Timers            | <a href="http://www.ti.com/clocks">www.ti.com/clocks</a>                             |
| Interface                    | <a href="http://interface.ti.com">interface.ti.com</a>                               |
| Logic                        | <a href="http://logic.ti.com">logic.ti.com</a>                                       |
| Power Mgmt                   | <a href="http://power.ti.com">power.ti.com</a>                                       |
| Microcontrollers             | <a href="http://microcontroller.ti.com">microcontroller.ti.com</a>                   |
| RFID                         | <a href="http://www.ti-rfid.com">www.ti-rfid.com</a>                                 |
| OMAP Applications Processors | <a href="http://www.ti.com/omap">www.ti.com/omap</a>                                 |
| Wireless Connectivity        | <a href="http://www.ti.com/wirelessconnectivity">www.ti.com/wirelessconnectivity</a> |

### Applications



|                               |  |
|-------------------------------|--|
| Automotive and Transportation | <a href="http://www.ti.com/automotive">www.ti.com/automotive</a>                         |
| Communications and Telecom    | <a href="http://www.ti.com/communications">www.ti.com/communications</a>                 |
| Computers and Peripherals     | <a href="http://www.ti.com/computers">www.ti.com/computers</a>                           |
| Consumer Electronics          | <a href="http://www.ti.com/consumer-apps">www.ti.com/consumer-apps</a>                   |
| Energy and Lighting           | <a href="http://www.ti.com/energy">www.ti.com/energy</a>                                 |
| Industrial                    | <a href="http://www.ti.com/industrial">www.ti.com/industrial</a>                         |
| Medical                       | <a href="http://www.ti.com/medical">www.ti.com/medical</a>                               |
| Security                      | <a href="http://www.ti.com/security">www.ti.com/security</a>                             |
| Space, Avionics and Defense   | <a href="http://www.ti.com/space-avionics-defense">www.ti.com/space-avionics-defense</a> |
| Video and Imaging             | <a href="http://www.ti.com/video">www.ti.com/video</a>                                   |

### TI E2E Community

[e2e.ti.com](http://e2e.ti.com)

## Looking for pricing, stock, or lifecycle information?

Click below to explore more details on WIN SOURCE:

-  [View LM96551SQE/NOPB on WIN SOURCE](#)
-  [Texas Instruments](#) Information

## Optimize Your Supply Chain with WIN SOURCE Solutions

-  Global Sourcing Solution
-  Obsolete Management
-  Cost Control Management
-  Shortage Management
-  Alternative Solution
-  Excess Inventory Management