



THE DATASHEET OF LM529CH



LM161/LM361 High Speed Differential Comparators

 Check for Samples: [LM161](#), [LM361](#)

FEATURES

- Independent strobes
- Ensured high speed: 20 ns max
- Tight delay matching on both outputs
- Complementary TTL outputs
- Operates from op amp supplies: $\pm 15V$
- Low speed variation with overdrive variation
- Low input offset voltage
- Versatile supply voltage range

DESCRIPTION

The LM161/LM361 is a very high speed differential input, complementary TTL output voltage comparator with improved characteristics over the SE529/NE529 for which it is a pin-for-pin replacement. The device has been optimized for greater speed performance and lower input offset voltage. Typically delay varies only 3 ns for over-drive variations of 5 mV to 500 mV. It may be operated from op amp supplies ($\pm 15V$).

Complementary outputs having maximum skew are provided. Applications involve high speed analog to digital converters and zero-crossing detectors in disk file systems.

CONNECTION DIAGRAMS

SOIC or PDIP Package

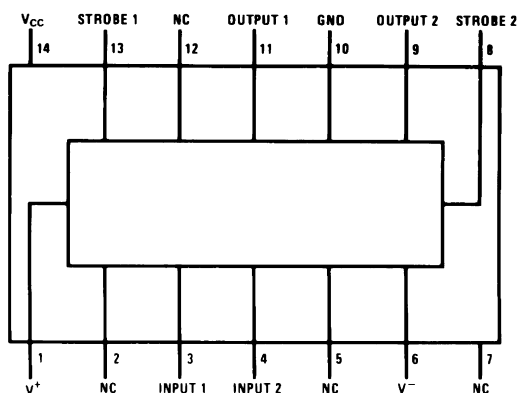

Figure 1. Top View
Package Numbers D0014A, NFF0014A

TO-100 Package

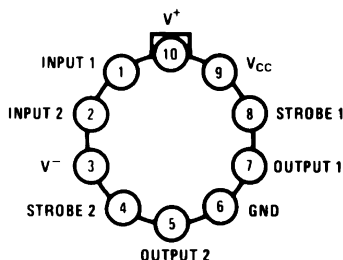

Figure 2. Package Number LME0010C



Please be aware that an important notice concerning availability, standard warranty, and use in critical applications of Texas Instruments semiconductor products and disclaimers thereto appears at the end of this data sheet.

All trademarks are the property of their respective owners.

LOGIC DIAGRAM

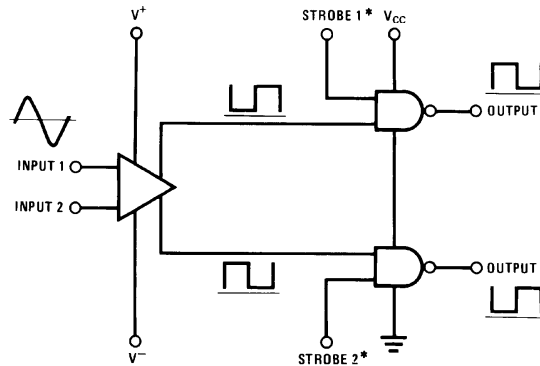

*Output is low when current is drawn from strobe pin.



These devices have limited built-in ESD protection. The leads should be shorted together or the device placed in conductive foam during storage or handling to prevent electrostatic damage to the MOS gates.

Absolute Maximum Ratings ⁽¹⁾

Positive Supply Voltage, V ⁺	+16V
Negative Supply Voltage, V ⁻	-16V
Gate Supply Voltage, V _{CC}	+7V
Output Voltage	+7V
Differential Input Voltage	±5V
Input Common Mode Voltage	±6V
Power Dissipation	600 mW
Storage Temperature Range	-65°C to +150°C
Operating Temperature Range	T_{MIN} T_{MAX}
LM161	-55°C to +125°C
	-25°C to +85°C
LM361	0°C to +70°C
Lead Temp. (Soldering, 10 seconds)	260°C
For Any Device Lead Below V ⁻	0.3V

(1) The device may be damaged by use beyond the maximum ratings.

Operating Conditions

		Min	Typ	Max
Supply Voltage V ⁺	LM161	5V		15V
	LM361	5V		15V
Supply Voltage V ⁻	LM161	-6V		-15V
	LM361	-6V		-15V
Supply Voltage V _{CC}	LM161	4.5V	5V	5.5V
	LM361	4.75V	5V	5.25V
ESD Tolerance ⁽¹⁾				1600V
Soldering Information ⁽²⁾	PDIP Package	Soldering (10 seconds) ⁽²⁾		260°C
	SOIC Package	Vapor Phase (60 seconds)		215°C
		Infrared (15 seconds)		220°C

(1) Human body model, 1.5 kΩ in series with 100 pF.

(2) See AN-450 "Surface Mounting Methods and Their Effect on Product Reliability" for other methods of soldering surface mount devices.

Electrical Characteristics⁽¹⁾⁽²⁾⁽¹⁾
 $(V^+ = +10V, V_{CC} = +5V, V^- = -10V, T_{MIN} \leq T_A \leq T_{MAX}, \text{ unless noted})$

Parameter	Conditions	Limits						Units
		LM161			LM361			
		Min	Typ	Max	Min	Typ	Max	
Input Offset Voltage			1	3		1	5	mV
Input Bias Current	$T_A=25^\circ\text{C}$		5	20		10	30	μA μA
Input Offset Current	$T_A=25^\circ\text{C}$		2	3		2	5	μA μA
Voltage Gain	$T_A=25^\circ\text{C}$		3			3		V/mV
Input Resistance	$T_A=25^\circ\text{C}, f=1\text{ kHz}$		20			20		k Ω
Logical "1" Output Voltage	$V_{CC}=4.75V,$ $I_{SOURCE}=-0.5\text{ mA}$	2.4	3.3		2.4	3.3		V
Logical "0" Output Voltage	$V_{CC}=4.75V,$ $I_{SINK}=6.4\text{ mA}$			0.4			0.4	V
Strobe Input "1" Current (Output Enabled)	$V_{CC}=5.25V,$ $V_{STROBE}=2.4V$			200			200	μA
Strobe Input "0" Current (Output Disabled)	$V_{CC}=5.25V,$ $V_{STROBE}=0.4V$			-1.6			-1.6	mA
Strobe Input "0" Voltage	$V_{CC}=4.75V$			0.8			0.8	V
Strobe Input "1" Voltage	$V_{CC}=4.75V$	2			2			V
Output Short Circuit Current	$V_{CC}=5.25V, V_{OUT}=0V$	-18		-55	-18		-55	mA
Supply Current I^+	$V^+=10V, V^-=-10V,$ $V_{CC}=5.25V,$ $-55^\circ\text{C} \leq T_A \leq 125^\circ\text{C}$			4.5				mA
Supply Current I^+	$V^+=10V, V^-=-10V,$ $V_{CC}=5.25V,$ $0^\circ\text{C} \leq T_A \leq 70^\circ\text{C}$						5	mA
Supply Current I^-	$V^+=10V, V^-=-10V,$ $V_{CC}=5.25V,$ $-55^\circ\text{C} \leq T_A \leq 125^\circ\text{C}$			10				mA
Supply Current I^-	$V^+=10V,$ $V^-=-10V, V_{CC}=5.25V,$ $0^\circ\text{C} \leq T_A \leq 70^\circ\text{C}$						10	mA
Supply Current I_{CC}	$V^+=10V, V^-=-10V,$ $V_{CC}=5.25V,$ $-55^\circ\text{C} \leq T_A \leq 125^\circ\text{C}$			18				mA
Supply Current I_{CC}	$V^+=10V, V^-=-10V,$ $V_{CC}=5.25V,$ $0^\circ\text{C} \leq T_A \leq 70^\circ\text{C}$						20	mA
Transient Response	$V_{IN} = 50\text{ mV overdrive}^{(3)}$							
Propagation Delay Time ($t_{pd(0)}$)	$T_A=25^\circ\text{C}$		14	20		14	20	ns
Propagation Delay Time ($t_{pd(1)}$)	$T_A=25^\circ\text{C}$		14	20		14	20	ns
Delay Between Output A and B	$T_A=25^\circ\text{C}$		2	5		2	5	ns
Strobe Delay Time ($t_{pd(0)}$)	$T_A=25^\circ\text{C}$		8			8		ns
Strobe Delay Time ($t_{pd(1)}$)	$T_A=25^\circ\text{C}$		8			8		ns

(1) Typical thermal impedances are as follows:

	H Package	J Package	N Package
θ_{JA}	165°C/W (Still Air) 67°C/W (400 LF/Min Air Flow)	112°C/W	105°C/W
θ_{JC}	25°C/W		

(2) Refer to RETS161X for LM161H and LM161J military specifications.

(3) Measurements using AC Test circuit, Fanout = 1. The devices are faster at low supply voltages.

Typical Performance Characteristics

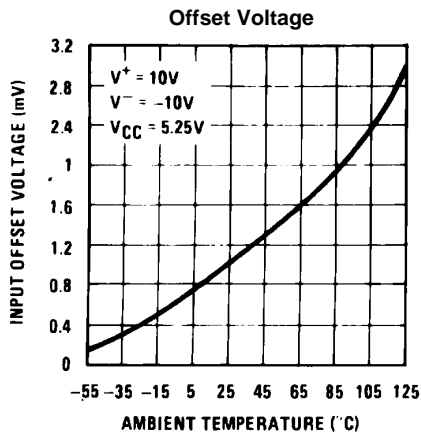

Figure 3.

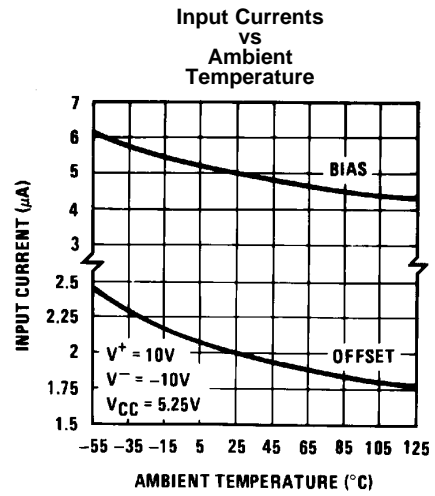

Figure 4.

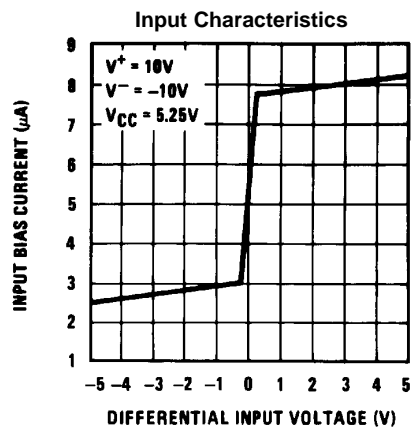

Figure 5.

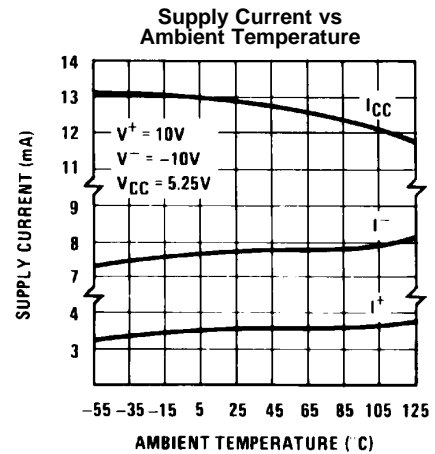

Figure 6.

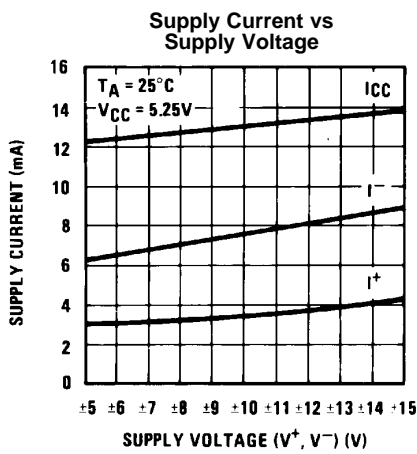

Figure 7.

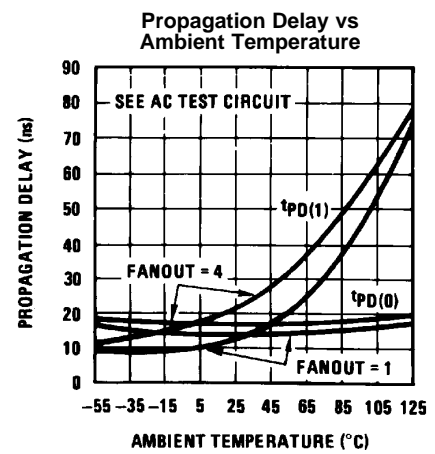

Figure 8.

Typical Performance Characteristics (continued)

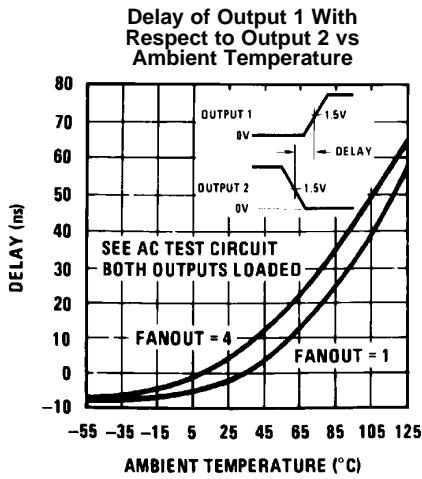

Figure 9.

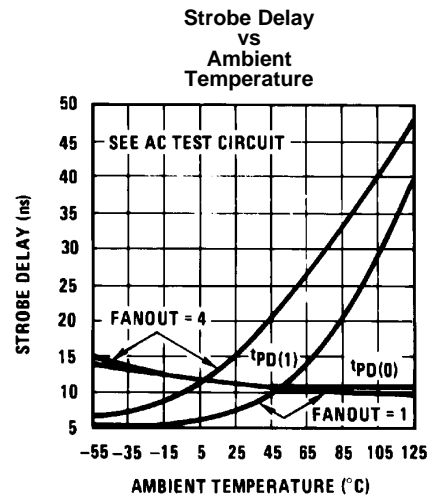

Figure 10.

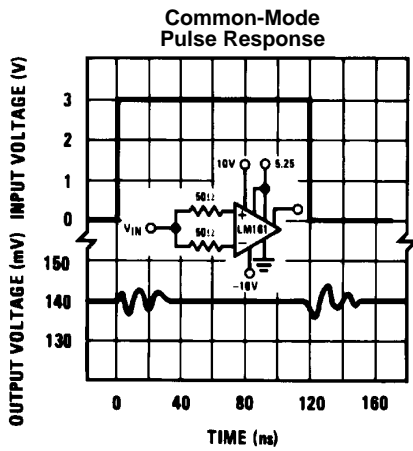

Figure 11.

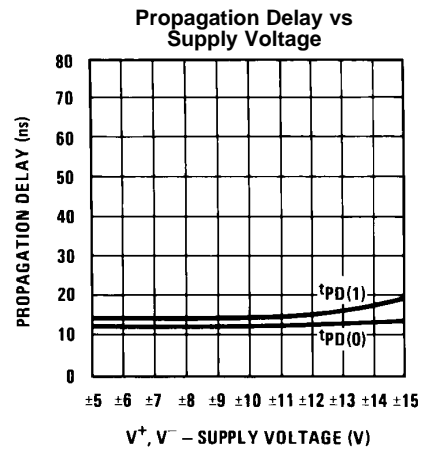
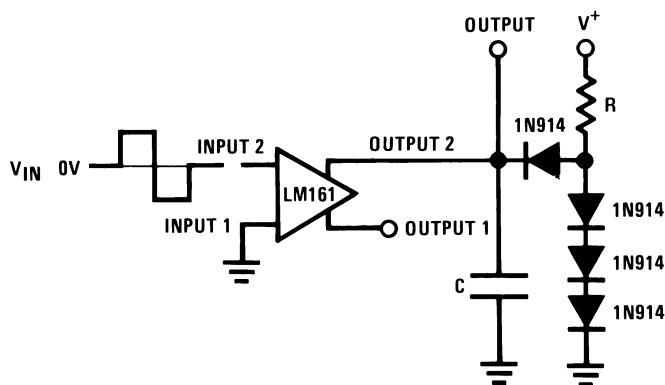

Figure 12.

AC TEST CIRCUIT



$V_{IN} = \pm 50 \text{ mV}$	FANOUT = 1	FANOUT = 4	$V^- = -10\text{V}$	$C = 15 \text{ pF}$	$C = 30 \text{ pF}$
$V^+ = +10\text{V}$	$R = 2.4\text{k}$	$R = 680\Omega$	$V_{CC} = 5.25\text{V}$		

SCHMATIC DIAGRAM

LM161

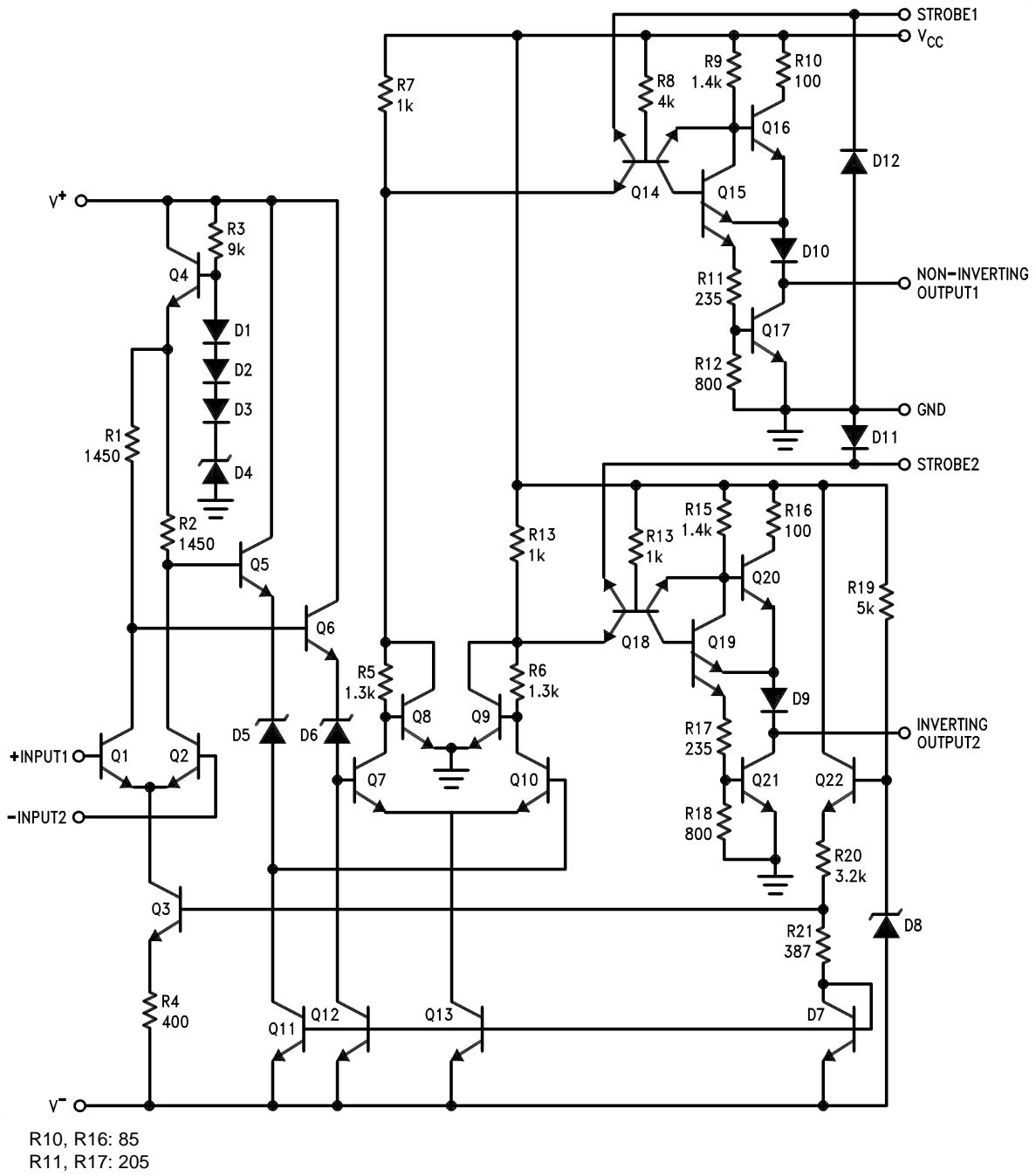

REVISION HISTORY

Changes from Revision B (March 2013) to Revision C	Page
• Changed layout of National Data Sheet to TI format	7

PACKAGING INFORMATION

Orderable Device	Status (1)	Package Type	Package Drawing	Pins	Package Qty	Eco Plan (2)	Lead/Ball Finish (6)	MSL Peak Temp (3)	Op Temp (°C)	Device Marking (4/5)	Samples
LM361H/NOPB	ACTIVE	TO-100	LME	10	500	Green (RoHS & no Sb/Br)	Call TI	Level-1-NA-UNLIM	0 to 70	(LM361H, LM361H)	Samples
LM361M	NRND	SOIC	D	14	55	TBD	Call TI	Call TI	0 to 70	LM361M	
LM361M/NOPB	ACTIVE	SOIC	D	14	55	Green (RoHS & no Sb/Br)	CU SN	Level-1-260C-UNLIM	0 to 70	LM361M	Samples
LM361MX/NOPB	ACTIVE	SOIC	D	14	2500	Green (RoHS & no Sb/Br)	CU SN	Level-1-260C-UNLIM	0 to 70	LM361M	Samples
LM361N/NOPB	ACTIVE	PDIP	NFF	14	25	Green (RoHS & no Sb/Br)	CU SN	Level-1-NA-UNLIM	0 to 70	LM361N	Samples

(1) The marketing status values are defined as follows:

ACTIVE: Product device recommended for new designs.

LIFEBUY: TI has announced that the device will be discontinued, and a lifetime-buy period is in effect.

NRND: Not recommended for new designs. Device is in production to support existing customers, but TI does not recommend using this part in a new design.

PREVIEW: Device has been announced but is not in production. Samples may or may not be available.

OBSELETE: TI has discontinued the production of the device.

(2) **RoHS:** TI defines "RoHS" to mean semiconductor products that are compliant with the current EU RoHS requirements for all 10 RoHS substances, including the requirement that RoHS substance do not exceed 0.1% by weight in homogeneous materials. Where designed to be soldered at high temperatures, "RoHS" products are suitable for use in specified lead-free processes. TI may reference these types of products as "Pb-Free".

RoHS Exempt: TI defines "RoHS Exempt" to mean products that contain lead but are compliant with EU RoHS pursuant to a specific EU RoHS exemption.

Green: TI defines "Green" to mean the content of Chlorine (Cl) and Bromine (Br) based flame retardants meet JS709B low halogen requirements of <=1000ppm threshold. Antimony trioxide based flame retardants must also meet the <=1000ppm threshold requirement.

(3) MSL, Peak Temp. - The Moisture Sensitivity Level rating according to the JEDEC industry standard classifications, and peak solder temperature.

(4) There may be additional marking, which relates to the logo, the lot trace code information, or the environmental category on the device.

(5) Multiple Device Markings will be inside parentheses. Only one Device Marking contained in parentheses and separated by a "-" will appear on a device. If a line is indented then it is a continuation of the previous line and the two combined represent the entire Device Marking for that device.

(6) Lead/Ball Finish - Orderable Devices may have multiple material finish options. Finish options are separated by a vertical ruled line. Lead/Ball Finish values may wrap to two lines if the finish value exceeds the maximum column width.

Important Information and Disclaimer: The information provided on this page represents TI's knowledge and belief as of the date that it is provided. TI bases its knowledge and belief on information provided by third parties, and makes no representation or warranty as to the accuracy of such information. Efforts are underway to better integrate information from third parties. TI has taken and continues to take reasonable steps to provide representative and accurate information but may not have conducted destructive testing or chemical analysis on incoming materials and chemicals. TI and TI suppliers consider certain information to be proprietary, and thus CAS numbers and other limited information may not be available for release.

In no event shall TI's liability arising out of such information exceed the total purchase price of the TI part(s) at issue in this document sold by TI to Customer on an annual basis.

TAPE AND REEL INFORMATION

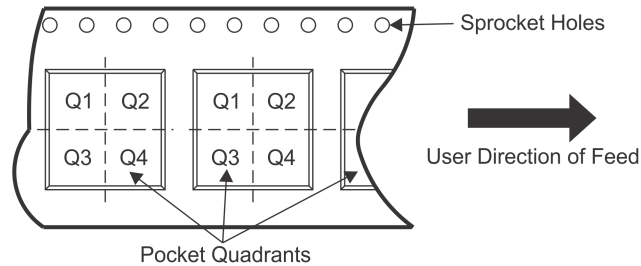
QUADRANT ASSIGNMENTS FOR PIN 1 ORIENTATION IN TAPE

*All dimensions are nominal

Device	Package Type	Package Drawing	Pins	SPQ	Reel Diameter (mm)	Reel Width W1 (mm)	A0 (mm)	B0 (mm)	K0 (mm)	P1 (mm)	W (mm)	Pin1 Quadrant
LM361MX/NOPB	SOIC	D	14	2500	330.0	16.4	6.5	9.35	2.3	8.0	16.0	Q1

TAPE AND REEL BOX DIMENSIONS

*All dimensions are nominal

Device	Package Type	Package Drawing	Pins	SPQ	Length (mm)	Width (mm)	Height (mm)
LM361MX/NOPB	SOIC	D	14	2500	367.0	367.0	35.0

GENERIC PACKAGE VIEW

LME 10

TO-CAN - 5.72 mm max height

METAL CYLINDRICAL PACKAGE

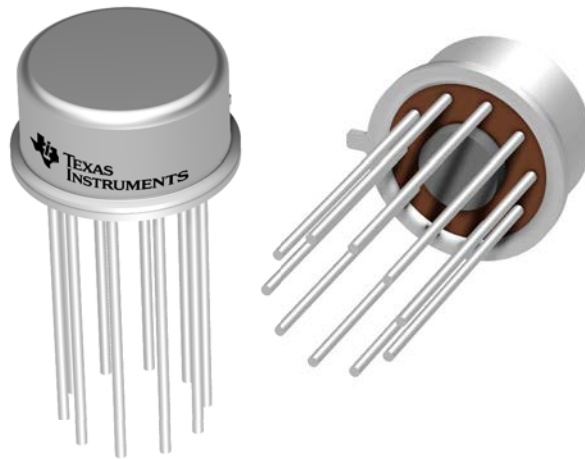

Images above are just a representation of the package family, actual package may vary.
Refer to the product data sheet for package details.

4202488/B

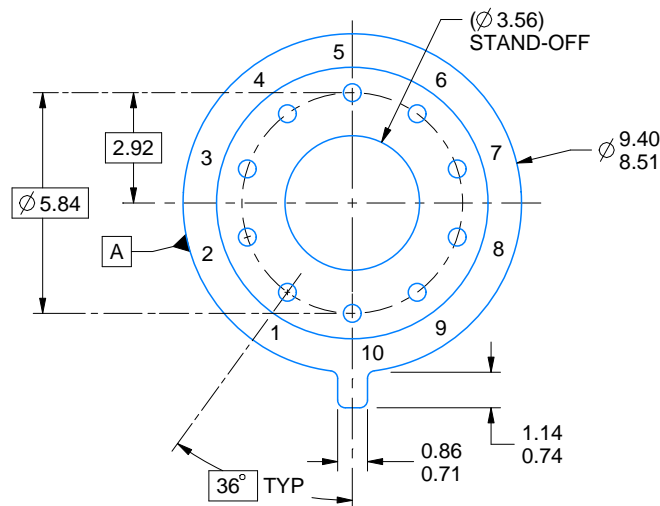
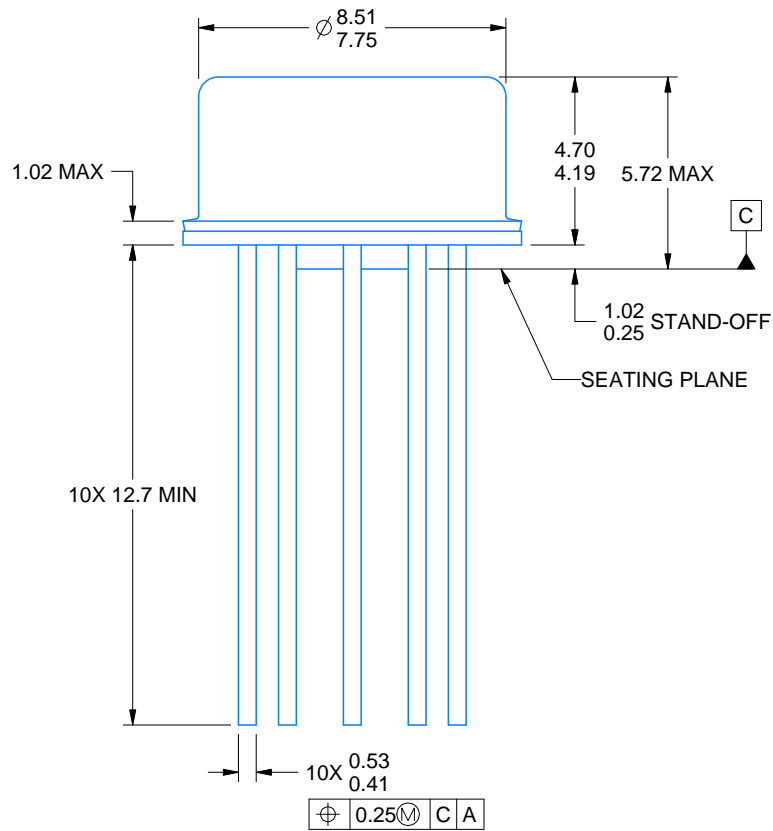

4220604/A 05/2017

NOTES:

1. All linear dimensions are in millimeters. Any dimensions in parenthesis are for reference only. Dimensioning and tolerancing per ASME Y14.5M.
2. This drawing is subject to change without notice.
3. Reference JEDEC registration MO-006/TO-100.

D (R-PDSO-G14)

PLASTIC SMALL OUTLINE

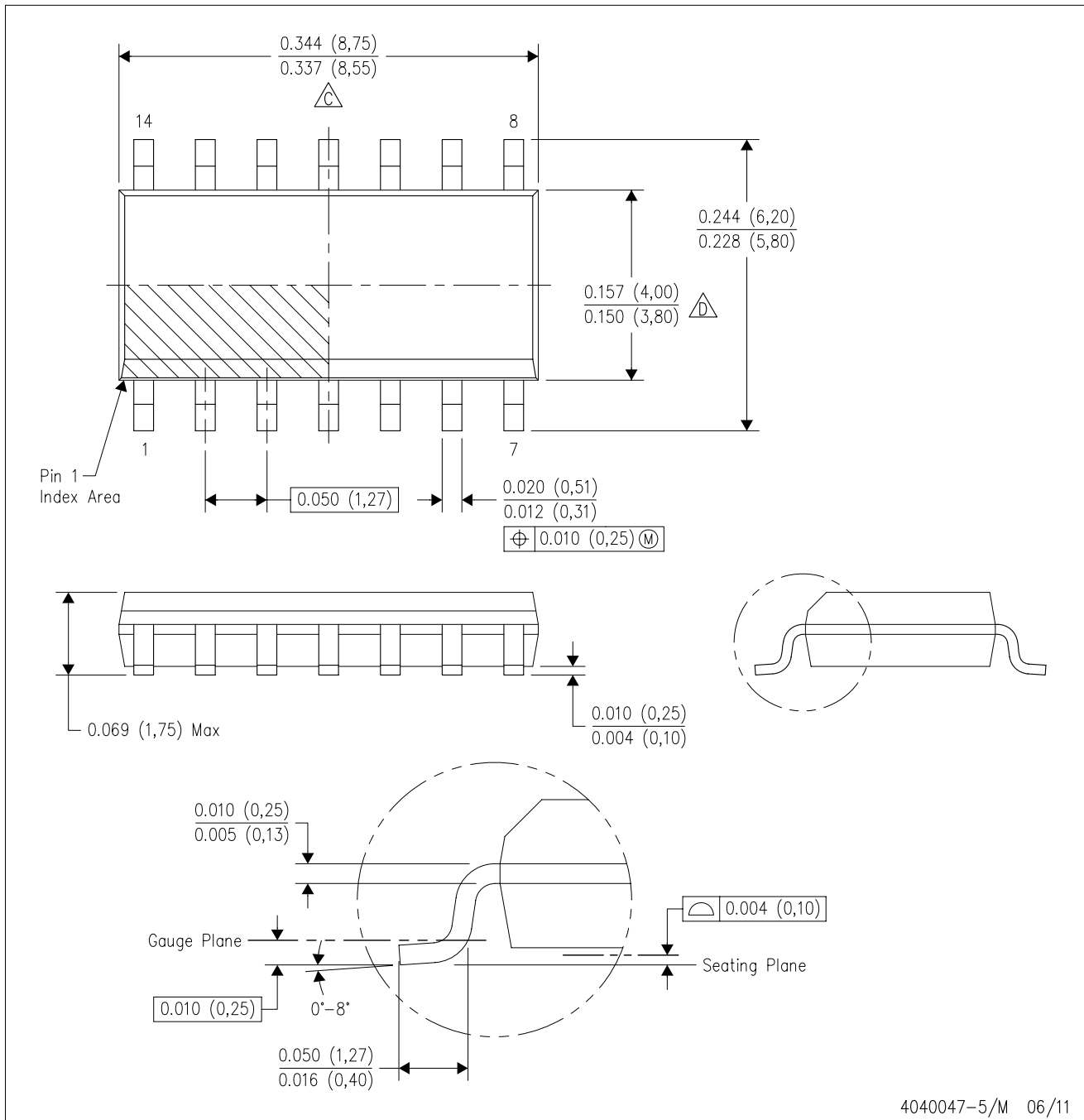

- NOTES:
- A. All linear dimensions are in inches (millimeters).
 - B. This drawing is subject to change without notice.
 - $\triangle C$ Body length does not include mold flash, protrusions, or gate burrs. Mold flash, protrusions, or gate burrs shall not exceed 0.006 (0,15) each side.
 - $\triangle D$ Body width does not include interlead flash. Interlead flash shall not exceed 0.017 (0,43) each side.
 - E. Reference JEDEC MS-012 variation AB.

D (R-PDSO-G14)

PLASTIC SMALL OUTLINE



- NOTES:
- All linear dimensions are in millimeters.
 - This drawing is subject to change without notice.
 - Publication IPC-7351 is recommended for alternate designs.
 - Laser cutting apertures with trapezoidal walls and also rounding corners will offer better paste release. Customers should contact their board assembly site for stencil design recommendations. Refer to IPC-7525 for other stencil recommendations.
 - Customers should contact their board fabrication site for solder mask tolerances between and around signal pads.

N0014A

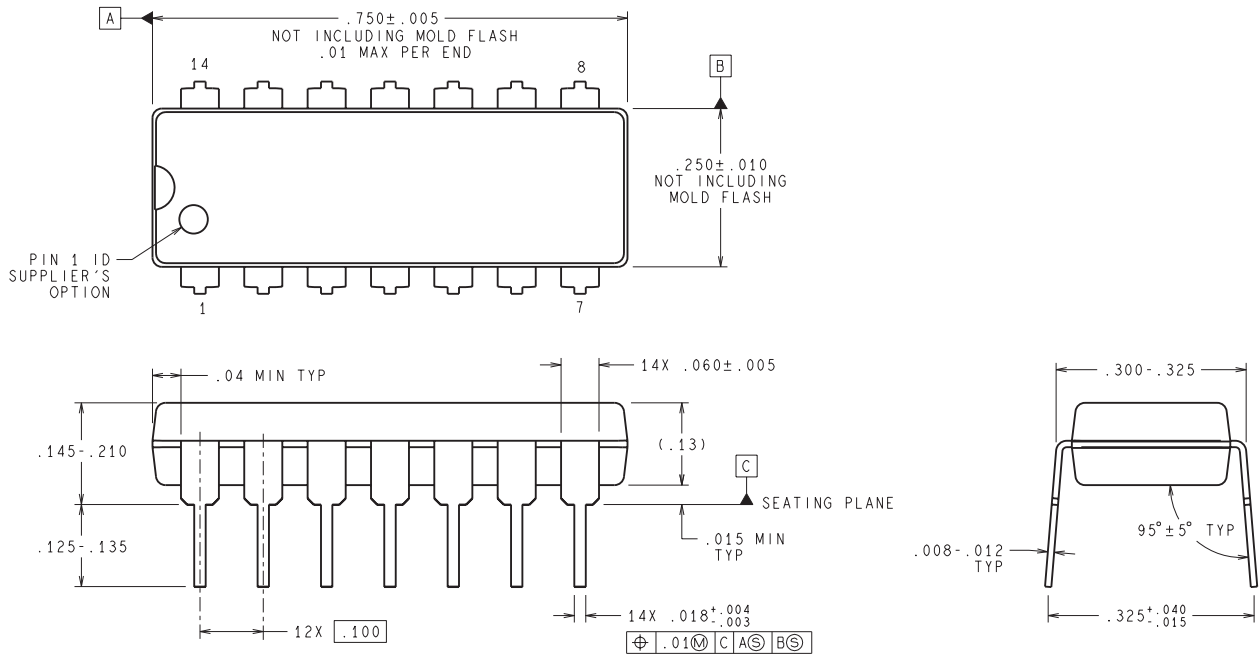

DIMENSIONS ARE IN INCHES
 DIMENSIONS IN () FOR REFERENCE ONLY

N14A (Rev G)

IMPORTANT NOTICE AND DISCLAIMER

TI PROVIDES TECHNICAL AND RELIABILITY DATA (INCLUDING DATASHEETS), DESIGN RESOURCES (INCLUDING REFERENCE DESIGNS), APPLICATION OR OTHER DESIGN ADVICE, WEB TOOLS, SAFETY INFORMATION, AND OTHER RESOURCES "AS IS" AND WITH ALL FAULTS, AND DISCLAIMS ALL WARRANTIES, EXPRESS AND IMPLIED, INCLUDING WITHOUT LIMITATION ANY IMPLIED WARRANTIES OF MERCHANTABILITY, FITNESS FOR A PARTICULAR PURPOSE OR NON-INFRINGEMENT OF THIRD PARTY INTELLECTUAL PROPERTY RIGHTS.



These resources are intended for skilled developers designing with TI products. You are solely responsible for (1) selecting the appropriate TI products for your application, (2) designing, validating and testing your application, and (3) ensuring your application meets applicable standards, and any other safety, security, or other requirements. These resources are subject to change without notice. TI grants you permission to use these resources only for development of an application that uses the TI products described in the resource. Other reproduction and display of these resources is prohibited. No license is granted to any other TI intellectual property right or to any third party intellectual property right. TI disclaims responsibility for, and you will fully indemnify TI and its representatives against, any claims, damages, costs, losses, and liabilities arising out of your use of these resources.

TI's products are provided subject to TI's Terms of Sale (www.ti.com/legal/termsofsale.html) or other applicable terms available either on ti.com or provided in conjunction with such TI products. TI's provision of these resources does not expand or otherwise alter TI's applicable warranties or warranty disclaimers for TI products.

Mailing Address: Texas Instruments, Post Office Box 655303, Dallas, Texas 75265
Copyright © 2019, Texas Instruments Incorporated

Looking for pricing, stock, or lifecycle information?

Click below to explore more details on WIN SOURCE:

-  [View LM529CH](#) on WIN SOURCE
-  [Texas Instruments](#) Information

Optimize Your Supply Chain with WIN SOURCE Solutions

-  Global Sourcing Solution
-  Obsolete Management
-  Cost Control Management
-  Shortage Management
-  Alternative Solution
-  Excess Inventory Management