



**THE DATASHEET OF
LM5056APMHX/NOPB**



High-Voltage System Power Management Device with PMBus™

Check for Samples: [LM5056](#), [LM5056A](#)

FEATURES

- **Input Voltage Range: 10 V to 80 V**
- **Real-Time Monitoring of VIN, IIN, PIN, VOUT, and VAUX with 12-bit resolution, 1-kHz sampling rate**
- **True input Power Measurement using simultaneous sampling of Vin and Iin**
- **Remote Temperature Sensing with programmable warning thresholds**
- **Power Measurement Accuracy**
 - LM5056A: $\pm 1.75\%$
 - LM5056: $\pm 2.25\%$
- **Current Measurement Accuracy**
 - LM5056A: $\pm 1.25\%$
 - LM5056: $\pm 1.5\%$
- **Voltage Measurement Accuracy: $\pm 1.0\%$**
- **Averaging of VIN, IIN, PIN, and VOUT with Programmable Interval Ranging from 0.001 s to 4 s**
- **Programmable WARN and FAULT Thresholds with SMBA Notification**
- **Black-Box Capture of Telemetry Measurements and Device Status Triggered by WARN or FAULT Condition**
- **I²C/SMBus Interface and PMBus Compliant Command Structure**

APPLICATIONS

- **Server Backplane Systems**
- **Base Station Power Distribution Systems**
- **Industrial Telemetry Applications**

DESCRIPTION

The LM5056/LM5056A combines high-performance analog and digital technology with a PMBus™ compliant SMBus™ and I²C interface to accurately measure the electrical operating conditions of systems connected to a backplane power bus. The LM5056/LM5056A continuously supplies real-time power, voltage, current, temperature and fault data to the system management host via the SMBus interface.

The LM5056/LM5056A monitoring block computes both the real time and average values of subsystem operating parameters (VIN, IIN, PIN, VOUT) as well as the peak power. Accurate power averaging is accomplished by averaging the product of the input voltage and current. A black-box (telemetry and fault snapshot) function captures and stores telemetry data and device status in the event of a warning or a fault.



Please be aware that an important notice concerning availability, standard warranty, and use in critical applications of Texas Instruments semiconductor products and disclaimers thereto appears at the end of this data sheet.

PMBus is a trademark of Texas Instruments.

PRODUCTION DATA information is current as of publication date. Products conform to specifications per the terms of the Texas Instruments standard warranty. Production processing does not necessarily include testing of all parameters.

Copyright © 2012–2013, Texas Instruments Incorporated

TYPICAL APPLICATION DIAGRAM

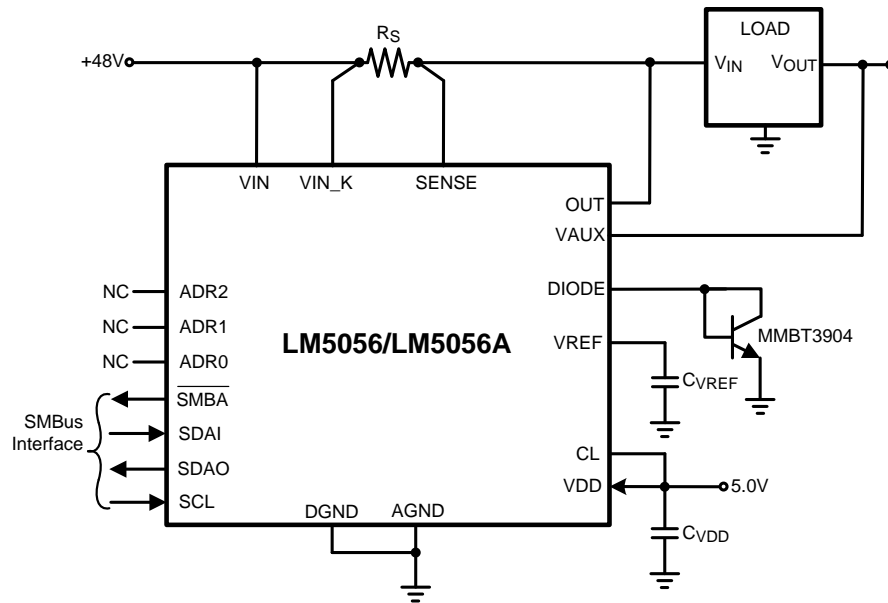



This integrated circuit can be damaged by ESD. Texas Instruments recommends that all integrated circuits be handled with appropriate precautions. Failure to observe proper handling and installation procedures can cause damage.

ESD damage can range from subtle performance degradation to complete device failure. Precision integrated circuits may be more susceptible to damage because very small parametric changes could cause the device not to meet its published specifications.

ABSOLUTE MAXIMUM RATINGS

over operating free-air temperature range (unless otherwise noted)⁽¹⁾

		VALUE	UNIT
VIN, VIN_K, SENSE, OUT to AGND/DGND		-0.3 to 100	V
$\overline{\text{SMBA}}$, SCL, SDAI, SDAO, CL, ADR0, ADR1, ADR2, VDD, VAUX, DIODE to AGND/DGND		-0.3 to 6.0	
VIN to VIN_K, AGND to DGND		-0.3 to 0.3	
VIN_K to SENSE		-3.0 to 3.0	
HBM	Human body model ESD rating ⁽²⁾	2.0	kV
T _{STG}	Storage temperature	-65 to 150	°C
T _J	Junction temperature	150	

(1) Absolute Maximum Ratings indicate limits beyond which damage to the device may occur. Operating ratings indicate conditions for which the device is intended to be functional, but do not ensure specific performance limits. For ensured specifications and conditions see Electrical Characteristics Table.

(2) The human body model is a 100-pF capacitor discharged through a 1.5-kΩ resistor into each pin.

RECOMMENDED OPERATING CONDITIONS

over operating free-air temperature range (unless otherwise noted)⁽¹⁾

	MIN	NOM	MAX	UNIT
VIN, VIN_K, SENSE, OUT	10		80	V
VDD	4.5	5.0	5.5	
VAUX	0		2.97	

(1) Absolute Maximum Ratings indicate limits beyond which damage to the device may occur. Operating ratings indicate conditions for which the device is intended to be functional, but do not ensure specific performance limits. For ensured specifications and conditions see the Electrical Characteristics Table.

THERMAL INFORMATION

THERMAL METRIC ⁽¹⁾		LM5056	UNITS
		PWP	
		28 PINS	
θ_{JA}	Junction-to-ambient thermal resistance ⁽²⁾	35.6	°C/W
θ_{JcTop}	Junction-to-case (top) thermal resistance ⁽³⁾	19.9	
θ_{JB}	Junction-to-board thermal resistance ⁽⁴⁾	16.8	
ψ_{JT}	Junction-to-top characterization parameter ⁽⁵⁾	0.5	
ψ_{JB}	Junction-to-board characterization parameter ⁽⁶⁾	16.7	
θ_{JcBot}	Junction-to-case (bottom) thermal resistance ⁽⁷⁾	2.9	

(1) For more information about traditional and new thermal metrics, see the *IC Package Thermal Metrics* application report, [SPRA953](#).

(2) The junction-to-ambient thermal resistance under natural convection is obtained in a simulation on a JEDEC-standard, high-K board, as specified in JESD51-7, in an environment described in JESD51-2a.

(3) The junction-to-case (top) thermal resistance is obtained by simulating a cold plate test on the package top. No specific JEDEC-standard test exists, but a close description can be found in the ANSI SEMI standard G30-88.

(4) The junction-to-board thermal resistance is obtained by simulating in an environment with a ring cold plate fixture to control the PCB temperature, as described in JESD51-8.

(5) The junction-to-top characterization parameter, ψ_{JT} , estimates the junction temperature of a device in a real system and is extracted from the simulation data for obtaining θ_{JA} , using a procedure described in JESD51-2a (sections 6 and 7).

(6) The junction-to-board characterization parameter, ψ_{JB} , estimates the junction temperature of a device in a real system and is extracted from the simulation data for obtaining θ_{JA} , using a procedure described in JESD51-2a (sections 6 and 7).

(7) The junction-to-case (bottom) thermal resistance is obtained by simulating a cold plate test on the exposed (power) pad. No specific JEDEC standard test exists, but a close description can be found in the ANSI SEMI standard G30-88.

ELECTRICAL CHARACTERISTICS

Limits in standard type are for $T_J = 25^\circ\text{C}$ only; limits in boldface type apply over the junction temperature (T_J) range of -40°C to 125°C unless otherwise stated. Minimum and maximum limits are ensured through test, design, or statistical correlation. Typical values represent the most likely parametric norm at $T_J = 25^\circ\text{C}$, and are provided for reference purposes only. Unless otherwise stated the following conditions apply: $V_{IN} = 48\text{ V}$ and $V_{DD} = 5.0\text{ V}$. See ⁽¹⁾ and ⁽²⁾.

PARAMETER		TEST CONDITIONS	MIN	TYP	MAX	UNIT
Input (VIN Pin)						
I_{VIN}	VIN input current	$V_{IN} = 48\text{ V}$		0.9	1.4	mA
POR_{EN}	Power on reset threshold at VIN to enable all functions	VIN increasing	7.5	8.7	9.7	V
POR_{EN_HYST}	POR_{EN} hysteresis	VIN decreasing		150		mV
VDD Regulator (VDD pin)						
V_{DDPOR}	VDD power on reset voltage threshold	VDD rising	3.0	3.8	4.5	V
I_{DD}	VDD pin input current	$V_{DD} = 5.5\text{ V}$		6.1	6.8	mA
OUT, SENSE, VIN_K, VAUX Pins						
I_{OUT}	OUT bias current	OUT = VIN, normal operation		79	90	μA
I_{SENSE}	SENSE bias current	SENSE = VIN, normal operation		11		
I_{VIN_K}	VIN_K bias current	VIN_K = VIN, normal operation		110		
I_{VAUX}	VAUXH bias current	VAUX = 2.97 V			1.0	
Internal Reference						
V_{REF}	Reference voltage	$I_{REF} = 0\text{ mA}$	2.94	2.97	3.0	V
ADC and MUX						
ADC_{RES}	Resolution			12		bits
INL	Integral non-linearity	ADC only		± 4		LSB
t_{RR}	Acquisition round-robin time	Cycle all channels		1		ms
Remote Diode Temperature Sensor						
T_{ACC}	Temperature accuracy using local diode	$T_A = 25^\circ\text{C}$ to 85°C		2		$^\circ\text{C}$
	Remote diode resolution			9		bits
I_{DIODE}	External diode current source	High level		250		μA
		Low level		9.4		
D_{RATIO}	Diode current ratio			25.9		

(1) Current out of a pin is indicated as a negative value.

(2) All limits are ensured. All electrical characteristics having room temperature limits are tested during production at $T_A = 25^\circ\text{C}$. All hot and cold limits are ensured by correlating the electrical characteristics to process and temperature variations and applying statistical process control.

ELECTRICAL CHARACTERISTICS (continued)

Limits in standard type are for $T_J = 25^\circ\text{C}$ only; limits in boldface type apply over the junction temperature (T_J) range of -40°C to 125°C unless otherwise stated. Minimum and maximum limits are ensured through test, design, or statistical correlation. Typical values represent the most likely parametric norm at $T_J = 25^\circ\text{C}$, and are provided for reference purposes only. Unless otherwise stated the following conditions apply: $V_{IN} = 48\text{ V}$ and $V_{DD} = 5.0\text{ V}$. See ⁽¹⁾ and ⁽²⁾.

PARAMETER		TEST CONDITIONS	MIN	TYP	MAX	UNIT
Telemetry Accuracy						
IIN _{FSR}	Current input full scale range	CL = GND		54.4		mV
		CL = VDD		27.0		
IIN _{LSB}	Current input LSB	CL = GND		13.3 0		μV
		CL = VDD		6.70		
VAUX _{FSR}	VAUX input full scale range			2.96 6		V
VAUX _{LSB}	VAUX input LSB			724		μV
VIN _{FSR}	Input voltage full scale range			88.9		V
VIN _{LSB}	Input voltage LSB			21.7		mV
IIN _{ACC}	Input current accuracy	VIN_K – SENSE_K = 22 mV, CL = VDD (80% IIN _{FSR}), T _J = 0°C to 85°C	-1.5		1.5	%
		VIN_K – SENSE_K = 22 mV, CL = VDD (80% IIN _{FSR}), LM5056A T _J = 0°C to 85°C	-1.25		1.25	%
		VIN_K – SENSE_K = 5.5 mV, CL = VDD (20% IIN _{FSR}), T _J = 0°C to 85°C	-5.5		5.5	%
		VIN_K – SENSE_K = 44 mV, CL = GND (80% IIN _{FSR}), T _J = 0°C to 85°C	-3.5		3.5	%
VIN	VIN accuracy	VIN = 48 V, T _J = 0°C to 85°C	-1		1	%
VOUT	VOUT accuracy	VOUT = 48 V, T _J = 0°C to 85°C	-1		1	%
VAUX	VAUX accuracy	VAUX = 2.8 V, T _J = 0°C to 85°C	-1.3		1.3	%
PIN _{ACC}	Input power accuracy	VIN = 48 V, VIN_K – SENSE_K = 22 mV, CL = VDD, T _J = 0°C to 85°C	-2.25		2.25	%
		VIN = 48 V, VIN_K – SENSE_K = 22 mV, LM5056A CL = VDD, T _J = 0°C to 85°C	-1.75		1.75	%
		VIN = 48 V, VIN_K – SENSE_K = 44 mV, CL = GND, T _J = 0°C to 85°C	-3.6		3.6	%
PMBus Pin Thresholds (SMBA, SDAI, SDAO, SCL)						
V _{IL}	SDAI, SCL input low voltage				0.9	V
V _{IH}	SDAI, SCL input high voltage		2.1			
V _{OL}	SDAO output low voltage	I _{SINK} = 3 mA			0.4	
I _{LEAK}	Input leakage current	SDAI, SMBA, SCL = 5 V			1	μA
CL Pin						
V _{IH}	Threshold voltage		3			V
I _{LEAK}	Input leakage current	CL = 5 V		10		μA

TYPICAL CHARACTERISTICS

Unless otherwise specified the following conditions apply: $T_J = 25^\circ\text{C}$, V_{IN} , V_{IN_K} , $SENSE$, and $OUT = 48\text{ V}$ and $V_{DD} = 5.0\text{ V}$. All graphs show junction temperature.

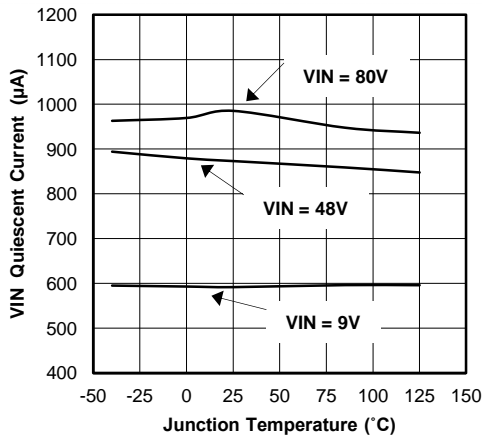

Figure 1. VIN Pin Current

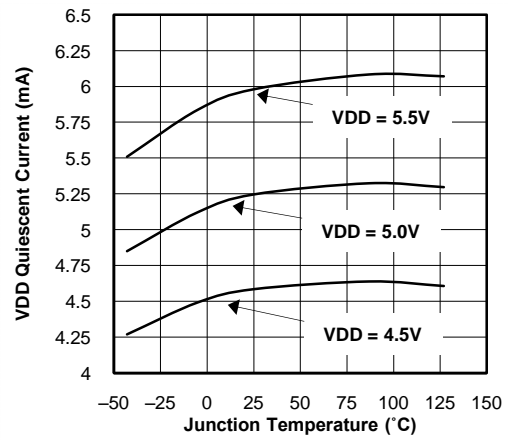

Figure 2. VDD Quiescent Current

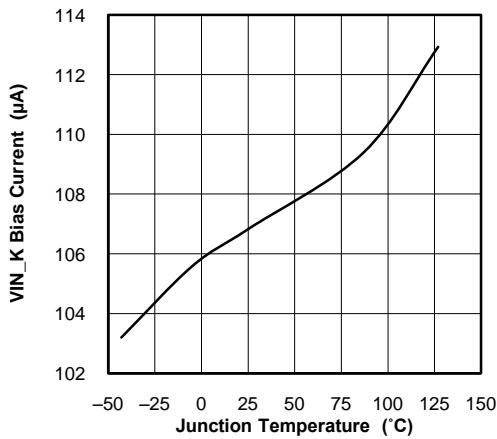

Figure 3. VIN_K Pin Current

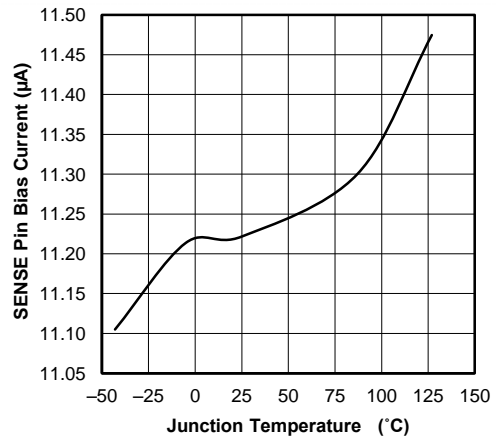

Figure 4. SENSE Pin Current

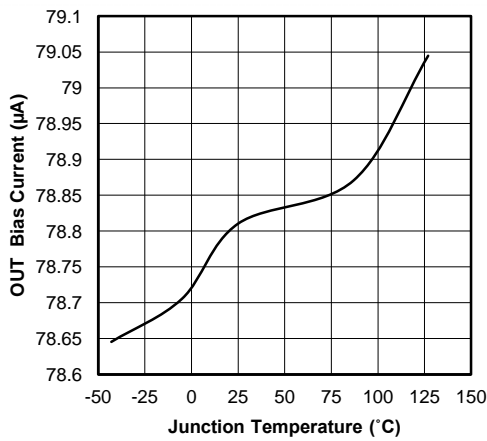

Figure 5. OUT Pin Current

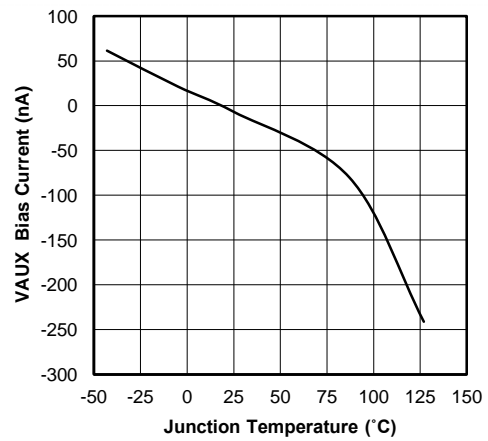

Figure 6. VAUX Pin Current (VAUX = 2.97 V)

TYPICAL CHARACTERISTICS (continued)

Unless otherwise specified the following conditions apply: $T_J = 25^\circ\text{C}$, V_{IN} , V_{IN_K} , $SENSE$, and $OUT = 48\text{ V}$ and $V_{DD} = 5.0\text{ V}$. All graphs show junction temperature.

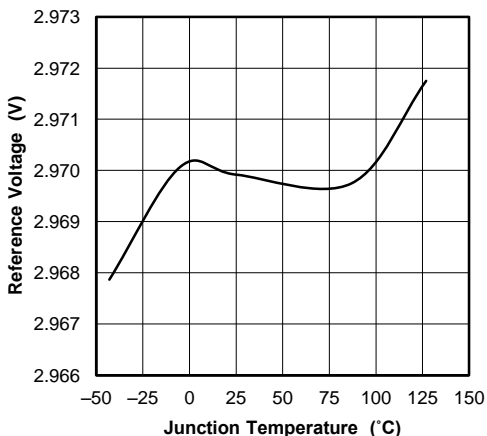

Figure 7. VREF Voltage

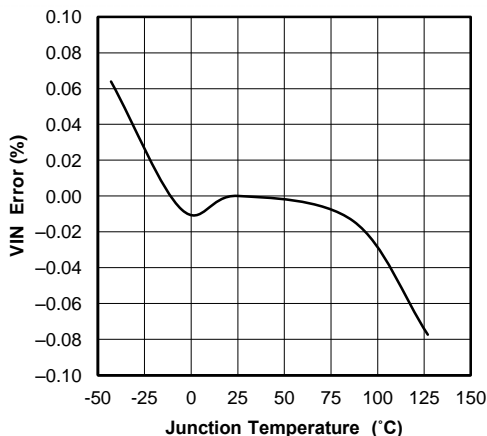

Figure 8. VIN Measurement Error

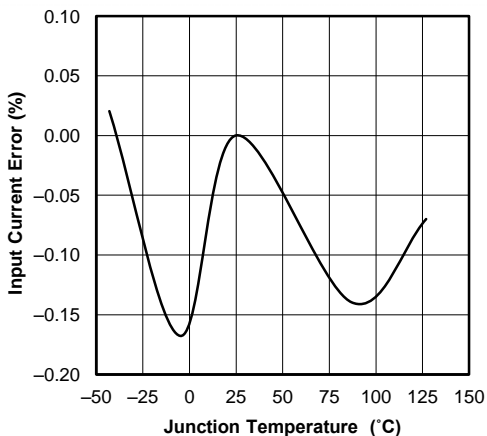

Figure 9. IIN Measurement Accuracy ($V_{IN_K} - SENSE = 22\text{ mV}$)

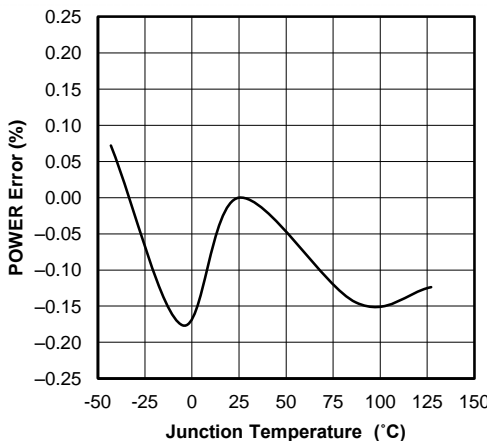

Figure 10. PIN Measurement Error ($V_{IN_K} - SENSE = 22\text{ mV}$)

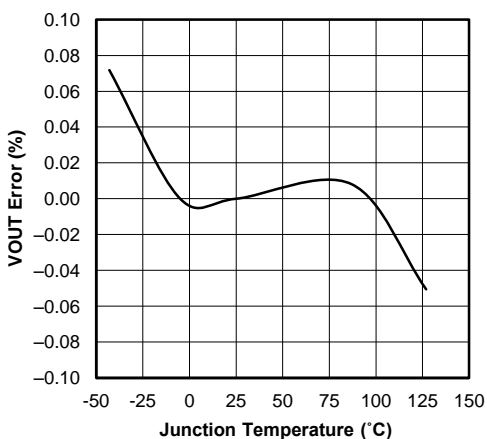

Figure 11. VOUT Measurement Error

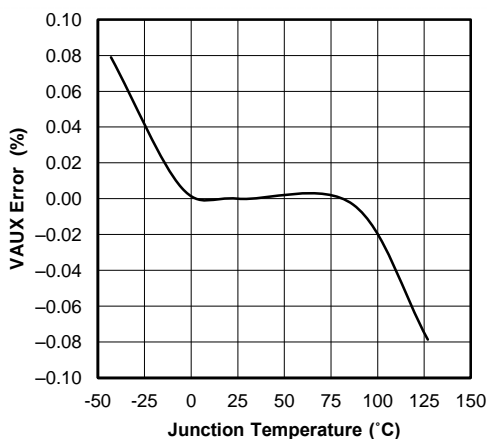
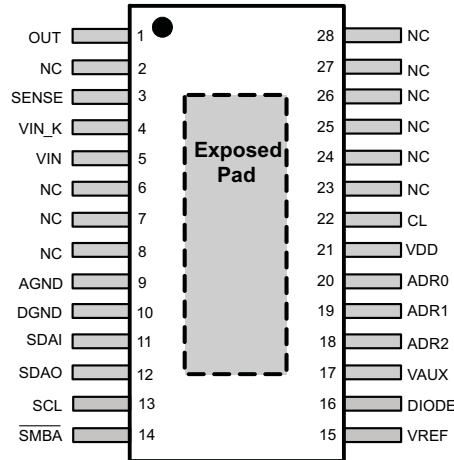

Figure 12. VAUX Measurement Error ($VAUX = 2.80\text{ V}$)

DEVICE INFORMATION

**HTSSOP Package
28 Pin
(Top View)**



TERMINAL FUNCTIONS

TERMINAL		I/O	DESCRIPTION
NAME	NO.		
Exposed Pad	Pad		Exposed pad of HTSSOP package. Solder to the ground plane to reduce thermal resistance.
OUT	1	I	Output voltage telemetry input. The OUT pin is an auxiliary high-voltage input to the ADC. Use this pin to measure the output voltage or other system voltages up to 80 V.
NC	2	-	No connect. Not bonded to the die. Can be connected to the ground plane.
SENSE	3	I	Negative input to the current sense amplifier. The voltage across the current sense resistor (R_S) is measured from VIN_K to SENSE.
VIN_K	4	I	Positive input to the current sense amplifier. The voltage across the current sense resistor (R_S) is measured from VIN_K to SENSE.
VIN	5	I	Positive supply input. VIN is the input supply connection for the device. The input voltage is measured between this pin and AGND. A small bypass capacitor can be connected from VIN to AGND/DGND in noisy environments.
NC	6	-	No connect. Not bonded to the die. Connect to the ground plane.
NC	7	-	No connect. Not bonded to the die. Connect to the ground plane.
NC	8	-	No connect. Not bonded to the die. Connect to the ground plane.
AGND	9	-	Analog ground. Connect analog ground to digital ground and then to a quiet system ground. Be sure to avoid high current return paths.
DGND	10	-	Digital ground. Connect analog ground to digital ground and then to a clean system ground. Be sure to avoid high current return paths.
SDAI	11	I	SMBus data input. Data input pin for SMBus. Connect to SDAO if the application does not require unidirectional isolation devices.
SDAO	12	O	SMBus data output. Data output pin for SMBus. Connect to SDAI if the application does not require unidirectional isolation devices.
SCL	13	I	SMBus clock input. Clock pin for SMBus.
SMBA	14	O	SMBus alert line. Alert pin for SMBus, active low.
VREF	15	O	Internal voltage reference. Internally generated precision 2.97V voltage reference used for analog to digital conversion. Connect a 1 μ F capacitor from this pin to AGND for bypassing.
DIODE	16	O	External temperature diode pin. Connect DIODE to a diode-configured MMBT3904 NPN transistor for temperature monitoring. The diode return path should be closely coupled with AGND. A small bypass capacitance on the order of 1 nF is recommended for extra noise immunity.
VAUX	17	I	Auxiliary low voltage input. The Auxiliary pin allows voltage telemetry from an external source. Full scale input of 2.966 V.
ADR2	18	I	SMBUS address line 2. Tri-state address line. Should be connected to DGND, VDD, or left floating.

TERMINAL FUNCTIONS (continued)

TERMINAL		I/O	DESCRIPTION
NAME	NO.		
ADR1	19	I	SMBUS address line 1. Tri-state address line. Should be connected to DGND, VDD, or left floating.
ADR0	20	I	SMBUS address line 0. Tri-state address line. Should be connected to DGND, VDD, or left floating.
VDD	21	I	VDD input to internal digital circuitry. Provide a 5.0-V ($\pm 10\%$ allowable) voltage supply to VDD to power the internal digital circuitry. Connect a 1 μ F capacitor on this pin to AGND for bypassing.
CL	22	O	Current range select pin. Connecting this pin to VDD or DGND selects between a full-scale current sense voltage range of 27.0 mV and 54.4 mV respectively.
NC	23	-	Bonded to die for testing purposes. Connect to the ground plane.
NC	24	-	Bonded to die for testing purposes. Connect to the ground plane.
NC	25	-	No connect. Not bonded to the die. Connect to the ground plane.
NC	26	-	No connect. Not bonded to the die. Connect to the ground plane.
NC	27	-	No connect. Not bonded to the die. Connect to the ground plane.
NC	28	-	No connect. Not bonded to the die. Connect to the ground plane.

FUNCTIONAL BLOCK DIAGRAM

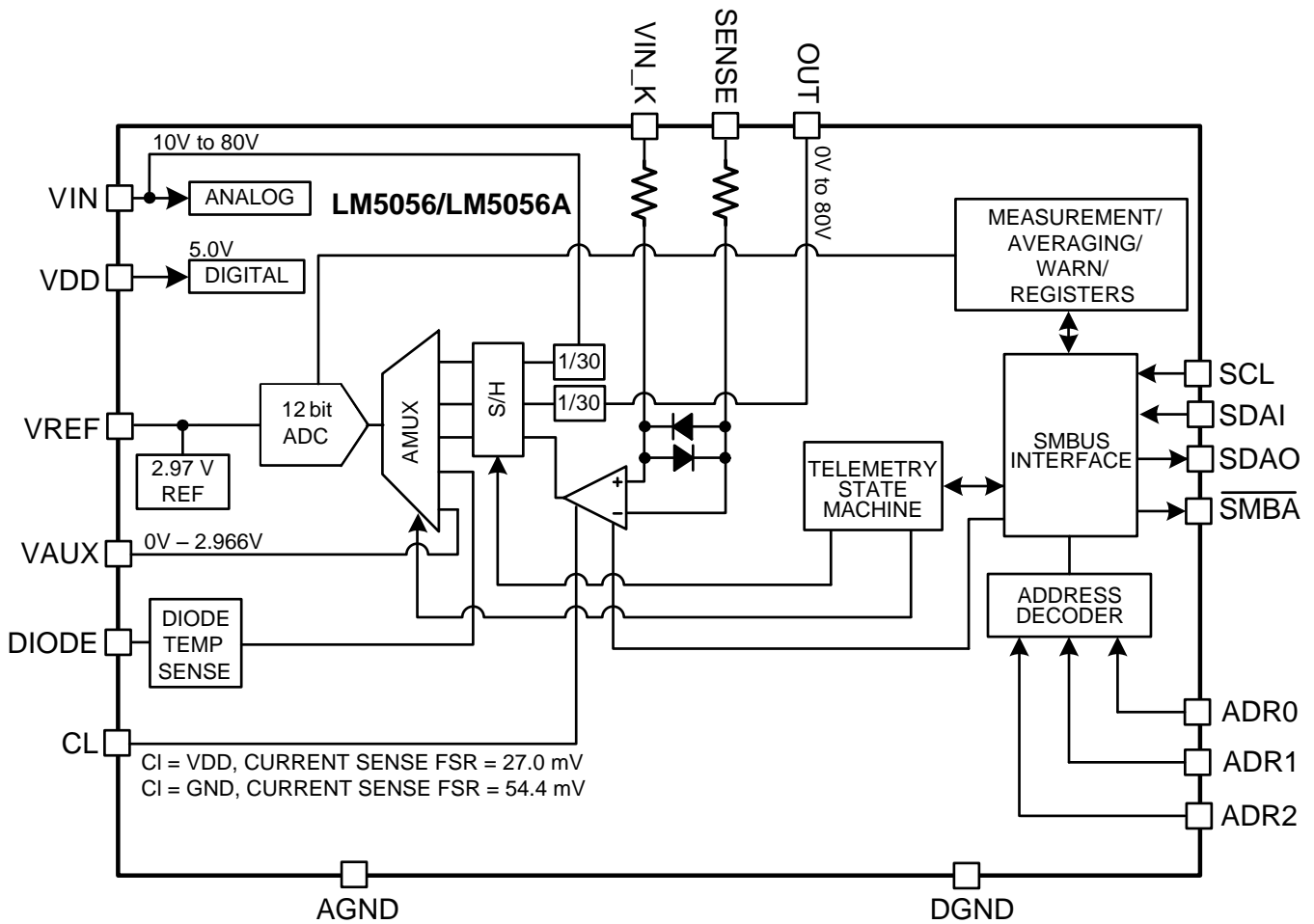

FUNCTIONAL DESCRIPTION

The LM5056/LM5056A provides intelligent monitoring of the input voltage, output voltage, input current, input power, temperature, and an auxiliary input. The LM5056/LM5056A also provides a peak capture of the input power and programmable hardware averaging of the input voltage, current, power, temperature, and output voltage. Warning thresholds which trigger the SMBA pin may be programmed for input voltage, current, power, output voltage, and temperature via the PMBus interface.

Powering The LM5056/LM5056A

The LM5056/LM5056A is enabled by increasing the input voltage on VIN above the POR_{EN} threshold voltage, typically 8.7 V. There exists a VDD power on reset (VDD_{POR}) threshold on VDD of 3.8 V. The VDD_{POR} threshold must be surpassed to ensure proper telemetry readings. VDD must be powered externally by a 5 V power supply with an allowable tolerance of $\pm 10\%$. The SMBus address of the LM5056/LM5056A is captured based on the states of the ADR0, ADR1, and ADR2 pins (GND, NC, VDD) during turn on and is latched into a volatile register once VDD has exceeded its POR threshold of 3.8 V. Reassigning or postponing the address capture is accomplished by holding the VREF pin to AGND. Pulling the VREF pin low also resets the logic and erases the volatile memory of the LM5056/LM5056A. Once released, the VREF pin charges up to its final value and the address is latched into a volatile register when the voltage at the VREF exceeds 2.55 V.

VDD

As mentioned in the previous paragraph, the LM5056/LM5056A VDD pin must be externally powered by a 5.0 V, $\pm 10\%$ supply. The required current is typically 6.1 mA. The pull-up voltage for the CL, ADR2, ADR1 and ADR0 pins should be the same as the voltage applied to VDD if they are to be tied high. It may also be used as the pull-up supply for the SMBus signals (SDA/O, SCL, SMBA). It is recommended to connect a ceramic bypass capacitance having a value of 1 μ F or greater as close to the VDD pin as the PCB layout allows.

Remote Temperature Sensing

The LM5056/LM5056A is designed to measure temperature remotely using an MMBT3904 NPN transistor. The base and collector of the MMBT3904 should be connected to the DIODE pin and the emitter to the LM5056/LM5056A AGND. Place the MMBT3904 near the device that requires temperature sensing. The temperature is measured by means of a change in the diode voltage in response to a step in current supplied by the DIODE pin. The DIODE pin sources a constant 9.4 μ A but pulses 250 μ A once every millisecond in order to measure the diode temperature. Care must be taken in the PCB layout to keep the parasitic resistance between the DIODE pin and the MMBT3904 low as to not degrade the measurement. Additionally, a small 1 nF bypass capacitor should be placed in parallel with the MMBT3904 to reduce the effects of noise. The temperature can be read using the `READ_TEMPERATURE_1` PMBus command (8Dh). The default limits of the LM5056/LM5056A causes SMBA pin to be pulled low if the measured temperature exceeds 150°C. These thresholds can be reprogrammed via the PMBus interface using the `OT_WARN_LIMIT` (51h) and `OT_FAULT_LIMIT` (4Fh) commands. If the temperature measurement and protection capability of the LM5056/LM5056A are not used, the DIODE pin should be connected to the ground plane.

Erroneous temperature measurements may result when the device input voltage is below the minimum operating voltage (10 V), due to VREF dropping out below the nominal voltage (2.97 V).

APPLICATION INFORMATION

DESIGN-IN PROCEDURE

Refer to [Figure 13](#) for the Typical Application Circuit diagram. The following is the step-by-step procedure for hardware design of the LM5056/LM5056A. This procedure refers to section numbers that provide detailed information on the following design steps. The recommended design-in procedure is as follows:

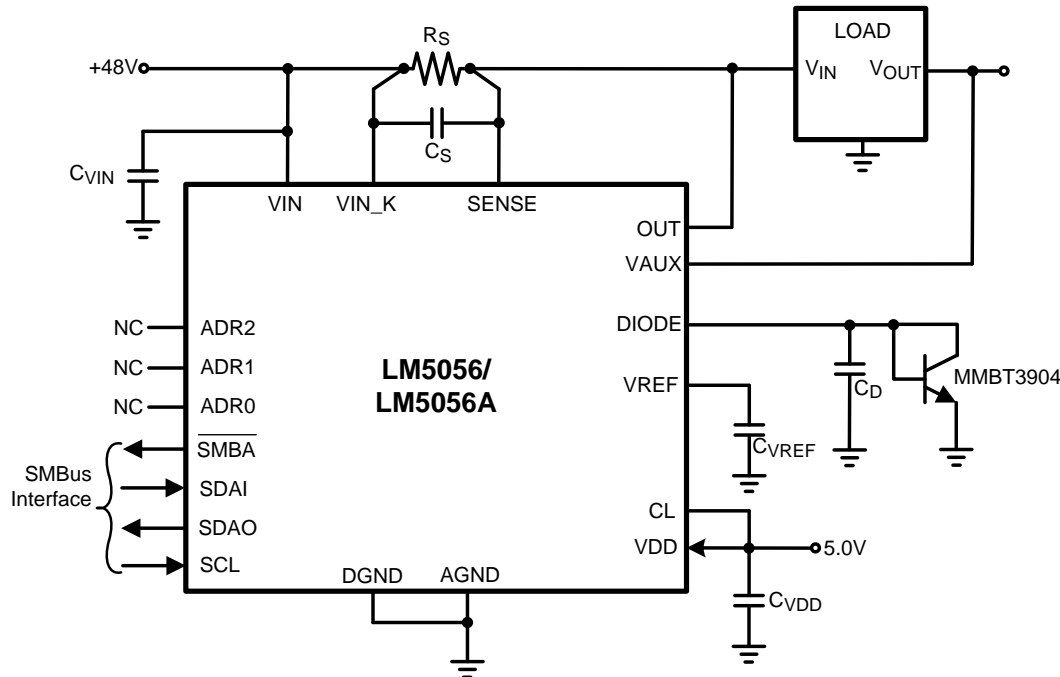

Figure 13. Typical Application Circuit

CURRENT Range (Selecting R_S)

The LM5056/LM5056A monitors the input current by measuring the voltage across the sense resistor (R_S), connected from V_{IN_K} to $SENSE$. The required resistor value is calculated from:

$$R_S = \frac{V_S}{I_{FS}}$$

where

- I_{FS} is the expected full scale current and V_S is the current sense voltage range based on the current select range setting (CL). (1)

If the voltage across R_S reaches V_S , the current measurement reaches the full-scale measurement. As mentioned before, it is important to limit the current to the full-scale reading. While there is internal circuitry intended to maintain the integrity of the other readings in the telemetry, the ADC and MUX are shared so overranging an input may compromise the integrity of the other readings.

V_S can be set to either 27.0 mV or 54.4 mV through software commands or the CL pin. This setting defaults to the sense voltage set at the CL pin during start-up. The value can be set via the PMBus with the `DEVICE_SETUP` (D9h) command, which defaults to the 27.0 mV setting. Once the full scale current, I_{FS} is known and the V_S range is chosen, the sense resistor can be calculated. The maximum load current in normal operation can be used to determine the required power rating for the sense resistor R_S .

Connections from R_S to the LM5056/LM5056A should be made using Kelvin techniques. In the suggested layout of [Figure 14](#) the small pads at the lower corners of the sense resistor connect only to the sense resistor terminals, and not to the traces carrying the high current. With this technique, only the voltage across the sense resistor is applied to V_{IN_K} and $SENSE$, eliminating the voltage drop across the high-current solder connections.

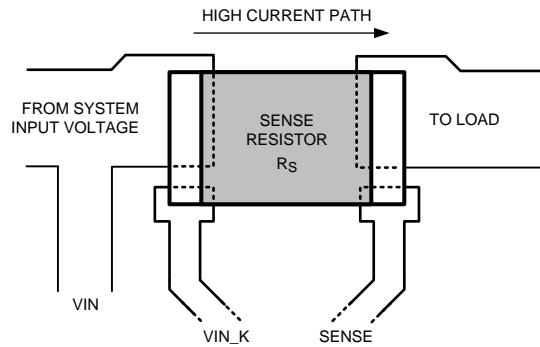

Figure 14. Sense Resistor Connections, Edge Sensed

If the PCB layout and resistor pads allow for it, the connection shown in Figure 15 gives optimal kelvin sensing performance.

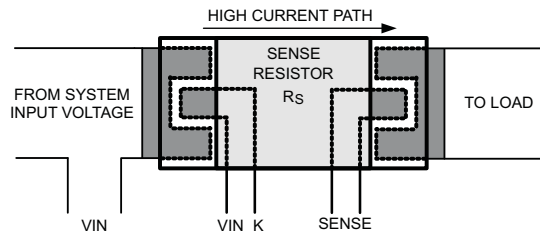

Figure 15. Sense Resistor Connections, Centered Sensed

C_{VIN} , C_D , C_{VREF} , C_S , and C_{VDD}

Using ceramic bypass capacitors can improve performance in noise heavy environments. Not every pin of the LM5056/LM5056A is the same when it comes to placing bypass capacitors.

- C_{VIN} : This capacitor is not required but can improve VIN telemetry performance in noisy situations. Typical values for the VIN bypass capacitor can range from 1 nF to 100 nF to effectively reduce input noise. The voltage on C_{VIN} is high, so a 100 V or higher voltage capacitor will work.
- C_D : The C_D capacitor is recommended if the diode is placed far from the LM5056/LM5056A DIODE pin. Too large of a capacitance will corrupt the voltage waveform across the diode used to measure the absolute temperature. A typical value of capacitance for C_D is 1 nF. The voltage on C_D is low, so a 6.3 V or higher voltage capacitor will work.
- C_{VREF} : C_{VREF} is required since it is placed on the output of the internal voltage reference. This capacitor should be a 1 μ F ceramic. The voltage on C_{VREF} is low, so a 6.3 V or higher voltage capacitor will work.
- C_S : The current sense amplifier is designed to amplify small voltages. Using a bypass capacitor across the current sense amplifier input pins (VIN_K and SENSE) will facilitate accurate current telemetry. Functional values of C_S can range from 10 nF to 1 μ F. The voltage on C_S is low, so a 6.3 V or higher voltage capacitor will work.
- C_{VDD} : C_{VDD} is required because it provides bypassing from the 5.0 V rail for the internal digital circuitry. This capacitor should be a 1- μ F ceramic. The voltage on C_{VDD} is low, so a 6.3 V or higher voltage capacitor will work.

PC Board Guidelines

The following guidelines should be followed when designing the PC board for the LM5056/LM5056A:

- Place a 1- μ F ceramic capacitor as close as possible to VREF pin and AGND.
- Place a 1- μ F ceramic capacitor as close as possible to VDD pin and AGND.
- Minimize the inductance between the VIN and VIN_K pins. There are anti-parallel diodes between these pins so any voltage greater than 0.3 V in either polarity causes significant current flow through the diodes, which can result in device failure. Do not place any resistors between these two nodes.
- Minimize the voltage between the VIN_K and SENSE pins. There are anti-parallel diodes between these pins so any voltage greater than 3.0 V in either polarity causes significant current flow through the diodes. Internal series resistors limit the current in these pins and provide a limited level of protection in the event of a voltage transient.
- The sense resistor (R_S) should be placed close to the LM5056/LM5056A. Connect R_S using the Kelvin techniques shown in [Figure 14](#) or [Figure 15](#).
- The high-current path from the board's input to the load and the return path, should be parallel and close to each other to minimize loop inductance.
- The AGND and DGND connections should be connected at the pins of the device. The return connections for the various components around the LM5056/LM5056A should be connected directly to each other, and to the LM5056/LM5056A's DGND and AGND pin connections, and then connected to the system ground at one point. Do not connect the various component return pads to each other through the high current ground line.

Applications Circuit

Power, voltage, current, fault, temperature, and LED luminosity telemetry for LED street lamps.

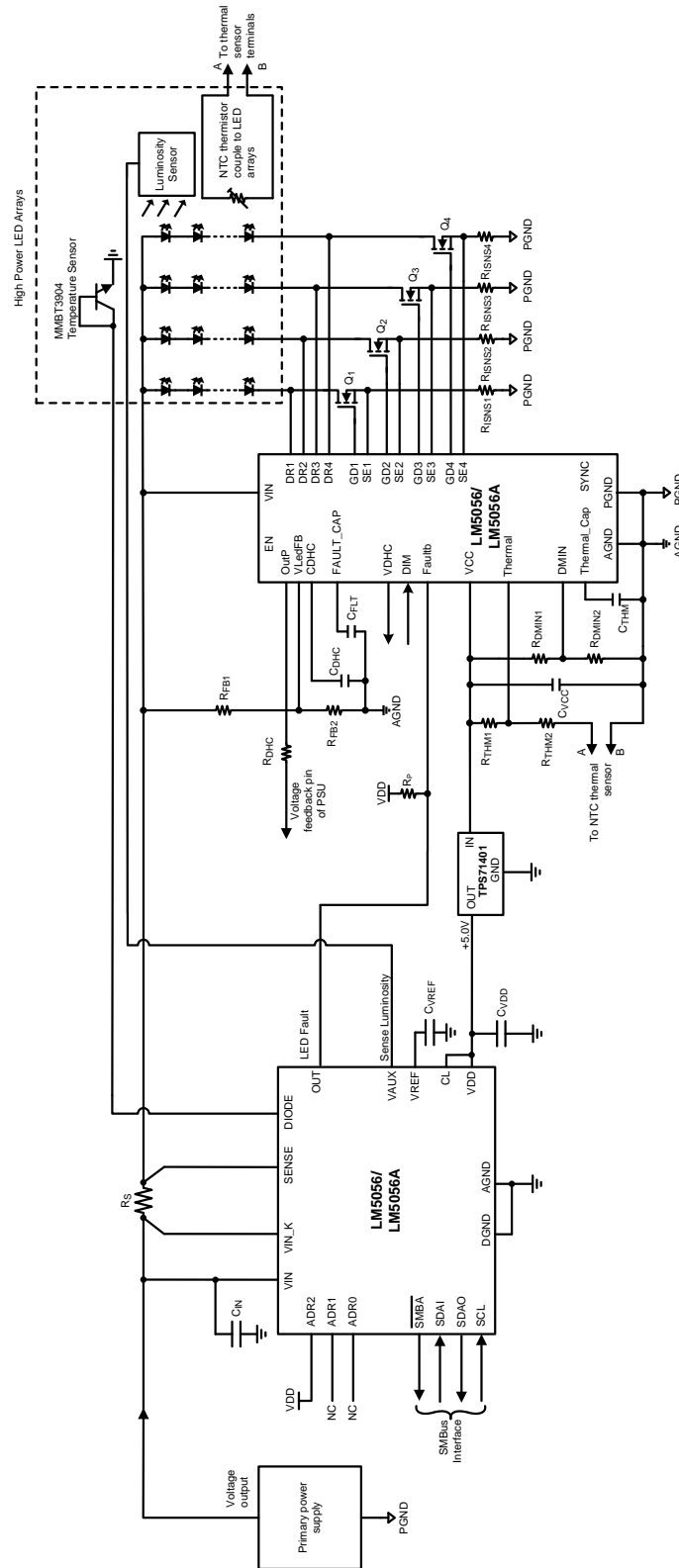

Figure 16. LED Street Lamp Telemetry

Applications Circuit

Telemetry of input rail and 5-V bias rail output current and voltage.

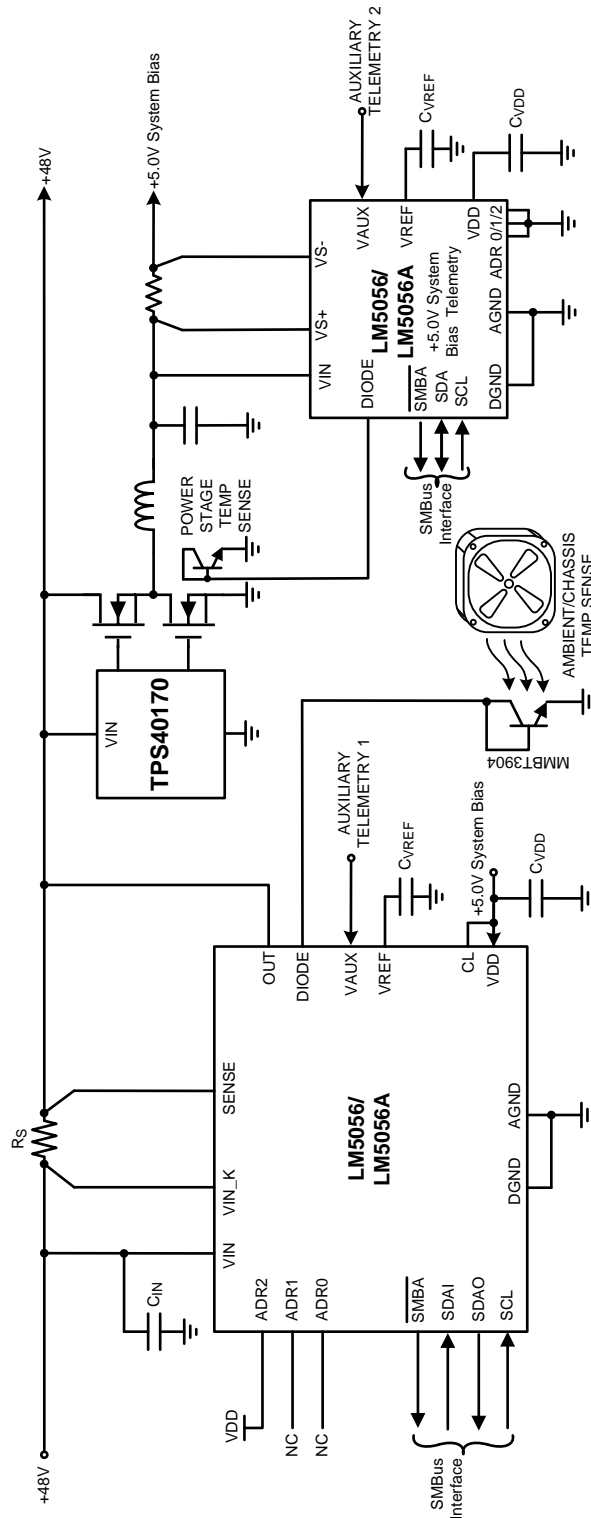

Figure 17. 48-V Input Rail and 5-V Bias Rail Telemetry

PMBus™ Command Support

The device features an SMBus interface that allows the use of PMBus commands to set warn levels, error masks, and get telemetry on VIN, VOUT, IIN, VAUX, and PIN. The supported PMBus commands are shown in Table 1.

Table 1. PMBus™ Command Support

CODE	NAME	FUNCTION	R/W	NUMBER OF DATA BYTES	DEFAULT VALUE
03h	CLEAR_FAULTS	Clears the status registers and re-arms the black box registers for updating.	Send Byte	0	
19h	CAPABILITY	Retrieves the device capability.	R	1	B0h
43h	VOUT_UV_WARN_LIMIT	Retrieves or stores output under-voltage, warn-limit threshold.	R and W	2	0000h
4Fh	OT_FAULT_LIMIT	Retrieves or stores over-temperature, fault-limit threshold.	R and W	2	0960h (150°C)
51h	OT_WARN_LIMIT	Retrieves or stores over-temperature, warn-limit threshold.	R and W	2	07D0h (125°C)
57h	VIN_OV_WARN_LIMIT	Retrieves or stores input over-voltage, warn-limit threshold.	R and W	2	0FFFh
58h	VIN_UV_WARN_LIMIT	Retrieves or stores input under-voltage, warn-limit threshold.	R and W	2	0000h
78h	STATUS_BYTE	Retrieves information about the parts operating status.	R	1	01h
79h	STATUS_WORD	Retrieves information about the parts operating status.	R	2	1801h
7Ah	STATUS_VOUT	Retrieves information about output voltage status.	R	1	00h
7Ch	STATUS_INPUT	Retrieves information about input status.	R	1	00h
7Dh	STATUS_TEMPERATURE	Retrieves information about temperature status.	R	1	00h
7Eh	STATUS_CML	Retrieves information about communications status.	R	1	00h
80h	STATUS_MFR_SPECIFIC	Retrieves information about default status.	R	1	10h
88h	READ_VIN	Retrieves input voltage measurement.	R	2	0000h
8Bh	READ_VOUT	Retrieves output voltage measurement.	R	2	0000h
8Dh	READ_TEMPERATURE_1	Retrieves temperature measurement.	R	2	0190h
99h	MFR_ID	Retrieves manufacturer ID in ASCII characters (NSC).	R	3	4Eh 53h 43h
9Ah	MFR_MODEL	Retrieves Part number in ASCII characters. (LM5056/LM5056A/LM5056/LM5056AA).	R	8	4Ch 4Dh 35h 30h 35h 36h 00h 00h
9Bh	MFR_REVISION	Retrieves part revision letter and number in ASCII (e.g., AA).	R	2	41h 41h
D0h	MFR_SPECIFIC_00 MFR_READ_VAUX	Retrieves auxiliary voltage measurement.	R	2	0000h
D1h	MFR_SPECIFIC_01 MFR_READ_IIN	Retrieves input current measurement.	R	2	0000h
D2h	MFR_SPECIFIC_02 MFR_READ_PIN	Retrieves input power measurement.	R	2	0000h
D3h	MFR_SPECIFIC_03 MFR_IIN_OC_WARN_LIMIT	Retrieves or stores input-current-limit warn threshold.	R and W	2	0FFFh
D4h	MFR_SPECIFIC_04 MFR_PIN_OP_WARN_LIMIT	Retrieves or stores input-power-limit warn threshold.	R and W	2	0FFFh
D5h	MFR_SPECIFIC_05 MFR_READ_PIN_PEAK	Retrieves measured peak-input-power measurement.	R	2	0000h

Table 1. PMBus™ Command Support (continued)

CODE	NAME	FUNCTION	R/W	NUMBER OF DATA BYTES	DEFAULT VALUE
D6h	MFR_SPECIFIC_06 MFR_CLEAR_PIN_PEAK	Resets the contents of the peak-input-power register to zero.	Send Byte	0	
D8h	MFR_SPECIFIC_08 MFR_ALERT_MASK	Retrieves or stores user $\overline{\text{SMBA}}$ fault mask.	R and W	2	0800h
D9h	MFR_SPECIFIC_09 MFR_DEVICE_SETUP	Retrieves or stores information about current sense gain setting.	R and W	1	0000h
DAh	MFR_SPECIFIC_10 MFR_BLOCK_READ	Retrieves most recent diagnostic and telemetry information in a single transaction.	R	12	0880h 0000h 0000h 0000h 0000h
DBh	MFR_SPECIFIC_11 MFR_SAMPLES_FOR_AVG	Exponent value AVGN for number of samples to be averaged ($N = 2^{\text{AVGN}}$), range = 00h to 0Ch .	R and W	1	00h
DCh	MFR_SPECIFIC_12 MFR_READ_AVG_VIN	Retrieves averaged input-voltage measurement.	R	2	0000h
DDh	MFR_SPECIFIC_13 MFR_READ_AVG_VOUT	Retrieves averaged output-voltage measurement.	R	2	0000h
DEh	MFR_SPECIFIC_14 MFR_READ_AVG_IIN	Retrieves averaged input-current measurement.	R	2	0000h
DFh	MFR_SPECIFIC_15 MFR_READ_AVG_PIN	Retrieves averaged input-power measurement.	R	2	0000h
E0h	MFR_SPECIFIC_16 MFR_BLACK_BOX_READ	Captures diagnostic and telemetry information which are latched when the first $\overline{\text{SMBA}}$ event after faults are cleared.	R	12	0000h 0000h 0000h 0000h 0000h
E1h	MFR_SPECIFIC_17 MFR_DIAGNOSTIC_WORD_READ	Manufacturer-specific parallel of the STATUS_WORD to convey all FAULT and WARN data in a single transaction.	R	2	0880h
E2h	MFR_SPECIFIC_18 MFR_AVG_BLOCK_READ	Retrieves most recent average telemetry and diagnostic information in a single transaction.	R	12	0000h 0000h 0000h 0000h 0000h

Standard PMBus Commands

CLEAR_FAULTS (03h)

The CLEAR_FAULTS command is a standard PMBus command that resets all stored warning and fault flags and the $\overline{\text{SMBA}}$ signal. If a fault or warning condition still exists when the CLEAR_FAULTS command is issued, the $\overline{\text{SMBA}}$ signal may not clear or will reassert almost immediately. This command uses the PMBus send byte protocol.

CAPABILITY (19h)

The CAPABILITY command is a standard PMBus command that returns information about the PMBus functions supported by the LM5056/LM5056A/LM5056/LM5056AA. This command is read with the PMBus read byte protocol.

Table 2. CAPABILITY Register

VALUE	MEANING	DEFAULT
B0h	Supports packet error check, 400 Kbits/s, supports SMBus alert	B0h

VOUT_UV_WARN_LIMIT (58h)

The VOUT_UV_WARN_LIMIT command is a standard PMBus command that allows configuring or reading the threshold for the VOUT under-voltage warning detection. Reading and writing to this register should use the coefficients shown in the [Table 39](#). Accesses to this command should use the PMBus read or write word protocol. If the measured value of VOUT falls below the value in this register, VOUT under-voltage warn flags are set and the $\overline{\text{SMBA}}$ signal is asserted.

Table 3. VOUT_UV_WARN_LIMIT Register

VALUE	MEANING	DEFAULT
0001h – 0FFFh	VOUT under-voltage warning detection threshold	0000h (disabled)
0000h	VOUT under-voltage warning disabled	n/a

OT_FAULT_LIMIT (4Fh)

The OT_FAULT_LIMIT command is a standard PMBus command that allows configuring or reading the threshold for the over-temperature fault detection. Reading and writing to this register should use the coefficients shown in the [Table 39](#). Accesses to this command should use the PMBus read or write word protocol. If the measured temperature exceeds this value, an over-temperature fault is triggered and the $\overline{\text{SMBA}}$ signal is asserted. After the measured temperature falls below the value in this register, the CLEAR_FAULTS command (03h) should be sent to de-assert the $\overline{\text{SMBA}}$ signal. A single temperature measurement is an average of 16 round-robin cycles; therefore, the minimum temperature fault detection time is 16 ms.

Table 4. OT_FAULT_LIMIT Register

VALUE	MEANING	DEFAULT
0000h – 0FFEh	Over-temperature fault threshold value	0960h (150°C)
0FFFh	Over-temperature fault detection disabled	n/a

OT_WARN_LIMIT (51h)

The OT_WARN_LIMIT command is a standard PMBus command that allows configuring or reading the threshold for the over-temperature warning detection. Reading and writing to this register should use the coefficients shown in the [Table 39](#). Accesses to this command should use the PMBus read or write word protocol. If the measured temperature exceeds this value, an over-temperature warning is triggered and the over-temperature warn flags set in the respective registers and the $\overline{\text{SMBA}}$ signal asserted. A single temperature measurement is an average of 16 round-robin cycles; therefore, the minimum temperature warn detection time is 16 ms.

Table 5. OT_WARN_LIMIT Register

VALUE	MEANING	DEFAULT
0000h – 0FFh	Over-temperature warn threshold value	07D0h (125°C)
0FFh	Over-temperature warn detection disabled	n/a

VIN_OV_WARN_LIMIT (57h)

The VIN_OV_WARN_LIMIT command is a standard PMBus command that allows configuring or reading the threshold for the VIN over-voltage warning detection. Reading and writing to this register should use the coefficients shown in the [Table 39](#) Table. Accesses to this command should use the PMBus read or write word protocol. If the measured value of VIN rises above the value in this register, VIN over-voltage warn flags are set in the respective registers and the $\overline{\text{SMBA}}$ signal is asserted.

Table 6. VIN_OV_WARN_LIMIT Register

VALUE	MEANING	DEFAULT
0000h – 0FFh	VIN Over-voltage warning detection threshold	0FFh (disabled)
0FFh	VIN Over-voltage warning disabled	n/a

VIN_UV_WARN_LIMIT (58h)

The VIN_UV_WARN_LIMIT command is a standard PMBus command that allows configuring or reading the threshold for the VIN under-voltage warning detection. Reading and writing to this register should use the coefficients shown in the [Table 39](#). Accesses to this command should use the PMBus read or write word protocol. If the measured value of VIN falls below the value in this register, VIN under-voltage warn flags are set in the respective register, and the $\overline{\text{SMBA}}$ signal is asserted.

Table 7. VIN_UV_WARN_LIMIT Register

VALUE	MEANING	DEFAULT
0001h – 0FFFh	VIN under-voltage warning detection threshold	0000h (disabled)
0000h	VIN under-voltage warning disabled	n/a

STATUS_BYTE (78h)

The STATUS_BYTE is a standard PMBus command that returns the value of a number of flags indicating the state of the LM5056/LM5056A. Accesses to this command should use the PMBus read byte protocol. To clear bits in this register, the underlying fault should be removed on the system and a CLEAR_FAULTS command issued.

Table 8. STATUS_BYTE Definitions

BIT	NAME	MEANING	DEFAULT
7	BUSY	Not supported, always 0	0
6	OFF	Not supported, always 0	0
5	VOUT_OV	Not supported, always 0	0
4	IOUT_OC	Not supported, always 0	0
3	VIN_UV	An input under-voltage fault has occurred	0
2	TEMPERATURE	A temperature fault or warning has occurred	0
1	CML	A communication fault has occurred	0

Table 8. STATUS_BYTE Definitions (continued)

BIT	NAME	MEANING	DEFAULT
0	None of the above	Not supported, always 1	1

STATUS_WORD (79h)

The STATUS_WORD command is a standard PMBus command that returns the value of a number of flags indicating the state of the LM5056/LM5056A. Accesses to this command should use the PMBus read word protocol. To clear bits in this register, the underlying fault should be removed and a CLEAR_FAULTS command issued.

Table 9. STATUS_WORD Definitions

BIT	NAME	MEANING	DEFAULT
15	VOUT	An output voltage warning has occurred	0
14	IOUT/POUT	Not supported, always 0	0
13	INPUT	Not supported, always 0	0
12	MFR	A manufacturer specific fault or warning has occurred	1
11	POWER GOOD	Not supported, always 1	1
10	FANS	Not supported, always 0	0
9	OTHER	Not supported, always 0	0
8	UNKNOWN	Not supported, always 0	0
7	BUSY	Not supported, always 0	0
6	OFF	Not supported, always 0	0
5	VOUT OV	Not supported, always 0	0
4	IOUT OC	Not supported, always 0	0
3	VIN UV	Not supported, always 0	0
2	TEMPERATURE	A temperature fault or warning has occurred	0
1	CML	A communication fault has occurred	0
0	None of the above	Not supported, always 1	1

STATUS_VOUT (7Ah)

The STATUS_VOUT command is a standard PMBus command that returns the value of the VOUT under-voltage warn flag. Accesses to this command should use the PMBus read byte protocol. To clear bits in this register, the underlying fault should be cleared and a CLEAR_FAULTS command issued.

Table 10. STATUS_VOUT Definitions

BIT	NAME	MEANING	DEFAULT
7	VOUT OV fault	Not supported, always 0	0
6	VOUT OV warn	Not supported, always 0	0
5	VOUT UV warn	A VOUT under-voltage warning has occurred	0
4	VOUT UV fault	Not supported, always 0	0
3	VOUT max	Not supported, always 0	0
2	TON max fault	Not supported, always 0	0
1	TOFF max fault	Not supported, always 0	0
0	VOUT tracking error	Not supported, always 0	0

STATUS_INPUT (7Ch)

The STATUS_INPUT command is a standard PMBus command that returns the value of a number of flags related to input voltage, current, and power. Accesses to this command should use the PMBus read byte protocol. To clear bits in this register, the underlying fault should be cleared and a CLEAR_FAULTS command issued.

Table 11. STATUS_INPUT Definitions

BIT	NAME	MEANING	DEFAULT
7	VIN OV Fault	Not supported, always 0	0
6	VIN OV Warn	A VIN over-voltage warning has occurred	0
5	VIN UV Warn	A VIN under-voltage warning has occurred	0
4	VIN UV Fault	Not supported, always 0	0
3	Insufficient voltage	Not supported, always 0	0
2	IIN OC Fault	Not supported, always 0	0
1	IIN OC Warn	An IIN over-current warning has occurred	0
0	PIN OP Warn	A PIN over-power warning has occurred	0

STATUS_TEMPERATURE (7dh)

The STATUS_TEMPERATURE is a standard PMBus command that returns the value of the of a number of flags related to the temperature telemetry value. Accesses to this command should use the PMBus read byte protocol. To clear bits in this register, the underlying fault should be cleared and a CLEAR_FAULTS command issued.

Table 12. STATUS_TEMPERATURE Definitions

BIT	NAME	MEANING	DEFAULT
7	Over-temp fault	An over-temperature fault has occurred	0
6	Over-temp warn	An over-temperature warning has occurred	0
5	Under-temp warn	Not supported, always 0	0
4	Under-temp fault	Not supported, always 0	0
3	reserved	Not supported, always 0	0
2	reserved	Not supported, always 0	0
1	reserved	Not supported, always 0	0
0	reserved	Not supported, always 0	0

STATUS_CML (7Eh)

The STATUS_CML is a standard PMBus command that returns the value of a number of flags related to communication faults. Accesses to this command should use the PMBus read byte protocol. To clear bits in this register, a CLEAR_FAULTS command should be issued.

Table 13. STATUS_CML Definitions

BIT	NAME	DEFAULT
7	Invalid or unsupported command received	0
6	Invalid or unsupported data received	0
5	Packet Error Check failed	0
4	Not supported, always 0	0
3	Not supported, always 0	0
2	Not supported, always 0	0
1	Miscellaneous communications fault has occurred	0
0	Not supported, always 0	0

STATUS_MFR_SPECIFIC (80h)

The STATUS_MFR_SPECIFIC command is a standard PMBus command that contains manufacturer specific status information. Accesses to this command should use the PMBus read byte protocol. To clear bits in this register, the underlying fault should be removed and a CLEAR_FAULTS command should be issued.

Table 14. STATUS_MFR_SPECIFIC Definitions

BIT	NAME	DEFAULT
7	Not supported, always 0	0
6	Not supported, always 0	0
5	Not supported, always 0	0
4	Defaults loaded	1
3	Not supported, always 0	0
2	Not supported, always 0	0
1	Not supported, always 0	0
0	Not supported, always 0	0

READ_VIN (88h)

The READ_VIN command is a standard PMBus command that returns the 12-bit measured value of the input voltage (VIN to AGND). Reading this register should use the coefficients shown in the [Table 39](#). Accesses to this command should use the PMBus read word protocol. This value is also used internally for the VIN over and under-voltage warning detection.

Table 15. READ_VIN Register

VALUE	MEANING	DEFAULT
0h – 0FFFh	Measured value for VIN	0000h

READ_VOUT (8Bh)

The READ_VOUT command is a standard PMBus command that returns the 12-bit measured value of the output voltage. Reading this register should use the coefficients shown in the [Table 39](#) Table. Accesses to this command should use the PMBus read word protocol. This value is also used internally for the VOUT under-voltage warning detection.

Table 16. READ_VOUT Register

VALUE	MEANING	DEFAULT
0h – 0FFFh	Measured value for VOUT	0000h

READ_TEMPERATURE_1 (8Dh)

The READ_TEMPERATURE_1 command is a standard PMBus command that returns the signed value of the temperature measured by the external temperature sense diode. Reading this register should use the coefficients shown in the [Table 39](#). Accesses to this command should use the PMBus read word protocol. This value is also used internally for the over-temperature fault and warning detection. This data has a range of -256°C to 255°C after the coefficients are applied.

Table 17. READ_TEMPERATURE_1 Register

VALUE	MEANING	DEFAULT
0h – 0FFFh	Measured value for TEMPERATURE	0190h

MFR_ID (99h)

The MFR_ID command is a standard PMBus command that returns the identification of the manufacturer. To read the MFR_ID, use the PMBus block read protocol.

Table 18. MFR_ID Register

BYTE	NAME	VALUE
0	Number of bytes	03h
1	MFR ID-1	4Eh 'N'
2	MFR ID-2	53h 'S'
3	MFR ID-3	43h 'C'

MFR_MODEL (9Ah)

The MFR_MODEL command is a standard PMBus command that returns the part number of the chip. To read the MFR_MODEL, use the PMBus block read protocol.

Table 19. MFR_MODEL Register

BYTE	NAME	VALUE
0	Number of bytes	08h
1	MFR ID-1	4Ch 'L'
2	MFR ID-2	4Dh 'M'
3	MFR ID-3	35h '5'
4	MFR ID-4	30h '0'
5	MFR ID-5	35h '5'
6	MFR ID-6	36h '6'
7	MFR ID-7	00h
8	MFR ID-8	00h

MFR_REVISION (9Bh)

The MFR_REVISION command is a standard PMBus command that returns the revision level of the part. To read the MFR_REVISION, use the PMBus block read protocol.

Table 20. MFR_REVISION Register

BYTE	NAME	VALUE
0	Number of bytes	02h
1	MFR ID-1	41h 'A'
2	MFR ID-2	41h 'A'

Manufacturer Specific PMBus™ Commands

MFR_SPECIFIC_00: MFR_READ_VAUX (D0h)

The MFR_READ_VAUX command will report the 12-bit ADC measured auxiliary voltage. Voltages greater than or equal to 2.97 V to ground are reported at plus full scale (0FFFh). Voltages less than or equal to 0 V referenced to ground are reported as 0 (0000h). To read data from the MFR_READ_VAUX command, use the PMBus Read Word protocol.

Table 21. MFR_READ_VAUX Register

VALUE	MEANING	DEFAULT
0h – 0FFFh	Measured value for VAUX input	0000h

MFR_SPECIFIC_01: MFR_READ_IIN (D1h)

The MFR_READ_IIN command reports the 12-bit ADC measured current sense voltage. To read data from the MFR_READ_IIN command, use the PMBus Read Word protocol. Reading this register should use the coefficients shown in the [Table 39](#). Please see the section on coefficient calculations to calculate the values to use.

Table 22. MFR_READ_IIN Register

VALUE	MEANING	DEFAULT
0h – 0FFFh	Measured value for input current sense voltage	0000h

MFR_SPECIFIC_02: MFR_READ_PIN (D2h)

The MFR_READ_PIN command reports the upper 12 bits of the VIN x IIN product as measured by the 12-bit ADC. To read data from the MFR_READ_PIN command, use the PMBus Read Word protocol. Reading this register should use the coefficients shown in the [Table 39](#). Please see the section on coefficient calculations to calculate the values to use.

Table 23. MFR_READ_PIN Register

VALUE	MEANING	DEFAULT
0h – 0FFFh	Value for input current x input voltage	0000h

MFR_SPECIFIC_03: MFR_IIN_OC_WARN_LIMIT (D3h)

The MFR_IIN_OC_WARN_LIMIT PMBus command sets the input over-current warning threshold. In the event that the input current rises above the value set in this register, the IIN over-current flags are set in the respective registers and the \overline{SMBA} is asserted. To access the MFR_IIN_OC_WARN_LIMIT register, use the PMBus Read/Write Word protocol. Reading/writing to this register should use the coefficients shown in the [Table 39](#).

Table 24. MFR_IIN_OC_WARN_LIMIT Register

VALUE	MEANING	DEFAULT
0h – 0FFEh	Value for input over-current warn limit	0FFFh
0FFFh	Input over-current warning disabled	n/a

MFR_SPECIFIC_04: MFR_PIN_OP_WARN_LIMIT (D4h)

The MFR_PIN_OP_WARN_LIMIT PMBus command sets the input over-power warning threshold. In the event that the input power rises above the value set in this register, the PIN over-power flags are set in the respective registers and the SMBA is asserted. To access the MFR_PIN_OP_WARN_LIMIT register, use the PMBus Read/Write Word protocol. Reading/writing to this register should use the coefficients shown in the [Table 39](#).

Table 25. MFR_PIN_OPWARN_LIMIT Register

VALUE	MEANING	DEFAULT
0h – 0FFEh	Value for input over-power warn limit	0FFFh
0FFFh	Input over-power warning disabled	n/a

MFR_SPECIFIC_05: MFR_READ_PIN_PEAK (D5h)

The MFR_READ_PIN_PEAK command reports the maximum input power measured since a power-on reset or the last MFR_CLEAR_PIN_PEAK command. To access the MFR_READ_PIN_PEAK command, use the PMBus Read Word protocol. Use the [Table 39](#).

Table 26. MFR_READ_PIN_PEAK Register

VALUE	MEANING	DEFAULT
0h – 0FFEh	Maximum value for input current x input voltage since reset or last clear	0h

MFR_SPECIFIC_06: MFR_CLEAR_PIN_PEAK (D6h)

The MFR_CLEAR_PIN_PEAK command clears the MFR_PIN_PEAK register. This command uses the PMBus Send Byte protocol.

MFR_SPECIFIC_08: MFR_ALERT_MASK (D8h)

The MFR_ALERT_MASK command is used to mask the SMBA when a specific fault or warning has occurred. Each bit corresponds to one of the 8 different analog and digital faults or warnings that would normally result in an SMBA being asserted. When the corresponding bit is high, that condition will not cause the SMBA to be asserted. If that condition occurs, the registers where that condition is captured will still be updated (STATUS registers, DIAGNOSTIC_WORD) . This register is accessed with the PMBus Read and Write Word protocol.

Table 27. MFR_ALERT_MASK Definitions

BIT	NAME	DEFAULT
15	VOUT under-voltage warn	0
14	IIN limit warn	0
13	VIN under-voltage warn	0
12	VIN over-voltage warn	0
11	Not supported, always 0	0
10	Over-temperature warn	0
9	Not supported, always 0	0
8	Over-power warn	0
7	Not supported, always 0	0
6	Not supported, always 0	0
5	Not supported, always 0	0
4	Not supported, always 0	0
3	Not supported, always 0	0
2	Over-temperature fault	0
1	CML FAULT (communications fault)	0
0	Not supported, always 0	0

MFR_SPECIFIC_09: MFR_DEVICE_SETUP (D9h)

The MFR_DEVICE_SETUP command may be used to override pin settings to define operation of the LM5056/LM5056A under host control. This command is accessed with the PMBus read and write byte protocol.

Table 28. MFR_DEVICE_SETUP Byte Format

BIT	NAME	DEFAULT
7:5	Not supported, always 0	0
4	Current sense gain	(Default) 0 = High setting (54.4mV)
		1 = Low setting (27.0mV)
3	Not supported, always 0	0
2	Current sense gain select configuration	(Default) 0 = Use pin settings
		1 = Use SMBus settings
1	Unused	0
0	Unused	0

In order to configure the current sense gain via this register, it is necessary to set the Current Sense Gain Select Configuration bit (2) to 1 to enable the register to control the current sense gain and the Current Sense Gain bit (4) to select the desired setting. If the Current Sense Gain Select Configuration bit is not set, the pin setting is used.

NOTE

If the Current Sense Gain Select Configuration is changed, the samples for the telemetry averaging function will not be reset. It is recommended to allow a full averaging update period with the new Current Sense Gain before processing the averaged data.

The Current Sense Gain Select Configuration affects the coefficients used for the current and power measurements and warning registers.

MFR_SPECIFIC_10: MFR_BLOCK_READ (DAh)

The MFR_BLOCK_READ command concatenates the MFR_DIAGNOSTIC_WORD with input and output telemetry information (IIN, VOUT, VIN, PIN) as well as TEMPERATURE to capture all of the operating information of the LM5056/LM5056A in a single SMBus transaction. The block is 12 bytes long with telemetry information being sent out in the same manner as if an individual READ_XXX command had been issued (shown below). The contents of the MFR_BLOCK_READ register are updated every clock cycle (85 ns) as long as the SMBus interface is idle. MFR_BLOCK_READ also ensures that the VIN, VOUT, IIN and PIN measurements are all time-aligned. If separate commands are used, individual samples may not be time-aligned, because of the delay necessary for the communication protocol. The MFR_BLOCK_READ command is read via the PMBus block read protocol.

Table 29. MFR_BLOCK_READ Register Format

BYTE COUNT (ALWAYS 12)	(1 BYTE)
MFR_DIAGNOSTIC_WORD	(1 Word)
IIN_BLOCK	(1 Word)
VOUT_BLOCK	(1 Word)
VIN_BLOCK	(1 Word)
PIN_BLOCK	(1 Word)
TEMP_BLOCK	(1 Word)

MFR_SPECIFIC_11: MFR_SAMPLES_FOR_AVG (DBh)

The MFR_SAMPLES_FOR_AVG command is a manufacturer specific command for setting the number of samples used in computing the average values for IIN, VIN, VOUT, PIN. The decimal equivalent of the AVGN nibble is the power of two samples, (e.g. AVGN = 12 equates to N = 4096 samples used in computing the average). The LM5056/LM5056A supports average numbers of 1, 2, 4, 8, 16, 32, 64, 128, 256, 512, 1024, 2048, 4096. The MFR_SAMPLES_FOR_AVG number applies to average values of IIN, VIN, VOUT, PIN simultaneously. The LM5056/LM5056A uses simple averaging. This is accomplished by summing consecutive results up to the number programmed, then dividing by the number of samples. Averaging is calculated according to the following sequence:

$$Y = \frac{(X(N) + X(N-1) + \dots + X(0))}{N} \quad (2)$$

When the averaging has reached the end of a sequence (for example, 4096 samples are averaged), then a whole new sequence begins that requires the same number of samples (in this example, 4096) to be taken before the new average is ready.

Table 30. MFR_SAMPLES_FOR_AVG Register

AVGN	N = 2 ^{AVGN}	AVERAGING AND REGISTER UPDATE PERIOD (ms)
0000	1	1
0001	2	2
0010	4	4
0011	8	8
0100	16	16
0101	32	32
0110	64	64
0111	128	128
1000	256	256
1001	512	512
1010	1024	1024
1011	2048	2048
1100	4096	4096

NOTE

A change in the MFR_SAMPLES_FOR_AVG register are not reflected in the average telemetry measurements until the present averaging interval has completed. The default setting for AVGN is 0000, therefore, the average telemetry mirrors the instantaneous telemetry until a value higher than zero is programmed.

The MFR_SAMPLES_FOR_AVG register is accessed via the PMBus read and write byte protocol.

Table 31. MFR_SAMPLES_FOR_AVG Register

VALUE	MEANING	DEFAULT
0h – 0Ch	Exponent (AVGN) for number of samples to average over	00h

MFR_SPECIFIC_12: MFR_READ_AVG_VIN (DCh)

The MFR_READ_AVG_VIN command will report the 12-bit ADC measured input average voltage. If the data is not ready, the returned value is the previous averaged data. However, if there is no previously averaged data, the default value (0000h) is returned. This data is read with the PMBus Read Word protocol. This register should use the coefficients shown in the [Table 39](#).

Table 32. MFR_READ_AVG_VIN Register

VALUE	MEANING	DEFAULT
0h – 0FFFh	Average of measured values for input voltage	0000h

MFR_SPECIFIC_13: MFR_READ_AVG_VOUT (DDh)

The MFR_READ_AVG_VOUT command reports the 12-bit ADC measured current sense average voltage. The returned value is the default value (0000h) or previous data when the average data is not ready. This data is read with the PMBus Read Word protocol. This register should use the coefficients shown in the [Table 39](#).

Table 33. MFR_READ_AVG_VOUT Register

VALUE	MEANING	DEFAULT
0h – 0FFFh	Average of measured values for output voltage	0000h

MFR_SPECIFIC_14: MFR_READ_AVG_IIN (DEh)

The MFR_READ_AVG_IIN command reports the 12-bit ADC measured current sense average voltage. The returned value is the default value (0000h) or previous data when the average data is not ready. This data is read with the PMBus Read Word protocol. This register should use the coefficients shown in the [Table 39](#).

Table 34. MFR_READ_AVG_IIN Register

VALUE	MEANING	DEFAULT
0h – 0FFFh	Average of measured values for current sense voltage	0000h

MFR_SPECIFIC_15: MFR_READ_AVG_PIN

The MFR_READ_AVG_PIN command reports the upper 12-bits of the average VIN x IIN product as measured by the 12-bit ADC. Read the default value (0000h) or previous data when the average data is not ready. This data is read with the PMBus Read Word protocol. This register should use the coefficients shown in the [Table 39](#).

Table 35. TABLE 35. MFR_READ_AVG_PIN Register

VALUE	MEANING	DEFAULT
0h – 0FFFh	Average of measured value for input voltage x input current sense voltage	0000h

MFR_SPECIFIC_16: MFR_BLACK_BOX_READ (E0h)

The MFR_BLACK_BOX_READ command retrieves the MFR_BLOCK_READ data which was latched in at the first assertion of SMBA by the LM5056/LM5056A. It is re-armed with the CLEAR_FAULTS command. It is the same format as the MFR_BLOCK_READ registers, the only difference being that its contents are updated with the SMBA edge rather than the internal clock edge. This command is read with the PMBus Block Read protocol.

MFR_SPECIFIC_17: MFR_READ_DIAGNOSTIC_WORD (E1h)

The MFR_READ_DIAGNOSTIC_WORD PMBus command reports all of the LM5056/LM5056A faults and warnings in a single read operation. The standard response to the assertion of the SMBA signal of issuing multiple read requests to various status registers can be replaced by a single word read to the MFR_DIAGNOSTIC_WORD register. The MFR_READ_DIAGNOSTIC_WORD command should be read with the PMBus Read Word protocol. The MFR_READ_DIAGNOSTIC_WORD is also returned in the MFR_BLOCK_READ, MFR_BLACK_BOX_READ, and MFR_AVG_BLOCK_READ operations.

Table 36. MFR_DIAGNOSTIC_WORD Format

BIT	MEANING	DEFAULT
15	VOUT under-voltage warn	0
14	Over-current warn or over-power warn	0
13	VIN under-voltage warn	0
12	VIN over-voltage warn	0
11	Not supported, always 1	1
10	Over-temperature warn	0
9	Not supported, always 0	0
8	Not supported, always 0	0
7	CONFIG_PRESET	1
6	Not supported, always 0	0
5	Not supported, always 0	0
4	Not supported, always 0	0
3	Not supported, always 0	0
2	Not supported, always 0	0
1	CML_FAULT	0
0	Not supported, always 0	0

MFR_SPECIFIC_18: MFR_AVG_BLOCK_READ (E2h)

The MFR_AVG_BLOCK_READ command concatenates the MFR_DIAGNOSTIC_WORD with input and output average telemetry information (IIN, VOUT, VIN, PIN) as well as temperature to capture all of the operating information of the part in a single PMBus transaction. The block is 12 bytes long with telemetry information being sent out in the same manner as if an individual READ_AVG_XXX command had been issued (shown below). MFR_AVG_BLOCK_READ also ensures that the VIN, VOUT, and IIN measurements are all time-aligned whereas there is a chance they may not be if read with individual PMBus commands. To read data from the MFR_AVG_BLOCK_READ command, use the SMBus Block Read protocol.

Table 37. MFR_AVG_BLOCK_READ Register Format

BYTE COUNT (ALWAYS 12)	(1 BYTE)
MFR_DIAGNOSTIC_WORD	(1 word)
AVG_IIN	(1 word)
AVG_VOUT	(1 word)
AVG_VIN	(1 word)
AVG_PIN	(1 word)
TEMPERATURE	(1 word)

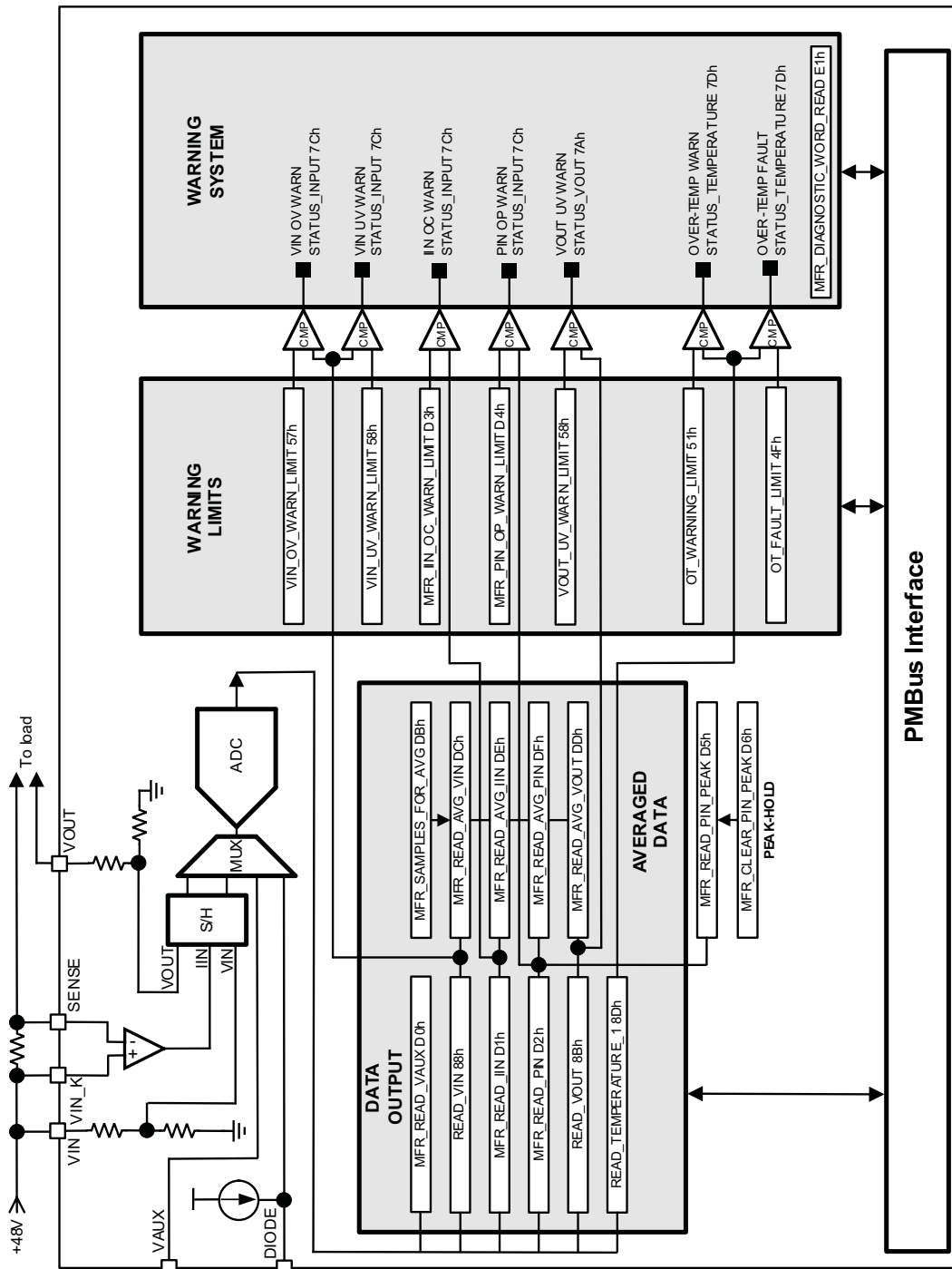

Figure 18. Command, Register and Alert Flow Diagram

Reading and Writing Telemetry Data and Warning Thresholds

All measured telemetry data and user programmed warning thresholds are communicated in 12-bit two's complement binary numbers read and written in 2-byte increments conforming to the direct format as described in section 8.3.3 of the PMBus Power System Management Protocol Specification 1.1 (Part II). The organization of the bits in the telemetry or warning word is shown in [Table 38](#), where Bit_11 is the most significant bit (MSB) and Bit_0 is the least significant bit (LSB). The decimal equivalent of all warning and telemetry words are constrained to be within the range of 0 to 4095, with the exception of temperature. The decimal equivalent value of the temperature word ranges from 0 to 65535.

Table 38. Telemetry and Warning Word Format

BYTE	B7	B6	B5	B4	B3	B2	B1	B0
1	Bit_7	Bit_6	Bit_5	Bit_4	Bit_3	Bit_2	Bit_1	Bit_0
2	0	0	0	0	Bit_11	Bit_10	Bit_9	Bit_8

Conversion from direct format to real-world dimensions of current, voltage, power, and temperature is accomplished by determining appropriate coefficients as described in section 7.2.1 of the PMBus Power System Management Protocol Specification 1.1 (Part II). According to this specification, the host system converts the values received into a reading of volts, amperes, watts, or other units using the following relationship:

$$X = \frac{1}{m} (Y \times 10^{-R} - B)$$

where

- X: the calculated *real-world* value (volts, amps, watt, etc.)
- m: the slope coefficient
- Y: a two byte two's complement integer received from device
- b: the offset, a two byte, two's complement integer
- R: the exponent, a one byte two's complement integer (3)

R is only necessary in systems where m is required to be an integer (for example, where m may be stored in a register in an integrated circuit). In those cases, R only needs to be large enough to yield the desired accuracy.

Table 39. Telemetry and Warning Conversion Coefficients

COMMANDS	CONDITION	FORMAT	NUMBER OF DATA BYTES	m	b	R	UNITS
READ_VIN MFR_READ_AVG_VIN VIN_OV_WARN_LIMIT VIN_UV_WARN_LIMIT		DIRECT	2	4612	-566	-2	V
READ_VOUT MFR_READ_AVG_VOUT VOUT_UV_WARN_LIMIT		DIRECT	2	4607	179	-2	V
MFR_READ_VAUX		DIRECT	2	13801	11	-1	V
⁽¹⁾ MFR_READ_IIN MFR_READ_AVG_IIN MFR_IIN_OC_WARN_LIMIT	CL = VDD	DIRECT	2	14985	4271	-2	A
⁽¹⁾ MFR_READ_IIN MFR_READ_AVG_IIN MFR_IIN_OC_WARN_LIMIT	CL = GND	DIRECT	2	7471	1949	-2	A
⁽¹⁾ MFR_READ_PIN MFR_READ_AVG_PIN MFR_READ_PIN_PEAK MFR_PIN_OP_WARN_LIMIT	CL = VDD	DIRECT	2	1684	22344	-3	W
⁽¹⁾ MFR_READ_PIN MFR_READ_AVG_PIN MFR_READ_PIN_PEAK MFR_PIN_OP_WARN_LIMIT	CL = GND	DIRECT	2	839	9822	-3	W
READ_TEMPERATURE_1 OT_WARN_LIMIT OT_FAULT_LIMIT		DIRECT	2	16000	0	-3	°C

(1) The coefficients relating to current/power measurements and warning thresholds shown in Table 39 are normalized to a sense resistor (RS) value of 1mΩ. In general, the current/power coefficients can be calculated using the relationships shown in Table 40.

Table 40. Current and Power Telemetry and Warning Conversion Coefficients (RS in mΩ)

COMMANDS	CONDITION	FORMAT	NUMBER OF DATA BYTES	m	b	R	UNITS
MFR_READ_IIN MFR_READ_AVG_IIN MFR_IIN_OC_WARN_LIMIT	CL = VDD	DIRECT	2	14985x RS	4271	-2	A
MFR_READ_IIN MFR_READ_AVG_IIN MFR_IIN_OC_WARN_LIMIT	CL = GND	DIRECT	2	7471 x RS	1949	-2	A
MFR_READ_PIN MFR_READ_AVG_PIN MFR_READ_PIN_PEAK MFR_PIN_OP_WARN_LIMIT	CL = VDD	DIRECT	2	1684x RS	22344	-3	W
MFR_READ_PIN MFR_READ_AVG_PIN MFR_READ_PIN_PEAK MFR_PIN_OP_WARN_LIMIT	CL = GND	DIRECT	2	839x RS	9822	-3	W

Care must be taken to adjust the exponent coefficient, R, such that the value of m remains within the range of -32768 to 32767. For example, if a 5-mΩ sense resistor (RS) is used, the correct coefficients for the READ_IIN command with CL = VDD would be m = 3736, b = 195, R = -1.

Note: The power coefficients given in Table 39 are characterized at a specific operating point of 48-V VIN. If high-power accuracy is desired at voltages other than 48 V, it is recommended to read VIN and IIN using the MFR_BLOCK_READ (DAh) command. After finding the real-world value of VIN and IIN using the coefficients, the power can simply be calculated by the multiplication of the two measurements. This will ensure the user obtains the highest accuracy power measurement. Another method to ensure accurate telemetry is to find new coefficients for your specific application. This is outlined in the proceeding section.

Determining Telemetry Coefficients Empirically with Linear Fit

The coefficients for telemetry measurements and warning thresholds presented in [Table 39](#) are adequate for the majority of applications. Current and power coefficients must be calculated per application as they are dependent on the value of the sense resistor, R_S , used. [Table 40](#) provides the equations necessary for calculating the current and power coefficients for the general case. The small signal nature of the current measurement make it and the power measurement more susceptible to PCB parasitics than other telemetry channels. This may cause slight variations in the optimum coefficients (m , b , R) for converting from Direct format digital values to real-world values (e.g., Amps and Watts). The optimum coefficients can be determined empirically for a specific application and PCB layout using two or more measurements of the telemetry channel of interest. The current coefficients can be determined using the following method:

1. While the LM5056/LM5056A is in normal operation measure the voltage across the sense resistor using Kelvin test points and a high accuracy DVM while controlling the load current. Record the integer value returned by the MFR_READ_AVG_IIN command (with the MFR_SAMPLES_FOR_AVG set to a value greater than 0) for two or more voltages across the sense resistor. For best results, the individual MFR_READ_AVG_IIN measurements should span nearly the full scale range of the current (For example, voltage across R_S of 5 mV and 20 mV).
2. Convert the measured voltages to currents by dividing them by the value of R_S . For best accuracy the value of R_S should be measured. [Table 41](#) assumes a sense resistor value of 5 m Ω .

Table 41. Measurements for Linear Fit Determination of Current Coefficients

MEASURED VOLTAGE ACROSS R_S (V)	MEASURED CURRENT (A)	READ_AVG_IIN (integer value)
0.005	1	568
0.01	2	1108
0.02	4	2185

3. Using the spreadsheet or math program of your choice determine the slope and the y-intercept of the data returned by the READ_AVG_IIN command versus the measured current. For the data shown in [Table 41](#):
 - READ_AVG_IIN value = slope x (Measured Current) + (y-intercept)
 - slope = 538.9
 - y-intercept = 29.5
4. To determine the 'm' coefficient, simply shift the decimal point of the calculated slope to arrive at an integer with a suitable number of significant digits for accuracy (typically 4) while staying with the range of -32768 to +32767. This shift in the decimal point equates to the 'R' coefficient. For the slope value shown above, the decimal point would be shifted to the right once hence $R = -1$.
5. Once the 'R' coefficient has been determined, the 'b' coefficient is found by multiplying the y-intercept by 10^{-R} . In this case the value of $b = 295$. Calculated current coefficients:
 - $m = 5389$
 - $b = 295$
 - $R = -1$

$$X = \frac{1}{m} (Y \times 10^{-R} - b)$$

where

- X: the calculated *real-world* value (volts, amps, watts, temperature)
- m: the slope coefficient, is the two byte, two's complement integer
- Y: a two byte two's complement integer received from device
- b: the offset, a two byte, two's complement integer
- R: the exponent, a one byte two's complement integer (4)

The above procedure can be repeated to determine the coefficients of any telemetry channel simply by substituting measured current for some other parameter (e.g., power, voltage, etc.). Note that the above procedure can be executed using the PMBus software GUI found in the LM5056/LM5056A online product folder

Writing Telemetry Data

There are several locations that require writing data if their optional usage is desired. Use the same coefficients previously calculated for your application, and apply them using this method as prescribed by the PMBus revision section 7.2.2 *Sending a Value*.

$$Y = (mX + b) \times 10^R$$

where

- X: the calculated *real-world* value (volts, amps, watts, temperature)
- m: the slope coefficient, is the two byte, two's complement integer
- Y: a two byte two's complement integer received from device
- b: the offset, a two byte, two's complement integer
- R: the exponent, a one byte two's complement integer

(5)

PMBus™ Address Lines (ADR0, ADR1, ADR2)

The three address lines are to be set high (connect to VDD), low (connect to GND), or open to select one of 27 addresses for communicating with the LM5056/LM5056A. [Table 42](#) depicts 7-bit addresses (eighth bit is read and write bit):

Table 42. Device Addressing

ADR2	ADR1	ADR0	DECODED ADDRESS
Z	Z	Z	40h
Z	Z	0	41h
Z	Z	1	42h
Z	0	Z	43h
Z	0	0	44h
Z	0	1	45h
Z	1	Z	46h
Z	1	0	47h
Z	1	1	10h
0	Z	Z	11h
0	Z	0	12h
0	Z	1	13h
0	0	Z	14h
0	0	0	15h
0	0	1	16h
0	1	Z	17h
0	1	0	53h
0	1	1	53h
1	Z	Z	53h
1	Z	0	53h
1	Z	1	54h
1	0	Z	56h
1	0	0	56h
1	0	1	57h
1	1	Z	58h
1	1	0	59h
1	1	1	5Ah

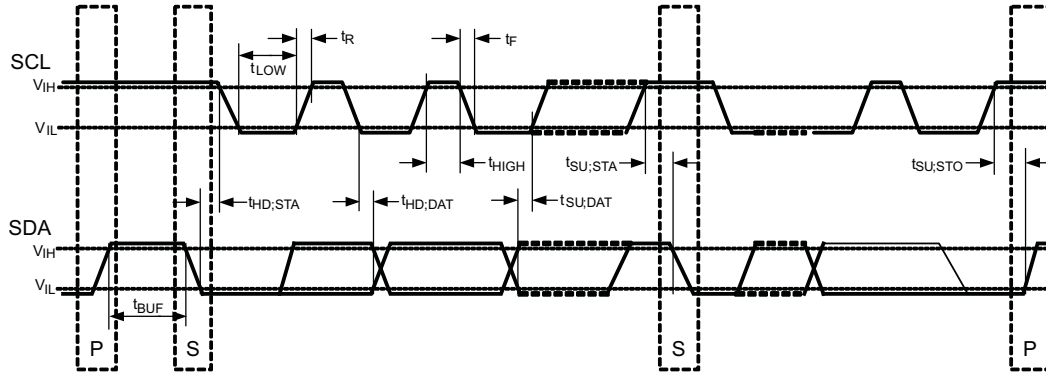

Figure 19. SMBus Timing Diagram

Table 43. SMBus Timing Definition

SYMBOL	PARAMETER	LIMITS		UNITS
		MIN	MAX	
F _{SMB}	SMBus operating frequency	10	400	kHz
T _{BUF}	Bus free time between stop and start condition	1.3		μs
T _{HD:STA}	Hold time after (repeated) start condition. After this period, the first clock is generated.	0.6		
T _{SU:STA}	Repeated start condition setup time	0.6		
T _{SU:STO}	Stop condition setup time	0.6		ns
T _{HD:DAT}	Data hold time	85		
T _{SU:DAT}	Data setup time	100		
T _{TIMEOUT}	Clock low time-out ⁽¹⁾	25	35	ms
T _{LOW}	Clock low period	1.5		μs
T _{HIGH}	Clock high period ⁽²⁾	0.6		
T _{LOW:SEXT}	Clock high period ⁽³⁾		25	ms
T _{LOW:MEXT}	Cumulative low extend time (master device) ⁽⁴⁾		10	
T _F	Clock or data fall time ⁽⁵⁾	20	300	ns
T _R	Clock or data rise time ⁽⁵⁾	20	300	

- (1) Devices participating in a transfer will timeout when any clock low exceeds the value of T_{TIMEOUT},MIN of 25 ms. Devices that have detected a timeout condition must reset the communication no later than T_{TIMEOUT},MAX of 35 ms. The maximum value must be adhered to by both a master and a slave as it incorporates the cumulative stretch limit for both a master (10 ms) and a slave (25 ms).
- (2) T_{HIGH} MAX provides a simple method for devices to detect bus idle conditions.
- (3) T_{LOW:SEXT} is the cumulative time a slave device is allowed to extend the clock cycles in one message from the initial start to the stop. If a slave exceeds this time, it is expected to release both its clock and data lines and reset itself.
- (4) T_{LOW:MEXT} is the cumulative time a master device is allowed to extend its clock cycles within each byte of a message as defined from start-to-ack, ack-to-ack, or ack-to-stop.
- (5) Rise and fall time is defined as follows:
 - (a) T_R = (V_{ILMAX} – 0.15) to (V_{IHMIN} + 0.15)
 - (b) T_F = 0.9 VDD to (V_{ILMAX} – 0.15)

SMBA Response

The $\overline{\text{SMBA}}$ effectively has two masks:

1. The Alert Mask Register at D8h, and
2. The ARA Automatic Mask.

The ARA Automatic Mask is a mask that is set in response to a successful ARA read. An ARA read operation returns the PMBus address of the lowest addressed part on the bus that has its $\overline{\text{SMBA}}$ asserted. A successful ARA read means that THIS part was the one that returned its address. When a part responds to the ARA read, it releases the $\overline{\text{SMBA}}$ signal. When the last part on the bus that has an $\overline{\text{SMBA}}$ set has successfully reported its address, the $\overline{\text{SMBA}}$ signal de-asserts.

The way that the LM5056/LM5056A releases the $\overline{\text{SMBA}}$ signal is by setting the ARA Automatic mask bit for all fault conditions present at the time of the ARA read. All status registers still show the fault condition, but it is not generated and $\overline{\text{SMBA}}$ on that fault again until the ARA Automatic mask is cleared by the host issuing a CLEAR_FAULTS command to this part. This should be done as a routine part of servicing an $\overline{\text{SMBA}}$ condition on a part, even if the ARA read is not done. Figure 20 depicts a schematic version of this flow.

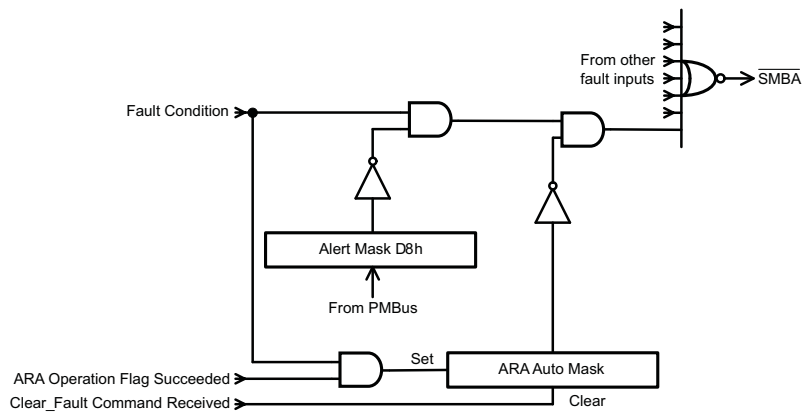

Figure 20. Typical Flow Schematic for $\overline{\text{SMBA}}$ Fault

PACKAGING INFORMATION

Orderable Device	Status (1)	Package Type	Package Drawing	Pins	Package Qty	Eco Plan (2)	Lead/Ball Finish	MSL Peak Temp (3)	Op Temp (°C)	Device Marking (4/5)	Samples
LM5056APMH/NOPB	ACTIVE	HTSSOP	PWP	28	48	Green (RoHS & no Sb/Br)	CU SN	Level-3-260C-168 HR	-40 to 125	LM5056APMH	Samples
LM5056APMHE/NOPB	ACTIVE	HTSSOP	PWP	28	250	Green (RoHS & no Sb/Br)	CU SN	Level-3-260C-168 HR	-40 to 125	LM5056APMH	Samples
LM5056APMHX/NOPB	ACTIVE	HTSSOP	PWP	28	2500	Green (RoHS & no Sb/Br)	CU SN	Level-3-260C-168 HR	-40 to 125	LM5056APMH	Samples
LM5056PMH/NOPB	ACTIVE	HTSSOP	PWP	28	48	Green (RoHS & no Sb/Br)	CU SN	Level-3-260C-168 HR	-40 to 125	LM5056PMH	Samples
LM5056PMHE/NOPB	ACTIVE	HTSSOP	PWP	28	250	Green (RoHS & no Sb/Br)	CU SN	Level-3-260C-168 HR	-40 to 125	LM5056PMH	Samples
LM5056PMHX/NOPB	ACTIVE	HTSSOP	PWP	28	2500	Green (RoHS & no Sb/Br)	CU SN	Level-3-260C-168 HR	-40 to 125	LM5056PMH	Samples

(1) The marketing status values are defined as follows:

ACTIVE: Product device recommended for new designs.

LIFEBUY: TI has announced that the device will be discontinued, and a lifetime-buy period is in effect.

NRND: Not recommended for new designs. Device is in production to support existing customers, but TI does not recommend using this part in a new design.

PREVIEW: Device has been announced but is not in production. Samples may or may not be available.

OBSOLETE: TI has discontinued the production of the device.

(2) Eco Plan - The planned eco-friendly classification: Pb-Free (RoHS), Pb-Free (RoHS Exempt), or Green (RoHS & no Sb/Br) - please check <http://www.ti.com/productcontent> for the latest availability information and additional product content details.

TBD: The Pb-Free/Green conversion plan has not been defined.

Pb-Free (RoHS): TI's terms "Lead-Free" or "Pb-Free" mean semiconductor products that are compatible with the current RoHS requirements for all 6 substances, including the requirement that lead not exceed 0.1% by weight in homogeneous materials. Where designed to be soldered at high temperatures, TI Pb-Free products are suitable for use in specified lead-free processes.

Pb-Free (RoHS Exempt): This component has a RoHS exemption for either 1) lead-based flip-chip solder bumps used between the die and package, or 2) lead-based die adhesive used between the die and leadframe. The component is otherwise considered Pb-Free (RoHS compatible) as defined above.

Green (RoHS & no Sb/Br): TI defines "Green" to mean Pb-Free (RoHS compatible), and free of Bromine (Br) and Antimony (Sb) based flame retardants (Br or Sb do not exceed 0.1% by weight in homogeneous material)

(3) MSL, Peak Temp. -- The Moisture Sensitivity Level rating according to the JEDEC industry standard classifications, and peak solder temperature.

(4) There may be additional marking, which relates to the logo, the lot trace code information, or the environmental category on the device.

(5) Multiple Device Markings will be inside parentheses. Only one Device Marking contained in parentheses and separated by a "~" will appear on a device. If a line is indented then it is a continuation of the previous line and the two combined represent the entire Device Marking for that device.

Important Information and Disclaimer: The information provided on this page represents TI's knowledge and belief as of the date that it is provided. TI bases its knowledge and belief on information provided by third parties, and makes no representation or warranty as to the accuracy of such information. Efforts are underway to better integrate information from third parties. TI has taken and continues to take reasonable steps to provide representative and accurate information but may not have conducted destructive testing or chemical analysis on incoming materials and chemicals. TI and TI suppliers consider certain information to be proprietary, and thus CAS numbers and other limited information may not be available for release.

In no event shall TI's liability arising out of such information exceed the total purchase price of the TI part(s) at issue in this document sold by TI to Customer on an annual basis.

TAPE AND REEL INFORMATION

QUADRANT ASSIGNMENTS FOR PIN 1 ORIENTATION IN TAPE

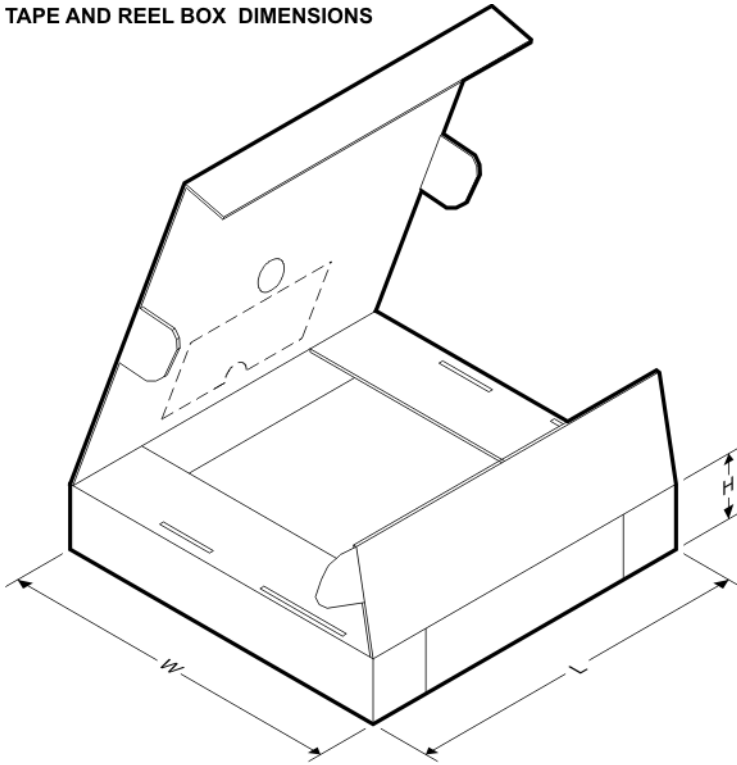

*All dimensions are nominal

Device	Package Type	Package Drawing	Pins	SPQ	Reel Diameter (mm)	Reel Width W1 (mm)	A0 (mm)	B0 (mm)	K0 (mm)	P1 (mm)	W (mm)	Pin1 Quadrant
LM5056APMHE/NOPB	HTSSOP	PWP	28	250	178.0	16.4	6.8	10.2	1.6	8.0	16.0	Q1
LM5056APMHX/NOPB	HTSSOP	PWP	28	2500	330.0	16.4	6.8	10.2	1.6	8.0	16.0	Q1
LM5056PMHE/NOPB	HTSSOP	PWP	28	250	178.0	16.4	6.8	10.2	1.6	8.0	16.0	Q1
LM5056PMHX/NOPB	HTSSOP	PWP	28	2500	330.0	16.4	6.8	10.2	1.6	8.0	16.0	Q1

TAPE AND REEL BOX DIMENSIONS

*All dimensions are nominal

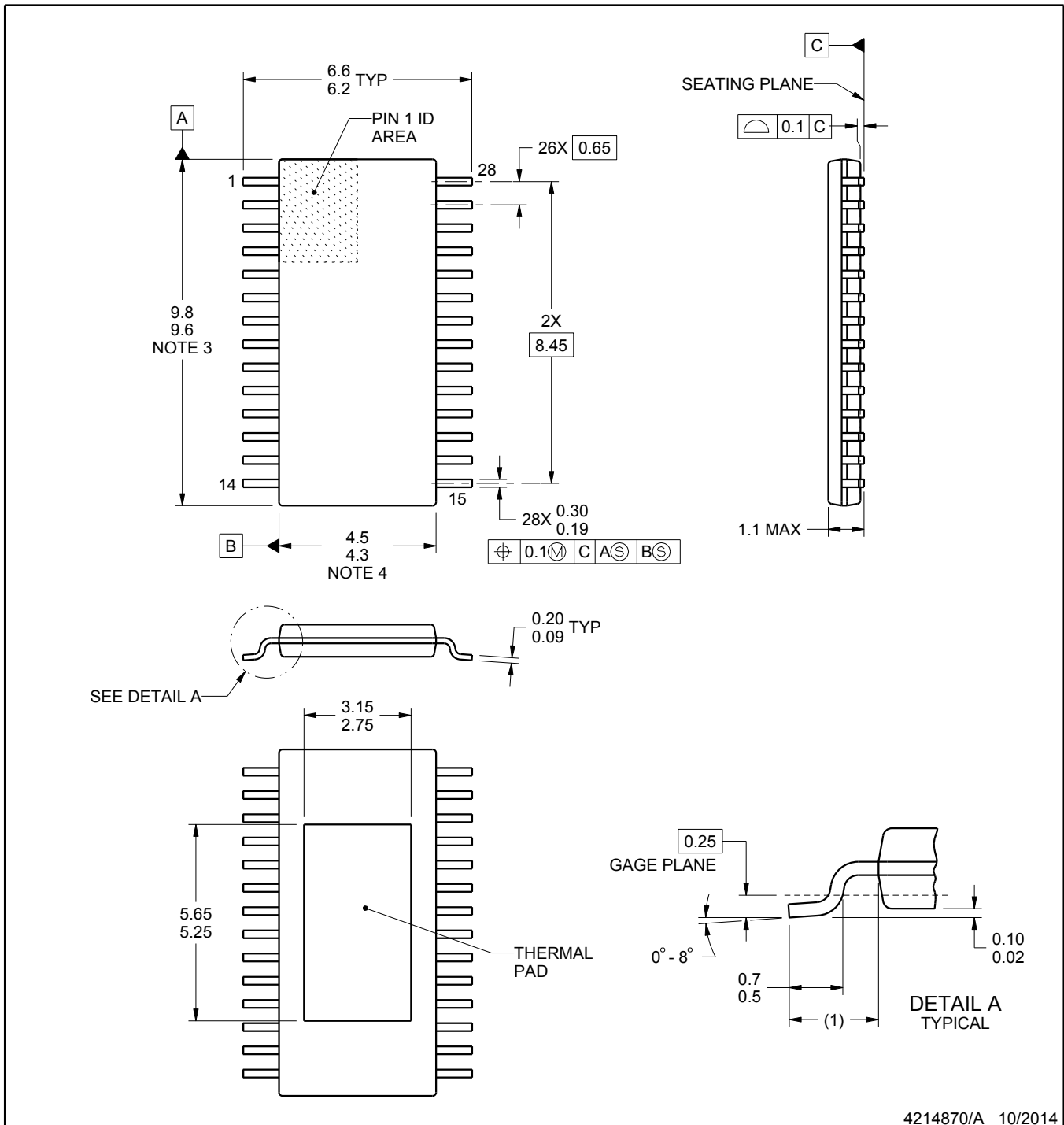
Device	Package Type	Package Drawing	Pins	SPQ	Length (mm)	Width (mm)	Height (mm)
LM5056APMHE/NOPB	HTSSOP	PWP	28	250	210.0	185.0	35.0
LM5056APMHX/NOPB	HTSSOP	PWP	28	2500	367.0	367.0	38.0
LM5056PMHE/NOPB	HTSSOP	PWP	28	250	210.0	185.0	35.0
LM5056PMHX/NOPB	HTSSOP	PWP	28	2500	367.0	367.0	38.0



4214870/A 10/2014

NOTES:

PowerPAD is a trademark of Texas Instruments.

1. All linear dimensions are in millimeters. Any dimensions in parenthesis are for reference only. Dimensioning and tolerancing per ASME Y14.5M.
2. This drawing is subject to change without notice.
3. This dimension does not include mold flash, protrusions, or gate burrs. Mold flash, protrusions, or gate burrs shall not exceed 0.15 mm, per side.
4. This dimension does not include interlead flash. Interlead flash shall not exceed 0.25 mm, per side.
5. Reference JEDEC registration MO-153, variation AET.

EXAMPLE BOARD LAYOUT

PWP0028A

PowerPAD™ - 1.1 mm max height

PLASTIC SMALL OUTLINE

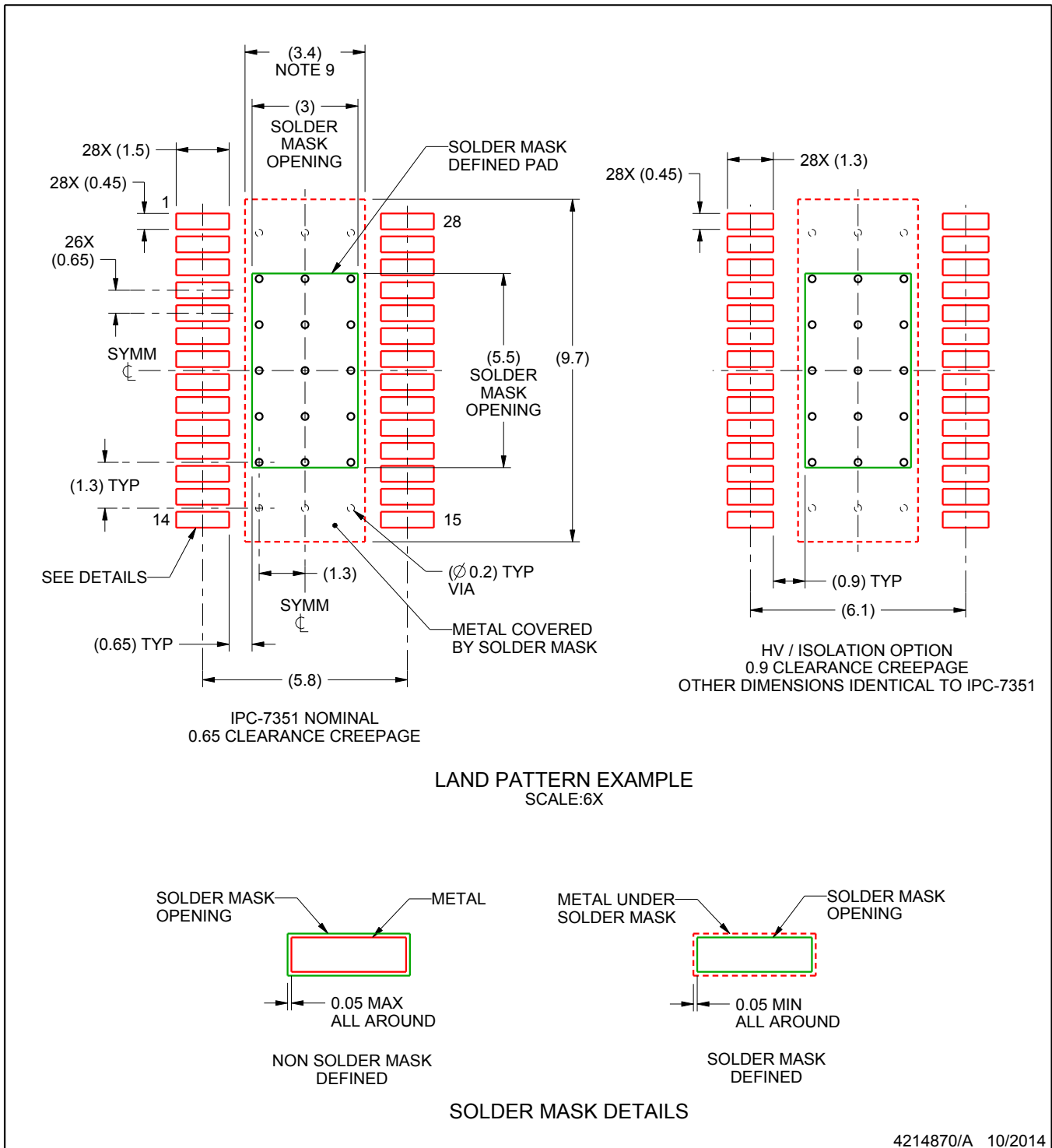

NOTES: (continued)

6. Publication IPC-7351 may have alternate designs.
7. Solder mask tolerances between and around signal pads can vary based on board fabrication site.
8. This package is designed to be soldered to a thermal pad on the board. For more information, see Texas Instruments literature numbers SLMA002 (www.ti.com/lit/slma002) and SLMA004 (www.ti.com/lit/slma004).
9. Size of metal pad may vary due to creepage requirement.

EXAMPLE STENCIL DESIGN

PWP0028A

PowerPAD™ - 1.1 mm max height

PLASTIC SMALL OUTLINE

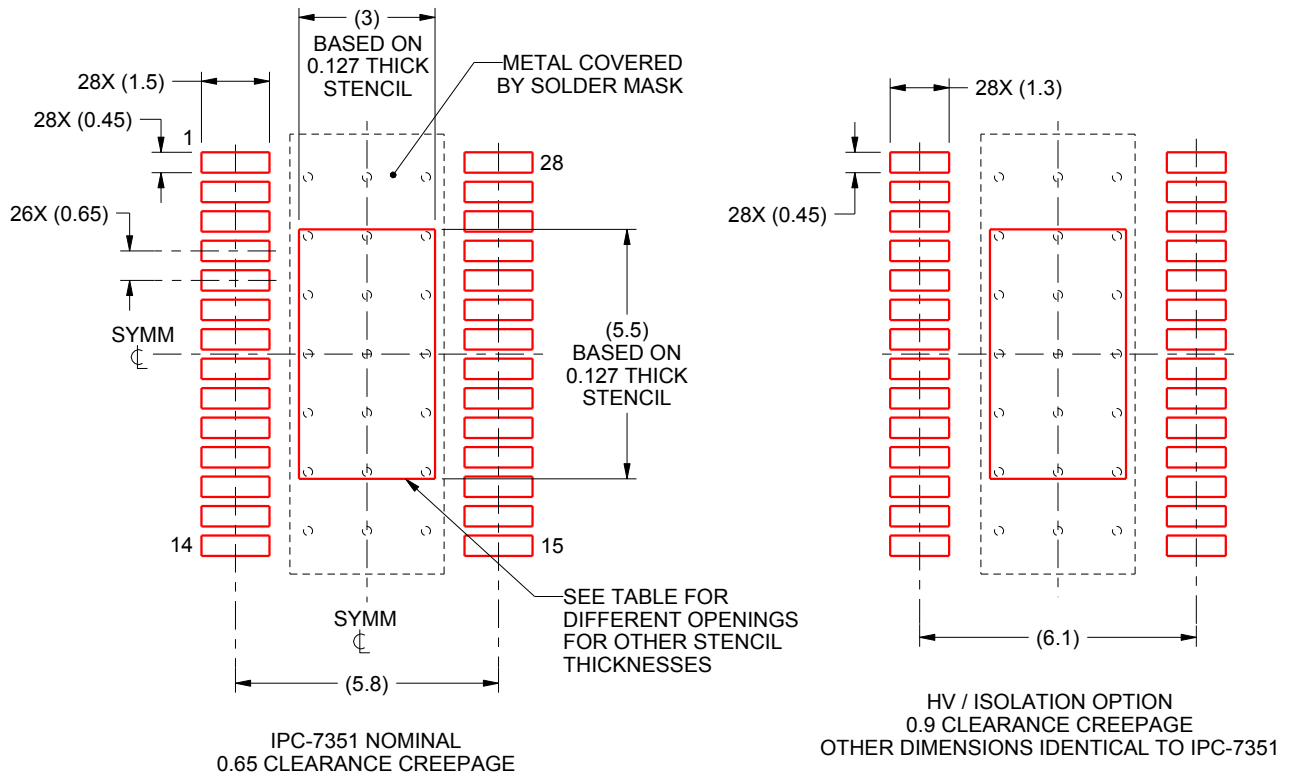

SOLDER PASTE EXAMPLE
EXPOSED PAD
100% PRINTED SOLDER COVERAGE AREA
SCALE:6X

STENCIL THICKNESS	SOLDER STENCIL OPENING
0.1	3.55 X 6.37
0.127	3.0 X 5.5 (SHOWN)
0.152	2.88 X 5.16
0.178	2.66 X 4.77

4214870/A 10/2014

NOTES: (continued)

10. Laser cutting apertures with trapezoidal walls and rounded corners may offer better paste release. IPC-7525 may have alternate design recommendations.
11. Board assembly site may have different recommendations for stencil design.

IMPORTANT NOTICE AND DISCLAIMER

TI PROVIDES TECHNICAL AND RELIABILITY DATA (INCLUDING DATASHEETS), DESIGN RESOURCES (INCLUDING REFERENCE DESIGNS), APPLICATION OR OTHER DESIGN ADVICE, WEB TOOLS, SAFETY INFORMATION, AND OTHER RESOURCES "AS IS" AND WITH ALL FAULTS, AND DISCLAIMS ALL WARRANTIES, EXPRESS AND IMPLIED, INCLUDING WITHOUT LIMITATION ANY IMPLIED WARRANTIES OF MERCHANTABILITY, FITNESS FOR A PARTICULAR PURPOSE OR NON-INFRINGEMENT OF THIRD PARTY INTELLECTUAL PROPERTY RIGHTS.

These resources are intended for skilled developers designing with TI products. You are solely responsible for (1) selecting the appropriate TI products for your application, (2) designing, validating and testing your application, and (3) ensuring your application meets applicable standards, and any other safety, security, or other requirements. These resources are subject to change without notice. TI grants you permission to use these resources only for development of an application that uses the TI products described in the resource. Other reproduction and display of these resources is prohibited. No license is granted to any other TI intellectual property right or to any third party intellectual property right. TI disclaims responsibility for, and you will fully indemnify TI and its representatives against, any claims, damages, costs, losses, and liabilities arising out of your use of these resources.

TI's products are provided subject to TI's Terms of Sale (www.ti.com/legal/termsofsale.html) or other applicable terms available either on ti.com or provided in conjunction with such TI products. TI's provision of these resources does not expand or otherwise alter TI's applicable warranties or warranty disclaimers for TI products.

Mailing Address: Texas Instruments, Post Office Box 655303, Dallas, Texas 75265
Copyright © 2019, Texas Instruments Incorporated

Looking for pricing, stock, or lifecycle information?

Click below to explore more details on WIN SOURCE:

 [View LM5056APMHX/NOPB on WIN SOURCE](#)

 [Texas Instruments](#) Information

Optimize Your Supply Chain with WIN SOURCE Solutions

-  Global Sourcing Solution
-  Obsolete Management
-  Cost Control Management
-  Shortage Management
-  Alternative Solution
-  Excess Inventory Management