



THE DATASHEET OF LM4670SDX/NOPB



LM4670 Boomer™ Audio Power Amplifier Series Filterless High Efficiency 3W Switching Audio Amplifier

Check for Samples: [LM4670](#)

FEATURES

- **No Output Filter Required for Inductive Loads**
- **Externally Configurable Gain**
- **Very Fast Turn on Time: 1.35ms (Typ)**
- **Minimum External Components**
- **"Click and Pop" Suppression Circuitry**
- **Micro-Power Shutdown Mode**
- **Short Circuit Protection**
- **Available in Space-Saving DSBGA and WSON Packages**

APPLICATIONS

- **Mobile Phones**
- **PDA's**
- **Portable Electronic Devices**

KEY SPECIFICATIONS

- **Efficiency at 3.6V, 100mW into 8Ω Speaker, 77% (Typ)**
- **Efficiency at 3.6V, 600mW into 8Ω Speaker, 88% (Typ)**
- **Efficiency at 5V, 1W into 8Ω Speaker, 87% (Typ)**
- **Quiescent Current, 3.6V Supply, 4.8mA (Typ)**
- **Total Shutdown Power Supply Current, 0.01μA (Typ)**
- **Single Supply Range, 2.4 to 5.5V**

DESCRIPTION

The LM4670 is a fully integrated single-supply high efficiency switching audio amplifier. It features an innovative modulator that eliminates the LC output filter used with typical switching amplifiers. Eliminating the output filter reduces external component count, simplifies circuit design, and reduces board area. The LM4670 processes analog inputs with a delta-sigma modulation technique that lowers output noise and THD when compared to conventional pulse width modulators.

The LM4670 is designed to meet the demands of mobile phones and other portable communication devices. Operating on a single 5V supply, it is capable of driving a 4Ω speaker load at a continuous average output of 2.3W with less than 1% THD+N. Its flexible power supply requirements allow operation from 2.4V to 5.5V.

The LM4670 has high efficiency with speaker loads compared to a typical Class AB amplifier. With a 3.6V supply driving an 8Ω speaker, the IC's efficiency for a 100mW power level is 77%, reaching 88% at 600mW output power.

The LM4670 features a low-power consumption shutdown mode. Shutdown may be enabled by driving the Shutdown pin to a logic low (GND).

The gain of the LM4670 is externally configurable which allows independent gain control from multiple sources by summing the signals.



Please be aware that an important notice concerning availability, standard warranty, and use in critical applications of Texas Instruments semiconductor products and disclaimers thereto appears at the end of this data sheet.

Boomer is a trademark of Texas Instruments.

All other trademarks are the property of their respective owners.

Typical Application

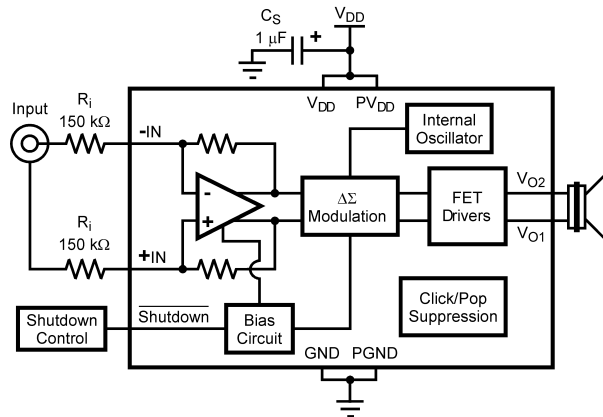
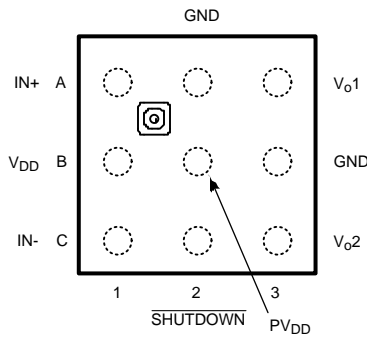
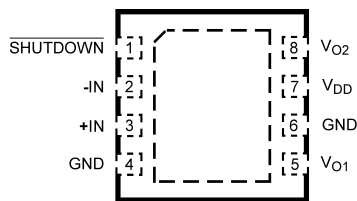

Figure 1. Typical Audio Amplifier Application Circuit

Connection Diagram



**Figure 2. 9 Bump DSBGA Package
Top View
See Package Number YZR0009**



**Figure 3. WSON Package
Top View
See Package Number NGQ0008A**



These devices have limited built-in ESD protection. The leads should be shorted together or the device placed in conductive foam during storage or handling to prevent electrostatic damage to the MOS gates.

Absolute Maximum Ratings⁽¹⁾⁽²⁾

Supply Voltage ⁽¹⁾		6.0V
Storage Temperature		-65°C to +150°C
Voltage at Any Input Pin		$V_{DD} + 0.3V \geq V \geq GND - 0.3V$
Power Dissipation ⁽³⁾		Internally Limited
ESD Susceptibility ⁽⁴⁾		2.0kV
ESD Susceptibility ⁽⁵⁾		200V
Junction Temperature (T_{JMAX})		150°C
Thermal Resistance	θ_{JA} (DSBGA)	220°C/W
	θ_{JA} (WSON)	73°C/W
Soldering Information		
See AN-1112 (SNVA009) "DSBGA Wafers Level Chip Scale Package."		

- (1) All voltages are measured with respect to the ground pin, unless otherwise specified.
- (2) *Absolute Maximum Ratings* indicate limits beyond which damage to the device may occur. *Operating Ratings* indicate conditions for which the device is functional, but do not ensure specific performance limits. *Electrical Characteristics* state DC and AC electrical specifications under particular test conditions which ensure specific performance limits. This assumes that the device is within the Operating Ratings. Specifications are not ensured for parameters where no limit is given, however, the typical value is a good indication of device performance.
- (3) The maximum power dissipation must be derated at elevated temperatures and is dictated by T_{JMAX} , θ_{JA} , and the ambient temperature T_A . The maximum allowable power dissipation is $P_{DMAX} = (T_{JMAX} - T_A) / \theta_{JA}$ or the number given in Absolute Maximum Ratings, whichever is lower. For the LM4670, $T_{JMAX} = 150^\circ\text{C}$. The typical θ_{JA} is 220°C/W for the DSBGA package and 64°C/W for the WSON package.
- (4) Human body model, 100pF discharged through a 1.5kΩ resistor.
- (5) Machine Model, 220pF – 240pF discharged through all pins.

Operating Ratings^{(1) (2)}

Temperature Range	$T_{MIN} \leq T_A \leq T_{MAX}$	$-40^\circ\text{C} \leq T_A \leq 85^\circ\text{C}$
	Supply Voltage ⁽³⁾	$2.4V \leq V_{DD} \leq 5.5V$

- (1) All voltages are measured with respect to the ground pin, unless otherwise specified.
- (2) *Absolute Maximum Ratings* indicate limits beyond which damage to the device may occur. *Operating Ratings* indicate conditions for which the device is functional, but do not ensure specific performance limits. *Electrical Characteristics* state DC and AC electrical specifications under particular test conditions which ensure specific performance limits. This assumes that the device is within the Operating Ratings. Specifications are not ensured for parameters where no limit is given, however, the typical value is a good indication of device performance.
- (3) The maximum operating voltage for the LM4670 in the SDA (WSON) package when driving 4Ω loads to greater than 10% THD+N is 5.0V.

Electrical Characteristics⁽¹⁾⁽²⁾

The following specifications apply for $A_V = 2V/V$ ($R_I = 150k\Omega$), $R_L = 15\mu H + 8\Omega + 15\mu H$ unless otherwise specified. Limits apply for $T_A = 25^\circ C$.

Symbol	Parameter	Conditions	LM4670		Units (Limits)
			Typical ⁽³⁾	Limit ⁽⁴⁾⁽⁵⁾	
$ V_{OS} $	Differential Output Offset Voltage	$V_I = 0V$, $A_V = 2V/V$, $V_{DD} = 2.4V$ to $5.0V$		25	mV (max)
$PSRR_{GSM}$	GSM Power Supply Rejection Ratio	$V_{DD} = 2.4V$ to $5.0V$, Input Referred	64		dB
$CMRR_{GSM}$	GSM Common Mode Rejection Ratio	$V_{DD} = 2.4V$ to $5.0V$ $V_{IC} = V_{DD}/2$ to $0.5V$, $V_{IC} = V_{DD}/2$ to $V_{DD} - 0.8V$, Input Referred	80		dB
$ I_{IH} $	Logic High Input Current	$V_{DD} = 5.0V$, $V_I = 5.8V$	20	100	μA (max)
$ I_{IL} $	Logic Low Input Current	$V_{DD} = 5.0V$, $V_I = -0.3V$	1	5	μA (max)
I_{DD}	Quiescent Power Supply Current	$V_{IN} = 0V$, No Load, $V_{DD} = 5.0V$	7.0	10	mA (max)
		$V_{IN} = 0V$, No Load, $V_{DD} = 3.6V$	4.8		mA
		$V_{IN} = 0V$, No Load, $V_{DD} = 2.4V$	3.8	5	mA (max)
I_{SD}	Shutdown Current ⁽⁶⁾	$V_{SHUTDOWN} = 0V$ $V_{DD} = 2.4V$ to $5.0V$	0.01	1	μA (max)
V_{SDIH}	Shutdown voltage input high		1.0	1.4	V (min)
V_{SDIL}	Shutdown voltage input low		0.8	0.4	V (max)
R_{OSD}	Output Impedance	$V_{SHUTDOWN} = 0.4V$	>100		k Ω
A_V	Gain		$300k\Omega/R_I$	$270k\Omega/R_I$ $330k\Omega/R_I$	V/V (min) V/V (max)
R_{SD}	Resistance from Shutdown Pin to GND		300		k Ω
P_O	Output Power ⁽⁷⁾⁽⁸⁾	$R_L = 15\mu H + 4\Omega + 15\mu H$, THD = 10% (max) $f = 1kHz$, 22kHz BW $V_{DD} = 5V$ $V_{DD} = 3.6V$ $V_{DD} = 2.5V$	3.0 1.5 675		W W mW
		$R_L = 15\mu H + 4\Omega + 15\mu H$, THD+N = 1% (max) $f = 1kHz$, 22kHz BW $V_{DD} = 5V$, $V_{DD} = 3.6V$, $V_{DD} = 2.5V$,	2.3 1.2 550		W W mW

- (1) All voltages are measured with respect to the ground pin, unless otherwise specified.
- (2) *Absolute Maximum Ratings* indicate limits beyond which damage to the device may occur. *Operating Ratings* indicate conditions for which the device is functional, but do not ensure specific performance limits. *Electrical Characteristics* state DC and AC electrical specifications under particular test conditions which ensure specific performance limits. This assumes that the device is within the Operating Ratings. Specifications are not ensured for parameters where no limit is given, however, the typical value is a good indication of device performance.
- (3) Typical specifications are specified at $25^\circ C$ and represent the parametric norm.
- (4) Tested limits are specified to Texas Instruments' AOQL (Average Outgoing Quality Level).
- (5) Datasheet min/max specification limits are ensured by design, test, or statistical analysis.
- (6) Shutdown current is measured in a normal room environment. Exposure to direct sunlight will increase I_{SD} by a maximum of $2\mu A$. The Shutdown pin should be driven as close as possible to GND for minimal shutdown current. See [Application Information](#) under [SHUTDOWN FUNCTION](#) for more information.
- (7) Typical output power numbers are for the LM4670 in the ITL (DSBGA) package. In the WSON (SDA) package, the output power will be lower due to higher resistance seen from the IC output pad to PCB trace. The difference increases with lower impedance loads.
- (8) The maximum operating voltage for the LM4670 in the SDA (WSON) package when driving 4Ω loads to greater than 10% THD+N is $5.0V$.

Electrical Characteristics⁽¹⁾⁽²⁾ (continued)

The following specifications apply for $A_V = 2V/V$ ($R_I = 150k\Omega$), $R_L = 15\mu H + 8\Omega + 15\mu H$ unless otherwise specified. Limits apply for $T_A = 25^\circ C$.

Symbol	Parameter	Conditions	LM4670		Units (Limits)
			Typical ⁽³⁾	Limit ⁽⁴⁾⁽⁵⁾	
P _O	Output Power ⁽⁷⁾	R _L = 15μH + 8Ω + 15μH, THD = 10% (max) f = 1kHz, 22kHz BW V _{DD} = 5V V _{DD} = 3.6V V _{DD} = 2.5V	1.65 850 400		W mW mW
		R _L = 15μH + 8Ω + 15μH, THD+N = 1% (max) f = 1kHz, 22kHz BW V _{DD} = 5V, V _{DD} = 3.6V, V _{DD} = 2.5V,	1.35 680 325	600	W mW (min) mW
THD+N	Total Harmonic Distortion + Noise	V _{DD} = 5V, P _O = 1W _{RMS} , f = 1kHz	0.35		%
		V _{DD} = 3.6V, P _O = 0.5W _{RMS} , f = 1kHz	0.30		%
		V _{DD} = 3.6V, P _O = 0.5W _{RMS} , f = 5kHz	0.30		%
		V _{DD} = 3.6V, P _O = 0.5W _{RMS} , f = 10kHz	0.30		%
PSRR	Power Supply Rejection Ratio	V _{DD} = 3.6V, V _{Ripple} = 200mV _{PP} Sine, f _{Ripple} = 217Hz Inputs to AC GND, C _I = 0.1μ, Input Referred	68		dB
		V _{DD} = 3.6V, V _{Ripple} = 200mV _{PP} Sine, f _{Ripple} = 1kHz Inputs to AC GND, C _I = 0.1μF Input Referred	65		dB
		V _{DD} = 3.6V, V _{Ripple} = 200mV _{PP} Sine, f _{Ripple} = 217Hz f _{IN} = 1kHz, P _O = 10mW _{RMS} Input Referred	62		dB
SNR	Signal to Noise Ratio	V _{DD} = 5V, P _O = 1W _{RMS}	93		dB
ε _{OUT}	Output Noise	V _{DD} = 3.6V, f = 20Hz – 20kHz Inputs to AC GND, C _I = 0.1μF No Weighting, Input Referred	85		μV _{RMS}
		V _{DD} = 3.6V, Inputs to AC GND C _I = 0.1μF, A Weighted Input Referred	65		μV _{RMS}
CMRR	Common Mode Rejection Ratio	V _{DD} = 3.6V, V _{Ripple} = 1V _{PP} Sine f _{Ripple} = 217Hz, Input Referred	80		dB
T _{WU}	Wake-up Time	V _{DD} = 3.6V	1.35		ms
T _{SD}	Shutdown Time	V _{DD} = 3.6V	0.01		ms

External Components Description

See [Figure 1](#)

Components		Functional Description
1.	C _S	Supply bypass capacitor which provides power supply filtering. Refer to POWER SUPPLY BYPASSING for information concerning proper placement and selection of the supply bypass capacitor.
2.	R _I	Gain setting resistor. Differential gain is set by the equation $A_V = 2 * 150k\Omega / R_I(V/V)$.

Typical Performance Characteristics⁽¹⁾

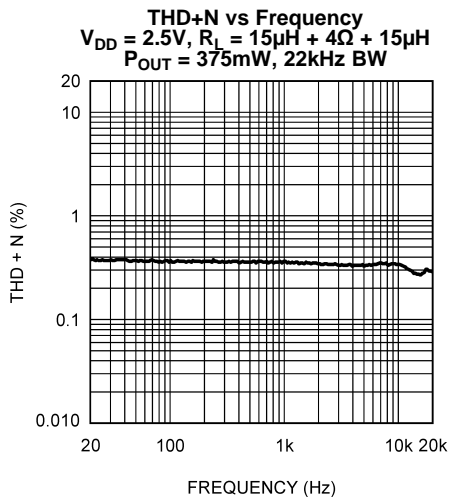

Figure 4.

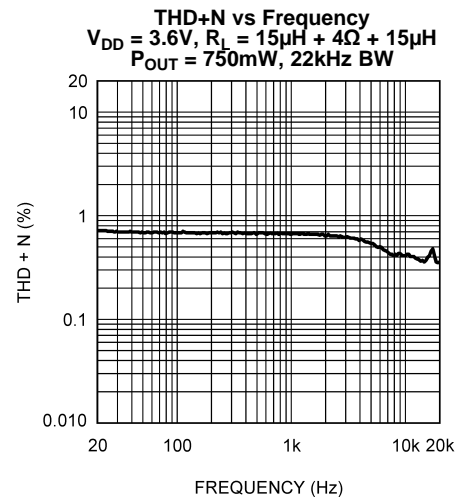

Figure 5.

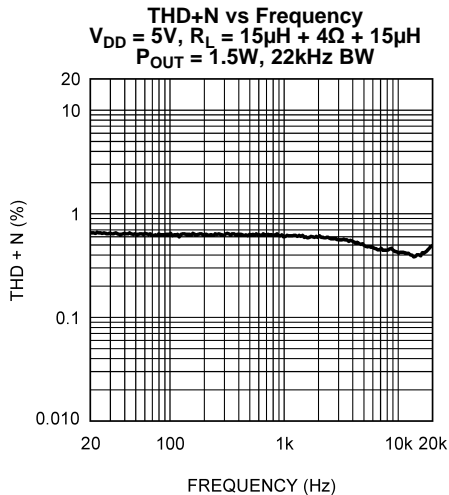

Figure 6.

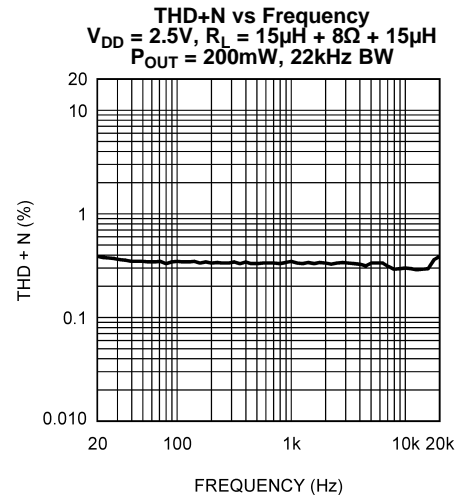

Figure 7.

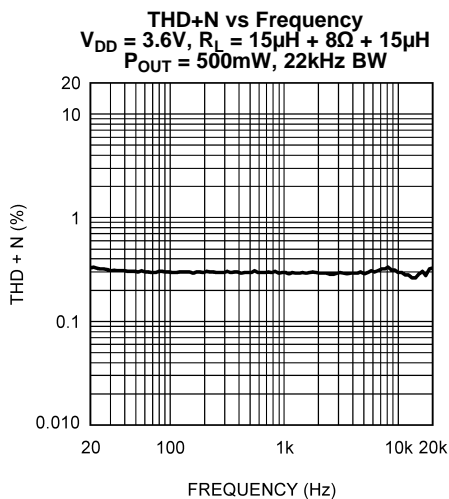

Figure 8.

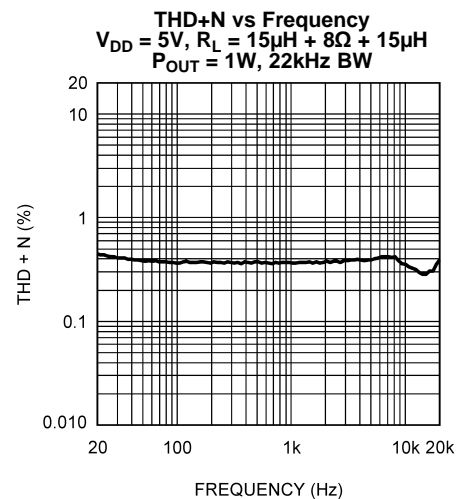

Figure 9.

(1) The performance graphs were taken using the Audio Precision AUX-0025 Switching Amplifier Measurement Filter in series with the LC filter on the board.

Typical Performance Characteristics⁽¹⁾ (continued)

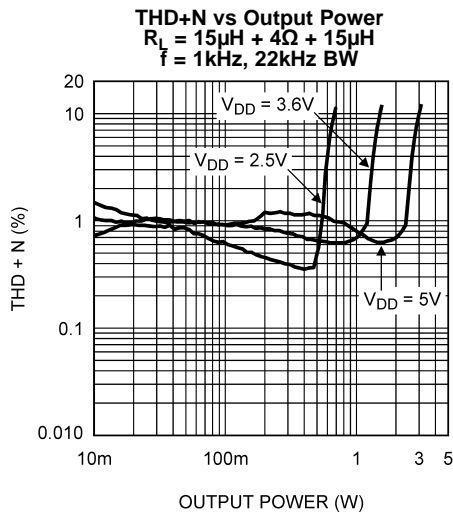

Figure 10.

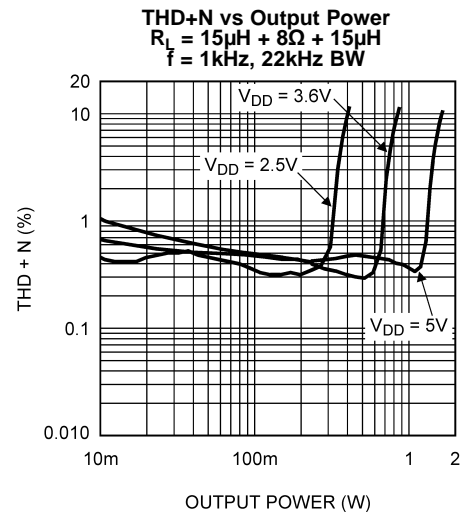

Figure 11.

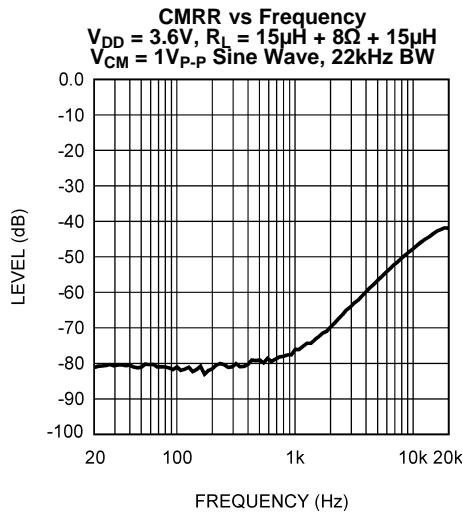

Figure 12.

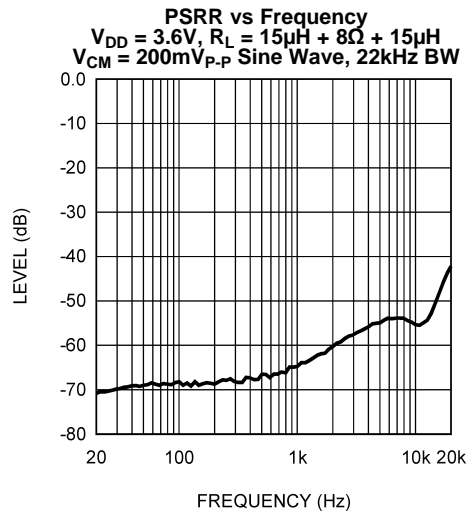

Figure 13.

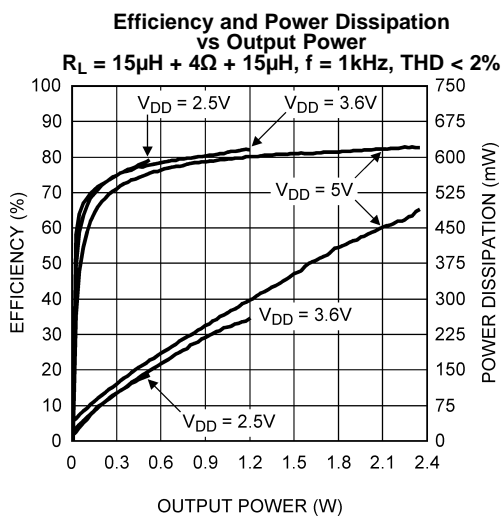

Figure 14.

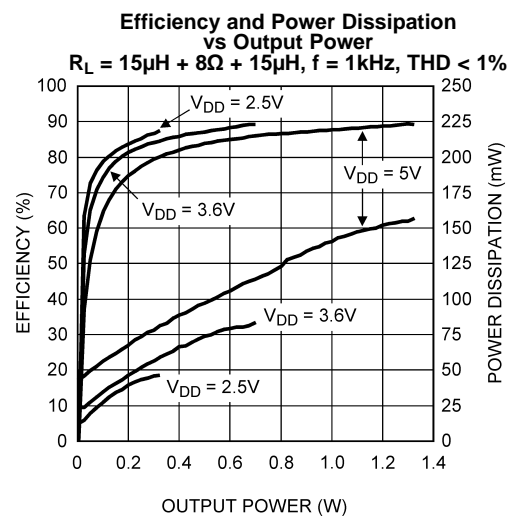

Figure 15.

Typical Performance Characteristics⁽¹⁾ (continued)

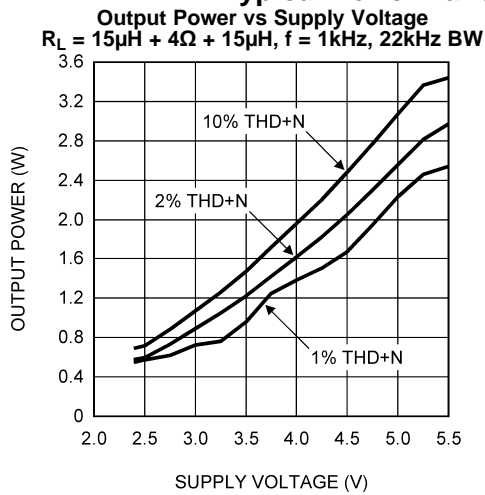

Figure 16.

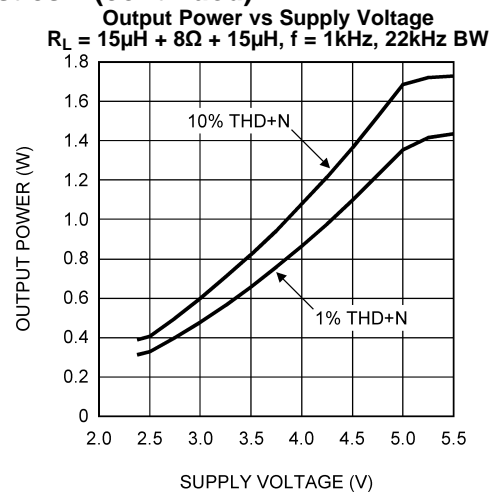

Figure 17.

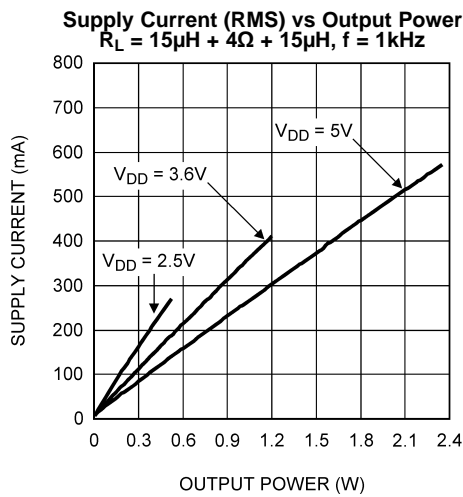

Figure 18.

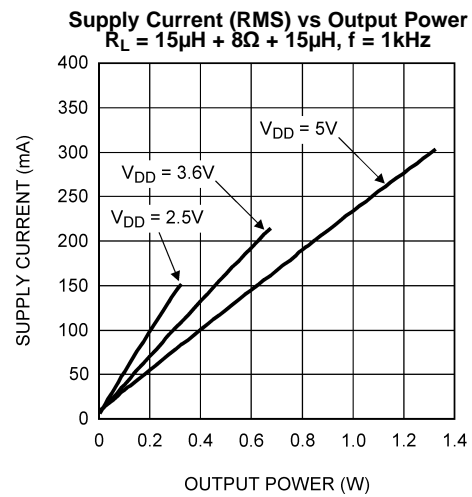

Figure 19.

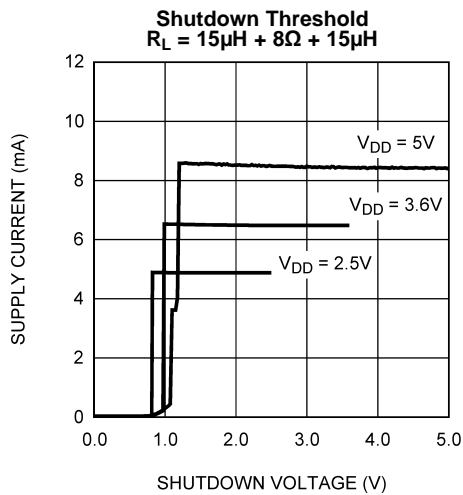

Figure 20.

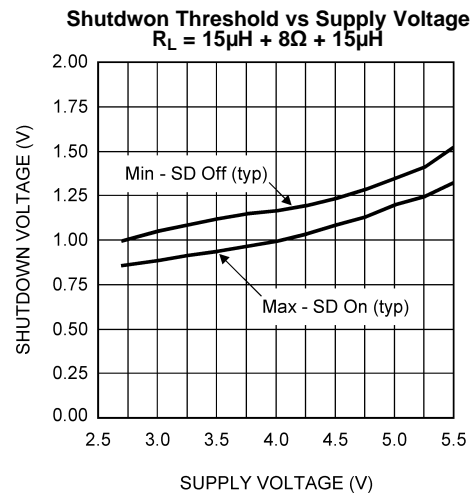

Figure 21.

Typical Performance Characteristics⁽¹⁾ (continued)

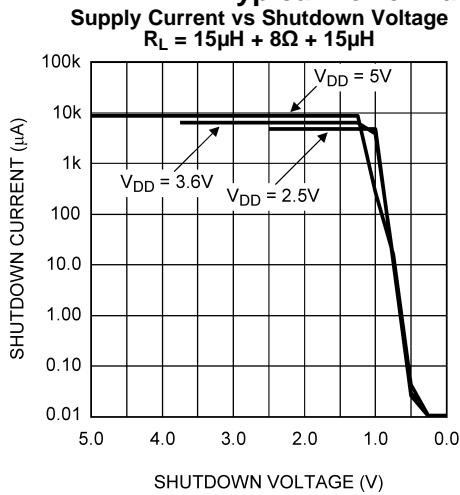

Figure 22.

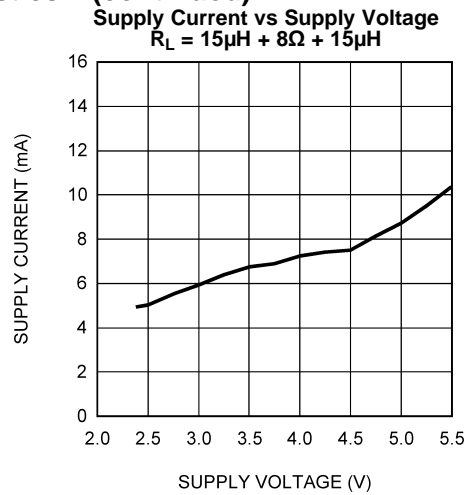

Figure 23.

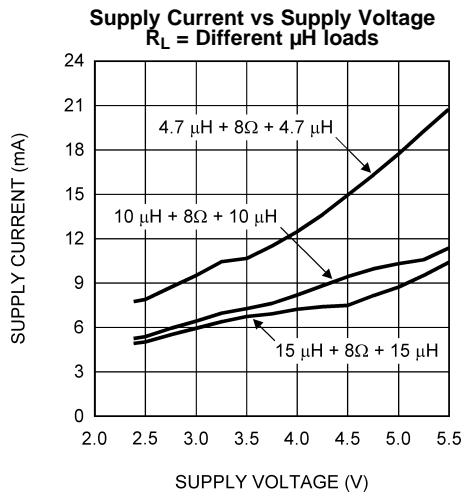

Figure 24.

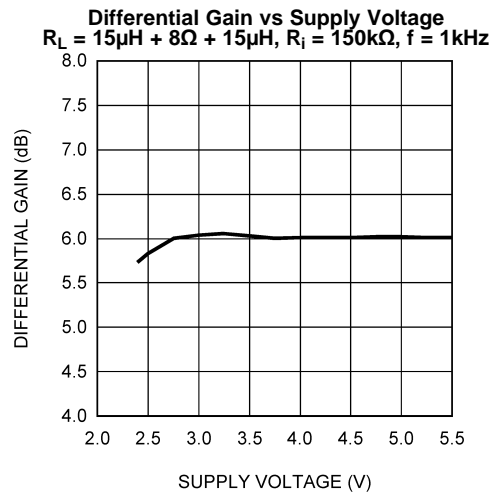

Figure 25.

APPLICATION INFORMATION

GENERAL AMPLIFIER FUNCTION

The output signals generated by the LM4670 consist of two, BTL connected, output signals that pulse momentarily from near ground potential to V_{DD} . The two outputs can pulse independently with the exception that they both may never pulse simultaneously as this would result in zero volts across the BTL load. The minimum width of each pulse is approximately 350ns. However, pulses on the same output can occur sequentially, in which case they are concatenated and appear as a single wider pulse to achieve an effective 100% duty cycle. This results in maximum audio output power for a given supply voltage and load impedance. The LM4670 can achieve much higher efficiencies than class AB amplifiers while maintaining acceptable THD performance.

The short (350ns) drive pulses emitted at the LM4670 outputs means that good efficiency can be obtained with minimal load inductance. The typical transducer load on an audio amplifier is quite reactive (inductive). For this reason, the load can act as its own filter, so to speak. This "filter-less" switching amplifier/transducer load combination is much more attractive economically due to savings in board space and external component cost by eliminating the need for a filter.

POWER DISSIPATION AND EFFICIENCY

In general terms, efficiency is considered to be the ratio of useful work output divided by the total energy required to produce it with the difference being the power dissipated, typically, in the IC. The key here is "useful" work. For audio systems, the energy delivered in the audible bands is considered useful including the distortion products of the input signal. Sub-sonic (DC) and super-sonic components (>22kHz) are not useful. The difference between the power flowing from the power supply and the audio band power being transduced is dissipated in the LM4670 and in the transducer load. The amount of power dissipation in the LM4670 is very low. This is because the ON resistance of the switches used to form the output waveforms is typically less than 0.25 Ω . This leaves only the transducer load as a potential "sink" for the small excess of input power over audio band output power. The LM4670 dissipates only a fraction of the excess power requiring no additional PCB area or copper plane to act as a heat sink.

DIFFERENTIAL AMPLIFIER EXPLANATION

As logic supply voltages continue to shrink, designers are increasingly turning to differential analog signal handling to preserve signal to noise ratios with restricted voltage swing. The LM4670 is a fully differential amplifier that features differential input and output stages. A differential amplifier amplifies the difference between the two input signals. Traditional audio power amplifiers have typically offered only single-ended inputs resulting in a 6dB reduction in signal to noise ratio relative to differential inputs. The LM4670 also offers the possibility of DC input coupling which eliminates the two external AC coupling, DC blocking capacitors. The LM4670 can be used, however, as a single ended input amplifier while still retaining its fully differential benefits. In fact, completely unrelated signals may be placed on the input pins. The LM4670 simply amplifies the difference between the signals. A major benefit of a differential amplifier is the improved common mode rejection ratio (CMRR) over single input amplifiers. The common-mode rejection characteristic of the differential amplifier reduces sensitivity to ground offset related noise injection, especially important in high noise applications.

PCB LAYOUT CONSIDERATIONS

As output power increases, interconnect resistance (PCB traces and wires) between the amplifier, load and power supply create a voltage drop. The voltage loss on the traces between the LM4670 and the load results in lower output power and decreased efficiency. Higher trace resistance between the supply and the LM4670 has the same effect as a poorly regulated supply, increase ripple on the supply line also reducing the peak output power. The effects of residual trace resistance increases as output current increases due to higher output power, decreased load impedance or both. To maintain the highest output voltage swing and corresponding peak output power, the PCB traces that connect the output pins to the load and the supply pins to the power supply should be as wide as possible to minimize trace resistance.

The use of power and ground planes will give the best THD+N performance. While reducing trace resistance, the use of power planes also creates parasite capacitors that help to filter the power supply line.

The rising and falling edges are necessarily short in relation to the minimum pulse width (350ns), having approximately 16ns rise and fall times, typical, depending on parasitic output capacitance. The inductive nature of the transducer load can also result in overshoot on one or both edges, clamped by the parasitic diodes to GND and V_{DD} in each case. From an EMI standpoint, this is an aggressive waveform that can radiate or conduct to other components in the system and cause interference. It is essential to keep the power and output traces short and well shielded if possible. Use of ground planes, beads, and micro-strip layout techniques are all useful in preventing unwanted interference.

As the distance from the LM4670 and the speaker increase, the amount of EMI radiation will increase since the output wires or traces acting as antenna become more efficient with length. What is acceptable EMI is highly application specific. Ferrite chip inductors placed close to the LM4670 may be needed to reduce EMI radiation. The value of the ferrite chip is very application specific.

POWER SUPPLY BYPASSING

As with any power amplifier, proper supply bypassing is critical for low noise performance and high power supply rejection ratio (PSRR). The capacitor (C_S) location should be as close as possible to the LM4670. Typical applications employ a voltage regulator with a 10 μ F and a 0.1 μ F bypass capacitors that increase supply stability. These capacitors do not eliminate the need for bypassing on the supply pin of the LM4670. A 1 μ F tantalum capacitor is recommended.

SHUTDOWN FUNCTION

In order to reduce power consumption while not in use, the LM4670 contains shutdown circuitry that reduces current draw to less than 0.01 μ A. The trigger point for shutdown is shown as a typical value in [Electrical Characteristics](#) and in the Shutdown Hysteresis Voltage graphs found in [Typical Performance Characteristics](#). It is best to switch between ground and supply for minimum current usage while in the shutdown state. While the LM4670 may be disabled with shutdown voltages in between ground and supply, the idle current will be greater than the typical 0.01 μ A value. Increased THD may also be observed with voltages less than V_{DD} on the Shutdown pin when in PLAY mode.

The LM4670 has an internal resistor connected between GND and Shutdown pins. The purpose of this resistor is to eliminate any unwanted state changes when the Shutdown pin is floating. The LM4670 will enter the shutdown state when the Shutdown pin is left floating or if not floating, when the shutdown voltage has crossed the threshold. To minimize the supply current while in the shutdown state, the Shutdown pin should be driven to GND or left floating. If the Shutdown pin is not driven to GND, the amount of additional resistor current due to the internal shutdown resistor can be found by [Equation 1](#).

$$(V_{SD} - GND) / 300k\Omega \quad (1)$$

With only a 0.5V difference, an additional 1.7 μ A of current will be drawn while in the shutdown state.

PROPER SELECTION OF EXTERNAL COMPONENTS

The gain of the LM4670 is set by the external resistors, R_i in [Figure 1](#), The Gain is given by [Equation 2](#). Best THD+N performance is achieved with a gain of 2V/V (6dB).

$$A_v = 2 * 150 k\Omega / R_i (V/V) \quad (2)$$

It is recommended that resistors with 1% tolerance or better be used to set the gain of the LM4670. The R_i resistors should be placed close to the input pins of the LM4670. Keeping the input traces close to each other and of the same length in a high noise environment will aid in noise rejection due to the good CMRR of the LM4670. Noise coupled onto input traces which are physically close to each other will be common mode and easily rejected by the LM4670.

Input capacitors may be needed for some applications or when the source is single-ended (see [Figure 27](#) and [Figure 29](#)). Input capacitors are needed to block any DC voltage at the source so that the DC voltage seen between the input terminals of the LM4670 is 0V. Input capacitors create a high-pass filter with the input resistors, R_i . The -3dB point of the high-pass filter is found using [Equation 3](#).

$$f_c = 1 / (2\pi R_i C_i) (Hz) \quad (3)$$

The input capacitors may also be used to remove low audio frequencies. Small speakers cannot reproduce low bass frequencies so filtering may be desired. When the LM4670 is using a single-ended source, power supply noise on the ground is seen as an input signal by the +IN input pin that is capacitor coupled to ground (see [Figure 29](#) to [Figure 31](#)). Setting the high-pass filter point above the power supply noise frequencies, 217Hz in a GSM phone, for example, will filter out this noise so it is not amplified and heard on the output. Capacitors with a tolerance of 10% or better are recommended for impedance matching.

DIFFERENTIAL CIRCUIT CONFIGURATIONS

The LM4670 can be used in many different circuit configurations. The simplest and best performing is the DC coupled, differential input configuration shown in [Figure 26](#). [Equation 2](#) above is used to determine the value of the R_i resistors for a desired gain.

Input capacitors can be used in a differential configuration as shown in [Figure 27](#). [Equation 3](#) above is used to determine the value of the C_i capacitors for a desired frequency response due to the high-pass filter created by C_i and R_i . [Equation 2](#) above is used to determine the value of the R_i resistors for a desired gain

The LM4670 can be used to amplify more than one audio source. [Figure 28](#) shows a dual differential input configuration. The gain for each input can be independently set for maximum design flexibility using the R_i resistors for each input and [Equation 2](#). Input capacitors can be used with one or more sources as well to have different frequency responses depending on the source or if a DC voltage needs to be blocked from a source.

SINGLE-ENDED CIRCUIT CONFIGURATIONS

The LM4670 can also be used with single-ended sources but input capacitors will be needed to block any DC at the input terminals. [Figure 29](#) shows the typical single-ended application configuration. The equations for Gain, [Equation 2](#), and frequency response, [Equation 3](#), hold for the single-ended configuration as shown in [Figure 29](#).

When using more than one single-ended source as shown in [Figure 30](#), the impedance seen from each input terminal should be equal. To find the correct values for C_{i3} and R_{i3} connected to the +IN input pin the equivalent impedance of all the single-ended sources are calculated. The single-ended sources are in parallel to each other. The equivalent capacitor and resistor, C_{i3} and R_{i3} , are found by calculating the parallel combination of all C_i values and then all R_i values. [Equation 4](#) and [Equation 5](#) below are for any number of single-ended sources.

$$C_{i3} = C_{i1} + C_{i2} + C_{in} \dots \text{ (F)} \quad (4)$$

$$R_{i3} = 1 / (1/R_{i1} + 1/R_{i2} + 1/R_{in} \dots) \text{ (}\Omega\text{)} \quad (5)$$

The LM4670 may also use a combination of single-ended and differential sources. A typical application with one single-ended source and one differential source is shown in [Figure 31](#). Using the principle of superposition, the external component values can be determined with the above equations corresponding to the configuration.

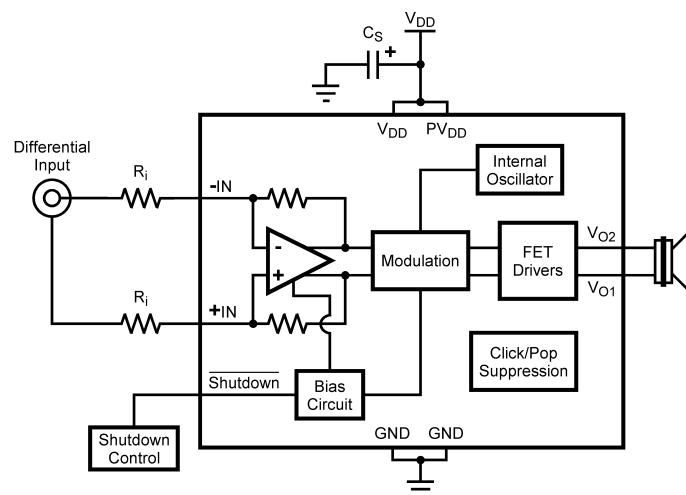

Figure 26. Differential input configuration

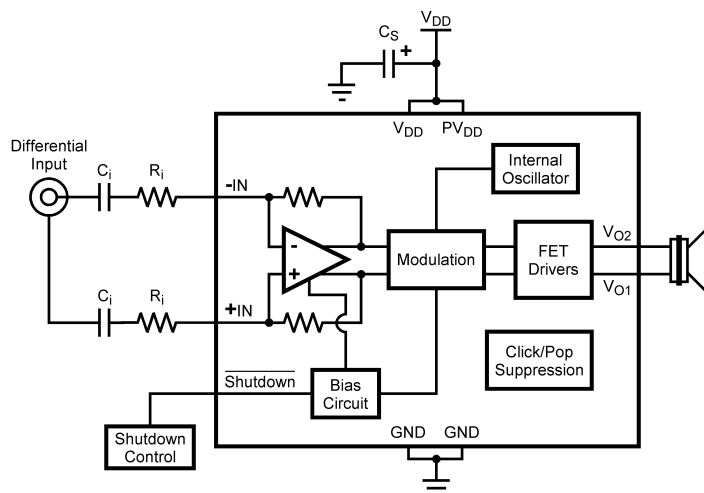

Figure 27. Differential input configuration with input capacitors

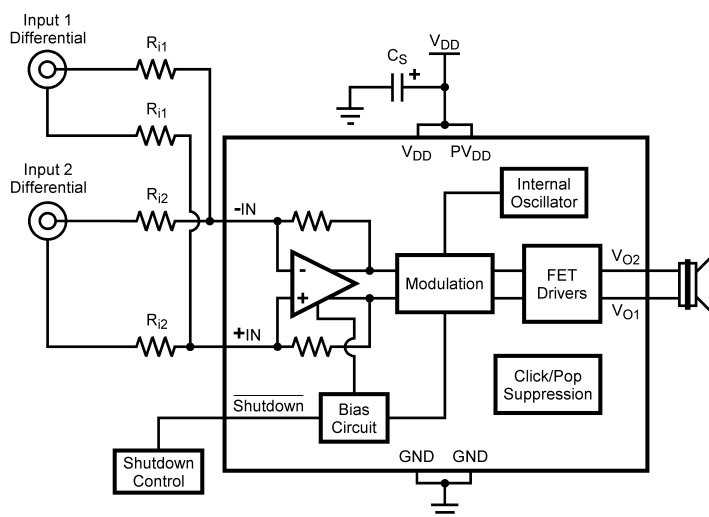

Figure 28. Dual differential input configuration

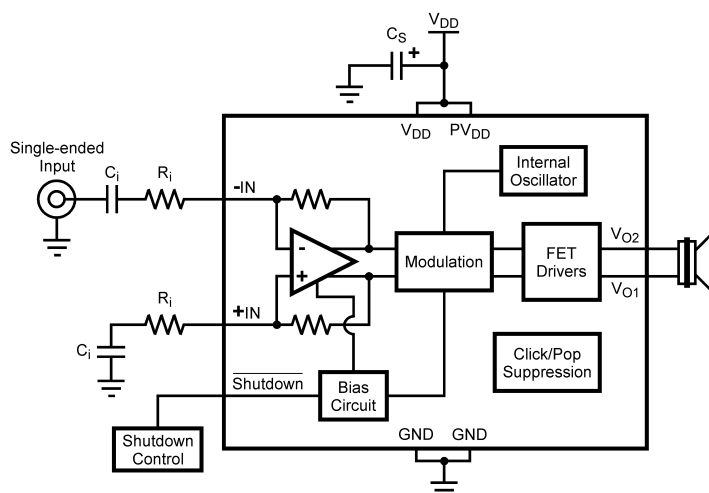

Figure 29. Single-ended input configuration

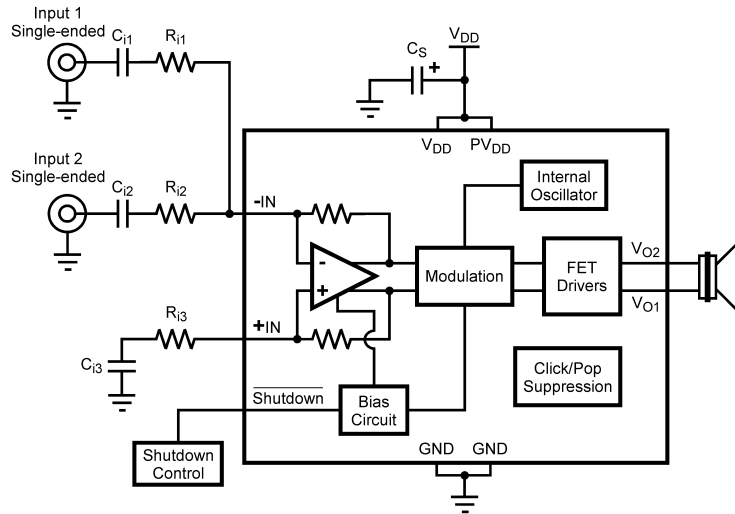

Figure 30. Dual single-ended input configuration

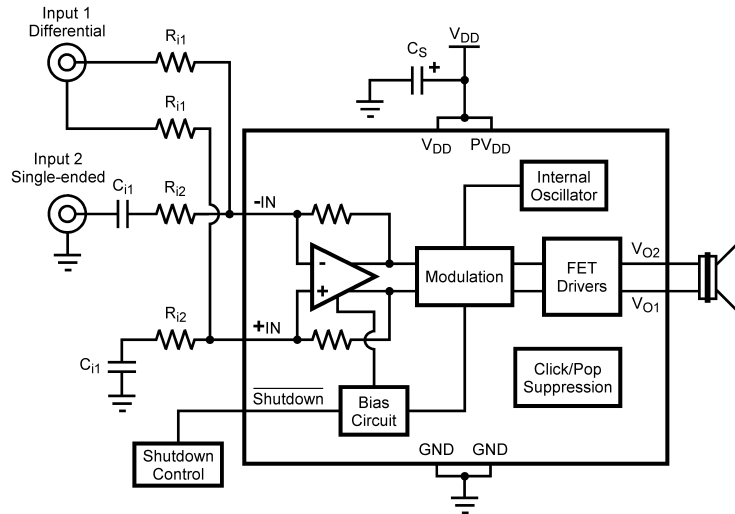

Figure 31. Dual input with a single-ended input and a differential input

REFERENCE DESIGN BOARD SCHEMATIC

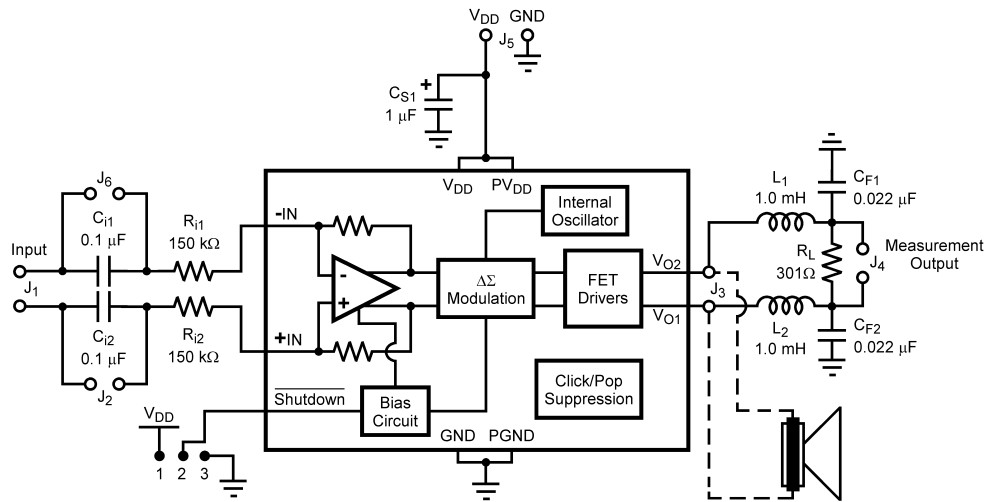

Figure 32. Reference Design Board Schematic

In addition to the minimal parts required for the application circuit, a measurement filter is provided on the evaluation circuit board so that conventional audio measurements can be conveniently made without additional equipment. This is a balanced input, grounded differential output low pass filter with a 3dB frequency of approximately 35kHz and an on board termination resistor of 300Ω (see Figure 32). Note that the capacitive load elements are returned to ground. This is not optimal for common mode rejection purposes, but due to the independent pulse format at each output there is a significant amount of high frequency common mode component on the outputs. The grounded capacitive filter elements attenuate this component at the board to reduce the high frequency CMRR requirement placed on the analysis instruments.

Even with the grounded filter the audio signal is still differential, necessitating a differential input on any analysis instrument connected to it. Most lab instruments that feature BNC connectors on their inputs are **NOT** differential responding because the ring of the BNC is usually grounded.

The commonly used Audio Precision analyzer is differential, but its ability to accurately reject fast pulses of 350ns width is questionable necessitating the on board measurement filter. When in doubt or when the signal needs to be single-ended, use an audio signal transformer to convert the differential output to a single ended output. Depending on the audio transformer's characteristics, there may be some attenuation of the audio signal which needs to be taken into account for correct measurement of performance.

Measurements made at the output of the measurement filter suffer attenuation relative to the primary, unfiltered outputs even at audio frequencies. This is due to the resistance of the inductors interacting with the termination resistor (300Ω) and is typically about -0.25dB (3%). In other words, the voltage levels (and corresponding power levels) indicated through the measurement filter are slightly lower than those that actually occur at the load placed on the unfiltered outputs. This small loss in the filter for measurement gives a lower output power reading than what is really occurring on the unfiltered outputs and its load.

LM4670 DSBGA BOARD ARTWORK

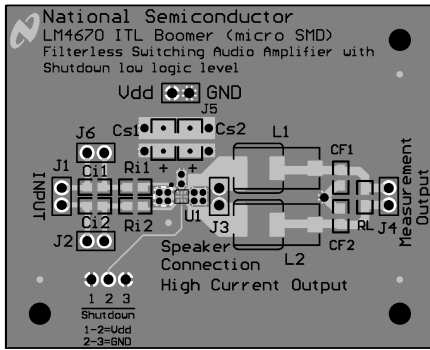

Figure 33. Composite View

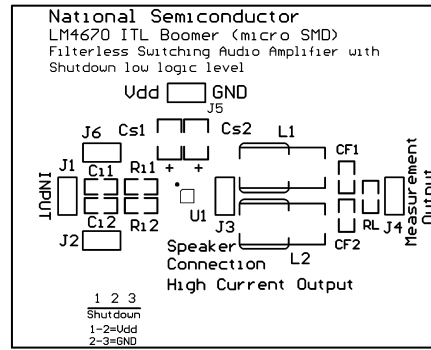

Figure 34. Silk Screen

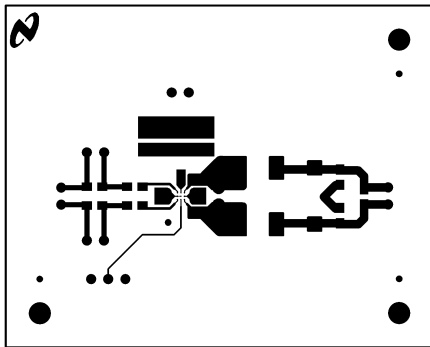

Figure 35. Top Layer

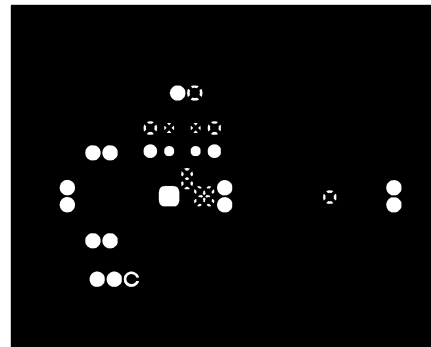

Figure 36. Internal Layer 1, GND

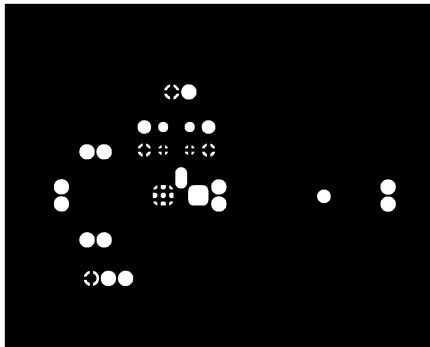

Figure 37. Internal Layer 2, V_{DD}

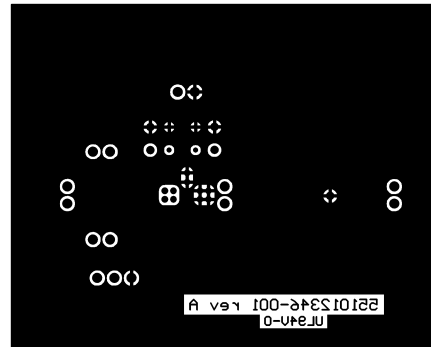

Figure 38. Bottom Layer

LM4670 WSON BOARD ARTWORK

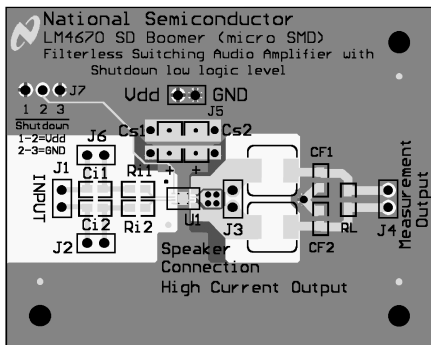

Figure 39. Composite View

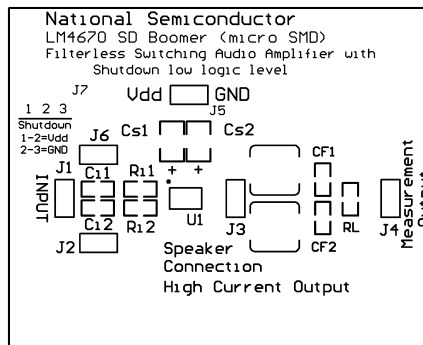

Figure 40. Silk Screen

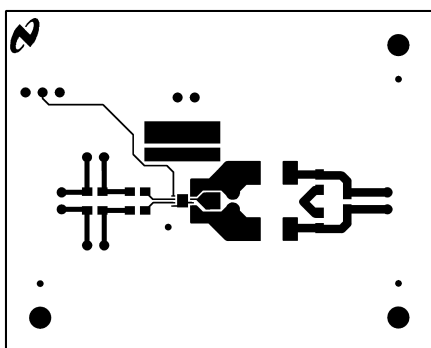

Figure 41. Top Layer

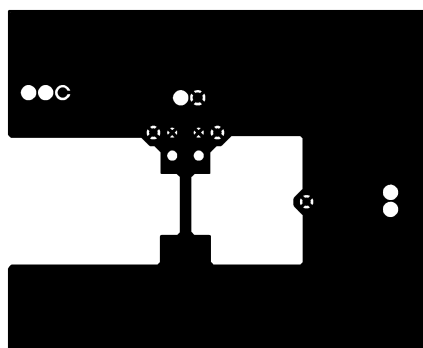

Figure 42. Internal Layer 1, GND

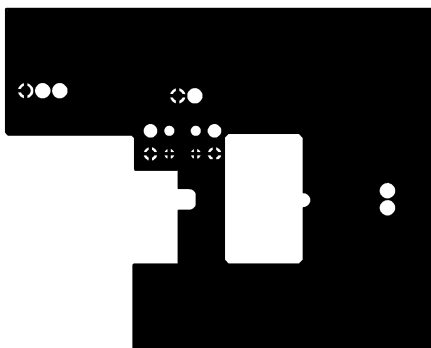

Figure 43. Internal Layer 2, V_{DD}

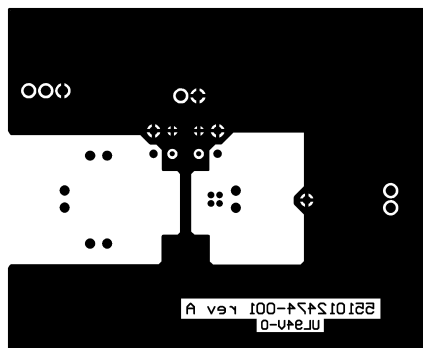

Figure 44. Bottom Layer

Revision History

Rev	Date	Description
1.0	12/15/04	Initial WEB of the D/S (TL pkg).
1.1	7/06/05	Re-released D/S to the WEB (added the SD package).
1.2	7/13/06	Edited Note 9, then re-released D/S to the WEB.
C	5/02/13	Changed layout of National Data Sheet to TI format

PACKAGING INFORMATION

Orderable Device	Status (1)	Package Type	Package Drawing	Pins	Package Qty	Eco Plan (2)	Lead/Ball Finish (6)	MSL Peak Temp (3)	Op Temp (°C)	Device Marking (4/5)	Samples
LM4670ITL/NOPB	ACTIVE	DSBGA	YZR	9	250	Green (RoHS & no Sb/Br)	SNAGCU	Level-1-260C-UNLIM	-40 to 85	G E6	Samples
LM4670ITLX/NOPB	ACTIVE	DSBGA	YZR	9	3000	Green (RoHS & no Sb/Br)	SNAGCU	Level-1-260C-UNLIM	-40 to 85	G E6	Samples
LM4670SD/NOPB	ACTIVE	WSON	NGQ	8	1000	Green (RoHS & no Sb/Br)	CU SN	Level-1-260C-UNLIM	-40 to 85	L4670	Samples

(1) The marketing status values are defined as follows:

ACTIVE: Product device recommended for new designs.

LIFEBUY: TI has announced that the device will be discontinued, and a lifetime-buy period is in effect.

NRND: Not recommended for new designs. Device is in production to support existing customers, but TI does not recommend using this part in a new design.

PREVIEW: Device has been announced but is not in production. Samples may or may not be available.

OBsolete: TI has discontinued the production of the device.

(2) Eco Plan - The planned eco-friendly classification: Pb-Free (RoHS), Pb-Free (RoHS Exempt), or Green (RoHS & no Sb/Br) - please check <http://www.ti.com/productcontent> for the latest availability information and additional product content details.

TBD: The Pb-Free/Green conversion plan has not been defined.

Pb-Free (RoHS): TI's terms "Lead-Free" or "Pb-Free" mean semiconductor products that are compatible with the current RoHS requirements for all 6 substances, including the requirement that lead not exceed 0.1% by weight in homogeneous materials. Where designed to be soldered at high temperatures, TI Pb-Free products are suitable for use in specified lead-free processes.

Pb-Free (RoHS Exempt): This component has a RoHS exemption for either 1) lead-based flip-chip solder bumps used between the die and package, or 2) lead-based die adhesive used between the die and leadframe. The component is otherwise considered Pb-Free (RoHS compatible) as defined above.

Green (RoHS & no Sb/Br): TI defines "Green" to mean Pb-Free (RoHS compatible), and free of Bromine (Br) and Antimony (Sb) based flame retardants (Br or Sb do not exceed 0.1% by weight in homogeneous material)

(3) MSL, Peak Temp. - The Moisture Sensitivity Level rating according to the JEDEC industry standard classifications, and peak solder temperature.

(4) There may be additional marking, which relates to the logo, the lot trace code information, or the environmental category on the device.

(5) Multiple Device Markings will be inside parentheses. Only one Device Marking contained in parentheses and separated by a "~" will appear on a device. If a line is indented then it is a continuation of the previous line and the two combined represent the entire Device Marking for that device.

(6) Lead/Ball Finish - Orderable Devices may have multiple material finish options. Finish options are separated by a vertical ruled line. Lead/Ball Finish values may wrap to two lines if the finish value exceeds the maximum column width.

Important Information and Disclaimer: The information provided on this page represents TI's knowledge and belief as of the date that it is provided. TI bases its knowledge and belief on information provided by third parties, and makes no representation or warranty as to the accuracy of such information. Efforts are underway to better integrate information from third parties. TI has taken and

continues to take reasonable steps to provide representative and accurate information but may not have conducted destructive testing or chemical analysis on incoming materials and chemicals. TI and TI suppliers consider certain information to be proprietary, and thus CAS numbers and other limited information may not be available for release.

In no event shall TI's liability arising out of such information exceed the total purchase price of the TI part(s) at issue in this document sold by TI to Customer on an annual basis.

TAPE AND REEL INFORMATION

QUADRANT ASSIGNMENTS FOR PIN 1 ORIENTATION IN TAPE

*All dimensions are nominal

Device	Package Type	Package Drawing	Pins	SPQ	Reel Diameter (mm)	Reel Width W1 (mm)	A0 (mm)	B0 (mm)	K0 (mm)	P1 (mm)	W (mm)	Pin1 Quadrant
LM4670ITL/NOPB	DSBGA	YZR	9	250	178.0	8.4	1.57	1.57	0.76	4.0	8.0	Q1
LM4670ITLX/NOPB	DSBGA	YZR	9	3000	178.0	8.4	1.57	1.57	0.76	4.0	8.0	Q1
LM4670SD/NOPB	WSOSON	NGQ	8	1000	178.0	12.4	3.3	3.3	1.0	8.0	12.0	Q1

TAPE AND REEL BOX DIMENSIONS

*All dimensions are nominal

Device	Package Type	Package Drawing	Pins	SPQ	Length (mm)	Width (mm)	Height (mm)
LM4670ITL/NOPB	DSBGA	YZR	9	250	210.0	185.0	35.0
LM4670ITLX/NOPB	DSBGA	YZR	9	3000	210.0	185.0	35.0
LM4670SD/NOPB	WSON	NGQ	8	1000	210.0	185.0	35.0

YZR0009

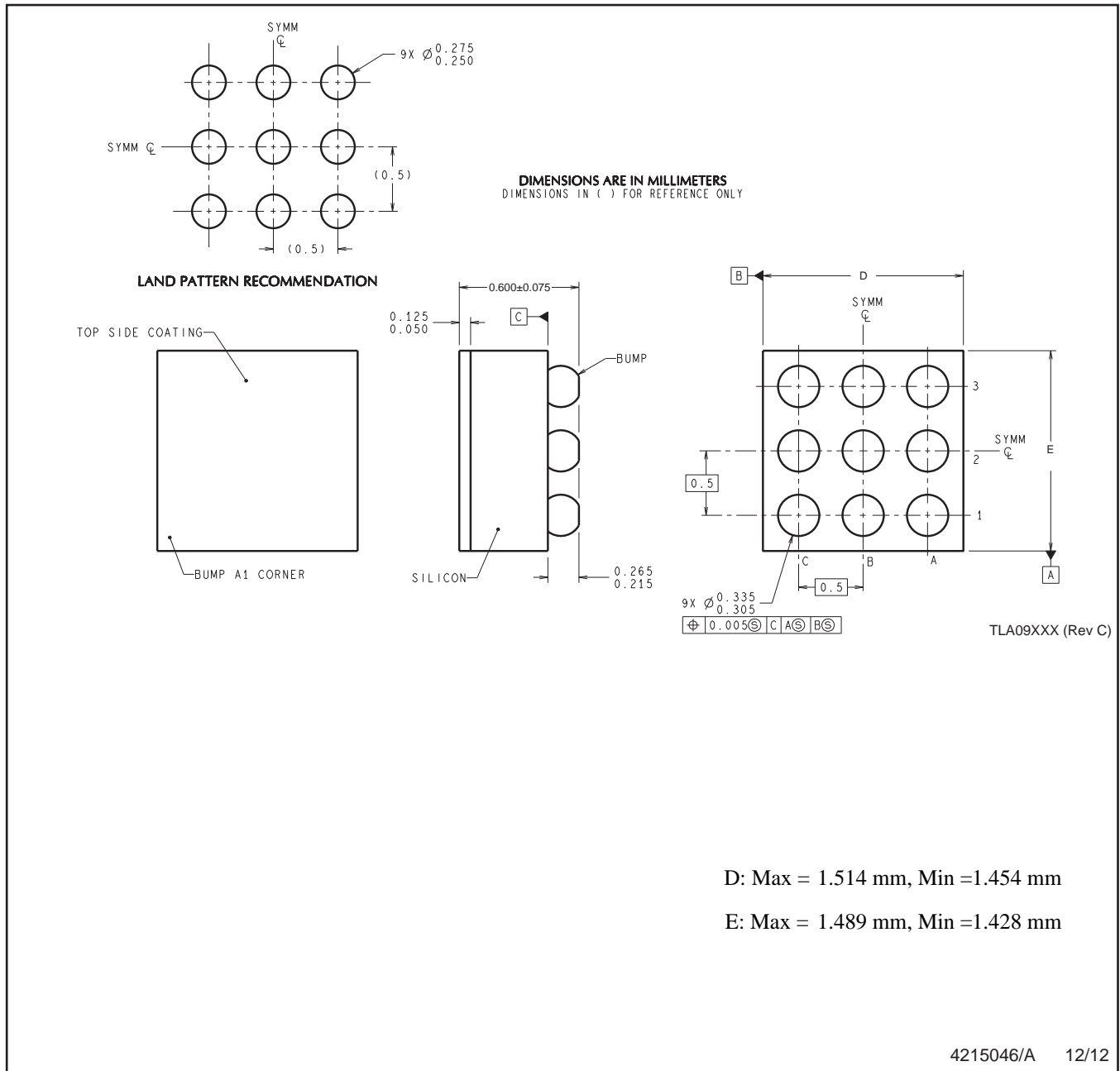

NOTES: A. All linear dimensions are in millimeters. Dimensioning and tolerancing per ASME Y14.5M-1994.
B. This drawing is subject to change without notice.

EXAMPLE BOARD LAYOUT

NGQ0008A

WSON - 0.8 mm max height

PLASTIC SMALL OUTLINE - NO LEAD

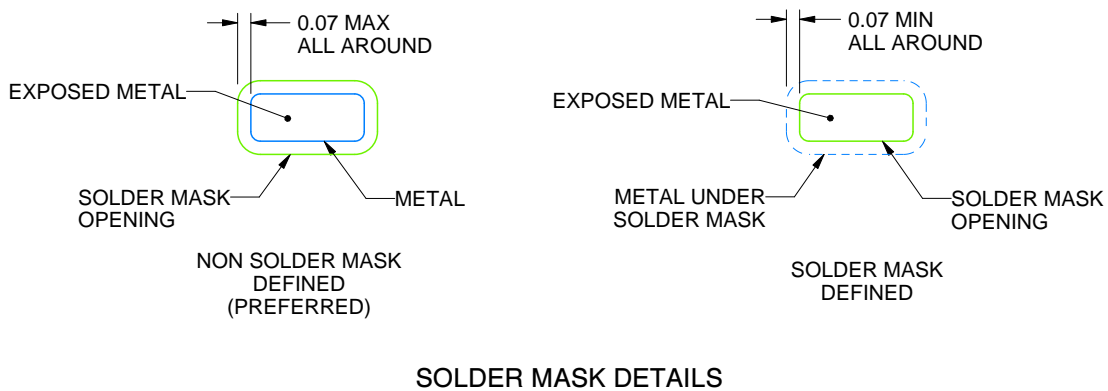
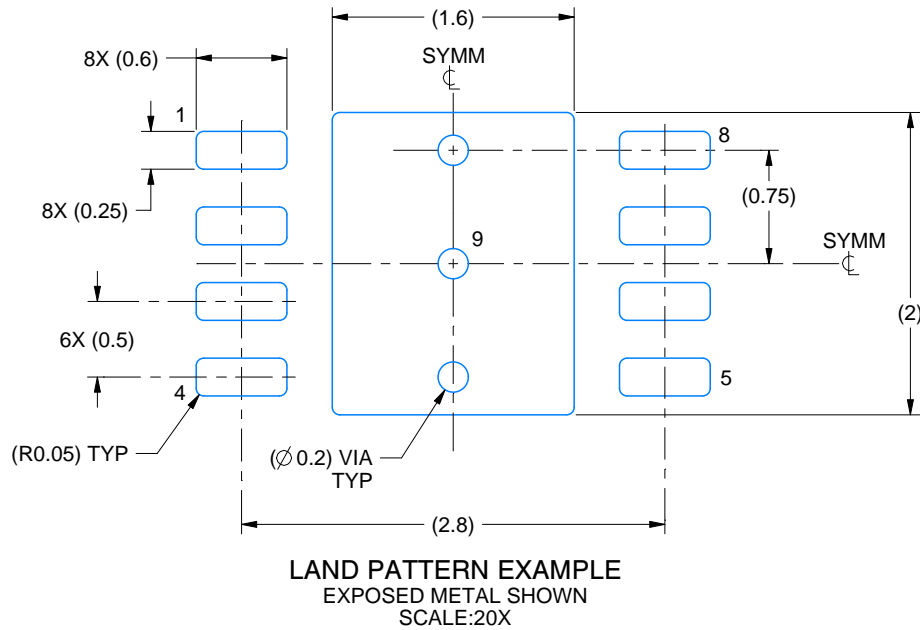

4214922/A 03/2018

NOTES: (continued)

- This package is designed to be soldered to a thermal pad on the board. For more information, see Texas Instruments literature number SLUA271 (www.ti.com/lit/slua271).
- Vias are optional depending on application, refer to device data sheet. If any vias are implemented, refer to their locations shown on this view. It is recommended that vias under paste be filled, plugged or tented.

EXAMPLE STENCIL DESIGN

NGQ0008A

WSON - 0.8 mm max height

PLASTIC SMALL OUTLINE - NO LEAD

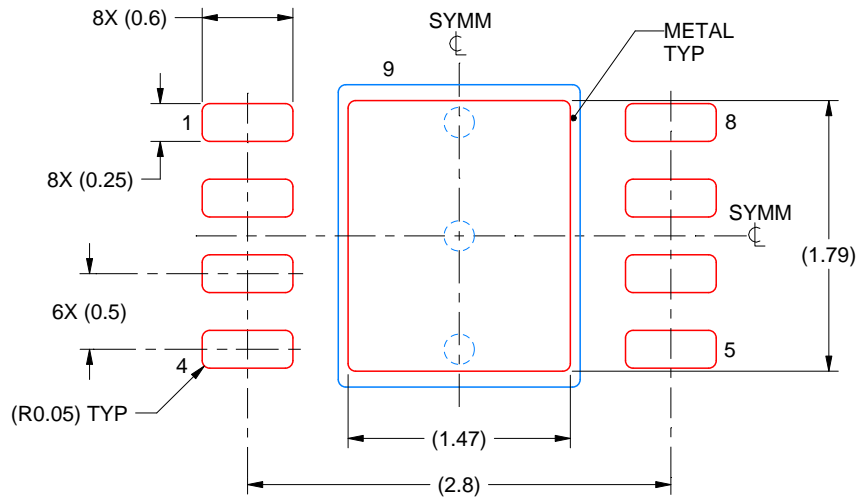

SOLDER PASTE EXAMPLE
BASED ON 0.1 mm THICK STENCIL

EXPOSED PAD 9:
82% PRINTED SOLDER COVERAGE BY AREA UNDER PACKAGE
SCALE:20X

4214922/A 03/2018

NOTES: (continued)

6. Laser cutting apertures with trapezoidal walls and rounded corners may offer better paste release. IPC-7525 may have alternate design recommendations.

IMPORTANT NOTICE

Texas Instruments Incorporated (TI) reserves the right to make corrections, enhancements, improvements and other changes to its semiconductor products and services per JESD46, latest issue, and to discontinue any product or service per JESD48, latest issue. Buyers should obtain the latest relevant information before placing orders and should verify that such information is current and complete.

TI's published terms of sale for semiconductor products (<http://www.ti.com/sc/docs/stdterms.htm>) apply to the sale of packaged integrated circuit products that TI has qualified and released to market. Additional terms may apply to the use or sale of other types of TI products and services.

Reproduction of significant portions of TI information in TI data sheets is permissible only if reproduction is without alteration and is accompanied by all associated warranties, conditions, limitations, and notices. TI is not responsible or liable for such reproduced documentation. Information of third parties may be subject to additional restrictions. Resale of TI products or services with statements different from or beyond the parameters stated by TI for that product or service voids all express and any implied warranties for the associated TI product or service and is an unfair and deceptive business practice. TI is not responsible or liable for any such statements.

Buyers and others who are developing systems that incorporate TI products (collectively, "Designers") understand and agree that Designers remain responsible for using their independent analysis, evaluation and judgment in designing their applications and that Designers have full and exclusive responsibility to assure the safety of Designers' applications and compliance of their applications (and of all TI products used in or for Designers' applications) with all applicable regulations, laws and other applicable requirements. Designer represents that, with respect to their applications, Designer has all the necessary expertise to create and implement safeguards that (1) anticipate dangerous consequences of failures, (2) monitor failures and their consequences, and (3) lessen the likelihood of failures that might cause harm and take appropriate actions. Designer agrees that prior to using or distributing any applications that include TI products, Designer will thoroughly test such applications and the functionality of such TI products as used in such applications.

TI's provision of technical, application or other design advice, quality characterization, reliability data or other services or information, including, but not limited to, reference designs and materials relating to evaluation modules, (collectively, "TI Resources") are intended to assist designers who are developing applications that incorporate TI products; by downloading, accessing or using TI Resources in any way, Designer (individually or, if Designer is acting on behalf of a company, Designer's company) agrees to use any particular TI Resource solely for this purpose and subject to the terms of this Notice.

TI's provision of TI Resources does not expand or otherwise alter TI's applicable published warranties or warranty disclaimers for TI products, and no additional obligations or liabilities arise from TI providing such TI Resources. TI reserves the right to make corrections, enhancements, improvements and other changes to its TI Resources. TI has not conducted any testing other than that specifically described in the published documentation for a particular TI Resource.

Designer is authorized to use, copy and modify any individual TI Resource only in connection with the development of applications that include the TI product(s) identified in such TI Resource. NO OTHER LICENSE, EXPRESS OR IMPLIED, BY ESTOPPEL OR OTHERWISE TO ANY OTHER TI INTELLECTUAL PROPERTY RIGHT, AND NO LICENSE TO ANY TECHNOLOGY OR INTELLECTUAL PROPERTY RIGHT OF TI OR ANY THIRD PARTY IS GRANTED HEREIN, including but not limited to any patent right, copyright, mask work right, or other intellectual property right relating to any combination, machine, or process in which TI products or services are used. Information regarding or referencing third-party products or services does not constitute a license to use such products or services, or a warranty or endorsement thereof. Use of TI Resources may require a license from a third party under the patents or other intellectual property of the third party, or a license from TI under the patents or other intellectual property of TI.

TI RESOURCES ARE PROVIDED "AS IS" AND WITH ALL FAULTS. TI DISCLAIMS ALL OTHER WARRANTIES OR REPRESENTATIONS, EXPRESS OR IMPLIED, REGARDING RESOURCES OR USE THEREOF, INCLUDING BUT NOT LIMITED TO ACCURACY OR COMPLETENESS, TITLE, ANY EPIDEMIC FAILURE WARRANTY AND ANY IMPLIED WARRANTIES OF MERCHANTABILITY, FITNESS FOR A PARTICULAR PURPOSE, AND NON-INFRINGEMENT OF ANY THIRD PARTY INTELLECTUAL PROPERTY RIGHTS. TI SHALL NOT BE LIABLE FOR AND SHALL NOT DEFEND OR INDEMNIFY DESIGNER AGAINST ANY CLAIM, INCLUDING BUT NOT LIMITED TO ANY INFRINGEMENT CLAIM THAT RELATES TO OR IS BASED ON ANY COMBINATION OF PRODUCTS EVEN IF DESCRIBED IN TI RESOURCES OR OTHERWISE. IN NO EVENT SHALL TI BE LIABLE FOR ANY ACTUAL, DIRECT, SPECIAL, COLLATERAL, INDIRECT, PUNITIVE, INCIDENTAL, CONSEQUENTIAL OR EXEMPLARY DAMAGES IN CONNECTION WITH OR ARISING OUT OF TI RESOURCES OR USE THEREOF, AND REGARDLESS OF WHETHER TI HAS BEEN ADVISED OF THE POSSIBILITY OF SUCH DAMAGES.

Unless TI has explicitly designated an individual product as meeting the requirements of a particular industry standard (e.g., ISO/TS 16949 and ISO 26262), TI is not responsible for any failure to meet such industry standard requirements.

Where TI specifically promotes products as facilitating functional safety or as compliant with industry functional safety standards, such products are intended to help enable customers to design and create their own applications that meet applicable functional safety standards and requirements. Using products in an application does not by itself establish any safety features in the application. Designers must ensure compliance with safety-related requirements and standards applicable to their applications. Designer may not use any TI products in life-critical medical equipment unless authorized officers of the parties have executed a special contract specifically governing such use. Life-critical medical equipment is medical equipment where failure of such equipment would cause serious bodily injury or death (e.g., life support, pacemakers, defibrillators, heart pumps, neurostimulators, and implantables). Such equipment includes, without limitation, all medical devices identified by the U.S. Food and Drug Administration as Class III devices and equivalent classifications outside the U.S.

TI may expressly designate certain products as completing a particular qualification (e.g., Q100, Military Grade, or Enhanced Product). Designers agree that it has the necessary expertise to select the product with the appropriate qualification designation for their applications and that proper product selection is at Designers' own risk. Designers are solely responsible for compliance with all legal and regulatory requirements in connection with such selection.

Designer will fully indemnify TI and its representatives against any damages, costs, losses, and/or liabilities arising out of Designer's non-compliance with the terms and provisions of this Notice.

Looking for pricing, stock, or lifecycle information?

Click below to explore more details on WIN SOURCE:

 [View LM4670SDX/NOPB on WIN SOURCE](#)

 [Texas Instruments](#) Information

Optimize Your Supply Chain with WIN SOURCE Solutions

-  Global Sourcing Solution
-  Obsolete Management
-  Cost Control Management
-  Shortage Management
-  Alternative Solution
-  Excess Inventory Management