



**THE DATASHEET OF
EKK-LM3S8962**



Stellaris® LM3S8962 Evaluation Board

User's Manual



Copyright

Copyright © 2007–2010 Texas Instruments, Inc. All rights reserved. Stellaris and StellarisWare are registered trademarks of Texas Instruments. ARM and Thumb are registered trademarks, and Cortex is a trademark of ARM Limited. Other names and brands may be claimed as the property of others.

Texas Instruments
108 Wild Basin, Suite 350
Austin, TX 78746
<http://www.ti.com/stellaris>



Table of Contents

Chapter 1: Stellaris® LM3S8962 Evaluation Board Overview	9
Features.....	10
Block Diagram	11
Evaluation Kit Contents	12
Evaluation Board Specifications	12
Features of the LM3S8962 Microcontroller.....	12
Chapter 2: LM3S8962 Evaluation Board Hardware Description.....	15
LM3S8962 Evaluation Board	15
LM3S8962 Microcontroller Overview	15
Ethernet	15
CAN Module.....	15
Clocking	15
Reset.....	16
Power Supplies	16
Debugging.....	16
USB Device Controller Functions	17
USB Overview.....	17
USB to JTAG/SWD	17
Virtual COM Port.....	17
Serial Wire Out.....	17
Organic LED Display	18
Features.....	18
Control Interface	18
Power Supply.....	18
Design Guidelines.....	18
Further Reference.....	18
Other Peripherals.....	18
Speaker.....	18
MicroSD Card Slot	19
Push Switches	19
User LED	19
Bypassing Peripherals	19
Interfacing to the EVB.....	20
Using the In-Circuit Debugger Interface	20
Chapter 3: CAN Device Board Hardware Description	21
Device Overview	21
Power Supply.....	21
Programming and Debugging	21
Interfacing	21
Appendix A: Schematics.....	23
Appendix B: Connection Details	29
Component Locations.....	30

Evaluation Board Dimensions.....	31
I/O Breakout Pads	32
LM3S2110 CAN Device Board Connections	33
Recommended Connectors	33
ARM Target Pinout	34
References	35

List of Tables

Table 2-1. Stellaris LM3S8962 Evaluation Board Hardware Debugging Configurations.....	16
Table 2-2. Isolating On-Board Hardware.....	19
Table B-1. I/O Breakout Pads.....	32
Table B-2. Recommended Connectors.....	33
Table B-3. 20-Pin JTAG/SWD Configuration.....	34

List of Figures

Figure 1-1. Stellaris LM3S8962 Evaluation Board Layout	9
Figure 1-2. Stellaris LM3S2110 CAN Device Board	10
Figure 1-3. LM3S8962 Evaluation Board Block Diagram	11
Figure 1-4. LM3S2110 CAN Device Block Diagram	11
Figure 2-1. ICD Interface Mode	20
Figure B-1. LM3S8962 Evaluation Board Component Locations.....	30
Figure B-2. LM3S8962 Evaluation Board Dimensions.....	31
Figure B-3. LM3S2110 CAN Device Board Dimensions	31

Stellaris® LM3S8962 Evaluation Board Overview

The Stellaris® LM3S8962 Evaluation Board is a compact and versatile evaluation platform for the Stellaris LM3S8962 ARM® Cortex™-M3-based microcontroller. The evaluation kit design highlights the LM3S8962 microcontroller's integrated CAN and 10/100 Ethernet controllers.

As well as implementing an embedded web server, the kit functions as a complete controller area network (CAN) by providing two boards each with a Stellaris microcontroller. The main evaluation board (EVB) is the CAN host. A small CAN device board, linked with a ribbon cable, uses a Stellaris LM3S2110 microcontroller. The function of each board is fully configurable in software.

You can use the EVB either as an evaluation platform or as a low-cost in-circuit debug interface (ICDI). In debug interface mode, the on-board microcontroller is bypassed, allowing connection of the debug signals to an external Stellaris microcontroller target. The kit is also compatible with high-performance external JTAG debuggers.

This evaluation kit enables quick evaluation, prototype development, and creation of application-specific designs for Ethernet and CAN networks. The kit also includes extensive source-code examples, allowing you to start building C code applications quickly.

Figure 1-1. Stellaris LM3S8962 Evaluation Board Layout

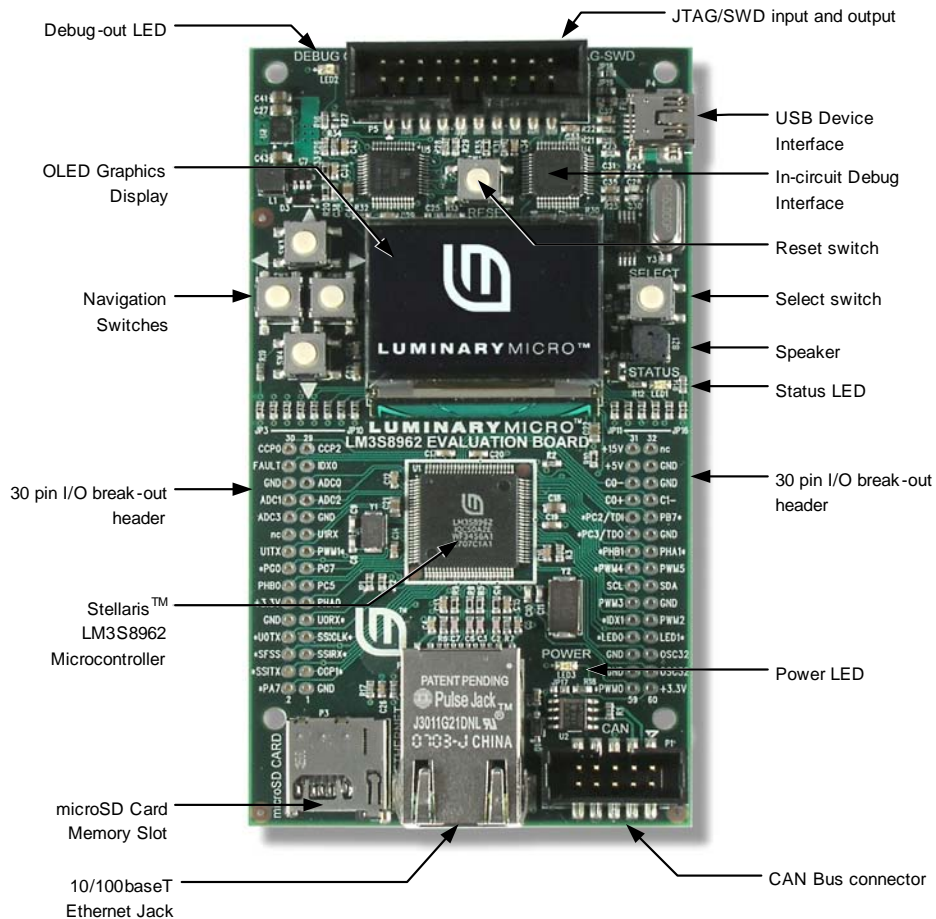
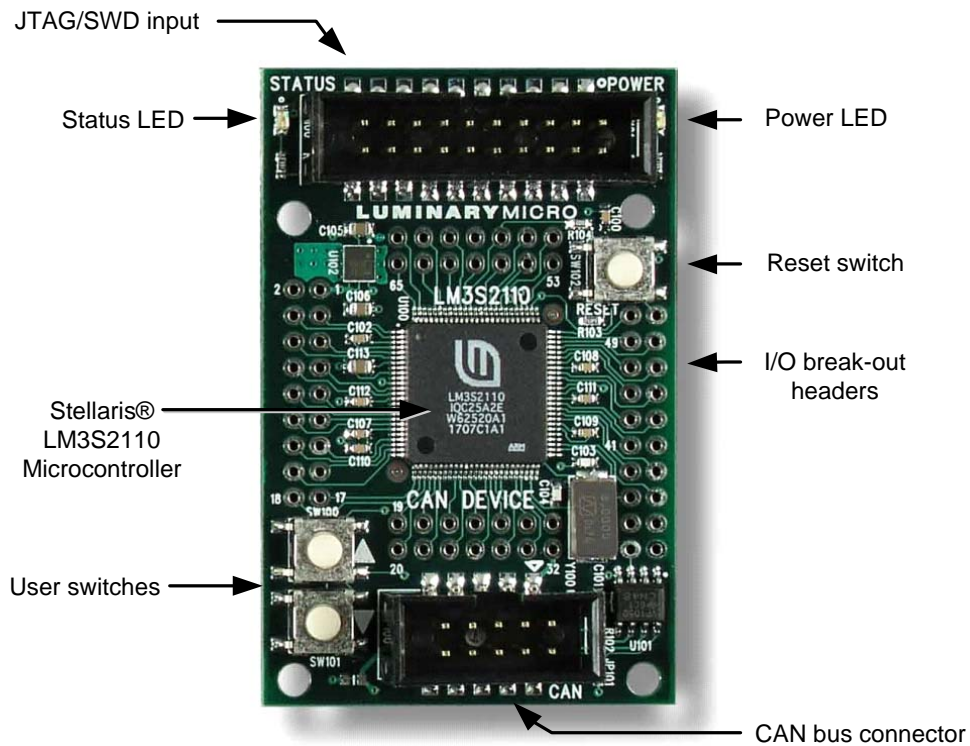

Figure 1-2. Stellaris LM3S2110 CAN Device Board



Features

The Stellaris LM3S8962 Evaluation Kit includes the following features:

- Stellaris LM3S8962 microcontroller with fully-integrated 10/100 embedded Ethernet controller and CAN module
- Simple setup; USB cable provides serial communication, debugging, and power
- OLED graphics display with 128 x 96 pixel resolution
- User LED, navigation switches, and select pushbuttons
- Magnetic speaker
- MicroSD card slot
- USB interface for debugging and power supply
- Standard ARM® 20-pin JTAG debug connector with input and output modes
- LM3S8962 I/O available on labeled break-out pads
- Standalone CAN device board using Stellaris LM3S2110 microcontroller

Block Diagram

Figure 1-3. LM3S8962 Evaluation Board Block Diagram

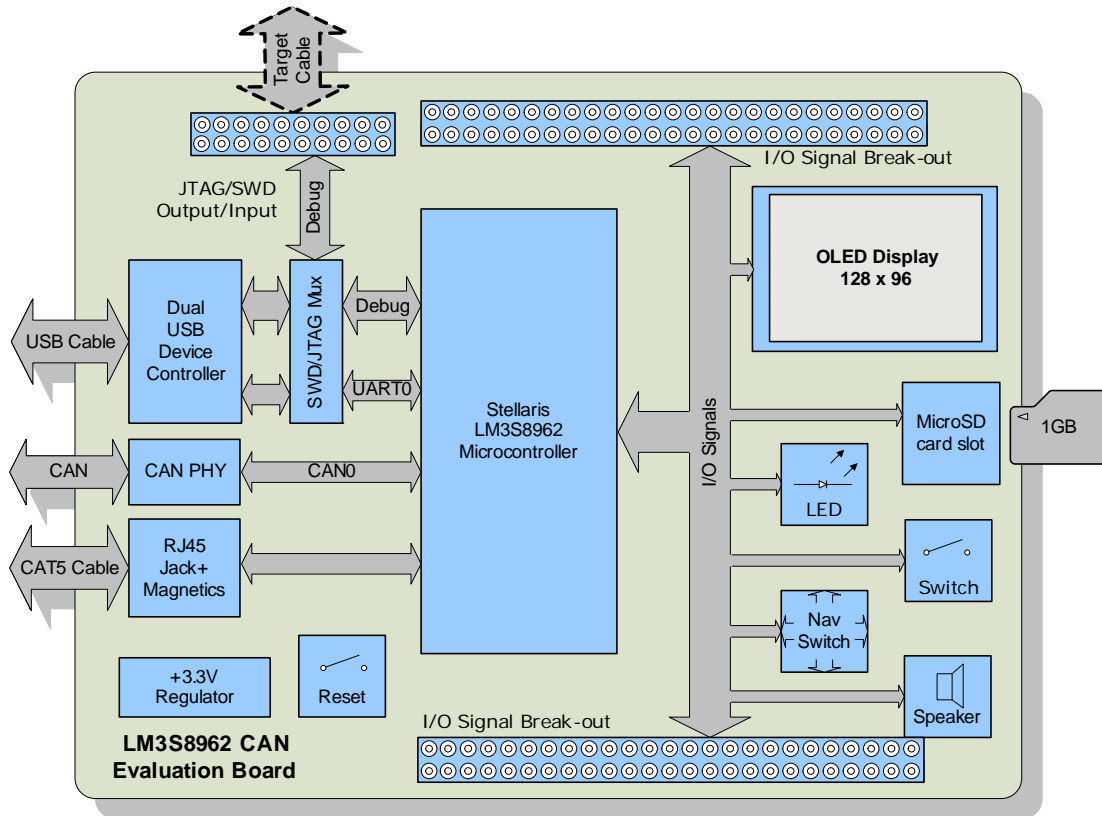
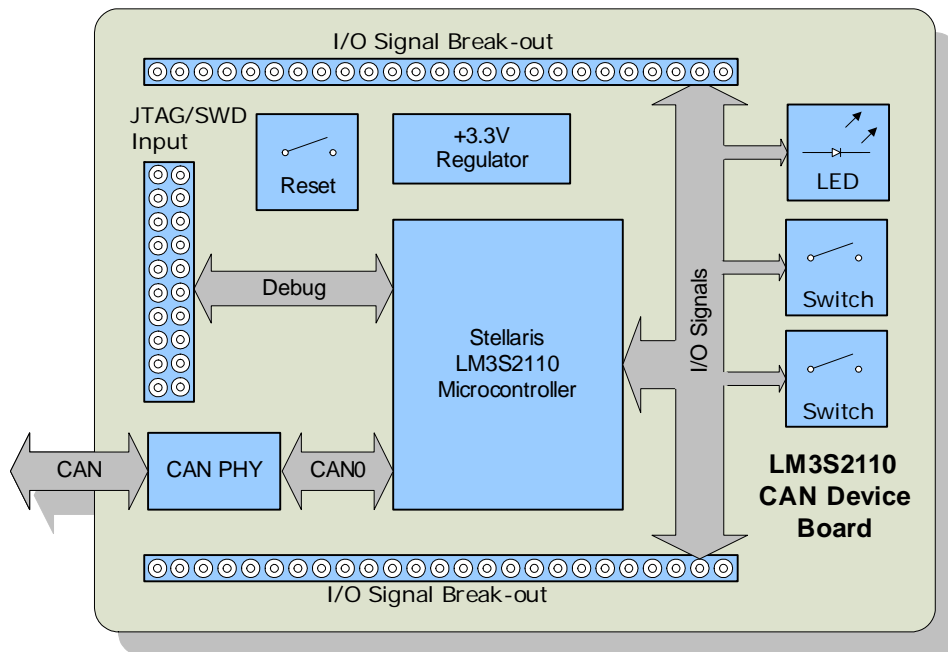

Figure 1-4. LM3S2110 CAN Device Block Diagram



Evaluation Kit Contents

The evaluation kit contains everything needed to develop and run applications for Stellaris microcontrollers including:

- LM3S8962 evaluation board (EVB)
- LM3S2110 CAN device board
- USB cable
- 20-pin JTAG/SWD target cable
- 10-pin CAN cable
- CD containing:
 - A supported version of one of the following (including a toolchain-specific Quickstart guide):
 - Keil™ RealView® Microcontroller Development Kit (MDK-ARM)
 - IAR Embedded Workbench
 - Code Sourcery GCC development tools
 - Code Red Technologies development tools
 - Texas Instruments' Code Composer Studio™ IDE
 - Complete documentation
 - Quickstart application source code
 - Stellaris® Firmware Development Package with example source code

Evaluation Board Specifications

- Board supply voltage: 4.37–5.25 V_{dc} from USB connector
- Board supply current: 240 mA typ (fully active, CPU at 50 MHz)
- Break-out power output: 3.3 V_{dc} (60 mA max), 15 V_{dc} (15 mA max)
- Dimensions: 4.55" x 2.45" x 0.7" (L x W x H)
- RoHS status: Compliant

Features of the LM3S8962 Microcontroller

- 32-bit RISC performance using ARM® Cortex™-M3 v7M architecture
 - 50-MHz operation
 - Hardware-division and single-cycle-multiplication
 - Memory protection unit (MPU), provides a privileged mode for protected operating system functionality
 - Integrated Nested Vectored Interrupt Controller (NVIC)
 - 42 interrupt channels with eight priority levels
- 256-KB single-cycle Flash
- 64-KB single-cycle SRAM

- Four general-purpose 32-bit timers
- Integrated Ethernet MAC and PHY
- Controller area network (CAN) module
- Three fully programmable 16C550-type UARTs
- Four 10-bit ADC channels (inputs) when used as single-ended inputs
- One integrated analog comparator
- One I²C module
- Two PWM generator blocks
 - One 16-bit counter
 - Two comparators
 - Produces two independent PWM signals
 - One dead-band generator
- Two QEI modules with position integrator for tracking encoder position
- Two synchronous serial interfaces (SSIs)
- 0 to 42 GPIOs, depending on user configuration
- On-chip low drop-out (LDO) voltage regulator

LM3S8962 Evaluation Board Hardware Description

In addition to a microcontroller, the Stellaris LM3S8962 evaluation board includes a range of useful peripherals and an integrated in-circuit debug interface (ICDI). This chapter describes how these peripherals operate and interface to the microcontroller.

LM3S8962 Evaluation Board

LM3S8962 Microcontroller Overview

The heart of the EVB is a Stellaris LM3S8962 ARM Cortex-M3-based microcontroller. The LM3S8962 offers 256-KB Flash memory, 50-MHz operation, an Ethernet controller, a CAN module, and a wide range of peripherals. Refer to the LM3S8962 data sheet (order number DS-LM3S8962) for complete device details.

The LM3S8962 microcontroller is factory-programmed with a quickstart demo program. The quickstart program resides in the LM3S8962 on-chip Flash memory and runs each time power is applied, unless the quickstart has been replaced with a user program.

Ethernet

A key feature of the LM3S8962 microcontroller is its fully integrated Ethernet controller. Only an RJ45 jack with integrated magnetics and a few passive components are needed to complete the 10/100baseT interface. The RJ45 jack incorporates LEDs that indicate traffic and link status. These are automatically managed by on-chip microcontroller hardware. Alternatively, the LEDs can be software-controlled by configuring those pins as general-purpose outputs.

The LM3S8962 supports automatic MDI/MDI-X so the EVB can connect directly to a network or to another Ethernet device without requiring a cross-over cable.

CAN Module

A CAN module enables highly reliable communications at up to 1 Mbits/s. The LM3S8962 evaluation board includes a standard CAN transceiver and a 10-pin CAN connector whose signal assignments follow a commonly used CAN standard. A simple adaptor (not included in the kit) can be used to allow the use of standard DB-9 CAN cables (as specified by CAN in Automation CiA DS102).

An on-board 120-ohm resistor provides bus termination. This resistor can be removed if the board is not a network endpoint.

The CAN transceiver is configured in hardware to support speeds up to 1 Mbits/s. A resistor can be added to reduce the transceiver's drive slew-rate for slower data rates over longer distances.

Clocking

The LM3S8962 microcontroller has four on-chip oscillators, three are implemented on the EVB. An internal 12 MHz oscillator is the clock source the microcontroller uses during and following POR. An 8.0-MHz crystal completes the LM3S8962's main internal clock circuit. An internal PLL, configured in software, multiplies this clock to 50-MHz for core and peripheral timing. The internal 12MHz oscillator is the primary clock source during start-up.

A small, 25-MHz crystal is used by the LM3S8962 microcontroller for Ethernet physical layer timing and is independent of the main oscillator.

Reset

The LM3S8962 microcontroller shares its external reset input with the OLED display. In the EVB, reset sources are gated through the CPLD, though in a typical application a simple wired-OR arrangement is sufficient.

External reset is asserted (active low) under any one of three conditions:

- Power-on reset
- Reset push switch SW1 held down
- Internal debug mode—By the USB device controller (U4 FT2232) when instructed by debugger

Power Supplies

The LM3S8962 is powered from a +3.3-V supply. A low drop-out (LDO) regulator regulates +5-V power from the USB cable to +3.3-V. +3.3-V power is available for powering external circuits.

A +15-V rail is available when the OLED display power supply is active. The speaker and the OLED display boost-converter operate from the +5-V rail.

Debugging

Stellaris microcontrollers support programming and debugging using either JTAG or SWD. JTAG uses the signals TCK, TMS, TDI, and TDO. SWD requires fewer signals (SWCLK, SWDIO, and, optionally, SWO for trace). The debugger determines which debug protocol is used.

Debugging Modes

The LM3S8962 evaluation board supports a range of hardware debugging configurations. Table 2-1 summarizes these configurations.

Table 2-1. Stellaris LM3S8962 Evaluation Board Hardware Debugging Configurations

Mode	Debug Function	Use	Selected by
1	Internal ICDI	Debug on-board LM3S8962 microcontroller over USB interface.	Default mode
2	ICDI out to JTAG/SWD header	The EVB is used as a USB to SWD/JTAG interface to an external target.	Connecting to an external target and starting debug software. The red Debug Out LED will be ON.
3	In from JTAG/SWD header	For users who prefer an external debug interface (ULINK, JLINK, etc.) with the EVB.	Connecting an external debugger to the JTAG/SWD header.

Modes 2 and 3 automatically detect the presence of an external debug cable. When the debugger software is connected to the EVB's USB controller, the EVB automatically selects Mode 2 and illuminates the red Debug Out LED.

Debug In Considerations

Debug Mode 3 supports evaluation board debugging using an external debug interface. Mode 3 is automatically selected when a device such as a Segger J-Link or Keil ULINK is connected.

Boards marked Revision B or later automatically configure pin 1 to be a 3.3-V reference, if an external debugger is connected. To determine the revision of your board, locate the product number on the bottom of the board; for example, EK-LM3S8962-B. The last character of the product number identifies the board revision.

A configuration or board-level change may be necessary when using an external debug interface with revision A of this evaluation board. Because the evaluation board supports both debug out and debug in modes, pin 1 of the 20-pin JTAG/SWD header is, by default, not connected to +3.3 V. Consequently, devices requiring a voltage on pin 1 to power their line buffers may not work.

Two solutions exist. Some debugger interfaces (such as ULINK) have an internal power jumper that, in this case, should be set to internal +3.3 V power. Refer to debugger interface documentation for full details. However, if your debugger interface does not have a selectable power source, it may be necessary to install a 0- Ω resistor on the evaluation board to route power to pin 1. Refer to the schematics and board drawing in the appendix of this manual for the location of this resistor.

USB Device Controller Functions

USB Overview

An FT2232 device from Future Technology Devices International Ltd. manages USB-to-serial conversion. The FT2232 is factory-configured to implement a JTAG/SWD port (synchronous serial) on channel A and a Virtual COM Port (VCP) on channel B. This feature allows two simultaneous communications links between the host computer and the target device using a single USB cable. Separate Windows drivers for each function are provided on the Documentation and Software CD.

A small serial EEPROM holds the FT2232 configuration data. The EEPROM is not accessible by the LM3S8962 microcontroller.

For full details on FT2232 operation, go to www.ftdichip.com.

USB to JTAG/SWD

The FT2232 USB device performs JTAG/SWD serial operations under the control of the debugger. A CPLD (U6) multiplexes SWD and JTAG functions and, when working in SWD mode, provides direction control for the bidirectional data line. The CPLD also implements logic to select between the three debug modes. The internal or external target selection is determined by multiplexing $\overline{TCK}/\overline{SWCLK}$ and asserting \overline{TRST} .

Virtual COM Port

The Virtual COM Port (VCP) allows Windows applications (such as HyperTerminal) to communicate with `UART0` on the LM3S8962 over USB. Once the FT2232 VCP driver is installed, Windows assigns a COM port number to the VCP channel.

Serial Wire Out

The evaluation board supports the Cortex-M3 serial-wire output (SWO) trace capabilities. Under debugger control, the CPLD can route the SWO datastream to the virtual communication port (VCP) transmit channel. The debugger can then decode and interpret the trace information

received from the VCP. The normal VCP connection to `UART0` is interrupted when using SWO. Not all debuggers support SWO. Refer to the Stellaris LM3S8962 data sheet for additional information on the trace port interface unit (TPIU).

Organic LED Display

The EVB features an Organic LED (OLED) graphics display with 128 x 96 pixel resolution. OLED is a new technology that offers many advantages over LCD display technology. The display is protected by a thin protective plastic film. If desired the film can be removed using a pair of tweezers.

Features

- RiT P14201 series display
- 128 columns by 96 rows
- High-contrast (typ. 500:1)
- Excellent brightness (120 cd/m²)
- Fast 10 us response

Control Interface

The OLED display has a built-in controller IC with synchronous serial and parallel interfaces. Synchronous serial (SSI) is used on the EVB as it requires fewer microcontroller pins. Data cannot be read from the OLED controller; only one data line is necessary. Note that the SSI port is shared with the MicroSD card slot. The Stellaris® Firmware Development Package (included on the Documentation and Software CD) contains complete drivers with source-code for the OLED display.

Power Supply

A +15-V supply is needed to bias the OLED display. A FAN5331 device from Fairchild combines with a few external components to complete a boost converter. A GPIO (`PA7`) is assigned to turn on and off the controller as necessary for power rail sequencing. When the OLED display is operating, a small amount of power can be drawn from the +15-V rail to power other devices.

Design Guidelines

The OLED display has a lifetime of about 13,000 hours. It is also prone to degradation due to burn-in, similar to CRT and plasma displays. The quickstart application includes both a screen saver and a power-down mode to extend display life. These factors should be considered when developing EVB applications that use the OLED display.

Further Reference

For additional information on the RiT OLED display, visit www.ritekdisplay.com.

Other Peripherals

Speaker

A small, magnetic audio transducer connects through a MOSFET to `PG1/PWM1`, allowing a range of options for generating simple and complex tones. Use of the +5-V rail reduces switching noise on the +3.3-V rail.

MicroSD Card Slot

Removable Flash cards are an ideal media for storing data such as web page content. The source code on the CD includes example code for reading data from standard FAT-formatted SD cards. All data and control transactions use the SD card's SPI mode. Note that the SD card specification does not require that a card supports the SPI mode, but most cards do so in practice. Cards from several vendors have been used with the EVB.

MicroSD cards are very small and require careful handling. The SD card slot on the EVB is a push-push type (push to insert; push again to eject).

NOTE: To avoid damage, remove power before inserting or removing cards. The EVB does not implement SD card power control.

Push Switches

The EVB has five general-purpose input switches. Four are arranged in a navigation-style configuration. The fifth functions as a Select switch.

User LED

A user LED (LED1) is provided for general use. The LED is connected to PF0/PWM0, allowing the option of either GPIO or PWM control (brightness control). Refer to the Quickstart Application source code for an example of PWM control.

Bypassing Peripherals

Excluding Ethernet and CAN, the EVB's on-board peripheral circuits require 16 GPIO lines. Two additional GPIO lines are assigned to Ethernet LEDs. This leaves 20 GPIO lines and 4 ADC channels immediately available for connection to external circuits. If an application requires more GPIO lines, the on-board hardware can be disconnected. The EVB is populated with 16 jumper links, which can be cut with a knife to isolate on-board hardware. The process can be reversed by installing 0603- 0-ohm chip resistors. Table 2-2 shows the microcontroller assignments and how to isolate specific pins.

Important: The quickstart application will not run if one or more jumpers are removed.

Table 2-2. Isolating On-Board Hardware

Microcontroller Pin	EVB Function	To Isolate, Remove...
Pin 26 PA0/U0RX	Virtual COM port receive	JP1
Pin 27 PA1/U0TX	Virtual COM port transmit	JP2
Pin 19 PG0	SD card chip select	JP4
Pin 30 PA4/SSI0RX	SD card data out	JP5
Pin 31 PA5/SSI0TX	SD card and OLED display data in	JP6
Pin 28 PA2/SSI0CLK	SD card and OLED display clock	JP7
Pin 34 PA6/CCP1	OLED display data/control select	JP8
Pin 19 PG0	OLED display chip select	JP9
Pin 18 PG1/PWM1	Sound	JP10
Pin 61 PF1/IDX1	Select switch	JP11

Table 2-2. Isolating On-Board Hardware

Microcontroller Pin	EVB Function	To Isolate, Remove...
Pin 72 PE0/PWM4	Up switch	JP12
Pin 74 PE2/PHB1	Left switch	JP13
Pin 75 PE3/PHA1	Right switch	JP14
Pin 73 PE1/PWM5	Down switch	JP15
Pin 47 PF0/PWM0	User LED	JP16

Interfacing to the EVB

An array of accessible I/O signals makes it easy to interface the EVB to external circuits. All LM3S8962 I/O lines (except those with both JTAG and SWD functions) are brought out to 0.1" pitch pads. For quick reference, silk-screened labels on the PCB show primary pin functions.

Most LM3S8962 I/O signals are +5-V tolerant. Refer to the LM3S8962 microcontroller data sheet for detailed electrical specifications.

Using the In-Circuit Debugger Interface

The Stellaris LM3S8962 Evaluation Kit can operate as an In-Circuit Debugger Interface (ICDI). ICDI acts as a USB to the JTAG/SWD adaptor, allowing debugging of any external target board that uses a Stellaris microcontroller. See "Debugging Modes" on page 16 for a description of how to enter Debug Out mode.

Figure 2-1. ICD Interface Mode

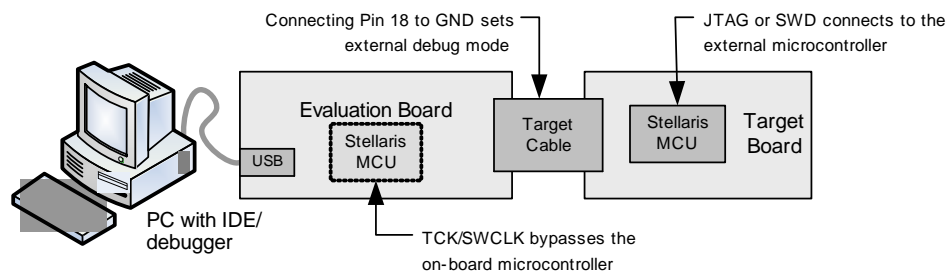

The debug interface operates in either serial-wire debug (SWD) or full JTAG mode, depending on the configuration in the debugger IDE.

The IDE/debugger does not distinguish between the on-EVB Stellaris microcontroller and an external Stellaris microcontroller. The only requirement is that the correct Stellaris device is selected in the project configuration.

CAN Device Board Hardware Description

The CAN device board uses a Stellaris LM3S2110 microcontroller to demonstrate a complete two-node network. The board can be used with the main LM3S8962 evaluation board or as a standalone board.

Device Overview

The Stellaris LM3S2110 ARM Cortex-M3-based microcontroller has 64-KB Flash memory, 25-MHz operation, a CAN module, and a wide range of peripherals. For complete device details, see the LM3S2110 data sheet (order number DS-LM3S2110).

The LM3S2110 microcontroller is factory programmed with a quickstart demonstration program that adds a remote volume control feature to the quickstart application. The quickstart program resides in the LM3S2110 on-chip Flash memory and runs each time power is applied, unless the quickstart has been replaced with a user program.

Power Supply

The CAN device board receives +5.0-V power from the CAN bus and should not be connected to a CAN bus that has a power wire voltage of greater than 10.0 V. If the bus is unpowered, a +5.0-V local power supply must be provided. The LM3S2110 microcontroller is powered from a +3.3-V rail, supplied by a low drop-out (LDO) regulator. +3.3-V power is available for powering external circuits.

Programming and Debugging

A standard 20-pin header supports both JTAG And SWD programming and debugging using either the main LM3S8962 board in ICDI out mode or a full-featured debug interface.

Interfacing

Two push switches and an LED implement a very simple user interface. The board's capabilities are easily expanded using the I/O breakout headers. For breakout header signal assignments, see "LM3S2110 CAN Device Board Connections" on page 33.

Schematics

This section contains the schematics for the LM3S8962 Evaluation Board.

- LM3S8962 Micro, Ethernet, and CAN on page 24
- OLED Display, Switches, and Audio on page 25
- USB, Debugger Interfaces, and Power on page 26
- CAN Device using LM3S2110 on page 27
- JTAG Logic with Auto Mode Detect and Hibernate on page 28

Stellaris LM3S8962 Microcontroller

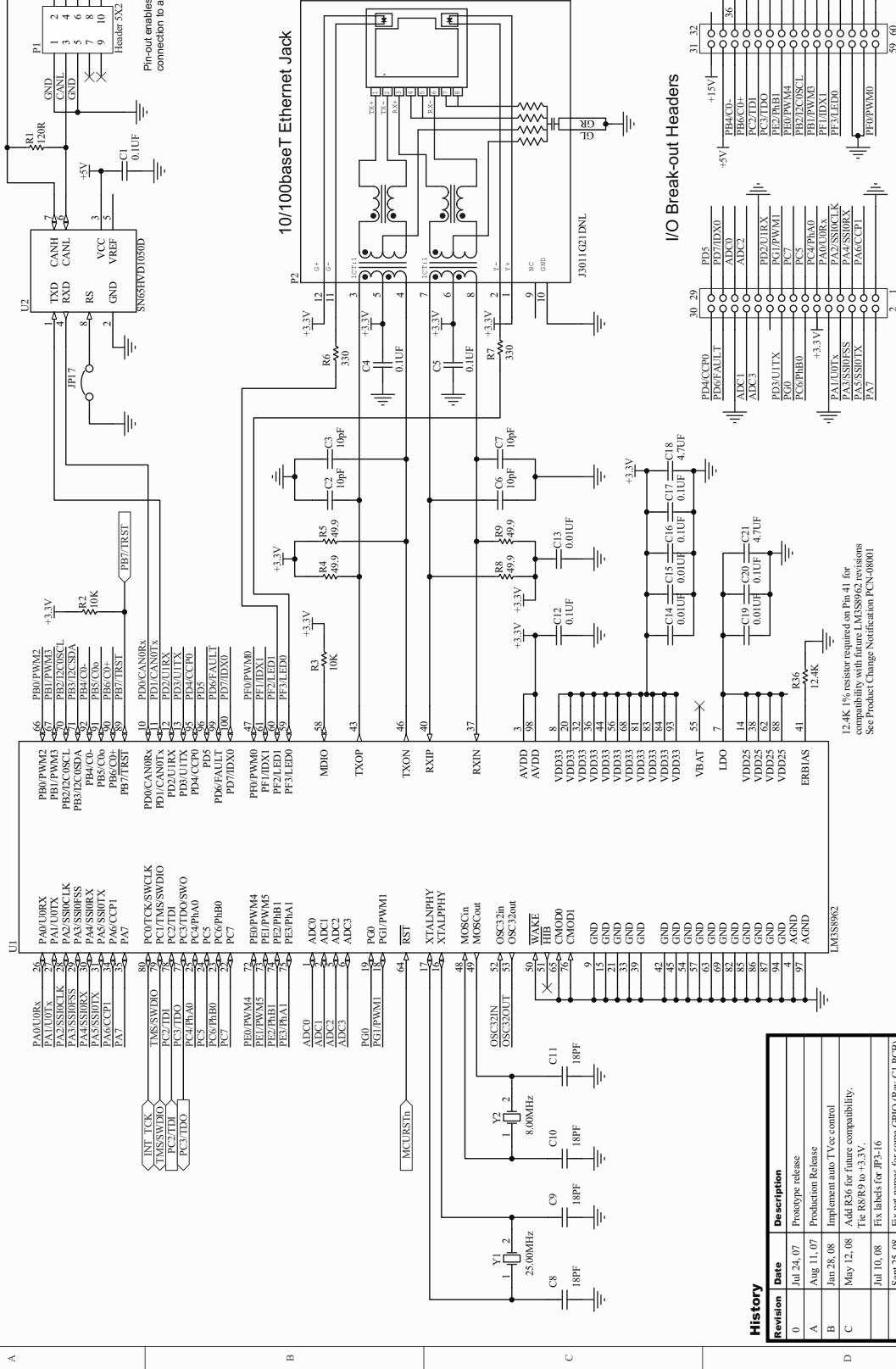

12.4K 1% resistor required on Pin 41 for proper operation with internal clock dividers.
See Product Change Notification PCN-08801

History

Revision	Date	Description
0	Jul 24, 07	Prototype release
A	Aug 11, 07	Production Release
B	Jan 28, 08	Implement auto TVcc control
C	May 12, 08	Add R36 for future compatibility. The R8/R9 to +3.3V.
	Jul 10, 08	Fix labels for #P3-16
	Sept 25, 08	Fix net names for some GPIO (Rev. C1 PCB)

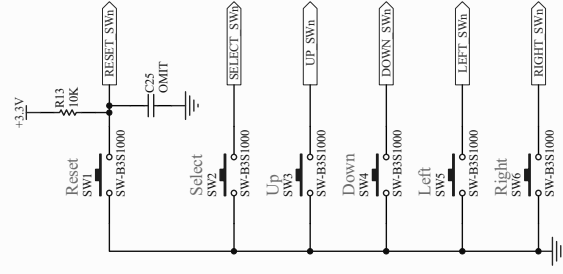

User Switches

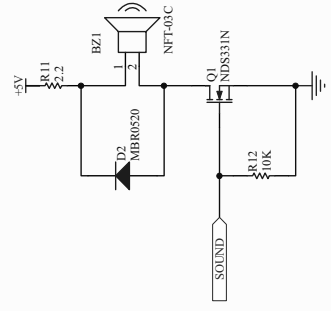

Speaker Circuit

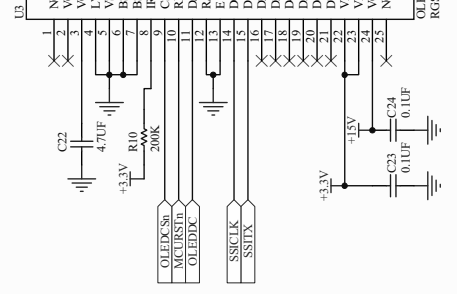

128x96 OLED Graph

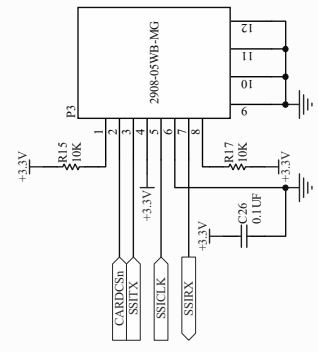

microSD Card Slot

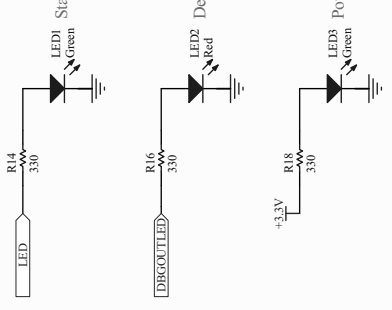

Status LEDs

Power Rail Break-out

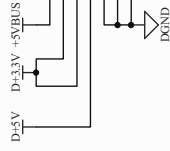

NOTE: Some LM3S2110 pins are not connected. These pins have been brought out on headers to allow Stellaris CAN devices to be used instead of LM3S2110.

Stellaris LM3S2110 Microcontroller

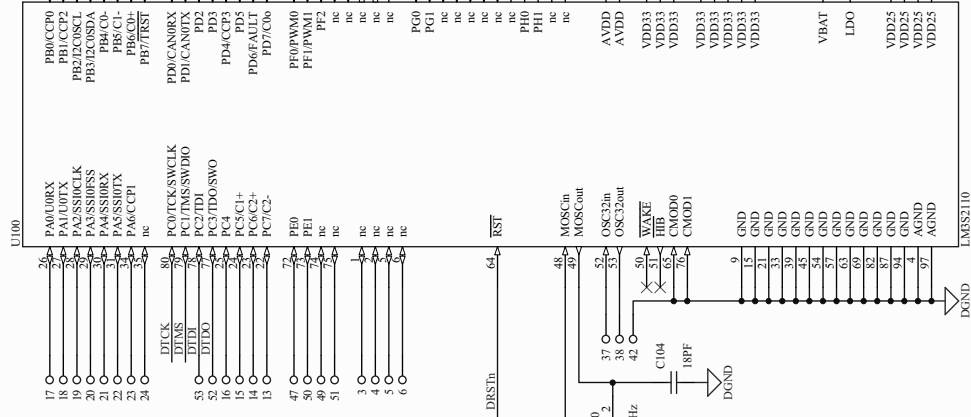

CAN Device Evaluation Board

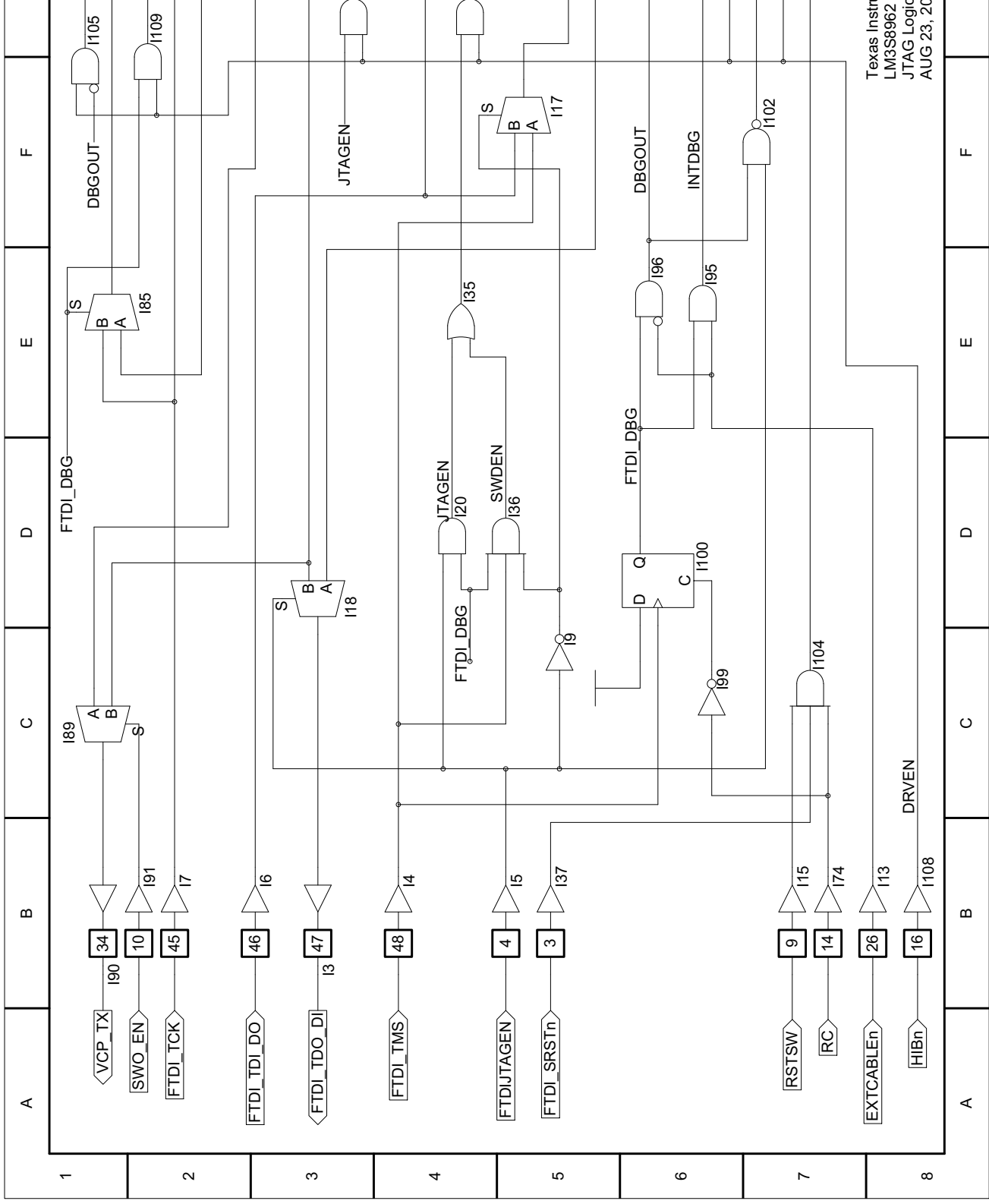

Connection Details

This appendix contains the following sections:

- Component Locations (see page 30)
- Evaluation Board Dimensions (see page 31)
- I/O Breakout Pads (see page 32)
- LM3S2110 CAN Device Board Connections (see page 33)
- Recommended Connectors (see page 33)
- ARM Target Pinout (see page 34)
- References (see page 35)

Component Locations

Figure B-1. LM3S8962 Evaluation Board Component Locations

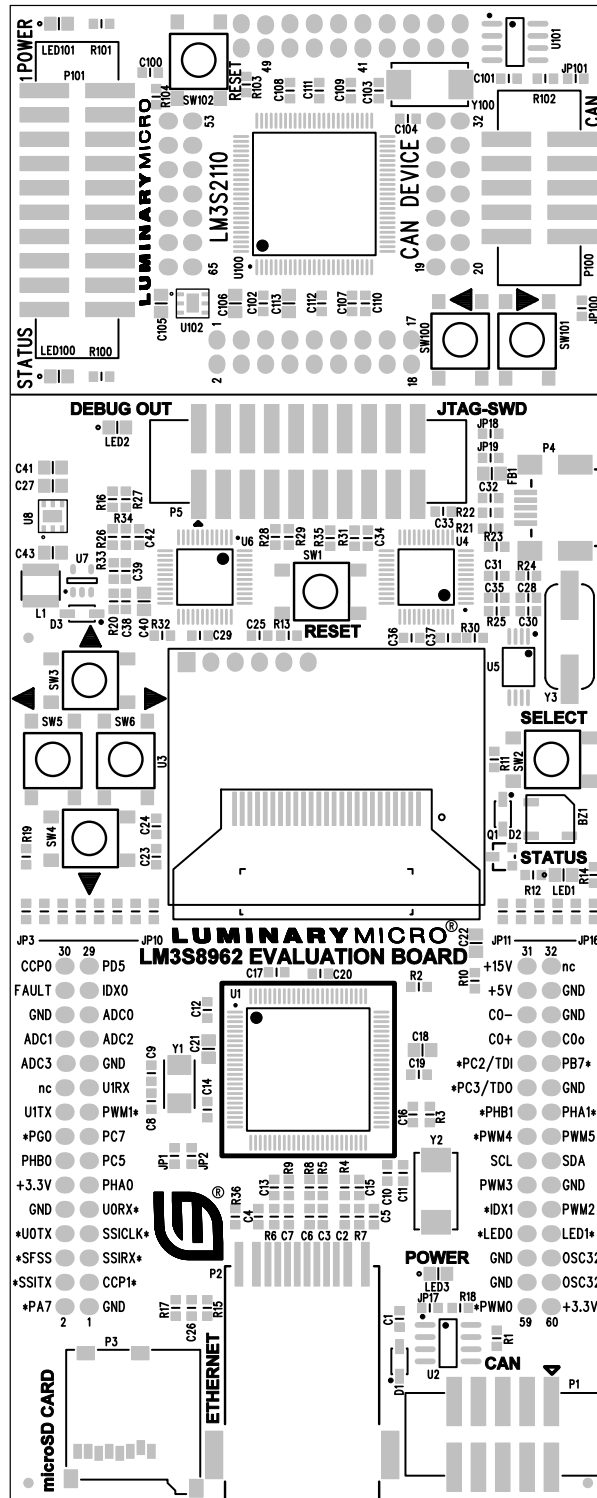

Evaluation Board Dimensions

Figure B-2. LM3S8962 Evaluation Board Dimensions

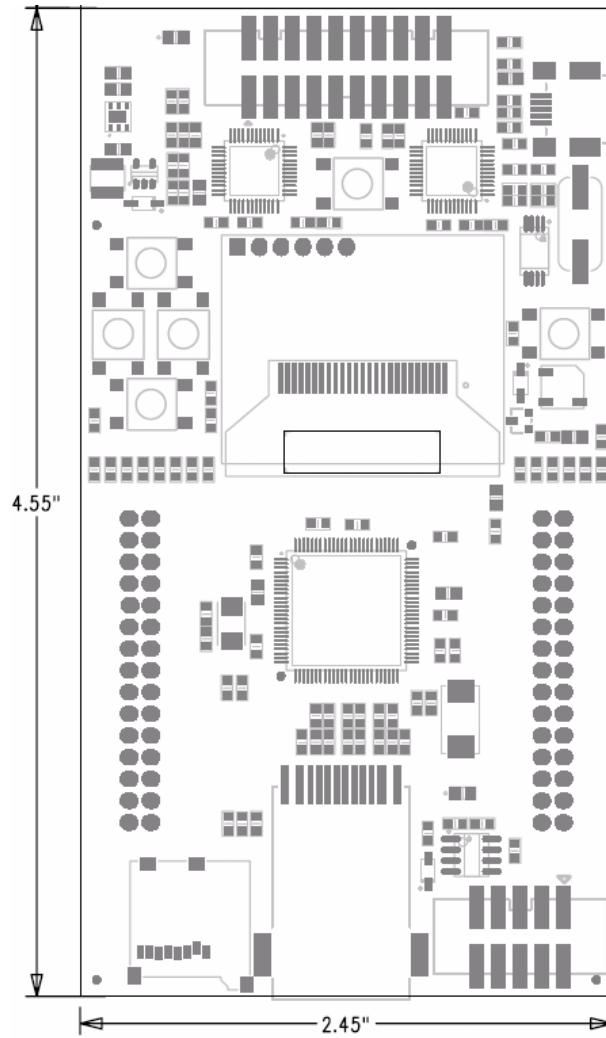
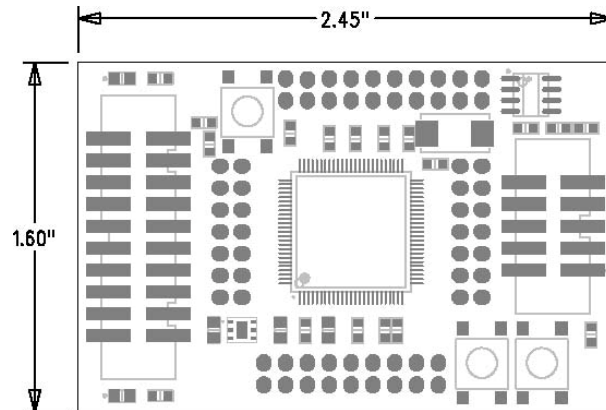

Figure B-3. LM3S2110 CAN Device Board Dimensions



I/O Breakout Pads

The LM3S8962 EVB has 42 I/O pads, 14 power pads, 2 crystal connections, and 2 no-connects, for a total of 60 pads. Connection can be made by soldering wires directly to these pads, or by using 0.1" pitch headers and sockets.

Note: In Table B-2, an asterisk (*) by a signal name (also on the EVB PCB) indicates the signal is normally used for on-board functions. Normally, you should cut the associated jumper (JP1-15) before using an assigned signal for external interfacing.

Table B-1. I/O Breakout Pads

Description	Pad No.	Description	Pad No.	Description	Pad No.
GND	1	GND	21	PC3/TDO	41
PA7*	2	ADC3	22	GND	42
PA6/CCP1*	3	ADC2	23	PE2/PhB1*	43
PA5/SSI0TX*	4	ADC1	24	PE3/PhA1*	44
PA4/SSI0RX*	5	ADC0	25	PE0/PWM4*	45
PA3/SSI0FSS*	6	GND	26	PE1/PWM5*	46
PA2/SSI0CLK*	7	PD7/IDX0	27	PB2/I2C0SCL	47
PA1/U0TX*	8	PD6/FAULT	28	PB3/I2C0SDA	48
PA0/U0RX*	9	PD5	29	PB1/PWM3	49
GND	10	PD4/CCP0	30	GND	50
PC4/PHA0	11	+15V	31	PF1/IDX1*	51
+3.3V	12	No connect	32	PB0/PWM2	52
PC5	13	+5V	33	PF3/LED0*	53
PC6/PHB0	14	GND	34	PF2/LED1*	54
PC7	15	PB4/C0-	35	GND	55
PG0*	16	GND	36	OSC32OUT	56
PG1/PWM1*	17	PB6/C0+	37	GND	57
PD3/U1TX	18	PB5/C00	38	OSC32IN	58
PD2/U1RX	19	PC2/TDI	39	PF0/PWM0*	59
No connect	20	PB7/TRST	40	+3.3V	60

LM3S2110 CAN Device Board Connections

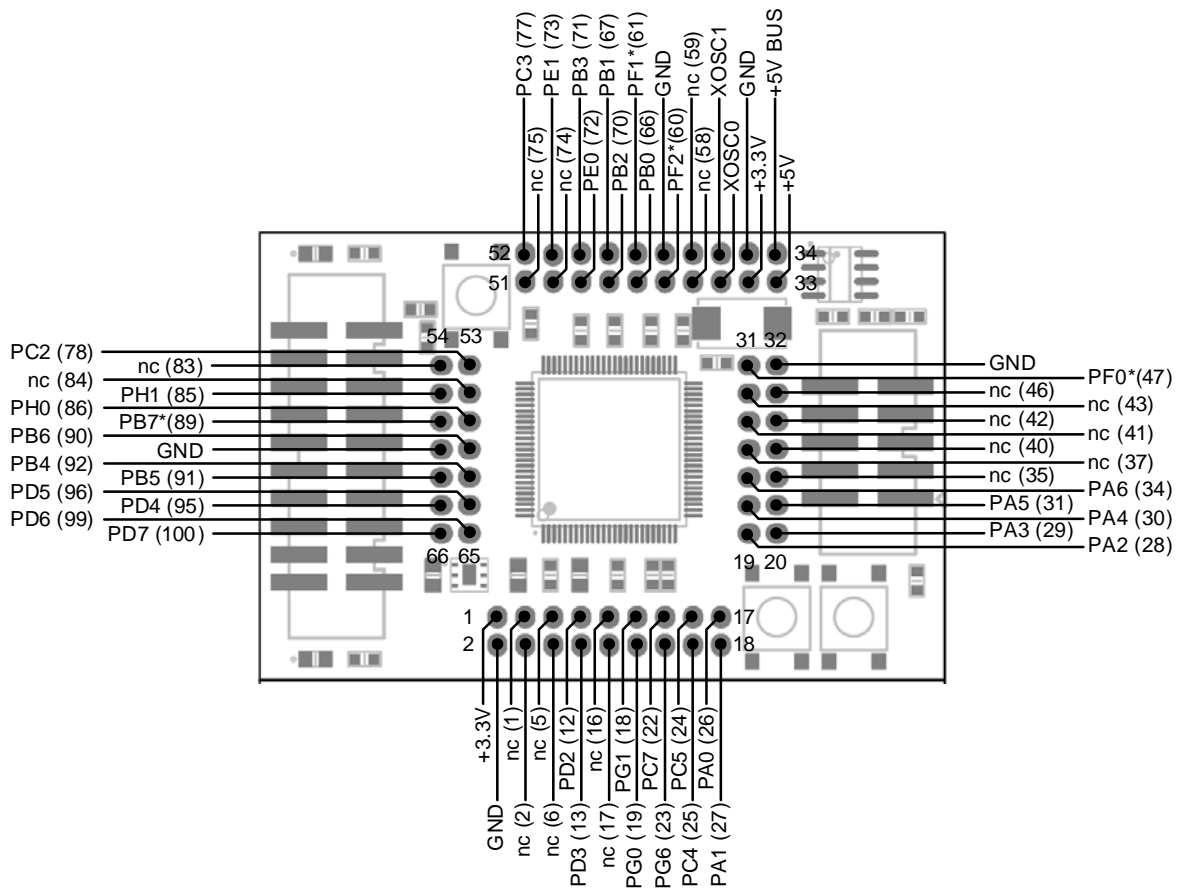

Recommended Connectors

Connection can be made by soldering wires directly to pads or using 0.1" pitch headers and sockets.

Table B-2. Recommended Connectors

Pins 1-30, 31-60 (2 x 15 way)	PCB Socket	Sullins PPPC152LFBN-RC	Digikey S7118-ND
	Cable Socket	3M 89130-0101	Digikey MKC30A-ND
	Pin Header	Sullins PEC15DAAN	Digikey S2011E-15-ND

ARM Target Pinout

In ICDI input and output mode, the Stellaris LM3S8962 Evaluation Kit supports ARM's standard 20-pin JTAG/SWD configuration. The same pin configuration can be used for debugging over serial-wire debug (SWD) and JTAG interfaces. The debugger software, running on the PC, determines which interface protocol is used.

The Stellaris target board should have a 2x10 0.1" pin header with signals as indicated in Table B-3. This applies to both an external Stellaris microcontroller target (Debug Output mode) and to external JTAG/SWD debuggers (Debug Input mode).

Table B-3. 20-Pin JTAG/SWD Configuration

Function	Pin	Pin	Function
VCC (optional)	1	2	nc
nc	3	4	GND
TDI	5	6	GND
TMS	7	8	GND
TCK	9	10	GND
nc	11	12	GND
TDO	13	14	GND
nc	15	16	GND
nc	17	18	GND
nc	19	20	GND

ICDI does not control \overline{RST} (device reset) or \overline{TRST} (test reset) signals. Both reset functions are implemented as commands over JTAG/SWD, so these signals are not necessary.

It is recommended that connections be made to all GND pins; however, both targets and external debug interfaces must connect pin 18 and at least one other GND pin to GND.

References

In addition to this document, the following references are included on the Stellaris LM3S8962 Evaluation Kit CD-ROM and are also available for download at www.ti.com/stellaris:

- *Stellaris LM3S8962 Evaluation Kit Quickstart Guide* for appropriate tool kit (see “Evaluation Kit Contents,” on page 12)
- *Stellaris LM3S8962 Evaluation Kit Read Me First*
- StellarisWare® Driver Library
- *StellarisWare® Driver Library User’s Manual*, publication SW-DRL-UG
- *Stellaris LM3S8962 Data Sheet*, publication DS-LM3S8962
- *Stellaris LM3S2110 Data Sheet*, publication DS-LM3S2110

Additional references include:

- *RiT Display Corporation RGS13128096WH000 OLED Display Data Sheet*
- *Future Technology Devices Incorporated FT2232D Data Sheet*
- Information on development tool being used:
 - RealView MDK web site, www.keil.com/arm/rvmdkkit.asp
 - IAR Embedded Workbench web site, www.iar.com
 - Code Sourcery GCC development tools web site, www.codesourcery.com/gnu_toolchains/arm
 - Code Red Technologies development tools web site, www.code-red-tech.com
 - Texas Instruments’ Code Composer Studio™ IDE web site, www.ti.com/ccs

IMPORTANT NOTICE

Texas Instruments Incorporated and its subsidiaries (TI) reserve the right to make corrections, modifications, enhancements, improvements, and other changes to its products and services at any time and to discontinue any product or service without notice. Customers should obtain the latest relevant information before placing orders and should verify that such information is current and complete. All products are sold subject to TI's terms and conditions of sale supplied at the time of order acknowledgment.

TI warrants performance of its hardware products to the specifications applicable at the time of sale in accordance with TI's standard warranty. Testing and other quality control techniques are used to the extent TI deems necessary to support this warranty. Except where mandated by government requirements, testing of all parameters of each product is not necessarily performed.

TI assumes no liability for applications assistance or customer product design. Customers are responsible for their products and applications using TI components. To minimize the risks associated with customer products and applications, customers should provide adequate design and operating safeguards.

TI does not warrant or represent that any license, either express or implied, is granted under any TI patent right, copyright, mask work right, or other TI intellectual property right relating to any combination, machine, or process in which TI products or services are used. Information published by TI regarding third-party products or services does not constitute a license from TI to use such products or services or a warranty or endorsement thereof. Use of such information may require a license from a third party under the patents or other intellectual property of the third party, or a license from TI under the patents or other intellectual property of TI.

Reproduction of TI information in TI data books or data sheets is permissible only if reproduction is without alteration and is accompanied by all associated warranties, conditions, limitations, and notices. Reproduction of this information with alteration is an unfair and deceptive business practice. TI is not responsible or liable for such altered documentation. Information of third parties may be subject to additional restrictions.

Resale of TI products or services with statements different from or beyond the parameters stated by TI for that product or service voids all express and any implied warranties for the associated TI product or service and is an unfair and deceptive business practice. TI is not responsible or liable for any such statements.

TI products are not authorized for use in safety-critical applications (such as life support) where a failure of the TI product would reasonably be expected to cause severe personal injury or death, unless officers of the parties have executed an agreement specifically governing such use. Buyers represent that they have all necessary expertise in the safety and regulatory ramifications of their applications, and acknowledge and agree that they are solely responsible for all legal, regulatory and safety-related requirements concerning their products and any use of TI products in such safety-critical applications, notwithstanding any applications-related information or support that may be provided by TI. Further, Buyers must fully indemnify TI and its representatives against any damages arising out of the use of TI products in such safety-critical applications.

TI products are neither designed nor intended for use in military/aerospace applications or environments unless the TI products are specifically designated by TI as military-grade or "enhanced plastic." Only products designated by TI as military-grade meet military specifications. Buyers acknowledge and agree that any such use of TI products which TI has not designated as military-grade is solely at the Buyer's risk, and that they are solely responsible for compliance with all legal and regulatory requirements in connection with such use.

TI products are neither designed nor intended for use in automotive applications or environments unless the specific TI products are designated by TI as compliant with ISO/TS 16949 requirements. Buyers acknowledge and agree that, if they use any non-designated products in automotive applications, TI will not be responsible for any failure to meet such requirements.

Following are URLs where you can obtain information on other Texas Instruments products and application solutions:

Products		Applications	
Amplifiers	amplifier.ti.com	Audio	www.ti.com/audio
Data Converters	dataconverter.ti.com	Automotive	www.ti.com/automotive
DLP® Products	www.dlp.com	Communications and Telecom	www.ti.com/communications
DSP	dsp.ti.com	Computers and Peripherals	www.ti.com/computers
Clocks and Timers	www.ti.com/clocks	Consumer Electronics	www.ti.com/consumer-apps
Interface	interface.ti.com	Energy	www.ti.com/energy
Logic	logic.ti.com	Industrial	www.ti.com/industrial
Power Mgmt	power.ti.com	Medical	www.ti.com/medical
Microcontrollers	microcontroller.ti.com	Security	www.ti.com/security
RFID	www.ti-rfid.com	Space, Avionics & Defense	www.ti.com/space-avionics-defense
RF/IF and ZigBee® Solutions	www.ti.com/lprf	Video and Imaging	www.ti.com/video
		Wireless	www.ti.com/wireless-apps

Looking for pricing, stock, or lifecycle information?

Click below to explore more details on WIN SOURCE:

 [View EKK-LM3S8962](#) on WIN SOURCE

 [Texas Instruments](#) Information

Optimize Your Supply Chain with WIN SOURCE Solutions

-  Global Sourcing Solution
-  Obsolete Management
-  Cost Control Management
-  Shortage Management
-  Alternative Solution
-  Excess Inventory Management