



**THE DATASHEET OF  
LM399H#PBF**



### FEATURES

- Compliant with ITU G.703 Pulse Mask Template for 2.048Mbps (E1) Rates
- Seven Independent CEPT Transceivers
- Supports Differential Transformer Coupled Receivers and Transmitters
- On Chip Pulse Shaping for Both 75Ω and 120Ω Line Drivers
- Compliant with ITU G.775 LOS Declaration/Clearing Recommendation
- Optional User Selectable LOS Declaration/Clearing Delay
- Compliant with ITU-T G.823 Jitter Tolerance Requirements
- Logical Inputs Accept either 3.3V or 5.0V Levels
- Ultra-Low Power Dissipation
- +3.3V Supply Operation
- Individual Transmit Channel Over Temperature Protection

### APPLICATIONS

- SDH Multiplexer
- Digital Cross Connects

### GENERAL DESCRIPTION

The XRT5897 is an optimized seven channel 3.3V line interface unit fabricated using low power CMOS technology. The device contains seven independent E1 channels. It is primarily targeted toward SDH multiplexers that accommodate TU12 Tributary Unit Frames. Line cards in these units multiplex 21 E1 interfaces into higher SDH rates. Devices with seven E1 interfaces such as the XRT5897 provide the most efficient method of implementing 21 channel line cards. Each channel performs the driver and receiver functions necessary to convert bipolar signals to logical levels and vice versa. The device requires transformers on both receiver and transmitter sides, and supports both balanced and unbalanced interfaces.

The device offers two distinct modes of LOS detection. The first method, which does not require an external clock, provides an LOS output indication signal with thresholds and delay that comply with the ITU G.775 requirements. In the second mode, the user provides an external clock that increases the delay for LOS declaration and clearing. This feature provides the user with the flexibility to implement LOS specifications that require a delay greater than the G.775 requirements.

### ORDERING INFORMATION

Part No.	Package	Operating Temperature Range
XRT5897IV	100 Lead TQFP (14 x 14 x 1.4mm)	-40°C to +75°C

## BLOCK DIAGRAM

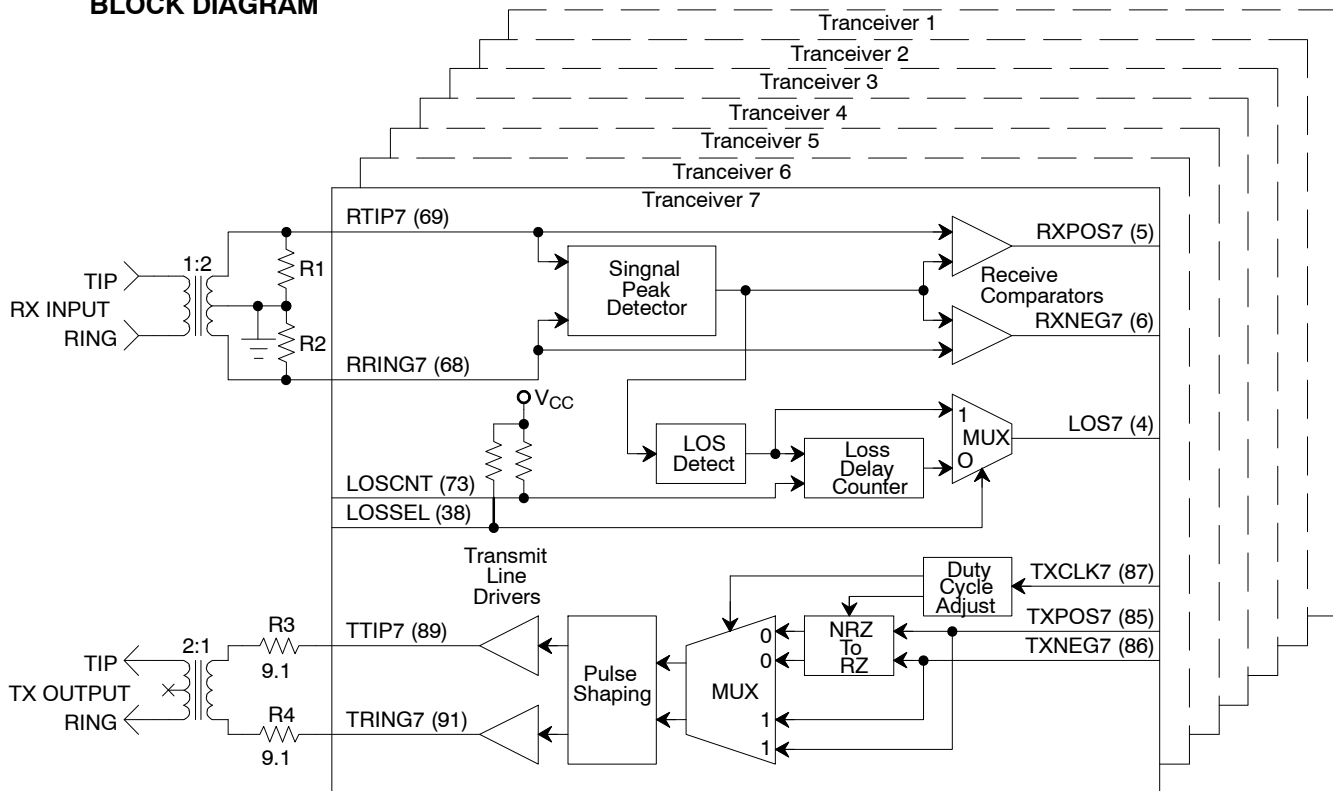

Figure 1. XRT5897 Block Diagram

### Receiver Notes

- The same type 1:2CT ratio transformer may be used at the receiver input and transmitter output.
- R1 and R2 are both 150Ω for 75Ω operation, or 240Ω for 120Ω operation.
- Return loss exceeds ITU G.703 specification with these resistors and a 1:2CT ratio input transformer.

### LOS (Loss of Signal) Notes

- LOSSEL (pin 38) is connected to logic “1” for ITU G.775 compliant LOS delay, or to logic 0 for user programmable additional delay.

- LOSCNT (pin 73) is unconnected when LOSSEL is logic 1, or connected to an external clock when LOSSEL is logic 0.

### Transmitter Notes

- Return loss exceeds ETSI 300 166 specification with a 1:2 ratio transformer.
- R3 and R4 are always 9.1Ω for both 75Ω and 120Ω applications.
- An approach exists that permits the user to operate the XRT5897 with a 5V power supply. For more information, please see application note TAN-12.

**PIN CONFIGURATION**

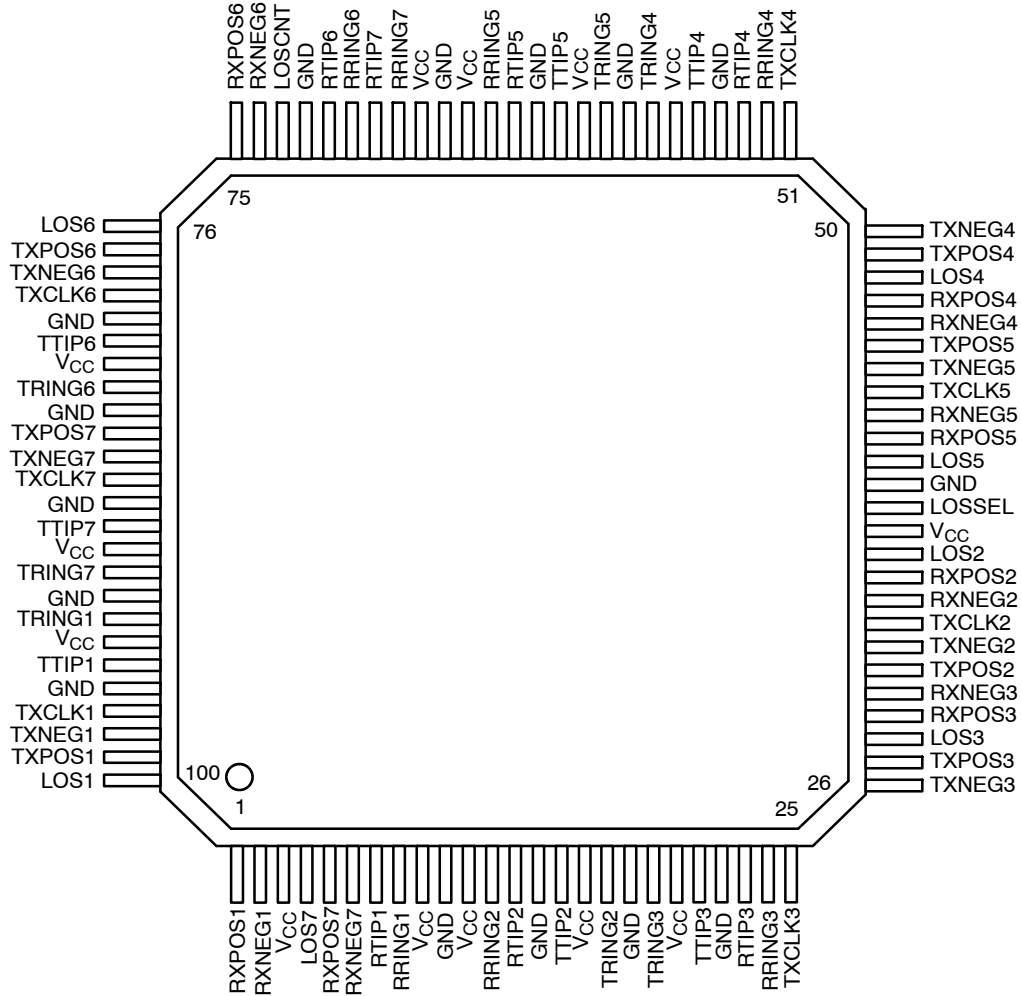

**100 LEAD THIN QUAD FLAT PACK**  
**(14 x 14 x 1.4 mm, TQFP)**

## PIN DESCRIPTION

Pin #	Symbol	Type	Description
1	RXPOS1	O	<b>Receiver 1 Positive Data Out.</b> Positive RZ data output for channel 1.
2	RXNEG1	O	<b>Receiver 1 Negative Data Out.</b> Negative RZ data output for channel 1.
3	V <sub>CC</sub>		<b>Positive Supply (+3.3V ± 5%).</b> Digital circuitry.
4	LOS7	O	<b>Receiver 7 Loss of Signal.</b> Asserted during LOS condition.
5	RXPOS7	O	<b>Receiver 7 positive Data Out.</b> Positive RZ data output for channel 7.
6	RXNEG7	O	<b>Receiver 7 Negative Data Out.</b> Negative RZ data output for channel 7.
7	RTIP1	I	<b>Receiver 1 Positive Bipolar Input.</b>
8	RRING1	I	<b>Receiver 1 Negative Bipolar Input.</b>
9	V <sub>CC</sub>		<b>Positive Supply (+3.3V ± 5%).</b> Analog circuitry.
10	GND		<b>Analog Ground.</b>
11	V <sub>CC</sub>		<b>Positive Supply (+3.3V ± 5%).</b> Receivers 1, 2, 3, and 7.
12	RRING2	I	<b>Receiver 2 Negative Bipolar Input.</b>
13	RTIP2	I	<b>Receiver 2 Positive Bipolar Input.</b>
14	GND		<b>Analog Ground.</b> Receivers 1, 2, 3, and 7.
15	TTIP2	O	<b>Transmitter 2 Positive Bipolar Output.</b>
16	V <sub>CC</sub>		<b>Positive Supply (+3.3V ± 5%).</b> Transmitter channel 2.
17	TRING2	O	<b>Transmitter 2 Negative Bipolar Output.</b>
18	GND		<b>Digital Ground.</b> Transmitter channel 2.
19	TRING3	O	<b>Transmitter 3 Negative Bipolar Output.</b>
20	V <sub>CC</sub>		<b>Positive Supply (+3.3V ± 5%).</b> Transmitter channel 3.
21	TTIP3	O	<b>Transmitter 3 Positive Bipolar Output.</b>
22	GND		<b>Digital Ground.</b> Transmitter channel 3.
23	RTIP3	I	<b>Receiver 3 Positive Bipolar Input.</b>
24	RRING3	I	<b>Receiver 3 Negative Bipolar Input.</b>
25	TXCLK3	I	<b>Transmitter 3 Clock Input.</b> Use for clocked mode with NRZ data. <sup>1</sup>
26	TXNEG3	I	<b>Transmitter 3 Negative Data Input.</b> Negative NRZ or RZ data input. <sup>1</sup>
27	TXPOS3	I	<b>Transmitter 3 Positive Data Input.</b> Positive NRZ or RZ data input. <sup>1</sup>
28	LOS3	O	<b>Receiver 3 Loss of Signal.</b> Asserted during LOS condition.
29	RXPOS3	O	<b>Receiver 3 Positive Data Out.</b> Positive RZ data output for channel 3.
30	RXNEG3	O	<b>Receiver 3 Negative Data Out.</b> Negative RZ data output for channel 3.
31	TXPOS2	I	<b>Transmitter 2 Positive Data Input.</b> Positive NRZ or RZ data input. <sup>1</sup>
32	TXNEG2	I	<b>Transmitter 2 Negative Data Input.</b> Negative NRZ or RZ data input. <sup>1</sup>
33	TXCLK2	I	<b>Transmitter 2 Clock Input.</b> Use for clocked mode with NRZ data. <sup>1</sup>
34	RXNEG2	O	<b>Receiver 2 Negative Data Out.</b> Negative RZ data output for channel 2.
35	RXPOS2	O	<b>Receiver 2 Positive Data Out.</b> Positive RZ data output for channel 2.

**Note:**

<sup>1</sup> Has internal pull-up 50KΩ resistor.

## PIN DESCRIPTION (CONT'D)

Pin #	Symbol	Type	Description
36	LOS2	O	<b>Receiver 2 Loss of Signal.</b> Asserted during LOS condition.
37	V <sub>CC</sub>		<b>Digital Supply (+3.3V ± 5%).</b> Digital circuitry.
38	LOSSEL	I	<b>Loss of Signal Delay Select.</b> “Hi” selects G.775, “Lo” selects user programmable. <sup>1</sup>
39	GND		<b>Digital Ground.</b>
40	LOS5	O	<b>Receiver 5 Loss of Signal.</b> Asserted during LOS condition.
41	RXPOS5	O	<b>Receiver 5 Positive Data Out.</b> Positive RZ data output for channel 5.
42	RXNEG5	O	<b>Receiver 5 Negative Data Out.</b> Negative RZ data output for channel 5.
43	TXCLK5	I	<b>Transmitter 5 Clock Input.</b> Use for clocked mode with NRZ data. <sup>1</sup>
44	TXNEG5	I	<b>Transmitter 5 Negative Data Input.</b> Negative NRZ or RZ data input. <sup>1</sup>
45	TXPOS5	I	<b>Transmitter 5 Positive Data Input.</b> Positive NRZ or RZ data input. <sup>1</sup>
46	RXNEG4	O	<b>Receiver 4 Negative Data Out.</b> Negative RZ data output for channel 4.
47	RXPOS4	O	<b>Receiver 4 Positive Data Out.</b> Positive RZ data output for channel 4.
48	LOS4	O	<b>Receiver 4 Loss of Signal.</b> Asserted during LOS condition.
49	TXPOS4	I	<b>Transmitter 4 Positive Data Input.</b> Positive NRZ or RZ data input. <sup>1</sup>
50	TXNEG4	I	<b>Transmitter 4 Negative Data Input.</b> Negative NRZ or RZ data input. <sup>1</sup>
51	TXCLK4	I	<b>Transmitter 4 Clock Input.</b> Use for clocked mode with NRZ data. <sup>1</sup>
52	RRING4	I	<b>Receiver 4 Negative Bipolar Input.</b>
53	RTIP4	I	<b>Receiver 4 Positive Bipolar Input.</b>
54	GND		<b>Analog Ground.</b>
55	TTIP4	O	<b>Transmitter 4 Positive Bipolar Output.</b>
56	V <sub>CC</sub>		<b>Positive Supply (+3.3V ± 5%).</b> Transmitter channel 4.
57	TRING4	O	<b>Transmitter 4 Negative Bipolar Output.</b>
58	GND		<b>Digital Ground.</b> Transmitter channel 4.
59	TRING5	O	<b>Transmitter 5 Negative Bipolar Output.</b>
60	V <sub>CC</sub>		<b>Positive Supply (+3.3V ± 5%).</b> Transmitter channel 5.
61	TTIP5	O	<b>Transmitter 5 Positive Bipolar Output.</b>
62	GND		<b>Digital Ground.</b> Transmitter channel 5.
63	RTIP5	I	<b>Receiver 5 Positive Bipolar Input.</b>
64	RRING5	I	<b>Receiver 5 Negative Bipolar Input.</b>
65	V <sub>CC</sub>		<b>Positive Supply (+3.3V ± 5%).</b> Low level transmitter analog circuitry.
66	GND		<b>Analog Ground.</b> Low level transmitter analog circuitry.
67	V <sub>CC</sub>		<b>Positive Supply (+3.3V ± 5%).</b> Receiver channels 4, 5, and 6.
68	RRING7	I	<b>Receiver 7 Negative Bipolar Input.</b>
69	RTIP7	I	<b>Receiver 7 Positive Bipolar Input.</b>
70	RRING6	I	<b>Receiver 6 Negative Bipolar Input.</b>

**Note:**

<sup>1</sup> Has internal pull-up 50KΩ resistor.

## PIN DESCRIPTION (CONT'D)

Pin #	Symbol	Type	Description
71	RTIP6	I	<b>Receiver 6 Positive Bipolar Input.</b>
72	GND		<b>Analog Ground.</b> Receiver channels 4, 5, and 6.
73	LOSCNT	I	<b>Loss of Signal Timing Clock Input.</b> For user-programmable LOS delay. <sup>1</sup>
74	RXNEG6	O	<b>Receiver 6 Negative Data Out.</b> Negative RZ data output for channel 6.
75	RXPOS6	O	<b>Receiver 6 Positive Data Out.</b> Positive RZ data output for channel 6.
76	LOS6	O	<b>Receiver 6 Loss of Signal.</b> Asserted during LOS condition.
77	TXPOS6	I	<b>Transmitter 6 Positive Data Input.</b> Positive NRZ or RZ data input. <sup>1</sup>
78	TXNEG6	I	<b>Transmitter 6 Negative Data Input.</b> Negative NRZ or RZ data input. <sup>1</sup>
79	TXCLK6	I	<b>Transmitter 6 Clock Input.</b> Use for clocked mode with NRZ data. <sup>1</sup>
80	GND		<b>Digital Ground.</b> Transmitter channel 6.
81	TTIP6	O	<b>Transmitter 6 Positive Bipolar Output.</b>
82	V <sub>CC</sub>		<b>Positive Supply (+3.3V ± 5%).</b> Transmitter channel 6.
83	TRING6	O	<b>Transmitter 6 Negative Bipolar Output.</b>
84	GND		<b>Digital Ground.</b>
85	TXPOS7	I	<b>Transmitter 7 Positive Data Input.</b> Positive NRZ or RZ data input. <sup>1</sup>
86	TXNEG7	I	<b>Transmitter 7 Negative Data Input.</b> Negative NRZ or RZ data input. <sup>1</sup>
87	TXCLK7	I	<b>Transmitter 7 Clock Input.</b> Use for clocked mode with NRZ data. <sup>1</sup>
88	GND		<b>Analog Ground.</b>
89	TTIP7	O	<b>Transmitter 7 Positive Bipolar Output.</b>
90	V <sub>CC</sub>		<b>Positive Supply (+3.3V ± 5%).</b> Transmitter channel 7.
91	TRING7	O	<b>Transmitter 7 Negative Bipolar Output.</b>
92	GND		<b>Digital Ground.</b> Transmitter channel 7.
93	TRING1	O	<b>Transmitter 1 Negative Bipolar Output.</b>
94	V <sub>CC</sub>		<b>Positive Supply (+3.3V ± 5%).</b> Transmitter channel 1.
95	TTIP1	O	<b>Transmitter 1 Positive Bipolar Output.</b>
96	GND		<b>Digital Ground.</b> Transmitter channel 1.
97	TXCLK1	I	<b>Transmitter 1 Clock Input.</b> Use for clocked mode with NRZ data. <sup>1</sup>
98	TXNEG1	I	<b>Transmitter 1 Negative Data Input.</b> Negative NRZ or RZ data input. <sup>1</sup>
99	TXPOS1	I	<b>Transmitter 1 Positive Data Input.</b> Positive NRZ or RZ data input. <sup>1</sup>
100	LOS1	O	<b>Receiver 1 Loss of Signal.</b> Asserted during LOS condition.

**Note:**

<sup>1</sup> Has internal pull-up 50KΩ resistor.

## ELECTRICAL CHARACTERISTICS

Test Conditions:  $V_{CC} = 3.3V \pm 5\%$ ,  $T_A = -40$  to  $25$  to  $75^\circ C$ , Unless Otherwise Specified

Symbol	Parameter	Min.	Typ.	Max.	Unit	Conditions
<b>DC Electrical Characteristics</b>						
<b>Parameters</b>						
$V_{CC}$	Voltage Supply	3.135	3.3	3.465	V	3.3V operation
<b>Inputs</b>						
$V_{IH}$	Input High Level	2.0		5.0	V	
$V_{IL}$	Input Low Level			0.8	V	
<b>Outputs</b>						
$V_{OH}$	Output High Level	2.4			V	$I_{OH} = -4mA$
$V_{OL}$	Output Low Level			0.4	V	$I_{OL} = 4mA$
<b>Receiver Specifications</b>						
$RX_{CL}$	Allowable Cable Loss	0		12	dB	Cable loss at 1.024MHz (Relative to 0dB = 2.37Vp measured from RTIP or RRING to ground).
$RX_{IM}$	Interference Margin	-15	-12		dB	With 6dB cable loss
$RX_{XI}$	Receiver Slicing Threshold	<b>45</b>	50	<b>55</b>	%	% of peak input voltage at -3dB cable loss
$RX_{LOSSET}$	LOS Must Be Set If RX Sig. Atten. $\geq 32dB$ (For Any Valid Data Pattern)		15		dB	Relative to 0dB = 2.37Vp Measured from RTIP or RRING to ground.
$RX_{LOSCLR}$	LOS Must Be Cleared If RX Sig. Atten. $< 9dB$		13		dB	Relative to 0dB = 2.37Vp measured from RTIP or RRING to ground.
$RX_{LOSHYST}$	Hysteresis on Input Data		2		dB	For LOS output state change
$RX_{IN}$	Input Impedance	5			k $\Omega$	Up to 3.072MHz (Measured from RTIP or RRING to ground).
	Jitter Tolerance:					
	20Hz	10			U <sub>lpp</sub>	
	700Hz	5			U <sub>lpp</sub>	
	10kHz – 100kHz	0.3			U <sub>lpp</sub>	
	Return Loss:					
	51khz – 102kHz	14			dB	Per ITU-T G.703
	102kHz – 2048kHz	20			dB	
	2048kHz – 3072kHz	16			dB	
<b>Power Specifications <math>V_{CC} = 3.3V</math></b>						
$P_D$	Power Dissipation		715	920	mW	All 1's Transmit and Receive 75 $\Omega$
$P_D$	Power Dissipation		117	155	mW	All Drivers Power Down
$P_C$	Power Consumption 75 $\Omega$		1260	1465	mW	All 1's Transmit and Receive
$P_C$	Power Consumption 75 $\Omega$		880	1065	mW	50% data density, Transmit and Receive

$P_C$	Power Consumption 120 $\Omega$		1025	1255	mW	All 1's Transmit and Receive
$P_C$	Power Consumption 120 $\Omega$		745	945	mW	50% data density, Transmit and Receive

**Note:**

***Bold face parameters are covered by production test and guaranteed over operating temperature range.***

## ELECTRICAL CHARACTERISTICS (CONT'D)

Test Conditions:  $V_{CC} = 3.3V \pm 5\%$ ,  $T_A = -40$  to  $25$  to  $75^\circ C$ , Unless Otherwise Specified

Symbol	Parameter	Min.	Typ.	Max.	Unit	Conditions
<b>AC Electrical Characteristics</b>						
$V_{TXOUT}$	Output Pulse Amplitude ( $R_L = 75\Omega$ )	<b>2.13</b>	2.37	<b>2.60</b>	V	Trans. = 1:2 ratio, 9.1 $\Omega$ in series with each end of primary
$V_{TXOUT}$	Output Pulse Amplitude ( $R_L = 120\Omega$ )	2.70	3.0	3.30	V	Trans. = 1:2 ratio, 9.1 $\Omega$ in series with each end of primary
$T_{XPW}$	Output Pulse Width	<b>224</b>	244	<b>264</b>	ns	
$PN_{IMP}$	Pos/Neg Pulse Unbalanced		5		%	
$T_1$	TXCLK Clock Period (E1)		488		ns	
$T_2$	TXCLK Duty Cycle	<b>30</b>	50	<b>70</b>	%	
$T_{SU}$	Data Set-up Time, TDATA to TXCLK	<b>75</b>			ns	50% TXCLK Duty Cycle
$T_{HO}$	Data Hold Time, TDATA to TXCLK	<b>30</b>			ns	50% TXCLK Duty Cycle
$T_R$	TXCLK Rise Time (10% to 90%)		40		ns	
$T_F$	TXCLK Fall Time (10% to 90%)		40		ns	
$T_{3-noclk}$	Data Prop. Delay No-Clock Mode		35	50	ns	
$T_{3-clk}$	Data Prop. Delay Clock Mode		470		ns	50% TXCLK Duty Cycle
$T_4$	Receive Data High	<b>219</b>	244	<b>269</b>	ns	0dB Cable Loss
$T_5$	RX Data Prop. Delay			40	ns	15pF Load
$T_6$	Receive Rise Time			40	ns	15pF Load
$T_7$	Receive Rise Time			40	ns	15pF Load

**Note:**

**Bold face parameters are covered by production test and guaranteed over operating temperature range.**

### ABSOLUTE MAXIMUM RATINGS

Storage Temperature . . . . .  $-65^\circ C$  to  $+150^\circ C$   
 Operating Temperature . . . . .  $-40^\circ C$  to  $+75^\circ C$   
 Supply Voltage . . . . .  $+0.3V$  to  $+6.0V$

## Disabling Output Drivers

Output drivers may be individually disabled (hi-z output) by either of the following methods.

1. Either connect the transmit data inputs TXPOS and TXNEG for the channel to be disabled to a logic 1 source ( $V_{CC}$ ), or allow them to float (inputs have internal pull-up resistors).
2. Connect TXCLK for the channel to be disabled to logic 0 source (Ground), and also apply data to the TXPOS and TXNEG inputs of that channel.

## TRANSFORMER REQUIREMENTS

Turns Ratio	Line Impedance
1:2 CT	75Ω or 120Ω

**Table 1. Input Transformer Requirements**

Turns Ratio	Line Impedance
1:2	75Ω or 120Ω

**Table 2. Output Transformer Requirements**

**Note:**

The same type 1:2 CT ratio device may be used at both receiver input and transmitter output.

The following transformers have been tested with the XRT5897:

HALO type TG26-1205(package contains two 1 CT:2 CT ratio transformers)

Pulse type PE-65535 (1:2 CT ratio)

Transpower Technologies type TTI 7154-R (1:2 CT ratio)

## Magnetic Supplier Information:

HALO Electronics, Inc.  
P.O. Box 5826  
Redwood City, CA 94063  
Tel. (415) 568-5800  
Fax. (415)568-6161

Pulse  
Telecom Product Group  
P.O. Box 12235  
San Diego, CA 92112  
Tel. (619) 674-8100  
Fax. (619) 674-8262

Transpower Technologies, Inc.  
24 Highway 28, Suite 202  
Crystal Bay, NV 89402-0187  
Tel. (702) 831-0140  
Fax. (702) 831-3521

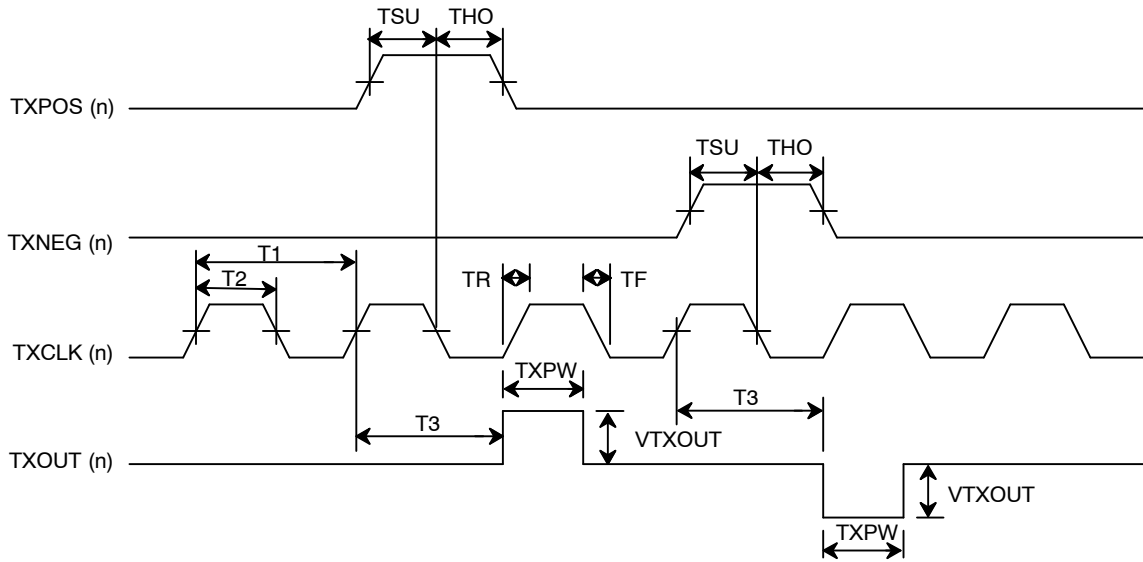

Figure 2. Transmit Timing Diagram

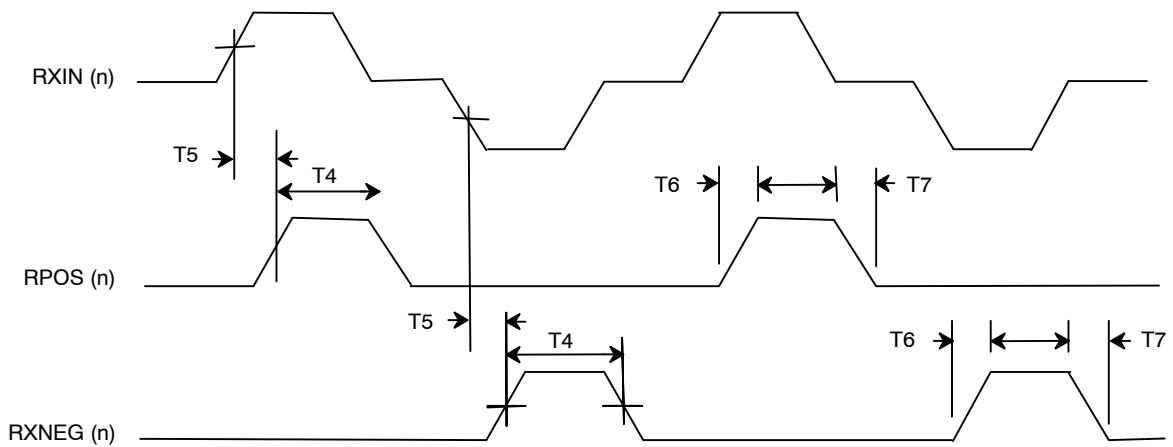

Figure 3. Receive Timing Diagram

## RETURN LOSS SPECIFICATIONS

The following transmitter and receiver return loss specifications are based on a typical 1:2CT ratio transformer.

Frequency Range	75Ω		120Ω		Unit
	Min.	Typ.	Min.	Typ.	
51kHz to 102kHz	16	22	10	15	dB
102kHz to 2.048MHz	16	22	10	15	dB
2.048MHz to 3.072MHz	11	18	10	14	dB

**Table 3. Transmitter Return Loss Specification**

### Transmit Return Loss Notes

- Output transformer ratio is 1:2 (return loss exceeds ETSI 300 166 with this transformer).
- For both 75Ω and 120Ω applications, 9.1Ω, 1% resistors are connected between each end of the transformer primary and the XRT5897 TTIP and TRING pins.

Frequency Range	75Ω		120Ω		Unit
	Min.	Typ.	Min.	Typ.	
51kHz to 102kHz	16	28	15	18	dB
102kHz to 2.048MHz	22	34	22	25	dB
2.048MHz to 3.072MHz	18	26	20	30	dB

**Table 4. Receiver Return Loss Specification**

### Receiver Return Loss Notes

- Input transformer ratio is 1:2 CT.
- Transformer center tap is grounded.
- Each half of transformer secondary is terminated with 150Ω for 75Ω operation, or 240Ω for 120Ω operation (resistors are 1% tolerance).

## SYSTEM DESCRIPTION

This device is a seven channel E1 transceiver that provides an electrical interface for 2.048Mbps applications. Its unique architecture includes seven receiver circuits that convert ITU G.703 compliant bipolar signals to TTL compatible logic levels. Each receiver includes a LOS (Loss of Signal) detection circuit that may be configured for either a fixed or a user-programmable LOS response time delay. Similarly, in the transmit direction, seven transmitters convert TTL compatible logic levels to G.703 compatible bipolar signals. Each transmitter may be operated either with RZ, or NRZ data types. In NRZ mode a transmit clock is required as well. The following description applies to any of the seven receivers or transmitters contained in the XRT5897. Therefore, the suffix numbers for a particular channel are deleted for simplicity. i.e. "RTIP" applies to RTIP1 through RTIP7.

### Receiver Operation

A bipolar signal is transformer-coupled to the receiver differential inputs (RTIP and RRING). The receiver is able to tolerate up to 12dB of line loss measured at 1.024MHz. It contains slicing circuitry that automatically samples the incoming data at a fixed percentage (50% nominal) of the peak signal amplitude. A precision peak detector maintains the slicing level accuracy. The TTL compatible receiver output data rails appear at the RXPOS and RXNEG pins. The pulse width of this data; which is in RZ format, is a function of the amount of the cable loss present.

### Receiver Loss Of Signal Detection (LOS)

Absence of signal at any receiver input is detected by the loss of signal (LOS) circuit. One LOS detection circuitry is provisioned for each receiver. The LOS signal is asserted (LOS=1) when a LOS condition is detected and is cleared (LOS=0) when a valid input signal is restored.

Two modes of LOS circuit operation are supported. These distinct modes are called "automatic" and "user-programmable". When LOSSEL (pin 38) is set to logic "1", the automatic mode is selected. In this mode the LOS condition will be declared and cleared in full

compliance with ITU G.775 specification. When LOSSEL is connected to logic "0", the user-programmable delay mode is enabled. In this mode the user has the option of extending the delay of LOS declaration and clearing specified in the ITU G.775. This is done by providing a user-supplied clock to LOSCNT (pin 73). The "user programmable mode" is provisioned to allow systems designers to comply with older versions of LOS specifications in legacy systems. It needs to be stressed that the delay for declaration and clearing of the LOS condition will never be less than the range specified in the G.775 specification (10-255 pulse intervals).

The LOS detection/clearing circuitry of the XRT5897 in "automatic" mode will detect LOS when the incoming signal has "no transitions," i.e. when the signal level is less than or equal to a signal level  $A_D$  dB below nominal signal level, for  $N$  consecutive pulse intervals, where  $10 \leq N \leq 255$ . The value of  $A_D$  can vary between 10dB to 32dB depending on the ones density of the incoming signal assuming the received data has minimum permissible ones density. Furthermore LOS detect is cleared when the incoming signal has "transitions," i.e. when the signal level is greater than or equal to a signal level of  $A_C$  dB below nominal, for  $N$  consecutive pulse intervals, where  $10 \leq N \leq 255$ . The value of  $A_C$  can vary between 9dB to 31dB depending on the ones density of the incoming signal assuming the received data has minimum permissible ones density. Each pulse interval is 488ns at E1 rates. The absolute value of  $A_C$  is always smaller than  $A_D$  by at least 1dB.

The LOS detection/clearing criteria described above is fully compliant with G.775 LOS specification. In the "user programmable" mode the user has the option of extending the declaration and clearing delay ( $10 \leq N \leq 255$ ) by an amount which is equal to  $2048 \times T$ .  $T$  is the time period of the clock supplied to LOSCNT (pin 73) by the user.

Nominal signal level is defined as 2.37V peak measured between RTIP or RRING and ground. (This voltage will be present in  $75\Omega$  applications using a 1:2 CT ratio input transformer terminated in  $300\Omega$  with the center tap grounded with 0dB of cable and a 2.37V peak amplitude transmit pulse at the cable input.)

## Transmitters

This device contains four identical ITU G.703 compliant transmitters. The output stage of each transmitter is a differential voltage driver. External resistors need to be connected to the primary of output transformer. This is necessary to maintain an accurate source impedance that ensures compliance to ETSI 300 166 return loss requirement.

TTL compatible dual rail transmit data signals are supplied to TXPOS and TXNEG inputs. The transmitter differential outputs TTIP and TRING are connected to the output transformer primary through series 9.1Ω resistors.

All the four transmitters can be operated in two distinct

modes of operation referred to as “clocked” or “clockless” modes. The operational mode is selected automatically based on the signal provided to TXCLK input. If a clock is present at this pin, the transmitter detects its presence and operates in the clocked mode. In this mode, the transmit input should be supplied with full-width NRZ pulses. If a clock is not present at the TXCLK input (pin is left open), the part operates in the clockless mode. In this mode, RZ data should be supplied to the device. Each transmit channel of XRT5897 has a duty cycle correction circuitry. This enables the device to produce output bipolar pulses fully compliant with G.703 despite having TXCLK signal with 30% to 70% duty cycle.

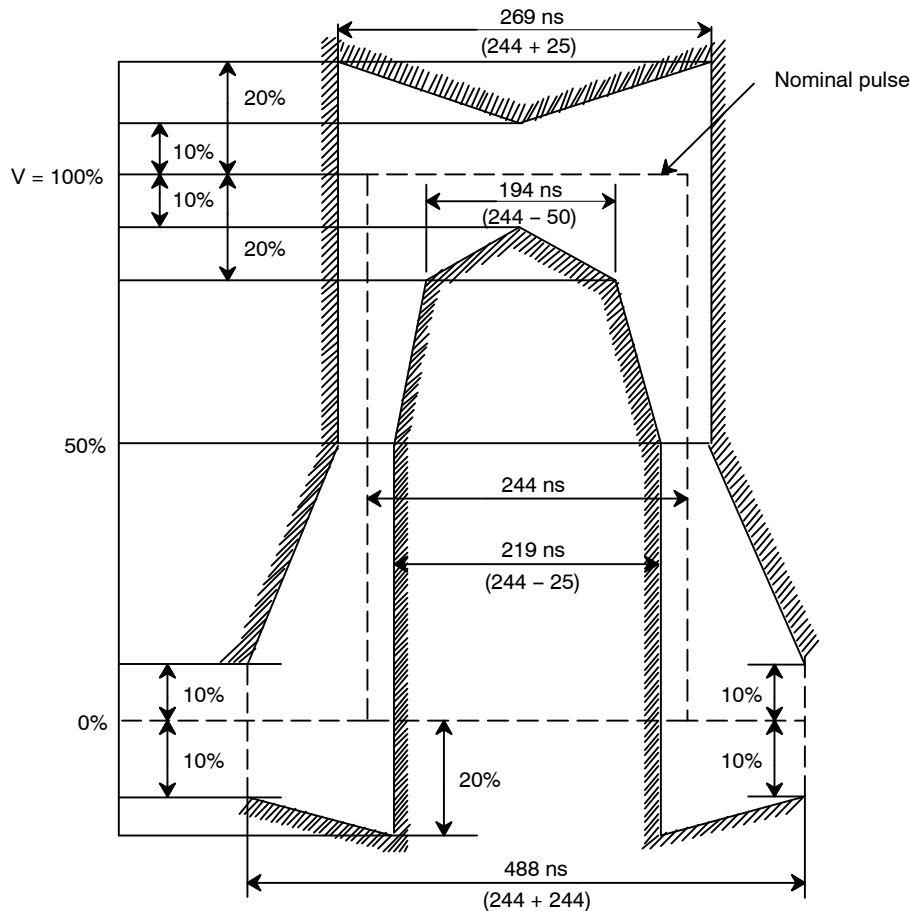

**Note:** V corresponds to the nominal peak value

**Figure 4. CCITT G.703 Pulse Template**

### Transmitter Output Pulse Measurement

Figure 1 shows a typical transmit pulse plotted on the template shown in ITU G.703 Figure 15/G.703. The following conditions apply:

$V_{CC}=3.30V$

Transmitter output transformer secondary terminated with  $120\Omega$ .

All ones signal.

Receiver output looped backed into transmitter digital input.

Operation without transmitter clock (RZ data).

Measurement made with a Tektronix TDS640 digital scope set to full bandwidth.

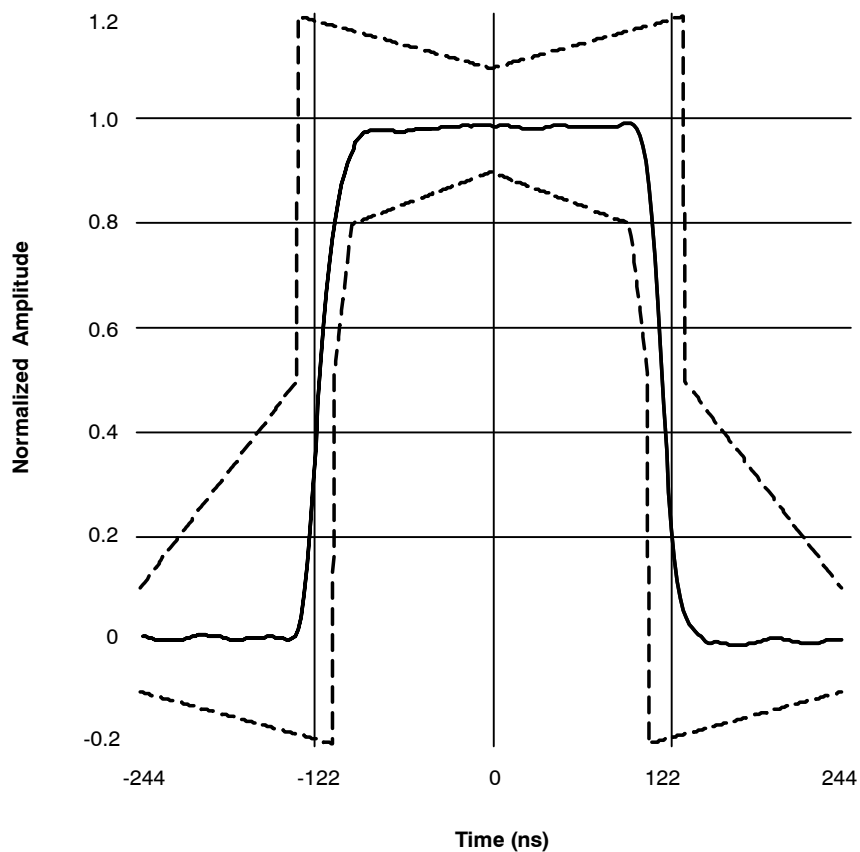

Figure 5. XRT5897 Output Pulse

## Transmitter Output Return Loss Measurements

The following measurements were made with a Wandel and Goltermann SNA-2 Network Analyzer equipped with an RFZ-1 75Ω Return Loss Bridge. A 75Ω to 120Ω impedance matching transformer was used to make the 120Ω measurement. A network analyzer calibration run subtracted out the effects of this transformer.

Test Conditions:

- Output transformer ratio was 1:2.
- Transmitter series resistors (R3 and R4 in *Figure 1*) were 9.1Ω.
- Device was powered from a 3.3V source, transmitter was enabled, and no output data was present.

This configuration was used for both 75Ω and 120Ω measurements. The only change was the termination resistance provided by the return loss bridge.

### Test Results:

*Table 5* compares measured output return loss with requirements in ETSI FINAL DRAFT prETS 300 166, June 1993. These results show that measured return loss is mainly determined by the characteristics of the output transformer. This is particularly evident for the 120Ω load where the measured result is better than the calculated value.

Specified Frequency	Frequency (KHz)	ETSI Spec. (Min. dB)	Meas. Value (dB) 75Ω Load	Meas. Value (dB) 120Ω Load
0.025 fb	51.2	6	22.6	15.4
0.05 fb	102.4	8	22.6	15.7
1.5 fb	3072	8	18.0	14.6

**Table 5. Transmitter Output Return Loss Measurements**

### Notes:

*fb* = 2048KHz

This data shows that the XRT5897 is fully compliant with the ETSI Output Return Loss Specification for E1 operation with either 75Ω or 120Ω loads.

The following pictures show typical results of measurements that made over a 50 KHz to 3.5MHz frequency range.

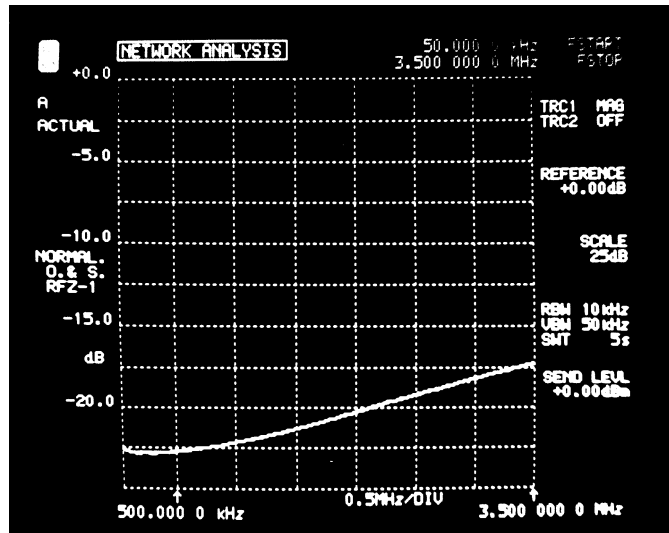

Figure 6. 75Ω Return Loss Measurement

Figure 6, shows a return loss better than 20dB at low frequencies that decreases to about 12dB at 3.5MHz. Since the source and load resistances are well-matched, the return loss degradation is due to the transformer.

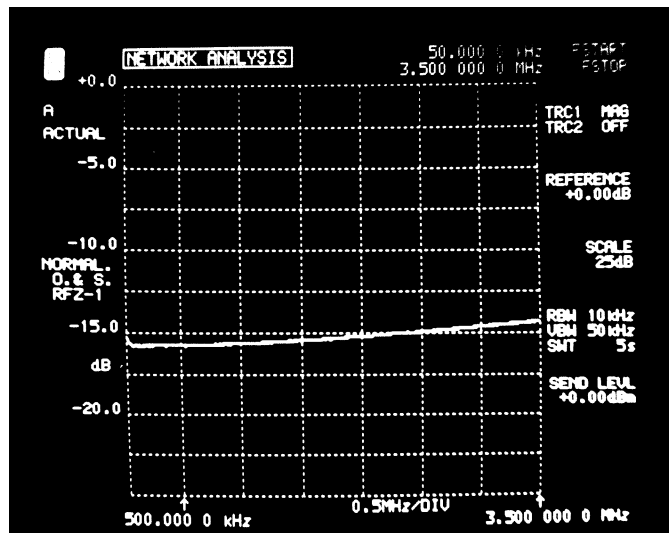

Figure 7. 120Ω Return Loss Measurement

Figure 7, shows that for the 120Ω case, transformer characteristics improve return loss at lower frequencies. At 3.5 MHz, return loss is close to the calculated 13.8dB for a 75Ω source terminated with 120Ω.

## Output Transformer Selection

A 1:2 ratio transformer is recommended for both 75Ω and 120Ω operation because the transmitter, when equipped with this device, meets both the ITU G.703 output pulse amplitude requirement and, the ETSI return loss specification. Although a center-tapped output transformer is not required, choosing a part with a center-tapped secondary allows the use of the same type of unit at the receiver input.

A theoretical justification for the 1:2 ratio transformer follows:

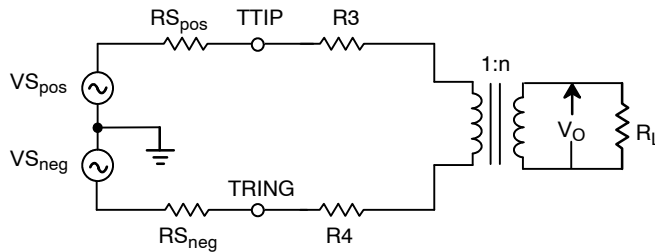

**Figure 8. Transmitter Line Driver Model**

Where:

$V_{S_{pos}} = V_{S_{neg}} = 1.25V$  typical (Differential line driver peak output voltage swing)

$R_{S_{pos}} = R_{S_{neg}} = 0.8\Omega$  typical (Differential line driver internal source resistance)

$R_3 = R_4 = 9.1\Omega$  (Differential line driver external source resistance from *Figure 1*)

$R_L = 75\Omega$  or  $120\Omega$  (Transmitter load resistance)

$n = 2$  (Transformer turns ratio)

$V_o =$  Transmitter peak output voltage (Measured across  $R_L = 75\Omega$  or  $R_L = 120\Omega$ )

*Figure 9* may be converted to a single-ended model:

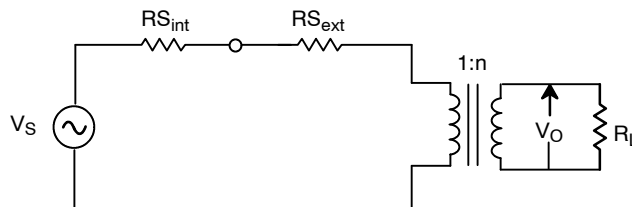

**Figure 9. Single-ended Line Driver Model**

Where:

$V_S = |V_{S_{pos}}| + |V_{S_{neg}}|$

$R_{S_{int}} = R_{S_{pos}} + R_{S_{neg}}$

$R_{S_{ext}} = R_3 + R_4$

This may be further simplified:

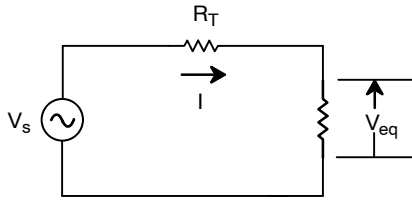

**Figure 10. Equivalent Circuit**

Where:

$$R_T = R_{S_{int}} + R_{S_{ext}}$$

$$R_{eq} = \frac{R_L}{n^2}$$

Therefore:

$$I = \frac{V_s}{R_T + R_{eq}}$$

$$V_{eq} = I R_{eq}$$

$$V_o = n V_{eq}$$

And:

$$\text{Return Loss} = 20 \log \left| \frac{R_T + R_{eq}}{R_T - R_{eq}} \right|$$

Table 6. contains the results of calculations made with these equations. The numbers show that output pulse amplitude is within millivolts of the nominal values of 2.37V and 3.00V specified by ITU G.703 for 75Ω and 120Ω operation. Also, the 1:2 ratio transformer provides an almost-perfect match for 75Ω operation, and return loss is well within the ETSI specification for the 120Ω load.

Load Resistance $R_L$ (Ω)	Pulse Amplitude $V_o$ (Volts Peak)	Output Return Loss (dB)
75	2.43	31.3
120	3.01	13.8

**Table 6. Calculated Transmitter Pulse Amplitude and Return Loss**

## 100 LEAD THIN QUAD FLAT PACK (14 x 14 x 1.4 mm, TQFP)

Rev. 2.00

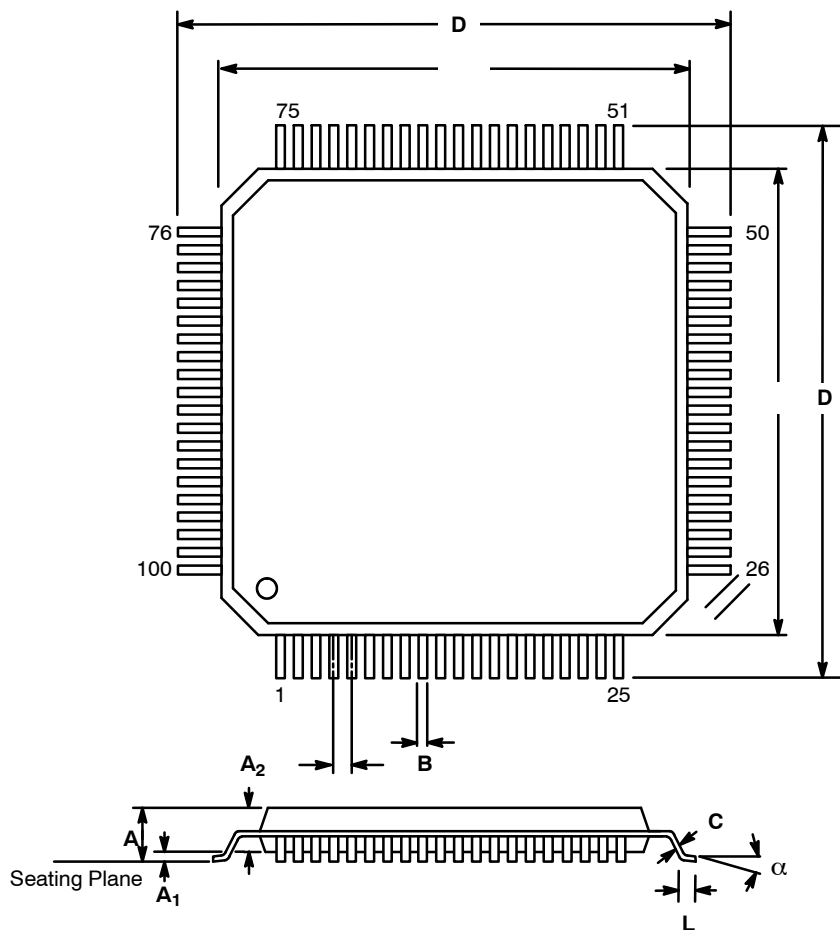

SYMBOL	INCHES		MILLIMETERS	
	MIN	MAX	MIN	MAX
A	0.055	0.063	1.40	1.60
A <sub>1</sub>	0.002	0.006	0.05	0.15
A <sub>2</sub>	0.053	0.057	1.35	1.45
B	0.007	0.011	0.17	0.27
C	0.004	0.008	0.09	0.20
D	0.622	0.638	15.80	16.20
D <sub>1</sub>	0.547	0.555	13.90	14.10
e	0.020 BSC		0.50 BSC	
L	0.018	0.030	0.45	0.75
$\alpha$	0° 7°		0° 7°	

Note: The control dimension is the millimeter column

## NOTICE

EXAR Corporation reserves the right to make changes to the products contained in this publication in order to improve design, performance or reliability. EXAR Corporation assumes no responsibility for the use of any circuits described herein, conveys no license under any patent or other right, and makes no representation that the circuits are free of patent infringement. Charts and schedules contained herein are only for illustration purposes and may vary depending upon a user's specific application. While the information in this publication has been carefully checked; no responsibility, however, is assumed for inaccuracies.

EXAR Corporation does not recommend the use of any of its products in life support applications where the failure or malfunction of the product can reasonably be expected to cause failure of the life support system or to significantly affect its safety or effectiveness. Products are not authorized for use in such applications unless EXAR Corporation receives, in writing, assurances to its satisfaction that: (a) the risk of injury or damage has been minimized; (b) the user assumes all such risks; (c) potential liability of EXAR Corporation is adequately protected under the circumstances.

Copyright 2001 EXAR Corporation

Datasheet October 2001

Reproduction, in part or whole, without the prior written consent of EXAR Corporation is prohibited.

## Looking for pricing, stock, or lifecycle information?

Click below to explore more details on WIN SOURCE:

 [View LM399H#PBF](#) on WIN SOURCE

 [Linear Technology](#) Information

## Optimize Your Supply Chain with WIN SOURCE Solutions

-  Global Sourcing Solution
-  Obsolete Management
-  Cost Control Management
-  Shortage Management
-  Alternative Solution
-  Excess Inventory Management