



**THE DATASHEET OF
LM3824MM-1.0/NOPB**



LM3822

Precision Current Gauge IC with Internal Zero Ohm Sense Element and PWM Output

General Description

The LM3822 Current Gauge provides easy to use precision current measurement with virtually zero insertion loss (typically 0.003Ω). The LM3822 is used for high-side sensing.

A Delta Sigma analog to digital converter is incorporated to precisely measure the current and to provide a current averaging function. Current is averaged over 50 msec time periods in order to provide immunity to current spikes. The ICs have a pulse-width modulated (PWM) output which indicates the current magnitude and direction. The shutdown pin can be used to inhibit false triggering during start-up, or to enter a low quiescent current mode.

The LM3822 is factory-set in two different current options. The sense range is -1.0A to +1.0A or -2.0A to +2.0A. The sampling interval for this part is 50ms. If faster sampling is desired, please refer to the data sheet for the part number LM3824.

Key Specifications

- Ultra low insertion loss (typically 0.003Ω)
- 2V to 5.5V supply range
- ±2% accuracy at room temperature for the 1A device (includes accuracy of the internal sense element)

- Low quiescent current in shutdown mode (typically 1.8 μA)
- 50 msec sampling interval
- In MSOP-8 Package

Features

- No external sense element required
- PWM output indicates the current magnitude and direction
- PWM output is easily interfaced with microprocessors and controllers
- Precision ΔΣ current-sense technique
- Low temperature sensitivity
- Internal filtering rejects false trips
- Internal Power-On-Reset (POR)
- DC Offset is less than 1 mA for 1A part

Applications

- Battery charge/discharge gauge
- Motion control diagnostics
- Power supply load monitoring and management
- Resettable smart fuse

Connection Diagram

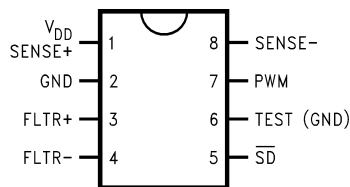

10124901

Top View
LM3822 for High-Side Sensing

Ordering Information

Order No.*	Sense Range	Sampling Interval*	Sensing Method	NS Package Number	Package Type	Supplied As:
LM3822MM-1.0	±1.0A	50 ms	High-side	MUA08A	MSOP-8	Tape and Reel (1000 units/reel)
LM3822MMX-1.0	±1.0A	50 ms	High-side	MUA08A	MSOP-8	Tape and Reel (3500 units/reel)
LM3822MM-2.0	±2.0A	50 ms	High-side	MUA08A	MSOP-8	Tape and Reel (1000 units/reel)
LM3822MMX-2.0	±2.0A	50 ms	High-side	MUA08A	MSOP-8	Tape and Reel (3500 units/reel)

* Current is sampled over a fixed interval. The average current during this interval is indicated by the duty cycle of the PWM output during next interval.

Pin Description (High-Side, LM3822)

Pin	Name	Function
1	SENSE+, V_{DD}	High side of internal current sense, also supply voltage.
2	GND	Supply Ground.
3	FLTR+	Filter input — provides anti-aliasing for delta sigma modulator.
4	FLTR-	Filter input.
5	\overline{SD}	Shutdown input. Connected to V_{DD} through a pull-up resistor for normal operation. When low, the LM3822 is put into a low current mode.
6	TEST	Connect to GND for normal operation.
7	PWM	Digital output indicates the current magnitude and direction.
8	SENSE-	Low side of internal current sense.

Absolute Maximum Ratings (Note 1)

If Military/Aerospace specified devices are required, please contact the National Semiconductor Sales Office/Distributors for availability and specifications.

Absolute Maximum Supply Voltage	5.5V
Power Dissipation	(Note 2)
ESD Susceptibility (Note 3)	1.5 kV
Sense Current (peak, for 200 msec) (Note 4)	10A
Sink Current for PWM pin	1mA
Maximum Junction Temperature	150°C

Storage Temperature	-65°C to +150°C
Lead Temperature (Soldering, 10 sec)	260°C

Operating Ratings (Note 1)

Input Voltage	2.0V to 5.25V
Sense Current (continuous) (Note 4)	5A
Junction Temperature Range	-40°C to +85°C

Electrical Characteristics Typical numbers are at 25°C and represent the most likely parametric norm. Specifications in standard type face are for $T_J = 25^\circ\text{C}$ and those with **boldface type** apply over **full operating temperature ranges**.

LM3822-1.0

SENSE+ $V_{DD} = 3.6\text{V}$ for the following specifications. Supply bypass capacitor is 1 μF and filter capacitor is 0.1 μF .

Symbol	Parameter	Conditions	Typ (Note 5)	Limit (Note 6)	Units
I_{ACC}	Average Current Accuracy (Note 7)	1.0A current	1.0	0.98 / 0.96 1.02 / 1.04	A A (min) A (max)
e_n	Effective Output Noise (rms)		2		mA

LM3822-2.0

SENSE+ $V_{DD} = 3.6\text{V}$ for the following specifications. Supply bypass capacitor is 1 μF and filter capacitor is 0.1 μF .

Symbol	Parameter	Conditions	Typ (Note 5)	Limit (Note 6)	Units
I_{ACC}	Average Current Accuracy (Note 7)	2.0A current (Note 8)	2.0	1.94 / 1.90 2.06 / 2.10	A A (min) A (max)
e_n	Effective Output Noise (rms)		6		mA

Common Device Parameters

Unless otherwise specified, $V_{DD} = 3.6\text{V}$ for the following specifications. Supply bypass capacitor is 1 μF and filter capacitor is 0.1 μF .

Symbol	Parameter	Conditions	Typ (Note 5)	Limit (Note 6)	Units
I_{Q1}	Quiescent Current	Normal Mode, $\overline{SD} = \text{high}$	95	150	μA μA (max)
I_{Q2}	Quiescent Current	Shutdown Mode, $\overline{SD} = \text{low}$	1.8	10	μA μA (max)
D_{RES}	PWM Resolution		0.1		%
t_S	Sampling Time		50	40 80	ms ms (min) ms (max)
f_P	Frequency of PWM Waveform		20	12.5 25	Hz Hz (min) Hz (max)
V_{TH}	Threshold High Level for \overline{SD}		1.3	1.8	V V (min)

Electrical Characteristics

Typical numbers are at 25°C and represent the most likely parametric norm. Specifications in standard type face are for $T_J = 25^\circ\text{C}$ and those with **boldface type** apply over **full operating temperature ranges**. (Continued)

Common Device Parameters

(Continued)
Unless otherwise specified, $V_{DD} = 3.6\text{V}$ for the following specifications. Supply bypass capacitor is 1 μF and filter capacitor is 0.1 μF .

Symbol	Parameter	Conditions	Typ (Note 5)	Limit (Note 6)	Units
V_{TL}	Threshold Low Level for \overline{SD}		1.2	0.7	V V (max)
V_{OH}	Logic High Level for PWM	Load current = 1 mA, $2\text{V} \leq V_{DD} \leq 5.25\text{V}$	$V_{DD} - 0.05$	$V_{DD} - 0.2$	V V (min)
V_{OL}	Logic Low Level for PWM	Sink current = 1 mA, $2\text{V} \leq V_{DD} \leq 5.25\text{V}$	0.04	0.2	V V (max)
P_I	Insertion Loss	$I_{SENSE} = 1\text{A}$ (Note 9)	0.003		Ω

Note 1: Absolute Maximum Ratings indicate limits beyond which damage to the device may occur. Operating Ratings indicate conditions for which the device is intended to be functional, but do not guarantee specific performance limits. For guaranteed specifications and test conditions, see Electrical Characteristics. The guaranteed specifications apply only for the test conditions listed. Some performance characteristics may degrade when the device is not operated under the listed test conditions.

Note 2: At elevated temperatures, devices must be derated based on package thermal resistance. The device in the surface-mount package must be derated at $\theta_{JA} = 220^\circ\text{C/W}$ (typically), junction-to-ambient.

Note 3: The human body model is a 100 pF capacitor discharged through a 1.5 k Ω resistor into each pin.

Note 4: The absolute maximum peak and continuous currents specified are not tested. These specifications are dependent on the θ_{JA} , which is 220°C/W for the MSOP-8 package.

Note 5: Typical numbers are at 25°C and represent the most likely parametric norm. Specifications in standard type face are for $T_J = 25^\circ\text{C}$ and those with **boldface type** apply over **full operating temperature ranges**.

Note 6: Limits are 100% production tested at 25°C. Limits over the operating temperature range are guaranteed through correlation using Statistical Quality Control (SQC) methods. The limits are used to calculate National's Average Outgoing Quality Level (AOQL).

Note 7: There is a variation in accuracy over time due to thermal effects. Please refer to the "PWM Output and Current Accuracy" section for more information.

Note 8: This parameter is production tested at 1A and guaranteed by design at 2A.

Note 9: The tolerance of the internal lead frame resistor is corrected internally. The temperature coefficient of this resistor is 2600 ppm/°C.

Typical Performance Characteristics

Supply bypass capacitor is 0.1 μF and filter capacitor is 0.1 μF .

Measured Current vs Actual Current (LM3822-1.0)

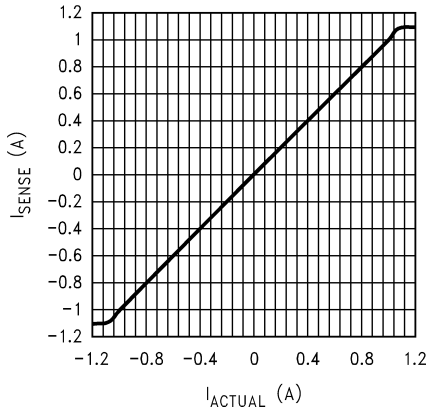

10124924

Measured Current vs Actual Current (LM3822-2.0)

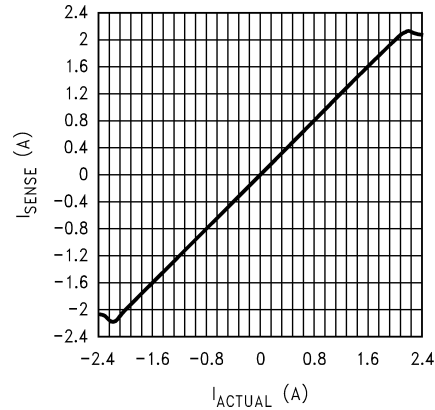

10124925

PWM Frequency vs Supply Voltage

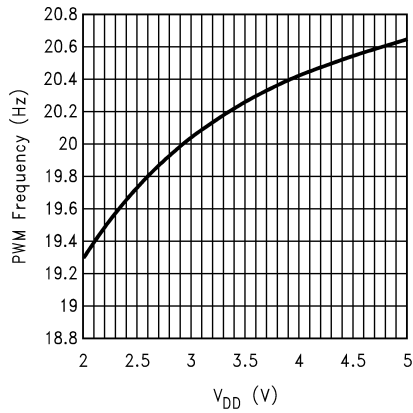

10124933

PWM Frequency vs Temperature

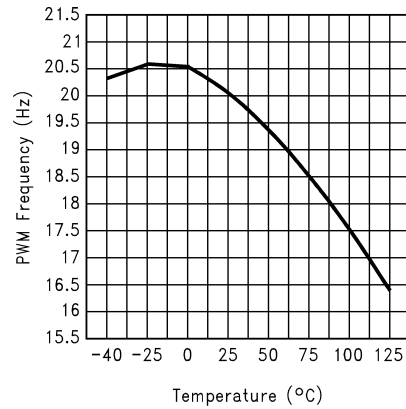

10124923

Operating Current vs Supply Voltage

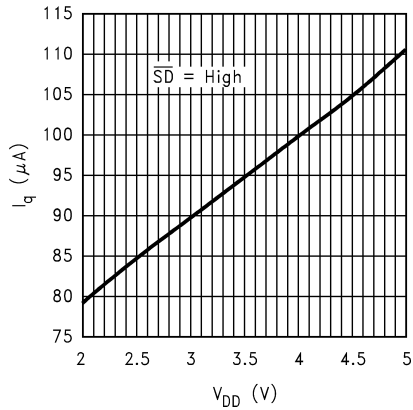

10124918

Shutdown Current vs Supply Voltage

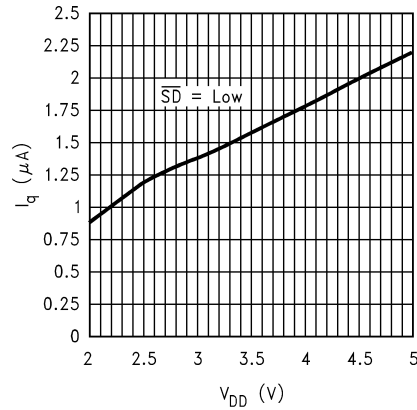

10124920

Typical Performance Characteristics Supply bypass capacitor is 0.1 μF and filter capacitor is 0.1 μF . (Continued)

Operating Current vs Temperature

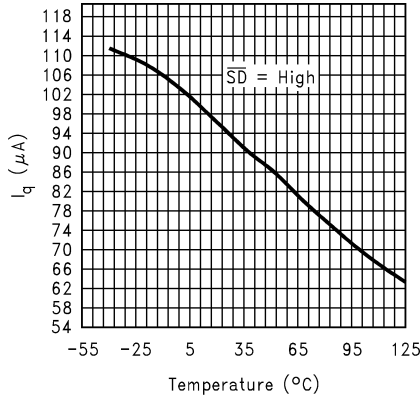

Shutdown Current vs Temperature

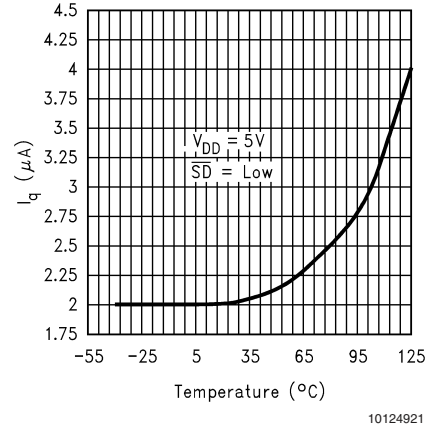

Current vs PWM Duty Cycle

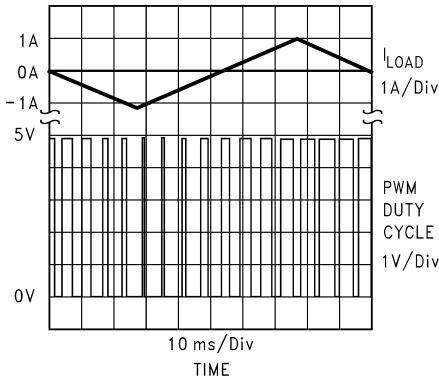

Accuracy vs Supply Voltage

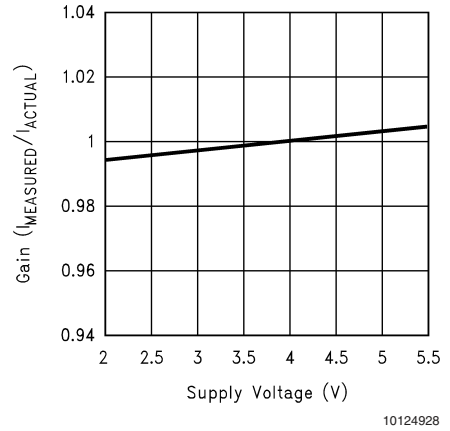

Accuracy vs Temperature (LM3822-1.0)

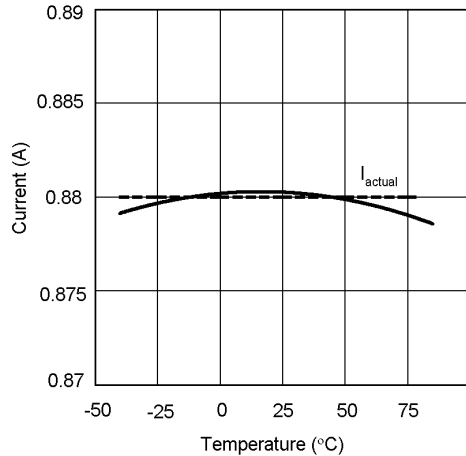

Accuracy vs Temperature (LM3822-2.0)

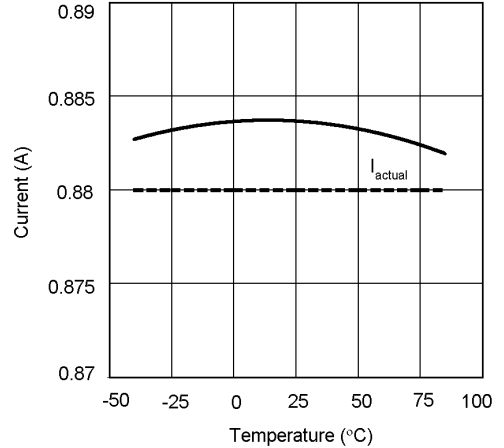

Note 10: These curves represent a statistical average such that the noise is insignificant.

Typical Application Circuits In the application circuits, the 0.1 μF ceramic capacitor between pins 1 and 2 is used for bypassing, and the 0.1 μF ceramic capacitor between pins 3 and 4 is used for filtering. Shutdown ($\overline{\text{SD}}$) is tied to V_{DD} through a 10 k Ω resistor.

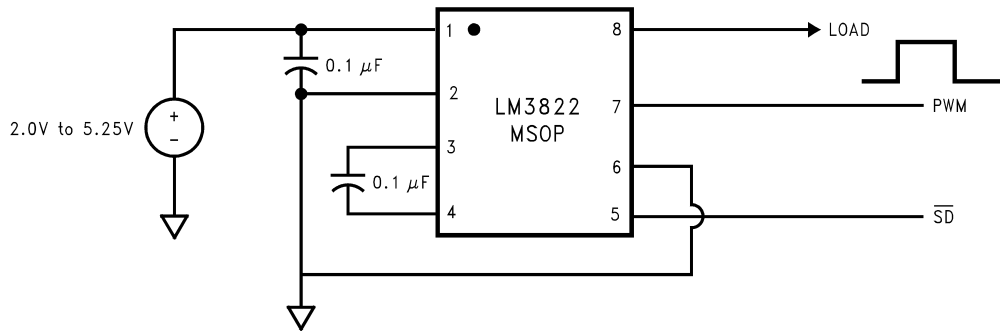

10124905

FIGURE 1. High Side Sense

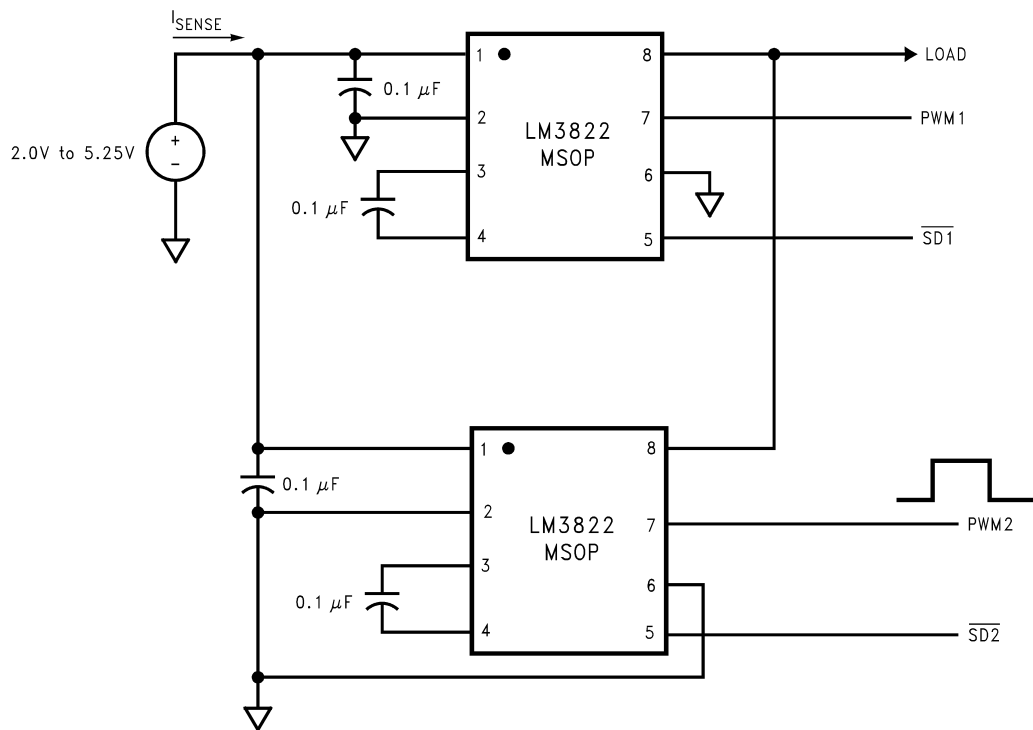

10124907

FIGURE 2. Paralleling LM3822 for Higher Load Current

$$I_{\text{TOTAL}} = 2.2(D_1 - 0.5)I_{\text{MAX}} + 2.2(D_2 - 0.5)I_{\text{MAX}}$$
 where D_1 is the duty cycle of PWM1 and D_2 is the duty cycle of PWM2.
 Please refer to the Product Operation section for more information.

Typical Application Circuits In the application circuits, the $0.1\ \mu\text{F}$ ceramic capacitor between pins 1 and 2 is used for bypassing, and the $0.1\ \mu\text{F}$ ceramic capacitor between pins 3 and 4 is used for filtering. Shutdown ($\overline{\text{SD}}$) is tied to V_{DD} through a $10\ \text{k}\Omega$ resistor. (Continued)

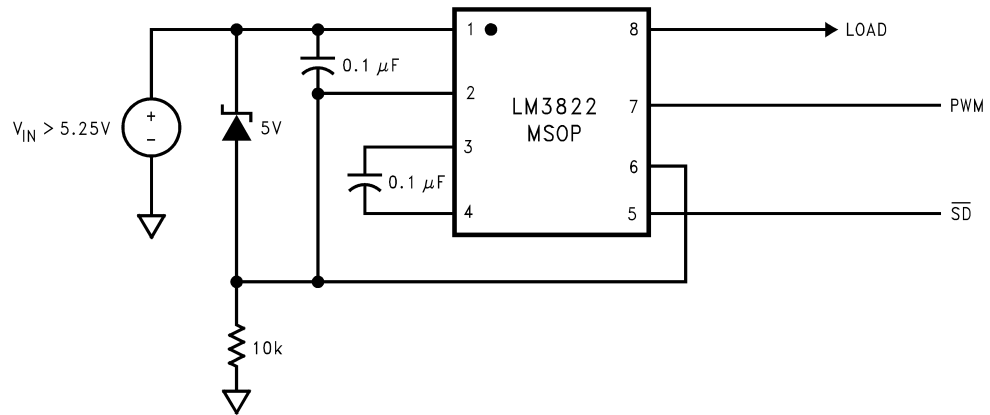

10124908

FIGURE 3. High Voltage Operation — V_{IN} Greater Than 5.5V (High Side Sense)
(PWM output is referred to Pin 6)

Product Operation

The current is sampled by the delta-sigma modulator, as illustrated in *Figure 4*. The pulse density output of the delta-sigma modulator is digitally filtered. The digital output is then compared to the output of a digital ramp generator. This produces a PWM output. The duty cycle of the PWM output is proportional to the amount of current flowing. A duty cycle of 50% indicates zero current flow. If the current is flowing in positive direction, the duty cycle will be greater than 50%. Conversely, the duty cycle will be less than 50% for currents flowing in the negative direction. A duty cycle of 95.5% (4.5%) indicates the current is at I_{MAX} ($-I_{MAX}$). The IC can sense currents from $-I_{MAX}$ to $+I_{MAX}$. Options for I_{MAX} are 1.0A or 2.0A. The sense current is given by:

$$I_{SENSE} = 2.2 (D - 0.5) (I_{MAX})$$

where D is the duty cycle of the PWM waveform, and I_{MAX} is the full scale current (1.00A or 2.00A). Similarly, the duty cycle is given by:

$$D = [I_{SENSE} / (2.2 I_{MAX})] + 0.5$$

For quick reference, see the Conversion Table in *Table 1*.

In this IC, the current is averaged over 50 msec time slots. Hence, momentary current surges of less than 50 msec are tolerated.

This is a sampled data system which requires an anti-aliasing filter, provided by the filter capacitor.

The delta-sigma modulator converts the sensed current to the digital domain. This allows digital filtering, and provides immunity to current and noise spikes. This type of filtering would be difficult or impossible to accomplish on an IC with analog components.

The user also needs to specify the full scale value. See the Ordering Information table for details.

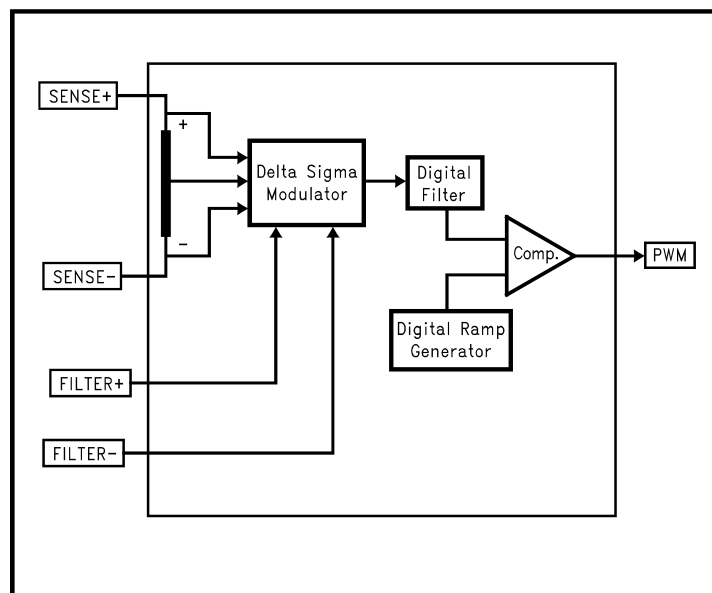

10124910

FIGURE 4. Functional block diagram of LM3822

PWM Output and Current Accuracy

OFFSET

The PWM output is quantized to 1024 levels. Therefore, the duty cycle can change only in increments of $1/1024$.

There is a one-half (0.5) quantization cycle delay in the output of the PWM circuitry. That is to say that instead of a duty cycle of $N/1024$, the duty cycle actually is $(N+1/2)/1024$.

The quantization error can be corrected for if a more precise result is desired. To correct for this error, simply subtract $1/2048$ from the measured duty cycle.

The extra half cycle delay will show up as a DC offset of $1/2$ bit if it is not corrected for. This is approximately 1.0 mA for 1.0 Amp parts, and 10 mA for 2.0 Amp parts.

JITTER

In addition to quantization, the duty cycle will contain some jitter. The jitter is quite small (for example, the standard deviation of jitter is only 0.1% for the LM3822-1.0). Statistically the jitter can cause an error in a current sample. Because the jitter is a random variable, the mean and standard deviation are used. The mean, or average value, of the jitter is zero. The standard deviation (0.1%) can be used to define the peak error caused from jitter.

The “crest factor” has often been used to define the maximum error caused by jitter. The crest factor defines a limit within which 99.7% of the samples fall. The crest factor is defined as $\pm 0.3\%$ error in the duty cycle.

Since the jitter is a random variable, averaging multiple outputs will reduce the effective jitter. Obeying statistical laws, the jitter is reduced by the square root of the number of readings that are averaged. For example, if four readings of the duty cycle are averaged, the resulting jitter (and crest factor) are reduced by a factor of two.

JITTER AND NOISE

Jitter in the PWM output appears as noise in the current measurement. The Electrical Characteristics show noise measured in current RMS (root mean square). Arbitrarily one could specify PWM jitter, as opposed to noise. In either case the effect results in a random error in an individual current measurement.

Noise, just like jitter, can be reduced by averaging many readings. The RMS value of the noise corresponds to one standard deviation. The “crest factor” can be calculated in terms of current, and is equal to ± 3 sigma (RMS value of the noise).

Noise will also be reduced by averaging multiple readings, and follows the statistical laws of a random variable.

ACCURACY VERSUS NOISE

The graph shown in *Figure 5* illustrates the typical response of ± 1 Ampere current gauges. In this graph, the horizontal axis indicates time, and the vertical axis indicates measured current (the PWM duty cycle has been converted to current). The graph was generated for an actual current of 500 mA.

The difference between successive readings manifests itself as jitter in the PWM output or noise in the current measurement (when duty cycle of the PWM output is converted to current).

The accuracy of the measurement depends on the noise in the current waveform. The accuracy can be improved by averaging several outputs. Although there is variation in successive readings, a very accurate measurement can be obtained by averaging the readings. For example, on averaging the readings shown in this example, the average current measurement is 502.3 mA (*Figure 5*). This value is very close to the actual value of 500 mA. Moreover, the accuracy depends on the number of readings that are averaged.

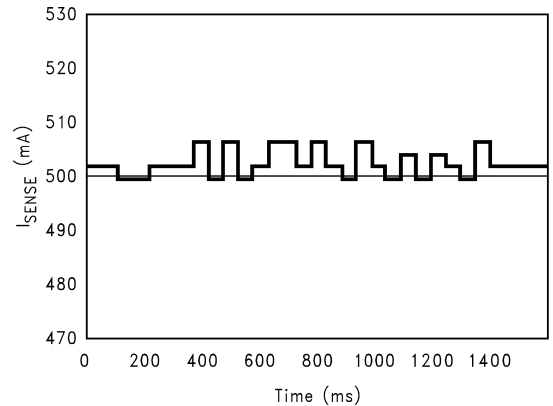

FIGURE 5. Typical Response of LM3822

LOW CURRENT MEASUREMENTS

The DC offset of the LM3822-1.0 is typically under 1 mA. This low offset allows accurate low current measurements. Even currents in the 10 mA range can be measured with accuracies typically better than $\pm 5\%$.

Look-Up Tables

The following tables show how to convert the duty cycle of the PWM output to a current value, and vice versa. The

quantization error of $\frac{1}{2}$ bit is not shown in these tables. Please see the "PWM Output and Current Accuracy" section for more details.

TABLE 1. Current to Duty Cycle Conversion Table

Sense Current ($I_{max} = 1.0A$)	Sense Current ($I_{max} = 2.0A$)	Duty Cycle (%)
1	2	95.5
0.95	1.90	93.2
0.90	1.80	90.9
0.85	1.70	88.6
0.80	1.60	86.4
0.75	1.50	84.1
0.70	1.40	81.8
0.65	1.30	79.5
0.60	1.20	77.3
0.55	1.10	75.0
0.50	1	72.7
0.45	0.90	70.5
0.40	0.80	68.2
0.35	0.70	65.9
0.30	0.60	63.6
0.25	0.50	61.4
0.20	0.40	59.1
0.15	0.30	56.8
0.10	0.20	54.5
0.05	0.10	52.3
0.00	0.00	50
-0.05	-0.10	47.7
-0.10	-0.20	45.5
-0.15	-0.30	43.2
-0.20	-0.40	40.9
-0.25	-0.50	38.6
-0.30	-0.60	36.4
-0.35	-0.70	34.1
-0.40	-0.80	31.8
-0.45	-0.90	29.5
-0.50	-1	27.3
-0.55	-1.10	25
-0.60	-1.20	22.7
-0.65	-1.30	20.5
-0.70	-1.40	18.2
-0.75	-1.50	15.9
-0.80	-1.60	13.6
-0.85	-1.70	11.4
-0.90	-1.80	9.1
-0.95	-1.90	6.8
-1	-2	4.5

Timing Diagram

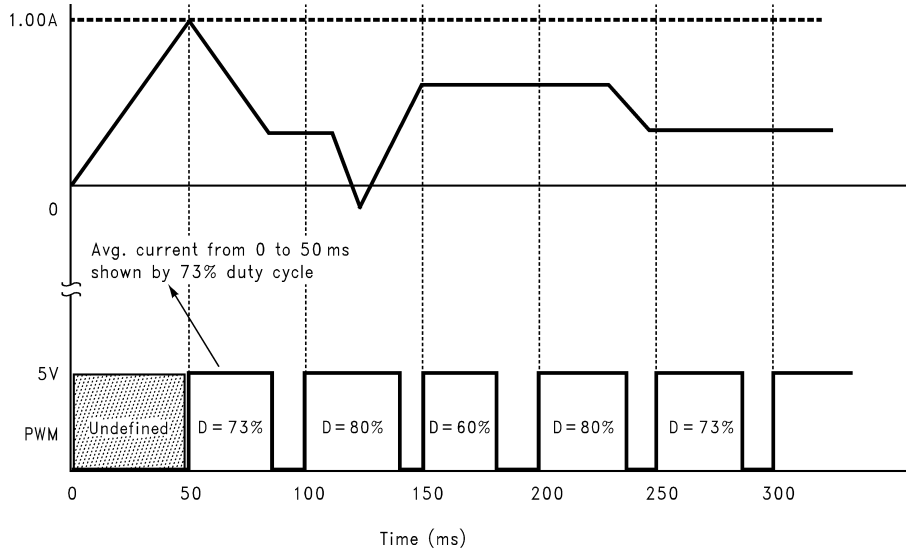

10124911

Duty cycle of the PWM waveform during any sampling interval indicates the current magnitude (average) and direction during the previous sampling interval.

FIGURE 6. Typical Timing Diagram for Mostly Positive Current

Physical Dimensions inches (millimeters) unless otherwise noted

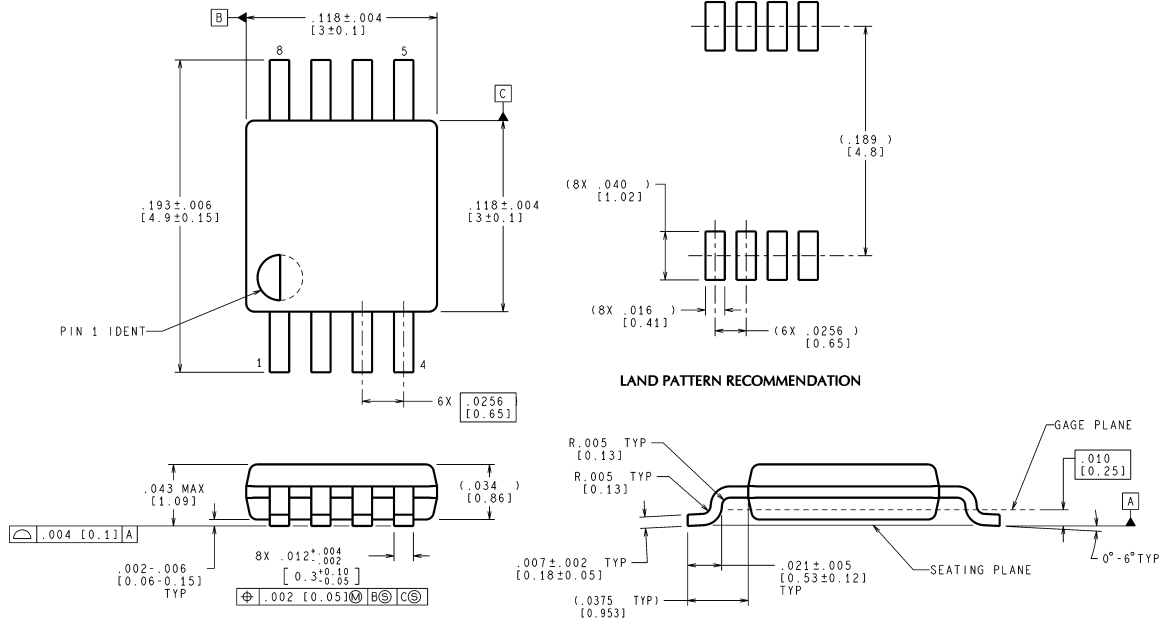

MUA08A (Rev E)

8-Lead MSOP
See Ordering Information table for Order Numbers
NS Package Number MUA08A

National does not assume any responsibility for use of any circuitry described, no circuit patent licenses are implied and National reserves the right at any time without notice to change said circuitry and specifications.

For the most current product information visit us at www.national.com.

LIFE SUPPORT POLICY

NATIONAL'S PRODUCTS ARE NOT AUTHORIZED FOR USE AS CRITICAL COMPONENTS IN LIFE SUPPORT DEVICES OR SYSTEMS WITHOUT THE EXPRESS WRITTEN APPROVAL OF THE PRESIDENT AND GENERAL COUNSEL OF NATIONAL SEMICONDUCTOR CORPORATION. As used herein:

1. Life support devices or systems are devices or systems which, (a) are intended for surgical implant into the body, or (b) support or sustain life, and whose failure to perform when properly used in accordance with instructions for use provided in the labeling, can be reasonably expected to result in a significant injury to the user.
2. A critical component is any component of a life support device or system whose failure to perform can be reasonably expected to cause the failure of the life support device or system, or to affect its safety or effectiveness.

BANNED SUBSTANCE COMPLIANCE

National Semiconductor certifies that the products and packing materials meet the provisions of the Customer Products Stewardship Specification (CSP-9-111C2) and the Banned Substances and Materials of Interest Specification (CSP-9-111S2) and contain no "Banned Substances" as defined in CSP-9-111S2.



National Semiconductor
Americas Customer Support Center
 Email: new.feedback@nsc.com
 Tel: 1-800-272-9959

National Semiconductor
Europe Customer Support Center
 Fax: +49 (0) 180-530 85 86
 Email: europe.support@nsc.com
 Deutsch Tel: +49 (0) 69 9508 6208
 English Tel: +44 (0) 870 24 0 2171
 Français Tel: +33 (0) 1 41 91 8790

National Semiconductor
Asia Pacific Customer Support Center
 Email: ap.support@nsc.com

National Semiconductor
Japan Customer Support Center
 Fax: 81-3-5639-7507
 Email: jpn.feedback@nsc.com
 Tel: 81-3-5639-7560

Looking for pricing, stock, or lifecycle information?

Click below to explore more details on WIN SOURCE:

- ⊖ [View LM3824MM-1.0/NOPB on WIN SOURCE](#)
- ⊖ [Texas Instruments](#) Information

Optimize Your Supply Chain with WIN SOURCE Solutions

- ✓ Global Sourcing Solution
- ✓ Obsolete Management
- ✓ Cost Control Management
- ✓ Shortage Management
- ✓ Alternative Solution
- ✓ Excess Inventory Management