



# THE DATASHEET OF LM3549SQEV/NOPB



# LM3549 High Power Sequential LED Driver

 Check for Samples: [LM3549](#)

## FEATURES

- Over-Current Protection
- Over-Temperature Protection
- I<sup>2</sup>C Compatible Interface
- Under-Voltage Lockout
- LED Open and Short Protection and Detection
- 95% Peak Efficiency Buck-Boost Converter
- NVM Memory for Calibration Data and Standalone Usage without I<sup>2</sup>C Control
- Soft Start

## APPLICATIONS

- Portable Video Projectors
- High Power LED Driving

## KEY SPECIFICATIONS

- Integrated buck-boost Converter
- Programmable LED Drivers
- 700 mA Maximum Drive Current
- ±6% Current Accuracy Over Temperature
- 24-pin WQFN Package

## DESCRIPTION

The LM3549 is a high power LED driver with up to 700mA output current. It has three constant current LED drivers and a buck boost SMPS for driving RGB LEDs with high efficiency. LED drivers are designed for sequential drive so only one driver can be enabled at a time.

LED driver output current settings can be stored to integrated non-volatile memory which allows stand-alone operation without I<sup>2</sup>C interface. Non-volatile memory is rewritable so current setting can be changed if needed.

The LM3549 has a fault detection feature that can detect several different fault conditions. In case of a fault error flags are set and FAULT output sends interrupt to control logic. Error flags can be read through I<sup>2</sup>C interface.

Total brightness can be controlled with PWM input or with master fader register if I<sup>2</sup>C interface is used.

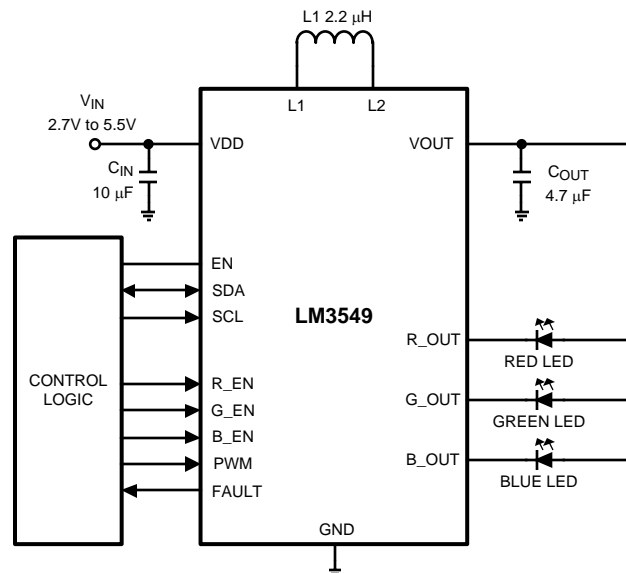
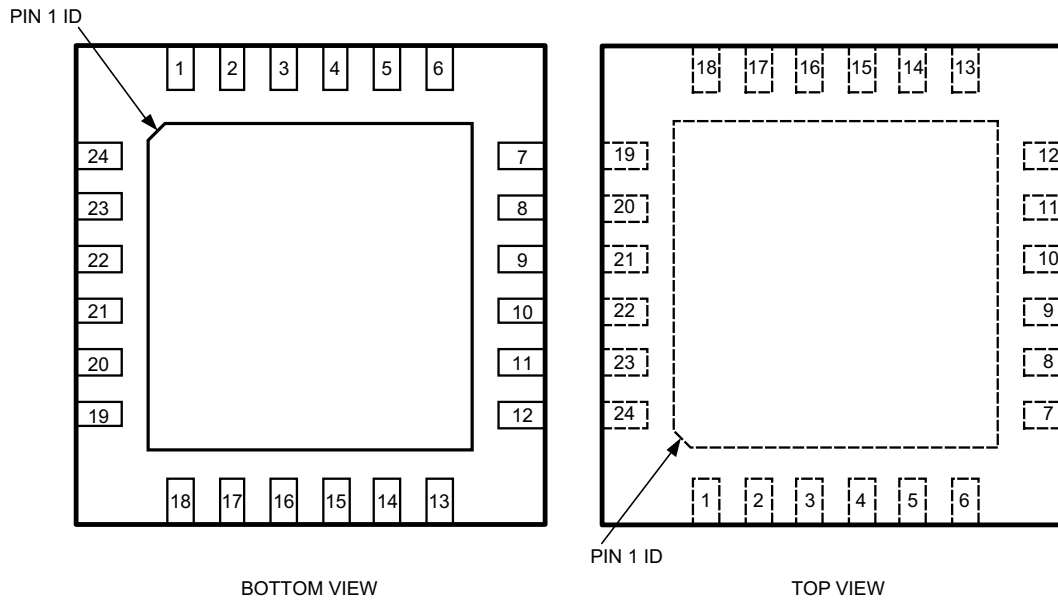

Figure 1. Typical Application Circuit



Please be aware that an important notice concerning availability, standard warranty, and use in critical applications of Texas Instruments semiconductor products and disclaimers thereto appears at the end of this data sheet.

All trademarks are the property of their respective owners.



**Figure 2. 24-Pin WQFN Package, No Pullback**  
See package number RTW0024A

### Pin Descriptions

Name	Pin No.	Type	Description
NC	1		
L1	2	A	Inductor positive terminal 1
L1	3	A	Inductor positive terminal 2
GND_SW	4	G	SMPS ground
L2	5	A	Inductor negative terminal 1
L2	6	A	Inductor negative terminal 2
VOUT	7	A	Buck boost output terminal 1
NC	8		
VOUT	9	A	Buck boost output terminal 2
R_EN	10	DI	Red output enable
VDDS	11	P	Supply voltage
G_EN	12	DI	Green output enable
B_EN	13	DI	Blue output enable
PWM	14	DI	Master fader input
GND	15	G	Ground
R_OUT	16	A	R output
G_OUT	17	A	G output
B_OUT	18	A	B output
FAULT	19	DO	Fault detection interrupts output. Active LOW open drain output.
SDA	20	DI/O	I2C Data
SCL	21	DI	I2C Clock
EN	22	DI	Enable and IO reference level
VDDP	23	P	SMPS supply voltage
NC	24		



These devices have limited built-in ESD protection. The leads should be shorted together or the device placed in conductive foam during storage or handling to prevent electrostatic damage to the MOS gates.

### Absolute Maximum Ratings <sup>(1) (2)(3)</sup>

VDD and VOUT pins	-0.3V to 6.0V
Voltage on all other pins	-0.3V (V <sub>IN</sub> +0.3V) w/6.0V max
Continuous Power Dissipation <sup>(4)</sup>	Internally Limited
Junction Temperature (T <sub>J-MAX</sub> )	+150°C
Storage Temperature Range	-65°C to +150°C
Maximum Lead Temperature (Soldering)	<sup>(5)</sup>
ESD Rating <sup>(6)</sup>	
Human Body Model	2.0kV

- (1) Absolute Maximum Ratings indicate limits beyond which damage to the component may occur. Operating Ratings are conditions under which operation of the device is specified. Operating Ratings do not imply performance limits. For performance limits and associated test conditions, see the Electrical Characteristics tables.
- (2) All voltages are with respect to the potential at the GND pin.
- (3) If Military/Aerospace specified devices are required, please contact the TI Sales Office/Distributors for availability and specifications.
- (4) Internal thermal shutdown circuitry protects the device from permanent damage. Thermal shutdown engages at T<sub>J</sub>=+150°C (typ.) and disengages at T<sub>J</sub>=+140°C (typ.).
- (5) For detailed soldering specifications and information, please refer to **Application Note AN-1187: Leadless Leadframe Package (LLP)**. (SNOA401)
- (6) The Human body model is a 100 pF capacitor discharged through a 1.5 kΩ resistor into each pin. (MIL-STD-883 3015.7)

### Operating Ratings <sup>(1) (2)</sup>

Input Voltage Range	2.7V to 5.5V
Junction Temperature (T <sub>J</sub> ) Range	-30°C to +125°C
Ambient Temperature (T <sub>A</sub> ) Range <sup>(3)</sup>	-30°C to +85°C

- (1) Absolute Maximum Ratings indicate limits beyond which damage to the component may occur. Operating Ratings are conditions under which operation of the device is specified. Operating Ratings do not imply performance limits. For performance limits and associated test conditions, see the Electrical Characteristics tables.
- (2) All voltages are with respect to the potential at the GND pin.
- (3) In applications where high-power dissipation and/or poor package thermal resistance is present, the maximum ambient temperature may have to be derated. Maximum ambient temperature (T<sub>A-MAX</sub>) is dependent on the maximum operating junction temperature (T<sub>J-MAX-OP</sub> = +125°C), the maximum power dissipation of the device in the application (P<sub>D-MAX</sub>), and the junction-to ambient thermal resistance of the part/package in the application (θ<sub>JA</sub>), as given by the following equation: T<sub>A-MAX</sub> = T<sub>J-MAX-OP</sub> - (θ<sub>JA</sub> × P<sub>D-MAX</sub>).

### Thermal Properties

Junction-to-Ambient Thermal Resistance (θ <sub>JA</sub> ), WQFN-24 Package <sup>(1)</sup>	35 - 50°C/W
---	-------------

- (1) Junction-to-ambient thermal resistance is highly application and board-layout dependent. In applications where high maximum power dissipation exists, special care must be paid to thermal dissipation issues in board design.

### Electrical Characteristics <sup>(1) (2)</sup>

Limits in standard type face are for T<sub>A</sub> = 25°C. Limits in **boldface type** apply over the full operating ambient temperature range (-30°C ≤ T<sub>A</sub> ≤ +85°C). Unless otherwise noted, specifications apply to [Figure 1](#) with: V<sub>IN</sub> = 3.6V, C<sub>IN</sub> = 10 μF, C<sub>OUT</sub> = 4.7μF and L1 = 2.2 μH. <sup>(3)</sup>

Parameter		Test Conditions	Min	Typ	Max	Units
V <sub>IN</sub>	Supply voltage	Minimum voltage for startup	2.7			V
		Full output power	3.1		5.5	
I <sub>IN</sub> (IVDDP + IVDDS)	Shutdown supply current	EN low			1	μA
	Standby supply current	EN High, x_EN low		0.4	1	mA
I <sub>IN</sub> (IVDDS)	Active mode supply current	EN High, x_EN high, RGB outputs open		1.6	3	mA

- (1) All voltages are with respect to the potential at the GND pin.
- (2) Min and Max limits are specified by design, test, or statistical analysis. Typical (Typ) numbers represent the most likely norm.
- (3) C<sub>IN</sub>, C<sub>OUT</sub>: Low-ESR Surface-Mount Ceramic Capacitors (MLCCs) used in setting electrical characteristics.

## Electrical Characteristics<sup>(1) (2)</sup> (continued)

Limits in standard type face are for  $T_A = 25^\circ\text{C}$ . Limits in **boldface type** apply over the full operating ambient temperature range ( $-30^\circ\text{C} \leq T_A \leq +85^\circ\text{C}$ ). Unless otherwise noted, specifications apply to [Figure 1](#) with:  $V_{IN} = 3.6\text{V}$ ,  $C_{IN} = 10\ \mu\text{F}$ ,  $C_{OUT} = 4.7\ \mu\text{F}$  and  $L1 = 2.2\ \mu\text{H}$ .<sup>(3)</sup>

Parameter		Test Conditions	Min	Typ	Max	Units
<b>Drivers (R_OUT, G_OUT, B_OUT)</b>						
$I_{OUT\ MIN}$	Minimum output current		97	107	118	mA
$I_{OUT\ MAX}$	Maximum output current		690	705	720	mA
$I_{LIM}$	Current limit				15	%
$R_{OUT}$	Driver on resistance	$I_{OUT} = 500\ \text{mA}$		0.2		$\Omega$
<b>Driver System Characteristics</b>						
$I_{OUT}$	Current accuracy	After settling, 500 mA (ISET = 276h)	<b>-6</b>	$\pm 1$	<b>+6</b>	%
$t_r$	Current rise time				50	$\mu\text{s}$
$t_f$	Current fall time				50	$\mu\text{s}$
$I_{STEP}$	Current step			0.64		mA
<b>Buck or Boost Converter</b>						
	Positive current limit range	Programmable	500		2000	mA
	Positive current limit accuracy	Set to 1000 mA	-20		+20	%
	Negative current limit range	Programmable	550		2200	mA
	Negative current limit accuracy	Set to 550 mA	-20		+20	%
$V_{OUT\ MAX}$	Maximum output voltage				4.6	V
$f_{SW}$	Switching frequency		2.25	2.4	2.55	MHz
$r_{DSON\ P1S}$	P1 on resistance in buck mode (small)			100		$\text{m}\Omega$
$r_{DSON\ P1L}$	P1 on resistance in boost mode (large)			55		$\text{m}\Omega$
$r_{DSON\ N1}$	N1 on resistance			160		$\text{m}\Omega$
$r_{DSON\ N3}$	N3 on resistance in buck mode	$V_{OUT} = 0.8\text{V}$		70		$\text{m}\Omega$
$r_{DSON\ P2}$	P2 on resistance in boost mode	$V_{OUT} = 3.6\text{V}$		65		$\text{m}\Omega$
$r_{DSON\ N2}$	N2 on resistance			150		$\text{m}\Omega$
<b>PWM Input (Global brightness control)</b>						
$f_{PWM}$	PWM frequency	7-bit resolution	4		20	kHz
		8-bit resolution	4		10	
		9-bit resolution	4		5	
$t_{TO}$	Timeout	For PWM zero	260	300	340	$\mu\text{s}$
$t_{ON}$	Minimum on time			1		$\mu\text{s}$
$t_{OFF}$	Minimum off time			1		$\mu\text{s}$
<b>Logic Input EN</b>						
VIL	Logic input low level				0.5	V
VIH	Logic input high level		1.2			V
<b>Logic Inputs SDA, SCL, R_EN, G_EN, B_EN, PWM</b>						
VIL	Logic input low level	$V_{EN} = 1.65\ \text{to}\ V_{DD}$			$0.2^* V_{EN}$	V
VIH	Logic input high level	$V_{EN} = 1.65\ \text{to}\ V_{DD}$	$0.8^* V_{EN}$			V
<b>Logic Outputs SDA, FAULT</b>						
VOL	Output low level	$I_{OUT} = 3\ \text{mA}$			0.5	V

BLOCK DIAGRAM

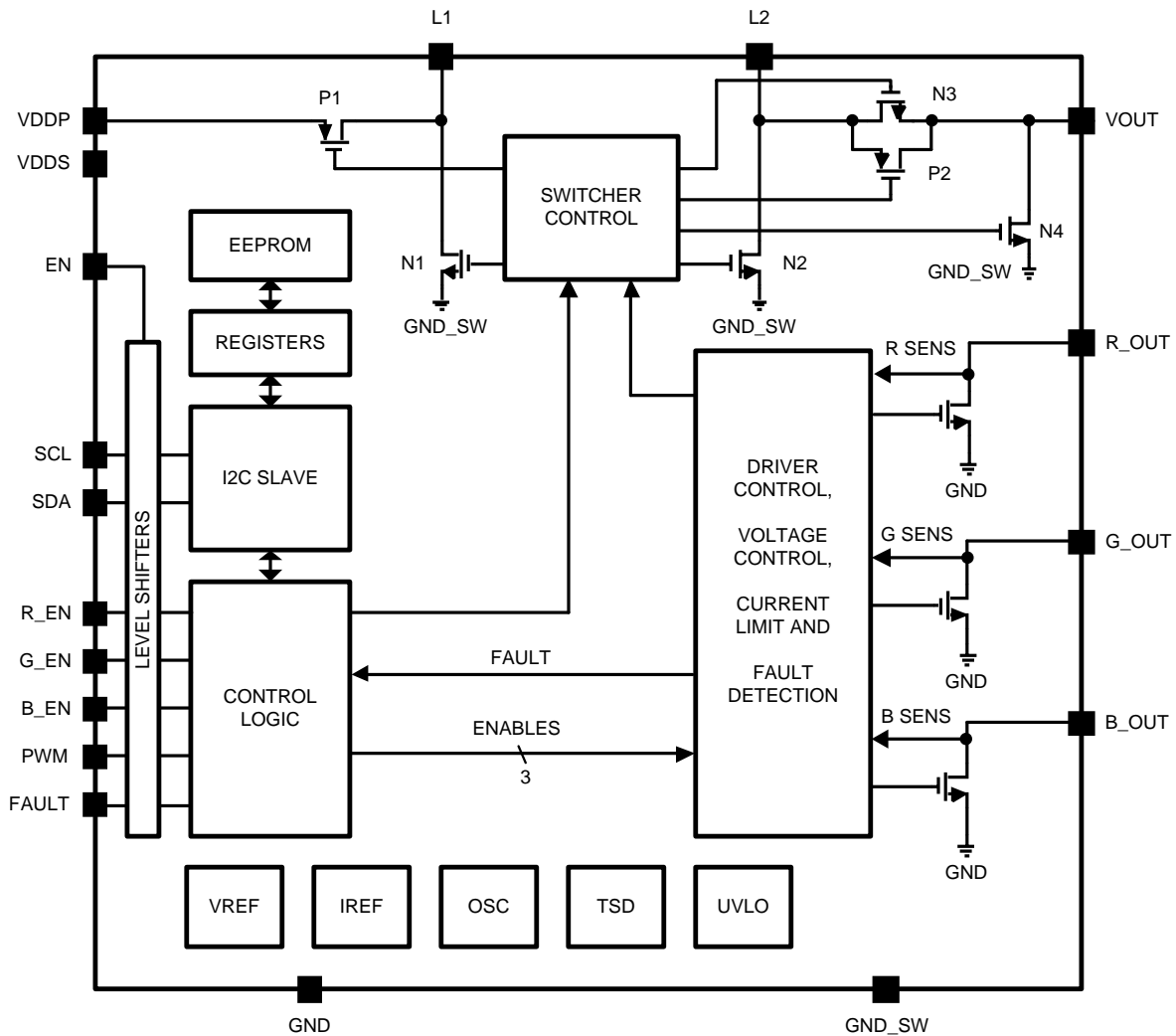
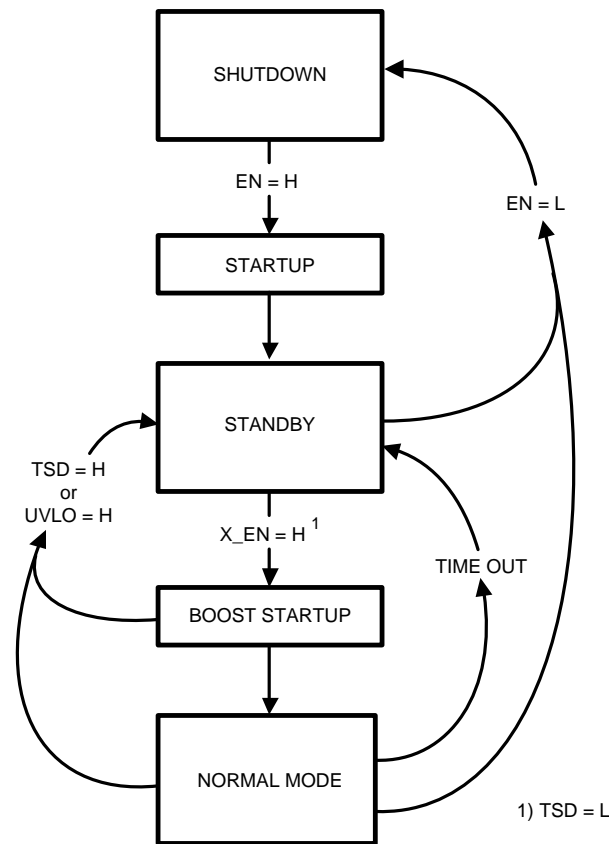

Figure 3. LM3549 Block Diagram

## Modes of Operation



**Figure 4. Modes of Operation**

**SHUTDOWN:** Shutdown mode is entered always if EN is low or internal Power On Reset (POR) is active. Power on reset will activate during the chip startup or when the supply voltage VDD falls below 1.5V. This is the low power consumption mode, when all circuit functions are disabled.

**STARTUP:** When EN input is pulled high, the internal startup sequence powers up all the needed internal blocks (VREF, Oscillator, etc.). EEPROM values are also read to registers during Startup.

**STANDBY:** After Startup device enters Standby mode. In standby mode all support blocks are active but buck-boost converter and the drivers are disabled. Control registers can be written in this mode and the control bits are effective immediately. EEPROM writing is allowed only in standby mode.

**BOOST STARTUP:** Soft start for boost output is generated in the boost startup mode. The boost output is raised in a low current mode. Soft start time can be set with registers. The boost startup is entered from Standby if any of the X\_EN inputs is pulled high.

**NORMAL:** During normal mode user controls the chip using the X\_EN inputs. In normal mode buck-boost converter and drivers are active. Device returns to standby mode if all X\_EN inputs are low for time period set by Time out register. If EN input is pulled low device goes to shutdown mode.

**TSD:** If the chip temperature rises too high, the thermal shutdown (TSD) disables the chip operation and Standby mode is entered until no thermal shutdown event is present.

### Typical Performance Characteristics

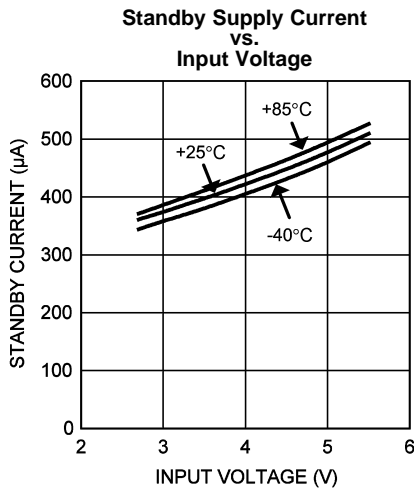

Figure 5.

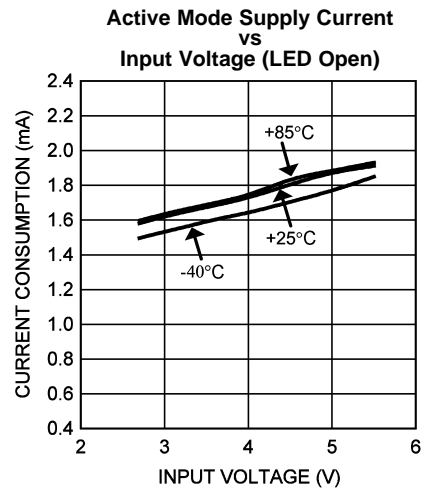

Figure 6.

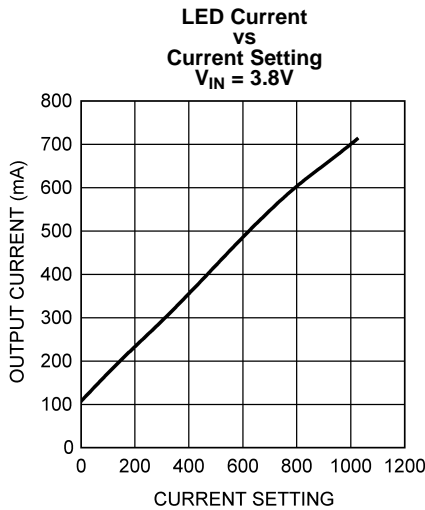

Figure 7.

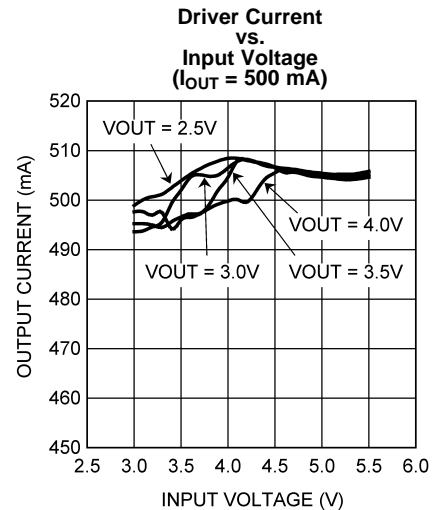

Figure 8.

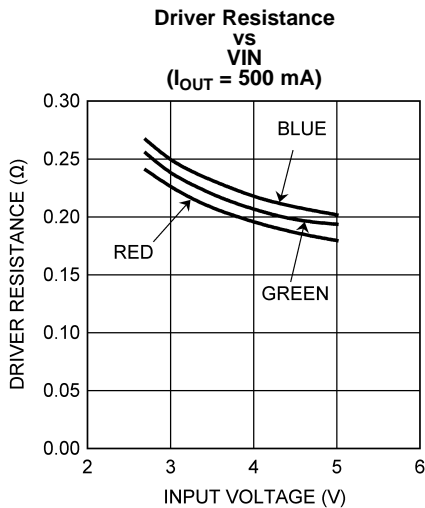

Figure 9.

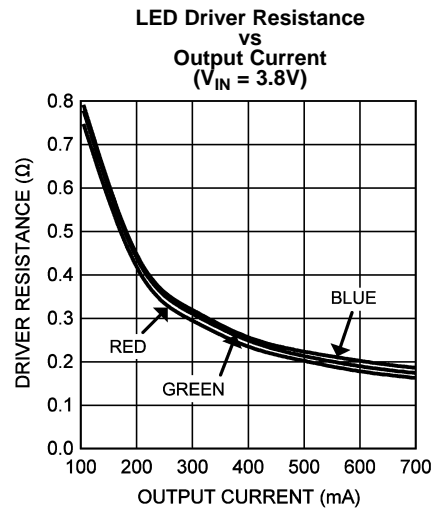

Figure 10.

**Typical Performance Characteristics (continued)**

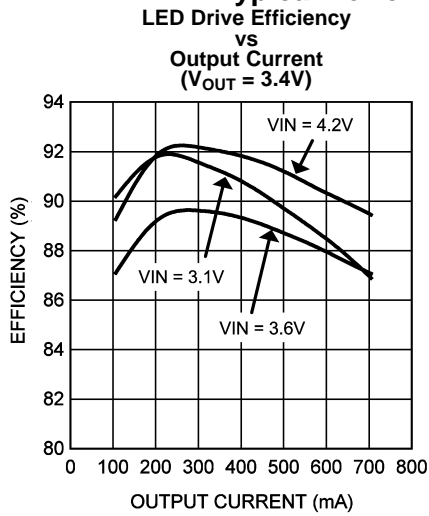

Figure 11.

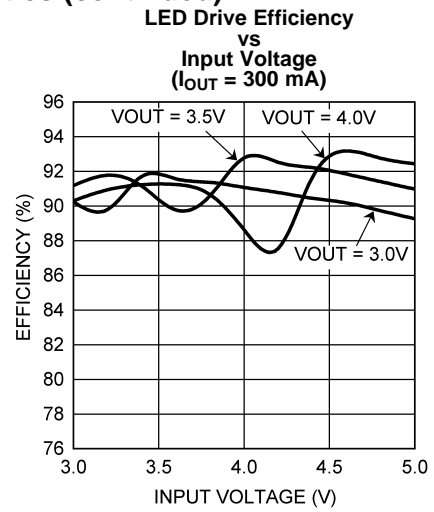

Figure 12.

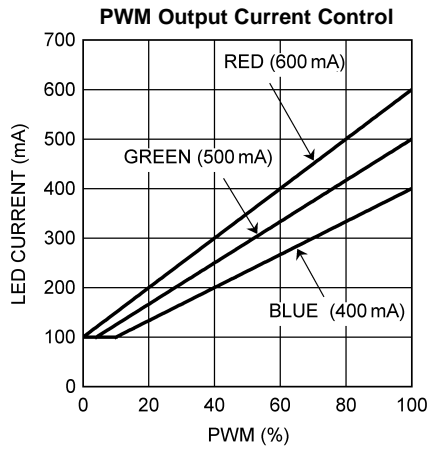

Figure 13.

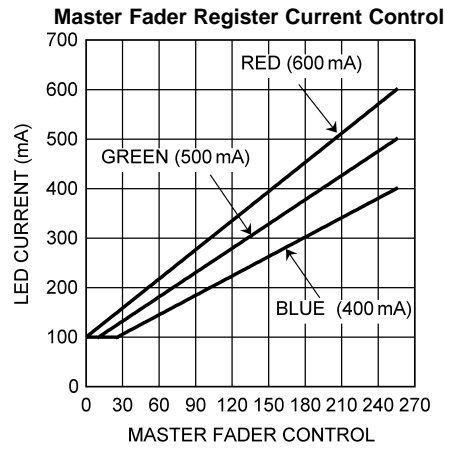

Figure 14.

## OPERATION DESCRIPTION

LM3549 is a sequential LED driver for portable video projectors. It has three high current low side drivers and a buck-boost DC-DC converter. Only single LED can be enabled at any given time. DC-DC converter quickly adjusts the output voltage to a suitable level based on each LED's forward voltage. This minimizes the power dissipation at the drivers and maximizes the system efficiency.

Figure 15 shows a typical timing of a portable video projector light source. Each frame is divided into 10 individual color sequences. White balance is achieved by adjusting the driver currents.

Timing of LM3549 depends solely on the R\_EN, G\_EN and B\_EN inputs. Each driver's current is set with I<sup>2</sup>C registers and current levels can be stored to internal EEPROM. After correct current values are stored to EEPROM LM3549 can be used in application without I<sup>2</sup>C interface.

Full frame	1/60Hz	16.66 ms
Red	Full frame x 7.5%	1.25 ms
Green	Full frame x 11%	1.822 ms
Blue	Full frame x 12.5%	2.08 ms

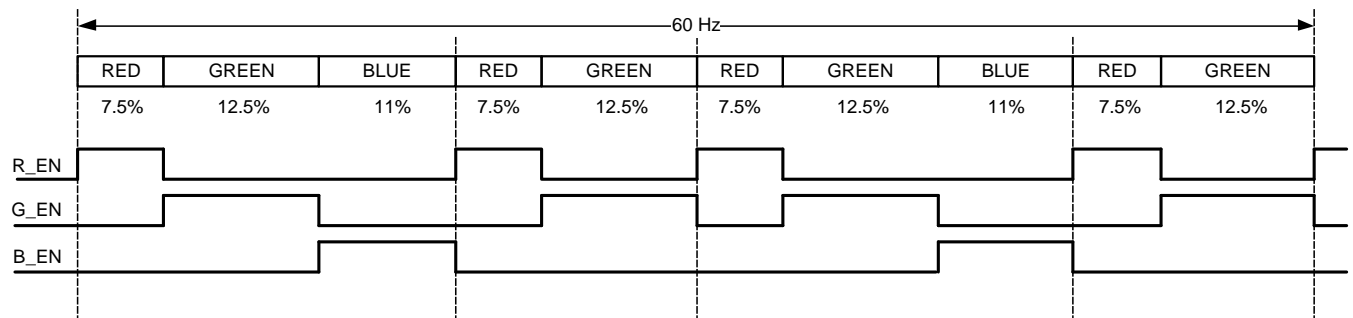

Figure 15. Timing Chart

## CONTROL INTERFACE

Even though each driver has its own control input only one driver can be enabled at any given time. If second control is pulled high while previous color is active second output won't be enabled until the first input is pulled low. This can be seen on Figure 16. G\_EN is pulled high while R\_EN is still high. G\_OUT is not activated until R\_EN is pulled low. Next B\_EN and R\_EN are both pulled high while G\_EN is high. When G\_EN is pulled low R\_OUT is enabled because R\_EN has higher priority (Priority order: RGB).

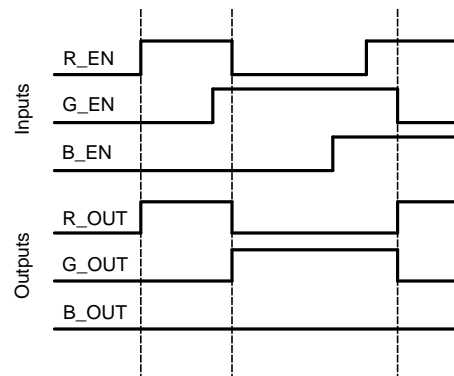
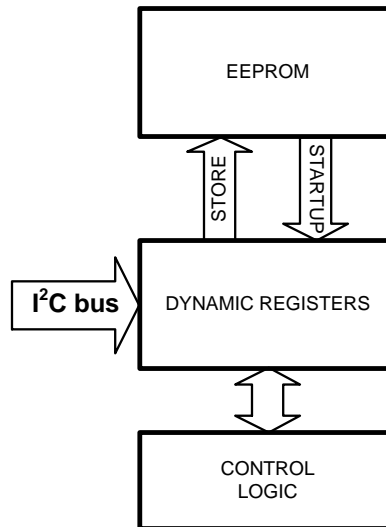

Figure 16. Control Signals

## CONTROL REGISTERS

Figure 17 shows the structure of the control registers. Control registers consists of volatile dynamic registers and non volatile EEPROM.



**Figure 17. Register Structure**

All I<sup>2</sup>C register read write commands are done to volatile dynamic registers. Dynamic registers are also used to set the device parameters. All registers except FAULT and EEPROM CONTROL register can be stored to EEPROM. EEPROM values are automatically read to dynamic registers during startup. This makes device use very versatile. After calibration device can be used even without I<sup>2</sup>C control. If system has I<sup>2</sup>C bus, control registers can be written to adjust parameters on the fly. If registers need to be set back to default values this can be done by first writing 04h to register 40h (EE init bit to “1”) followed by 01h to register 40h (EE read bit to “1”).

## EEPROM PROGRAMMING

EEPROM values can be rewritten if device needs recalibration. This can be done for example if white point changes due to aging effect of the LEDs. To store current register values to EEPROM user needs to first write 04h to register 40h (EE init bit to “1”) followed by 02h to register 40h (EE prog bit to “1”). LM3549 Internal charge pump generates the high voltage required for programming the EEPROM. To be able to generate this high voltage  $V_{in}$  needs to be set to 5V during EEPROM programming. EEPROM programming should be completed within approximately 200 ms. Once EEPROM programming is completed LM3549 sets EE\_ready bit to 1. After this  $V_{in}$  voltage can be set back to normal operating level. EEPROM programming should always be done in standby mode.

## CURRENT SETTING

There are three 10 bit current settings for each driver. 10 bits are divided into two eight bit registers. First register holds the eight least significant bits (LSB) and the second register holds the two most significant bits (MSB). These settings are grouped into three banks. IR0, IG0 and IB0 form a bank0; IR1, IG1 and IB1 form a bank1 and IR2, IG2 and IB2 form a bank2. For example IR0\_MSB holds the two MSB for red on bank0 and IR0\_LSB the eight LSB for red on bank0. Bank is selected with BANK\_SEL register (00 = bank0, 01 = bank1 and 10 or 11 = bank2).

Current setting is linear up to 550mA output current (see figure LED Current vs Current Setting in [Typical Performance Characteristics](#)). 550mA current is achieved with current setting  $I_{SET} = 710$ . After this the current step decreases slightly. For currents up to 550 mA current setting can be calculated using formula:

$$I_{SET} = (\text{target current in mA} - 100 \text{ mA}) / (650\text{mA}/1024)$$

For currents between 550mA and 700mA current setting can be calculated using formula:

$$I_{SET} = (\text{target current in mA} - 550 \text{ mA}) / 0.479 \text{ mA} + 710$$

## BRIGHTNESS CONTROL

Output current of all drivers can be adjusted using PWM input or FADER register. This can be used to easily adjust the total brightness of the LEDs. Brightness control function can be enabled from the CTRL register as seen in table below. In case of PWM input brightness control (BRC) is the positive duty cycle of the input signal. In case of FADER register brightness is MASTER FADER[7:0]/255.

MFE	PWM	Brightness Control
0	0	No brightness control
0	1	PWM input
1	0	FADER register
1	1	PWM input

The maximum currents of the drivers are set in the current setting registers. Brightness control keeps the ratio of the driver currents constant and adjusts the output currents based on the highest current setting. Driver currents can be adjusted between 100 mA to the maximum current set in the registers (see figures PWM Output Current Control and Master Fader Register Current Control in [Typical Performance Characteristics](#)).

$I_{SET1}$  =highest current setting

$I_{SET2}$  =current setting 2

$I_{SET3}$  =current setting 3

$R1$  =  $(I_{SET2}/I_{SET1})$ , ratio of current 2 and the highest current

$R2$  =  $(I_{SET3}/I_{SET1})$ , ratio of current 3 and the highest current

**BRC** =brightness control

$I1 = I_{SET1} \times BRC$

$I2 = I1 \times R1$

$I3 = I1 \times R2$

## PWM TIMING

[Figure 18](#) shows example of PWM brightness control. PWM input can be change at any given time but control takes effect when next enable is pulled high. To ensure that control takes effect for the next color time from PWM change to next enable needs to be greater than timeout time (300  $\mu$ s typical).

At the beginning of the example frame PWM input is changed from 100% to 80% while green driver is enabled. Brightness level is not changed in the middle of the green frame but at the beginning of the next color which in this example is blue. During next green PWM is set back to 100%. This is done at least 300  $\mu$ s before next enable is pulled high and control takes effect then. During next green PWM is changed to 0%. Time from PWM change to next enable (blue) is less than 300  $\mu$ s and control don't take effect when blue starts but one color later, what in this example is red.

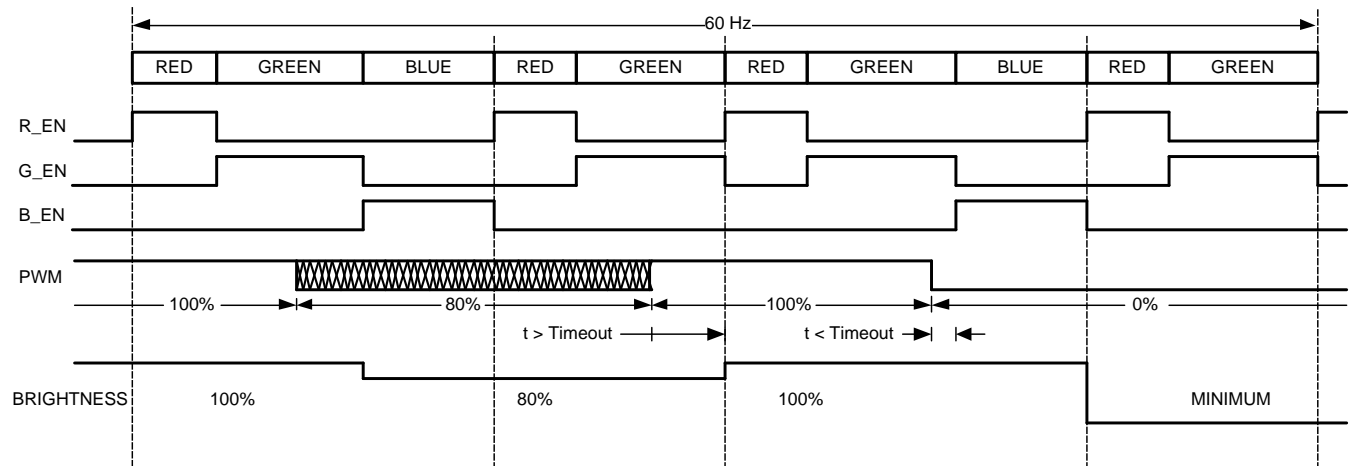

**Figure 18. PWM Timing**

## FAULT DETECTION

LM3549 can detect several different fault conditions. These are LED open, LED short, thermal shutdown (TSD), under voltage lockout (UVLO) and buck-boost converter over current protection (OCP). If any of the fault conditions occur corresponding fault bit is set in the fault register. If fault mask bit is not set also Fault output is pulled low. Reading Fault register resets its value to zero and sets Fault output to high impedance state.

## LED OPEN FAULT

Open fault is generated when at the end of color  $V_{OUT}$  is at maximum and no current is flowing through driver ( $V_{Dx} = 0V$ ). Also OCP fault needs to be low. Open fault can be generated by broken LED or a soldering defect.

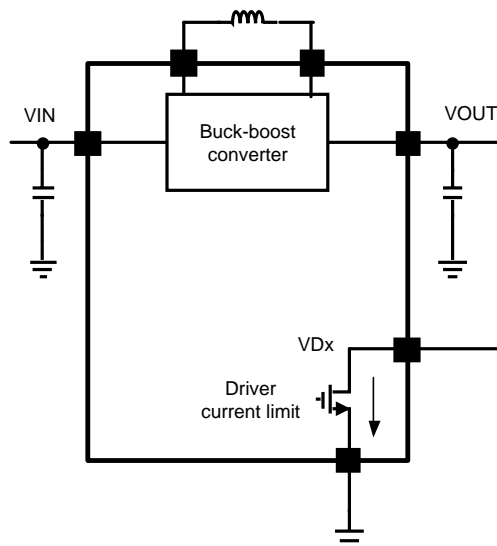

**Figure 19. LED Open Fault**

## LED SHORT FAULT

Short fault is detected when  $V_{OUT} < 1.0V$  at the end of a color. Short fault is generated when  $V_{OUT}$  is shorted to driver by soldering defect or faulty LED. Driver current limit limits the maximum current. Depending on output current and positive limit settings, LED short can also generate OCP fault to fault register.

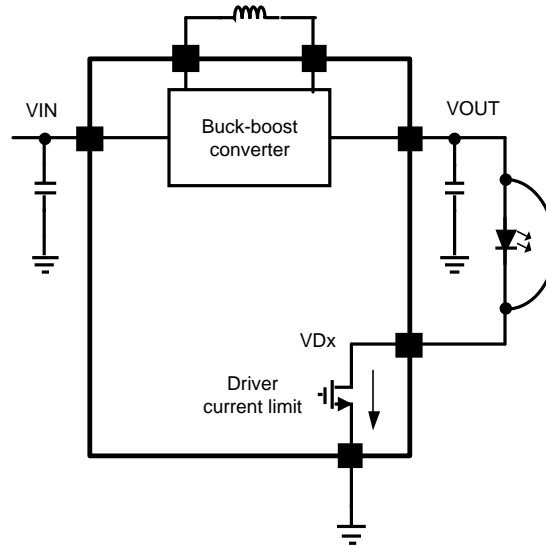

Figure 20. LED Short Fault

## TSD FAULT

Thermal shutdown (TSD) fault is generated if junction temperature rises above TSD level. TSD engages at  $T_J = 150^\circ C$  (typ) and disengages at  $T_J = 140^\circ C$  (typ). TSD sets device to standby mode. Occasionally a false TSD fault is generated to Fault register when device goes from shutdown mode to standby mode. It is good practice to reset the fault register by reading it every time after device is set from shutdown mode to standby mode.

## UVLO FAULT

Under voltage lock out (UVLO) fault is generated if  $V_{IN}$  drops below UVLO level ( $\sim 2.5V$ ). UVLO sets device to standby mode. When  $V_{IN}$  rises back above the 2.5V device exits UVLO. If control register values were changed from EEPROM defaults they need to be rewritten to registers because UVLO condition can generate EEPROM read sequence.

## OVER CURRENT PROTECTION FAULT

Over current protection (OCP) fault is generated when positive current limit is active at the end of a color. It is important to notice that OCP fault is not always set when positive current limit is activated. Positive current limit can activate during normal operation when buck-boost is adjusting the output voltage to a higher level. OCP can be caused by short from  $V_{OUT}$  to GND, short from driver to GND or if too low positive current limit value is set for desired output current.

## I<sup>2</sup>C Compatible Interface

### I<sup>2</sup>C ADDRESS

LM3549 I<sup>2</sup>C address is 36 hex (7 bits).

### I<sup>2</sup>C SIGNALS

The SCL pin is used for the I<sup>2</sup>C clock and the SDA pin is used for bidirectional data transfer. Both these signals need a pull-up resistor according to I<sup>2</sup>C specification. The values of the pull-up resistors are determined by the capacitance of the bus (typ.  $\sim 1.8k$ ). Signal timing specifications are shown in [Table 1](#).

**I<sup>2</sup>C VALIDITY**

The data on SDA line must be stable during the HIGH period of the clock signal (SCL). In other words, state of the data line can only be changed when CLK is LOW.

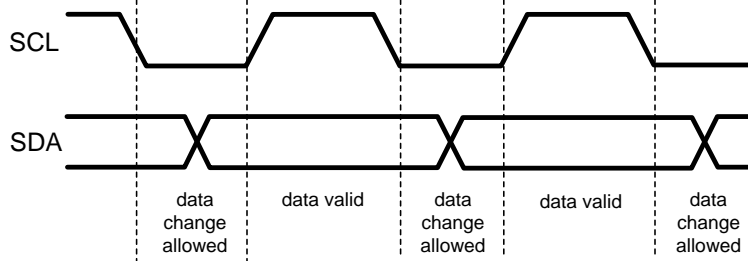

**Figure 21. I<sup>2</sup>C Signals: Data Validity**

**I<sup>2</sup>C START AND STOP CONDITIONS**

START and STOP bits classify the beginning and the end of the I<sup>2</sup>C session. START condition is defined as SDA signal transitioning from HIGH to LOW while SCL line is HIGH. STOP condition is defined as the SDA transitioning from LOW to HIGH while SCL is HIGH. The I<sup>2</sup>C master always generates START and STOP bits. The I<sup>2</sup>C bus is considered to be busy after START condition and free after STOP condition. During data transmission, I<sup>2</sup>C master can generate repeated START conditions. First START and repeated START conditions are equivalent, function-wise.

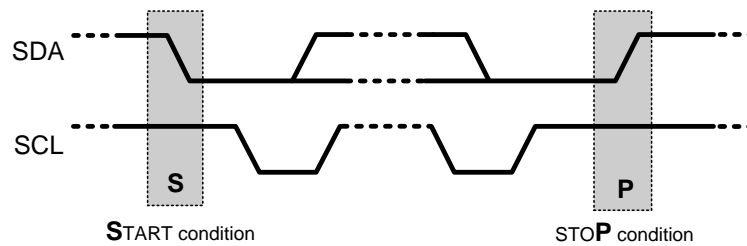
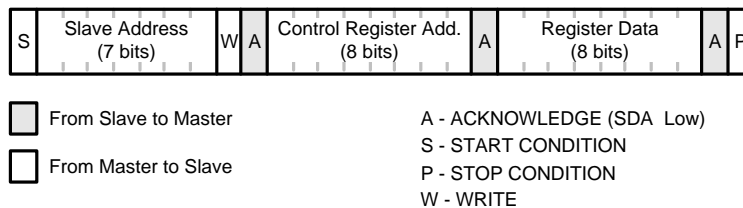

**Figure 22. Start and Stop Conditions**

**TRANSFERRING DATA**

Every byte put on the SDA line must be eight bits long, with the most significant bit (MSB) being transferred first. Each byte of data has to be followed by an acknowledge bit. The acknowledge related clock pulse is generated by the master. The transmitter releases the SDA line (HIGH) during the acknowledge clock pulse. The receiver must pull down the SDA line during the ninth clock pulse, signifying an acknowledge. A receiver which has been addressed must generate an acknowledge after each byte has been received.

After the START condition, the I<sup>2</sup>C master sends a chip address. This address is seven bits long followed by an eighth bit which is a data direction bit (R/W). The LM3549 address is 36 hex. For the eighth bit, a “0” indicates a WRITE and a “1” indicates a READ. The second byte selects the register to which the data will be written. The third byte contains data to write to the selected register.



**Figure 23. I<sup>2</sup>C Write Cycle**

When a READ function is to be accomplished, a WRITE function must precede the READ function, as shown in Figure 24

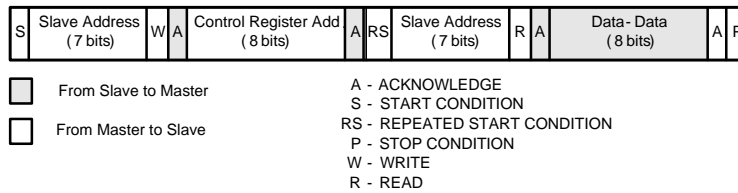

Figure 24. I<sup>2</sup>C Read Cycle

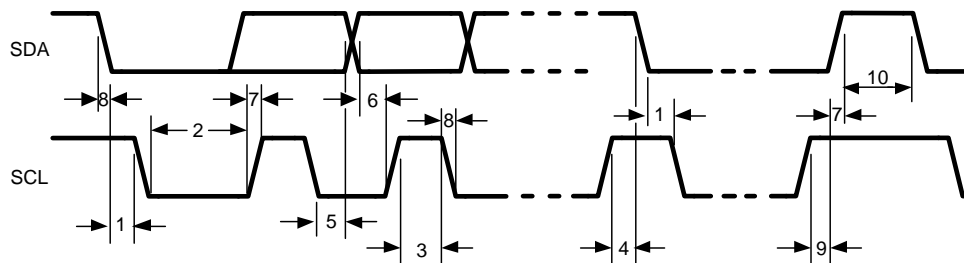

Figure 25. I<sup>2</sup>C Timing Diagram

Table 1. I<sup>2</sup>C Timing Parameters

Symbol	Parameter	Limit		Units
		Min	Max	
1	Hold Time (repeated) START Condition	0.6		µs
2	Clock Low Time	1.3		µs
3	Clock High Time	600		ns
4	Setup Time for a Repeated START Condition	600		ns
5	Data Hold	300	900	ns
5	Data Hold Time (input direction)	0	900	ns
6	Data Setup Time	100		ns
7	Rise Time of SDA and SCL	20 + 0.1Cb	300	ns
8	Fall Time of SDA and SCL	15 + 0.1Cb	300	ns
9	Set-up Time for STOP condition	600		ns
10	Bus Free Time between a STOP and a START Condition	1.3		µs
Cb	Capacitive Load for Each Bus Line	10	200	pF

Register Map

ADDR	NAME	D7	D6	D5	D4	D3	D2	D1	D0	DEFAULT	NOTE
00H	BANK_SEL							Bank_sel[1:0]		00H	EEPROM
01H	IR0_LSB	Red 0 [7:0]								81H	EEPROM
02H	IR0_MSB	N/A						Red 0 [9:8]		01H	EEPROM
03H	IG0_LSB	Green 0 [7:0]								81H	EEPROM
04H	IG0_MSB	N/A						Green 0 [9:8]		01H	EEPROM
05H	IB0_LSB	Blue 0 [7:0]								81H	EEPROM
06H	IB0_MSB	N/A						Blue 0 [9:8]		01H	EEPROM
07H	IR1_LSB	Red 1 [7:0]								E7H	EEPROM
08H	IR1_MSB	N/A						Red 1 [9:8]		00H	EEPROM

ADDR	NAME	D7	D6	D5	D4	D3	D2	D1	D0	DEFAULT	NOTE
09H	IG1_LSB	Green 1 [7:0]								E7H	EEPROM
0AH	IG1_MSB	N/A					Green 1 [9:8]			00H	EEPROM
0BH	IB1_LSB	Blue 1 [7:0]								E7H	EEPROM
0CH	IB1_MSB	N/A					Blue 1 [9:8]			00H	EEPROM
0DH	IR2_LSB	Red 2 [7:0]								4DH	EEPROM
0EH	IR2_MSB	N/A					Red 2 [9:8]			00H	EEPROM
0FH	IG2_LSB	Green 2 [7:0]								4DH	EEPROM
10H	IG2_MSB	N/A					Green 2 [9:8]			00H	EEPROM
11H	IB2_LSB	Blue 2 [7:0]								4DH	EEPROM
12H	IB2_MSB	N/A					Blue 2 [9:8]			00H	EEPROM
13H	FADER	MASTER FADER [7:0]								FFH	EEPROM
14H	CTRL	N/A	SOFT START[1:0]			TIME OUT[1:0]		MFE	PWM	00H	EEPROM
15H	ILIMIT	N/A	POS_LIMIT[1:0]		N/A			NEG_LIMIT[1:0]		11H	EEPROM
16H	F_MASK	N/A			SHORT	OPEN	UVLO	TSD	OCP	00H	EEPROM
17H	FAULT	N/A	SHORT[1:0]		OPEN[1:0]		UVLO	TSD	OCP	00H	Read Only
19H	USR1	User Register1[7:0]								00H	EEPROM
1AH	USR2	User Register2[7:0]								00H	EEPROM
40H	EEPROM CONTROL	EE ready					EE init	EE prog	EE read	00H	R/W

## I<sup>2</sup>C Register Details

### 00h BANK\_SEL[1:0]

Bank selection register. Selects one of the three current setting banks.

BIT		BANK SELECTION
0	0	Bank 0
0	1	Bank 1
1	0	Bank 2
1	1	Bank 2

### 01h IR0\_LSB and 02h IR0\_MSB

Red LED current setting for Bank 0. IR0\_LSB holds the eight least significant bits and IR0\_MSB the two most significant bits.

### 03h IG0\_LSB and 04h IG0\_MSB

Green LED current setting for Bank 0. IG0\_LSB holds the eight least significant bits and IG0\_MSB the two most significant bits.

### 05h IB0\_LSB and 06h IB0\_MSB

Blue LED current setting for Bank 0. IB0\_LSB holds the eight least significant bits and IB0\_MSB the two most significant bits.

### 07h IR1\_LSB and 08h IR1\_MSB

Red LED current setting for Bank 1. IR1\_LSB holds the eight least significant bits and IR1\_MSB the two most significant bits.

### 09h IG1\_LSB and 0Ah IG1\_MSB

Green LED current setting for Bank 1. IG1\_LSB holds the eight least significant bits and IG1\_MSB the two most significant bits.

**0Bh IB1\_LSB and 0Ch IB1\_MSB**

Blue LED current setting for Bank 1. IB1\_LSB holds the eight least significant bits and IB1\_MSB the two most significant bits.

**0Dh IR2\_LSB and 0Eh IR2\_MSB**

Red LED current setting for Bank 2. IR2\_LSB holds the eight least significant bits and IR2\_MSB the two most significant bits.

**0Fh IG2\_LSB and 10h IG2\_MSB**

Green LED current setting for Bank 2. IG2\_LSB holds the eight least significant bits and IG2\_MSB the two most significant bits.

**11h IB2\_LSB and 12h IB2\_MSB**

Blue LED current setting for Bank 2. IB2\_LSB holds the eight least significant bits and IB2\_MSB the two most significant bits.

**13h FADER**

Master fader control register. Can be used to control the total brightness of the LEDs if MFE is enabled.

**14h CTRL**

Control register. Controls many of the LM3549 features.

**BIT[1:0] PWM and MFE**

Control register bits [1:0] can be used to enable master control or PWM brightness control.

MFE	PWM	BRIGHTNESS CONTROL
0	0	No brightness control
0	1	PWM input
1	0	Master input
1	1	PWM input

**BIT[3:2] TIME OUT[1:0]**

Selects how long device stays in active mode after all x\_EN controls have been set low

BIT		TIME OUT
0	0	125 ms
0	1	250 ms
1	0	500 ms
1	1	1s

**BIT[5:4] SOFT START[1:0]**

Enables soft start feature and selects soft start time.

BIT		SOFT START TIME
0	0	disabled
0	1	0.5s
1	0	1s
1	1	2s

**15h ILIMIT**

ILIMIT register sets the buck-boost converters current limit values.

**BIT[1:0] NEG\_LIMIT[1:0]**

Selects buck-boost converters negative current limit.

BIT		NEGATIVE CURRENT LIMIT
0	0	550 mA
0	1	1100 mA
1	0	1650 mA
1	1	2200 mA

**BIT[5:4] POS\_LIMIT[1:0]**

Selects buck-boost converters positive current limit.

BIT		POSITIVE CURRENT LIMIT
0	0	500 mA
0	1	1000 mA
1	0	1500 mA
1	1	2000 mA

**16h F\_MASK**

Fault output mask register. Can be used to disable fault output from desired faults.

**17h FAULT**

Fault register. If fault occurs corresponding fault bits are set in fault register. Reading Fault register resets it. Read only register.

**BIT[0] OCP**

Over current protection. Buck-boost converters current limit has been reached.

**BIT[1] TSD**

Thermal shutdown fault. Junction temperature has risen above TSD level.

**BIT[2] UVLO**

Under voltage lock-out. Input voltage has fallen below UVLO threshold level.

**BIT[4:3] OPEN[1:0]**

LED open fault.

BIT		FAULT
0	0	No fault
0	1	Red open
1	0	Green open
1	1	Blue open

**BIT[6:5] SHORT[1:0]**

LED short fault.

BIT		FAULT
0	0	No fault
0	1	Red short
1	0	Green short
1	1	Blue short

**19h and 1AH USR1 and USR2**

User registers 1 and 2. Can be used to store any user data. No affect on the device.

**40h EEPROM CONTROL**

EEPROM Control register. This register is used to program EEPROM. EEPROM programming is described in the EEPROM Programming chapter.

**Table 2. Recommended External Components**

Symbol	Symbol Explanation	Value	Type	Example
CIN	Input Capacitor	10 $\mu$ F, 6.3V/10V	X7R	
COU	Output Capacitor	4.7 $\mu$ F, 6.3V/10V	X7R	
L1	Switcher Inductor	2.2 $\mu$ H, 1900 mA		TDK VLF4014ST-2R2M1R9

### REVISION HISTORY

Changes from Original (May 2013) to Revision A	Page
• Changed layout of National Data Sheet to TI format .....	<a href="#">19</a>

**PACKAGING INFORMATION**

Orderable Device	Status (1)	Package Type	Package Drawing	Pins	Package Qty	Eco Plan (2)	Lead/Ball Finish (6)	MSL Peak Temp (3)	Op Temp (°C)	Device Marking (4/5)	Samples
LM3549SQ/NOPB	ACTIVE	WQFN	RTW	24	1000	Green (RoHS & no Sb/Br)	CU SN	Level-1-260C-UNLIM	-30 to 85	L3549SQ	<a href="#">Samples</a>
LM3549SQE/NOPB	ACTIVE	WQFN	RTW	24	250	Green (RoHS & no Sb/Br)	CU SN	Level-1-260C-UNLIM	-30 to 85	L3549SQ	<a href="#">Samples</a>
LM3549SQX/NOPB	ACTIVE	WQFN	RTW	24	4500	Green (RoHS & no Sb/Br)	CU SN	Level-1-260C-UNLIM	-30 to 85	L3549SQ	<a href="#">Samples</a>

(1) The marketing status values are defined as follows:

**ACTIVE:** Product device recommended for new designs.

**LIFEBUY:** TI has announced that the device will be discontinued, and a lifetime-buy period is in effect.

**NRND:** Not recommended for new designs. Device is in production to support existing customers, but TI does not recommend using this part in a new design.

**PREVIEW:** Device has been announced but is not in production. Samples may or may not be available.

**OBsolete:** TI has discontinued the production of the device.

(2) Eco Plan - The planned eco-friendly classification: Pb-Free (RoHS), Pb-Free (RoHS Exempt), or Green (RoHS & no Sb/Br) - please check <http://www.ti.com/productcontent> for the latest availability information and additional product content details.

**TBD:** The Pb-Free/Green conversion plan has not been defined.

**Pb-Free (RoHS):** TI's terms "Lead-Free" or "Pb-Free" mean semiconductor products that are compatible with the current RoHS requirements for all 6 substances, including the requirement that lead not exceed 0.1% by weight in homogeneous materials. Where designed to be soldered at high temperatures, TI Pb-Free products are suitable for use in specified lead-free processes.

**Pb-Free (RoHS Exempt):** This component has a RoHS exemption for either 1) lead-based flip-chip solder bumps used between the die and package, or 2) lead-based die adhesive used between the die and leadframe. The component is otherwise considered Pb-Free (RoHS compatible) as defined above.

**Green (RoHS & no Sb/Br):** TI defines "Green" to mean Pb-Free (RoHS compatible), and free of Bromine (Br) and Antimony (Sb) based flame retardants (Br or Sb do not exceed 0.1% by weight in homogeneous material)

(3) MSL, Peak Temp. - The Moisture Sensitivity Level rating according to the JEDEC industry standard classifications, and peak solder temperature.

(4) There may be additional marking, which relates to the logo, the lot trace code information, or the environmental category on the device.

(5) Multiple Device Markings will be inside parentheses. Only one Device Marking contained in parentheses and separated by a "~" will appear on a device. If a line is indented then it is a continuation of the previous line and the two combined represent the entire Device Marking for that device.

(6) Lead/Ball Finish - Orderable Devices may have multiple material finish options. Finish options are separated by a vertical ruled line. Lead/Ball Finish values may wrap to two lines if the finish value exceeds the maximum column width.

**Important Information and Disclaimer:** The information provided on this page represents TI's knowledge and belief as of the date that it is provided. TI bases its knowledge and belief on information provided by third parties, and makes no representation or warranty as to the accuracy of such information. Efforts are underway to better integrate information from third parties. TI has taken and

continues to take reasonable steps to provide representative and accurate information but may not have conducted destructive testing or chemical analysis on incoming materials and chemicals. TI and TI suppliers consider certain information to be proprietary, and thus CAS numbers and other limited information may not be available for release.

In no event shall TI's liability arising out of such information exceed the total purchase price of the TI part(s) at issue in this document sold by TI to Customer on an annual basis.

**TAPE AND REEL INFORMATION**

**QUADRANT ASSIGNMENTS FOR PIN 1 ORIENTATION IN TAPE**

\*All dimensions are nominal

Device	Package Type	Package Drawing	Pins	SPQ	Reel Diameter (mm)	Reel Width W1 (mm)	A0 (mm)	B0 (mm)	K0 (mm)	P1 (mm)	W (mm)	Pin1 Quadrant
LM3549SQ/NOPB	WQFN	RTW	24	1000	178.0	12.4	4.3	4.3	1.3	8.0	12.0	Q1
LM3549SQE/NOPB	WQFN	RTW	24	250	178.0	12.4	4.3	4.3	1.3	8.0	12.0	Q1
LM3549SQX/NOPB	WQFN	RTW	24	4500	330.0	12.4	4.3	4.3	1.3	8.0	12.0	Q1

**TAPE AND REEL BOX DIMENSIONS**

\*All dimensions are nominal

Device	Package Type	Package Drawing	Pins	SPQ	Length (mm)	Width (mm)	Height (mm)
LM3549SQ/NOPB	WQFN	RTW	24	1000	210.0	185.0	35.0
LM3549SQE/NOPB	WQFN	RTW	24	250	210.0	185.0	35.0
LM3549SQX/NOPB	WQFN	RTW	24	4500	367.0	367.0	35.0

RTW0024A

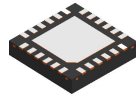

PACKAGE OUTLINE

WQFN - 0.8 mm max height

PLASTIC QUAD FLATPACK - NO LEAD

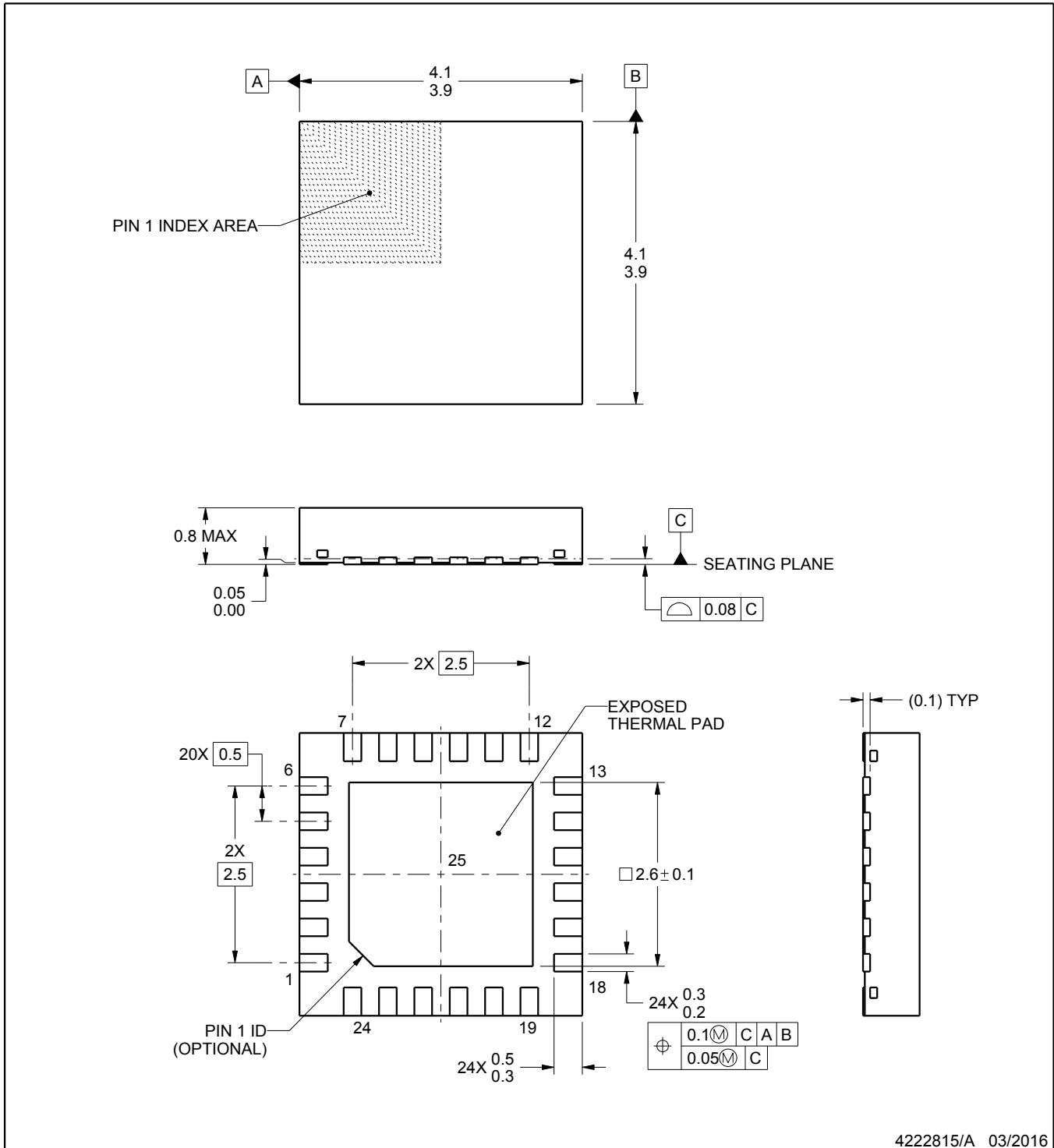

4222815/A 03/2016

NOTES:

1. All linear dimensions are in millimeters. Any dimensions in parenthesis are for reference only. Dimensioning and tolerancing per ASME Y14.5M.
2. This drawing is subject to change without notice.
3. The package thermal pad must be soldered to the printed circuit board for thermal and mechanical performance.

# EXAMPLE BOARD LAYOUT

RTW0024A

WQFN - 0.8 mm max height

PLASTIC QUAD FLATPACK - NO LEAD

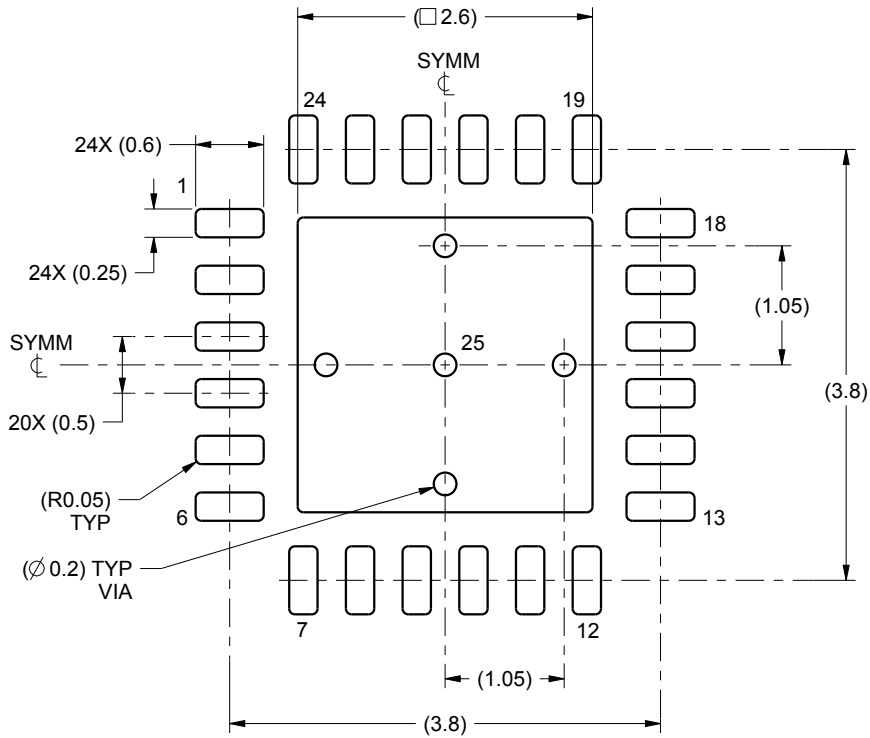

LAND PATTERN EXAMPLE  
SCALE:15X

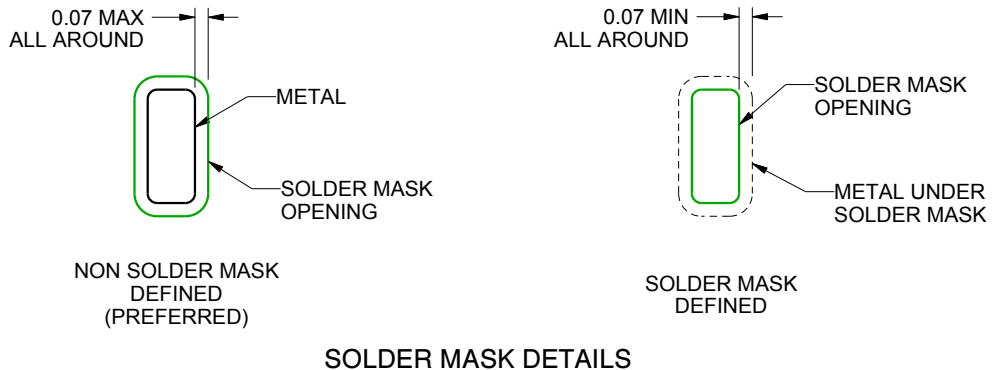

SOLDER MASK DETAILS

4222815/A 03/2016

NOTES: (continued)

4. This package is designed to be soldered to a thermal pad on the board. For more information, see Texas Instruments literature number SLUA271 ([www.ti.com/lit/sluea271](http://www.ti.com/lit/sluea271)).

# EXAMPLE STENCIL DESIGN

RTW0024A

WQFN - 0.8 mm max height

PLASTIC QUAD FLATPACK - NO LEAD

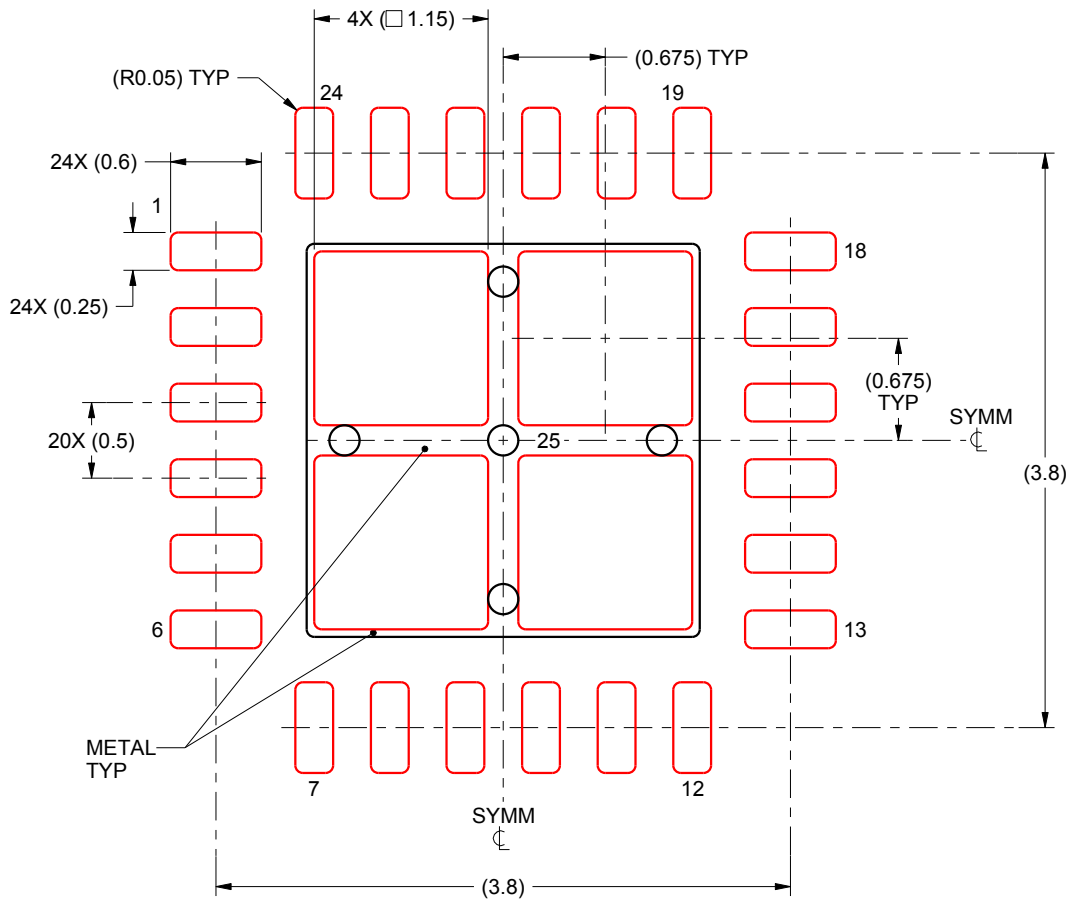

**SOLDER PASTE EXAMPLE**  
BASED ON 0.125 mm THICK STENCIL

EXPOSED PAD 25:  
78% PRINTED SOLDER COVERAGE BY AREA UNDER PACKAGE  
SCALE:20X

4222815/A 03/2016

NOTES: (continued)

5. Laser cutting apertures with trapezoidal walls and rounded corners may offer better paste release. IPC-7525 may have alternate design recommendations.

## IMPORTANT NOTICE

Texas Instruments Incorporated (TI) reserves the right to make corrections, enhancements, improvements and other changes to its semiconductor products and services per JESD46, latest issue, and to discontinue any product or service per JESD48, latest issue. Buyers should obtain the latest relevant information before placing orders and should verify that such information is current and complete.

TI's published terms of sale for semiconductor products (<http://www.ti.com/sc/docs/stdterms.htm>) apply to the sale of packaged integrated circuit products that TI has qualified and released to market. Additional terms may apply to the use or sale of other types of TI products and services.

Reproduction of significant portions of TI information in TI data sheets is permissible only if reproduction is without alteration and is accompanied by all associated warranties, conditions, limitations, and notices. TI is not responsible or liable for such reproduced documentation. Information of third parties may be subject to additional restrictions. Resale of TI products or services with statements different from or beyond the parameters stated by TI for that product or service voids all express and any implied warranties for the associated TI product or service and is an unfair and deceptive business practice. TI is not responsible or liable for any such statements.

Buyers and others who are developing systems that incorporate TI products (collectively, "Designers") understand and agree that Designers remain responsible for using their independent analysis, evaluation and judgment in designing their applications and that Designers have full and exclusive responsibility to assure the safety of Designers' applications and compliance of their applications (and of all TI products used in or for Designers' applications) with all applicable regulations, laws and other applicable requirements. Designer represents that, with respect to their applications, Designer has all the necessary expertise to create and implement safeguards that (1) anticipate dangerous consequences of failures, (2) monitor failures and their consequences, and (3) lessen the likelihood of failures that might cause harm and take appropriate actions. Designer agrees that prior to using or distributing any applications that include TI products, Designer will thoroughly test such applications and the functionality of such TI products as used in such applications.

TI's provision of technical, application or other design advice, quality characterization, reliability data or other services or information, including, but not limited to, reference designs and materials relating to evaluation modules, (collectively, "TI Resources") are intended to assist designers who are developing applications that incorporate TI products; by downloading, accessing or using TI Resources in any way, Designer (individually or, if Designer is acting on behalf of a company, Designer's company) agrees to use any particular TI Resource solely for this purpose and subject to the terms of this Notice.

TI's provision of TI Resources does not expand or otherwise alter TI's applicable published warranties or warranty disclaimers for TI products, and no additional obligations or liabilities arise from TI providing such TI Resources. TI reserves the right to make corrections, enhancements, improvements and other changes to its TI Resources. TI has not conducted any testing other than that specifically described in the published documentation for a particular TI Resource.

Designer is authorized to use, copy and modify any individual TI Resource only in connection with the development of applications that include the TI product(s) identified in such TI Resource. NO OTHER LICENSE, EXPRESS OR IMPLIED, BY ESTOPPEL OR OTHERWISE TO ANY OTHER TI INTELLECTUAL PROPERTY RIGHT, AND NO LICENSE TO ANY TECHNOLOGY OR INTELLECTUAL PROPERTY RIGHT OF TI OR ANY THIRD PARTY IS GRANTED HEREIN, including but not limited to any patent right, copyright, mask work right, or other intellectual property right relating to any combination, machine, or process in which TI products or services are used. Information regarding or referencing third-party products or services does not constitute a license to use such products or services, or a warranty or endorsement thereof. Use of TI Resources may require a license from a third party under the patents or other intellectual property of the third party, or a license from TI under the patents or other intellectual property of TI.

TI RESOURCES ARE PROVIDED "AS IS" AND WITH ALL FAULTS. TI DISCLAIMS ALL OTHER WARRANTIES OR REPRESENTATIONS, EXPRESS OR IMPLIED, REGARDING RESOURCES OR USE THEREOF, INCLUDING BUT NOT LIMITED TO ACCURACY OR COMPLETENESS, TITLE, ANY EPIDEMIC FAILURE WARRANTY AND ANY IMPLIED WARRANTIES OF MERCHANTABILITY, FITNESS FOR A PARTICULAR PURPOSE, AND NON-INFRINGEMENT OF ANY THIRD PARTY INTELLECTUAL PROPERTY RIGHTS. TI SHALL NOT BE LIABLE FOR AND SHALL NOT DEFEND OR INDEMNIFY DESIGNER AGAINST ANY CLAIM, INCLUDING BUT NOT LIMITED TO ANY INFRINGEMENT CLAIM THAT RELATES TO OR IS BASED ON ANY COMBINATION OF PRODUCTS EVEN IF DESCRIBED IN TI RESOURCES OR OTHERWISE. IN NO EVENT SHALL TI BE LIABLE FOR ANY ACTUAL, DIRECT, SPECIAL, COLLATERAL, INDIRECT, PUNITIVE, INCIDENTAL, CONSEQUENTIAL OR EXEMPLARY DAMAGES IN CONNECTION WITH OR ARISING OUT OF TI RESOURCES OR USE THEREOF, AND REGARDLESS OF WHETHER TI HAS BEEN ADVISED OF THE POSSIBILITY OF SUCH DAMAGES.

Unless TI has explicitly designated an individual product as meeting the requirements of a particular industry standard (e.g., ISO/TS 16949 and ISO 26262), TI is not responsible for any failure to meet such industry standard requirements.

Where TI specifically promotes products as facilitating functional safety or as compliant with industry functional safety standards, such products are intended to help enable customers to design and create their own applications that meet applicable functional safety standards and requirements. Using products in an application does not by itself establish any safety features in the application. Designers must ensure compliance with safety-related requirements and standards applicable to their applications. Designer may not use any TI products in life-critical medical equipment unless authorized officers of the parties have executed a special contract specifically governing such use. Life-critical medical equipment is medical equipment where failure of such equipment would cause serious bodily injury or death (e.g., life support, pacemakers, defibrillators, heart pumps, neurostimulators, and implantables). Such equipment includes, without limitation, all medical devices identified by the U.S. Food and Drug Administration as Class III devices and equivalent classifications outside the U.S.

TI may expressly designate certain products as completing a particular qualification (e.g., Q100, Military Grade, or Enhanced Product). Designers agree that it has the necessary expertise to select the product with the appropriate qualification designation for their applications and that proper product selection is at Designers' own risk. Designers are solely responsible for compliance with all legal and regulatory requirements in connection with such selection.

Designer will fully indemnify TI and its representatives against any damages, costs, losses, and/or liabilities arising out of Designer's non-compliance with the terms and provisions of this Notice.

## Looking for pricing, stock, or lifecycle information?

Click below to explore more details on WIN SOURCE:

 [View LM3549SQEV/NOPB on WIN SOURCE](#)

 [Texas Instruments](#) Information

## Optimize Your Supply Chain with WIN SOURCE Solutions

-  Global Sourcing Solution
-  Obsolete Management
-  Cost Control Management
-  Shortage Management
-  Alternative Solution
-  Excess Inventory Management