



THE DATASHEET OF LM2735XMYEVAL



Table of Contents

1 Features 1 2 Applications 1 3 Description 1 4 Revision History 2 5 Pin Configuration and Functions 3 6 Specifications 4 6.1 Absolute Maximum Ratings 4 6.2 ESD Ratings: LM2735 4 6.3 Recommended Operating Conditions 4 6.4 Thermal Information 4 6.5 Electrical Characteristics 5 6.6 Typical Characteristics 7 7 Detailed Description 9 7.1 Overview 9 7.2 Functional Block Diagram 11 7.3 Feature Description 11 7.4 Device Functional Modes 14	8 Application and Implementation 14 8.1 Application Information 14 8.2 Typical Applications 14 9 Power Supply Recommendations 37 10 Layout 37 10.1 Layout Guidelines 37 10.2 Layout Examples 38 10.3 Thermal Considerations 39 11 Device and Documentation Support 48 11.1 Device Support 48 11.2 Documentation Support 48 11.3 Community Resources 48 11.4 Trademarks 48 11.5 Electrostatic Discharge Caution 48 11.6 Glossary 49 12 Mechanical, Packaging, and Orderable Information 49
---	---

4 Revision History

NOTE: Page numbers for previous revisions may differ from page numbers in the current version.

Changes from Revision H (March 2018) to Revision I	Page
<ul style="list-style-type: none"> • Added bullet to Applications list regarding automotive device LM2735-Q1 1 	1
Changes from Revision G (August 2015) to Revision H	Page
<ul style="list-style-type: none"> • Changed V_{FB} Feedback Test Conditions from "$T_J = -40^{\circ}\text{C}$ to 125°C" To "$T_J = 0^{\circ}\text{C}$ to 125°C" for the SOT-23, WSON, and MSOP-PowerPAD devices 5 	5
Changes from Revision F (April 2013) to Revision G	Page
<ul style="list-style-type: none"> • Added <i>ESD Ratings</i> table, <i>Feature Description</i> section, <i>Device Functional Modes</i>, <i>Application and Implementation</i> section, <i>Power Supply Recommendations</i> section, <i>Layout</i> section, <i>Device and Documentation Support</i> section, and <i>Mechanical, Packaging, and Orderable Information</i> section. 1 	1
Changes from Revision E (April 2013) to Revision F	Page
<ul style="list-style-type: none"> • Changed layout of National Data Sheet to TI format 33 	33

5 Pin Configuration and Functions

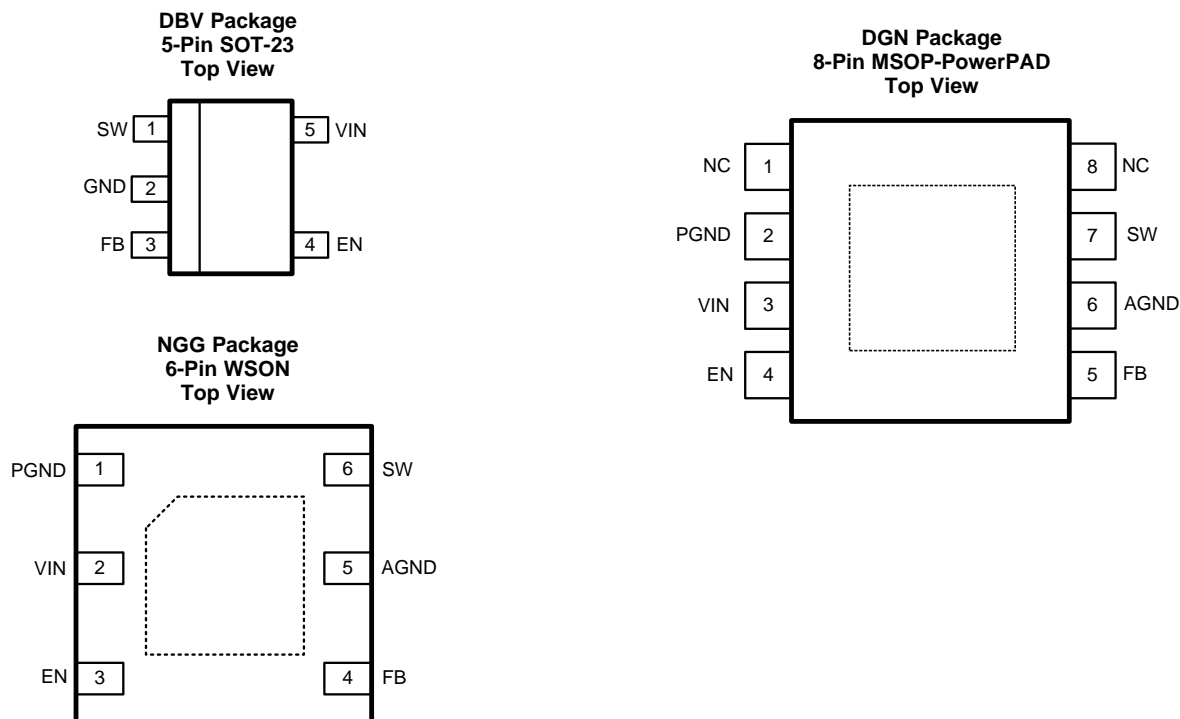

Pin Functions

NAME	PIN			I/O	DESCRIPTION
	SOT-23	WSON	MSOP-PowerPAD		
AGND	—	5	6	PWR	Signal ground pin. Place the bottom resistor of the feedback network as close as possible to this pin and pin 4. For MSOP-PowerPAD, place the bottom resistor of the feedback network as close as possible to this pin and pin 5
EN	4	3	4	I	Shutdown control input. Logic high enables operation. Do not allow this pin to float or be greater than $V_{IN} + 0.3\text{ V}$.
FB	3	4	5	I	Feedback pin. Connect FB to external resistor-divider to set output voltage.
GND	2	DAP	DAP	PWR	Signal and power ground pin. Place the bottom resistor of the feedback network as close as possible to this pin. For WSON, connect to pin 1 and pin 5 on top layer. Place 4-6 vias from DAP to bottom layer GND plane.
NC	—	—	1, 8	—	No Connect
PGND	—	1	2	PWR	Power ground pin. Place PGND and output capacitor GND close together.
SW	1	6	7	O	Output switch. Connect to the inductor, output diode.
VIN	5	2	3	PWR	Supply voltage for power stage, and input supply voltage.

6 Specifications

6.1 Absolute Maximum Ratings

 See⁽¹⁾

	MIN	MAX	UNIT
V_{IN}	-0.5	7	V
SW Voltage	-0.5	26.5	V
FB Voltage	-0.5	3	V
EN Voltage	-0.5	7	V
Junction temperature ⁽²⁾		150	°C
Soldering information, infrared/convection reflow (15 s)		220	°C
Storage Temperature	-65	150	°C

- (1) If Military/Aerospace specified devices are required, contact the Texas Instruments Sales Office/ Distributors for availability and specifications.
- (2) Thermal shutdown will occur if the junction temperature exceeds the maximum junction temperature of the device.

6.2 ESD Ratings: LM2735

			VALUE	UNIT
$V_{(ESD)}$	Electrostatic discharge	Human body model (HBM), per ANSI/ESDA/JEDEC JS-001 ⁽¹⁾⁽²⁾	±2000	V
		Charged device model (CDM), per JEDEC specification JESD22-C101 ⁽³⁾	±1000	

- (1) JEDEC document JEP155 states that 500-V HBM allows safe manufacturing with a standard ESD control process. Manufacturing with less than 500-V HBM is possible if necessary precautions are taken.
- (2) The human body model is a 100-pF capacitor discharged through a 1.5-k Ω resistor into each pin.
- (3) JEDEC document JEP157 states that 250-V CDM allows safe manufacturing with a standard ESD control process. Manufacturing with less than 250-V CDM is possible if necessary precautions are taken.

6.3 Recommended Operating Conditions

over operating free-air temperature range (unless otherwise noted)

		MIN	NOM	MAX	UNIT
V_{IN}		2.7		5.5	V
V_{SW}		3		24	V
V_{EN} ⁽¹⁾		0		V_{IN}	V
Junction Temperature Range		-40		125	°C
Power Dissipation	(Internal) SOT-23			400	mW

- (1) Do not allow this pin to float or be greater than $V_{IN} + 0.3$ V.

6.4 Thermal Information

THERMAL METRIC ⁽¹⁾		LM2735			UNIT
		NGG (WSON)	DBV (SOT-23)	DGN (MSOP-PowerPAD)	
		6 PINS	5 PINS	8 PINS	
$R_{\theta JA}$	Junction-to-ambient thermal resistance ⁽²⁾	54.9	164.2	59	°C/W
$R_{\theta JC(top)}$	Junction-to-case (top) thermal resistance ⁽²⁾	50.9	115.3	51.2	°C/W
$R_{\theta JB}$	Junction-to-board thermal resistance	29.3	27	35.8	°C/W
ψ_{JT}	Junction-to-top characterization parameter	0.7	12.8	2.7	°C/W
ψ_{JB}	Junction-to-board characterization parameter	29.4	26.5	35.6	°C/W
$R_{\theta JC(bot)}$	Junction-to-case (bottom) thermal resistance	9.3	N/A	7.3	°C/W

- (1) For more information about traditional and new thermal metrics, see the [Semiconductor and IC Package Thermal Metrics](#) application report.
- (2) Applies for packages soldered directly onto a 3" x 3" PC board with 2-oz. copper on 4 layers in still air.

6.5 Electrical Characteristics

Limits are for $T_J = 25^\circ\text{C}$. Minimum and Maximum limits are specified through test, design, or statistical correlation. Typical values represent the most likely parametric norm at $T_J = 25^\circ\text{C}$, and are provided for reference purposes only. $V_{IN} = 5\text{ V}$ unless otherwise indicated under the Conditions column.

PARAMETER	TEST CONDITIONS		MIN	TYP	MAX	UNIT
V_{FB}	Feedback Voltage	$-40^\circ\text{C} \leq T_J \leq 125^\circ\text{C}$ (SOT-23)	$T_J = 25^\circ\text{C}$	1.255		V
			$T_J = -40^\circ\text{C}$ to 125°C	1.23	1.28	
		$0^\circ\text{C} \leq T_J \leq 125^\circ\text{C}$ (SOT-23)	$T_J = 25^\circ\text{C}$	1.255		
			$T_J = 0^\circ\text{C}$ to 125°C	1.236	1.274	
		$-40^\circ\text{C} \leq T_J \leq 125^\circ\text{C}$ (WSON)	$T_J = 25^\circ\text{C}$	1.255		
			$T_J = -40^\circ\text{C}$ to 125°C	1.225	1.285	
		$0^\circ\text{C} \leq T_J \leq 125^\circ\text{C}$ (WSON)	$T_J = 25^\circ\text{C}$	1.255		
			$T_J = 0^\circ\text{C}$ to 125°C	1.229	1.281	
$-40^\circ\text{C} \leq T_J \leq 125^\circ\text{C}$ (MSOP-PowerPAD)	$T_J = 25^\circ\text{C}$	1.255				
	$T_J = -40^\circ\text{C}$ to 125°C	1.22	1.29			
$0^\circ\text{C} \leq T_J \leq 125^\circ\text{C}$ (MSOP-PowerPAD)	$T_J = 25^\circ\text{C}$	1.255				
	$T_J = 0^\circ\text{C}$ to 125°C	1.23	1.28			
$\Delta V_{FB}/V_{IN}$	Feedback Voltage Line Regulation	$V_{IN} = 2.7\text{ V}$ to 5.5 V		0.06		%/V
I_{FB}	Feedback Input Bias Current	$T_J = 25^\circ\text{C}$		0.1		μA
		$T_J = -40^\circ\text{C}$ to 125°C			1	
F_{SW}	Switching Frequency	LM2735-X	$T_J = 25^\circ\text{C}$	1600		kHz
			$T_J = -40^\circ\text{C}$ to 125°C	1200	2000	
		LM2735-Y	$T_J = 25^\circ\text{C}$	520		
			$T_J = -40^\circ\text{C}$ to 125°C	360	680	
D_{MAX}	Maximum Duty Cycle	LM2735-X	$T_J = 25^\circ\text{C}$	96%		
			$T_J = -40^\circ\text{C}$ to 125°C	88%		
		LM2735-Y	$T_J = 25^\circ\text{C}$	99%		
			$T_J = -40^\circ\text{C}$ to 125°C	91%		
D_{MIN}	Minimum Duty Cycle	LM2735-X		5%		
		LM2735-Y		2%		
$R_{DS(ON)}$	Switch ON-Resistance	SOT-23 and MSOP-PowerPAD	$T_J = 25^\circ\text{C}$	170		m Ω
			$T_J = -40^\circ\text{C}$ to 125°C		330	
		WSON	$T_J = 25^\circ\text{C}$	190		
			$T_J = -40^\circ\text{C}$ to 125°C		350	
I_{CL}	Switch Current Limit	$T_J = 25^\circ\text{C}$		3		A
		$T_J = -40^\circ\text{C}$ to 125°C		2.1		
SS	Soft Start			4		ms
I_Q	Quiescent Current (switching)	LM2735-X	$T_J = 25^\circ\text{C}$	7		mA
			$T_J = -40^\circ\text{C}$ to 125°C		11	
		LM2735-Y	$T_J = 25^\circ\text{C}$	3.4		
			$T_J = -40^\circ\text{C}$ to 125°C		7	
Quiescent Current (shutdown)	All Options $V_{EN} = 0\text{ V}$			80		nA
UVLO	Undervoltage Lockout	VIN Rising	$T_J = 25^\circ\text{C}$	2.3		V
			$T_J = -40^\circ\text{C}$ to 125°C		2.65	
		VIN Falling	$T_J = 25^\circ\text{C}$	1.9		
			$T_J = -40^\circ\text{C}$ to 125°C	1.7		

Electrical Characteristics (continued)

Limits are for $T_J = 25^\circ\text{C}$. Minimum and Maximum limits are specified through test, design, or statistical correlation. Typical values represent the most likely parametric norm at $T_J = 25^\circ\text{C}$, and are provided for reference purposes only. $V_{IN} = 5\text{ V}$ unless otherwise indicated under the Conditions column.

PARAMETER		TEST CONDITIONS	MIN	TYP	MAX	UNIT
V_{EN_TH}	Shutdown Threshold Voltage	See ⁽¹⁾ , $T_J = -40^\circ\text{C}$ to 125°C			0.4	V
	Enable Threshold Voltage	See ⁽¹⁾ , $T_J = -40^\circ\text{C}$ to 125°C	1.8			
I_{SW}	Switch Leakage	$V_{SW} = 24\text{ V}$		1		μA
I_{EN}	Enable Pin Current	Sink/Source		100		nA
T_{SD}	Thermal Shutdown Temperature ⁽²⁾			160		$^\circ\text{C}$
	Thermal Shutdown Hysteresis			10		

(1) Do not allow this pin to float or be greater than $V_{IN} + 0.3\text{ V}$.

(2) Thermal shutdown will occur if the junction temperature exceeds the maximum junction temperature of the device.

6.6 Typical Characteristics

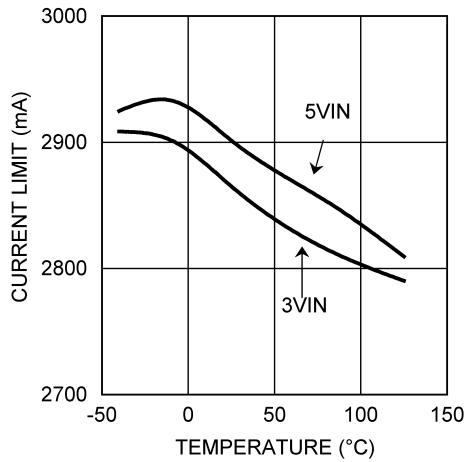

Figure 1. Current Limit vs Temperature

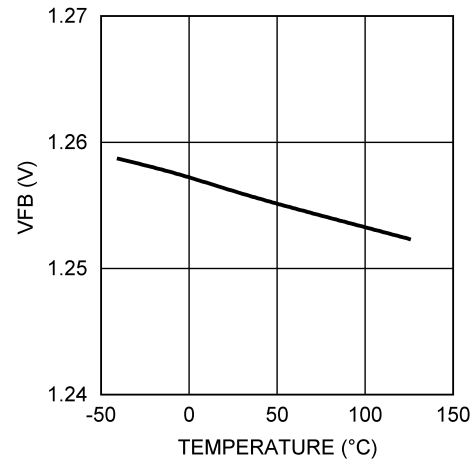

Figure 2. FB Pin Voltage vs Temperature

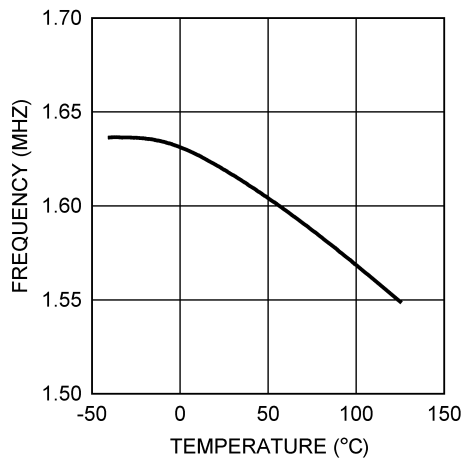

Figure 3. Oscillator Frequency vs Temperature - "X"

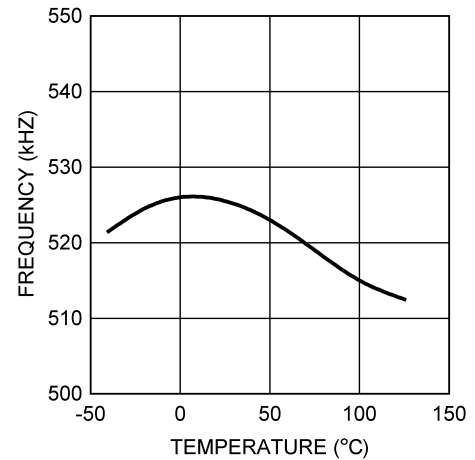

Figure 4. Oscillator Frequency vs Temperature - "Y"

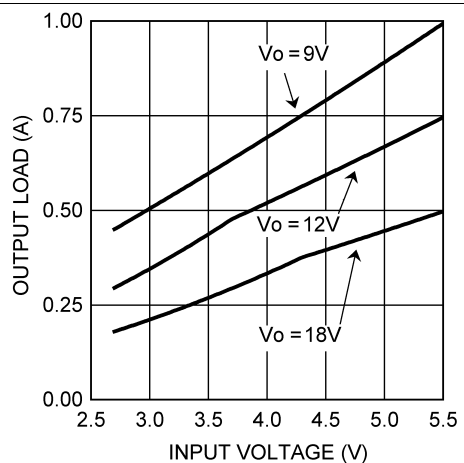

Figure 5. Typical Maximum Output Current vs V_{IN}

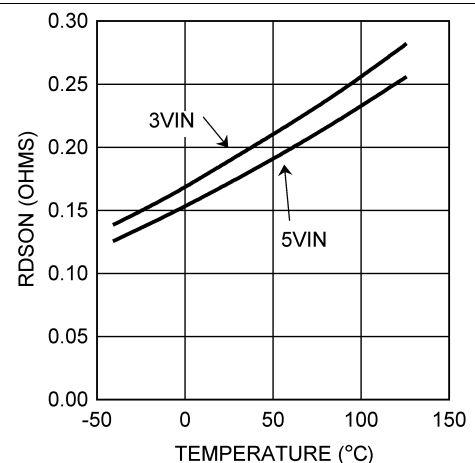
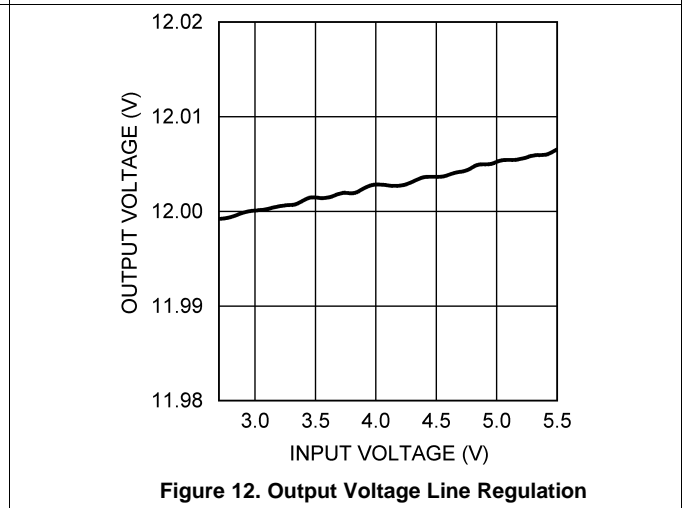
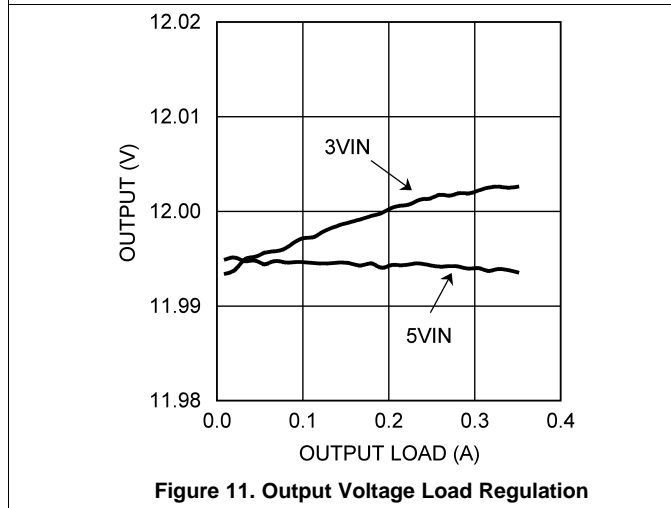
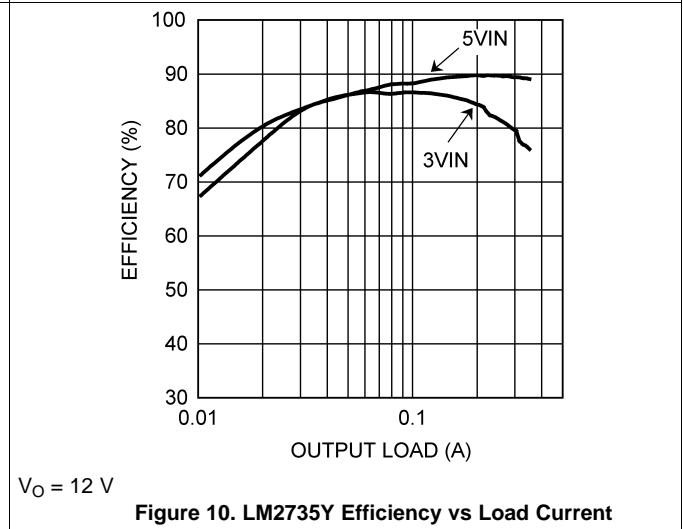
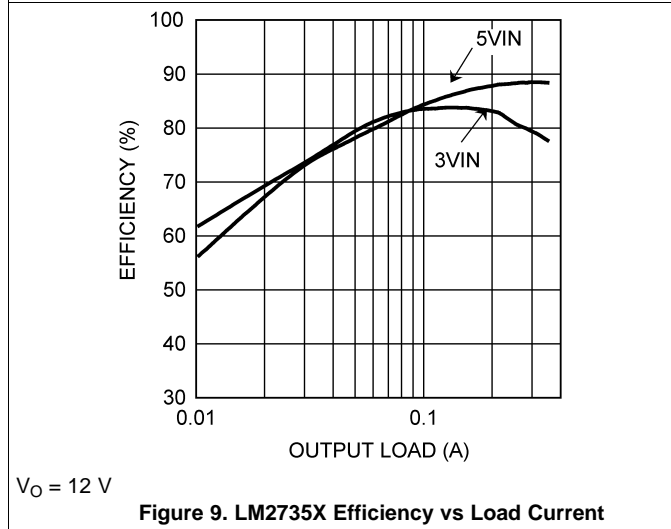
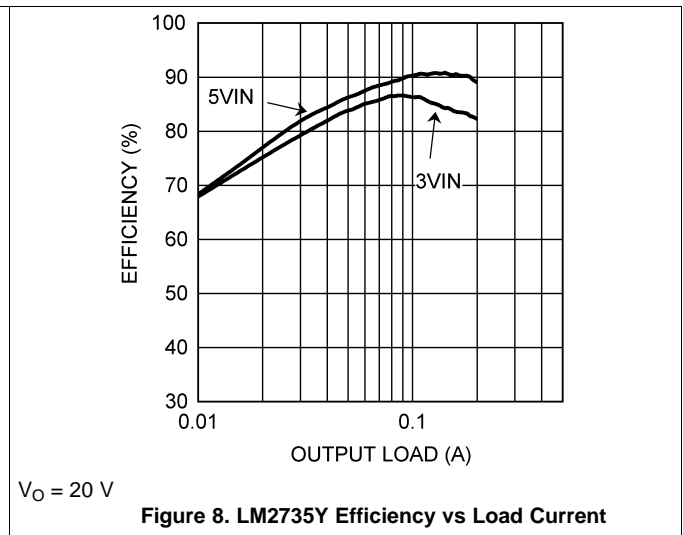
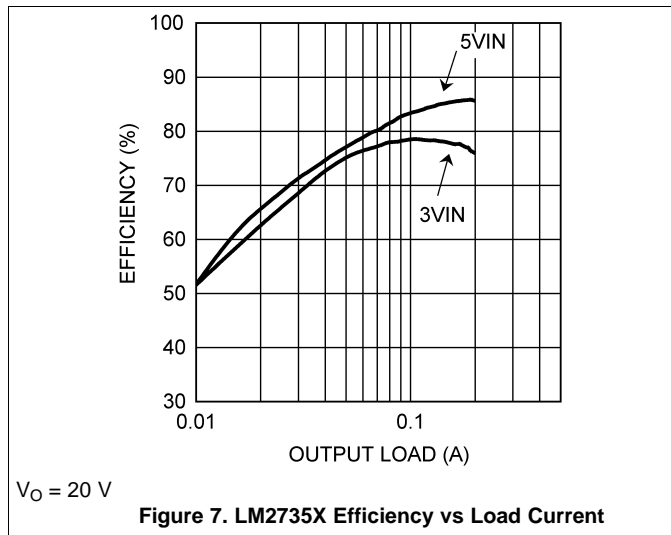

Figure 6. $R_{DS(ON)}$ vs Temperature

Typical Characteristics (continued)



7 Detailed Description

7.1 Overview

The LM2735 device is highly efficient and easy-to-use switching regulator for boost and SEPIC applications. The device provides regulated DC output with fast transient response. Device architecture (current mode control) and internal compensation enable solutions with minimum number of external components. Additionally high switching frequency allows for use of small external passive components (chip capacitors, SMD inductors) and enables power solutions with very small PCB area. LM2735 also provides features such as soft start, pulse-by-pulse current-limit, and thermal shutdown.

7.1.1 Theory of Operation

The LM2735 is a constant-frequency PWM boost regulator IC that delivers a minimum of 2.1 A peak switch current. The regulator has a preset switching frequency of either 520 kHz or 1.6 MHz. This high frequency allows the device to operate with small surface mount capacitors and inductors, resulting in a DC-DC converter that requires a minimum amount of board space. The LM2735 is internally compensated, so it is simple to use, and requires few external components. The device uses current-mode control to regulate the output voltage. The following operating description of the LM2735 refers to the simplified internal block diagram ([Functional Block Diagram](#)), the simplified schematic ([Figure 13](#)), and its associated waveforms ([Figure 14](#)). The LM2735 supplies a regulated output voltage by switching the internal NMOS control switch at constant frequency and variable duty cycle. A switching cycle begins at the falling edge of the reset pulse generated by the internal oscillator. When this pulse goes low, the output control logic turns on the internal NMOS control switch. During this on-time, the SW pin voltage (V_{SW}) decreases to approximately GND, and the inductor current (I_L) increases with a linear slope. I_L is measured by the current sense amplifier, which generates an output proportional to the switch current. The sensed signal is summed with the corrective ramp of the regulator and compared to the error amplifier's output, which is proportional to the difference between the feedback voltage and V_{REF} . When the PWM comparator output goes high, the output switch turns off until the next switching cycle begins. During the switch off-time, inductor current discharges through diode D1, which forces the SW pin to swing to the output voltage plus the forward voltage (V_D) of the diode. The regulator loop adjusts the duty cycle (D) to maintain a constant output voltage .

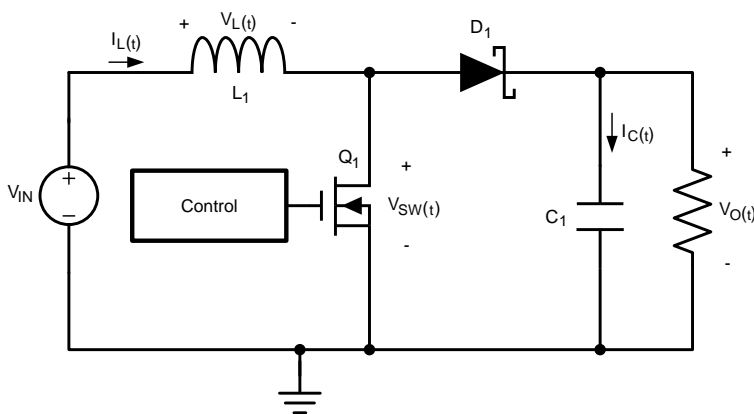
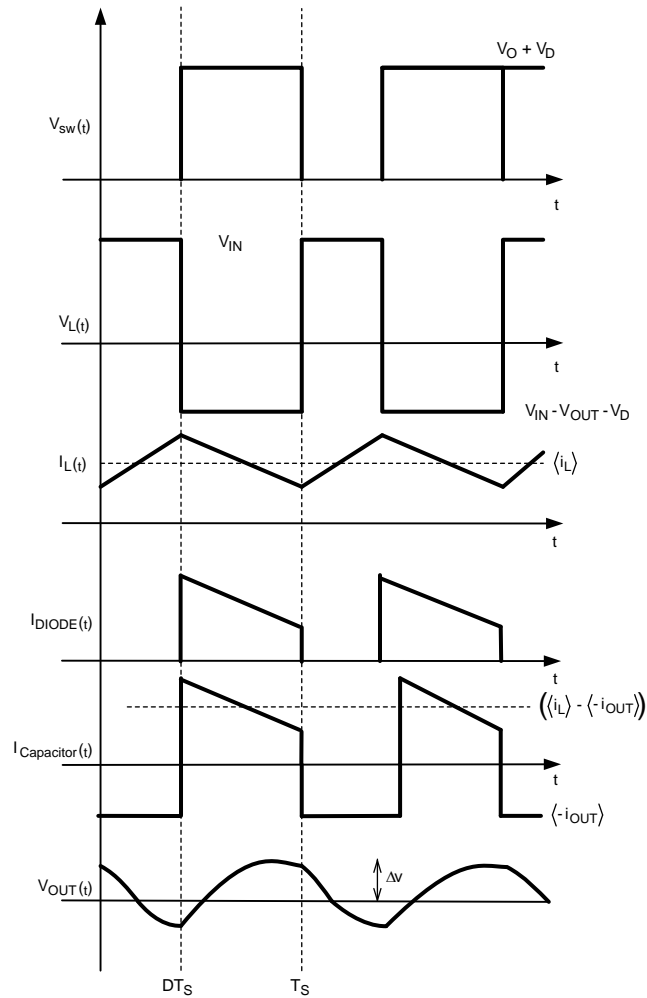
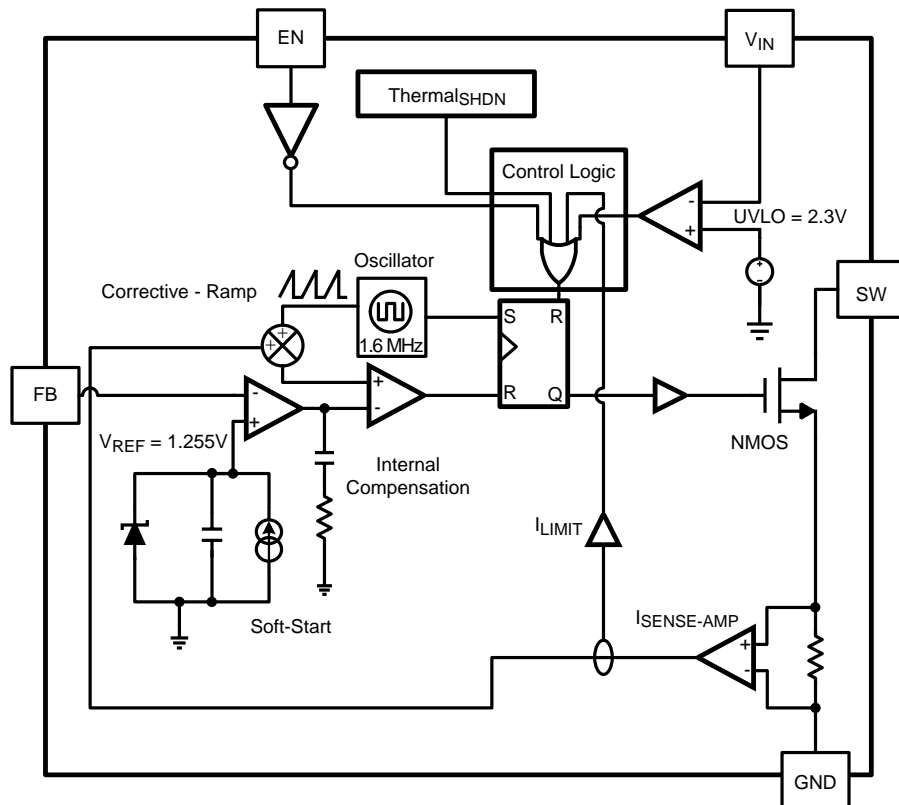

Figure 13. Simplified Schematic

Overview (continued)

Figure 14. Typical Waveforms

7.2 Functional Block Diagram



7.3 Feature Description

7.3.1 Current Limit

The LM2735 uses cycle-by-cycle current limiting to protect the internal NMOS switch. It is important to note that this current limit will not protect the output from excessive current during an output short circuit. The input supply is connected to the output by the series connection of an inductor and a diode. If a short circuit is placed on the output, excessive current can damage both the inductor and diode.

7.3.2 Thermal Shutdown

Thermal shutdown limits total power dissipation by turning off the output switch when the IC junction temperature exceeds 160°C. After thermal shutdown occurs, the output switch does not turn on until the junction temperature drops to approximately 150°C.

7.3.3 Soft Start

This function forces V_{OUT} to increase at a controlled rate during start-up. During soft start, the reference voltage of the error amplifier ramps to its nominal value of 1.255 V in approximately 4 ms. This forces the regulator output to ramp up in a more linear and controlled fashion, which helps reduce inrush current.

7.3.4 Compensation

The LM2735 uses constant-frequency peak current mode control. This mode of control allows for a simple external compensation scheme that can be optimized for each application. A complicated mathematical analysis can be completed to fully explain the internal and external compensation of the LM2735, but for simplicity, a graphical approach with simple equations will be used. Below is a Gain and Phase plot of a LM2735 that produces a 12-V output from a 5-V input voltage. The Bode plot shows the total loop Gain and Phase without external compensation.

Feature Description (continued)

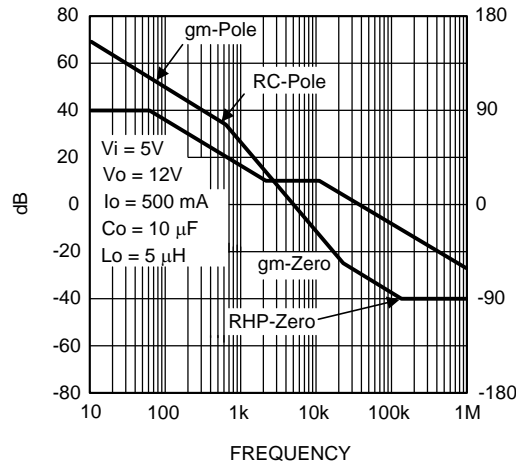

Figure 15. LM2735 Without External Compensation

One can see that the crossover frequency is fine, but the phase margin at 0 dB is very low (22°). A zero can be placed just above the crossover frequency so that the phase margin will be bumped up to a minimum of 45°. Below is the same application with a zero added at 8 kHz.

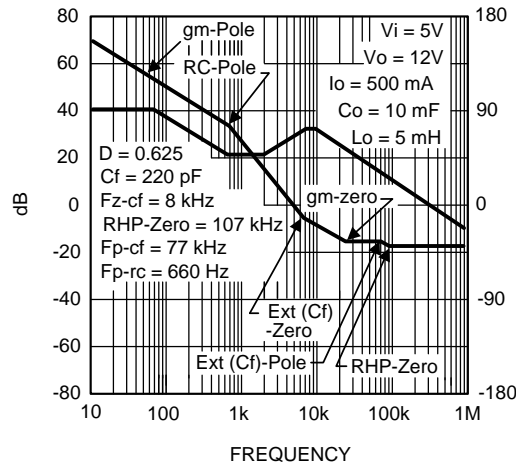

Figure 16. LM2735 With External Compensation

The simplest method to determine the compensation component value is as follows.

Set the output voltage with the following equation.

$$R_2 = \left(\frac{V_{OUT}}{V_{REF}} - 1 \right) \times R_1$$

where

- R1 is the bottom resistor and R2 is the resistor tied to the output voltage. (1)

The next step is to calculate the value of C3. The internal compensation has been designed so that when a zero is added from 5 kHz to 10 kHz, the converter will have good transient response with plenty of phase margin for all input and output voltage combinations.

$$F_{ZERO-CF} = \frac{1}{2\pi(R_2 \times C_f)} = 5 \text{ kHz} \rightarrow 10 \text{ kHz} \tag{2}$$

Feature Description (continued)

Lower output voltages will have the zero set closer to 10 kHz, and higher output voltages will usually have the zero set closer to 5 kHz. TI recommends obtaining a Gain and Phase plot for your actual application. See [Application and Implementation](#) to obtain examples of working applications and the associated component values.

Pole at origin due to internal GM amplifier:

$$F_{P-ORIGIN} \quad (3)$$

Pole due to output load and capacitor:

$$F_{P-RC} = \frac{1}{2\pi(R_{LOAD}C_{OUT})} \quad (4)$$

This equation only determines the frequency of the pole for perfect current mode control (CMC). That is, it doesn't take into account the additional internal artificial ramp that is added to the current signal for stability reasons. By adding artificial ramp, you begin to move away from CMC to voltage mode control (VMC). The artifact is that the pole due to the output load and output capacitor will actually be slightly higher in frequency than calculated. In this example, it is calculated at 650 Hz, but in reality, it is around 1 kHz.

The zero created with capacitor C3 & resistor R2:

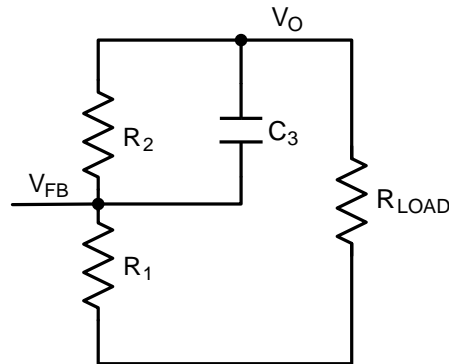

Figure 17. Setting External Pole-Zero

$$F_{ZERO-CF} = \frac{1}{2\pi(R_2 \times C_3)} \quad (5)$$

There is an associated pole with the zero that was created in the above equation.

$$F_{POLE-CF} = \frac{1}{2\pi((R_1 || R_2) \times C_3)} \quad (6)$$

It is always higher in frequency than the zero.

A right-half plane zero (RHPZ) is inherent to all boost converters. One must remember that the gain associated with a right-half plane zero increases at 20 dB per decade, but the phase decreases by 45° per decade. For most applications there is little concern with the RHPZ due to the fact that the frequency at which it shows up is well beyond crossover, and has little to no effect on loop stability. One must be concerned with this condition for large inductor values and high output currents.

$$RHP_{ZERO} = \frac{(D)^2 R_{LOAD}}{2\pi \times L} \quad (7)$$

There are miscellaneous poles and zeros associated with parasitics internal to the LM2735, external components, and the PCB. They are located well over the crossover frequency, and for simplicity are not discussed.

7.4 Device Functional Modes

7.4.1 Enable Pin and Shutdown Mode

The LM2735 has a shutdown mode that is controlled by the Enable pin (EN). When a logic low voltage is applied to EN, the part is in shutdown mode and its quiescent current drops to typically 80 nA. Switch leakage adds up to another 1 μ A from the input supply. The voltage at this pin should never exceed $V_{IN} + 0.3$ V.

8 Application and Implementation

NOTE

Information in the following applications sections is not part of the TI component specification, and TI does not warrant its accuracy or completeness. TI's customers are responsible for determining suitability of components for their purposes. Customers should validate and test their design implementation to confirm system functionality.

8.1 Application Information

The device will operate with input voltage in the range of 2.7 V to 5.5 V and provide regulated output voltage. This device is optimized for high-efficiency operation with minimum number of external components. For component selection, see [Detailed Design Procedure](#).

8.2 Typical Applications

8.2.1 LM2735X SOT-23 Design Example 1

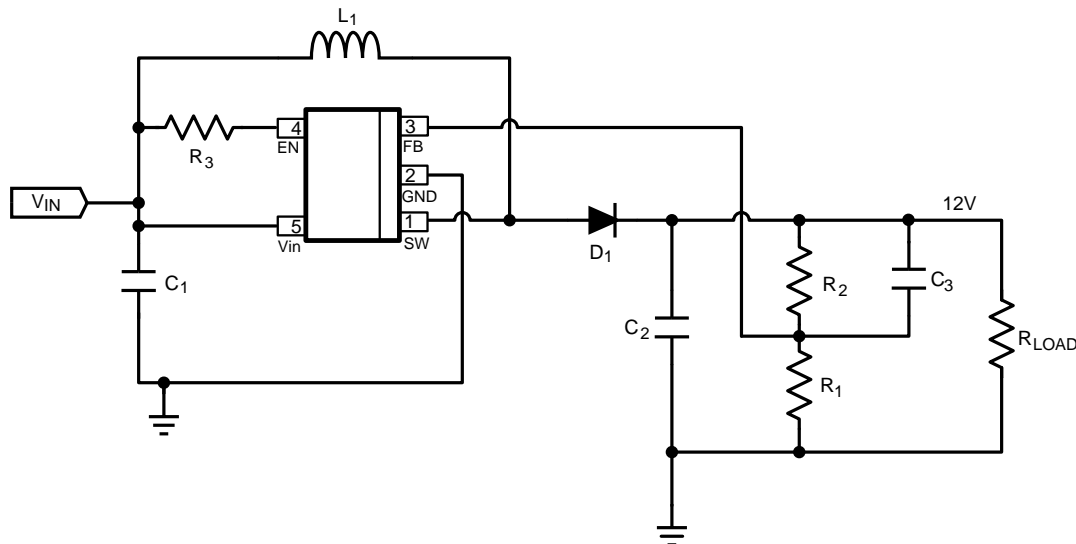

Figure 18. LM2735X (1.6 MHz): $V_{IN} = 5$ V, $V_{OUT} = 12$ V @ 350 mA

8.2.1.1 Design Requirements

The device must be able to operate at any voltage within input voltage range.

The load current needs to be defined in order to properly size the inductor, input capacitor, and output capacitor. The inductor must be able to handle full expected load current as well as the peak current generated during load transients and start-up. The inrush current at startup will depend on the output capacitor selection. More details are provided in [Detailed Design Procedure](#).

The device has an enable pin (EN) that is used to enable and disable the device. This pin is active high and care should be taken that voltage on this pin does not exceed $V_{IN} + 0.3$ V.

Typical Applications (continued)

8.2.1.2 Detailed Design Procedure

Table 1. Bill of Materials

PART ID	PART VALUE	MANUFACTURER	PART NUMBER
U1	2.1-A Boost Regulator	TI	LM2735XMF
C1, Input Capacitor	22 μ F, 6.3 V, X5R	TDK	C2012X5R0J226M
C2 Output Capacitor	10 μ F, 25 V, X5R	TDK	C3216X5R1E106M
C3 Comp Capacitor	330 pF	TDK	C1608X5R1H331K
D1, Catch Diode	0.4 V _f Schottky 1 A, 20 V _R	ST	STPS120M
L1	15 μ H 1.5 A	Coilcraft	MSS5131-153ML
R1	10.2 k Ω , 1%	Vishay	CRCW06031022F
R2	86.6 k Ω , 1%	Vishay	CRCW06038662F
R3	100 k Ω , 1%	Vishay	CRCW06031003F

8.2.1.2.1 Custom Design With WEBENCH® Tools

[Click here](#) to create a custom design using the LM2735 device with the WEBENCH® Power Designer.

1. Start by entering the input voltage (V_{IN}), output voltage (V_{OUT}), and output current (I_{OUT}) requirements.
2. Optimize the design for key parameters such as efficiency, footprint, and cost using the optimizer dial.
3. Compare the generated design with other possible solutions from Texas Instruments.

The WEBENCH Power Designer provides a customized schematic along with a list of materials with real-time pricing and component availability.

In most cases, these actions are available:

- Run electrical simulations to see important waveforms and circuit performance
- Run thermal simulations to understand board thermal performance
- Export customized schematic and layout into popular CAD formats
- Print PDF reports for the design, and share the design with colleagues

Get more information about WEBENCH tools at www.ti.com/WEBENCH.

8.2.1.2.2 Inductor Selection

The duty cycle (D) can be approximated quickly using the ratio of output voltage (V_O) to input voltage (V_{IN}):

$$\frac{V_{OUT}}{V_{IN}} = \left(\frac{1}{1-D} \right) = \frac{1}{D} \quad (8)$$

Therefore:

$$D = \frac{V_{OUT} - V_{IN}}{V_{OUT}} \quad (9)$$

Power losses due to the diode (D1) forward voltage drop, the voltage drop across the internal NMOS switch, the voltage drop across the inductor resistance (R_{DCR}), and switching losses must be included to calculate a more accurate duty cycle (see [Calculating Efficiency, and Junction Temperature](#) for a detailed explanation). A more accurate formula for calculating the conversion ratio is:

$$\frac{V_{OUT}}{V_{IN}} = \frac{\eta}{D}$$

where

- η equals the efficiency of the LM2735 application. (10)

The inductor value determines the input ripple current. Lower inductor values decrease the size of the inductor, but increase the input ripple current. An increase in the inductor value will decrease the input ripple current.

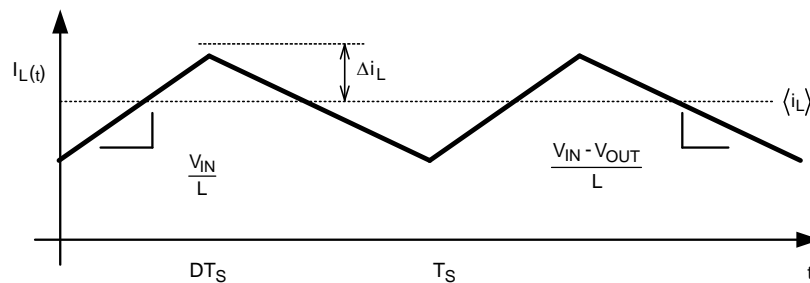
Figure 19. Inductor Current

$$\frac{2\Delta i_L}{DT_S} = \left(\frac{V_{IN}}{L} \right)$$

$$\Delta i_L = \left(\frac{V_{IN}}{2L} \right) \times DT_S \quad (11)$$

A good design practice is to design the inductor to produce 10% to 30% ripple of maximum load. From the previous equations, the inductor value is then obtained.

$$L = \left(\frac{V_{IN}}{2 \times \Delta i_L} \right) \times DT_S$$

where

- $1/T_S = F_{SW} =$ switching frequency (12)

Ensure that the minimum current limit (2.1 A) is not exceeded, so the peak current in the inductor must be calculated. The peak current ($I_{L_{PK}}$) in the inductor is calculated by:

$$I_{L_{pk}} = I_{IN} + \Delta I_L \quad (13)$$

or

$$I_{L_{pk}} = I_{OUT} / D' + \Delta I_L \quad (14)$$

When selecting an inductor, make sure that it is capable of supporting the peak input current without saturating. Inductor saturation will result in a sudden reduction in inductance and prevent the regulator from operating correctly. Because of the speed of the internal current limit, the peak current of the inductor need only be specified for the required maximum input current. For example, if the designed maximum input current is 1.5 A and the peak current is 1.75 A, then the inductor should be specified with a saturation current limit of >1.75 A. There is no need to specify the saturation or peak current of the inductor at the 3-A typical switch current-limit.

Because of the operating frequency of the LM2735, ferrite based inductors are preferred to minimize core losses. This presents little restriction since the variety of ferrite-based inductors is huge. Lastly, inductors with lower series resistance (DCR) will provide better operating efficiency. For recommended inductors, see the following design examples.

8.2.1.2.3 Input Capacitor

An input capacitor is necessary to ensure that V_{IN} does not drop excessively during switching transients. The primary specifications of the input capacitor are capacitance, voltage, RMS current rating, and ESL (Equivalent Series Inductance). The recommended input capacitance is 10 μ F to 44 μ F depending on the application. The capacitor manufacturer specifically states the input voltage rating. Make sure to check any recommended deratings and also verify if there is any significant change in capacitance at the operating input voltage and the operating temperature. The ESL of an input capacitor is usually determined by the effective cross sectional area of the current path. At the operating frequencies of the LM2735, certain capacitors may have an ESL so large that the resulting impedance ($2\pi fL$) will be higher than that required to provide stable operation. As a result, surface mount capacitors are strongly recommended. Multilayer ceramic capacitors (MLCC) are good choices for both input and output capacitors and have very low ESL. For MLCCs, TI recommends using X7R or X5R dielectrics. Consult capacitor manufacturer datasheet to see how rated capacitance varies over operating conditions.

8.2.1.2.4 Output Capacitor

The LM2735 operates at frequencies allowing the use of ceramic output capacitors without compromising transient response. Ceramic capacitors allow higher inductor ripple without significantly increasing output ripple. The output capacitor is selected based upon the desired output ripple and transient response. The initial current of a load transient is provided mainly by the output capacitor. The output impedance will therefore determine the maximum voltage perturbation. The output ripple of the converter is a function of the reactance of the capacitor and its equivalent series resistance (ESR):

$$\Delta V_{\text{OUT}} = \Delta I_L \times R_{\text{ESR}} + \left(\frac{V_{\text{OUT}} \times D}{2 \times F_{\text{SW}} \times R_{\text{Load}} \times C_{\text{OUT}}} \right) \quad (15)$$

When using MLCCs, the ESR is typically so low that the capacitive ripple may dominate. When this occurs, the output ripple will be approximately sinusoidal and 90° phase shifted from the switching action.

Given the availability and quality of MLCCs and the expected output voltage of designs using the LM2735, there is really no need to review any other capacitor technologies. Another benefit of ceramic capacitors is their ability to bypass high-frequency noise. A certain amount of switching edge noise will couple through parasitic capacitances in the inductor to the output. A ceramic capacitor will bypass this noise while a tantalum will not. Since the output capacitor is one of the two external components that control the stability of the regulator control loop, most applications will require a minimum at 4.7 μF of output capacitance. Like the input capacitor, recommended multilayer ceramic capacitors are X7R or X5R. Again, verify actual capacitance at the desired operating voltage and temperature.

8.2.1.2.5 Setting the Output Voltage

The output voltage is set using the following equation where R1 is connected between the FB pin and GND, and R2 is connected between V_{OUT} and the FB pin.

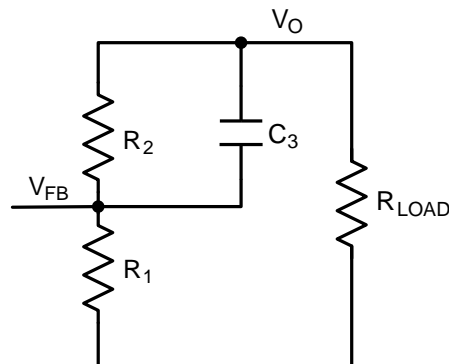
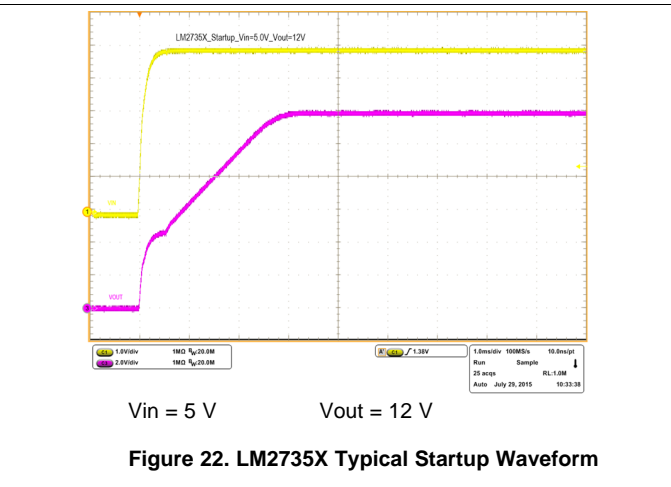
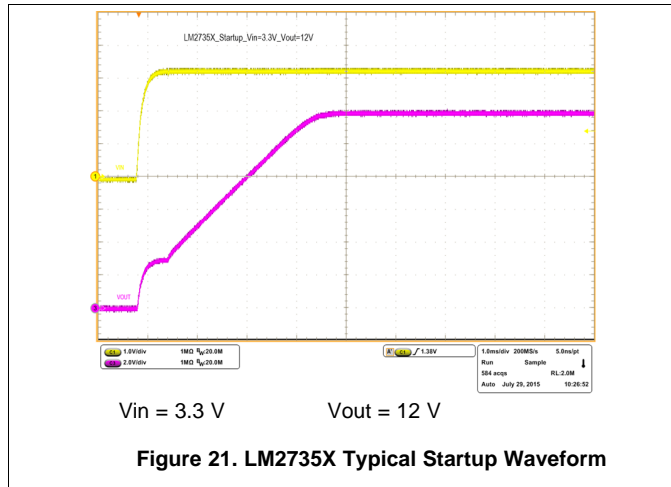

Figure 20. Setting V_{out}

A good value for R1 is 10 kΩ.

$$R_2 = \left(\frac{V_{\text{OUT}}}{V_{\text{REF}}} - 1 \right) \times R_1 \quad (16)$$

8.2.1.3 Application Curves



8.2.2 LM2735Y SOT-23 Design Example 2

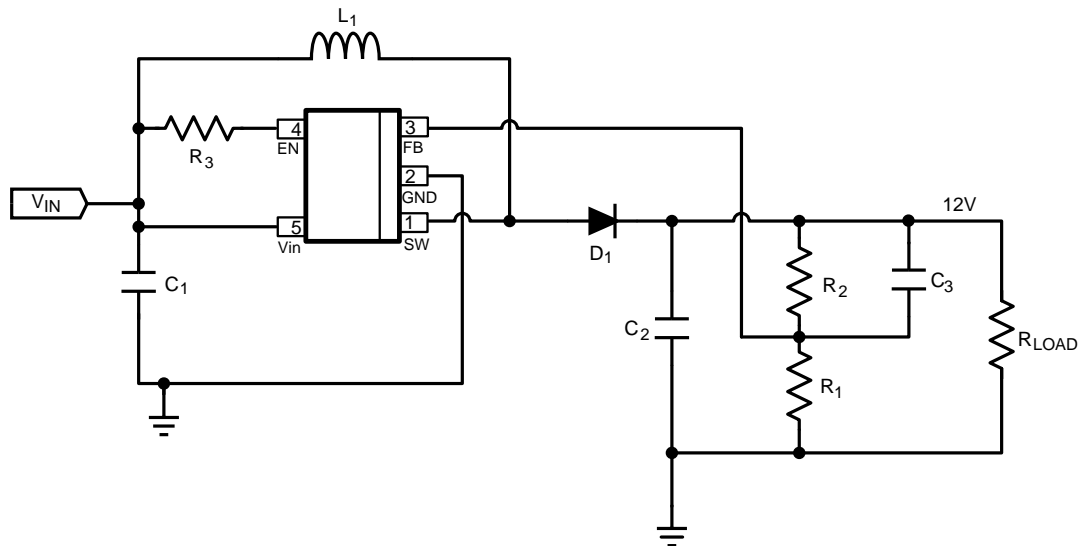
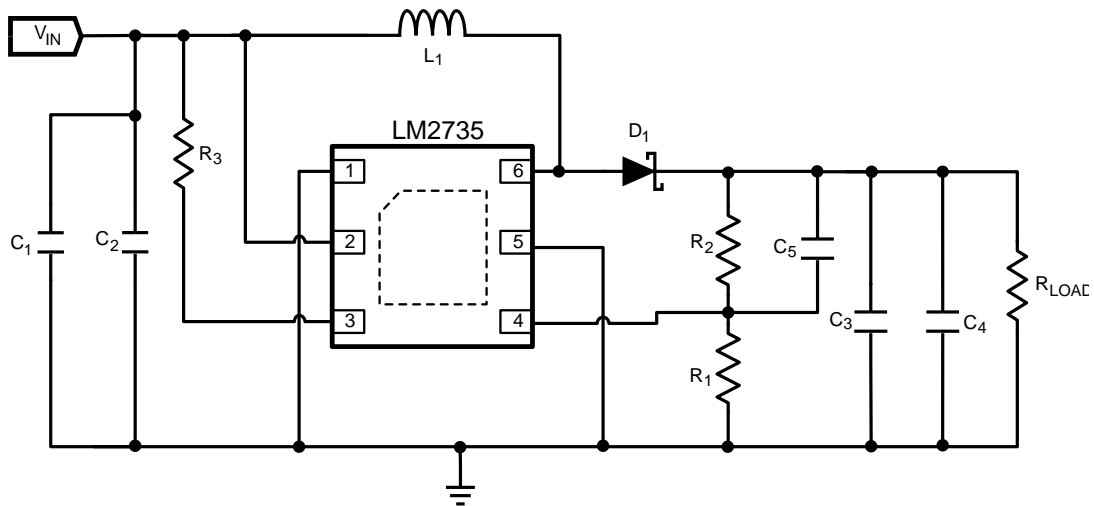

Figure 23. LM2735Y (520 kHz): $V_{IN} = 5 V$, $V_{OUT} = 12 V$ at 350 mA

PART ID	PART VALUE	MANUFACTURER	PART NUMBER
U1	2.1-A Boost Regulator	TI	LM2735YMF
C1, Input Capacitor	22 μ F, 6.3 V, X5R	TDK	C2012X5R0J226M
C2 Output Capacitor	10 μ F, 25 V, X5R	TDK	C3216X5R1E106M
C3 Comp Capacitor	330 pF	TDK	C1608X5R1H331K
D1, Catch Diode	0.4 V _f Schottky 1 A, 20 V _R	ST	STPS120M
L1	33 μ H 1.5 A	Coilcraft	DS3316P-333ML
R1	10.2 k Ω , 1%	Vishay	CRCW06031022F
R2	86.6 k Ω , 1%	Vishay	CRCW06038662F
R3	100 k Ω , 1%	Vishay	CRCW06031003F

8.2.3 LM2735X WSON Design Example 3

Figure 24. LM2735X (1.6 MHz): $V_{IN} = 3.3\text{ V}$, $V_{OUT} = 12\text{ V}$ at 350 mA

PART ID	PART VALUE	MANUFACTURER	PART NUMBER
U1	2.1-A Boost Regulator	TI	LM2735XSD
C1 Input Capacitor	22 μF , 6.3 V, X5R	TDK	C2012X5R0J226M
C2 Input Capacitor	No Load		
C3 Output Capacitor	10 μF , 25 V, X5R	TDK	C3216X5R1E106M
C4 Output Capacitor	No Load		
C5 Comp Capacitor	330 pF	TDK	C1608X5R1H331K
D1, Catch Diode	0.4 V_f Schottky 1 A, 20 V_R	ST	STPS120M
L1	6.8 μH 2 A	Coilcraft	DO1813H-682ML
R1	10.2 k Ω , 1%	Vishay	CRCW06031022F
R2	86.6 k Ω , 1%	Vishay	CRCW06038662F
R3	100 k Ω , 1%	Vishay	CRCW06031003F

LM2735

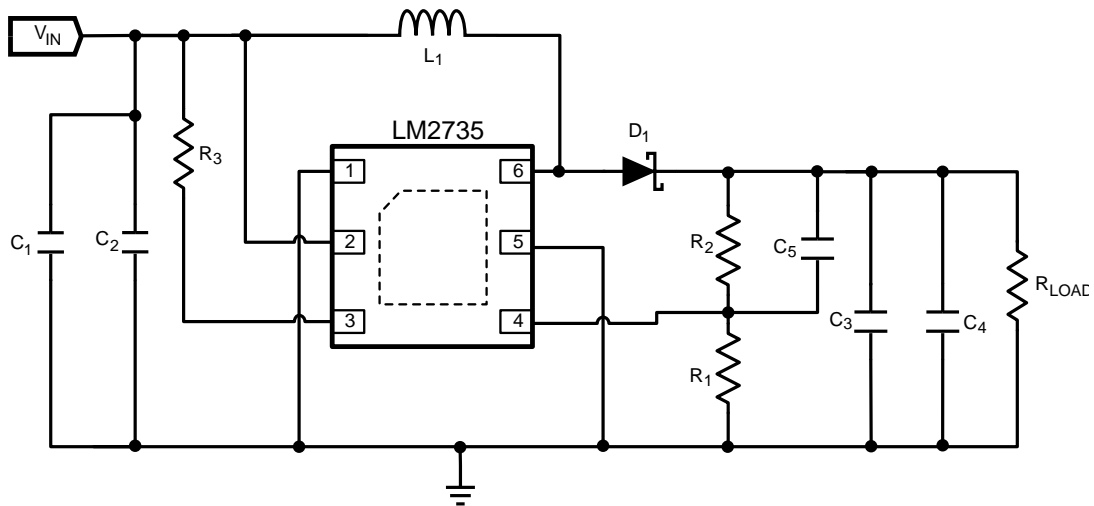
SNVS485I – JUNE 2007 – REVISED SEPTEMBER 2018

www.ti.com
8.2.4 LM2735Y WSON Design Example 4

Figure 25. LM2735Y (520 kHz): $V_{IN} = 3.3\text{ V}$, $V_{OUT} = 12\text{ V}$ at 350 mA

PART ID	PART VALUE	MANUFACTURER	PART NUMBER
U1	2.1-A Boost Regulator	TI	LM2735YSD
C1 Input Capacitor	22 μF , 6.3 V, X5R	TDK	C2012X5R0J226M
C2 Input Capacitor	No Load		
C3 Output Capacitor	10 μF , 25 V, X5R	TDK	C3216X5R1E106M
C4 Output Capacitor	No Load		
C5 Comp Capacitor	330 pF	TDK	C1608X5R1H331K
D1, Catch Diode	0.4 V_f Schottky 1 A, 20 V_R	ST	STPS120M
L1	15 μH 2 A	Coilcraft	MSS5131-153ML
R1	10.2 k Ω , 1%	Vishay	CRCW06031022F
R2	86.6 k Ω , 1%	Vishay	CRCW06038662F
R3	100 k Ω , 1%	Vishay	CRCW06031003F

8.2.5 LM2735Y MSOP-PowerPAD Design Example 5

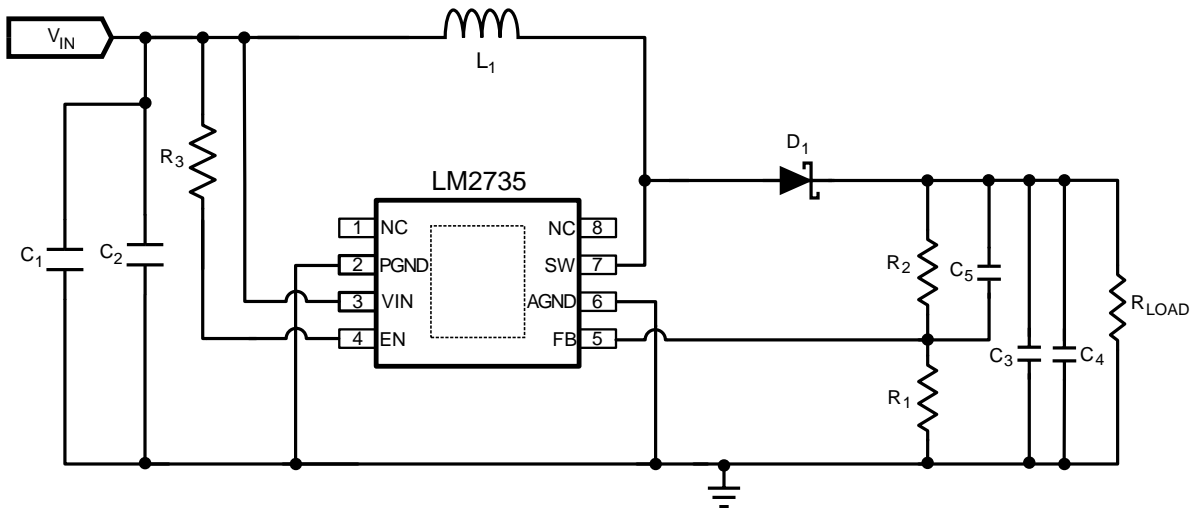
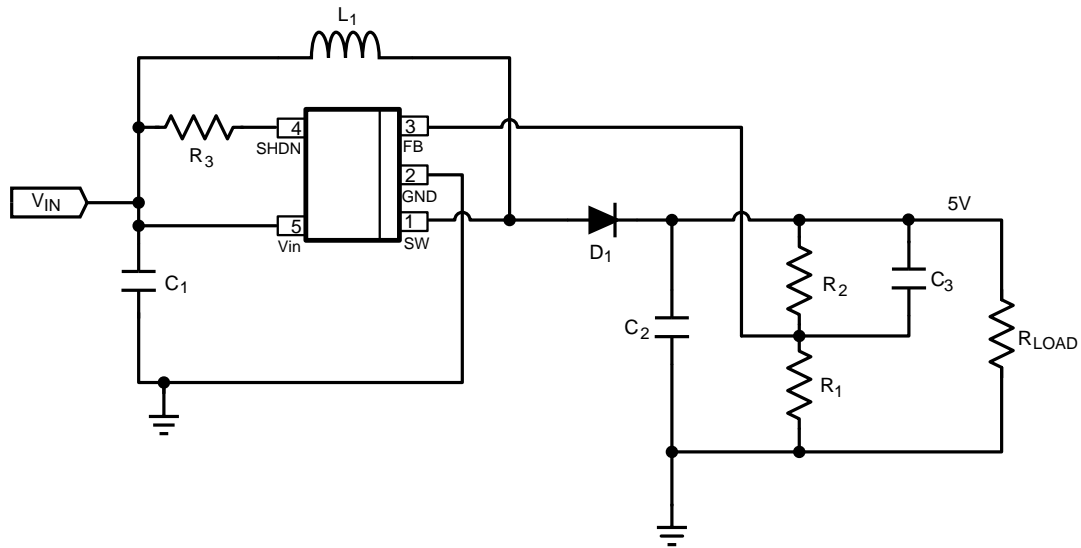
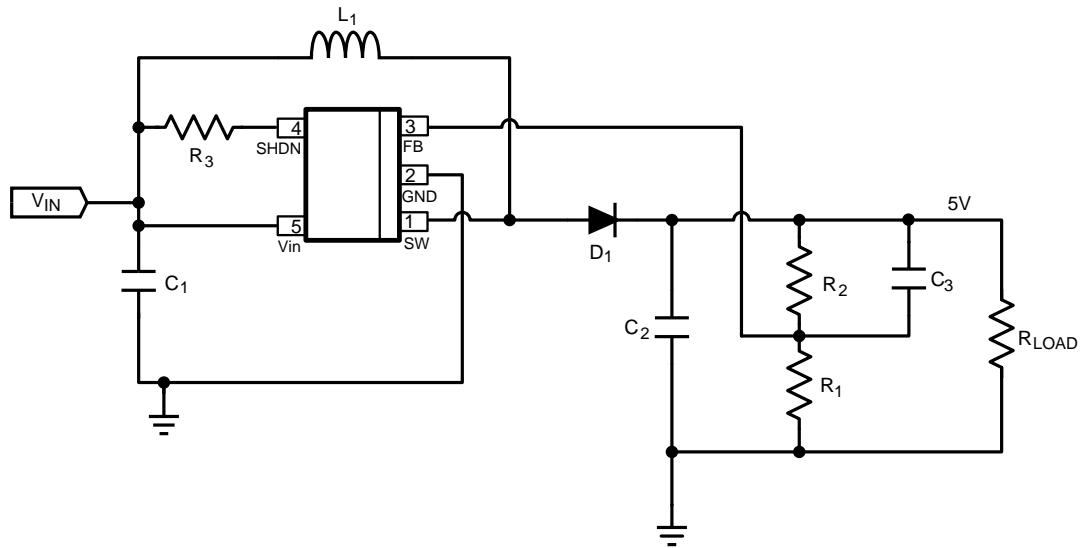

Figure 26. LM2735Y (520 kHz): $V_{IN} = 3.3\text{ V}$, $V_{OUT} = 12\text{ V}$ at 350 mA

PART ID	PART VALUE	MANUFACTURER	PART NUMBER
U1	2.1-A Boost Regulator	TI	LM2735YMY
C1 Input Capacitor	22 μF , 6.3 V, X5R	TDK	C2012X5R0J226M
C2 Input Capacitor	No Load		
C3 Output Capacitor	10 μF , 25 V, X5R	TDK	C3216X5R1E106M
C4 Output Capacitor	No Load		
C5 Comp Capacitor	330 pF	TDK	C1608X5R1H331K
D1, Catch Diode	0.4 V_f Schottky 1 A, 20 V_R	ST	STPS120M
L1	15 μH 1.5 A	Coilcraft	MSS5131-153ML
R1	10.2 k Ω , 1%	Vishay	CRCW06031022F
R2	86.6 k Ω , 1%	Vishay	CRCW06038662F
R3	100 k Ω , 1%	Vishay	CRCW06031003F

8.2.6 LM2735X SOT-23 Design Example 6

Figure 27. LM2735X (1.6 MHz): $V_{IN} = 3\text{ V}$, $V_{OUT} = 5\text{ V}$ at 500 mA

PART ID	PART VALUE	MANUFACTURER	PART NUMBER
U1	2.1-A Boost Regulator	TI	LM2735XMF
C1, Input Capacitor	10 μF , 6.3 V, X5R	TDK	C2012X5R0J106K
C2, Output Capacitor	10 μF , 6.3 V, X5R	TDK	C2012X5R0J106K
C3 Comp Capacitor	1000 pF	TDK	C1608X5R1H102K
D1, Catch Diode	0.4 V_f Schottky 1 A, 20 V_R	ST	STPS120M
L1	10 μH 1.2 A	Coilcraft	DO1608C-103ML
R1	10.0 k Ω , 1%	Vishay	CRCW08051002F
R2	30.1 k Ω , 1%	Vishay	CRCW08053012F
R3	100 k Ω , 1%	Vishay	CRCW06031003F

8.2.7 LM2735Y SOT-23 Design Example 7

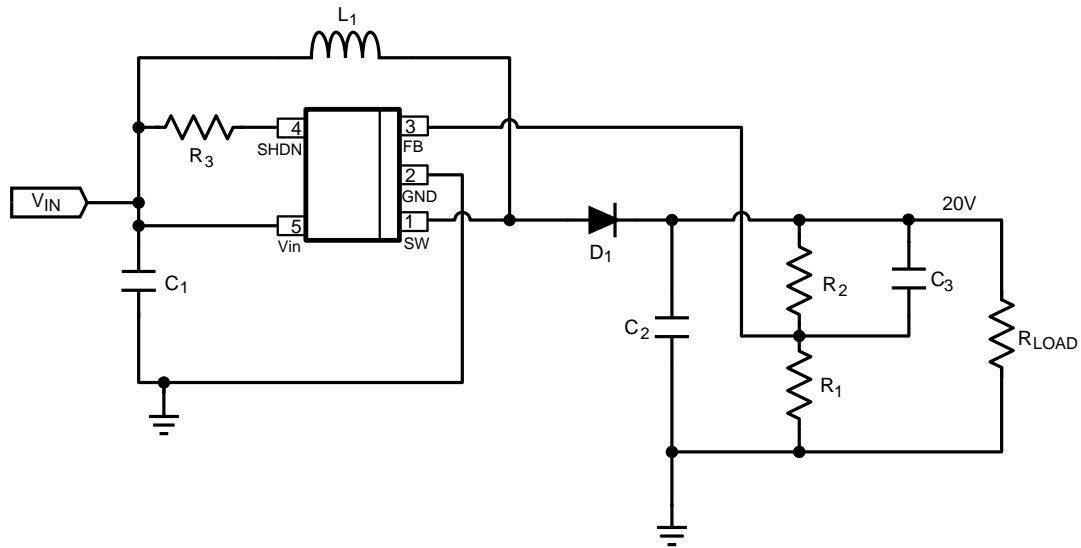
Figure 28. LM2735Y (520 kHz): $V_{IN} = 3\text{ V}$, $V_{OUT} = 5\text{ V}$ at 750 mA

PART ID	PART VALUE	MANUFACTURER	PART NUMBER
U1	2.1-A Boost Regulator	TI	LM2735YMF
C1 Input Capacitor	22 μF , 6.3 V, X5R	TDK	C2012X5R0J226M
C2 Output Capacitor	22 μF , 6.3 V, X5R	TDK	C2012X5R0J226M
C3 Comp Capacitor	1000 pF	TDK	C1608X5R1H102K
D1, Catch Diode	0.4 V_f Schottky 1 A, 20 V_R	ST	STPS120M
L1	22 μH 1.2 A	Coilcraft	MSS5131-223ML
R1	10.0 k Ω , 1%	Vishay	CRCW08051002F
R2	30.1 k Ω , 1%	Vishay	CRCW08053012F
R3	100 k Ω , 1%	Vishay	CRCW06031003F

8.2.8 LM2735X SOT-23 Design Example 8

Figure 29. LM2735X (1.6 MHz): $V_{IN} = 3.3\text{ V}$, $V_{out} = 20\text{ V}$ at 100 mA

PART ID	PART VALUE	MANUFACTURER	PART NUMBER
U1	2.1-A Boost Regulator	TI	LM2735XMF
C1, Input Capacitor	22 μF , 6.3 V, X5R	TDK	C2012X5R0J226M
C2, Output Capacitor	4.7 μF , 25 V, X5R	TDK	C3216X5R1E475K
C3 Comp Capacitor	470 pF	TDK	C1608X5R1H471K
D1, Catch Diode	0.4 V_f Schottky 500 mA, 30 V_R	Vishay	MBR0530
L1	10 μH 1.2 A	Coilcraft	DO1608C-103ML
R1	10.0 k Ω , 1%	Vishay	CRCW06031002F
R2	150 k Ω , 1%	Vishay	CRCW06031503F
R3	100 k Ω , 1%	Vishay	CRCW06031003F

8.2.9 LM2735Y SOT-23 Design Example 9

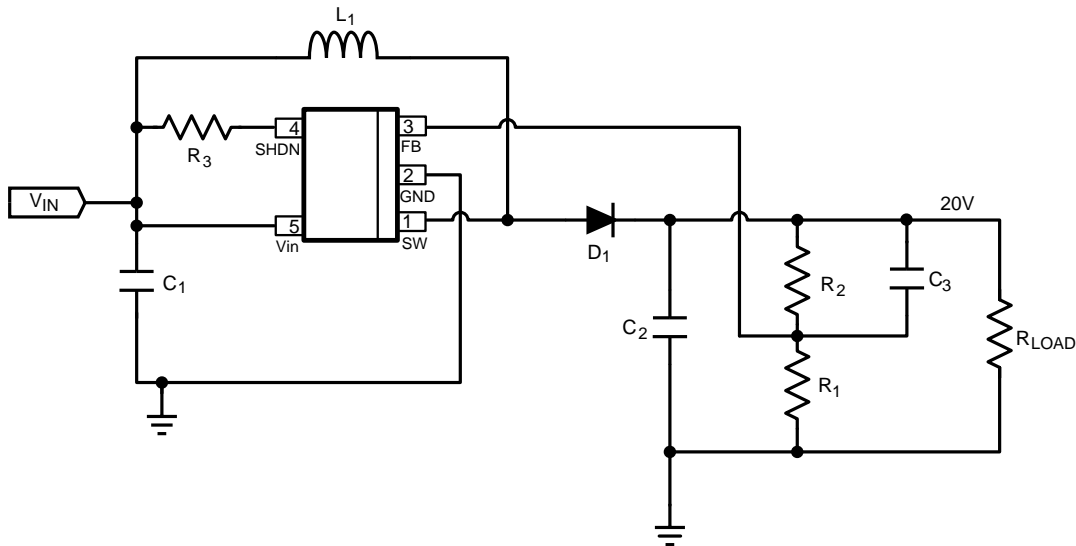
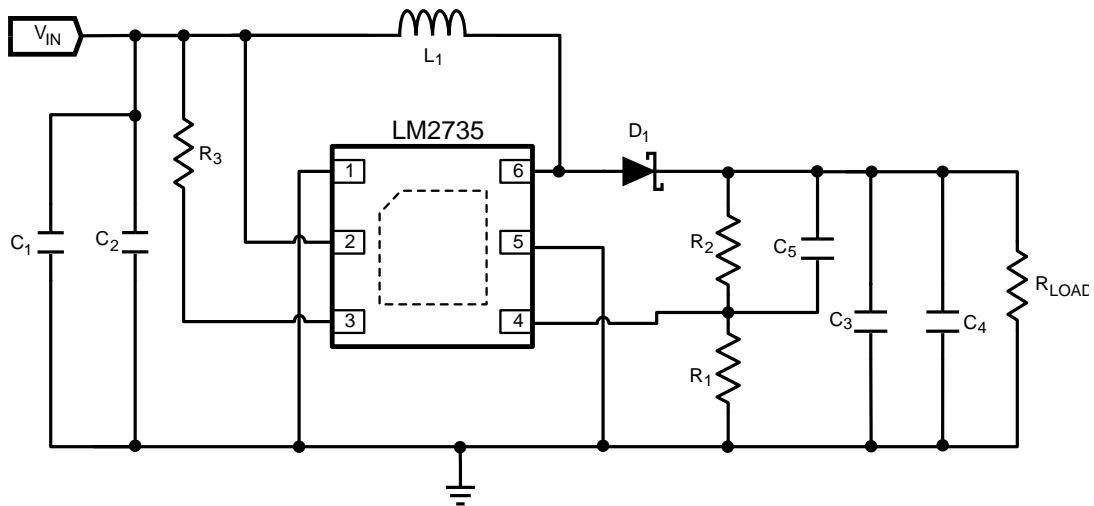
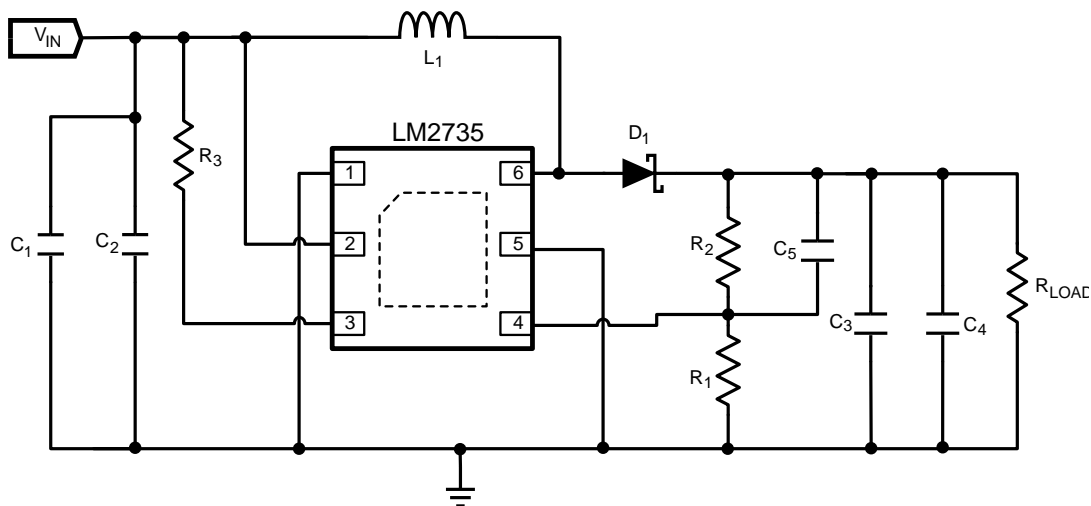

Figure 30. LM2735Y (520 kHz): $V_{IN} = 3.3\text{ V}$, $V_{OUT} = 20\text{ V}$ at 100 mA

PART ID	PART VALUE	MANUFACTURER	PART NUMBER
U1	2.1-A Boost Regulator	TI	LM2735YMF
C1 Input Capacitor	22 μF , 6.3 V, X5R	TDK	C2012X5R0J226M
C2 Output Capacitor	10 μF , 25 V, X5R	TDK	C3216X5R1E106M
C3 Comp Capacitor	470 pF	TDK	C1608X5R1H471K
D1, Catch Diode	0.4 V_f Schottky 500 mA, 30 V_R	Vishay	MBR0530
L1	33 μH 1.5 A	Coilcraft	DS3316P-333ML
R1	10.0 k Ω , 1%	Vishay	CRCW06031002F
R2	150.0 k Ω , 1%	Vishay	CRCW06031503F
R3	100 k Ω , 1%	Vishay	CRCW06031003F

8.2.10 LM2735X WSON Design Example 10

Figure 31. LM2735X (1.6 MHz): $V_{IN} = 3.3\text{ V}$, $V_{OUT} = 20\text{ V}$ at 150 mA

PART ID	PART VALUE	MANUFACTURER	PART NUMBER
U1	2.1-A Boost Regulator	TI	LM2735XSD
C1 Input Capacitor	22 μF , 6.3 V, X5R	TDK	C2012X5R0J226M
C2 Input Capacitor	22 μF , 6.3 V, X5R	TDK	C2012X5R0J226M
C3 Output Capacitor	10 μF , 25 V, X5R	TDK	C3216X5R1E106M
C4 Output Capacitor	No Load		
C5 Comp Capacitor	470 pF	TDK	C1608X5R1H471K
D1, Catch Diode	0.4 V_f Schottky 500 mA, 30 V_R	Vishay	MBR0530
L1	8.2 μH 2 A	Coilcraft	DO1813H-822ML
R1	10.0 k Ω , 1%	Vishay	CRCW06031002F
R2	150 k Ω , 1%	Vishay	CRCW06031503F
R3	100 k Ω , 1%	Vishay	CRCW06031003F

8.2.11 LM2735Y WSON Design Example 11

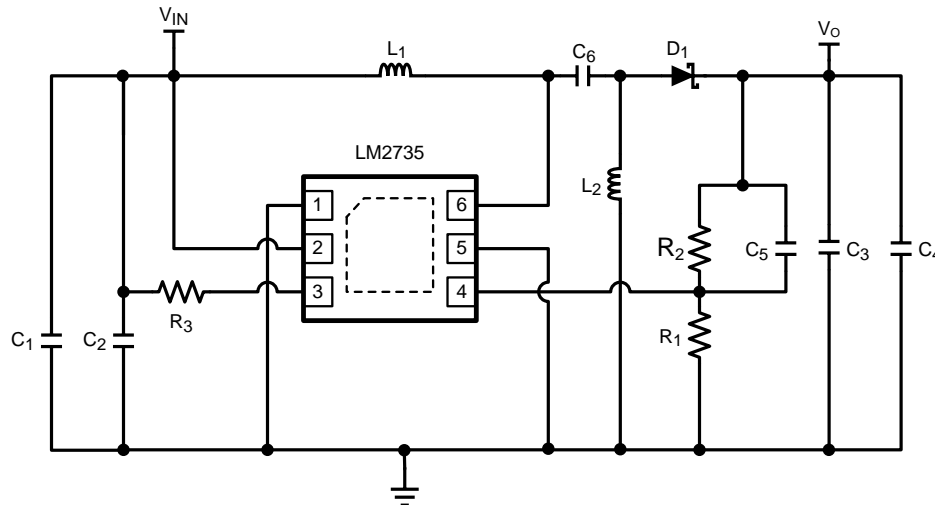
Figure 32. LM2735Y (520 kHz): $V_{IN} = 3.3\text{ V}$, $V_{OUT} = 20\text{ V}$ at 150 mA

PART ID	PART VALUE	MANUFACTURER	PART NUMBER
U1	2.1-A Boost Regulator	TI	LM2735YSD
C1 Input Capacitor	10 μF , 6.3 V, X5R	TDK	C2012X5R0J106K
C2 Input Capacitor	10 μF , 6.3 V, X5R	TDK	C2012X5R0J106K
C3 Output Capacitor	10 μF , 25 V, X5R	TDK	C3216X5R1E106M
C4 Output Capacitor	No Load		
C5 Comp Capacitor	470 pF	TDK	C1608X5R1H471K
D1, Catch Diode	0.4 V_f Schottky 500 mA, 30 V_R	Vishay	MBR0530
L1	22 μH 1.5 A	Coilcraft	DS3316P-223ML
R1	10.0 $\text{k}\Omega$, 1%	Vishay	CRCW06031002F
R2	150 $\text{k}\Omega$, 1%	Vishay	CRCW06031503F
R3	100 $\text{k}\Omega$, 1%	Vishay	CRCW06031003F

8.2.12 LM2735X WSON SEPIC Design Example 12

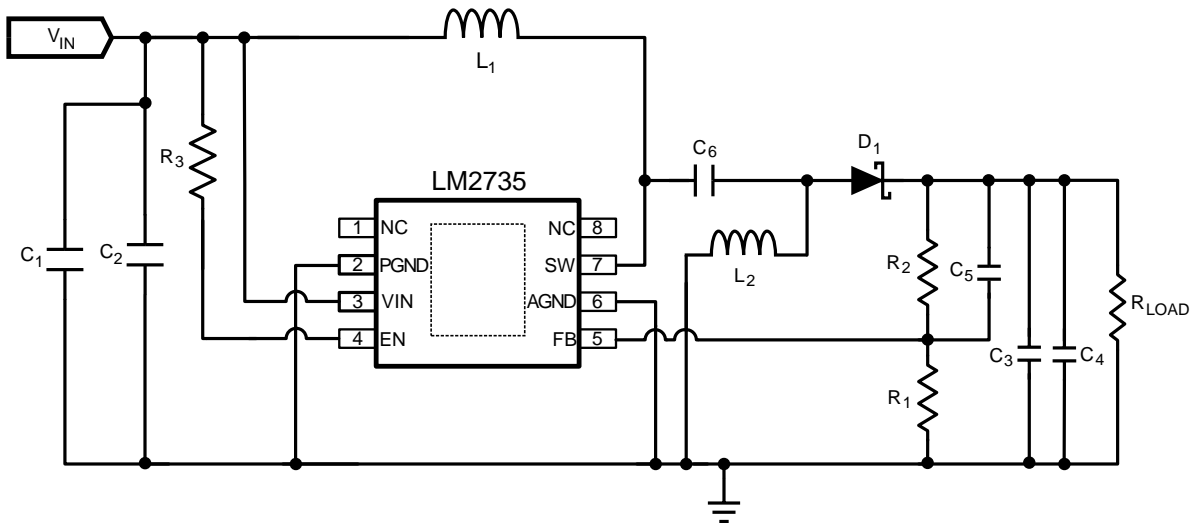
Figure 33. LM2735X (1.6 MHz): $V_{IN} = 2.7\text{ V} - 5\text{ V}$, $V_{OUT} = 3.3\text{ V}$ at 500 mA

PART ID	PART VALUE	MANUFACTURER	PART NUMBER
U1	2.1-A Boost Regulator	TI	LM2735XSD
C1 Input Capacitor	22 μF , 6.3 V, X5R	TDK	C2012X5R0J226M
C2 Input Capacitor	No Load		
C3 Output Capacitor	10 μF , 25 V, X5R	TDK	C3216X5R1E106M
C4 Output Capacitor	No Load		
C5 Comp Capacitor	2200 pF	TDK	C1608X5R1H222K
C6	2.2 μF 16 V	TDK	C2012X5R1C225K
D1, Catch Diode	0.4 V_f Schottky 1 A, 20 V_R	ST	STPS120M
L1	6.8 μH	Coilcraft	DO1608C-682ML
L2	6.8 μH	Coilcraft	DO1608C-682ML
R1	10.2 k Ω , 1%	Vishay	CRCW06031002F
R2	16.5 k Ω , 1%	Vishay	CRCW06031652F
R3	100 k Ω , 1%	Vishay	CRCW06031003F

8.2.13 LM2735Y MSOP-PowerPAD SEPIC Design Example 13

Figure 34. LM2735Y (520 kHz): $V_{IN} = 2.7\text{ V} - 5\text{ V}$, $V_{OUT} = 3.3\text{ V}$ at 500 mA

PART ID	PART VALUE	MANUFACTURER	PART NUMBER
U1	2.1-A Boost Regulator	TI	LM2735YMY
C1 Input Capacitor	22 μF , 6.3 V, X5R	TDK	C2012X5R0J226M
C2 Input Capacitor	No Load		
C3 Output Capacitor	10 μF , 25 V, X5R	TDK	C3216X5R1E106M
C4 Output Capacitor	No Load		
C5 Comp Capacitor	2200 pF	TDK	C1608X5R1H222K
C6	2.2 μF 16 V	TDK	C2012X5R1C225K
D1, Catch Diode	0.4 V _f Schottky 1 A, 20 V _R	ST	STPS120M
L1	15 μH 1.5 A	Coilcraft	MSS5131-153ML
L2	15 μH 1.5 A	Coilcraft	MSS5131-153ML
R1	10.2 k Ω , 1%	Vishay	CRCW06031002F
R2	16.5 k Ω , 1%	Vishay	CRCW06031652F
R3	100 k Ω , 1%	Vishay	CRCW06031003F

8.2.14 LM2735X SOT-23 LED Design Example 14

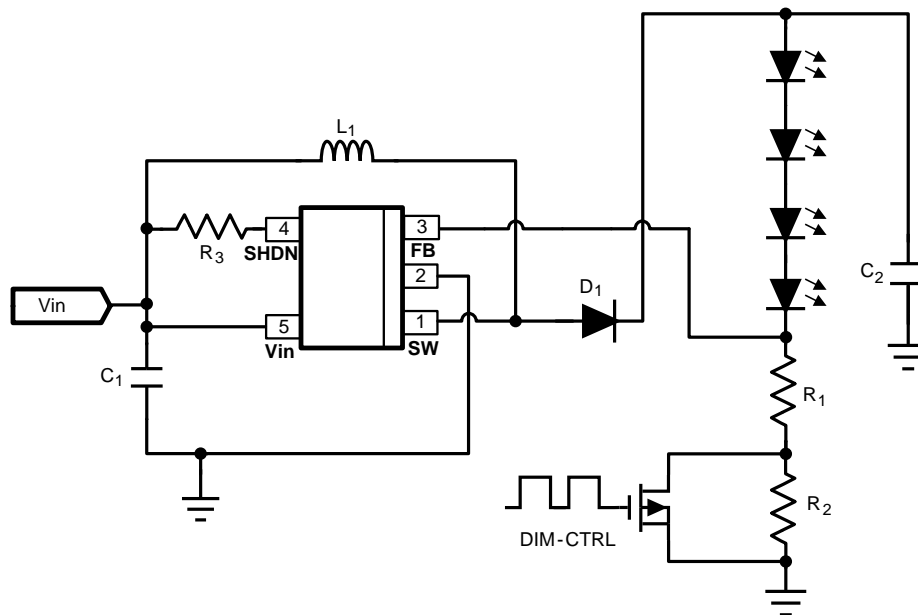
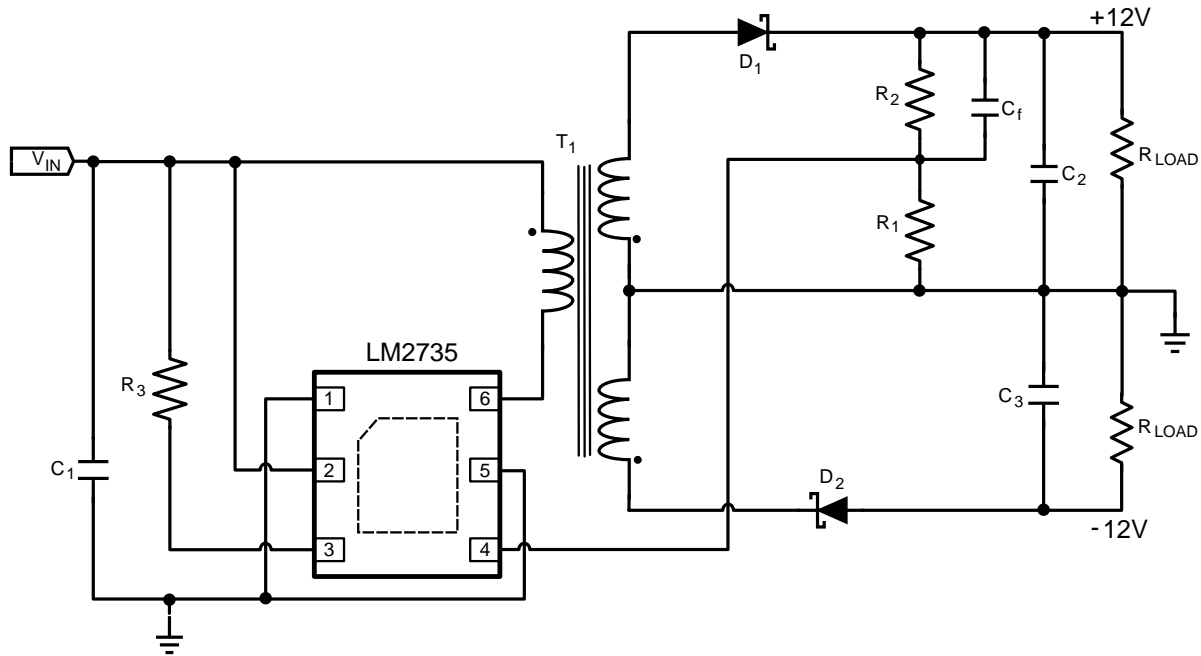

Figure 35. LM2735X (1.6 MHz): $V_{IN} = 2.7\text{ V} - 5\text{ V}$, $V_{OUT} = 20\text{ V}$ at 50 mA

PART ID	PART VALUE	MANUFACTURER	PART NUMBER
U1	2.1-A Boost Regulator	TI	LM2735XMF
C1 Input Capacitor	22 μF , 6.3 V, X5R	TDK	C2012X5R0J226M
C2 Output Capacitor	4.7 μF , 25 V, X5R	TDK	C3216JB1E475K
D1, Catch Diode	0.4 V_f Schottky 500 mA, 30 V_R	Vishay	MBR0530
L1	15 μH 1.5 A	Coilcraft	MSS5131-153ML
R1	25.5 Ω , 1%	Vishay	CRCW080525R5F
R2	100 Ω , 1%	Vishay	CRCW08051000F
R3	100 k Ω , 1%	Vishay	CRCW06031003F

8.2.15 LM2735Y WSON FlyBack Design Example 15

Figure 36. LM2735Y (520 kHz): $V_{IN} = 5\text{ V}$, $V_{OUT} = \pm 12\text{ V}$ 150 mA

PART ID	PART VALUE	MANUFACTURER	PART NUMBER
U1	2.1-A Boost Regulator	TI	LM2735YSD
C1 Input Capacitor	22 μF , 6.3 V, X5R	TDK	C2012X5R0J226M
C2 Output Capacitor	10 μF , 25 V, X5R	TDK	C3216X5R1E106M
C3 Output Capacitor	10 μF , 25 V, X5R	TDK	C3216X5R1E106M
Cf Comp Capacitor	330 pF	TDK	C1608X5R1H331K
D1, D2 Catch Diode	0.4 V_f Schottky 500 mA, 30 V_R	Vishay	MBR0530
T1			
R1	10.0 k Ω , 1%	Vishay	CRCW06031002F
R2	86.6 k Ω , 1%	Vishay	CRCW06038662F
R3	100 k Ω , 1%	Vishay	CRCW06031003F

LM2735

SNVS485I – JUNE 2007 – REVISED SEPTEMBER 2018

www.ti.com

8.2.16 LM2735X SOT-23 LED Design Example 16 $V_{RAIL} > 5.5\text{ V}$ Application

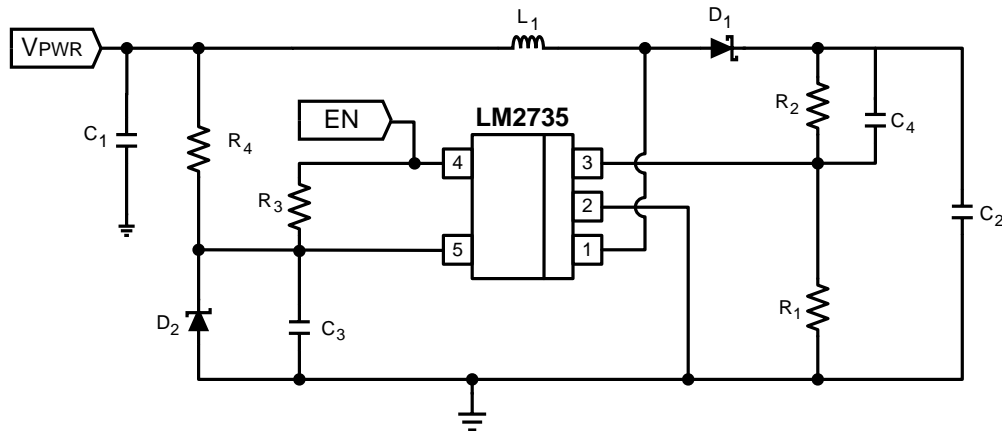

Figure 37. LM2735X (1.6 MHz): $V_{PWR} = 9\text{ V}$, $V_{OUT} = 12\text{ V}$ at 500 mA

PART ID	PART VALUE	MANUFACTURER	PART NUMBER
U1	2.1-A Boost Regulator	TI	LM2735XMF
C1, Input Capacitor	10 μF , 6.3 V, X5R	TDK	C2012X5R0J106K
C2, Output Capacitor	10 μF , 25 V, X5R	TDK	C3216X5R1E106M
C3 V_{IN} Cap	0.1 μF , 6.3 V, X5R	TDK	C2012X5R0J104K
C4 Comp Capacitor	1000 pF	TDK	C1608X5R1H102K
D1, Catch Diode	0.4 V_f Schottky 1 A, 20 V_R	ST	STPS120M
D2	3.3-V Zener, SOT-23	Diodes Inc	BZX84C3V3
L1	6.8 μH 2 A	Coilcraft	DO1813H-682ML
R1	10.0 k Ω , 1%	Vishay	CRCW08051002F
R2	86.6 k Ω , 1%	Vishay	CRCW08058662F
R3	100 k Ω , 1%	Vishay	CRCW06031003F
R4	499 Ω , 1%	Vishay	CRCW06034991F

8.2.17 LM2735X SOT-23 LED Design Example 17 Two-Input Voltage Rail Application

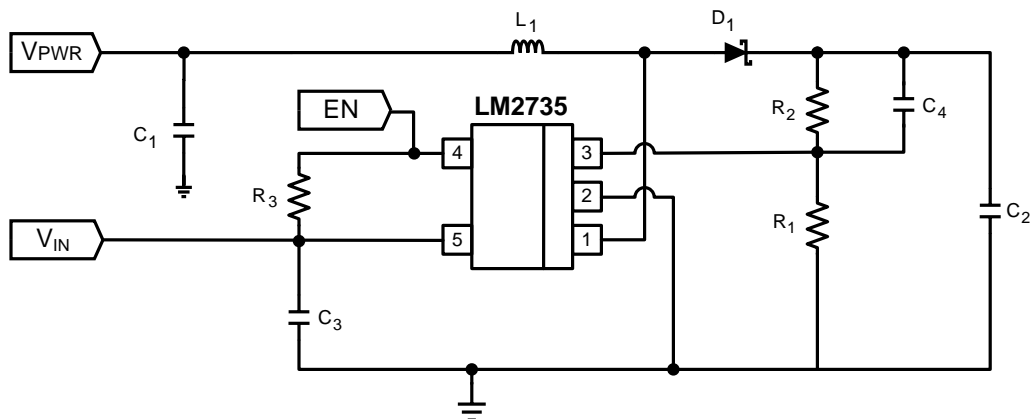

Figure 38. LM2735X (1.6 MHz): $V_{PWR} = 9\text{ V}$ in = 2.7 V - 5.5 V, $V_{OUT} = 12\text{ V}$ at 500 mA

PART ID	PART VALUE	MANUFACTURER	PART NUMBER
U1	2.1-A Boost Regulator	TI	LM2735XMF
C1, Input Capacitor	10 μF , 6.3 V, X5R	TDK	C2012X5R0J106K
C2, Output Capacitor	10 μF , 25 V, X5R	TDK	C3216X5R1E106M
C3 V_{IN} Capacitor	0.1 μF , 6.3 V, X5R	TDK	C2012X5R0J104K
C4 Comp Capacitor	1000 pF	TDK	C1608X5R1H102K
D1, Catch Diode	0.4 V_f Schottky 1 A, 20 V_R	ST	STPS120M
L1	6.8 μH 2 A	Coilcraft	DO1813H-682ML
R1	10.0 k Ω , 1%	Vishay	CRCW08051002F
R2	86.6 k Ω , 1%	Vishay	CRCW08058662F
R3	100 k Ω , 1%	Vishay	CRCW06031003F

Substituting I_{L1} into I_{L2}

$$I_{L2} = \frac{V_O}{R} \tag{20}$$

The average inductor current of L2 is the average output load.

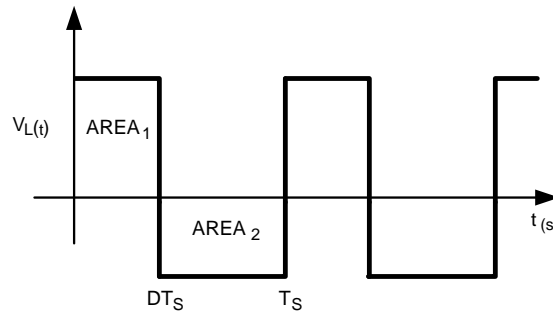

Figure 40. Inductor Volt-Sec Balance Waveform

Applying Charge balance on C1:

$$V_{C1} = \frac{D'(V_o)}{D} \tag{21}$$

Since there are no DC voltages across either inductor, and capacitor C6 is connected to V_{in} through L1 at one end, or to ground through L2 on the other end, we can say that

$$V_{C1} = V_{IN} \tag{22}$$

Therefore:

$$V_{IN} = \frac{D'(V_o)}{D} \tag{23}$$

This verifies the original conversion ratio equation.

It is important to remember that the internal switch current is equal to I_{L1} and I_{L2} . During the D interval. Design the converter so that the minimum specified peak switch current limit (2.1 A) is not exceeded.

8.2.18.1.3 Steady State Analysis With Loss Elements

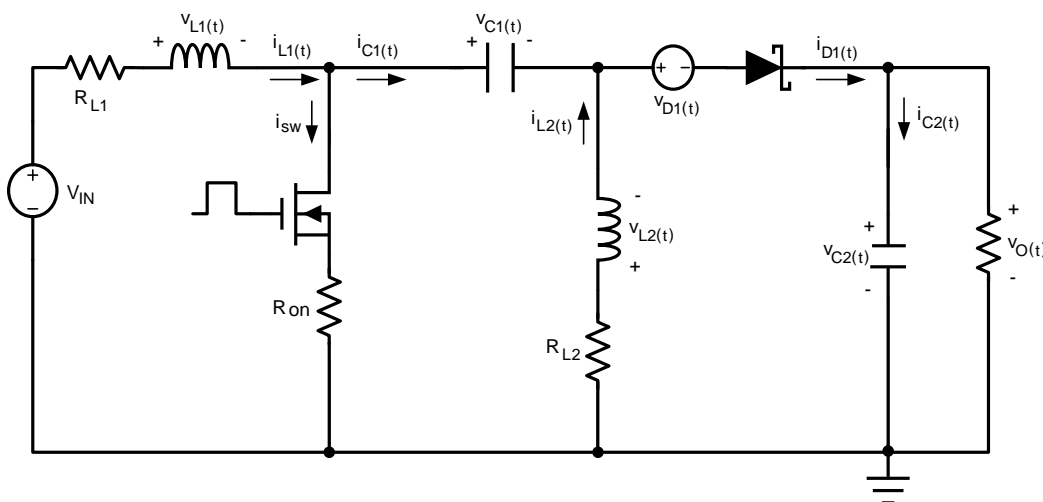

Using inductor volt-second balance & capacitor charge balance, the following equations are derived:

$$I_{L2} = \left(\frac{V_O}{R} \right)$$

and

$$I_{L1} = \left(\frac{V_O}{R} \right) \times \left(\frac{D}{D'} \right) \tag{24}$$

$$\frac{V_O}{V_{IN}} = \left(\frac{D}{D'} \right) \left(\frac{1}{\left(1 + \frac{V_D}{V_O} + \frac{R_{L2}}{R} \right) + \left(\frac{D}{D'^2} \right) \left(\frac{R_{ON}}{R} \right) + \left(\frac{D^2}{D'^2} \right) \left(\frac{R_{L1}}{R} \right)} \right) \tag{25}$$

Therefore:

$$\eta = \left(\frac{1}{\left(1 + \frac{V_D}{V_O} + \frac{R_{L2}}{R} \right) + \left(\frac{D}{D'^2} \right) \left(\frac{R_{ON}}{R} \right) + \left(\frac{D^2}{D'^2} \right) \left(\frac{R_{L1}}{R} \right)} \right) \tag{26}$$

One can see that all variables are known except for the duty cycle (D). A quadratic equation is needed to solve for D. A less accurate method of determining the duty cycle is to assume efficiency, and calculate the duty cycle.

$$\frac{V_O}{V_{IN}} = \left(\frac{D}{1 - D} \right) \times \eta \tag{27}$$

$$D = \left(\frac{V_O}{(V_{IN} \times \eta) + V_O} \right) \tag{28}$$

V _{in}	2.7V	V _{in}	3.3V	V _{in}	5V
V _o	3.1V	V _o	3.1V	V _o	3.1V
I _{in}	770 mA	I _{in}	600 mA	I _{in}	375 mA
I _o	500 mA	I _o	500 mA	I _o	500 mA
η	75%	η	80%	η	83%

Figure 41. Efficiencies for Typical SEPIC Application

9 Power Supply Recommendations

The LM2735 device is designed to operate from an input voltage supply range from 2.7 V to 5.5 V. This input supply should be able to withstand the maximum input current and maintain a voltage above 2.7 V. In case where input supply is located farther away (more than a few inches) from the device, additional bulk capacitance may be required in addition to the ceramic bypass capacitors.

10 Layout

10.1 Layout Guidelines

When planning layout, there are a few things to consider when trying to achieve a clean, regulated output. The most important consideration when completing a boost converter layout is the close coupling of the GND connections of the C_{OUT} capacitor and the LM2735 PGND pin. The GND ends should be close to one another and be connected to the GND plane with at least two through-holes. There should be a continuous ground plane on the bottom layer of a two-layer board except under the switching node island. The FB pin is a high impedance node and care should be taken to make the FB trace short to avoid noise pickup and inaccurate regulation. The feedback resistors should be placed as close as possible to the IC, with the AGND of R1 placed as close as possible to the GND (pin 5 for the WSON) of the IC. The V_{OUT} trace to R2 should be routed away from the inductor and any other traces that are switching. High AC currents flow through the V_{IN} , SW and V_{OUT} traces, so they should be as short and wide as possible. However, making the traces wide increases radiated noise, so the designer must make this trade-off. Radiated noise can be decreased by choosing a shielded inductor. The remaining components should also be placed as close as possible to the IC. See Application Note *AN-1229 SIMPLE SWITCHER® PCB Layout Guidelines (SNVA054)* for further considerations and the LM2735 demo board as an example of a 4-layer layout.

Below is an example of a good thermal and electrical PCB design. This is very similar to our LM2735 demonstration boards that are obtainable through the TI website. The demonstration board consists of a 2-layer PCB with a common input and output voltage application. Most of the routing is on the top layer, with the bottom layer consisting of a large ground plane. The placement of the external components satisfies the electrical considerations, and the thermal performance has been improved by adding thermal vias and a top layer *Dog-Bone*.

10.1.1 WSON Package

The LM2735 packaged in the 6-pin WSON:

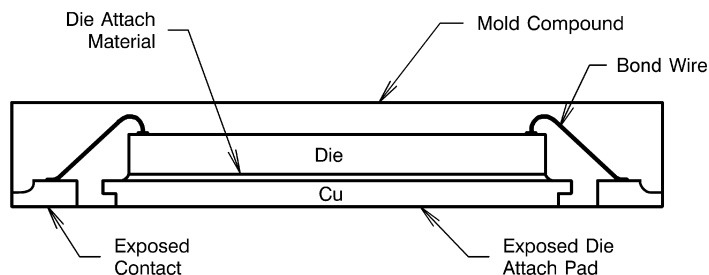

Figure 42. Internal WSON Connection

For certain high power applications, the PCB land may be modified to a *dog bone* shape (see Figure 43). Increasing the size of ground plane, and adding thermal vias can reduce the $R_{\theta JA}$ for the application.

Layout Guidelines (continued)

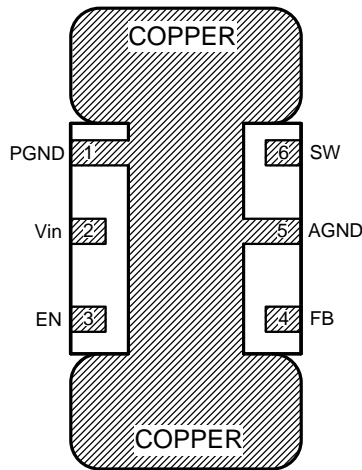

Figure 43. PCB Dog Bone Layout

10.2 Layout Examples

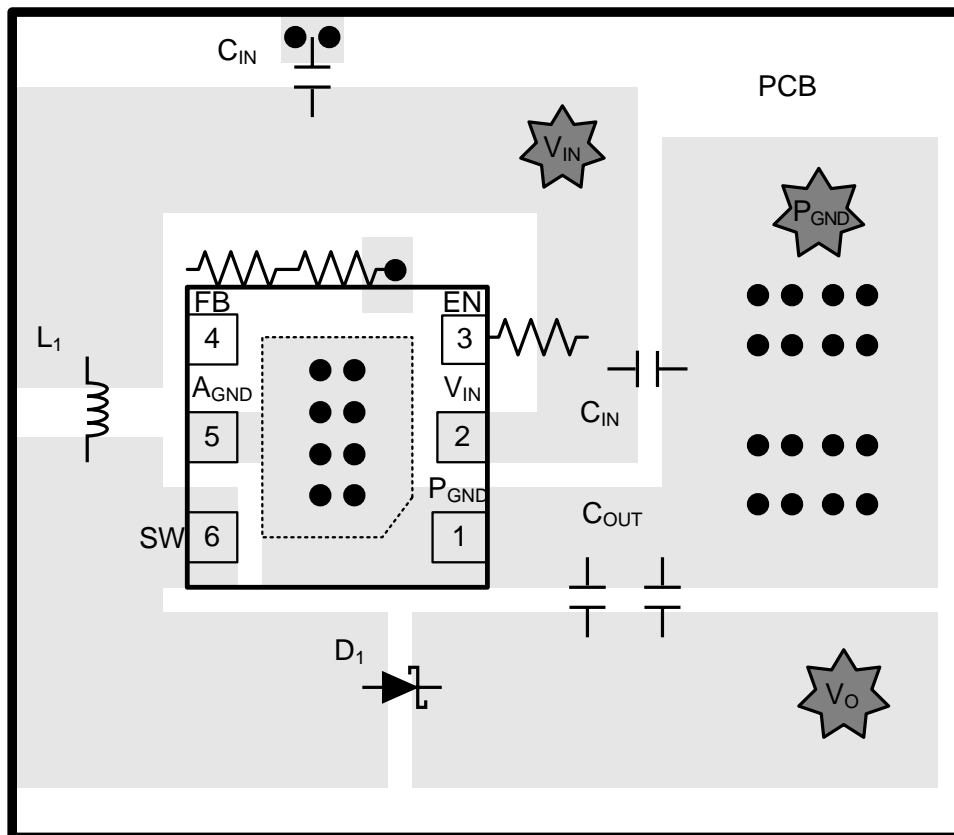

Figure 44. Example of Proper PCB Layout

Layout Examples (continued)

The layout guidelines described for the LM2735 Boost-Converter are applicable to the SEPIC Converter. Figure 45 shows a proper PCB layout for a SEPIC Converter.

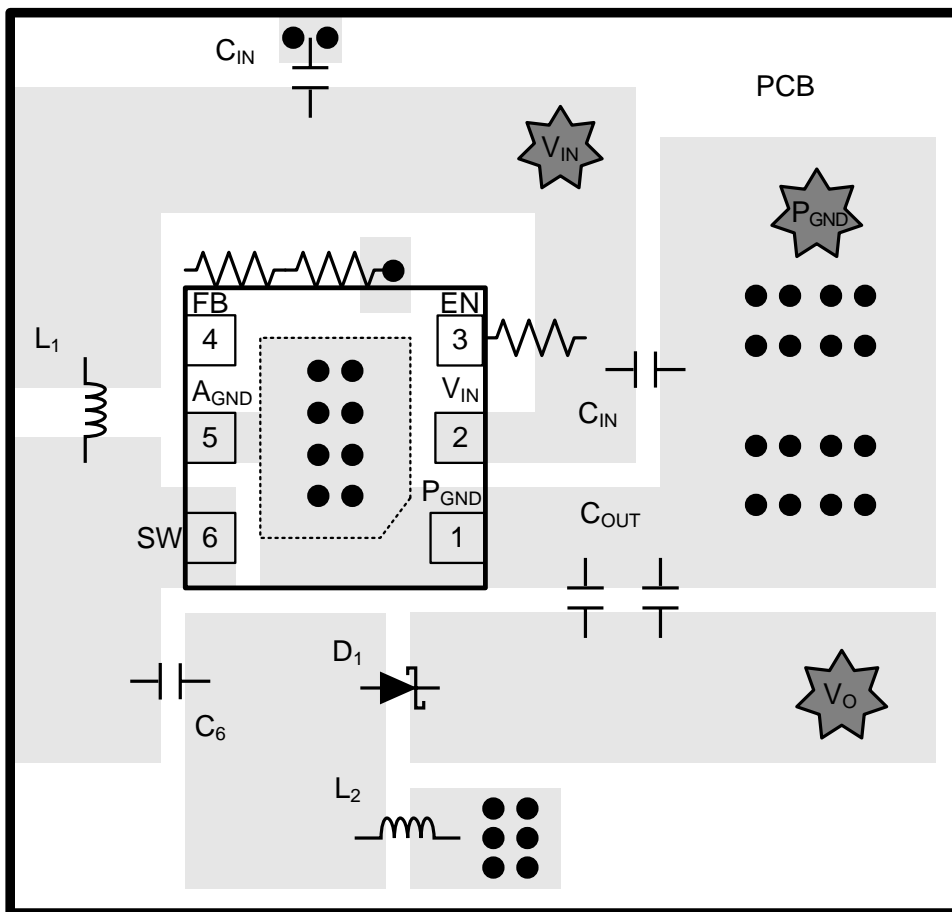

Figure 45. SEPIC PCB Layout

10.3 Thermal Considerations

When designing for thermal performance, one must consider many variables:

- **Ambient Temperature:** The surrounding maximum air temperature is fairly explanatory. As the temperature increases, the junction temperature will increase. This may not be linear though. As the surrounding air temperature increases, resistances of semiconductors, wires and traces increase. This will decrease the efficiency of the application, and more power will be converted into heat, and will increase the silicon junction temperatures further.
- **Forced Airflow:** Forced air can drastically reduce the device junction temperature. Air flow reduces the hot spots within a design. Warm airflow is often much better than a lower ambient temperature with no airflow.
- **External Components:** Choose components that are efficient, and you can reduce the mutual heating between devices.

Thermal Considerations (continued)

10.3.1 Definitions

Heat energy is transferred from regions of high temperature to regions of low temperature through three basic mechanisms: radiation, conduction and convection.

Radiation Electromagnetic transfer of heat between masses at different temperatures.

Conduction Transfer of heat through a solid medium.

Convection Transfer of heat through the medium of a fluid; typically air.

Conduction & Convection will be the dominant heat transfer mechanism in most applications.

R_{θJC} Thermal impedance from silicon junction to device case temperature.

R_{θJA} Thermal impedance from silicon junction to ambient air temperature.

C_{θJC} Thermal Delay from silicon junction to device case temperature.

C_{θCA} Thermal Delay from device case to ambient air temperature.

R_{θJA} & R_{θJC} These two symbols represent thermal impedances, and most data sheets contain associated values for these two symbols. The units of measurement are °C/Watt.

R_{θJA} is the sum of smaller thermal impedances (see [Figure 46](#)). The capacitors represent delays that are present from the time that power and its associated heat is increased or decreased from steady state in one medium until the time that the heat increase or decrease reaches steady state on the another medium.

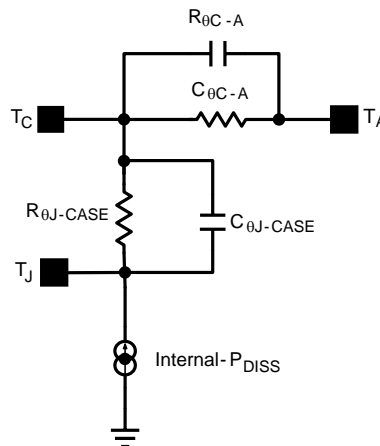

Figure 46. Simplified Thermal Impedance Model

The datasheet values for these symbols are given so that one might compare the thermal performance of one package against another. In order to achieve a comparison between packages, all other variables must be held constant in the comparison (PCB size, copper weight, thermal vias, power dissipation, V_{IN} , V_{OUT} , Load Current, and so forth). This does shed light on the package performance, but it would be a mistake to use these values to calculate the actual junction temperature in your application.

$$R_{\theta JA} = \frac{T_J - T_A}{P_{\text{Dissipation}}} \quad (29)$$

We will talk more about calculating the variables of this equation later, and how to eventually calculate a proper junction temperature with relative certainty. For now we need to define the process of calculating the junction temperature and clarify some common misconceptions.

Thermal Considerations (continued)

$R_{\theta JA}$ [Variables]:

- Input voltage, output voltage, output current, R_{DSon} .
- Ambient temperature and air flow.
- Internal and external components power dissipation.
- Package thermal limitations.
- PCB variables (copper weight, thermal vias, layers component placement).

It is incorrect to assume that the top case temperature is the proper temperature when calculating $R_{\theta JC}$ value. The $R_{\theta JC}$ value represents the thermal impedance of all six sides of a package, not just the top side. This document refers to a thermal impedance called $R_{\psi JC}$. $R_{\psi JC}$ represents a thermal impedance associated with just the top case temperature. This allows the user to calculate the junction temperature with a thermal sensor connected to the top case.

10.3.2 PCB Design With Thermal Performance in Mind

The PCB design is a very important step in the thermal design procedure. The LM2735 is available in three package options (5-pin SOT-23, 8-pin MSOP-PowerPAD, and 6-pin WSON). The options are electrically the same, but difference between the packages is size and thermal performance. The WSON and MSOP-PowerPAD have thermal Die Attach Pads (DAP) attached to the bottom of the packages, and are therefore capable of dissipating more heat than the SOT-23 package. It is important that the correct package for the application is chosen. A detailed thermal design procedure has been included in this data sheet. This procedure will help determine which package is correct, and common applications will be analyzed.

There is one significant thermal PCB layout design consideration that contradicts a proper electrical PCB layout design consideration. This contradiction is the placement of external components that dissipate heat. The greatest external heat contributor is the external Schottky diode. It would be ideal to be able to separate by distance the LM2735 from the Schottky diode, and thereby reducing the mutual heating effect, however, this will create electrical performance issues. It is important to keep the LM2735, the output capacitor, and Schottky diode physically close to each other (see [Figure 44](#)). The electrical design considerations outweigh the thermal considerations. Other factors that influence thermal performance are thermal vias, copper weight, and number of board layers.

10.3.3 LM2735 Thermal Models

Heat is dissipated from the LM2735 and other devices. The external loss elements include the Schottky diode, inductor, and loads. All loss elements will mutually increase the heat on the PCB, and therefore increase each other's temperatures.

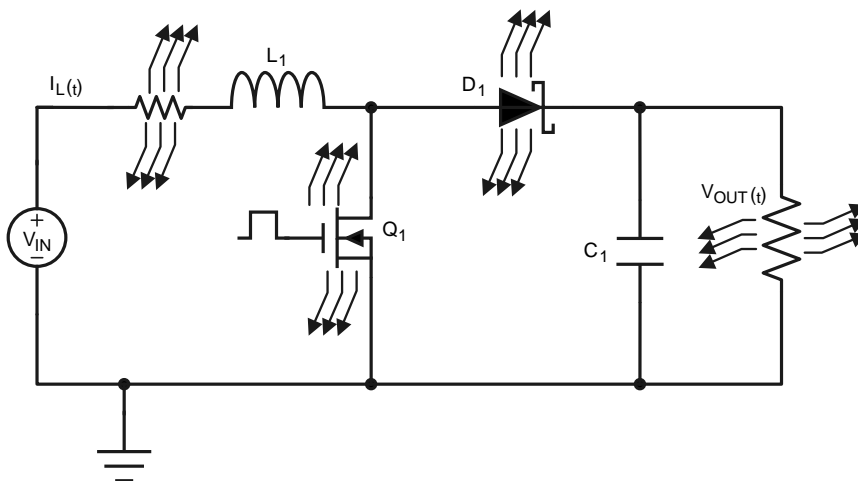

Figure 47. Thermal Schematic

Thermal Considerations (continued)

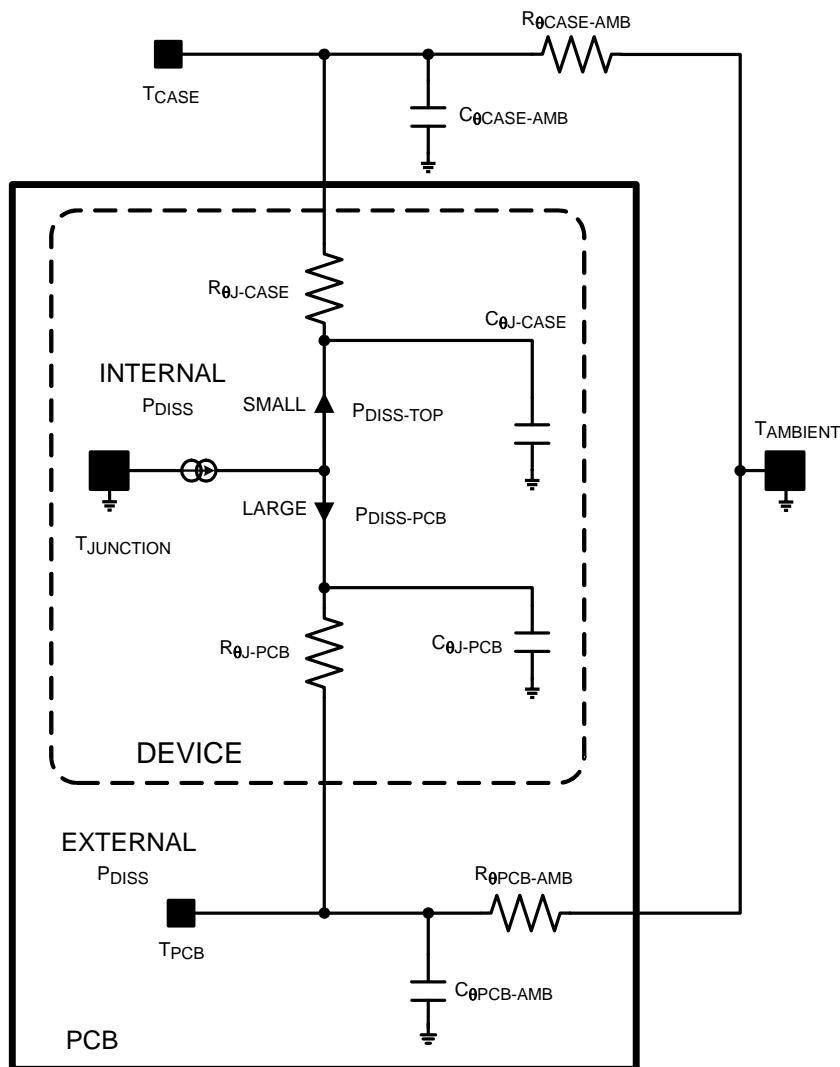

Figure 48. Associated Thermal Model

10.3.4 Calculating Efficiency, and Junction Temperature

The complete LM2735 DC-DC converter efficiency (η) can be calculated in the following manner.

$$\eta = \frac{P_{OUT}}{P_{IN}}$$

or

$$\eta = \frac{P_{OUT}}{P_{OUT} + P_{LOSS}} \tag{30}$$

Power loss (P_{LOSS}) is the sum of two types of losses in the converter, switching and conduction. Conduction losses usually dominate at higher output loads, where as switching losses remain relatively fixed and dominate at lower output loads.

Losses in the LM2735 device:

$$P_{LOSS} = P_{COND} + P_{SW} + P_Q \tag{31}$$

Thermal Considerations (continued)

Conversion ratio of the boost converter with conduction loss elements inserted:

$$\frac{V_{OUT}}{V_{IN}} = \frac{1}{D'} \left(1 - \frac{D' \times V_D}{V_{IN}} \right) \left(\frac{1}{1 + \frac{R_{DCR} + (D \times R_{DSON})}{D'^2 R_{OUT}}} \right) \quad (32)$$

If the loss elements are reduced to zero, the conversion ratio simplifies to:

$$\frac{V_{OUT}}{V_{IN}} = \frac{1}{D'} \quad (33)$$

And this is known:

$$\frac{V_{OUT}}{V_{IN}} = \frac{\eta}{D'} \quad (34)$$

Therefore:

$$\eta = D' \frac{V_{OUT}}{V_{IN}} = \left(\frac{1 - \frac{D' \times V_D}{V_{IN}}}{1 + \frac{R_{DCR} + (D \times R_{DSON})}{D'^2 R_{OUT}}} \right) \quad (35)$$

Calculations for determining the most significant power losses are discussed below. Other losses totaling less than 2% are not discussed.

A simple efficiency calculation that takes into account the conduction losses is shown below:

$$\eta \approx \left(\frac{1 - \frac{D' \times V_D}{V_{IN}}}{1 + \frac{R_{DCR} + (D \times R_{DSON})}{D'^2 R_{OUT}}} \right) \quad (36)$$

The diode, NMOS switch, and inductor DCR losses are included in this calculation. Setting any loss element to zero will simplify the equation.

V_D is the forward voltage drop across the Schottky diode. It can be obtained from the manufacturer's *Electrical Characteristics* section of the data sheet.

The conduction losses in the diode are calculated as follows:

$$P_{DIODE} = V_D \times I_O \quad (37)$$

Depending on the duty cycle, this can be the single most significant power loss in the circuit. Care should be taken to choose a diode that has a low forward voltage drop. Another concern with diode selection is reverse leakage current. Depending on the ambient temperature and the reverse voltage across the diode, the current being drawn from the output to the NMOS switch during time D could be significant, this may increase losses internal to the LM2735 and reduce the overall efficiency of the application. See the data sheets of the Schottky diode manufacturer for reverse leakage specifications; and, typical applications within this data sheet for diode selections.

Another significant external power loss is the conduction loss in the input inductor. The power loss within the inductor can be simplified to:

$$P_{IND} = I_{IN}^2 R_{DCR} \quad (38)$$

$$P_{IND} = \left(\frac{I_O^2 R_{DCR}}{D'} \right) \quad (39)$$

Thermal Considerations (continued)

The LM2735 conduction loss is mainly associated with the internal NFET:

$$P_{\text{COND-NFET}} = I_{\text{SW-rms}}^2 \times R_{\text{DSON}} \times D \quad (40)$$

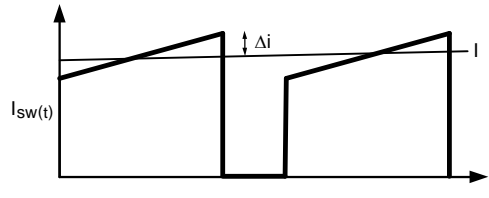

Figure 49. LM2735 Switch Current

$$I_{\text{SW-rms}} = I_{\text{IND}} \sqrt{D} \times \sqrt{1 + \frac{1}{3} \left(\frac{\Delta i}{I_{\text{IND}}} \right)^2} \approx I_{\text{IND}} \sqrt{D}$$

$$P_{\text{IND}} = I_{\text{IN}}^2 \times R_{\text{IND-DCR}}$$

(small ripple approximation) (41)

$$P_{\text{COND-NFET}} = I_{\text{IN}}^2 \times R_{\text{DSON}} \times D \quad (42)$$

$$P_{\text{COND-NFET}} = \left(\frac{I_{\text{O}}}{D} \right)^2 \times R_{\text{DSON}} \times D \quad (43)$$

The value for should be equal to the resistance at the junction temperature you wish to analyze. As an example, at 125°C and $V_{\text{IN}} = 5 \text{ V}$, $R_{\text{DSON}} = 250 \text{ m}\Omega$ (see [Typical Characteristics](#) for value).

Switching losses are also associated with the internal NMOS switch. They occur during the switch on and off transition periods, where voltages and currents overlap resulting in power loss.

The simplest means to determine this loss is to empirically measuring the rise and fall times (10% to 90%) of the switch at the switch node:

$$P_{\text{SWR}} = 1/2(V_{\text{OUT}} \times I_{\text{IN}} \times F_{\text{SW}} \times T_{\text{RISE}}) \quad (44)$$

$$P_{\text{SWF}} = 1/2(V_{\text{OUT}} \times I_{\text{IN}} \times F_{\text{SW}} \times T_{\text{FALL}}) \quad (45)$$

$$P_{\text{SW}} = P_{\text{SWR}} + P_{\text{SWF}} \quad (46)$$

Table 2. Typical Switch-Node Rise and Fall Times

V_{IN}	V_{OUT}	T_{RISE}	T_{FALL}
3 V	5 V	6 nS	4 nS
5 V	12 V	6 nS	5 nS
3 V	12 V	7 nS	5 nS
5 V	18 V	7 nS	5 nS

Quiescent Power Losses:

I_{Q} is the quiescent operating current, and is typically around 4 mA.

$$P_{\text{Q}} = I_{\text{Q}} \times V_{\text{IN}} \quad (47)$$

10.3.4.1 Example Efficiency Calculation
Table 3. Operating Conditions

PARAMETER	VALUE
V _{IN}	5 V
V _{OUT}	12 V
I _{OUT}	500 mA
V _D	0.4 V
F _{SW}	1.60 MHz
I _Q	4 mA
T _{RISE}	6 nS
T _{FALL}	5 nS
R _{DSON}	250 mΩ
R _{DCR}	50 mΩ
D	0.64
I _{IN}	1.4 A

$$\Sigma P_{\text{COND}} + P_{\text{SW}} + P_{\text{DIODE}} + P_{\text{IND}} + P_{\text{Q}} = P_{\text{LOSS}} \quad (48)$$

Quiescent Power Losses:

$$P_{\text{Q}} = I_{\text{Q}} \times V_{\text{IN}} = 20 \text{ mW} \quad (49)$$

Switching Power Losses:

$$P_{\text{SWR}} = 1/2(V_{\text{OUT}} \times I_{\text{IN}} \times F_{\text{SW}} \times T_{\text{RISE}}) \approx 6 \text{ ns} \approx 80 \text{ mW} \quad (50)$$

$$P_{\text{SWF}} = 1/2(V_{\text{OUT}} \times I_{\text{IN}} \times F_{\text{SW}} \times T_{\text{FALL}}) \approx 5 \text{ ns} \approx 70 \text{ mW} \quad (51)$$

$$P_{\text{SW}} = P_{\text{SWR}} + P_{\text{SWF}} = 150 \text{ mW} \quad (52)$$

Internal NFET Power Losses:

$$R_{\text{DSON}} = 250 \text{ m}\Omega \quad (53)$$

$$P_{\text{CONDUCTION}} = I_{\text{IN}}^2 \times D \times R_{\text{DSON}} \times 305 \text{ mW} \quad (54)$$

Diode Losses:

$$V_{\text{D}} = 0.45 \text{ V} \quad (55)$$

$$P_{\text{DIODE}} = V_{\text{D}} \times I_{\text{IN}}(1-D) = 236 \text{ mW} \quad (56)$$

Inductor Power Losses:

$$R_{\text{DCR}} = 75 \text{ m}\Omega \quad (57)$$

$$P_{\text{IND}} = I_{\text{IN}}^2 \times R_{\text{DCR}} = 145 \text{ mW} \quad (58)$$

Total Power Losses are:

Table 4. Power Loss Tabulation

PARAMETER	VALUE	PARAMETER	VALUE
V _{IN}	5 V		
V _{OUT}	12 V		
I _{OUT}	500 mA	POUT	6 W
V _D	0.4 V	PDIODE	236 mW
F _{SW}	1.6 MHz		
T _{RISE}	6 nS	PSWR	80 mW
T _{FALL}	5 nS	PSWF	70 mW
I _Q	4 mA	PQ	20 mW
R _{DSon}	250 mΩ	PCOND	305 mW
R _{DCR}	75 mΩ	PIND	145 mW
D	0.623		
η	86%	PLOSS	856 mW

$$P_{\text{INTERNAL}} = P_{\text{COND}} + P_{\text{SW}} = 475 \text{ mW} \quad (59)$$

10.3.5 Calculating R_{θJA} and R_{ψJC}

$$R_{\theta\text{JA}} = \frac{T_{\text{J}} - T_{\text{A}}}{P_{\text{Dissipation}}}$$

and

$$R_{\psi\text{JC}} = \frac{T_{\text{J}} - T_{\text{CASE}}}{P_{\text{Dissipation}}} \quad (60)$$

Now the internal power dissipation is known, and the junction temperature is attempted to be kept at or below 125°C. The next step is to calculate the value for R_{θJA} and/or R_{ψJC}. This is actually very simple to accomplish, and necessary if marginality is a possibility in regards to thermals or determining what package option is correct.

The LM2735 has a thermal shutdown comparator. When the silicon reaches a temperature of 160°C, the device shuts down until the temperature reduces to 150°C. Knowing this, the R_{θJA} or the R_{ψJC} of a specific application can be calculated. Because the junction-to-top case thermal impedance is much lower than the thermal impedance of junction to ambient air, the error in calculating R_{ψJC} is lower than for R_{θJA}. However, a small thermocouple will need to be attached onto the top case of the LM2735 to obtain the R_{ψJC} value.

Knowing the temperature of the silicon when the device shuts down allows three of the four variables to be known. Once the thermal impedance is calculated, work backwards with the junction temperature set to 125°C to determine what maximum ambient air temperature keeps the silicon below the 125°C temperature.

10.3.5.1 Procedure

Place the application into a thermal chamber. Sufficient power will need to be dissipated in the device so that a good thermal impedance value may be obtained.

Raise the ambient air temperature until the device goes into thermal shutdown. Record the temperatures of the ambient air and/or the top case temperature of the LM2735. Calculate the thermal impedances.

10.3.5.2 Example From Previous Calculations

$P_{\text{Dissipation}} = 475 \text{ mW}$

$T_A \text{ at Shutdown} = 139^\circ\text{C}$

$T_{\text{Case-Top}} \text{ at Shutdown} = 155^\circ\text{C}$

$$R_{\theta\text{JA}} = \frac{T_J - T_A}{P_{\text{Dissipation}}} : R_{\Psi\text{JC}} = \frac{T_J - T_{\text{Case-Top}}}{P_{\text{Dissipation}}} \tag{61}$$

$R_{\theta\text{JA}} \text{ WSON} = 55^\circ\text{C/W}$

$R_{\Psi\text{JC}} \text{ WSON} = 21^\circ\text{C/W}$

WSON & MSOP-PowerPAD typical applications will produce $R_{\theta\text{JA}}$ numbers in the range of 50°C/W to 65°C/W , and $R_{\Psi\text{JC}}$ will vary from 18°C/W to 28°C/W . These values are for PCB's with two and four layer boards with 0.5-oz copper, and 4 to 6 thermal vias to bottom side ground plane under the DAP.

For 5-pin SOT-23 package typical applications, $R_{\theta\text{JA}}$ numbers will range from 80°C/W to 110°C/W , and $R_{\Psi\text{JC}}$ will vary from 50°C/W to 65°C/W . These values are for PCBs with 2- and 4-layer boards with 0.5-oz copper, with 2 to 4 thermal vias from GND pin to bottom layer.

The following is a good rule of thumb for typical thermal impedances, and an ambient temperature maximum of 75°C : if the design requires more than 400 mW internal to the LM2735 be dissipated, or there is 750 mW of total power loss in the application, TI recommends using the 6-pin WSON or the 8-pin MSOP-PowerPAD package.

NOTE

To use these procedures, it is important to dissipate an amount of power within the device that will indicate a true thermal impedance value. If a very small internal dissipated value is used, it can be determined that the thermal impedance calculated is abnormally high, and subject to error. The graph below shows the nonlinear relationship of internal power dissipation vs $R_{\theta\text{JA}}$.

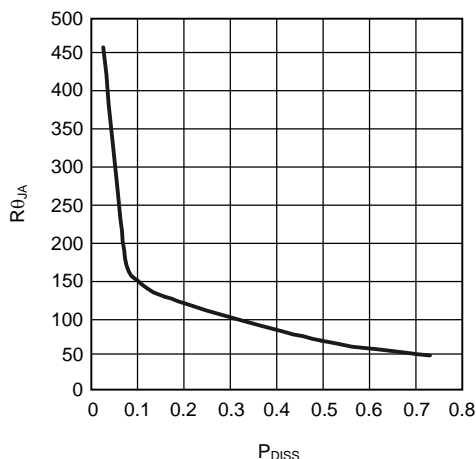

Figure 50. $R_{\theta\text{JA}}$ vs Internal Dissipation for the WSON and MSOP-PowerPAD Package

11 Device and Documentation Support

11.1 Device Support

11.1.1 Third-Party Products Disclaimer

TI'S PUBLICATION OF INFORMATION REGARDING THIRD-PARTY PRODUCTS OR SERVICES DOES NOT CONSTITUTE AN ENDORSEMENT REGARDING THE SUITABILITY OF SUCH PRODUCTS OR SERVICES OR A WARRANTY, REPRESENTATION OR ENDORSEMENT OF SUCH PRODUCTS OR SERVICES, EITHER ALONE OR IN COMBINATION WITH ANY TI PRODUCT OR SERVICE.

11.1.2 Development Support

11.1.2.1 Custom Design With WEBENCH® Tools

[Click here](#) to create a custom design using the LM2735 device with the WEBENCH® Power Designer.

1. Start by entering the input voltage (V_{IN}), output voltage (V_{OUT}), and output current (I_{OUT}) requirements.
2. Optimize the design for key parameters such as efficiency, footprint, and cost using the optimizer dial.
3. Compare the generated design with other possible solutions from Texas Instruments.

The WEBENCH Power Designer provides a customized schematic along with a list of materials with real-time pricing and component availability.

In most cases, these actions are available:

- Run electrical simulations to see important waveforms and circuit performance
- Run thermal simulations to understand board thermal performance
- Export customized schematic and layout into popular CAD formats
- Print PDF reports for the design, and share the design with colleagues

Get more information about WEBENCH tools at www.ti.com/WEBENCH.

11.2 Documentation Support

11.2.1 Related Documentation

For related documentation, see the following:

AN-1229 SIMPLE SWITCHER® PCB Layout Guidelines, [SNVA054](#)

11.3 Community Resources

The following links connect to TI community resources. Linked contents are provided "AS IS" by the respective contributors. They do not constitute TI specifications and do not necessarily reflect TI's views; see TI's [Terms of Use](#).

TI E2E™ Online Community *TI's Engineer-to-Engineer (E2E) Community*. Created to foster collaboration among engineers. At e2e.ti.com, you can ask questions, share knowledge, explore ideas and help solve problems with fellow engineers.

Design Support *TI's Design Support* Quickly find helpful E2E forums along with design support tools and contact information for technical support.

11.4 Trademarks

PowerPAD, E2E are trademarks of Texas Instruments.
 WEBENCH is a registered trademark of Texas Instruments.
 All other trademarks are the property of their respective owners.

11.5 Electrostatic Discharge Caution



These devices have limited built-in ESD protection. The leads should be shorted together or the device placed in conductive foam during storage or handling to prevent electrostatic damage to the MOS gates.

11.6 Glossary

[SLYZ022](#) — *TI Glossary*.

This glossary lists and explains terms, acronyms, and definitions.

12 Mechanical, Packaging, and Orderable Information

The following pages include mechanical, packaging, and orderable information. This information is the most current data available for the designated devices. This data is subject to change without notice and revision of this document. For browser-based versions of this data sheet, refer to the left-hand navigation.

PACKAGING INFORMATION

Orderable Device	Status (1)	Package Type	Package Drawing	Pins	Package Qty	Eco Plan (2)	Lead/Ball Finish (6)	MSL Peak Temp (3)	Op Temp (°C)	Device Marking (4/5)	Samples
LM2735XMF/NOPB	ACTIVE	SOT-23	DBV	5	1000	Green (RoHS & no Sb/Br)	CU SN	Level-1-260C-UNLIM	-40 to 125	SLEB	Samples
LM2735XMF/NOPB	ACTIVE	SOT-23	DBV	5	3000	Green (RoHS & no Sb/Br)	CU SN	Level-1-260C-UNLIM	-40 to 125	SLEB	Samples
LM2735XMY/NOPB	ACTIVE	MSOP-PowerPAD	DGN	8	1000	Green (RoHS & no Sb/Br)	CU SN	Level-1-260C-UNLIM	-40 to 125	SRJB	Samples
LM2735XSD/NOPB	ACTIVE	WSON	NGG	6	1000	Green (RoHS & no Sb/Br)	CU SN	Level-1-260C-UNLIM	-40 to 125	2735X	Samples
LM2735XSDX/NOPB	ACTIVE	WSON	NGG	6	4500	Green (RoHS & no Sb/Br)	CU SN	Level-1-260C-UNLIM	-40 to 125	2735X	Samples
LM2735YMF/NOPB	ACTIVE	SOT-23	DBV	5	1000	Green (RoHS & no Sb/Br)	CU SN	Level-1-260C-UNLIM	-40 to 125	SLFB	Samples
LM2735YMF/NOPB	ACTIVE	SOT-23	DBV	5	3000	Green (RoHS & no Sb/Br)	CU SN	Level-1-260C-UNLIM	-40 to 125	SLFB	Samples
LM2735YMY/NOPB	ACTIVE	MSOP-PowerPAD	DGN	8	1000	Green (RoHS & no Sb/Br)	CU SN	Level-1-260C-UNLIM	-40 to 125	SRKB	Samples
LM2735YSD/NOPB	ACTIVE	WSON	NGG	6	1000	Green (RoHS & no Sb/Br)	CU SN	Level-1-260C-UNLIM	-40 to 125	2735Y	Samples
LM2735YSDX/NOPB	ACTIVE	WSON	NGG	6	4500	Green (RoHS & no Sb/Br)	CU SN	Level-1-260C-UNLIM	-40 to 125	2735Y	Samples

(1) The marketing status values are defined as follows:

ACTIVE: Product device recommended for new designs.

LIFEBUY: TI has announced that the device will be discontinued, and a lifetime-buy period is in effect.

NRND: Not recommended for new designs. Device is in production to support existing customers, but TI does not recommend using this part in a new design.

PREVIEW: Device has been announced but is not in production. Samples may or may not be available.

OBSOLETE: TI has discontinued the production of the device.

(2) **RoHS:** TI defines "RoHS" to mean semiconductor products that are compliant with the current EU RoHS requirements for all 10 RoHS substances, including the requirement that RoHS substance do not exceed 0.1% by weight in homogeneous materials. Where designed to be soldered at high temperatures, "RoHS" products are suitable for use in specified lead-free processes. TI may reference these types of products as "Pb-Free".

RoHS Exempt: TI defines "RoHS Exempt" to mean products that contain lead but are compliant with EU RoHS pursuant to a specific EU RoHS exemption.

Green: TI defines "Green" to mean the content of Chlorine (Cl) and Bromine (Br) based flame retardants meet JS709B low halogen requirements of <=1000ppm threshold. Antimony trioxide based flame retardants must also meet the <=1000ppm threshold requirement.

(3) MSL, Peak Temp. - The Moisture Sensitivity Level rating according to the JEDEC industry standard classifications, and peak solder temperature.

(4) There may be additional marking, which relates to the logo, the lot trace code information, or the environmental category on the device.

(5) Multiple Device Markings will be inside parentheses. Only one Device Marking contained in parentheses and separated by a "~" will appear on a device. If a line is indented then it is a continuation of the previous line and the two combined represent the entire Device Marking for that device.

(6) Lead/Ball Finish - Orderable Devices may have multiple material finish options. Finish options are separated by a vertical ruled line. Lead/Ball Finish values may wrap to two lines if the finish value exceeds the maximum column width.

Important Information and Disclaimer:The information provided on this page represents TI's knowledge and belief as of the date that it is provided. TI bases its knowledge and belief on information provided by third parties, and makes no representation or warranty as to the accuracy of such information. Efforts are underway to better integrate information from third parties. TI has taken and continues to take reasonable steps to provide representative and accurate information but may not have conducted destructive testing or chemical analysis on incoming materials and chemicals. TI and TI suppliers consider certain information to be proprietary, and thus CAS numbers and other limited information may not be available for release.

In no event shall TI's liability arising out of such information exceed the total purchase price of the TI part(s) at issue in this document sold by TI to Customer on an annual basis.

OTHER QUALIFIED VERSIONS OF LM2735 :

- Automotive: [LM2735-Q1](#)

NOTE: Qualified Version Definitions:

- Automotive - Q100 devices qualified for high-reliability automotive applications targeting zero defects

TAPE AND REEL INFORMATION



QUADRANT ASSIGNMENTS FOR PIN 1 ORIENTATION IN TAPE



*All dimensions are nominal

Device	Package Type	Package Drawing	Pins	SPQ	Reel Diameter (mm)	Reel Width W1 (mm)	A0 (mm)	B0 (mm)	K0 (mm)	P1 (mm)	W (mm)	Pin1 Quadrant
LM2735XMF/NOPB	SOT-23	DBV	5	1000	178.0	8.4	3.2	3.2	1.4	4.0	8.0	Q3
LM2735XMF/NOPB	SOT-23	DBV	5	3000	178.0	8.4	3.2	3.2	1.4	4.0	8.0	Q3
LM2735XMY/NOPB	MSOP-Power PAD	DGN	8	1000	178.0	12.4	5.3	3.4	1.4	8.0	12.0	Q1
LM2735XSD/NOPB	WSON	NGG	6	1000	178.0	12.4	3.3	3.3	1.0	8.0	12.0	Q1
LM2735XSD/NOPB	WSON	NGG	6	4500	330.0	12.4	3.3	3.3	1.0	8.0	12.0	Q1
LM2735YMF/NOPB	SOT-23	DBV	5	1000	178.0	8.4	3.2	3.2	1.4	4.0	8.0	Q3
LM2735YMF/NOPB	SOT-23	DBV	5	3000	178.0	8.4	3.2	3.2	1.4	4.0	8.0	Q3
LM2735YMY/NOPB	MSOP-Power PAD	DGN	8	1000	178.0	12.4	5.3	3.4	1.4	8.0	12.0	Q1
LM2735YSD/NOPB	WSON	NGG	6	1000	178.0	12.4	3.3	3.3	1.0	8.0	12.0	Q1
LM2735YSD/NOPB	WSON	NGG	6	4500	330.0	12.4	3.3	3.3	1.0	8.0	12.0	Q1

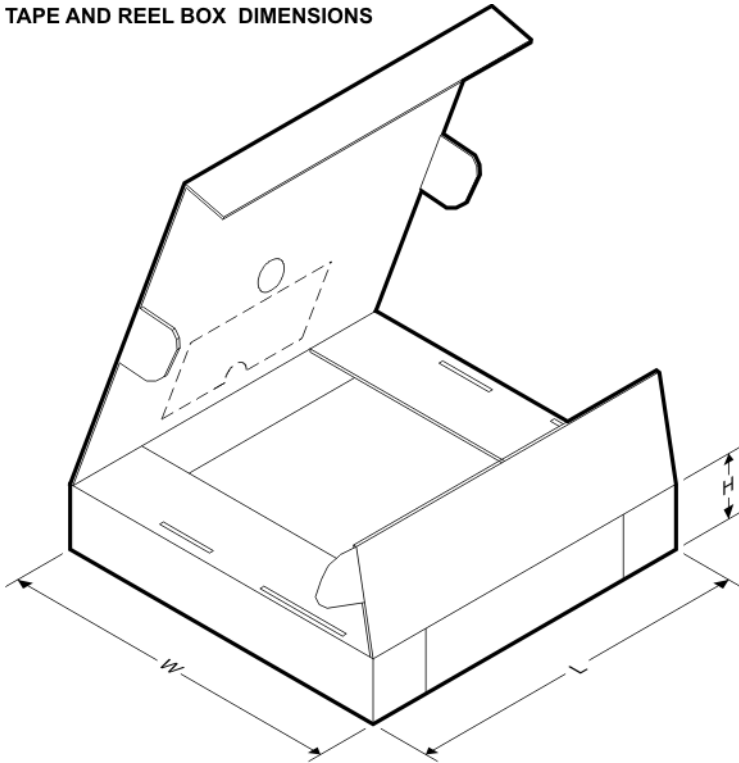
TAPE AND REEL BOX DIMENSIONS

*All dimensions are nominal

Device	Package Type	Package Drawing	Pins	SPQ	Length (mm)	Width (mm)	Height (mm)
LM2735XMF/NOPB	SOT-23	DBV	5	1000	210.0	185.0	35.0
LM2735XMFX/NOPB	SOT-23	DBV	5	3000	210.0	185.0	35.0
LM2735XMY/NOPB	MSOP-PowerPAD	DGN	8	1000	210.0	185.0	35.0
LM2735XSD/NOPB	WSON	NGG	6	1000	210.0	185.0	35.0
LM2735XSDX/NOPB	WSON	NGG	6	4500	367.0	367.0	35.0
LM2735YMF/NOPB	SOT-23	DBV	5	1000	210.0	185.0	35.0
LM2735YMFX/NOPB	SOT-23	DBV	5	3000	210.0	185.0	35.0
LM2735YMY/NOPB	MSOP-PowerPAD	DGN	8	1000	210.0	185.0	35.0
LM2735YSD/NOPB	WSON	NGG	6	1000	210.0	185.0	35.0
LM2735YSDX/NOPB	WSON	NGG	6	4500	367.0	367.0	35.0

NGG0006A

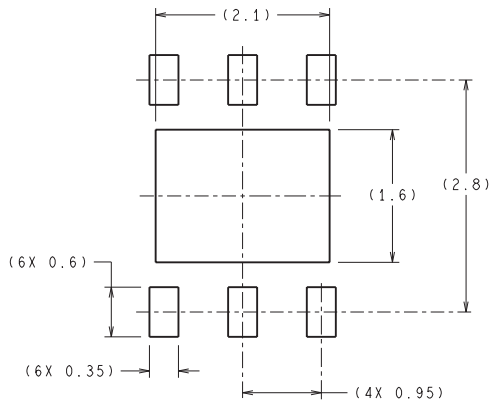

RECOMMENDED LAND PATTERN

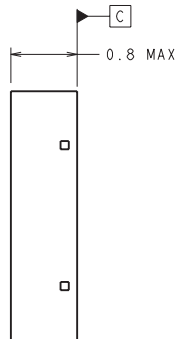
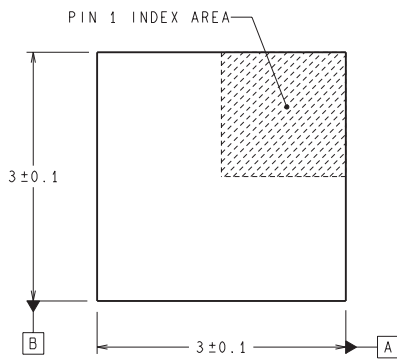

DIMENSIONS ARE IN MILLIMETERS
DIMENSION IN () FOR REFERENCE ONLY

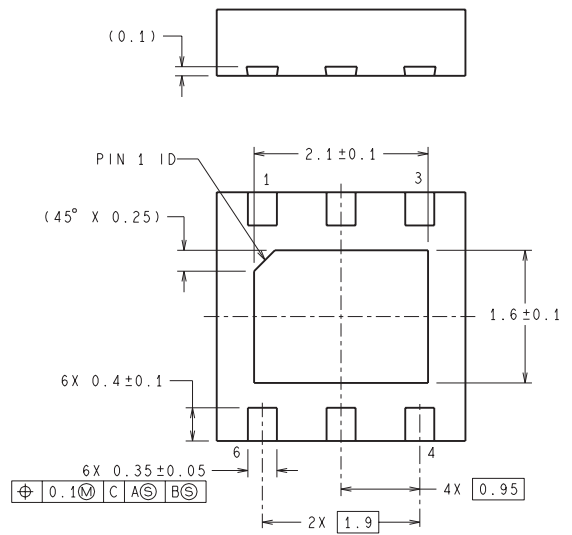

SDE06A (Rev A)

DBV0005A



PACKAGE OUTLINE

SOT-23 - 1.45 mm max height

SMALL OUTLINE TRANSISTOR

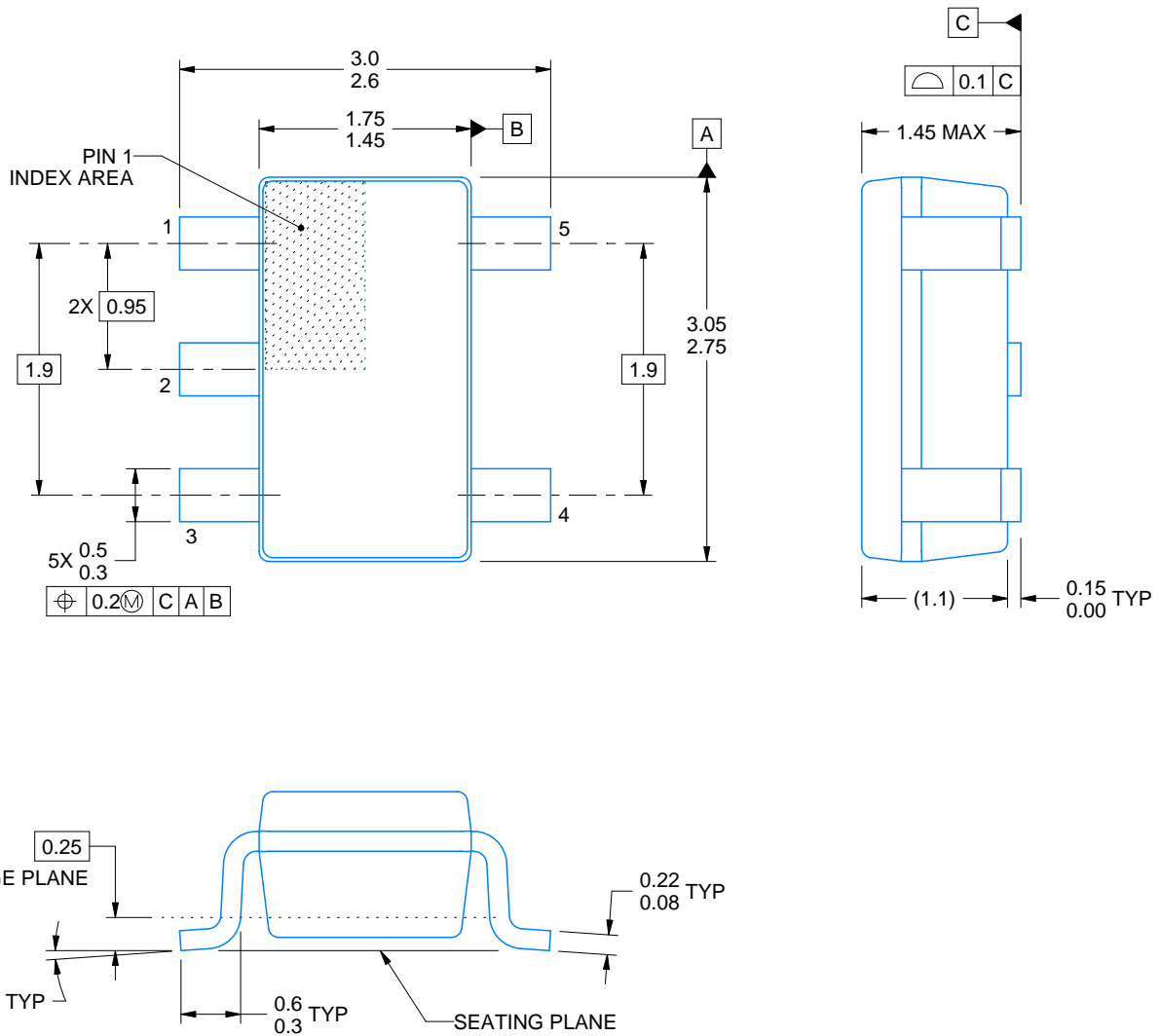

4214839/D 11/2018

NOTES:

1. All linear dimensions are in millimeters. Any dimensions in parenthesis are for reference only. Dimensioning and tolerancing per ASME Y14.5M.
2. This drawing is subject to change without notice.
3. Reference JEDEC MO-178.
4. Body dimensions do not include mold flash, protrusions, or gate burrs. Mold flash, protrusions, or gate burrs shall not exceed 0.15 mm per side.

EXAMPLE BOARD LAYOUT

DBV0005A

SOT-23 - 1.45 mm max height

SMALL OUTLINE TRANSISTOR



LAND PATTERN EXAMPLE
EXPOSED METAL SHOWN
SCALE:15X



SOLDER MASK DETAILS

4214839/D 11/2018

NOTES: (continued)

- 5. Publication IPC-7351 may have alternate designs.
- 6. Solder mask tolerances between and around signal pads can vary based on board fabrication site.

EXAMPLE STENCIL DESIGN

DBV0005A

SOT-23 - 1.45 mm max height

SMALL OUTLINE TRANSISTOR



SOLDER PASTE EXAMPLE
BASED ON 0.125 mm THICK STENCIL
SCALE:15X

4214839/D 11/2018

NOTES: (continued)

7. Laser cutting apertures with trapezoidal walls and rounded corners may offer better paste release. IPC-7525 may have alternate design recommendations.
8. Board assembly site may have different recommendations for stencil design.

DGN0008A

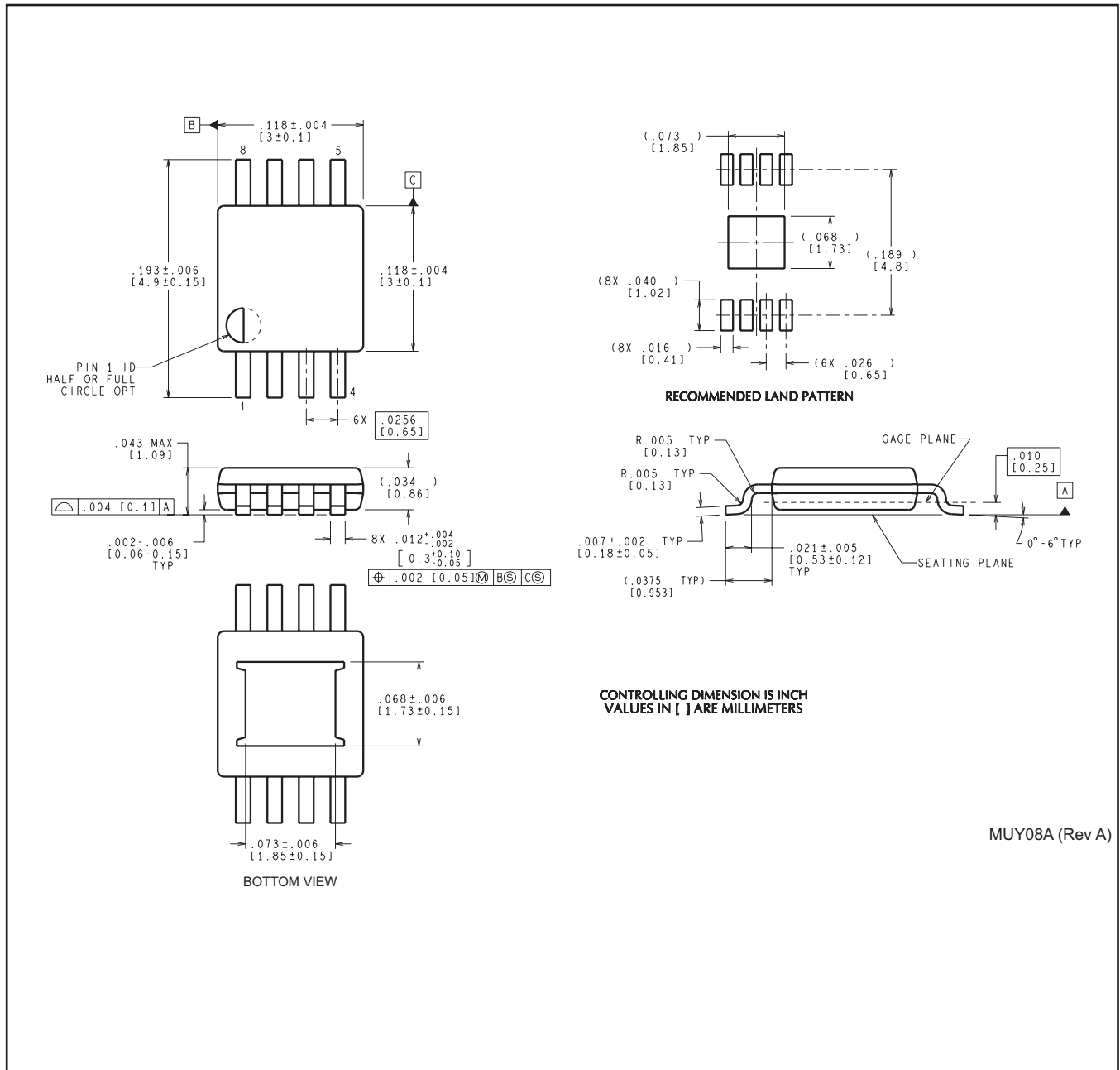

MUY08A (Rev A)

IMPORTANT NOTICE AND DISCLAIMER

TI PROVIDES TECHNICAL AND RELIABILITY DATA (INCLUDING DATASHEETS), DESIGN RESOURCES (INCLUDING REFERENCE DESIGNS), APPLICATION OR OTHER DESIGN ADVICE, WEB TOOLS, SAFETY INFORMATION, AND OTHER RESOURCES "AS IS" AND WITH ALL FAULTS, AND DISCLAIMS ALL WARRANTIES, EXPRESS AND IMPLIED, INCLUDING WITHOUT LIMITATION ANY IMPLIED WARRANTIES OF MERCHANTABILITY, FITNESS FOR A PARTICULAR PURPOSE OR NON-INFRINGEMENT OF THIRD PARTY INTELLECTUAL PROPERTY RIGHTS.

These resources are intended for skilled developers designing with TI products. You are solely responsible for (1) selecting the appropriate TI products for your application, (2) designing, validating and testing your application, and (3) ensuring your application meets applicable standards, and any other safety, security, or other requirements. These resources are subject to change without notice. TI grants you permission to use these resources only for development of an application that uses the TI products described in the resource. Other reproduction and display of these resources is prohibited. No license is granted to any other TI intellectual property right or to any third party intellectual property right. TI disclaims responsibility for, and you will fully indemnify TI and its representatives against, any claims, damages, costs, losses, and liabilities arising out of your use of these resources.

TI's products are provided subject to TI's Terms of Sale (www.ti.com/legal/termsofsale.html) or other applicable terms available either on ti.com or provided in conjunction with such TI products. TI's provision of these resources does not expand or otherwise alter TI's applicable warranties or warranty disclaimers for TI products.

Mailing Address: Texas Instruments, Post Office Box 655303, Dallas, Texas 75265
Copyright © 2019, Texas Instruments Incorporated

Looking for pricing, stock, or lifecycle information?

Click below to explore more details on WIN SOURCE:

 [View LM2735XMYEVAL on WIN SOURCE](#)

 [Texas Instruments](#) Information

Optimize Your Supply Chain with WIN SOURCE Solutions

-  Global Sourcing Solution
-  Obsolete Management
-  Cost Control Management
-  Shortage Management
-  Alternative Solution
-  Excess Inventory Management