

**LHF00L15**  
**Flash Memory**  
**32M (2Mb x 16)**  
(Model Number: LHF00L15)

Spec. Issue Date: June 16, 2004  
Spec No: EL163056A

---

SPEC No.	EL163056A
ISSUE:	Jun. 16, 2004

To; \_\_\_\_\_

## S P E C I F I C A T I O N S

Product Type 32 Mbit Flash Memory

### L H F 0 0 L 1 5

Model No. (LHF00L15)

If you have any objections, please contact us before issuing purchasing order.

\* This specifications contains 34 pages including the cover and appendix.

\* Refer to LHF00LXX series Appendix (FUM03802).

#### CUSTOMERS ACCEPTANCE

DATE: \_\_\_\_\_

BY: \_\_\_\_\_

PRESENTED

BY: Y. Hotta  
Y. Hotta  
Dept. General Manager

REVIEWED BY:

PREPARED BY:

\_\_\_\_\_ Sotano

Product Development Dept. I  
System-Flash Division  
Integrated Circuits Group  
SHARP CORPORATION

- Handle this document carefully for it contains material protected by international copyright law. Any reproduction, full or in part, of this material is prohibited without the express written permission of the company.
  - When using the products covered herein, please observe the conditions written herein and the precautions outlined in the following paragraphs. In no event shall the company be liable for any damages resulting from failure to strictly adhere to these conditions and precautions.
- (1) The products covered herein are designed and manufactured for the following application areas. When using the products covered herein for the equipment listed in Paragraph (2), even for the following application areas, be sure to observe the precautions given in Paragraph (2). Never use the products for the equipment listed in Paragraph (3).
- Office electronics
  - Instrumentation and measuring equipment
  - Machine tools
  - Audiovisual equipment
  - Home appliance
  - Communication equipment other than for trunk lines
- (2) Those contemplating using the products covered herein for the following equipment which demands high reliability, should first contact a sales representative of the company and then accept responsibility for incorporating into the design fail-safe operation, redundancy, and other appropriate measures for ensuring reliability and safety of the equipment and the overall system.
- Control and safety devices for airplanes, trains, automobiles, and other transportation equipment
  - Mainframe computers
  - Traffic control systems
  - Gas leak detectors and automatic cutoff devices
  - Rescue and security equipment
  - Other safety devices and safety equipment, etc.
- (3) Do not use the products covered herein for the following equipment which demands extremely high performance in terms of functionality, reliability, or accuracy.
- Aerospace equipment
  - Communications equipment for trunk lines
  - Control equipment for the nuclear power industry
  - Medical equipment related to life support, etc.
- (4) Please direct all queries and comments regarding the interpretation of the above three Paragraphs to a sales representative of the company.
- Please direct all queries regarding the products covered herein to a sales representative of the company.

## CONTENTS

	PAGE		PAGE
48-Lead TSOP (Normal Bend) Pinout .....	3	1 Electrical Specifications .....	14
Pin Descriptions.....	4	1.1 Absolute Maximum Ratings.....	14
Memory Map .....	5	1.2 Operating Conditions .....	14
Identifier Codes and OTP Address for Read Operation .....	6	1.2.1 Capacitance.....	15
OTP Block Address Map for OTP Program.....	7	1.2.2 AC Input/Output Test Conditions.....	15
Bus Operation .....	8	1.2.3 DC Characteristics.....	16
Command Definitions .....	9	1.2.4 AC Characteristics - Read-Only Operations.....	18
Functions of Block Lock and Block Lock-Down.....	11	1.2.5 AC Characteristics - Write Operations .....	20
Block Locking State Transitions upon Command Write.....	11	1.2.6 Reset Operations.....	22
Block Locking State Transitions upon WP#/ACC Transition .....	12	1.2.7 Block Erase, Full Chip Erase, Program and OTP Program Performance.	23
Status Register Definition.....	13	2 Related Document Information .....	24
		3 Package and packing specification.....	25

# LHF00L15

## 32Mbit (2Mbit×16)

### Flash MEMORY

- 32-M density with 16-bit I/O Interface
- Read Operation
  - 90ns
- Low Power Operation
  - 2.7V Read and Write Operations
  - Automatic Power Savings Mode reduces  $I_{CCR}$  in Static Mode
- Enhanced Code + Data Storage
  - 5 $\mu$ s Typical Erase/Program Suspends
- OTP (One Time Program) Block
  - 4-Word Factory-Programmed Area
  - 4-Word User-Programmable Area
- Operating Temperature -40°C to +85°C
- CMOS Process (P-type silicon substrate)
- Flexible Blocking Architecture
  - Eight 4-Kword Parameter Blocks
  - One 32-Kword Block
  - Thirty-one 64-Kword Blocks
  - Bottom Parameter Location
- Enhanced Data Protection Features
  - Individual Block Lock and Block Lock-Down with Zero-Latency
  - All blocks are locked at power-up or device reset.
  - Block Erase, Full Chip Erase, Word Program Lockout during Power Transitions
- Automated Erase/Program Algorithms
  - 3.0V Low-Power 10 $\mu$ s/Word (Typ.) Programming
  - 12.0V No Glue Logic 9 $\mu$ s/Word (Typ.) Production Programming and 0.8s Erase (Typ.)
- Cross-Compatible Command Support
  - Basic Command Set
  - Common Flash Interface (CFI)
- Extended Cycling Capability
  - Minimum 100,000 Block Erase Cycles
- 48-Lead TSOP (Normal Bend)
- ETOX<sup>TM</sup>\* Flash Technology
- Not designed or rated as radiation hardened

The product is a low power, high density, low cost, nonvolatile read/write storage solution for a wide range of applications. The product can operate at  $V_{CC}=2.7V-3.6V$ . Its low voltage operation capability greatly extends battery life for portable applications.

The memory array block architecture utilizes Enhanced Data Protection features, which provides maximum flexibility for safe nonvolatile code and data storage.

Special OTP (One Time Program) block provides an area to store permanent code such as an unique number.

\* ETOX is a trademark of Intel Corporation.

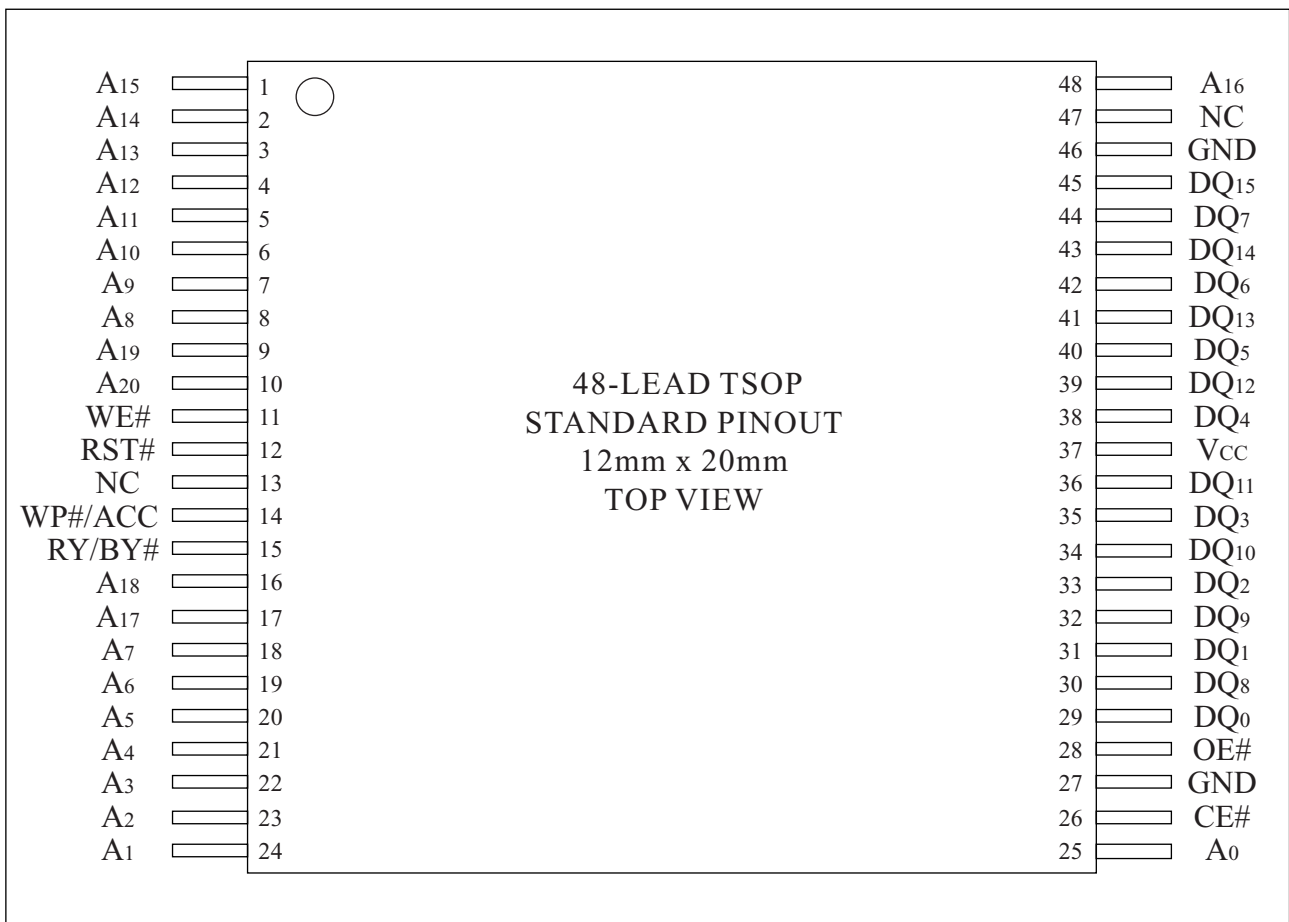

Figure 1. 48-Lead TSOP (Normal Bend) Pinout

Table 1. Pin Descriptions

Symbol	Type	Name and Function
A <sub>20</sub> -A <sub>0</sub>	INPUT	ADDRESS INPUTS: Inputs for addresses.
DQ <sub>15</sub> -DQ <sub>0</sub>	INPUT/ OUTPUT	DATA INPUTS/OUTPUTS: Inputs data and commands during CUI (Command User Interface) write cycles, outputs data during memory array, status register, query code, identifier code reads. Data pins float to high-impedance (High Z) when the chip or outputs are deselected. Data is internally latched during an erase or program cycle.
CE#	INPUT	CHIP ENABLE: Activates the device's control logic, input buffers, decoders and sense amplifiers. CE#-high (V <sub>IH</sub> ) deselected the device and reduces power consumption to standby levels.
RST#	INPUT	RESET: When low (V <sub>IL</sub> ), RST# resets internal automation and inhibits write operations which provides data protection. RST#-high (V <sub>IH</sub> ) enables normal operation. After power-up or reset mode, the device is automatically set to read array mode. RST# must be low during power-up/down.
OE#	INPUT	OUTPUT ENABLE: Gates the device's outputs during a read cycle.
WE#	INPUT	WRITE ENABLE: Controls writes to the CUI and array blocks. Addresses and data are latched on the rising edge of CE# or WE# (whichever goes high first).
WP#/ACC	INPUT/ SUPPLY	WRITE PROTECT: When WP#/ACC is V <sub>IL</sub> , locked-down blocks cannot be unlocked. Erase or program operation can be executed to the blocks which are not locked and not locked-down. When WP#/ACC is V <sub>IH</sub> , lock-down is disabled. Applying 12.0V±0.3V to WP#/ACC provides fast erasing or fast programming mode. In this mode, WP#/ACC is power supply pin. Applying 12.0V±0.3V to WP#/ACC during erase/program can only be done for a maximum of 1,000 cycles on each block. WP#/ACC may be connected to 12.0V±0.3V for a total of 80 hours maximum. Use of this pin at 12.0V±0.3V beyond these limits may reduce block cycling capability or cause permanent damage.
RY/BY#	OPEN DRAIN OUTPUT	READY/BUSY#: Indicates the status of the internal WSM (Write State Machine). When low, WSM is performing an internal operation (block erase, full chip erase, program or OTP program). RY/BY#-High Z indicates that the WSM is ready for new commands, block erase is suspended and program is inactive, program is suspended, or the device is in reset mode.
V <sub>CC</sub>	SUPPLY	DEVICE POWER SUPPLY (2.7V-3.6V): With V <sub>CC</sub> ≤V <sub>LKO</sub> , all write attempts to the flash memory are inhibited. Device operations at invalid V <sub>CC</sub> voltage (see DC Characteristics) produce spurious results and should not be attempted.
GND	SUPPLY	GROUND: Do not float any ground pins.
NC		NO CONNECT: Lead is not internally connected; it may be driven or floated.

[A<sub>20</sub>-A<sub>0</sub>]

1EFFFF	64-Kword Block 39
1F0000	64-Kword Block 38
1EFFFF	64-Kword Block 38
1E0000	64-Kword Block 37
1DFFFF	64-Kword Block 37
1D0000	64-Kword Block 36
1CFFFF	64-Kword Block 36
1C0000	64-Kword Block 35
1BFFFF	64-Kword Block 35
1B0000	64-Kword Block 34
1AFFFF	64-Kword Block 34
1A0000	64-Kword Block 33
19FFFF	64-Kword Block 33
190000	64-Kword Block 32
18FFFF	64-Kword Block 32
180000	64-Kword Block 31
17FFFF	64-Kword Block 31
170000	64-Kword Block 30
16FFFF	64-Kword Block 30
160000	64-Kword Block 29
15FFFF	64-Kword Block 29
150000	64-Kword Block 28
14FFFF	64-Kword Block 28
140000	64-Kword Block 27
13FFFF	64-Kword Block 27
130000	64-Kword Block 26
12FFFF	64-Kword Block 26
120000	64-Kword Block 25
11FFFF	64-Kword Block 25
110000	64-Kword Block 24
10FFFF	64-Kword Block 24
100000	64-Kword Block 23
0FFFFF	64-Kword Block 23
0F0000	64-Kword Block 22
0EFFFF	64-Kword Block 22
0E0000	64-Kword Block 21
0DFFFF	64-Kword Block 21
0D0000	64-Kword Block 20
0CFFFF	64-Kword Block 20
0C0000	64-Kword Block 19
0BFFFF	64-Kword Block 19
0B0000	64-Kword Block 18
0AFFFF	64-Kword Block 18
0A0000	64-Kword Block 17
09FFFF	64-Kword Block 17
090000	64-Kword Block 16
08FFFF	64-Kword Block 16
080000	64-Kword Block 15
07FFFF	64-Kword Block 15
070000	64-Kword Block 14
06FFFF	64-Kword Block 14
060000	64-Kword Block 13
05FFFF	64-Kword Block 13
050000	64-Kword Block 12
04FFFF	64-Kword Block 12
040000	64-Kword Block 11
03FFFF	64-Kword Block 11
030000	64-Kword Block 10
02FFFF	64-Kword Block 10
020000	64-Kword Block 9
01FFFF	64-Kword Block 9
010000	32-Kword Block 8
00FFFF	32-Kword Block 8
008000	4-Kword Block 7
007FFF	4-Kword Block 7
007000	4-Kword Block 6
006FFF	4-Kword Block 6
006000	4-Kword Block 5
005FFF	4-Kword Block 5
005000	4-Kword Block 4
004FFF	4-Kword Block 4
004000	4-Kword Block 3
003FFF	4-Kword Block 3
003000	4-Kword Block 2
002FFF	4-Kword Block 2
002000	4-Kword Block 1
001FFF	4-Kword Block 1
001000	4-Kword Block 0
000FFF	4-Kword Block 0
000000	4-Kword Block 0

Figure 2. Memory Map (Bottom Parameter)

Table 2. Identifier Codes and OTP Address for Read Operation

	Code	Address [A <sub>20</sub> -A <sub>0</sub> ]	Data [DQ <sub>15</sub> -DQ <sub>0</sub> ]	Notes
Manufacturer Code	Manufacturer Code	000000H	00B0H	
Device Code	Device Code	000001H	00A1H	
Block Lock Configuration Code	Block is Unlocked	Block Address + 2	DQ <sub>0</sub> = 0	1
	Block is Locked		DQ <sub>0</sub> = 1	1
	Block is not Locked-Down		DQ <sub>1</sub> = 0	1
	Block is Locked-Down		DQ <sub>1</sub> = 1	1
OTP	OTP Lock	000080H	OTP-LK	2
	OTP	000081-000088H	OTP	3

## NOTES:

1. Block Address = The beginning location of a block address. DQ<sub>15</sub>-DQ<sub>2</sub> are reserved for future implementation.
2. OTP-LK=OTP Block Lock configuration.
3. OTP=OTP Block data.

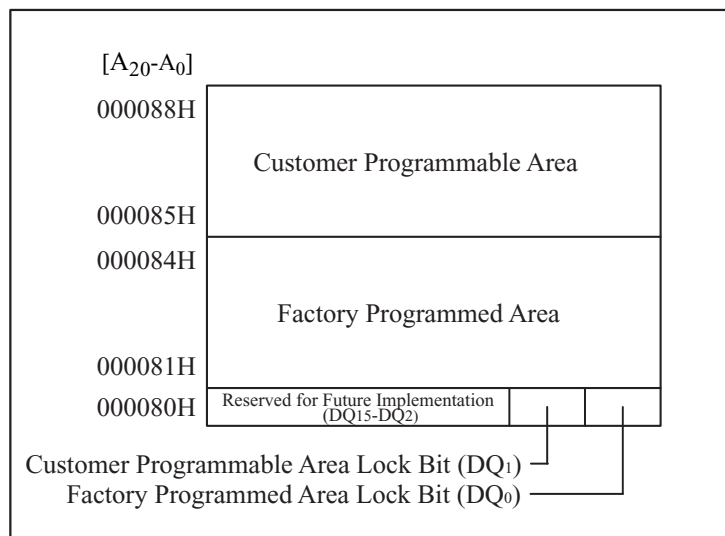

Figure 3. OTP Block Address Map for OTP Program  
(The area outside 80H~88H cannot be used.)

Table 3. Bus Operation<sup>(1,2)</sup>

Mode	Notes	RST#	CE#	OE#	WE#	Address	DQ <sub>15-0</sub>	RY/BY# <sup>(8)</sup>
Read Array	6	V <sub>IH</sub>	V <sub>IL</sub>	V <sub>IL</sub>	V <sub>IH</sub>	X	D <sub>OUT</sub>	High Z
Output Disable		V <sub>IH</sub>	V <sub>IL</sub>	V <sub>IH</sub>	V <sub>IH</sub>	X	High Z	X
Standby		V <sub>IH</sub>	V <sub>IH</sub>	X	X	X	High Z	X
Reset	3	V <sub>IL</sub>	X	X	X	X	High Z	High Z
Read Identifier Codes/OTP	6	V <sub>IH</sub>	V <sub>IL</sub>	V <sub>IL</sub>	V <sub>IH</sub>	See Table 2	See Table 2	High Z
Read Query	6,7	V <sub>IH</sub>	V <sub>IL</sub>	V <sub>IL</sub>	V <sub>IH</sub>	See Appendix	See Appendix	High Z
Read Status Register	6	V <sub>IH</sub>	V <sub>IL</sub>	V <sub>IL</sub>	V <sub>IH</sub>	X	D <sub>OUT</sub>	X
Write	4,5,6	V <sub>IH</sub>	V <sub>IL</sub>	V <sub>IH</sub>	V <sub>IL</sub>	X	D <sub>IN</sub>	X

## NOTES:

1. Refer to DC Characteristics for V<sub>IL</sub> or V<sub>IH</sub> voltages.
2. X can be V<sub>IL</sub> or V<sub>IH</sub> for control pins and addresses.
3. RST# at GND±0.2V ensures the lowest power consumption.
4. Command writes involving block erase, full chip erase, program or OTP program are reliably executed when V<sub>CC</sub>=2.7V-3.6V.
5. Refer to Table 4 for valid D<sub>IN</sub> during a write operation.
6. Never hold OE# low and WE# low at the same timing.
7. Refer to Appendix of LHF00LXX series for more information about query code.
8. RY/BY# is V<sub>OL</sub> when the WSM (Write State Machine) is executing internal block erase, full chip erase, program or OTP program algorithms. It is High Z during when the WSM is not busy, in block erase suspend mode (with program inactive), program suspend mode, or reset mode.

Table 4. Command Definitions<sup>(10)</sup>

Command	Bus Cycles Req'd	Notes	First Bus Cycle			Second Bus Cycle		
			Oper <sup>(1)</sup>	Addr <sup>(2)</sup>	Data	Oper <sup>(1)</sup>	Addr <sup>(2)</sup>	Data <sup>(3)</sup>
Read Array	1		Write	X	FFH			
Read Identifier Codes/OTP	≥ 2	4	Write	X	90H	Read	IA or OA	ID or OD
Read Query	≥ 2	4	Write	X	98H	Read	QA	QD
Read Status Register	2		Write	X	70H	Read	X	SRD
Clear Status Register	1		Write	X	50H			
Block Erase	2	5	Write	BA	20H	Write	BA	D0H
Full Chip Erase	2	5, 8	Write	X	30H	Write	X	D0H
Program	2	5,6	Write	WA	40H or 10H	Write	WA	WD
Block Erase and Program Suspend	1	7, 8	Write	X	B0H			
Block Erase and Program Resume	1	7, 8	Write	X	D0H			
Set Block Lock Bit	2		Write	BA	60H	Write	BA	01H
Clear Block Lock Bit	2	9	Write	BA	60H	Write	BA	D0H
Set Block Lock-down Bit	2		Write	BA	60H	Write	BA	2FH
OTP Program	2	8	Write	OA	C0H	Write	OA	OD

## NOTES:

- Bus operations are defined in Table 3.
- All addresses which are written at the first bus cycle should be the same as the addresses which are written at the second bus cycle.  
X=Any valid address within the device.  
IA=Identifier codes address (See Table 2).  
QA=Query codes address. Refer to Appendix of LHF00LXX series for details.  
BA=Address within the block being erased, set/cleared block lock bit or set block lock-down bit.  
WA=Address of memory location for the Program command.  
OA=Address of OTP block to be read or programmed (See Figure 3).
- ID=Data read from identifier codes. (See Table 2).  
QD=Data read from query database. Refer to Appendix of LHF00LXX series for details.  
SRD=Data read from status register. See Table 8 for a description of the status register bits.  
WD=Data to be programmed at location WA. Data is latched on the rising edge of WE# or CE# (whichever goes high first) during command write cycles.  
OD=Data within OTP block. Data is latched on the rising edge of WE# or CE# (whichever goes high first) during command write cycles.
- Following the Read Identifier Codes/OTP command, read operations access manufacturer code, device code, block lock configuration code and the data within OTP block (See Table 2).  
The Read Query command is available for reading CFI (Common Flash Interface) information.
- Block erase, full chip erase or program cannot be executed when the selected block is locked. Unlocked block can be erased or programmed when RST# is V<sub>IH</sub>.
- Either 40H or 10H are recognized by the CUI (Command User Interface) as the program setup.
- If the program operation and the erase operation are both suspended, the suspended program operation will be resumed first.
- Full chip erase and OTP program operations can not be suspended. The OTP Program command can not be accepted while the block erase operation is being suspended.

9. Following the Clear Block Lock Bit command, block which is not locked-down is unlocked when WP#/ACC is  $V_{IL}$ . When WP#/ACC is  $V_{IH}$ , lock-down bit is disabled and the selected block is unlocked regardless of lock-down configuration.
10. Commands other than those shown above are reserved by SHARP for future device implementations and should not be used.

Table 5. Functions of Block Lock<sup>(5)</sup> and Block Lock-Down

Current State					Erase/Program Allowed <sup>(2)</sup>
State	WP#/ACC	DQ <sub>1</sub> <sup>(1)</sup>	DQ <sub>0</sub> <sup>(1)</sup>	State Name	
[000]	0	0	0	Unlocked	Yes
[001] <sup>(3)</sup>	0	0	1	Locked	No
[011]	0	1	1	Locked-down	No
[100]	1	0	0	Unlocked	Yes
[101] <sup>(3)</sup>	1	0	1	Locked	No
[110] <sup>(4)</sup>	1	1	0	Lock-down Disable	Yes
[111]	1	1	1	Lock-down Disable	No

## NOTES:

1. DQ<sub>0</sub>=1: a block is locked; DQ<sub>0</sub>=0: a block is unlocked.  
DQ<sub>1</sub>=1: a block is locked-down; DQ<sub>1</sub>=0: a block is not locked-down.
2. Erase and program are general terms, respectively, to express: block erase, full chip erase and program operations.
3. At power-up or device reset, all blocks default to locked state and are not locked-down, that is, [001] (WP#/ACC=0) or [101] (WP#/ACC=1), regardless of the states before power-off or reset operation.
4. When WP#/ACC is driven to V<sub>IL</sub> in [110] state, the state changes to [011] and the blocks are automatically locked.
5. OTP (One Time Program) block has the lock function which is different from those described above.

Table 6. Block Locking State Transitions upon Command Write<sup>(4)</sup>

Current State				Result after Lock Command Written (Next State)		
State	WP#/ACC	DQ <sub>1</sub>	DQ <sub>0</sub>	Set Lock <sup>(1)</sup>	Clear Lock <sup>(1)</sup>	Set Lock-down <sup>(1)</sup>
[000]	0	0	0	[001]	No Change	[011] <sup>(2)</sup>
[001]	0	0	1	No Change <sup>(3)</sup>	[000]	[011]
[011]	0	1	1	No Change	No Change	No Change
[100]	1	0	0	[101]	No Change	[111] <sup>(2)</sup>
[101]	1	0	1	No Change	[100]	[111]
[110]	1	1	0	[111]	No Change	[111] <sup>(2)</sup>
[111]	1	1	1	No Change	[110]	No Change

## NOTES:

1. "Set Lock" means Set Block Lock Bit command, "Clear Lock" means Clear Block Lock Bit command and "Set Lock-down" means Set Block Lock-Down Bit command.
2. When the Set Block Lock-Down Bit command is written to the unlocked block (DQ<sub>0</sub>=0), the corresponding block is locked-down and automatically locked at the same time.
3. "No Change" means that the state remains unchanged after the command written.
4. In this state transitions table, assumes that WP#/ACC is not changed and fixed V<sub>IL</sub> or V<sub>IH</sub>.

Table 7. Block Locking State Transitions upon WP#/ACC Transition<sup>(4)</sup>

Previous State	Current State				Result after WP#/ACC Transition (Next State)	
	State	WP#/ACC	DQ <sub>1</sub>	DQ <sub>0</sub>	WP#/ACC=0→1 <sup>(1)</sup>	WP#/ACC=1→0 <sup>(1)</sup>
-	[000]	0	0	0	[100]	-
-	[001]	0	0	1	[101]	-
[110] <sup>(2)</sup>	[011]	0	1	1	[110]	-
Other than [110] <sup>(2)</sup>					[111]	-
-	[100]	1	0	0	-	[000]
-	[101]	1	0	1	-	[001]
-	[110]	1	1	0	-	[011] <sup>(3)</sup>
-	[111]	1	1	1	-	[011]

## NOTES:

1. "WP#/ACC=0→1" means that WP#/ACC is driven to V<sub>IH</sub> and "WP#/ACC=1→0" means that WP#/ACC is driven to V<sub>IL</sub>.
2. State transition from the current state [011] to the next state depends on the previous state.
3. When WP#/ACC is driven to V<sub>IL</sub> in [110] state, the state changes to [011] and the blocks are automatically locked.
4. In this state transitions table, assumes that lock configuration commands are not written in previous, current and next state.

Table 8. Status Register Definition

R	R	R	R	R	R	R	R
15	14	13	12	11	10	9	8
WSMS	BESS	EPS	EPS	WPACCS	PSS	DPS	R
7	6	5	4	3	2	1	0

<p>SR.15 - SR.8 = RESERVED FOR FUTURE ENHANCEMENTS (R)</p> <p>SR.7 = WRITE STATE MACHINE STATUS (WSMS) 1 = Ready 0 = Busy</p> <p>SR.6 = BLOCK ERASE SUSPEND STATUS (BESS) 1 = Block Erase Suspended 0 = Block Erase in Progress/Completed</p> <p>SR.5, SR.4 = ERASE, PROGRAM STATUS (EPS) SR.5=1 and SR.4=1: Command Sequence Error SR.5=1 or SR.4=1: Error in Block Erase, Full Chip Erase, Program or OTP Program SR.5=0 and SR.4=0: Successful Block Erase, Full Chip Erase, Program or OTP Program</p> <p>SR.3 = WP#/ACC STATUS (WPACCS) 1 = <math>V_{CC}+0.4V &lt; WP\#/ACC &lt; 11.7V</math> Detect, Operation Abort 0 = WP#/ACC OK</p> <p>SR.2 = PROGRAM SUSPEND STATUS (PSS) 1 = Program Suspended 0 = Program in Progress/Completed</p> <p>SR.1 = DEVICE PROTECT STATUS (DPS) 1 = Erase or Program Attempted on a Locked Block, Operation Abort 0 = Unlocked</p> <p>SR.0 = RESERVED FOR FUTURE ENHANCEMENTS (R)</p>	<p>NOTES:</p> <p>Status Register indicates the status of the WSM (Write State Machine).</p> <p>Check SR.7 or RY/BY# to determine block erase, full chip erase, program or OTP program completion. SR.6 - SR.1 are invalid while SR.7="0".</p> <p>If both SR.5 and SR.4 are "1"s after a block erase, full chip erase, program, set/clear block lock bit, set block lock-down bit attempt, an improper command sequence was entered.</p> <p>For the period of time required to check the status register in erase and program operation, refer to the specifications of block erase, full chip erase, program and OTP Program time.</p> <p>SR.3 does not provide a continuous indication of WP#/ACC level. The WSM interrogates and indicates the WP#/ACC level only after Block Erase, Full Chip Erase, Program or OTP Program command sequences. SR.3 is not guaranteed to report accurate feedback when <math>WP\#/ACC \neq V_{ACCH}</math>.</p> <p>SR.1 does not provide a continuous indication of block lock bit. The WSM interrogates the block lock bit only after Block Erase, Full Chip Erase, Program or OTP Program command sequences. It informs the system, depending on the attempted operation, if the block lock bit is set. Reading the block lock configuration codes after writing the Read Identifier Codes/OTP command indicates block lock bit status.</p> <p>SR.15 - SR.8 and SR.0 are reserved for future use and should be masked out when polling the status register.</p>
--	--

## 1 Electrical Specifications

### 1.1 Absolute Maximum Ratings \*

#### Operating Temperature

During Read, Erase and Program ... -40°C to +85°C <sup>(1)</sup>

#### Storage Temperature

During under Bias..... -40°C to +85°C

During non Bias..... -65°C to +125°C

#### Voltage On Any Pin (except V<sub>CC</sub> and WP#/ACC)

..... -0.5V to V<sub>CC</sub>+0.5V <sup>(2)</sup>

#### V<sub>CC</sub> Supply Voltage ..... -0.2V to +3.9V <sup>(2)</sup>

#### WP#/ACC Supply Voltage ..... -0.2V to +12.6V <sup>(2, 3, 4)</sup>

#### Output Short Circuit Current ..... 100mA <sup>(5)</sup>

**\*WARNING:** Stressing the device beyond the "Absolute Maximum Ratings" may cause permanent damage. These are stress ratings only. Operation beyond the "Operating Conditions" is not recommended and extended exposure beyond the "Operating Conditions" may affect device reliability.

#### NOTES:

- Operating temperature is for extended temperature product defined by this specification.
- All specified voltages are with respect to GND. Minimum DC voltage is -0.5V on input/output pins and -0.2V on V<sub>CC</sub> and WP#/ACC pins. During transitions, this level may undershoot to -2.0V for periods <20ns. Maximum DC voltage on input/output pins is V<sub>CC</sub>+0.5V which, during transitions, may overshoot to V<sub>CC</sub>+2.0V for periods <20ns.
- Maximum DC voltage on WP#/ACC may overshoot to +13.0V for periods <20ns.
- WP#/ACC erase/program voltage is normally 2.7V-3.6V. Applying 11.7V-12.3V to WP#/ACC during erase/program can be done for a maximum of 1,000 cycles on each block. WP#/ACC may be connected to 11.7V-12.3V for a total of 80 hours maximum.
- Output shorted for no more than one second. No more than one output shorted at a time.

### 1.2 Operating Conditions

Parameter	Symbol	Min.	Typ.	Max.	Unit	Notes
Operating Temperature	T <sub>A</sub>	-40	+25	+85	°C	
V <sub>CC</sub> Supply Voltage	V <sub>CC</sub>	2.7	3.0	3.6	V	1
WP#/ACC Voltage when Used as a Logic Control	V <sub>IL</sub>	-0.2		0.4	V	1
	V <sub>IH</sub>	2.4		V <sub>CC</sub> +0.4	V	
WP#/ACC Supply Voltage	V <sub>ACCH</sub>	11.7	12.0	12.3	V	1, 2
Block Erase Cycling: WP#/ACC=V <sub>IL</sub> or V <sub>IH</sub>		100,000			Cycles	
Block Erase Cycling: WP#/ACC=V <sub>ACCH</sub> , 80 hrs.				1,000	Cycles	
Maximum WP#/ACC hours at V <sub>ACCH</sub>				80	Hours	

#### NOTES:

- See DC Characteristics tables for voltage range-specific specification.
- Applying WP#/ACC=11.7V-12.3V during a erase or program can be done for a maximum of 1,000 cycles on each block. A permanent connection to WP#/ACC=11.7V-12.3V is not allowed and can cause damage to the device.

### 1.2.1 Capacitance <sup>(1)</sup> ( $T_A=+25^{\circ}\text{C}$ , $f=1\text{MHz}$ )

Parameter	Symbol	Condition	Min.	Typ.	Max.	Unit
Input Capacitance	$C_{IN}$	$V_{IN}=0.0\text{V}$		4	7	pF
WP#/ACC Input Capacitance	$C_{IN}$	$V_{IN}=0.0\text{V}$		18	22	pF
Output Capacitance	$C_{OUT}$	$V_{OUT}=0.0\text{V}$		6	10	pF

NOTE:

1. Sampled, not 100% tested.

### 1.2.2 AC Input/Output Test Conditions

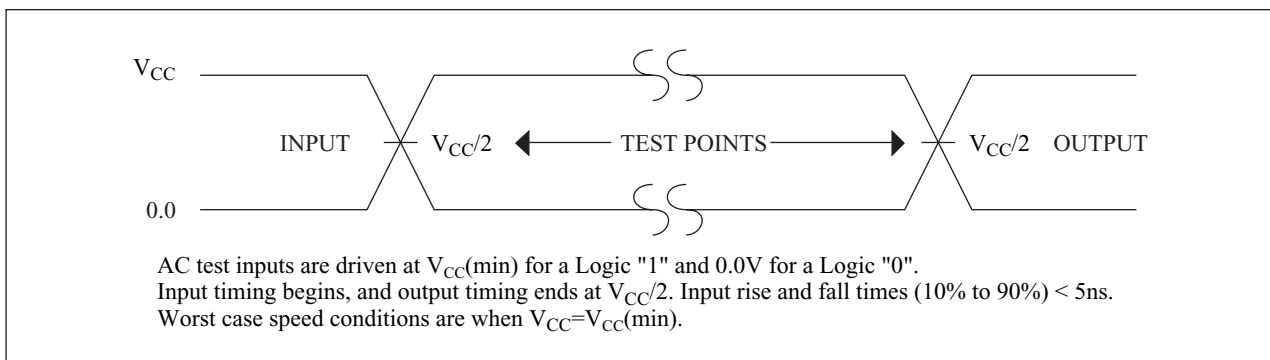

Figure 4. Transient Input/Output Reference Waveform for  $V_{CC}=2.7\text{V}-3.6\text{V}$

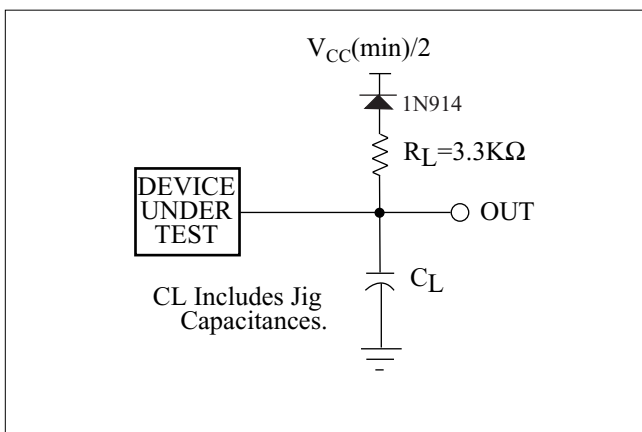

Figure 5. Transient Equivalent Testing Load Circuit

Table 9. Test Configuration Capacitance Loading Value

Test Configuration	$C_L$ (pF)
$V_{CC}=2.7\text{V}-3.6\text{V}$	50

## 1.2.3 DC Characteristics

$$V_{CC}=2.7V-3.6V$$

Symbol	Parameter	Notes	Min.	Typ.	Max.	Unit	Test Conditions
I <sub>LI</sub>	Input Load Current	1	-1.0		+1.0	μA	V <sub>CC</sub> =V <sub>CC</sub> Max., V <sub>IN</sub> /V <sub>OUT</sub> =V <sub>CC</sub> or GND
I <sub>LO</sub>	Output Leakage Current	1	-1.0		+1.0	μA	V <sub>CC</sub> =V <sub>CC</sub> Max., CE#=RST#= V <sub>CC</sub> ±0.2V, WP#/ACC=V <sub>CC</sub> or GND
I <sub>CCS</sub>	V <sub>CC</sub> Standby Current	1,6,7		4	10	μA	V <sub>CC</sub> =V <sub>CC</sub> Max., CE#=RST#= V <sub>CC</sub> ±0.2V, WP#/ACC=V <sub>CC</sub> or GND
I <sub>CCAS</sub>	V <sub>CC</sub> Automatic Power Savings Current	1,3,6		4	10	μA	V <sub>CC</sub> =V <sub>CC</sub> Max., CE#=GND±0.2V, WP#/ACC=V <sub>CC</sub> or GND
I <sub>CCD</sub>	V <sub>CC</sub> Reset Current	1,6		4	10	μA	RST#=GND±0.2V
I <sub>CCR</sub>	V <sub>CC</sub> Read Current	1,6			17	mA	V <sub>CC</sub> =V <sub>CC</sub> Max., CE#=V <sub>IL</sub> , OE#=V <sub>IH</sub> , f=5MHz
I <sub>CCW</sub>	V <sub>CC</sub> Program Current	1,4,6		20	60	mA	WP#/ACC=V <sub>IL</sub> or V <sub>IH</sub>
		1,4,6		10	20	mA	WP#/ACC=V <sub>ACCH</sub>
I <sub>CCE</sub>	V <sub>CC</sub> Block Erase, Full Chip Erase Current	1,4,6		10	30	mA	WP#/ACC=V <sub>IL</sub> or V <sub>IH</sub>
		1,4,6		4	10	mA	WP#/ACC=V <sub>ACCH</sub>
I <sub>CCWS</sub> I <sub>CCES</sub>	V <sub>CC</sub> Program or Block Erase Suspend Current	1,2,6		10	200	μA	CE#=V <sub>IH</sub>
I <sub>ACCS</sub> I <sub>ACCR</sub>	WP#/ACC Standby or Read Current	1,5,6		2	5	μA	WP#/ACC≤V <sub>CC</sub>
I <sub>ACCW</sub>	WP#/ACC Program Current	1,4,5,6		2	5	μA	WP#/ACC=V <sub>IL</sub> or V <sub>IH</sub>
		1,4,5,6		10	30	mA	WP#/ACC=V <sub>ACCH</sub>
I <sub>ACCE</sub>	WP#/ACC Block Erase, Full Chip Erase Current	1,4,5,6		2	5	μA	WP#/ACC=V <sub>IL</sub> or V <sub>IH</sub>
		1,4,5,6		5	15	mA	WP#/ACC=V <sub>ACCH</sub>
I <sub>ACCWS</sub>	WP#/ACC Program Suspend Current	1,5,6		2	5	μA	WP#/ACC=V <sub>IL</sub> or V <sub>IH</sub>
		1,5,6		10	200	μA	WP#/ACC=V <sub>ACCH</sub>
I <sub>ACCES</sub>	WP#/ACC Block Erase Suspend Current	1,5,6		2	5	μA	WP#/ACC=V <sub>IL</sub> or V <sub>IH</sub>
		1,5,6		10	200	μA	WP#/ACC=V <sub>ACCH</sub>

## DC Characteristics (Continued)

$$V_{CC}=2.7V-3.6V$$

Symbol	Parameter	Notes	Min.	Typ.	Max.	Unit	Test Conditions
V <sub>IL</sub>	Input Low Voltage	5	-0.4		0.4	V	
V <sub>IH</sub>	Input High Voltage	4	2.4		V <sub>CC</sub> + 0.4	V	
V <sub>OL</sub>	Output Low Voltage	4,7			0.2	V	V <sub>CC</sub> =V <sub>CC</sub> Min., I <sub>OL</sub> =100μA
V <sub>OH</sub>	Output High Voltage	4	V <sub>CC</sub> -0.2			V	V <sub>CC</sub> =V <sub>CC</sub> Min., I <sub>OH</sub> =-100μA
V <sub>ACCH</sub>	WP#/ACC during Block Erase, Full Chip Erase, Program or OTP Program Operations	5	11.7	12.0	12.3	V	
V <sub>LKO</sub>	V <sub>CC</sub> Lockout Voltage		1.5			V	

## NOTES:

- All currents are in RMS unless otherwise noted. Typical values are the reference values at V<sub>CC</sub>=3.0V and T<sub>A</sub>=+25°C unless V<sub>CC</sub> is specified.
- I<sub>CCWS</sub> and I<sub>CCES</sub> are specified with the device de-selected. If read or program is executed while in block erase suspend mode, the device's current draw is the sum of I<sub>CCES</sub> and I<sub>CCR</sub> or I<sub>CCW</sub>. If read is executed while in program suspend mode, the device's current draw is the sum of I<sub>CCWS</sub> and I<sub>CCR</sub>.
- The Automatic Power Savings (APS) feature automatically places the device in power save mode after read cycle completion. Standard address access timings (t<sub>AVQV</sub>) provide new data when addresses are changed.
- Sampled, not 100% tested.
- Applying 12.0V±0.3V to WP#/ACC provides fast erasing or fast programming mode. In this mode, WP#/ACC is power supply pin and supplies the memory cell current for block erasing and programming. Use similar power supply trace widths and layout considerations given to the V<sub>CC</sub> power bus.  
Applying 12.0V±0.3V to WP#/ACC during erase/program can only be done for a maximum of 1,000 cycles on each block. WP#/ACC may be connected to 12.0V±0.3V for a total of 80 hours maximum.
- For all pins other than those shown in test conditions, input level is V<sub>CC</sub> or GND.
- Includes RY/BY#.

1.2.4 AC Characteristics - Read-Only Operations<sup>(1)</sup>
 $V_{CC}=2.7V-3.6V, T_A=-40^{\circ}C \text{ to } +85^{\circ}C$ 

Symbol	Parameter	Notes	Min.	Max.	Unit
$t_{AVAV}$	Read Cycle Time		90		ns
$t_{AVQV}$	Address to Output Delay			90	ns
$t_{ELQV}$	CE# to Output Delay	3		90	ns
$t_{GLQV}$	OE# to Output Delay	3		20	ns
$t_{PHQV}$	RST# High to Output Delay			150	ns
$t_{EHQZ}, t_{GHQZ}$	CE# or OE# to Output in High Z, Whichever Occurs First	2		20	ns
$t_{ELQX}$	CE# to Output in Low Z	2	0		ns
$t_{GLQX}$	OE# to Output in Low Z	2	0		ns
$t_{OH}$	Output Hold from First Occurring Address, CE# or OE# change	2	0		ns

## NOTES:

1. See AC input/output reference waveform for timing measurements and maximum allowable input slew rate.
2. Sampled, not 100% tested.
3. OE# may be delayed up to  $t_{ELQV} - t_{GLQV}$  after the falling edge of CE# without impact to  $t_{ELQV}$ .

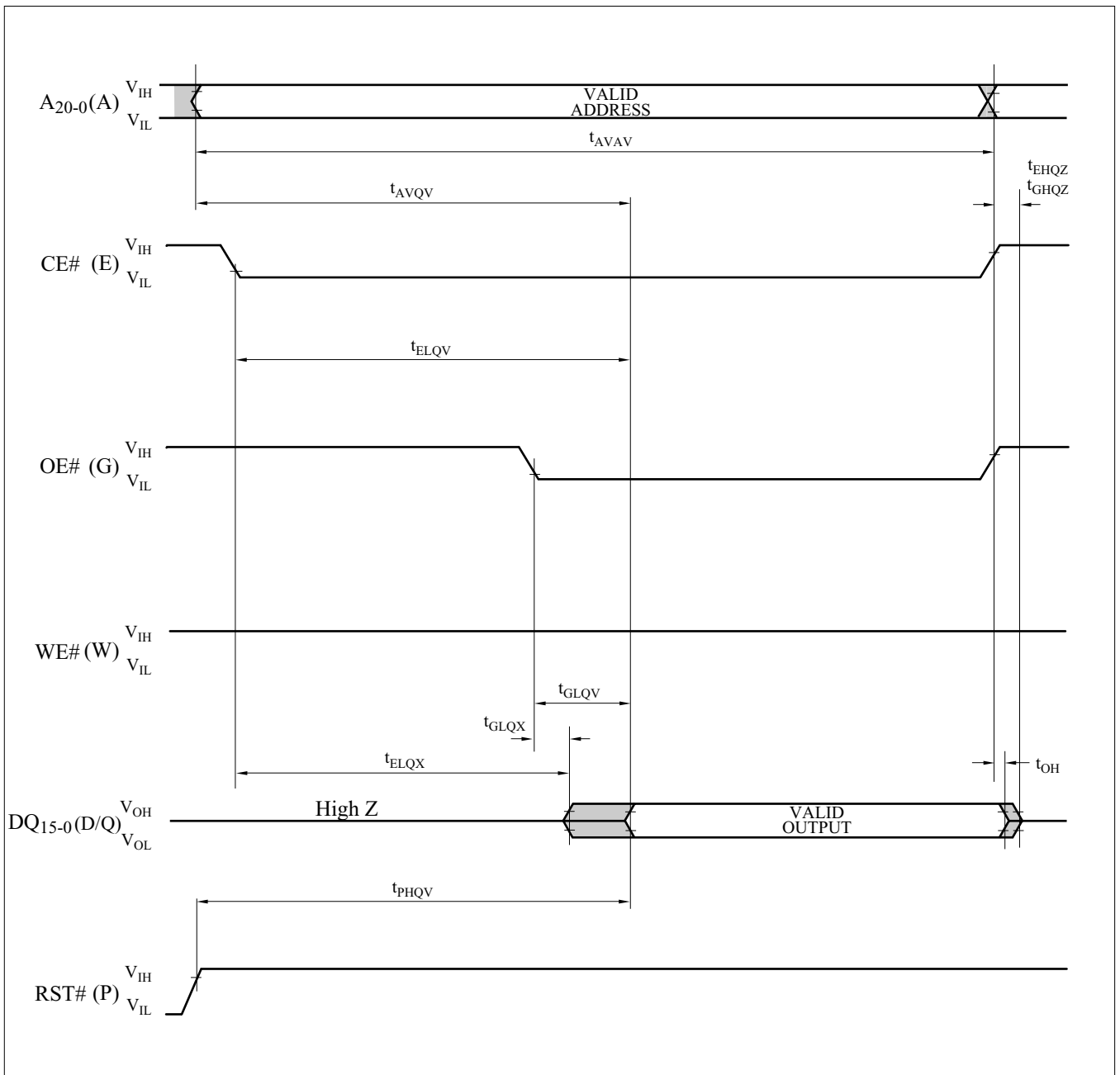

Figure 6. AC Waveform for Read Operations

1.2.5 AC Characteristics - Write Operations<sup>(1), (2)</sup>

$$V_{CC}=2.7V-3.6V, T_A=-40^{\circ}C \text{ to } +85^{\circ}C$$

Symbol	Parameter	Notes	Min.	Max.	Unit
$t_{AVAV}$	Write Cycle Time		90		ns
$t_{PHWL}$ ( $t_{PHEL}$ )	RST# High Recovery to WE# (CE#) Going Low	3	150		ns
$t_{ELWL}$ ( $t_{WLEL}$ )	CE# (WE#) Setup to WE# (CE#) Going Low		0		ns
$t_{WLWH}$ ( $t_{ELEH}$ )	WE# (CE#) Pulse Width	4	60		ns
$t_{DVWH}$ ( $t_{DVEH}$ )	Data Setup to WE# (CE#) Going High	7	40		ns
$t_{AVWH}$ ( $t_{AVEH}$ )	Address Setup to WE# (CE#) Going High	7	50		ns
$t_{WHEH}$ ( $t_{EHWH}$ )	CE# (WE#) Hold from WE# (CE#) High		0		ns
$t_{WHDX}$ ( $t_{EHDX}$ )	Data Hold from WE# (CE#) High		0		ns
$t_{WHAX}$ ( $t_{EHAX}$ )	Address Hold from WE# (CE#) High		0		ns
$t_{WHWL}$ ( $t_{EHEL}$ )	WE# (CE#) Pulse Width High	5	30		ns
$t_{SHWH}$ ( $t_{SHEH}$ )	WP#/ACC High Setup to WE# (CE#) Going High	WP#/ACC= $V_{IH}$	0		ns
		WP#/ACC= $V_{ACCH}$	200		
$t_{WHGL}$ ( $t_{EHGL}$ )	Write Recovery before Read		30		ns
$t_{QVSL}$	WP#/ACC High Hold from Valid SRD, RY/BY# High Z	3	0		ns
$t_{WHR0}$ ( $t_{EHR0}$ )	WE# (CE#) High to SR.7 Going "0"	3, 6		$t_{AVQV} + 50$	ns
$t_{WHRL}$ ( $t_{EHRL}$ )	WE# (CE#) High to RY/BY# Going Low	3		100	ns

## NOTES:

- The timing characteristics for reading the status register during block erase, full chip erase, program and OTP program operations are the same as during read-only operations. Refer to AC Characteristics for read-only operations.
- A write operation can be initiated and terminated with either CE# or WE#.
- Sampled, not 100% tested.
- Write pulse width ( $t_{WP}$ ) is defined from the falling edge of CE# or WE# (whichever goes low last) to the rising edge of CE# or WE# (whichever goes high first). Hence,  $t_{WP}=t_{WLWH}=t_{ELEH}=t_{WLEH}=t_{ELWH}$ .
- Write pulse width high ( $t_{WPH}$ ) is defined from the rising edge of CE# or WE# (whichever goes high first) to the falling edge of CE# or WE# (whichever goes low last). Hence,  $t_{WPH}=t_{WHWL}=t_{EHEL}=t_{WHEL}=t_{EHWL}$ .
- $t_{WHR0}$  ( $t_{EHR0}$ ) after the Read Query or Read Identifier Codes/OTP command= $t_{AVQV}+100ns$ .
- Refer to Table 4 for valid address and data for block erase, full chip erase, program, OTP program or lock bit configuration.

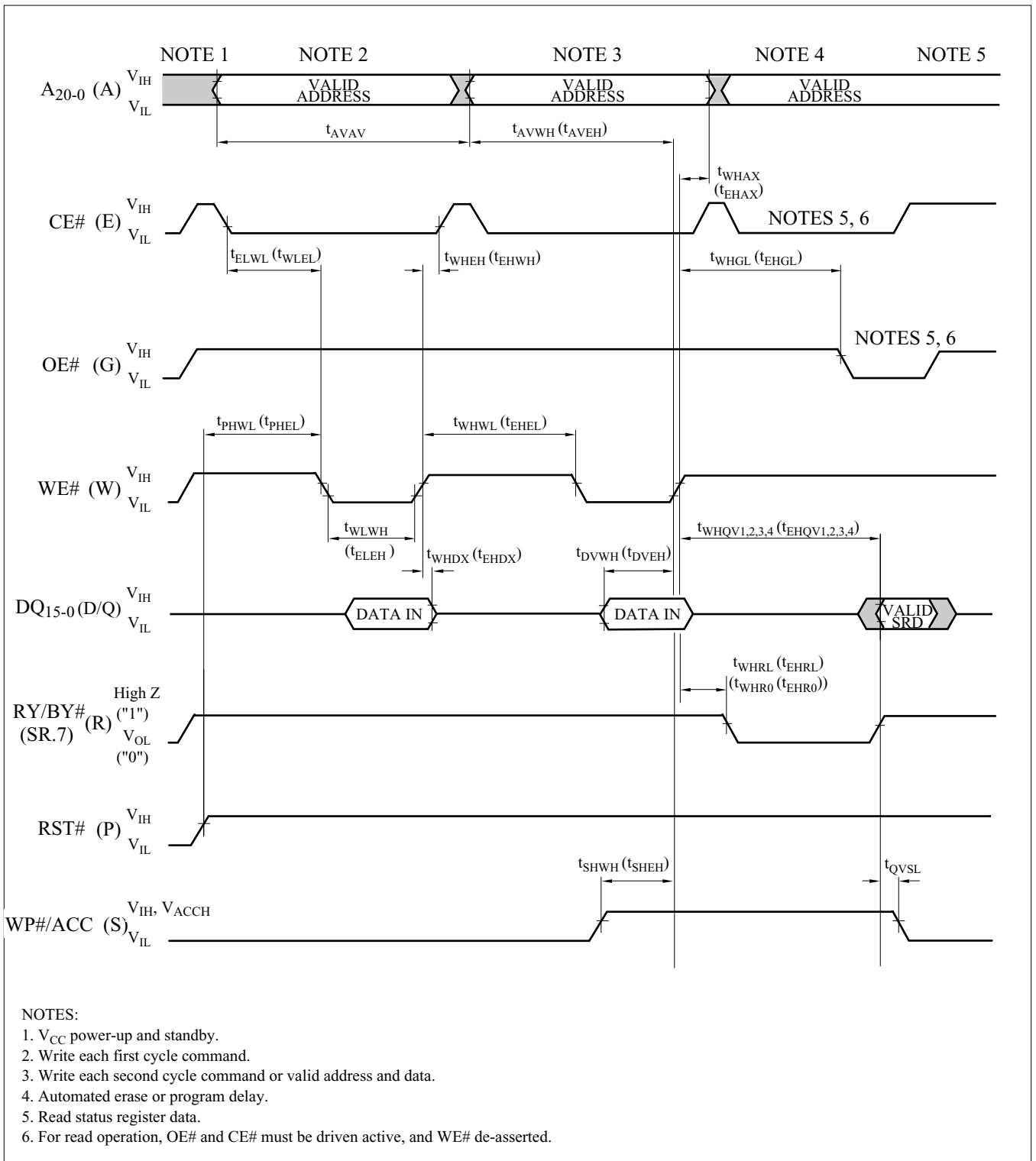

Figure 7. AC Waveform for Write Operations

## 1.2.6 Reset Operations

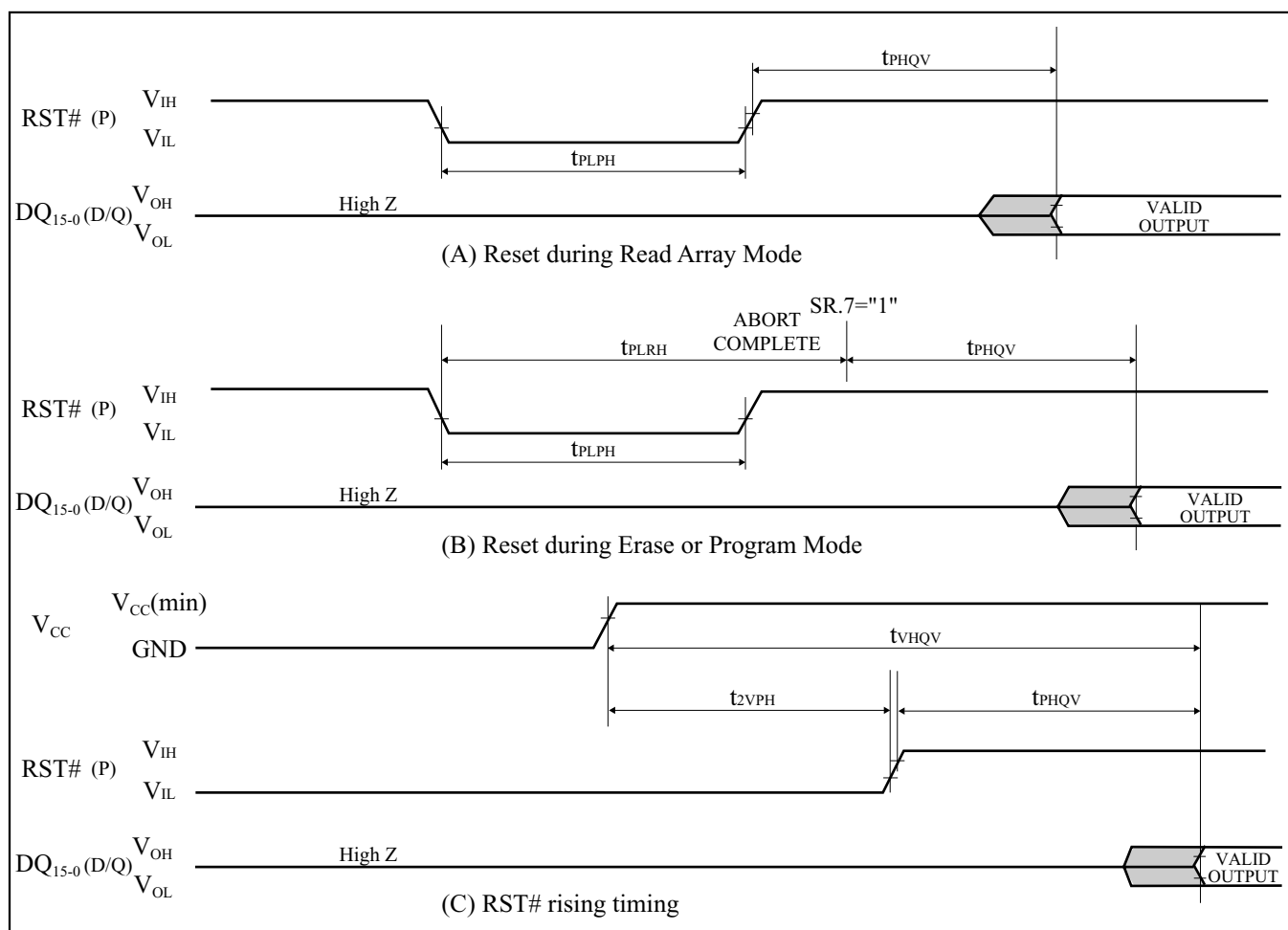

Figure 8. AC Waveform for Reset Operations

Reset AC Specifications ( $V_{CC}=2.7V-3.6V$ ,  $T_A=-40^{\circ}C$  to  $+85^{\circ}C$ )

Symbol	Parameter	Notes	Min.	Max.	Unit
$t_{PLPH}$	RST# Low to Reset during Read (RST# should be low during power-up.)	1, 2, 3	100		ns
$t_{PLRH}$	RST# Low to Reset during Erase or Program	1, 3, 4		22	$\mu s$
$t_{2VPH}$	$V_{CC}$ 2.7V to RST# High	1, 3, 5	100		ns
$t_{VHQP}$	$V_{CC}$ 2.7V to Output Delay	3		1	ms

**NOTES:**

1. A reset time,  $t_{PHQV}$ , is required from the later of SR.7 (RY/BY#) going "1" (High Z) or RST# going high until outputs are valid. Refer to AC Characteristics - Read-Only Operations for  $t_{PHQV}$ .
2.  $t_{PLPH}$  is  $<100ns$  the device may still reset but this is not guaranteed.
3. Sampled, not 100% tested.
4. If RST# asserted while a block erase, full chip erase, program or OTP program operation is not executing, the reset will complete within 100ns.
5. When the device power-up, holding RST# low minimum 100ns is required after  $V_{CC}$  has been in predefined range and also has been in stable there.

1.2.7 Block Erase, Full Chip Erase, Program and OTP Program Performance<sup>(3)</sup> $V_{CC}=2.7V-3.6V$ ,  $T_A=-40^{\circ}C$  to  $+85^{\circ}C$ 

Symbol	Parameter	Notes	WP#/ACC= $V_{IL}$ or $V_{IH}$ (In System)			WP#/ACC= $V_{ACCH}$ (In Manufacturing)			Unit
			Min.	Typ. <sup>(1)</sup>	Max. <sup>(2)</sup>	Min.	Typ. <sup>(1)</sup>	Max. <sup>(2)</sup>	
$t_{WPB}$	4-Kword Parameter Block Program Time	2		0.05	0.3		0.04	0.12	s
$t_{WMB1}$	32-Kword Block Program Time	2		0.34	2.4		0.31	1.0	s
$t_{WMB2}$	64-Kword Block Program Time	2		0.68	4.8		0.62	2.0	s
$t_{WHQV1}/$ $t_{EHQV1}$	Word Program Time	2		10	200		9	185	$\mu s$
$t_{WHOV1}/$ $t_{EHOV1}$	OTP Program Time	2		36	400		27	185	$\mu s$
$t_{WHQV2}/$ $t_{EHQV2}$	4-Kword Parameter Block Erase Time	2		0.26	4		0.2	4	s
$t_{WHQV3}/$ $t_{EHQV3}$	32-Kword Block Erase Time	2		0.51	5		0.5	5	s
$t_{WHQV4}/$ $t_{EHQV4}$	64-Kword Block Erase Time	2		0.82	8		0.8	8	s
	Full Chip Erase Time	2		40	350		33	350	s
$t_{WHRH1}/$ $t_{EHRH1}$	Program Suspend Latency Time to Read	4		5	10		5	10	$\mu s$
$t_{WHRH2}/$ $t_{EHRH2}$	Block Erase Suspend Latency Time to Read	4		5	20		5	20	$\mu s$
$t_{ERES}$	Latency Time from Block Erase Resume Command to Block Erase Suspend Command	5	500			500			$\mu s$

## NOTES:

1. Typical values measured at  $V_{CC}=3.0V$ , WP#/ACC=3.0V or 12.0V, and  $T_A=+25^{\circ}C$ . Assumes corresponding lock bits are not set. Subject to change based on device characterization.
2. Excludes external system-level overhead.
3. Sampled, but not 100% tested.
4. A latency time is required from writing suspend command (WE# or CE# going high) until SR.7 going "1" or RY/BY# going High Z.
5. If the interval time from a Block Erase Resume command to a subsequent Block Erase Suspend command is shorter than  $t_{ERES}$  and its sequence is repeated, the block erase operation may not be finished.

## 2 Related Document Information<sup>(1)</sup>

Document No.	Document Name
FUM03802	LHF00LXX series Appendix

NOTE:

1. International customers should contact their local SHARP or distribution sales offices.

### 3 Package and packing specification

[Applicability]

This specification applies to IC package of the LEAD-FREE delivered as a standard specification.

#### 1.Storage Conditions.

##### 1-1.Storage conditions required before opening the dry packing.

- Normal temperature : 5~40°C
- Normal humidity : 80%( Relative humidity) max.
- "Humidity" means "Relative humidity"

##### 1-2.Storage conditions required after opening the dry packing.

In order to prevent moisture absorption after opening, ensure the following storage conditions apply:

- (1) Storage conditions for one-time soldering. (Convection reflow<sup>\*1</sup>, IR/Convection reflow.<sup>\*1</sup>, or Manual soldering. )
  - Temperature : 5~25°C
  - Humidity : 60% max.
  - Period : 72 hours max. after opening.
- (2) Storage conditions for two-time soldering. (Convection reflow<sup>\*1</sup>, IR/Convection reflow.<sup>\*1</sup>)
  - a. Storage conditions following opening and prior to performing the 1st reflow.
    - Temperature : 5~25°C
    - Humidity : 60% max.
    - Period : 72 hours max. after opening.
  - b. Storage conditions following completion of the 1st reflow and prior to performing the 2nd reflow.
    - Temperature : 5~25°C
    - Humidity : 60% max.
    - Period : 72 hours max. after completion of the 1st reflow.

<sup>\*1</sup>:Air or nitrogen environment.

##### 1-3.Temporary storage after opening.

To re-store the devices before soldering, do so only once and use a dry box or place desiccant (with a blue humidity indicator) with the devices and perform dry packing again using heat-sealing.

The storage period, temperature and humidity must be as follows :

##### (1) Storage temperature and humidity.

※1 : External atmosphere temperature and humidity of the dry packing.

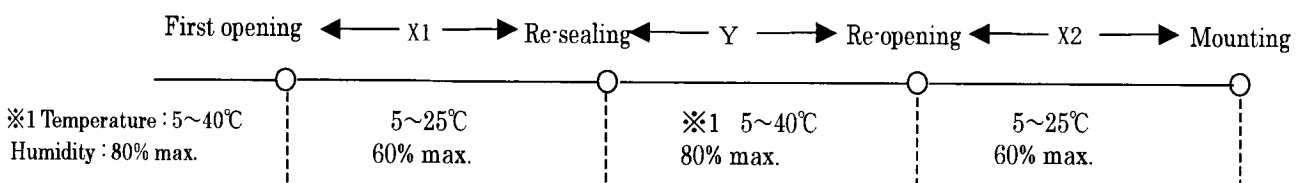

##### (2) Storage period.

- X1 + X2 : Refer to Section 1-2(1) and (2)a , depending on the mounting method.
- Y : Two weeks max.

## 2. Baking Condition.

### (1) Situations requiring baking before mounting.

- Storage conditions exceed the limits specified in Section 1-2 or 1-3.
- Humidity indicator in the desiccant was already red (pink) when opened.  
( Also for re-opening.)

### (2) Recommended baking conditions.

- Baking temperature and period :  
120°C for 16~24 hours.
- The above baking conditions apply since the trays are heat-resistant.

### (3) Storage after baking.

- After baking, store the devices in the environment specified in Section 1-2 and mount immediately.

## 3. Surface mount conditions.

The following soldering condition are recommended to ensure device quality.

### 3-1.Soldering.

#### (1) Convection reflow or IR/Convection. (one-time soldering or two-time soldering in air or nitrogen environment)

- Temperature and period :
 

A) Peak temperature.	250°C max.
B) Heating temperature.	40 to 60 seconds as 220°C
C) Preheat temperature.	It is 150 to 200°C, and is 120±30 seconds
D) Temperature increase rate.	It is 1 to 3°C/seconds
- Measuring point : IC package surface.
- Temperature profile:

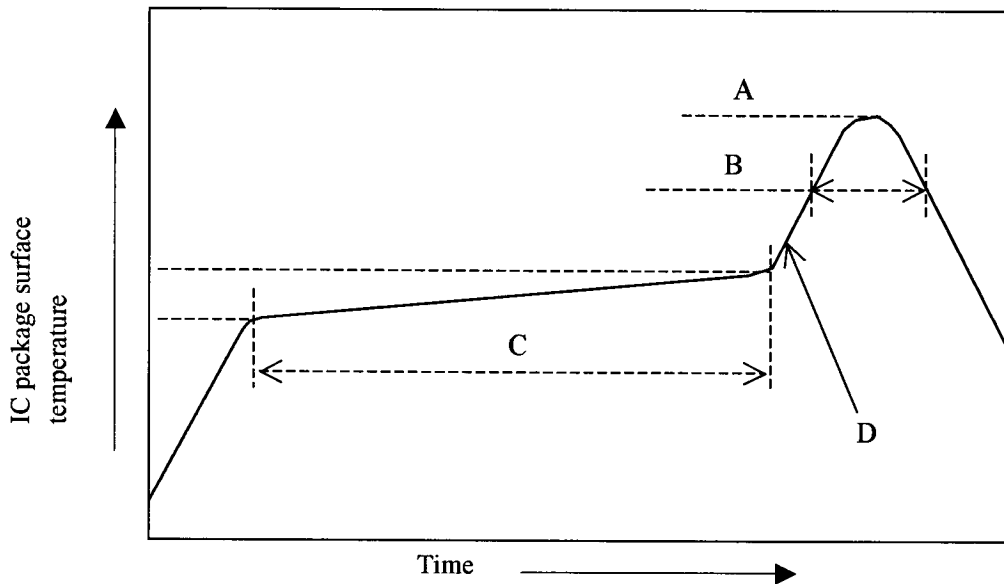

- (2) Manual soldering ( soldering iron ) ( one-time soldering only )  
Soldering iron should only touch the IC's outer leads.

- Temperature and period :  
350°C max. for 3 seconds / pin max.  
(Soldering iron should only touch the IC's outer leads.)
- Measuring point : Soldering iron tip.

4. Condition for removal of residual flux.

- (1) Ultrasonic washing power : 25 watts / liter max.
- (2) Washing time : Total 1 minute max.
- (3) Solvent temperature : 15~40°C

5. Package outline specification.

Refer to the attached drawing.

(Plastic body dimensions do not include burr of resin.)

The contents of LEAD-FREE TYPE application of the specifications. (\*2)

6. Markings.

6-1. Marking details. (The information on the package should be given as follows.)

- (1) Product name : LHF00L15
- (2) Company name : SHARP
- (3) Date code

(Example) YY WW XXX

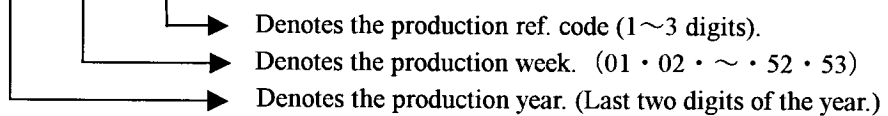

- (4) "JAPAN" indicates the country of origin.

6-2. Marking layout.

The layout is shown in the attached drawing.

(However, this layout does not specify the size of the marking character and marking position.)

\*2 The contents of LEAD-FREE TYPE application of the specifications.

LEAD FINISH or BALL TYPE	LEAD-FREE TYPE (Sn-Bi)
DATE CODE	They are those with an underline under YYWW XXX
The word of " LEAD FREE" is printed on the packing label	Printed

(Note) It is those with an underline printing in a date code because of a LEAD-FREE type.

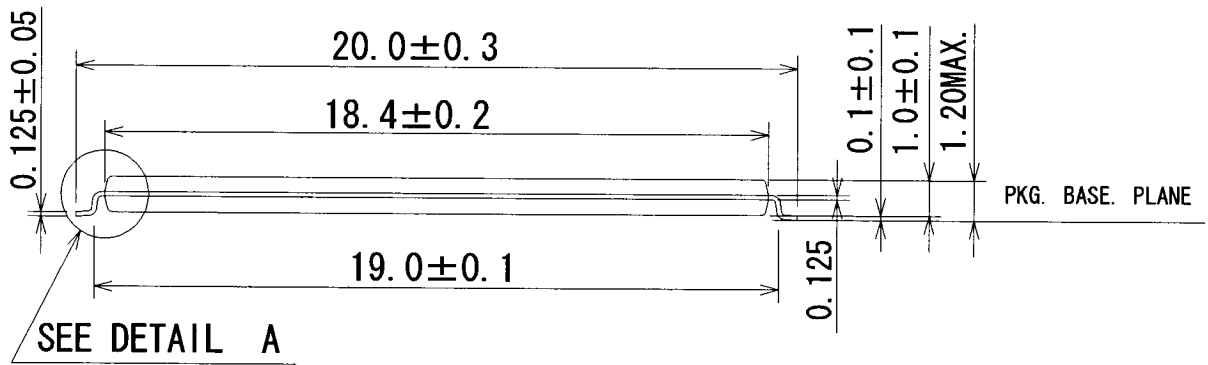
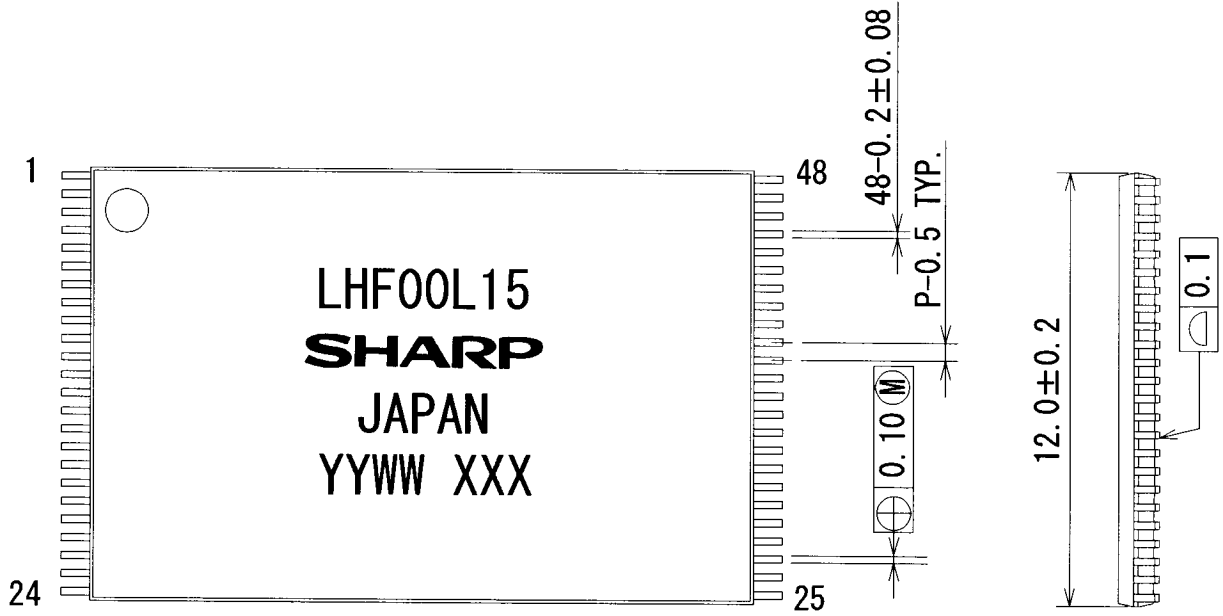

DETAIL A

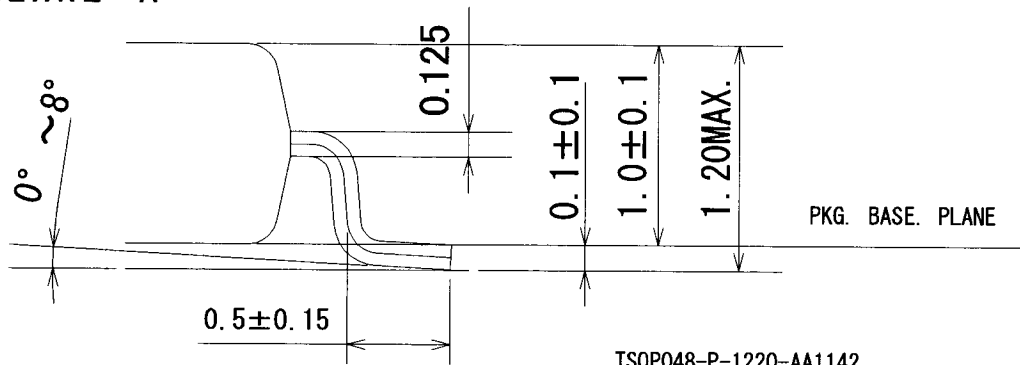

TSOP048-P-1220-AA1142

LEAD TYPE	LEAD FINISH		LEAD MATERIAL	
	Sn-Bi PLATING		42Alloy	
NAME	TSOP048-P-1220			NOTE : Plastic body dimensions do not include burr of resin.
DRAWING NO.	AA1142	UNIT	mm	

7. Packing Specifications (Dry packing for surface mount packages.)

7-1. Packing materials.

Material name	Material specifications	Purpose
Inner carton	Cardboard (960 devices / inner carton max.)	Packing the devices. (10 trays / inner carton)
Tray	Conductive plastic (96 devices / tray)	Securing the devices.
Upper cover tray	Conductive plastic (1 tray / inner carton)	Securing the devices.
Laminated aluminum bag	Aluminum polyethylene	Keeping the devices dry.
Desiccant	Silica gel	Keeping the devices dry.
Label	Paper	Indicates part number, quantity, and packed date.
PP band	Polypropylene (3 pcs. / inner carton )	Securing the devices.
Outer carton	Cardboard (3840 devices / outer carton max.)	Outer packing.

( Devices must be placed on the tray in the same direction.)

7-2. Outline dimension of tray.

Refer to the attached drawing.

7-3. Outline dimension of carton.

Refer to the attached drawing.

8. Precautions for use.

- (1) Opening must be done on an anti-ESD treated workbench.  
All workers must also have undergone anti-ESD treatment.
- (2) The trays have undergone either conductive or anti-ESD treatment.  
If another tray is used, make sure it has also undergone conductive or anti-ESD treatment.
- (3) The devices should be mounted the devices within one year of the date of delivery.

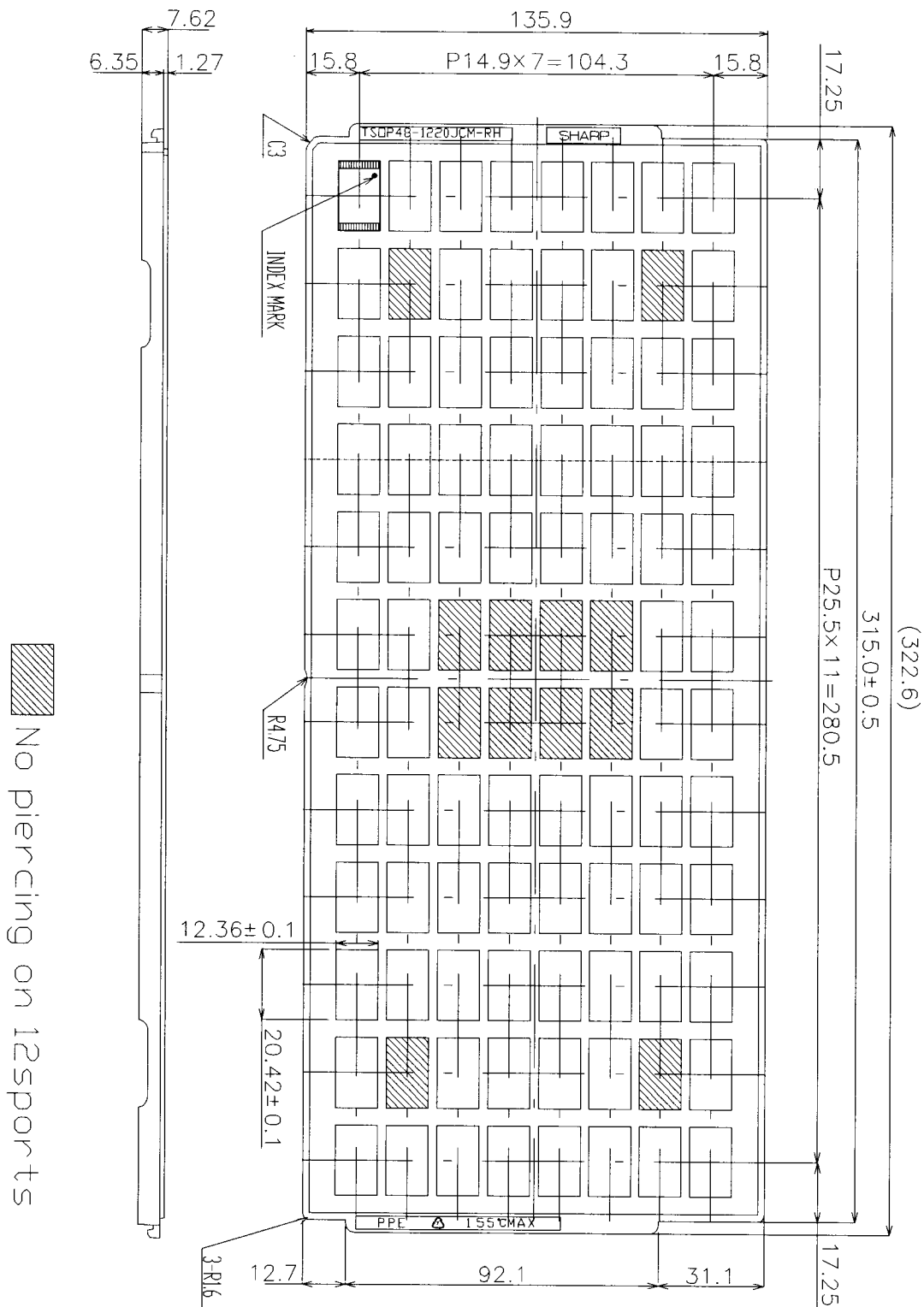

 No piercing on 12spports

名称 NAME	TSOP48-1220JCM-RH-N		備考 NOTE
DRAWING NO.	CV911	単位 UNIT	mm

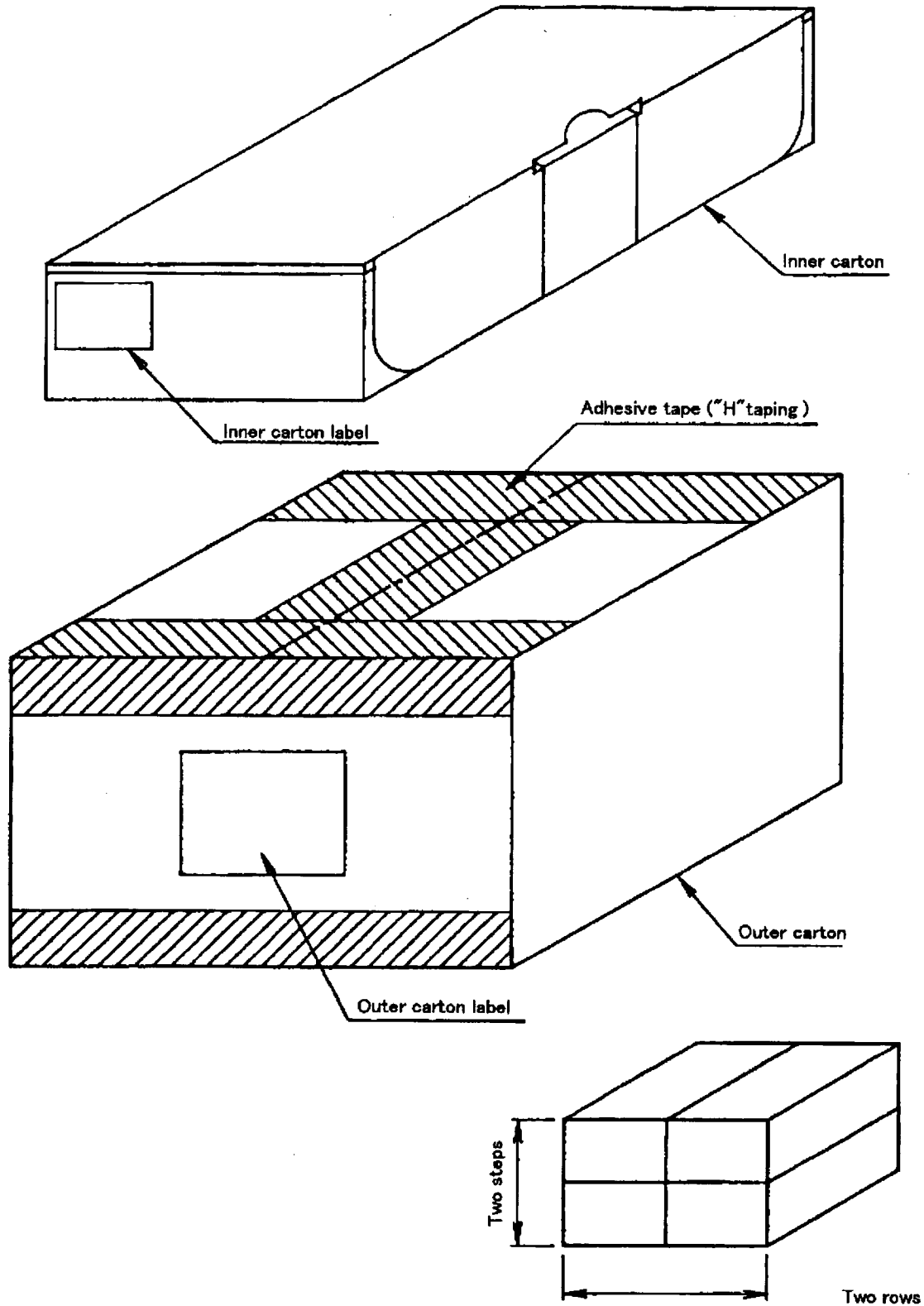

L × W × H

Inner carton - Outer dimensions : 335×150×80

Outer carton - Outer dimensions : 340×310×175

名称 NAME	トレイ品 包装仕様 Packing specifications		備考 NOTE
DRAWING NO.	BJ433	単位 UNIT	
		mm	出荷数量が端数の場合、本仕様と異なることがあります。 There is a possibility different from this specification when the number of shipments is fractions.

(Note) The <LEAD-FREE> display shows a lead-free article.

## Inner carton label

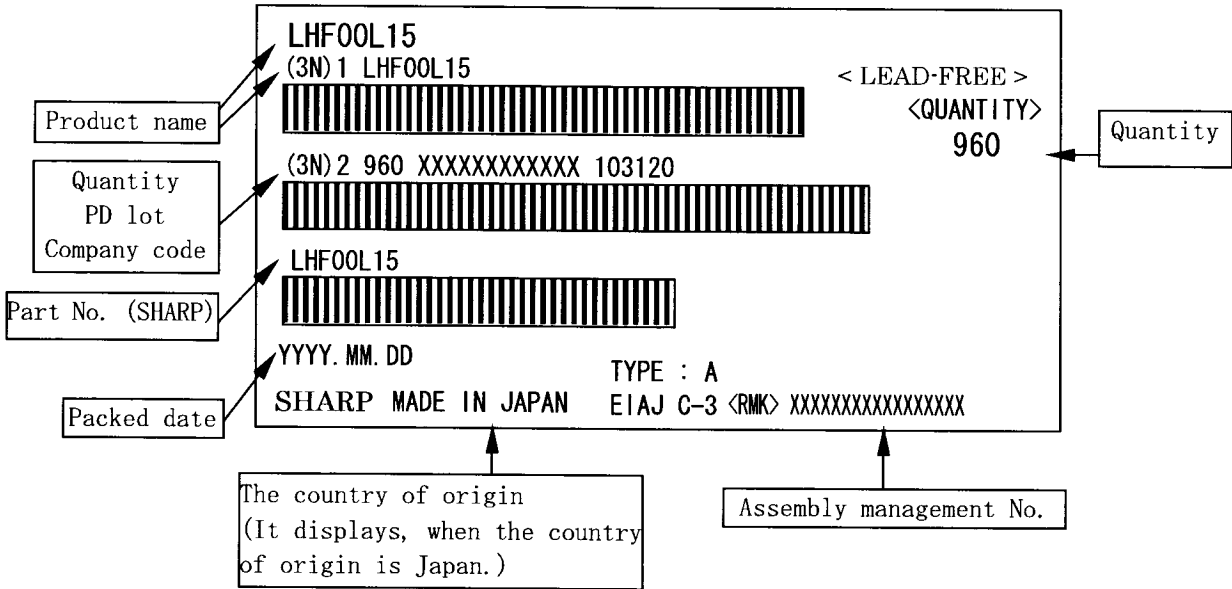

## Outer carton label

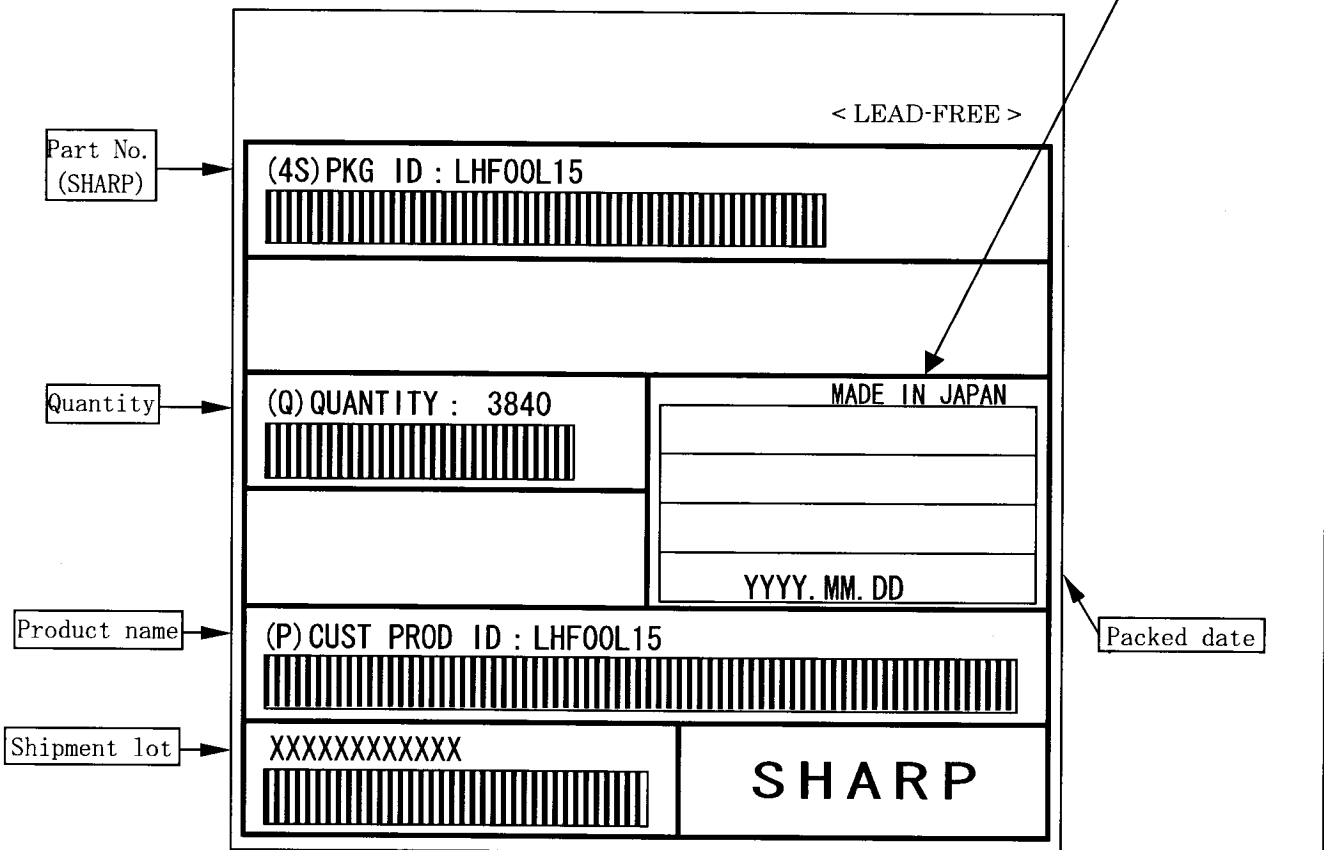

(Former) EIAJ B Standard conforming

## A-1 RECOMMENDED OPERATING CONDITIONS

### A-1.1 At Device Power-Up

AC timing illustrated in Figure A-1 is recommended for the supply voltages and the control signals at device power-up. If the timing in the figure is ignored, the device may not operate correctly.

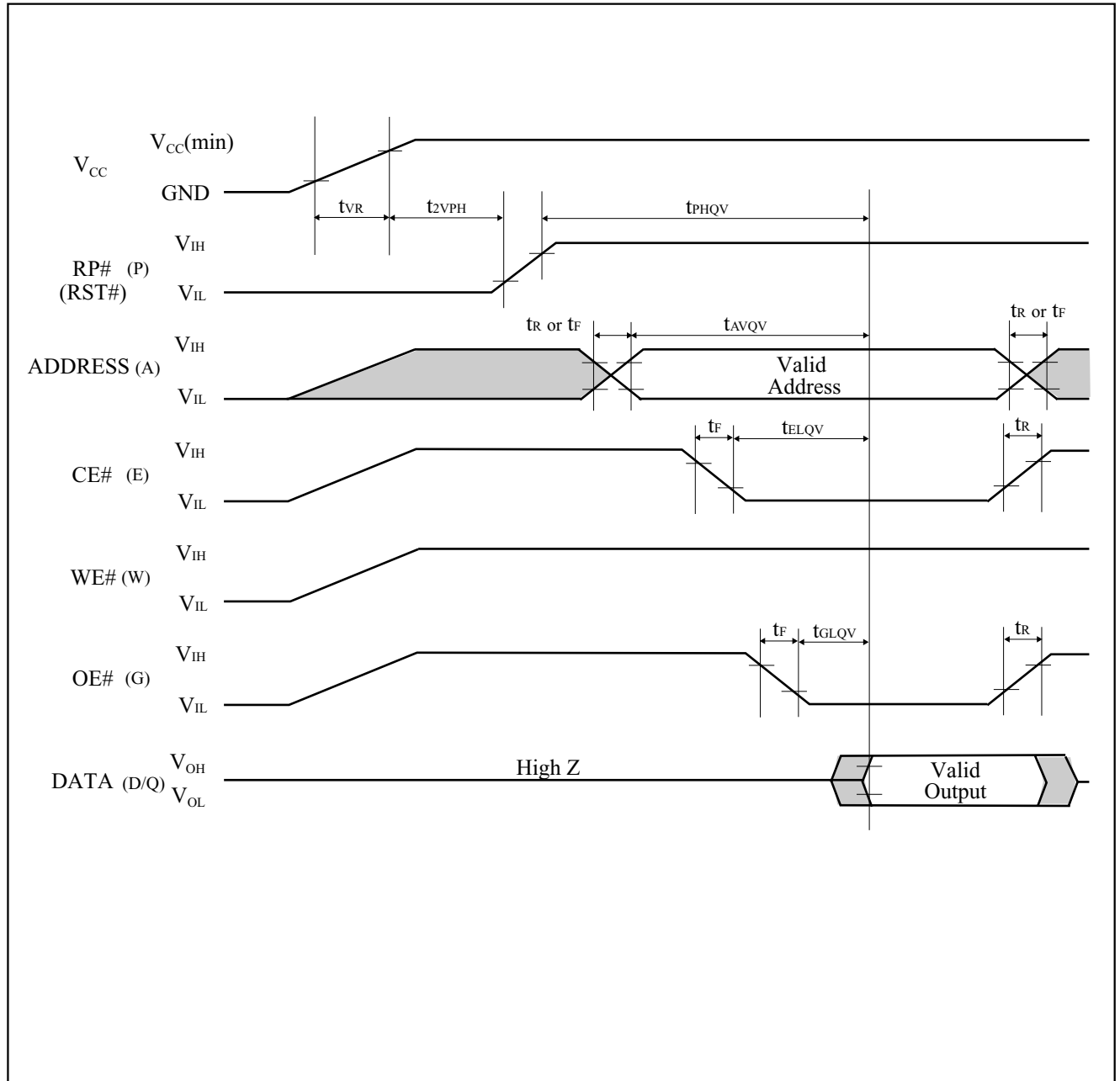

Figure A-1. AC Timing at Device Power-Up

For the AC specifications  $t_{VR}$ ,  $t_r$ ,  $t_f$  in the figure, refer to the next page. See the “ELECTRICAL SPECIFICATIONS” described in specifications for the supply voltage range, the operating temperature and the AC specifications not shown in the next page.

## A-1.1.1 Rise and Fall Time

Symbol	Parameter	Notes	Min.	Max.	Unit
$t_{VR}$	$V_{CC}$ Rise Time	1	0.5	30000	$\mu\text{s}/\text{V}$
$t_R$	Input Signal Rise Time	1, 2		1	$\mu\text{s}/\text{V}$
$t_F$	Input Signal Fall Time	1, 2		1	$\mu\text{s}/\text{V}$

### NOTES:

1. Sampled, not 100% tested.
2. This specification is applied for not only the device power-up but also the normal operations.

## A-1.2 Glitch Noises

Do not input the glitch noises which are below  $V_{IH}$  (Min.) or above  $V_{IL}$  (Max.) on address, data, reset, and control signals, as shown in Figure A-2 (b). The acceptable glitch noises are illustrated in Figure A-2 (a).

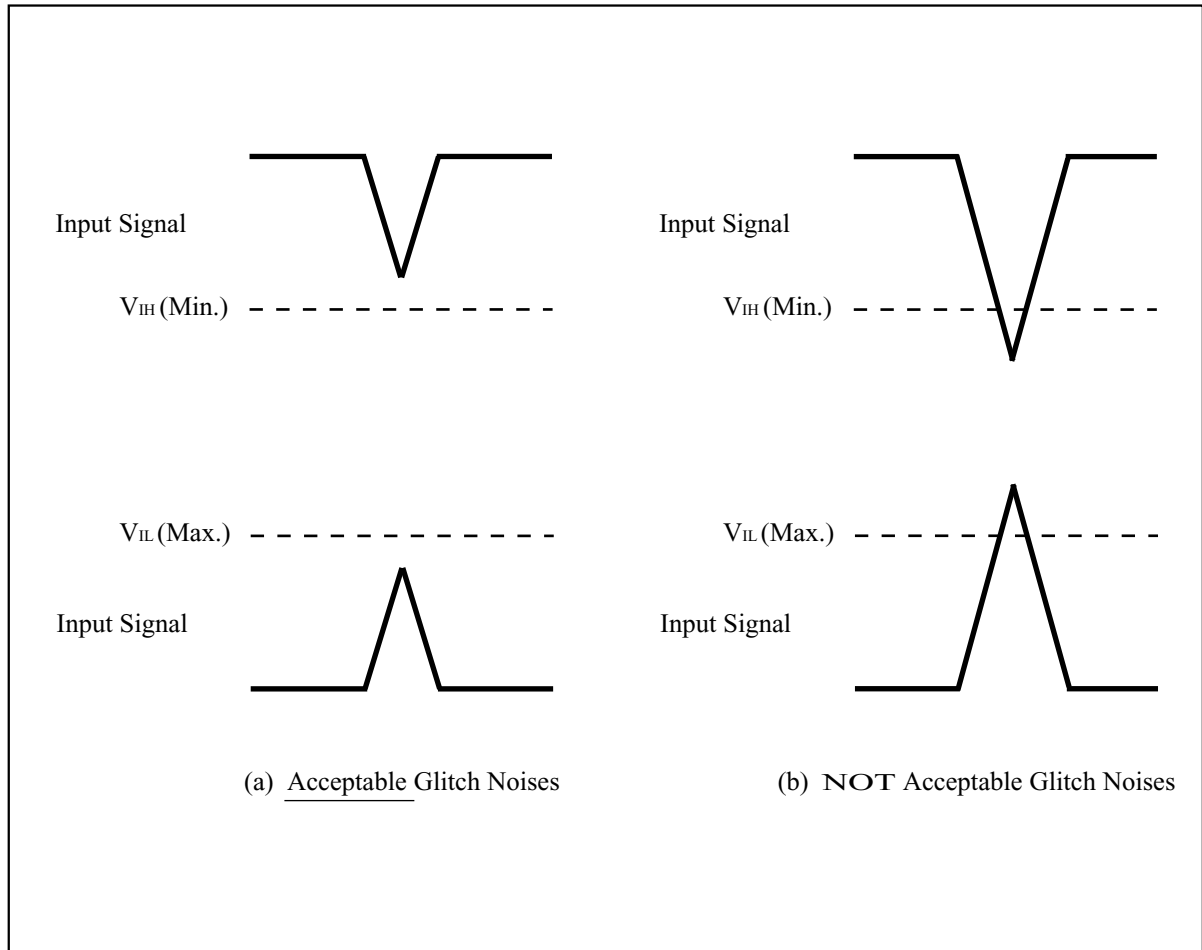

Figure A-2. Waveform for Glitch Noises

See the “DC CHARACTERISTICS” described in specifications for  $V_{IH}$  (Min.) and  $V_{IL}$  (Max.).

## A-2 RELATED DOCUMENT INFORMATION<sup>(1)</sup>

Document No.	Document Name
AP-001-SD-E	Flash Memory Family Software Drivers
AP-006-PT-E	Data Protection Method of SHARP Flash Memory
AP-007-SW-E	RP#, $V_{PP}$ Electric Potential Switching Circuit



NOTE:

1. International customers should contact their local SHARP or distribution sales office.



## Looking for pricing, stock, or lifecycle information?

Click below to explore more details on WIN SOURCE:

-  [View LHF00L15 on WIN SOURCE](#)
-  [Sharp Microelectronics Information](#)

## Optimize Your Supply Chain with WIN SOURCE Solutions

-  Global Sourcing Solution
-  Obsolete Management
-  Cost Control Management
-  Shortage Management
-  Alternative Solution
-  Excess Inventory Management