



**THE DATASHEET OF  
LDC1101DRCT**



# LDC1101 1.8-V High-Resolution, High-Speed Inductance-to-Digital Converter

## 1 Features

- Wide Operating Voltage Range: 1.8 V to 3.3 V
- Sensor Frequency Range: 500 kHz to 10 MHz
- $R_p$  Resolution: 16-Bit
- L Resolution: 16- or 24-Bit
- 180-kSPS Conversion Rate
- Threshold Detection Functionality
- 1% Part-to-Part Variation in  $R_p$  Measurement
- Supply Current:
  - 1.4- $\mu$ A Shutdown mode
  - 135- $\mu$ A Sleep mode
  - 1.9-mA Active Mode (no sensor connected)
- Sub-Micron Distance Resolution Achievable
- Remote Sensor Placement Isolating the LDC from Harsh Environments
- Robust Against Environmental Interferences such as Oil, Water, Dirt, or Dust
- Minimal External Components
- Magnet-Free Operation
- Operating Temperature:  $-40^{\circ}\text{C}$  to  $+125^{\circ}\text{C}$

## 2 Applications

- High-Speed Gear Counting
- High-Speed Event Counting
- Motor Speed Sensing
- Knobs and Dials for Appliances, Automotive, and Consumer Applications
- HMI for Appliances, Automotive, and Consumer Applications
- Buttons and Keypads
- Motor Control
- Metal Detection

## 4 Simplified Schematic

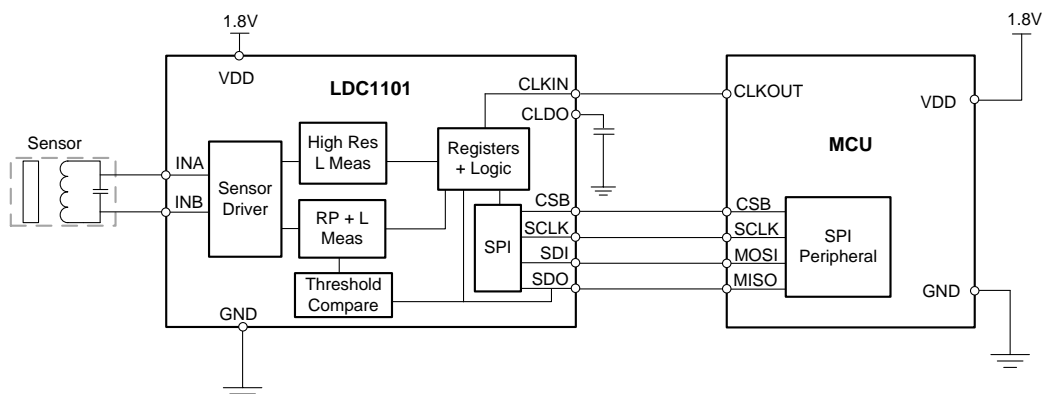

## 3 Description

The LDC1101 is a 1.8-V to 3.3-V, high-resolution inductance-to-digital converter for short-range, high-speed, contactless sensing of position, rotation, or motion, enabling reliable, accurate measurements even in the presence of dust or dirt, making it ideal for open or harsh environments.

The LDC1101 features dual inductive measurement cores, allowing for  $> 150$  kSPS 16-bit  $R_p$  and L measurements simultaneous with a high-resolution L measurement which can sample at  $> 180$  kSPS with a resolution of up to 24 bits. The LDC1101 includes a threshold-compare function which can be dynamically updated while the device is running.

Inductive sensing technology enables precise measurement of linear/angular position, displacement, motion, compression, vibration, metal composition, and many other applications in markets including automotive, consumer, computer, industrial, medical, and communications. Inductive sensing offers better performance and reliability at lower cost than other, competing solutions.

The LDC1101 offers these benefits of inductive sensing in a small 3-mm  $\times$  3-mm 10-pin VSON package. The LDC1101 can be easily configured by a microcontroller using the 4-pin SPI™.

### Device Information<sup>(1)</sup>

PART NUMBER	PACKAGE	BODY SIZE (NOM)
LDC1101	VSON (10)	3.00 mm $\times$ 3.00 mm

(1) For all available packages, see the orderable addendum at the end of the data sheet.





**Changes from Original (May 2015) to Revision A****Page**

- 
- Added full datasheet to replace the Product Preview ..... [1](#)
-

## 6 Pin Configuration and Functions

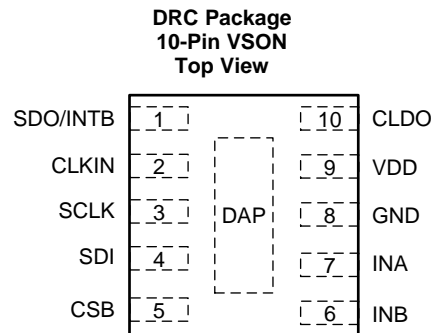

### Pin Functions

PIN		TYPE <sup>(1)</sup>	DESCRIPTION
NAME	NO.		
CLDO	10	P	Internal LDO bypassing pin. A 15-nF capacitor must be connected from this pin to GND.
CLKIN	2	I	External time-base clock input
CSB	5	I	SPI CSB. Multiple devices can be connected on the same SPI bus and CSB can be used to uniquely select desired device. CSB must be toggled for proper device operation.
DAP	–	–	Connect to ground for improved thermal performance <sup>(2)</sup>
GND	8	G	Ground
INA	7	A	External LC sensor – connect to external LC sensor
INB	6	A	External LC sensor – connect to external LC sensor
SCLK	3	I	SPI clock input
SDI	4	I	SPI data input – connect to MOSI of SPI master
SDO/INTB	1	O	SPI data output/INTB – Connect to MISO of SPI master. When CSB is high, this pin is High-Z. Alternatively, this pin can be configured to function as INTB
VDD	9	P	Power supply

(1) P= Power, G=Ground, I=Input, O=Output, A=Analog

(2) There is an internal electrical connection between the exposed Die Attach Pad (DAP) and the GND pin of the device. Although the DAP can be left floating, for best performance the DAP must be connected to the same potential as the GND pin of the device. Do not use the DAP as the primary ground for the device. The device GND pin must always be connected to ground.

## 7 Specifications

### 7.1 Absolute Maximum Ratings

over operating free-air temperature range (unless otherwise noted)<sup>(1)</sup>

		MIN	MAX	UNIT
V <sub>DD</sub>	Supply voltage range		3.6	V
V <sub>i</sub>	Voltage on INA, INB	-0.3	2.3	V
	Voltage on CLDO	-0.3	1.9	V
	Voltage on any other pin <sup>(2)</sup>	-0.3	V <sub>DD</sub> + 0.3	V
T <sub>J</sub>	Junction temperature	-55	125	°C
T <sub>stg</sub>	Storage temperature	-65	125	°C

- (1) Stresses beyond those listed under *Absolute Maximum Ratings* may cause permanent damage to the device. These are stress ratings only, which do not imply functional operation of the device at these or any other conditions beyond those indicated under *Recommended Operating Conditions*. Exposure to absolute-maximum-rated conditions for extended periods may affect device reliability.
- (2) Maximum voltage across any two pins is V<sub>DD</sub>+0.3.

### 7.2 ESD Ratings

			VALUE	UNIT
V <sub>(ESD)</sub>	Electrostatic discharge	Human-body model (HBM), per ANSI/ESDA/JEDEC JS-001 <sup>(1)</sup>	±2000	V
		Charged-device model (CDM), per JEDEC specification JESD22-C101 <sup>(2)</sup>	±1000	

- (1) JEDEC document JEP155 states that 500-V HBM allows safe manufacturing with a standard ESD control process.
- (2) JEDEC document JEP157 states that 250-V CDM allows safe manufacturing with a standard ESD control process.

### 7.3 Recommended Operating Conditions

over operating free-air temperature range (unless otherwise noted)

		MIN	NOM	MAX	UNIT
V <sub>DD</sub>	Supply voltage	1.71		3.46	V
T <sub>J</sub>	Junction temperature	-40		125	°C

### 7.4 Thermal Information

THERMAL METRIC <sup>(1)</sup>		LDC1101	UNIT
		DRC (VSON)	
		10 PINS	
R <sub>θJA</sub>	Junction-to-ambient thermal resistance	44.2	°C/W
R <sub>θJC(top)</sub>	Junction-to-case (top) thermal resistance	50.1	°C/W
R <sub>θJB</sub>	Junction-to-board thermal resistance	19.6	°C/W
ψ <sub>JT</sub>	Junction-to-top characterization parameter	0.7	°C/W
ψ <sub>JB</sub>	Junction-to-board characterization parameter	19.8	°C/W
R <sub>θJC(bot)</sub>	Junction-to-case (bottom) thermal resistance	4.4	°C/W

- (1) For more information about traditional and new thermal metrics, see the *Semiconductor and IC Package Thermal Metrics* application report, [SPRA953](#).

## 7.5 Electrical Characteristics

 Over recommended operating conditions unless otherwise noted.  $V_{DD} = 1.8\text{ V}$ ,  $T_A = 25^\circ\text{C}$ .

PARAMETER		TEST CONDITION <sup>(1)</sup>	MIN <sup>(2)</sup>	TYP <sup>(3)</sup>	MAX <sup>(2)</sup>	UNIT
<b>POWER</b>						
$V_{DD}$	Supply voltage		1.71		3.46	V
$I_{DD}$	Supply current	START_CONFIG= 0x00, no sensor connected		1.9	2.7	mA
$I_{DDS}$	Supply current including sensor current	$f_{CLKIN} = 16\text{ MHz}$ , $f_{SENSOR} = 2\text{ MHz}$ , START_CONFIG = 0x00		3.2		mA
$I_{DSSL}$	Sleep mode supply current	START_CONFIG =0x01		135	180	$\mu\text{A}$
$I_{SD}$	Shutdown mode supply current			1.4	6.7	$\mu\text{A}$
<b>SENSOR</b>						
	$R_p$ Measurement part-to-part variation	RESP_TIME= 6144, D_CONFIG=0x00, ALT_CONFIG=0x00, START_CONFIG = 0x00, $f_{SENSOR} = 2\text{ MHz}$		1%		
$I_{SENSORMAX}$	Sensor maximum current drive	RP_MIN = b111, START_CONFIG=0x00, D_CONFIG=0x00, ALT_CONFIG=0x00	0.598	0.6	0.602	mA
$I_{SENSORMIN}$	Sensor minimum current drive	RP_MAX = b000, HIGH_Q_SENSOR=b0, START_CONFIG=0x00, D_CONFIG=0x00, ALT_CONFIG=0x00		4.7		$\mu\text{A}$
$f_{SENSOR}$	Sensor resonant frequency	Device settings and Sensor compliant as detailed in <a href="#">LDC1101 <math>R_p</math> Configuration</a>	0.5		10	MHz
$RP_{RES}$	$R_p$ Measurement resolution			16		bits
$L_{RES}$	Inductance sensing resolution – $R_p+L$ Mode			16		bits
	Inductance sensing resolution – LHR Mode			24		bits
$A_{OSC}$	Sensor oscillation amplitude	INA – INB, START_CONFIG=0x00, D_CONFIG=0x00, ALT_CONFIG=0x00		1.2		$V_{PP}$
<b>DETECTION</b>						
$t_{S\_MIN}$	Minimum response time (RP+L mode)	$R_p+L$ Mode, RESP_TIME=b010		$192 \div f_{SENSOR}$		s
$t_{S\_MAX}$	Maximum response time (RP+L mode)	$R_p+L$ Mode, RESP_TIME=b111		$6144 \div f_{SENSOR}$		s
$T_{S\_MAX}$	High Res L maximum measurement interval	LHR_REF_COUNT=0xFFFF, START_CONFIG=0x00		$(2^{20}+39) \div f_{CLKIN}$		s
$SR_{MAXRP}$	RP+L Mode maximum sample rate	$f_{CLKIN}=16\text{ MHz}$ , $f_{SENSOR} = 10\text{ MHz}$ , RESP_TIME=b010		156.25		kSPS
$SR_{MAXL}$	High Res L Mode maximum sample rate	High Resolution L Mode, LHR_REF_COUNT=0x0002, $f_{CLKIN}=16\text{ MHz}$		183.8		kSPS
<b>FREQUENCY REFERENCE</b>						
$f_{CLKIN}$	Reference input frequency		1		16	MHz
$DC_{fin}$	Reference duty cycle		40%		60%	
$V_{IH}$	Input high voltage (Logic “1”)			$0.8 \times V_{DD}$		V
$V_{IL}$	Input low voltage (Logic “0”)			$0.2 \times V_{DD}$		V

- Register values are represented as either binary (b is the prefix to the digits), or hexadecimal (0x is the prefix to the digits). Decimal values have no prefix.
- Limits are ensured by testing, design, or statistical analysis at  $25^\circ\text{C}$ . Limits over the operating temperature range are ensured through correlation using statistical quality control (SQC) method.
- Typical values represent the most likely parametric norm as determined at the time of characterization. Actual typical values may vary over time and will also depend on the application and configuration. The typical values are not tested and are not verified on shipped production material.

## 7.6 Digital Interface

PARAMETER		MIN	TYP	MAX	UNIT
<b>VOLTAGE LEVELS</b>					
$V_{IH}$	Input high voltage (Logic “1”)	$0.8 \times V_{DD}$			V
$V_{IL}$	Input low voltage (Logic “0”)			$0.2 \times V_{DD}$	V
$V_{OH}$	Output high voltage (Logic “1”, $I_{SOURCE} = 400\ \mu\text{A}$ )		$V_{DD}-0.3$		V
$V_{OL}$	Output low voltage (Logic “0”, $I_{SINK} = 400\ \mu\text{A}$ )			0.3	V
$I_{OHL}$	Digital IO leakage current	-500		500	nA

## 7.7 Timing Requirements

See [Figure 1](#) and [Figure 2](#).

		MIN	NOM	MAX	UNIT
$t_{START}$	Start-up time from shutdown to sleep		0.8		ms
$t_{WAKE}$	Wake-up time (from completion of SPI to conversion start; does not include sensor settling time)		0.04		ms
<b>INTERFACE TIMING REQUIREMENTS<sup>(1)</sup></b>					
$f_{SCLK}$	Serial clock frequency			8	MHz
$t_{WH}$	SCLK pulse-width high	$0.4f_{SCLK}$			s
$t_{WL}$	SCLK pulse-width low	$0.4f_{SCLK}$			s
$t_{SU}$	SDI setup time	10			ns
$t_H$	SDI hold time	10			ns
$t_{ODZ}$	SDO driven-to-tristate time			25	ns
$t_{OZD}$	SDO tristate-to-driven time			25	ns
$t_{OD}$	SDO output delay time			20	ns
$t_{SU}(CS)$	CSB setup time	20			ns
$t_H(CS)$	CSB hold time	20			ns
$t_{IAG}$	CSB inter-access interval	100			ns
$t_W(DRDY)$	Data ready pulse width		$1/f_{SENSOR}$		ns

(1) Unless otherwise noted, all limits specified at  $T_A = 25^\circ\text{C}$ ,  $V_{DD} = 1.8\text{ V}$ , 10-pF capacitive load in parallel with a 10-k $\Omega$  load on the SDO pin. Specified by design; not production tested.

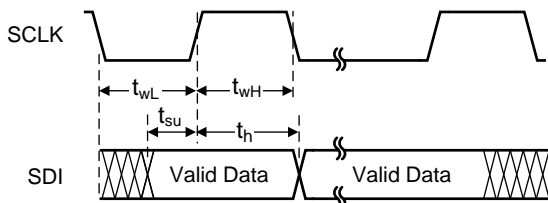

Figure 1. Write Timing Diagram

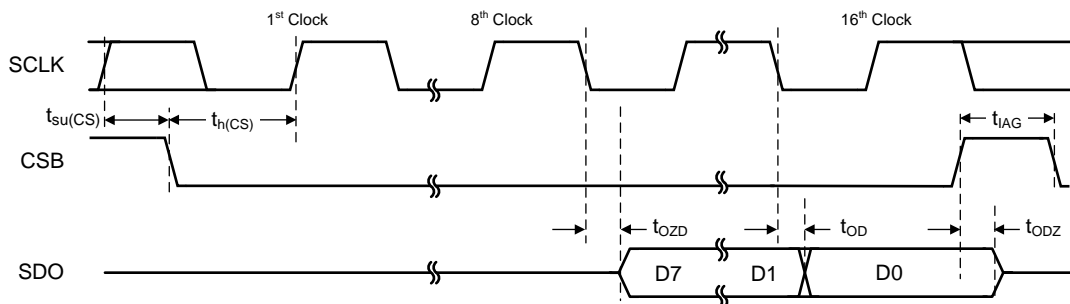
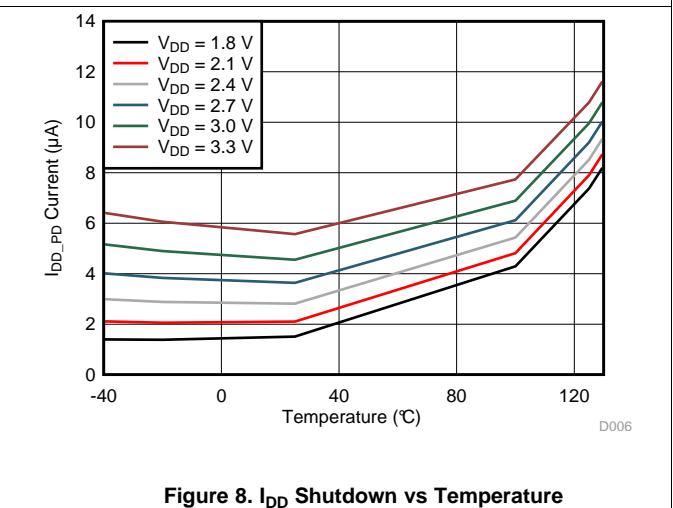
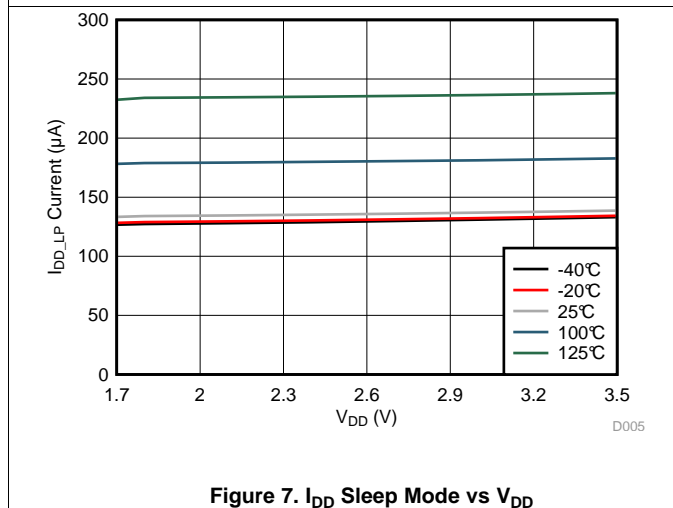
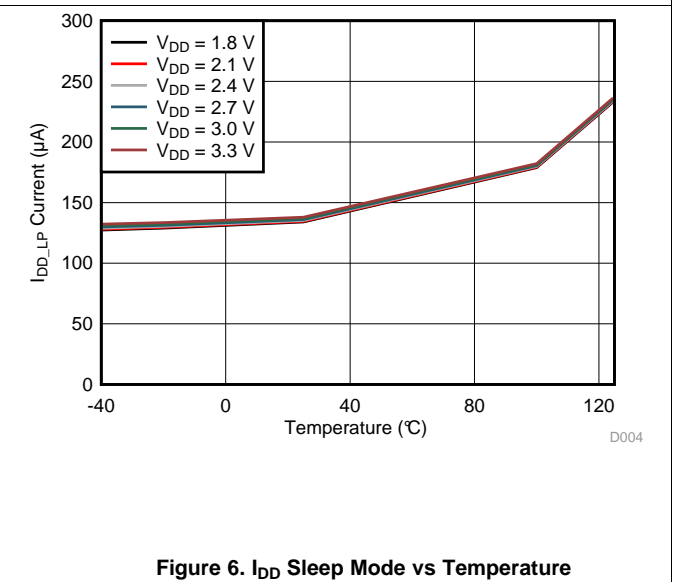
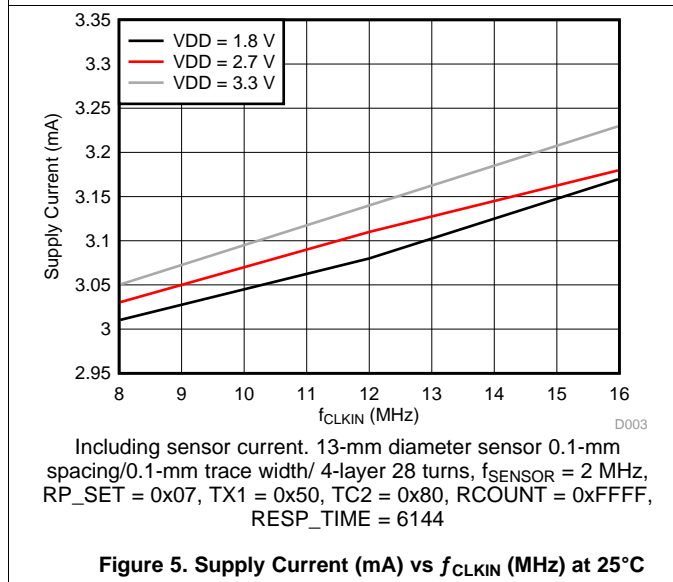
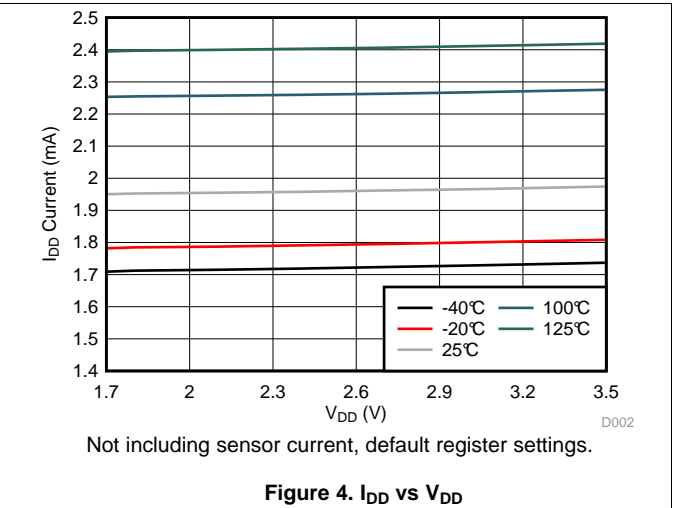
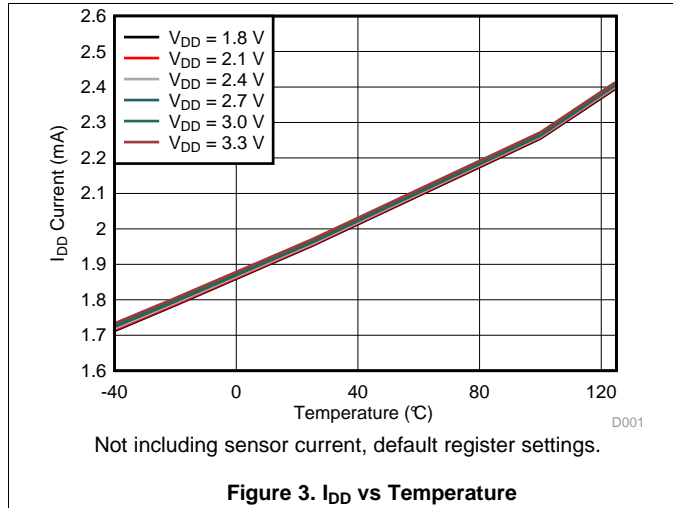

Figure 2. Read Timing Diagram

### 7.8 Typical Characteristics



Typical Characteristics (continued)

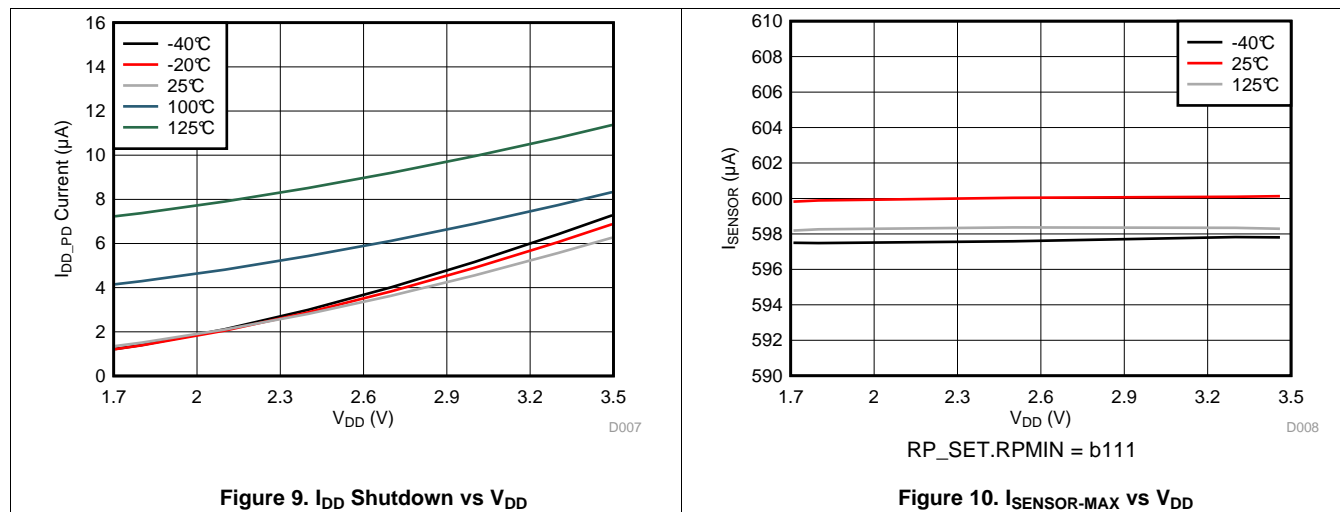

Figure 9.  $I_{DD}$  Shutdown vs  $V_{DD}$

Figure 10.  $I_{SENSOR-MAX}$  vs  $V_{DD}$

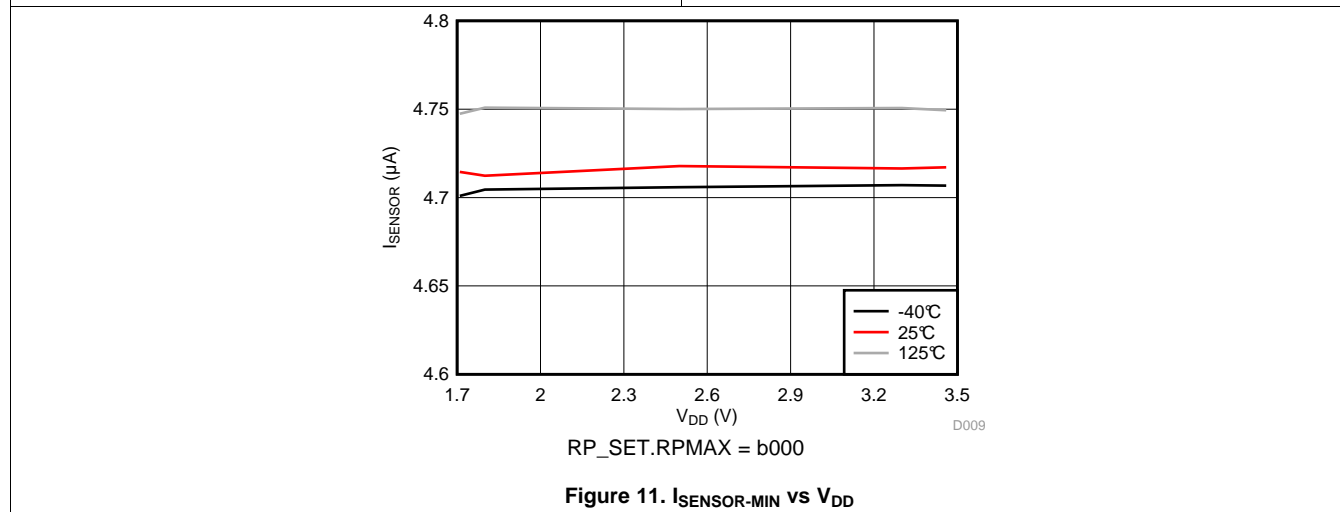

Figure 11.  $I_{SENSOR-MIN}$  vs  $V_{DD}$

## 8 Detailed Description

### 8.1 Overview

The LDC1101 is an inductance-to-digital converter which can simultaneously measure the impedance and resonant frequency of an LC resonator. The high resolution measurement capability enables this device to be used to directly measure changes in physical systems, allowing the resonator to sense the proximity and movement of conductive materials.

The LDC1101 measures the impedance and resonant frequency by regulating the oscillation amplitude in a closed-loop configuration at a constant level, while monitoring the energy dissipated by the resonator. By monitoring the amount of power injected into the resonator, the LDC1101 can determine the equivalent parallel resistance of the resonator,  $R_p$ , which it returns as a digital value.

In addition, the LDC1101 device also measures the oscillation frequency of the LC circuit by comparing the sensor frequency to a provided reference frequency. The sensor frequency can then be used to determine the inductance of the LC circuit.

The threshold comparator block can compare the  $R_p+L$  conversion results versus a programmable threshold. With the threshold registers programmed and comparator enabled, the LDC1101 can provide a switch output, reported as a high/low level on the INTB/SDO pin.

The LDC1101 device supports a wide range of LC combinations with oscillation frequencies ranging from 500 kHz to 10 MHz and  $R_p$  ranging from 1.25 k $\Omega$  to 90 k $\Omega$ . The device is configured and conversion results retrieved through a simple 4-wire SPI. The power supply for the device can range from 1.8 V – 5% to 3.3 V + 5%. The only external components necessary for operation are a 15 nF capacitor for internal LDO bypassing and supply bypassing for VDD.

### 8.2 Functional Block Diagram

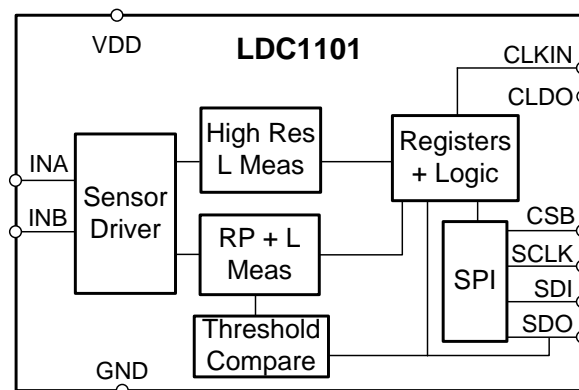

### 8.3 Feature Description

#### 8.3.1 Sensor Driver

The LDC1101 can drive a sensor with a resonant frequency of 500 kHz to 10 MHz with an  $R_p$  in the range of 1.25 k $\Omega$  to 90 k $\Omega$ . The nominal sensor amplitude is 1.2 V. The sensor Q should be at least 10 for  $R_p$  measurements. The inductive sensor must be connected across the INA and INB pins. The resonant frequency of the sensor is set by:

$$f_{\text{SENSOR}} (\text{Hz}) = \frac{1}{2\pi\sqrt{L \times C}}$$

where

- L is the sensor inductance in Henrys, and
- C is the sensor parallel capacitance in Farads.

(1)

## 8.4 Device Functional Modes

### 8.4.1 Measurement Modes

The LDC1101 features two independent measurement subsystems to measure the impedance and resonant frequency of an attached sensor. The  $R_p+L$  subsystem can simultaneously measure the impedance and resonant frequency of an LC resonator, with up to 16 bits of resolution for each parameter. Refer to  [\$R\_p+L\$  Measurement Mode](#) for more information on the  $R_p+L$  measurement functionality.

The High Resolution L (LHR) subsystem measures the sensor resonant frequency with up to 24 bits of resolution. The effective resolution is a function of the sample rate and the reference frequency supplied on the CLKIN pin. Refer to [High Resolution L \(LHR\) Measurement Mode](#) for more information on the LHR measurement functionality.

Both measurement subsystems can convert simultaneously but at different sample intervals – the completion of an  $R_p+L$  conversion will be asynchronous to the completion of a LHR conversion.

**Table 1. Comparison of Measurement Modes**

	<b>RP+L Mode</b>	<b>LHR Mode</b>
$R_p$ Measurement Resolution	16 bits	N/A
L Measurement Resolution	16 bits	24 bits
Sample Rate configuration	Varies with $f_{\text{SENSOR}}$ , set by RESP_TIME	Fixed and set by RCOUNT field and $f_{\text{CLKIN}}$
Sample rate at highest resolution (SPS)	244	15.3
Maximum Sample Rate (kSPS)	156.25	183.9
L Resolution at Maximum Sample rate	6.7 bits	6.5 bits
Switch Output on SDO/INTB	Available for $R_p$ or L output code	N/A

### 8.4.2 $R_p+L$ Measurement Mode

In  $R_p+L$  mode, the LDC1101 will simultaneously measure the impedance and resonant frequency of the attached sensor. The device accomplishes this task by regulating the oscillation amplitude in a closed-loop configuration to a constant level, while monitoring the energy dissipated by the resonator. By monitoring the amount of power injected into the resonator, the LDC1101 device can determine the value of  $R_p$ . The device returns this value as a digital value which is proportional to  $R_p$ . In addition, the LDC1101 device can also measure the oscillation frequency of the LC circuit, by counting the number of cycles of a reference frequency. The measured sensor frequency can be used to determine the inductance of the LC circuit.

#### 8.4.2.1 $R_{pMIN}$ and $R_{pMAX}$

The variation of  $R_p$  in a given system is typically much smaller than maximum range of 1.25 k $\Omega$  to >90 k $\Omega$  supported by the LDC1101. To achieve better resolution for systems with smaller  $R_p$  ranges, the LDC1101 device offers a programmable  $R_p$  range.

The LDC1101 uses adjustable current drives to scale the  $R_p$  measurement range; by setting a tighter current range a higher accuracy  $R_p$  measurement can be performed. This functionality can be considered as a variable gain amplifier (VGA) front end to an ADC. The current ranges are configured in the  $R_{pMIN}$  and  $R_{pMAX}$  fields of register RP\_SET (address 0x01). Refer to [LDC1101  \$R\_p\$  Configuration](#) for instructions to optimize these settings.

#### 8.4.2.2 Programmable Internal Time Constants

The LDC1101 utilizes internal programmable registers to configure time constants necessary for sensor oscillation. These internal time constants must be configured for  $R_p$  measurements. Refer to [Setting Internal Time Constant 1](#) and [Setting Internal Time Constant 2](#) for instructions on how to configure them for a given system.

#### 8.4.2.3 $R_p+L$ Mode Measurement Sample Rate

The LDC1101 provides an adjustable sample rate for the  $R_p+L$  conversion, where longer conversion times have higher resolution. Refer to  [\$R\_p+L\$  Sample Rate Configuration With RESP\\_TIME](#) for more details.

### 8.4.3 High Resolution L (LHR) Measurement Mode

The High Resolution L measurement (LHR) subsystem provides a high-resolution inductance (L) measurement of up to 24 bits. This L measurement can be configured to provide a higher resolution measurement than the measurement returned from the RP+L subsystem. The LHR subsystem also provides a constant conversion time interval, whereas the RP+L conversion interval is a function of the sensor frequency. The LHR measurement runs asynchronously with respect to the RP+L measurement. For more information on LHR mode resolution, refer to *Optimizing L Measurement Resolution for the LDC161x and LDC1101* ([SNOA944](#)).

### 8.4.4 Reference Count Setting

The LHR sample rate is set by the Reference Count (LHR\_RCOUNT) setting (registers 0x30 and 0x31). The LHR conversion resolution is proportional to the programmed RCOUNT value. With the maximum supported 16-MHz CLKIN input, the LDC1101 conversion interval can be set from 5.44  $\mu$ s to 65.54 ms in 1- $\mu$ s increments. Note that longer conversion intervals produce more accurate LHR measurements. Refer to [LHR Sample Rate Configuration With RCOUNT](#) for more details.

### 8.4.5 L-Only Measurement Operation

The LDC1101 can disable the  $R_P$  measurement to perform a more stable L measurement. To enable this mode, set:

- ALT\_CONFIG.LOPTIMAL(register 0x05-bit0) = 1
- D\_CONFIG.DOK\_REPORT (register 0x0C-bit0) = 1

When this mode is used,  $R_P$  measurement results are not valid.

### 8.4.6 Minimum Sensor Frequency and Watchdog Setting

The LDC1101 can report an error condition if the sensor oscillation stops. Refer to [MIN\\_FREQ and Watchdog Configuration](#) for information on the configuration of the watchdog.

### 8.4.7 Low Power Modes

When continuous LDC conversions are not required, the LDC1101 supports two reduced power modes. In Sleep mode, the LDC1101 retains register settings and can quickly enter active mode for conversions. In Shutdown mode, power consumption is significantly lower, although the device configuration is not retained. While in either low power mode, the LDC1101 does not perform conversions.

#### 8.4.7.1 Shutdown Mode

Shutdown mode is the lowest power state for the LDC1101. Note that entering SD mode will reset all registers to their default state, and so the device must have its registers rewritten. To enter Shutdown, perform the following sequence:

1. Set ALT\_CONFIG.SHUTDOWN\_EN = 1 (register 0x05-bit[1]).
2. Stop toggling the CLKIN pin input and drive the CLKIN pin Low.
3. Set START\_CONFIG.FUNC\_MODE = b10 (register 0x0B:bits[1:0]). This register can be written while the LDC1101 is in active mode; on completion of the register write the LDC1101 will enter shutdown.

To exit Shutdown mode, resume toggling the clock input on the CLKIN pin; the LDC1101 transitions to Sleep mode with the default register values.

While in Shutdown mode, no conversions are performed. In addition, entering Shutdown mode clears the status registers; if an error condition is present it is reported when the device exits Shutdown mode.

#### 8.4.7.2 Sleep Mode

Sleep mode is entered by setting START\_CONFIG.FUNC\_MODE = b01 (register 0x0B:bits[1:0]). While in this mode, the register contents are maintained. To exit Sleep mode and start active conversions, set START\_CONFIG.FUNC\_MODE = b00. While in Sleep mode the SPI interface is functional so that register reads and writes can be performed.

On power-up or exiting Shutdown mode, the LDC1101 is in Sleep mode.

Configuring the LDC1101 must be done while the device is in Sleep mode. If a setting on the LDC1101 needs to be changed, return the device to Sleep mode, change the appropriate register, and then return the LDC1101 to conversion mode. The registers related to INTB reporting can be changed while the LDC1101 is in active mode. Refer to [INTB Reporting on SDO](#) for more details.

### 8.4.8 Status Reporting

The LDC1101 provides 2 status registers, STATUS and LHR\_STATUS, to report on the device and sensor condition.

**Table 2. STATUS Fields**

NAME	FIELD	FUNCTION
NO_SENSOR_OSC	7	When the resonance impedance of the sensor, $R_p$ , drops below the programmed $R_{p\_MIN}$ , the sensor oscillation may stop. This condition is reported by STATUS:NO_SENSOR_OSC (register 0x20-bit7). This condition could occur when a target comes too close to the sensor or if RP_SET:RP_MIN (register 0x01-bits[2:0]) is set too high.
DRDYB	6	RP+L Data Ready - reports completion of RP+L conversion results
RP_HIN	5	RP+L threshold – refer to <a href="#">Comparator Functionality</a> for details
RP_HI_LON	4	
L_HIN	3	
L_HI_LON	2	
POR_READ	0	Device in Power-On Reset – device should only be configured when POR_READ = 0.

The LHR\_STATUS register (register 0x3B) reports on LHR functionality.

### 8.4.9 Switch Functionality and INTB Reporting

The SDO pin can generate INTB, a signal which corresponds to device status. INTB can report conversion completion or provide a comparator output, in which the LDC conversion results are internally compared to programmable thresholds. Refer to [INTB Reporting on SDO](#) for details.

## 8.5 Programming

### 8.5.1 SPI Programming

The LDC1101 uses SPI to configure the internal registers. It is necessary to configure the LDC1101 while in Sleep mode. If a setting on the LDC1101 needs to be changed, return the device to Sleep mode, change the appropriate register, and then return the LDC1101 to conversion mode. CSB must go low before accessing first address. If the number of SCLK pulses is less than 16, a register write command does not change the contents of the addressed register.

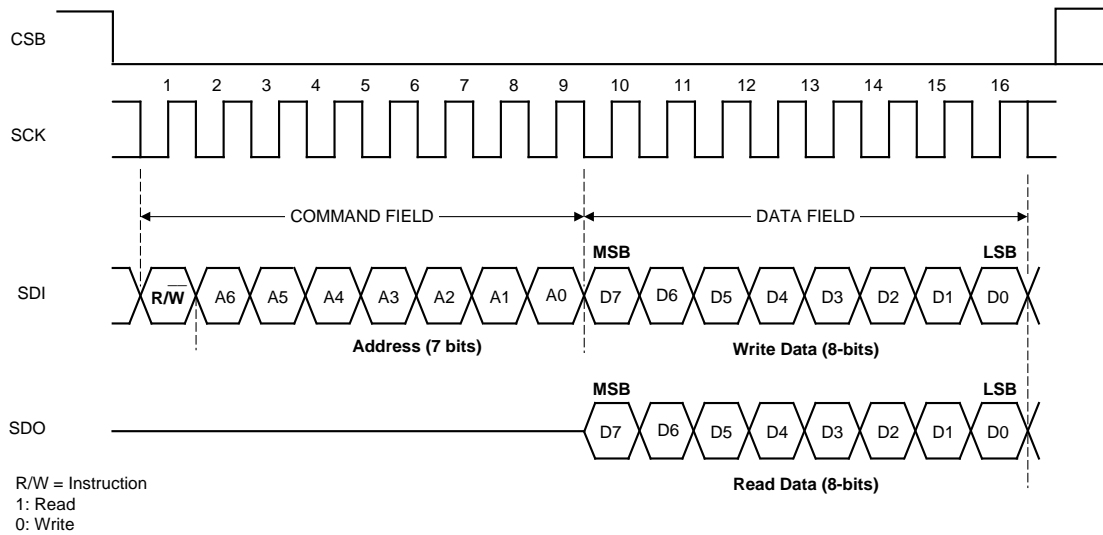
**Programming (continued)**

**Figure 12. SPI Transaction Format**

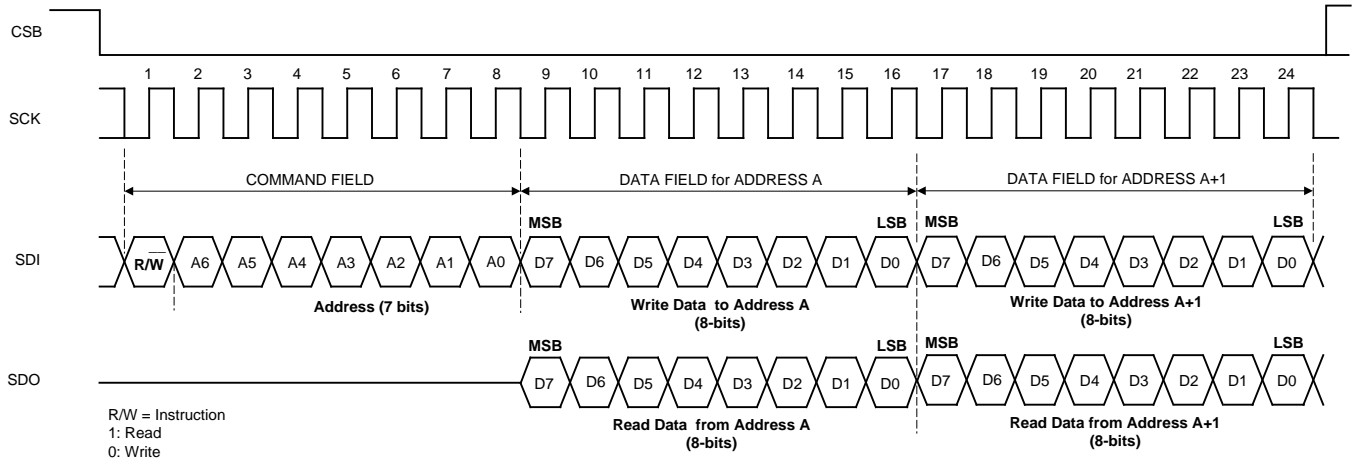
The LDC1101 supports an extended SPI transaction, in which CSB is held low and sequential register addresses can be written or read. After the first register transaction, each additional 8 SCLK pulses addresses the next register, reading or writing based on the initial R/W flag in the initial command. A register write command takes effect on the 8th clock pulse. Two or more registers can be programmed using this method. The register address must not increment above 0x3F.

**Figure 13. Extended SPI Transaction**

## 8.6 Register Maps

**Table 3. Register List**

ADDRESS	NAME	DEFAULT VALUE	DESCRIPTION
0x01	RP_SET	0x07	Configure R <sub>P</sub> Measurement Dynamic Range
0x02	TC1	0x90	Configure Internal Time Constant 1
0x03	TC2	0xA0	Configure Internal Time Constant 2
0x04	DIG_CONFIG	0x03	Configure RP+L conversion interval
0x05	ALT_CONFIG	0x00	Configure additional device settings
0x06	RP_THRESH_H_LSB	0x00	RP_THRESHOLD High Setting – bits 7:0. This register can be modified while the LDC1101 is in active mode.
0x07	RP_THRESH_H_MSB	0x00	RP_THRESHOLD High Setting – bits 15:8. This register can be modified while the LDC1101 is in active mode.
0x08	RP_THRESH_L_LSB	0x00	RP_THRESHOLD Low Setting – bits 7:0. This register can be modified while the LDC1101 is in active mode.
0x09	RP_THRESH_L_MSB	0x00	RP_THRESHOLD Low Setting – bits 15:8. This register can be modified while the LDC1101 is in active mode.
0x0A	INTB_MODE	0x00	Configure INTB reporting on SDO pin. This register can be modified while the LDC1101 is in active mode.
0x0B	START_CONFIG	0x01	Configure Power State
0x0C	D_CONF	0x00	Sensor Amplitude Control Requirement
0x16	L_THRESH_HI_LSB	0x00	L_THRESHOLD High Setting – bits 7:0. This register can be modified while the LDC1101 is in active mode.
0x17	L_THRESH_HI_MSB	0x00	L_THRESHOLD High Setting – bits 15:8. This register can be modified while the LDC1101 is in active mode.
0x18	L_THRESH_LO_LSB	0x00	L_THRESHOLD Low Setting – bits 7:0. This register can be modified while the LDC1101 is in active mode.
0x19	L_THRESH_LO_MSB	0x00	L_THRESHOLD Low Setting – bits 15:8. This register can be modified while the LDC1101 is in active mode.
0x20	STATUS	0x00	Report RP+L measurement status
0x21	RP_DATA_LSB	0x00	R <sub>P</sub> Conversion Result Data Output - bits 7:0
0x22	RP_DATA_MSB	0x00	R <sub>P</sub> Conversion Result Data Output - bits 15:8
0x23	L_DATA_LSB	0x00	L Conversion Result Data Output - bits 7:0
0x24	L_DATA_MSB	0x00	L Conversion Result Data Output - bits 15:8
0x30	LHR_RCOUNT_LSB	0x00	High Resolution L Reference Count – bits 7:0
0x31	LHR_RCOUNT_MSB	0x00	High Resolution L Reference Count – bits 15:8
0x32	LHR_OFFSET_LSB	0x00	High Resolution L Offset – bits 7:0
0x33	LHR_OFFSET_MSB	0x00	High Resolution L Offset – bits 15:8
0x34	LHR_CONFIG	0x00	High Resolution L Configuration
0x38	LHR_DATA_LSB	0x00	High Resolution L Conversion Result Data output - bits 7:0
0x39	LHR_DATA_MID	0x00	High Resolution L Conversion Result Data output - bits 15:8
0x3A	LHR_DATA_MSB	0x00	High Resolution L Conversion Result Data output - bits 23:16
0x3B	LHR_STATUS	0x00	High Resolution L Measurement Status
0x3E	RID	0x02	Device RID value
0x3F	CHIP_ID	0xD4	Device ID value

### 8.6.1 Individual Register Listings

Fields indicated with Reserved must be written only with indicated values. Improper device operation may occur otherwise. The R/W column indicates the Read-Write status of the corresponding field. A 'R/W' entry indicates read and write capability, a 'R' indicates read-only, and a 'W' indicates write-only.

### 8.6.2 Register RP\_SET (address = 0x01) [reset = 0x07]

**Figure 14. Register RP\_SET**

7	6	5	4	3	2	1	0
HIGH_Q_SENS OR	RP_MAX			RESERVED	RP_MIN		
R/W	R/W			R/W	R/W		

LEGEND: R/W = Read/Write; R = Read only; -n = value after reset

**Table 4. Register RP\_SET Field Descriptions**

Bit	Field	Type	Reset	Description
7	HIGH_Q_SENSOR	R/W	0	<b>High Q Sensor optimization -RPMAX_DIS</b> This setting improves the $R_p$ measurement accuracy for very high Q coils by driving 0A as the $R_{pMAX}$ current drive. Typically, sensors with $Q > 50$ can benefit from enabling this mode. b0: Programmed RP_MAX is driven ( <b>default value</b> ) b1: RP_MAX current is ignored; current drive is off.
6:4	RP_MAX	R/W	b000	<b>RP_MAX Setting</b> Set the maximum input dynamic range for the sensor $R_p$ measurement. The programmed RP_MIN setting must not exceed the programmed RP_MAX setting. b000: RPMAX = 96 k $\Omega$ ( <b>default value</b> ) b001: RPMAX = 48 k $\Omega$ b010: RPMAX = 24 k $\Omega$ b011: RPMAX = 12 k $\Omega$ b100: RPMAX = 6 k $\Omega$ b101: RPMAX = 3 k $\Omega$ b110: RPMAX = 1.5 k $\Omega$ b111: RPMAX = 0.75 k $\Omega$
3	RESERVED	R/W	0	<b>Reserved.</b> Set to 0
2:0	RP_MIN	R/W	b111	<b>RP_MIN Setting</b> Set the minimum input dynamic range for the sensor $R_p$ measurement. The programmed RP_MIN setting must not exceed the programmed RP_MAX setting. b000: RPMIN = 96 k $\Omega$ b001: RPMIN = 48 k $\Omega$ b010: RPMIN = 24 k $\Omega$ b011: RPMIN = 12 k $\Omega$ b100: RPMIN = 6 k $\Omega$ b101: RPMIN = 3 k $\Omega$ b110: RPMIN = 1.5 k $\Omega$ b111: RPMIN = 0.75 k $\Omega$ ( <b>default value</b> )

**8.6.3 Register TC1 (address = 0x02) [reset = 0x90]**
**Figure 15. Register TC1**

7	6	5	4	3	2	1	0
C1		RESERVED				R1	
R/W		R/W			R/W		

LEGEND: R/W = Read/Write; R = Read only; -n = value after reset

**Table 5. Register TC1 Field Descriptions**

Bit	Field	Type	Reset	Description
7:6	C1	R/W	b10	<b>Internal Time Constant 1 Capacitance</b> This sets the capacitive component used to configure internal time constant 1. Refer to <a href="#">Setting Internal Time Constant 1</a> for more details. b00: C1 = 0.75 pF b01: C1 = 1.5 pF b10: C1 = 3 pF ( <b>default value</b> ) b11: C1 = 6 pF
5	RESERVED	R/W	0	<b>Reserved.</b> Set to 0
4:0	R1	R/W	b1'000 0	<b>Internal Time Constant 1 Resistance</b> This sets the resistive component used to configure internal time constant 1. Refer to <a href="#">Setting Internal Time Constant 1</a> for configuration details. $R1(\Omega) = -12.77 \text{ k}\Omega \times R1 + 417 \text{ k}\Omega$ Valid Values: [b0'0000:b1'1111] b0'0000: R <sub>1</sub> = 417 kΩ b1'0000: R <sub>1</sub> = 212.7kΩ ( <b>default value</b> ) b1'1111: R <sub>1</sub> = 21.1 kΩ

**8.6.4 Register TC2 (address = 0x03) [reset = 0xA0]**
**Figure 16. Register TC2**

7	6	5	4	3	2	1	0
C2					R2		
R/W		R/W			R/W		

LEGEND: R/W = Read/Write; R = Read only; -n = value after reset

**Table 6. Register TC2 Field Descriptions**

Bit	Field	Type	Reset	Description
7:6	C2	R/W	b10	<b>Internal Time Constant 2 Capacitance</b> This sets the capacitive component used to configure internal time constant 2. Refer to <a href="#">Setting Internal Time Constant 2</a> for configuration details. b00: C2 = 3 pF b01: C2 = 6 pF b10: C2 = 12 pF ( <b>default value</b> ) b11: C2 = 24 pF
5:0	R2	R/W	b10'000 0	<b>Internal Time Constant 2 Resistance</b> This sets the resistive component used to configure internal time constant 2. Refer to <a href="#">Setting Internal Time Constant 2</a> for details. $R2(\Omega) = -12.77 \text{ k}\Omega \times R2 + 835 \text{ k}\Omega$ Valid Values: [b00'0000:b11'1111] b00'0000: R <sub>2</sub> = 835kΩ b10'0000: R <sub>2</sub> = 426.4 kΩ ( <b>default value</b> ) b11'1111: R <sub>2</sub> = 30.5 kΩ

**8.6.5 Register DIG\_CONF (address = 0x04) [reset = 0x03]**
**Figure 17. Register DIG\_CONF**

7	6	5	4	3	2	1	0
MIN_FREQ				RESERVED	RESP_TIME		
R/W				R/W			

LEGEND: R/W = Read/Write; R = Read only; -n = value after reset

**Table 7. Register DIG\_CONF Field Descriptions**

Bit	Field	Type	Reset	Description
7:4	MIN_FREQ	R/W	0x0	<b>Sensor Minimum Frequency</b> Configure this register based on the lowest possible sensor frequency. This is typically when the target is providing minimum interaction with the sensor, although with some steel and ferrite targets, the minimum sensor frequency occurs with maximum target interaction. This setting should include any additional effects which reduce the sensor frequency, including temperature shifts and sensor capacitor variation. $MIN\_FREQ = 16 - (8 \text{ MHz} \div f_{\text{SENSORMIN}})$ b0000: $f_{\text{SENSORMIN}} = 500 \text{ kHz}$ ( <b>default value</b> ) b1111: $f_{\text{SENSORMIN}} = 8 \text{ MHz}$
3	RESERVED	R/W	0	Reserved. Set to 0
2:0	RESP_TIME	R/W	b011	<b>Measurement Response Time Setting</b> Sets the Response Time, which is the number of sensor periods used per conversion. This setting applies to the R <sub>p</sub> and Standard Resolution L measurement, but not the High Resolution L measurement. This corresponds to the actual conversion time by: $\text{Conversion Time (s)} = \frac{\text{Response Time}}{3 \times f_{\text{SENSOR}}}$ b000: Reserved (do not use) b001: Reserved (do not use) b010: Response Time = 192 b011: Response Time = 384 ( <b>default value</b> ) b100: Response Time = 768 b101: Response Time = 1536 b110: Response Time = 3072 b111: Response Time = 6144

### 8.6.6 Register ALT\_CONFIG (address = 0x05) [reset = 0x00]

**Figure 18. Register ALT\_CONFIG**

7	6	5	4	3	2	1	0
RESERVED						SHUTDOWN_EN	LOPTIMAL
R/W						R/W	R/W

LEGEND: R/W = Read/Write; R = Read only; -n = value after reset

**Table 8. Register ALT\_CONFIG Field Descriptions**

Bit	Field	Type	Reset	Description
7:2	RESERVED	R/W	b00'0000	Reserved. Set to b00'0000.
1	SHUTDOWN_EN	R/W	0	<b>Shutdown Enable</b> Enables shutdown mode of operation. If SHUTDOWN_EN is not set to 1, then SHUTDOWN (Address 0x0B:[1]) does not have any effect. b0: Shutdown not enabled ( <b>default value</b> ). b1: Shutdown functionality enabled.
0	LOPTIMAL	R/W	0	<b>Optimize for L Measurements</b> Optimize sensor drive signal for L measurements (for both High-Res L and L measurement). When LOPTIMAL is enabled, R <sub>p</sub> measurements are not completed. It is also necessary to set DOK_REPORT=1 when this mode is enabled. b0: L optimal disabled; both RP+L/LHR measurements ( <b>default value</b> ). b1: Only perform LHR and/or L-only measurements. R <sub>p</sub> measurements are invalid.

### 8.6.7 Register RP\_THRESH\_HI\_LSB (address = 0x06) [reset = 0x00]

This register can be modified while the LDC1101 is in active mode.

**Figure 19. Register RP\_THRESH\_HI\_LSB**

7	6	5	4	3	2	1	0
RP_THRESH_HI_LSB							
R/W							

LEGEND: R/W = Read/Write; R = Read only; -n = value after reset

**Table 9. Register RP\_THRESH\_HI\_LSB Field Descriptions**

Bit	Field	Type	Reset	Description
7:0	RP_THRESH_HI_LSB	R/W	0x00	<b>R<sub>p</sub> High Threshold LSB Setting</b> Combine with value in Register RP_THRESH_HI_MSB (Address 0x07) to set the upper R <sub>p</sub> conversion threshold: $RP\_THRESH\_HI = RP\_THRESH\_HI[15:8] \times 256 + RP\_THRESH\_HI[7:0]$ If RP_DATA conversion result is greater than the RP_THRESH_HI, RP_TH_I is asserted.  Note that RP_THRESH_HI_LSB is buffered and does not change the device configuration until a write to RP_TRESH_HI_MSB is performed. Note that both registers 0x06 and 0x07 must be written to change the value of RP_THRESH_HI.  0x00: <b>default value</b>

### 8.6.8 Register RP\_THRESH\_HI\_MSB (address = 0x07) [reset = 0x00]

This register can be modified while the LDC1101 is in active mode.

**Figure 20. Register RP\_THRESH\_HI\_MSB**

7	6	5	4	3	2	1	0
RP_THRESH_HI_MSB							
R/W							

LEGEND: R/W = Read/Write; R = Read only; -n = value after reset

**Table 10. Register RP\_THRESH\_HI\_MSB Field Descriptions**

Bit	Field	Type	Reset	Description
7:0	RP_THRESH_HI_MSB	R/W	0x00	<b>R<sub>P</sub> High Threshold MSB Setting</b> Combine with value in Register RP_THRESH_HI_LSB (Address 0x06) to set the upper R <sub>P</sub> conversion threshold. 0x00: <b>default value</b>

### 8.6.9 Register RP\_THRESH\_LO\_LSB (address = 0x08) [reset = 0x00]

This register can be modified while the LDC1101 is in active mode.

**Figure 21. Register RP\_THRESH\_LO\_LSB**

7	6	5	4	3	2	1	0
RP_THRESH_LO_LSB							
R/W							

LEGEND: R/W = Read/Write; R = Read only; -n = value after reset

**Table 11. Register RP\_THRESH\_LO\_LSB Field Descriptions**

Bit	Field	Type	Reset	Description
7:0	RP_THRESH_LO[7:0]	R/W	0x00	<b>R<sub>P</sub> Low Threshold LSB Setting</b> Combine with value in Register RP_THRESH_LO_MSB (Address 0x09) to set the lower R <sub>P</sub> conversion threshold: $RP\_THRESH\_LO = RP\_THRESH\_LO[15:8] \times 256 + RP\_THRESH\_LO[7:0]$ If RP_DATA conversion result is less than the RP_THRESH_LO, RP_HI_LON is asserted. Note that RP_THRESH_LO_LSB is buffered and does not change the device configuration until a write to RP_THRESH_LO_MSB is performed. Note that both registers 0x08 and 0x09 must be written to change the value of RP_THRESH_LO. 0x00: <b>default value</b>

### 8.6.10 Register RP\_THRESH\_LO\_MSB (address = 0x09) [reset = 0x00]

This register can be modified while the LDC1101 is in active mode

**Figure 22. Register RP\_THRESH\_LO\_MSB**

7	6	5	4	3	2	1	0
RP_THRESH_LO_MSB							
R/W							

LEGEND: R/W = Read/Write; R = Read only; -n = value after reset

**Table 12. Register RP\_THRESH\_LO\_MSB Field Descriptions**

Bit	Field	Type	Reset	Description
7:0	RP_THRESH_LO_MSB[15:8]	R/W	0x00	<b>R<sub>P</sub> Low Threshold MSB Setting</b> Combine with value in Register RP_THRESH_LO_LSB (Address 0x08) to set the lower R <sub>P</sub> conversion threshold. 0x00: <b>default value</b>

### 8.6.11 Register INTB\_MODE (address = 0x0A) [reset = 0x00]

This register can be modified while the LDC1101 is in active mode.

**Figure 23. Register INTB\_MODE**

7	6	5	4	3	2	1	0	
INTB2SDO	RESERVED	INTB_FUNC						
R/W	R/W	R/W						

LEGEND: R/W = Read/Write; R = Read only; -n = value after reset

**Table 13. INTB\_MODE Field Descriptions**

Bit	Field	Type	Reset	Description
7	INTB2SDO	R/W	0	<b>INTB Output on SDO</b> Output INTB signal on SDO pin. b0: do not report INTB on SDO pin ( <b>default value</b> ) b1: report INTB on SDO pin
6	RESERVED	R/W	0	Reserved. Set to 0
5:0	INTB_FUNC	R/W	b00'0000	Select INTB signal reporting. INTB2SDO must be set to 1 for the selected signal to appear on the SDO pin. Refer to <a href="#">INTB Reporting on SDO</a> for configuration details. b10'0000: Report LHR Data Ready b01'0000: Compare L conversion to L Thresholds (hysteresis) b00'1000: Compare L conversion to L High Threshold (latching) b00'0100: Report RP+L Data Ready b00'0010: Compare R <sub>P</sub> conversion to R <sub>P</sub> Thresholds (hysteresis) b00'0001: Compare R <sub>P</sub> conversion to R <sub>P</sub> High Threshold (latching) b00'0000: no output ( <b>default value</b> ) All other values: Reserved

### 8.6.12 9.Register START\_CONFIG (address = 0x0B) [reset = 0x01]

This register can be modified while the LDC1101 is in active mode.

**Figure 24. Register START\_CONFIG**

7	6	5	4	3	2	1	0
RESERVED						FUNC_MODE	
R/W						R/W	

LEGEND: R/W = Read/Write; R = Read only; -n = value after reset

**Table 14. Register START\_CONFIG Field Descriptions**

Bit	Field	Type	Reset	Description
7:2	RESERVED	R/W	b00'0000	Reserved. Set to b00'0000
1:0	FUNC_MODE	R/W	b01	<b>Functional Mode</b> Configure functional mode of device. In active mode, the device performs conversions. When in Sleep mode, the LDC1101 is in a reduced power mode; the device should be configured in this mode. Shutdown mode is a minimal current mode in which the device configuration is not retained. Note that SHUTDOWN_EN must be set to 1 prior to setting FUNC_MODE to b10. b00: Active conversion mode b01: Sleep mode ( <b>default value</b> ) b10: Set device to shutdown mode b11: Reserved

**8.6.13 Register D\_CONFIG (address = 0x0C) [reset = 0x00]**
**Figure 25. Register D\_CONFIG**

7	6	5	4	3	2	1	0
RESERVED							DOK_REPORT
R/W							R/W

LEGEND: R/W = Read/Write; R = Read only; -n = value after reset

**Table 15. Register D\_CONFIG Field Descriptions**

Bit	Field	Type	Reset	Description
7:1	RESERVED	R/W	b000'0000	Reserved. Set to b000'0000.
0	DOK_REPORT	R/W	0	<b>Sensor Amplitude Control</b> Continue to convert even if sensor amplitude is not regulated. b0: Require amplitude regulation for conversion ( <b>default value</b> ) b1: LDC continues to convert even if sensor amplitude is unable to maintain regulation.

**8.6.14 Register L\_THRESH\_HI\_LSB (address = 0x16) [reset = 0x00]**

This register can be modified while the LDC1101 is in active mode.

**Figure 26. Register L\_THRESH\_HI\_LSB**

7	6	5	4	3	2	1	0
L_THRESH_HI[7:0]							
R/W							

LEGEND: R/W = Read/Write; R = Read only; -n = value after reset

**Table 16. Register L\_THRESH\_HI\_LSB Field Descriptions**

Bit	Field	Type	Reset	Description
7:0	L_THRESH_HI[7:0]	R/W	0x00	<b>L High Threshold LSB Setting</b> Combine with value in Register L_THRESH_HI_MSB (Address 0x17) to set the upper L conversion threshold: $L_{ThreshHI} = L\_THRESH\_HI[15:8] \times 256 + L\_THRESH\_HI[7:0]$ If L_DATA conversion result is greater than the L_THRESH_HI, L_HIN is asserted. Note that L_THRESH_HI_LSB is buffered and does not change the device configuration until a write to L_TRESH_HI_MSB. 0x00: <b>default value</b>

**8.6.15 Register L\_THRESH\_HI\_MSB (address = 0x17) [reset = 0x00]**

This register can be modified while the LDC1101 is in active mode.

**Figure 27. Register L\_THRESH\_HI\_MSB**

7	6	5	4	3	2	1	0
L_THRESH_HI[15:8]							
R/W							

LEGEND: R/W = Read/Write; R = Read only; -n = value after reset

**Table 17. Register L\_THRESH\_HI\_MSB Field Descriptions**

Bit	Field	Type	Reset	Description
7:0	L_THRESH_HI[15:8]	R/W	0x00	<b>L High Threshold MSB Setting</b> Combine with value in Register L_THRESH_HI_LSB (Address 0x16) to set the upper L conversion threshold. 0x00: <b>default value</b>

### 8.6.16 Register L\_THRESH\_LO\_LSB (address = 0x18) [reset = 0x00]

This register can be modified while the LDC1101 is in active mode.

**Figure 28. Register L\_THRESH\_LO\_LSB**

7	6	5	4	3	2	1	0
L_THRESH_L[7:0]							
R/W							

LEGEND: R/W = Read/Write; R = Read only; -n = value after reset

**Table 18. Register L\_THRESH\_LO\_LSB Field Descriptions**

Bit	Field	Type	Reset	Description
7:0	L_THRESH_LO[7:0]	R/W	0x00	<p><b>L Low Threshold LSB Setting</b></p> <p>Combine with value in Register L_THRESH_LO_MSB (Address 0x19) to set the lower L conversion threshold:</p> $L_{\text{ThreshLO}} = L\_THRESH\_LO[15:8] \times 256 + L\_THRESH\_LO[7:0]$ <p>If L_DATA conversion result is less than the L_THRESH_LO, L_HI_LON is asserted.</p> <p>Note that L_THRESH_LO_LSB is buffered and does not change the device configuration until a write to L_TRESH_LO_MSB.</p> <p>0x00: <b>default value</b></p>

### 8.6.17 Register L\_THRESH\_LO\_MSB (address = 0x19) [reset = 0x00]

This register can be modified while the LDC1101 is in active mode.

**Figure 29. L\_THRESH\_LO\_MSB**

7	6	5	4	3	2	1	0
L_THRESH_L[15:8]							
R/W							

LEGEND: R/W = Read/Write; R = Read only; -n = value after reset

**Table 19. L\_THRESH\_LO\_MSB Field Descriptions**

Bit	Field	Type	Reset	Description
7:0	L_THRESH_LO[15:8]	R/W	0x00	<p><b>L Low Threshold MSB Setting</b></p> <p>Combine with value in Register L_THRESH_LO_LSB (Address 0x18) to set the lower L conversion threshold.</p> <p>0x00: <b>default value</b></p>

**8.6.18 Register STATUS (address = 0x020 [reset = 0x00])**
**Figure 30. Register STATUS**

7	6	5	4	3	2	1	0
NO_SENSOR_OSC	DRDYB	RP_HIN	RP_HI_LON	L_HIN	L_HI_LON	RESERVED	POR_READ
R	R	R	R	R	R	R	R

LEGEND: R/W = Read/Write; R = Read only; -n = value after reset

**Table 20. Register STATUS Field Descriptions**

Bit	Field	Type	Reset	Description
7	NO_SENSOR_OSC	R	0	<b>Sensor Oscillation Not Present Error</b> Indicates that the sensor has stopped oscillating. This error may also be produced if the MIN_FREQ is set to too high a value. b0: Error condition has not occurred b1: LDC1101 has not detected the sensor oscillation.
6	DRDYB	R	0	<b>RP+L Data Ready</b> b0: New RP+L conversion data is available. b1: No new conversion data is available.
5	RP_HIN	R	0	<b>RP_DATA High Threshold Comparator</b> Note this field latches a low value. To clear, write 0x00 to register 0x0A. INTB_FUNC (register 0x0A:bits[5:0]) must be set to b00'0001 for this flag to be reported. b0: RP_DATA measurement has exceeded RP_THRESH_HI b1: RP_DATA measurement has not exceeded RP_THRESH_HI
4	RP_HI_LON	R	0	<b>RP_DATA Hysteresis Comparator</b> b0: RP_DATA measurement has gone above RP_THRESH_HI. b1: RP_DATA measurement has gone below RP_THRESH_LO.
3	L_HIN	R	0	<b>L_DATA High Threshold Comparator</b> Note this field latches a low value. To clear, write 0x00 to register 0x0A. INTB_FUNC (register 0x0A:bits[5:0]) must be set to b00'1000 for this flag to be reported. b0: L_DATA measurement has exceeded L_THRESH_HI b1: L_DATA measurement has not exceeded L_THRESH_HI
2	L_HI_LON	R	0	<b>L_DATA Hysteresis Comparator</b> b0: L_DATA measurement has gone above L_THRESH_HI. b1: L_DATA measurement has gone below L_THRESH_LO.
1	RESERVED	R	0	No Function 0: default value
0	POR_READ	R	0	<b>Device in Power-On-Reset</b> Indicates the device is in process of resetting. Note that the device cannot accept any configuration changes until reset is complete. Wait until POR_READ = 0 before changing any device configuration. b0: Device is not in reset. b1: Device is currently in reset; wait until POR_READ = 0.

### 8.6.19 Register RP\_DATA\_LSB (address = 0x21) [reset = 0x00]

NOTE: RP\_DATA\_LSB (Address 0x21) must be read prior to reading the RP\_DATA\_MSB (Address 0x22), L\_DATA\_MSB (Address 0x23), and L\_DATA\_LSB (Address 0x24) registers to properly retrieve conversion results.

**Figure 31. Register RP\_DATA\_LSB**

7	6	5	4	3	2	1	0
RP_DATA[7:0]							
R							

LEGEND: R/W = Read/Write; R = Read only; -n = value after reset

**Table 21. Register RP\_DATA\_LSB Field Descriptions**

Bit	Field	Type	Reset	Description
7:0	RP_DATA[7:0]	R	0x00	<b>RP-Measurement Conversion Result</b> Combine with values in Register RP_DATA_MSB (Address 0x22) to determine R <sub>p</sub> conversion result: $RP\_DATA = RP\_DATA[15:8] \times 256 + RP\_DATA[7:0]$

### 8.6.20 Register RP\_DATA\_MSB (address = 0x22) [reset = 0x00]

NOTE: RP\_DATA\_LSB (Address 0x21) must be read prior to reading this register to properly retrieve conversion results.

**Figure 32. Register RP\_DATA\_MSB**

7	6	5	4	3	2	1	0
RP_DATA[15:8]							
R							

LEGEND: R/W = Read/Write; R = Read only; -n = value after reset

**Table 22. Register RP\_DATA\_MSB Field Descriptions**

Bit	Field	Type	Reset	Description
7:0	RP_DATA[15:8]	R	0x00	<b>RP-Measurement Conversion Result</b> Combine with values in Register RP_DATA_LSB (Address 0x21) to determine R <sub>p</sub> conversion result:

### 8.6.21 Register L\_DATA\_LSB (address = 0x23) [reset = 0x00]

NOTE: RP\_DATA\_LSB (Address 0x21) must be read prior to reading this register to properly retrieve conversion results.

**Figure 33. Register L\_DATA\_LSB**

7	6	5	4	3	2	1	0
L_DATA[7:0]							
R							

LEGEND: R/W = Read/Write; R = Read only; -n = value after reset

**Table 23. Register L\_DATA\_LSB Field Descriptions**

Bit	Field	Type	Reset	Description
7:0	L_DATA[7:0]	R	0x00	<b>L-Measurement Conversion Result</b> Combine with values in Register L_DATA_MSB (Address 0x24) to determine L conversion result: $L\_DATA = L\_DATA[15:8] \times 256 + L\_DATA[7:0]$ $f_{SENSOR} = (f_{CLKIN} \times RESP\_TIME) / (3 \times L\_DATA)$

**8.6.22 Register L\_DATA\_MSB (address = 0x24) [reset = 0x00]**

NOTE: RP\_DATA\_LSB (Address 0x21) must be read prior to reading this register to properly retrieve conversion results.

**Figure 34. Register L\_DATA\_MSB**

7	6	5	4	3	2	1	0
L_DATA[15:8]							
R							

LEGEND: R/W = Read/Write; R = Read only; -n = value after reset

**Table 24. Register L\_DATA\_MSB Field Descriptions**

Bit	Field	Type	Reset	Description
7:0	L_DATA[15:8]	R	0x00	<b>L-Measurement Conversion Result</b> Combine with values in Register L_DATA_LSB (Address 0x23) to determine L conversion result.

**8.6.23 Register LHR\_RCOUNT\_LSB (address = 0x30) [reset = 0x00]**
**Figure 35. Register LHR\_RCOUNT\_LSB**

7	6	5	4	3	2	1	0
RCOUNT[7:0]							
R/W							

LEGEND: R/W = Read/Write; R = Read only; -n = value after reset

**Table 25. Register LHR\_RCOUNT\_LSB Field Descriptions**

Bit	Field	Type	Reset	Description
7:0	RCOUNT[7:0]	R/W	0x00	<b>High Resolution L-Measurement Reference Count Setting</b> Combine with value in Register LHR_RCOUNT_MSB (Address 0x31) to set the measurement time for High Resolution L Measurements. 0x00: <b>default value</b>

**8.6.24 Register LHR\_RCOUNT\_MSB (address = 0x31) [reset = 0x00]**
**Figure 36. Register LHR\_RCOUNT\_MSB**

7	6	5	4	3	2	1	0
RCOUNT[15:8]							
R/W							

LEGEND: R/W = Read/Write; R = Read only; -n = value after reset

**Table 26. Register LHR\_RCOUNT\_MSB Field Descriptions**

Bit	Field	Type	Reset	Description
7:0	RCOUNT[15:8]	R/W	0x00	<b>High Resolution L-Measurement Reference Count Setting</b> Combine with value in Register LHR_RCOUNT_LSB (Address 0x30) to set the measurement time for High Resolution L Measurements. Higher values for LHR_RCOUNT have a higher effective measurement resolution but a lower sample rate. Refer to <a href="#">LHR Sample Rate Configuration With RCOUNT</a> for more details. Measurement Time ( $t_{CONV}$ ) = $(RCOUNT[15:0] \times 16 + 55) / f_{CLKIN}$ $RCOUNT = RCOUNT[15:8] \times 256 + RCOUNT[7:0]$ Valid range: $2 \leq RCOUNT[15:0] \leq 65535$ 0x00: <b>default value</b>

**8.6.25 Register LHR\_OFFSET\_LSB (address = 0x32) [reset = 0x00]**
**Figure 37. Register LHR\_OFFSET\_LSB**

7	6	5	4	3	2	1	0
LHR_OFFSET[7:0]							
R/W							

LEGEND: R/W = Read/Write; R = Read only; -n = value after reset

**Table 27. Register LHR\_OFFSET\_LSB Field Descriptions**

Bit	Field	Type	Reset	Description
7:0	LHR_OFFSET[7:0]	R/W	0x00	<b>High Resolution L-Measurement Offset Setting</b> Combine with value in Register LHR_OFFSET_LSB (Address 0x32) to set the offset value applied to High Resolution L Measurements. 0x00: <b>default value</b>

**8.6.26 Register LHR\_OFFSET\_MSB (address = 0x33) [reset = 0x00]**
**Figure 38. Register LHR\_OFFSET\_MSB**

7	6	5	4	3	2	1	0
LHR_OFFSET[15:8]							
R/W							

LEGEND: R/W = Read/Write; R = Read only; -n = value after reset

**Table 28. Register LHR\_OFFSET\_MSB Field Descriptions**

Bit	Field	Type	Reset	Description
7:0	LHR_OFFSET[15:8]	R/W	0x00	<b>High Resolution L-Measurement Offset Setting</b> Combine with value in Register LHR_OFFSET_LSB (Address 0x32) to set the offset value applied to High Resolution L Measurements. 0x00: <b>default value</b>

**8.6.27 Register LHR\_CONFIG (address = 0x34) [reset = 0x00]**
**Figure 39. Register LHR\_CONFIG**

7	6	5	4	3	2	1	0
RESERVED						SENSOR_DIV	
R/W						R/W	

LEGEND: R/W = Read/Write; R = Read only; -n = value after reset

**Table 29. Register LHR\_CONFIG Field Descriptions**

Bit	Field	Type	Reset	Description
7:2	RESERVED	R/W	b00'0000	Reserved. Set to b00'0000
1:0	SENSOR_DIV	R/W	b00	Sensor Clock Divider Setting Divide the sensor frequency by programmed divider. This divider can be used to set the sensor frequency lower than the reference frequency. Refer to <a href="#">Sensor Input Divider</a> for more details. b00: Sensor Frequency not divided ( <b>default value</b> ) b01: Sensor Frequency divided by 2 b10: Sensor Frequency divided by 4 b11: Sensor Frequency divided by 8

**8.6.28 Register LHR\_DATA\_LSB (address = 0x38) [reset = 0x00]**

NOTE: The LHR\_DATA\_X registers must be read in the sequence LHR\_DATA\_LSB (Address 0x38) first, then LHR\_DATA\_MID (Address 0x39), and last LHR\_DATA\_MSB (Address 0x3A) to ensure correct data.

**Figure 40. Register LHR\_DATA\_LSB**

7	6	5	4	3	2	1	0
LHR_DATA[7:0]							
R							

LEGEND: R/W = Read/Write; R = Read only; -n = value after reset

**Table 30. Register LHR\_DATA\_LSB Field Descriptions**

Bit	Field	Type	Reset	Description
7:0	LHR_DATA[7:0]	R	0x00	<b>High Resolution L-Measurement Conversion Result</b> Combine with values in Registers LHR_DATA_MID (Address 0x39) and LHR_DATA_MSB (Address 0x3A) to determine conversion result. When LHR_OFFSET = 0x0000, $f_{\text{SENSOR}}$ can be determined by: $f_{\text{SENSOR}} = f_{\text{CLKIN}} \times 2^{\text{SENSOR\_DIV}} \times \text{LHR\_DATA} \div 2^{24}$

**8.6.29 Register LHR\_DATA\_MID (address = 0x39) [reset = 0x00]**

NOTE: The LHR\_DATA\_X registers must be read in the sequence LHR\_DATA\_LSB (Address 0x38) first, then LHR\_DATA\_MID (Address 0x39), and last LHR\_DATA\_MSB (Address 0x3A) to ensure correct data.

**Figure 41. Register LHR\_DATA\_MID**

7	6	5	4	3	2	1	0
LHR_DATA[15:8]							
R							

LEGEND: R/W = Read/Write; R = Read only; -n = value after reset

**Table 31. Register LHR\_DATA\_MID Field Descriptions**

Bit	Field	Type	Reset	Description
7:0	LHR_DATA[15:8]	R	0x00	<b>High Resolution L-Measurement Conversion Result</b> Combine with values in Registers LHR_DATA_LSB (Address 0x38) and LHR_DATA_MSB (Address 0x3A) to determine conversion result.

**8.6.30 Register LHR\_DATA\_MSB (address = 0x3A) [reset = 0x00]**

NOTE: The LHR\_DATA\_X registers must be read in the sequence LHR\_DATA\_LSB (Address 0x38) first, then LHR\_DATA\_MID (Address 0x39), and last LHR\_DATA\_MSB (Address 0x3A) to ensure correct data.

**Figure 42. Register LHR\_DATA\_MSB**

7	6	5	4	3	2	1	0
LHR_DATA[23:16]							
R							

LEGEND: R/W = Read/Write; R = Read only; -n = value after reset

**Table 32. Register LHR\_DATA\_MSB Field Descriptions**

Bit	Field	Type	Reset	Description
7:0	LHR_DATA[23:16]	R	0x00	<b>High Resolution L-Measurement Conversion Result</b> Combine with values in Registers LHR_DATA_LSB (Address 0x38) and LHR_DATA_MID (Address 0x39) to determine conversion result.

**8.6.31 Register LHR\_STATUS (address = 0x3B) [reset = 0x00]**
**Figure 43. Register LHR\_STATUS**

7	6	5	4	3	2	1	0
UNUSED			ERR_ZC	ERR_OR	ERR_UR	ERR_OF	LHR_DRDY
R			R	R	R	R	R

LEGEND: R/W = Read/Write; R = Read only; -n = value after reset

**Table 33. Register LHR\_STATUS Field Descriptions**

Bit	Field	Type	Reset	Description
7:5	UNUSED	R	0	No Function
4	ERR_ZC	R	0	<b>Zero Count Error</b> Zero count errors are applicable for LHR measurements and indicate that no cycles of the sensor occurred in the programmed measurement interval. This indicates either a sensor error or the sensor frequency is too low. This field is updated after register 0x38 has been read. <b>b0:</b> No Zero Count error has occurred for the last LHR conversion result read. <b>b1:</b> A Zero Count error has occurred.
3	ERR_OR	R	0	<b>Conversion Over-range Error</b> Conversion over-range errors are applicable for LHR measurements and indicate that the sensor frequency exceeded the reference frequency. This field is updated after register 0x38 has been read. <b>b0:</b> No Conversion Over-range error has occurred for the last LHR conversion result read. <b>b1:</b> A Conversion Over-range error has occurred.
2	ERR_UR	R	0	<b>Conversion Under-range Error</b> Conversion under-range errors are applicable for LHR measurements and indicate that the output code is negative; this occurs when programmed LHR offset register value is too large. This field is updated after register 0x38 has been read. <b>b0:</b> No Conversion Under-range error has occurred for the last LHR conversion result read. <b>b1:</b> A Conversion Under-range error has occurred.
1	ERR_OF	R	0	<b>Conversion Over-flow Error</b> Conversion over-flow errors are applicable for LHR measurements and indicate that the sensor frequency is too close to the reference frequency. This field is updated after register 0x38 has been read. <b>b0:</b> No Conversion Over-flow error has occurred for the last LHR conversion result read. <b>b1:</b> A Conversion Over-flow error has occurred.
0	LHR_DRDY	R	0	<b>LHR Data Ready</b> <b>b0:</b> Unread LHR conversion data is available. This field is set to 0 at the end of an LHR conversion and remains asserted until a read of register 0x38. <b>b1:</b> No unread LHR conversion data is available.

**8.6.32 Register RID (address = 0x3E) [reset = 0x02]**
**Figure 44. Register RID**

7	6	5	4	3	2	1	0
V_ID					RID		
R					R		

LEGEND: R/W = Read/Write; R = Read only; -n = value after reset

**Table 34. Register RID Field Descriptions**

Bit	Field	Type	Reset	Description
7:3	V_ID	R	b00'0000	<b>DEVICE ID</b> Returns fixed value indicating device ID. <b>b0'0000</b> : indicates LDC1101 (default value)
2:0	RID	R	b010	<b>RID</b> Returns device RID. <b>b010</b> : Default value

**8.6.33 Register DEVICE\_ID (address = 0x3F) [reset = 0xD4]**
**Figure 45. Register DEVICE\_ID**

7	6	5	4	3	2	1	0
CHIP_ID							
R							

LEGEND: R/W = Read/Write; R = Read only; -n = value after reset

**Table 35. Register DEVICE\_ID Field Descriptions**

Bit	Field	Type	Reset	Description
7:0	CHIP_ID	R	0xD4	<b>CHIP_ID</b> Returns fixed value indicating device Family ID. <b>0xD4</b> : indicates LDC1101 family (default value)

## 9 Application and Implementation

### NOTE

Information in the following applications sections is not part of the TI component specification, and TI does not warrant its accuracy or completeness. TI's customers are responsible for determining suitability of components for their purposes. Customers should validate and test their design implementation to confirm system functionality.

### 9.1 Application Information

#### 9.1.1 TI Designs and Application Notes

The following resources contain additional information on LDC1101 operation, configuration, and system design:

- [Inductive Linear Position Sensing Using the LDC1101](#)
- [Inductive Proximity Switch Using the LDC1101](#)
- [LDC Selection Guide Application Report](#)
- [LDC Sensor Design Application Report](#)
- [LDC Target Design Application Report](#)
- [Performing L Measurements from LDC DRDY Timing Application Report](#)
- [Optimizing L Measurement Resolution for the LDC161x and LDC1101 Application Report](#)
- [Measuring  \$R\_P\$  of an L-C Sensor for Inductive Sensing Application Report](#)
- [Setting LDC1312/4, LDC1612/4, and LDC1101 Sensor Drive Configuration Application Report](#)

#### 9.1.2 Theory of Operation

An AC current flowing through an inductor generates an AC magnetic field. If a conductive material, such as a metal object, is brought into the vicinity of the inductor, the magnetic field induces a circulating current (eddy current) on the surface of the conductor. The eddy current is a function of the distance, size, and composition of the conductor.

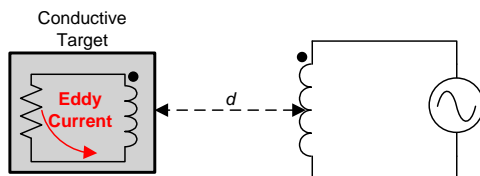

Figure 46. Conductor in an AC Magnetic Field

The eddy current generates its own magnetic field, which opposes the original field generated by the inductor. This effect can be considered as a set of coupled inductors, where the inductor is the primary winding and the eddy current in the conductor represents the secondary winding. The coupling between the windings is a function of the inductor, and the resistivity, distance, size, and shape of the conductor.

To minimize the current required to drive the inductor, a parallel capacitor is added to create a resonant circuit, which oscillates at a frequency given by Equation 1 when energy is injected into the circuit. In this way, the LDC1101 only needs to compensate for the parasitic losses in the sensor, represented by the series resistance  $R_S$  of the LC tank. The oscillator is then restricted to operating at the resonant frequency of the LC circuit and injects sufficient energy to compensate for the loss from  $R_S$ .

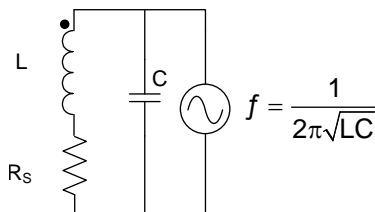
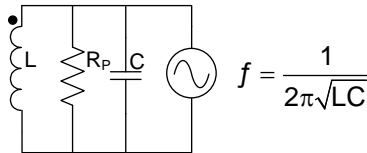

Figure 47. LC Tank

### Application Information (continued)

The resistance and inductance of the secondary winding caused by the eddy current can be modeled as a distant dependent resistive and inductive component on the primary side (coil). We can then represent the circuit as an equivalent parallel circuit, as shown in [Figure 48](#).



**Figure 48. Equivalent Parallel Circuit**

The value of  $R_P$  can be calculated with:

$$R_P = \frac{L}{R_S C}$$

where

- $R_S$  is the AC series resistance at the frequency of operation.
- $C$  is the parallel capacitance
- $L$  is the inductance

(2)

$R_P$  can be viewed as the load on the sensor driver; this load corresponds to the current drive needed to maintain the oscillation amplitude. The position of a target can change  $R_P$  by a significant amount, as shown in [Figure 49](#). The value of  $R_P$  can then be used to determine the position of a conductive target. If the value of  $R_P$  is too low, the sensor driver is not be able to maintain sufficient oscillation amplitude.

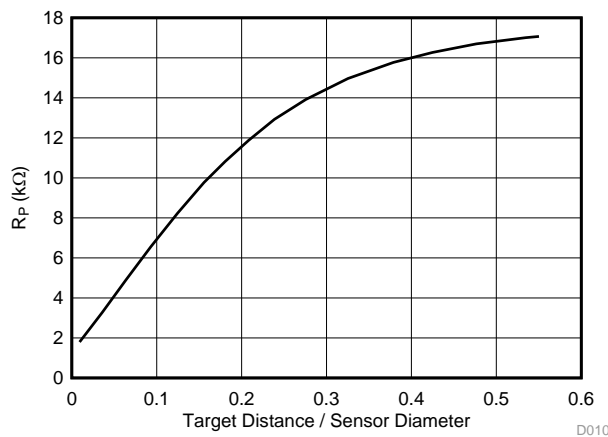

**Figure 49.  $R_P$  vs Target Distance for a 14-mm Diameter Sensor**

#### 9.1.3 $R_P+L$ Mode Calculations

For many systems which use the LDC1101, the actual sensor  $R_P$ , sensor frequency, or sensor inductance is not necessary to determine the target position; typically the equation of interest is:

$$\text{Position}_{\text{Target}} = f(R_P\text{-DATA}) \text{ or } \text{Position}_{\text{Target}} = f(L\text{-DATA})$$

where

- $R_P\text{-DATA}$  is the contents of registers 0x21 and 0x22
- $L\text{-DATA}$  is the contents of registers 0x23 and 0x24

(3)

These position equations are typically system dependent. For applications where the Sensor  $R_P$  in  $\Omega$ s needs to be calculated, use [Equation 4](#):

Application Information (continued)

$$R_p = \frac{R_{P\_MAX} \times R_{P\_MIN}}{R_{P\_MAX} \left(1 - \frac{RPDATA}{2^{16} - 1}\right) + R_{P\_MIN} \frac{RPDATA}{2^{16} - 1}}$$

where

- RPDATA is the contents of RP\_DATA\_MSB and RP\_DATA\_LSB (registers 0x21 and 0x22),
- RP\_MIN is the value set by RP\_MIN in register RP\_SET (register 0x01), and
- RP\_MAX is the value set by RP\_MAX in register RP\_SET (register 0x01).

For example, with device settings of:

- RP\_MIN set to 1.5 kΩ, and
- RP\_MAX set to 12 kΩ.

If RPDATA = 0x33F1 (register 0x21 = 0xF1 and register 0x22 = 0x33), which is 13297 decimal, then the sensor R<sub>p</sub> = 1.824 kΩ.

If HIGH\_Q\_SENSOR (Register 0x01-b[7]) is set, then the equation is simply:

$$R_p = \frac{R_{P\_MIN}}{\left(1 - \frac{RPDATA}{2^{16} - 1}\right)}$$

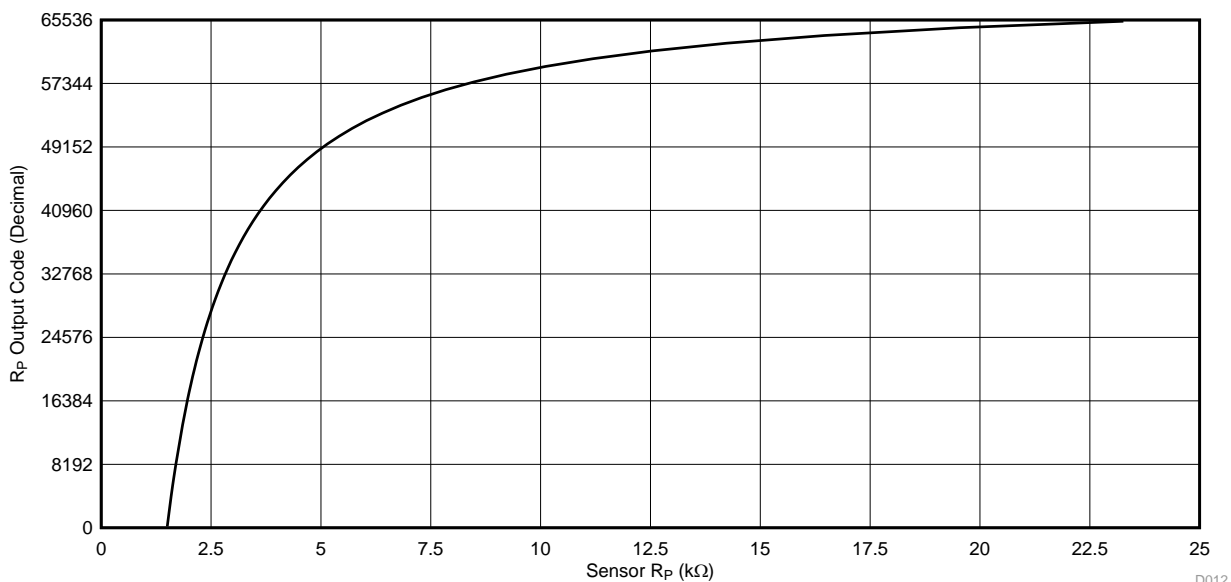

Figure 50. LDC1101 R<sub>p</sub> Transfer Curve with RPMIN = 1.5 kΩ and RP\_MAX = 24 kΩ

The sensor frequency in Hz can be calculated from Equation 6:

$$f_{SENSOR} = \frac{f_{CLKIN} \times RESP\_TIME}{3 \times L\_DATA}$$

where

- f<sub>CLKIN</sub> is the frequency input to the CLKIN pin,
- L\_DATA is the contents of registers 0x23 and 0x24, and
- RESP\_TIME is the programmed response time in register 0x04.

The inductance in Henrys can then be determined from Equation 7:

$$L_{SENSOR} = \frac{1}{C_{SENSOR} \times (2\pi f_{SENSOR})^2}$$

**Application Information (continued)**

where

- $C_{\text{SENSOR}}$  is the fixed sensor capacitance in Farads, and
- $f_{\text{SENSOR}}$  is the measured sensor frequency, as calculated in Equation 6 above. (7)

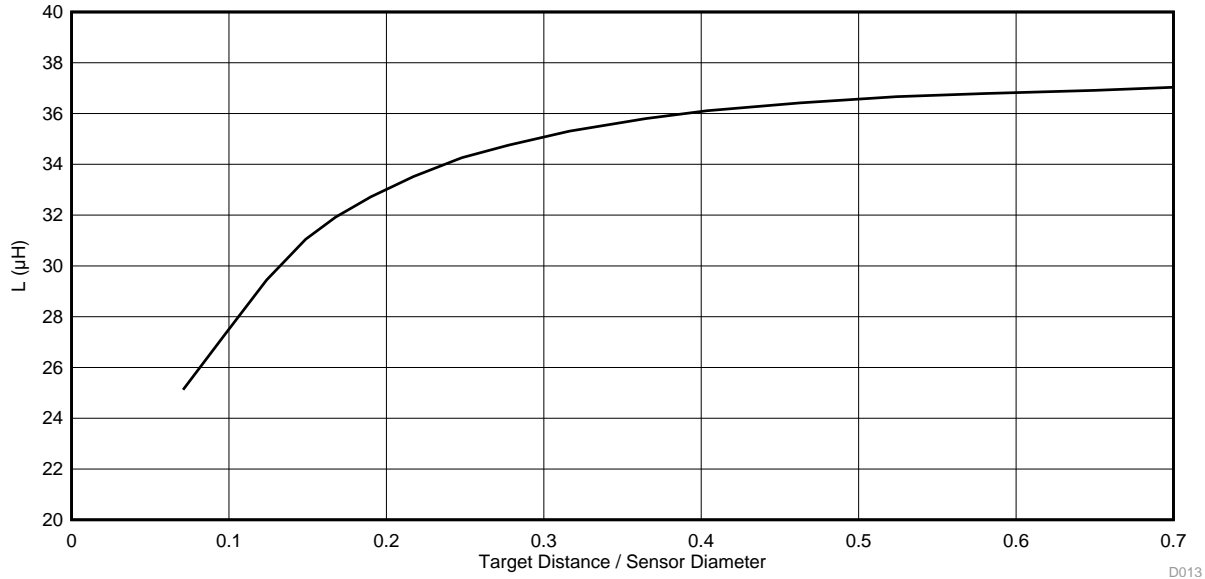
**Figure 51. Inductance vs Normalized Target Distance for an Example Sensor**
**9.1.4 LDC1101 R<sub>p</sub> Configuration**

Setting the RP\_MIN and RP\_MAX parameters is necessary for proper operation of the LDC1101; the LDC1101 may not be able to effectively drive the sensor with incorrect settings, as the sensor amplitude will be out of the valid operation region. The LDC1101EVM GUI and the LDC Excel<sup>®</sup> tools spreadsheet (<http://www.ti.com/lit/zip/slyc137>) can be used to calculate these parameters in an efficient manner.

For R<sub>p</sub> measurements, the following register settings must be set as follows:

- ALT\_CONFIG.LOPTIMAL(register 0x05-bit0) = 0
  - D\_CONFIG.DOK\_REPORT (register 0x0C-bit0) = 0
1. Ensure that the sensor characteristics are within the Sensor boundary conditions:
    - (a)  $500 \text{ kHz} < f_{\text{SENSOR}} < 10 \text{ MHz}$
    - (b)  $100 \text{ pF} < C_{\text{SENSOR}} < 10 \text{ nF}$
    - (c)  $1 \text{ μH} < L_{\text{SENSOR}} < 500 \text{ μH}$
  2. Measure the sensor's resonance impedance with minimal target interaction ( $R_{\text{PD}\infty}$ ). The minimal target interaction occurs when the target is farthest away from the sensor for axial sensing solutions or when the target coverage of the sensor is at a minimum for rotational or lateral sensing. Select the appropriate setting for R<sub>P</sub>MAX (register 0x01-bits [5:4]):
 
$$R_{\text{PD}\infty} \leq \text{RPMAX} \leq 2R_{\text{PD}\infty}$$
  3. Measure the sensor's resonance impedance with the target closest to the sensor ( $R_{\text{PD}0}$ ) as required by the application. Select the largest R<sub>P</sub>MIN setting that satisfies:
    - (a)  $\text{RPMIN} < 0.8 \times R_{\text{PD}0}$
    - (b) If the required R<sub>P</sub>MIN is smaller than  $750 \text{ Ω}$ ,  $R_{\text{PD}0}$  must be increased to be compliant with this boundary condition. This can be done by one or more of the following:
      - (a) increasing  $f_{\text{SENSOR}}$
      - (b) increasing the minimum distance between the target and the sensor
      - (c) reducing the  $R_s$  of the sensor by use of a thicker trace or wire
  4. Check if the worst-case Sensor quality factor  $Q_{\text{MIN}} = \text{RPMIN} \times \sqrt{C_{\text{SENSOR}}/L_{\text{SENSOR}}}$  is within the device operating range:

## Application Information (continued)

- (a)  $10 \leq Q_{\text{MIN}} \leq 400$
- (b) If  $Q_{\text{MIN}} < 10$ , for a fixed  $f_{\text{SENSOR}}$ , increase  $C_{\text{SENSOR}}$  and decrease  $L_{\text{SENSOR}}$ .
- (c) If  $Q_{\text{MIN}} > 400$ , for a fixed  $f_{\text{SENSOR}}$ , decrease  $C_{\text{SENSOR}}$  and increase  $L_{\text{SENSOR}}$ .
- (d) Alternatively the user may choose to not change the current Sensor parameters, but to increase  $R_{\text{p\_D0}}$ .

If the  $R_{\text{p}}$  of the sensor is greater than 75 k $\Omega$ ,  $R_{\text{p}}$  measurement accuracy may be improved by setting HIGH\_Q\_SENSOR to 1.

### 9.1.5 Setting Internal Time Constant 1

$R_{\text{p}}$  Measurements require configuration of the TC1 and TC2 registers. There are several programmable capacitance and resistance values. Set Time Constant 1 based on minimum sensor frequency:

$$R_1 \times C_1 = \frac{\sqrt{2}}{\pi V_{\text{AMP}} f_{\text{SENSOR-MIN}}}$$

where

- $f_{\text{SENSOR-MIN}}$  is the minimum sensor frequency encountered in the system; typically this occurs with no target present.
  - $V_{\text{AMP}}$  is sensor amplitude of 0.6V,
  - $R_1$  is the programmed setting for TC1.R1 (register 0x03-bits[4:0]), and
  - $C_1$  is the programmed setting for TC1.C1 (register 0x03-bits[7:6])
- (8)

The acceptable range of  $R_1$  is from 20.6 k $\Omega$  to 417.4 k $\Omega$ . If several combinations of  $R_1$  and  $C_1$  are possible, TI recommends using the largest capacitance setting for  $C_1$  that fits the constraints of Equation 8, as this will provide improved noise performance.

### 9.1.6 Setting Internal Time Constant 2

Set the Time Constant 2 (register 0x03) using Equation 9:

$$R_2 \times C_2 = 2 \times R_{\text{P\_MIN}} \times C_{\text{SENSOR}}$$

where

- $C_{\text{SENSOR}}$  is the parallel capacitance of the sensor.
  - $R_{\text{P\_MIN}}$  is the LDC1101 setting determined in [LDC1101  \$R\_{\text{p}}\$  Configuration](#) (for example, use 1.5 k $\Omega$  when  $R_{\text{P\_SET.RP\_MIN}} = \text{b110}$ ),
  - $R_2$  is the programmed setting for TC2.R2 (register 0x03-bits[5:0]), and
  - $C_2$  is the programmed setting for TC2.C2 (register 0x03-bits[7:6]).
- (9)

The acceptable range of  $R_2$  is from 24.60 k $\Omega$  to 834.8 k $\Omega$ . If several combinations of  $R_2$  and  $C_2$  are possible, TI recommends programming the larger capacitance setting for  $C_2$  that fits the constraints of Equation 9, as this will provide improved noise performance.

### 9.1.7 MIN\_FREQ and Watchdog Configuration

The LDC1101 includes a watchdog timer which monitors the sensor oscillation. While in active mode, if no sensor oscillation is detected, the LDC1101 sets STATUS.NO\_SENSOR\_OSC (register 0x20:bit7), and attempt to restart the oscillator. This restart resets any active conversion.

The watchdog waits an interval of time based on the setting of DIG\_CONF.MIN\_FREQ (register 0x04:bits[7:4]). The MIN\_FREQ setting is also used to configure the start-up of oscillation on the sensor. Select the DIG\_CONF.MIN\_FREQ (register 0x04:bits[7:4]) setting closest to the minimum sensor frequency; this setting is used for internal watchdog timing. If the watchdog determines the sensor has stopped oscillating, it reports the sensor has stopped oscillating in STATUS.NO\_SENSOR\_OSC (register 0x20-bit7). If the DIG\_CONF.MIN\_FREQ is set too low, then the LDC1101 takes a longer time interval to report that the sensor oscillation has stopped.

If the DIG\_CONF.MIN\_FREQ is set too high, then the watchdog may incorrectly report that the sensor has stopped oscillating and attempt to restart the sensor oscillation.

## Application Information (continued)

When the watchdog determines that the sensor has stopped oscillating, the LHR conversion results will contain 0xFFFFFFFF.

### 9.1.8 RP+L Sample Rate Configuration With RESP\_TIME

The RP+L sample rate can be adjusted by setting by DIG\_CONF.RESP\_TIME (register 0x04:bits[2:0]). The Response time can be configured from 192 to 6144 cycles of the sensor frequency. Higher values of Response time have a slower sample rate, but produce a higher resolution conversion.

$$\text{Conversion Time (s)} = \frac{\text{Response Time}}{3 \times f_{\text{SENSOR}}} \quad (10)$$

For applications which require only R<sub>P</sub> measurements, it is not necessary to apply a reference frequency on the CLKIN pin. If there is to be no signal input on CLKIN, it is recommended to tie CLKIN to ground in this situation. The L and LHR measurements will return 0.

### 9.1.9 High Resolution Inductance Calculation (LHR mode)

For many systems which use the LDC1101, the actual sensor frequency or sensor inductance is not necessary to determine the target position. Should the sensor frequency in Hz need to be determined, use [Equation 11](#):

$$f_{\text{SENSOR}} = \frac{2^{\text{SENSOR\_DIV}} \times f_{\text{CLKIN}} (\text{LHRDATA} + \text{LHROFFSET} \times 2^8)}{2^{24}} \quad (11)$$

where

- LHRDATA is the contents of registers 0x38, 0x39, and 0x3A,
- LHROFFSET is the programmed contents of registers 0x32 and 0x33,
- SENSOR\_DIV is the contents of LHR\_CONFIG.SENSOR\_DIV (register 0x34-bit[1:0]), and
- $f_{\text{CLKIN}}$  is the frequency input to the CLKIN pin: ensure that it is within the specified limits of 1 MHz to 16 MHz.

Note that LHR\_DATA=0x0000000 indicates a fault condition or that the LDC1101 has never completed an LHR conversion.

The inductance in Henrys can then be determined from the sensor frequency with [Equation 12](#):

$$L_{\text{SENSOR}} = \frac{1}{C_{\text{SENSOR}} \times (2\pi f_{\text{SENSOR}})^2} \quad (12)$$

where

- $C_{\text{SENSOR}}$  is the fixed sensor capacitance, and
- $f_{\text{SENSOR}}$  is the measured sensor frequency, as calculated above.

Example with the device set to:

- LHR\_OFFSET = 0x00FF (register 0x32 = 0xFF, and 0x33 = 0x00)
- $f_{\text{CLKIN}} = 16 \text{ MHz}$
- SENSOR\_DIV = b'01 (divide by 2)

and the conversion result is:

LHR\_DATA = 0x123456 (register 0x38 = 0x56, register 0x39 = 0x34, register 0x3A = 0x12)

Then entering LHR\_DATA = 0x123456 = 1193046 (decimal) into [Equation 11](#):

$$f_{\text{SENSOR}} = \frac{2^1 \times 16 \text{ MHz} (1193046 + 255 \times 2^8)}{2^{24}} \quad (13)$$

Results in  $f_{\text{SENSOR}} = 2.400066 \text{ MHz}$ .

## Application Information (continued)

### 9.1.10 LHR Sample Rate Configuration With RCOUNT

The conversion time represents the number of reference clock cycles used to measure the sensor frequency. The LHR mode conversion time is set by the Reference count in LHR\_RCOUNT.RCOUNT (registers 0x30 and 0x31). The LHR conversion time is:

$$t_{\text{CONV}} = \frac{(55 + \text{RCOUNT} \times 16)}{f_{\text{CLKIN}}} \quad (14)$$

The 55 is due to post-conversion processing and is a fixed value. The reference count value must be chosen to support the required number of effective bits (ENOB). For example, if an ENOB of 13 bits is required, then a minimum conversion time of  $2^{13} = 8192$  clock cycles is required. 8192 clock cycles correspond to a RCOUNT value of 0x0200.

Higher values for RCOUNT produce higher resolution conversions; the maximum setting, 0xFFFF, is required for full resolution.

### 9.1.11 Setting RPMIN for LHR Measurements

Configure the  $R_p$  measurement as shown previously for L measurements. If only L measurements are necessary, then the  $R_p$  measurement can be disabled by setting:

- ALT\_CONFIG.LOPTIMAL(register 0x05-bit0) = 1
- D\_CONFIG.DOK\_REPORT (register 0x0C-bit0) = 1

Setting these bits disable the sensor modulation used by the LDC1101 to measure  $R_p$  and can reduce L measurement noise. When the  $R_p$  modulation is disabled, the LDC1101 drives a fixed current level into the sensor. The current drive is configured by RP\_SET.RPMIN (address 0x01:bits[2:0]). The sensor amplitude must remain between 0.25 Vpk and 1.25 Vpk for accurate L measurements. Use [Table 36](#) to determine the appropriate RPMIN setting, based on the variation in sensor  $R_p$ . If multiple RPMIN values cover the Sensor  $R_p$ , use the higher current drive setting. The equation to determine sensor amplitude is:

$$R_p = \frac{\pi \times V_{\text{amp}}}{4 \times I_{\text{DRIVE}}} \quad (15)$$

**Table 36. LHR RPMIN Settings when Sensor  $R_p$  Modulation is Disabled**

RPMIN SETTING	RPMIN FIELD VALUE	SENSOR DRIVE ( $\mu\text{A}$ )	MINIMUM SENSOR $R_p$ ( $\text{k}\Omega$ )	MAXIMUM SENSOR $R_p$ ( $\text{k}\Omega$ )
0.75 $\text{k}\Omega$	b111	600	0.53	1.65
1.5 $\text{k}\Omega$	b110	300	1.1	3.3
3 $\text{k}\Omega$	b101	150	2.1	6.5
6 $\text{k}\Omega$	b100	75	4.2	13.1
12 $\text{k}\Omega$	b011	37.5	8.4	26.2
24 $\text{k}\Omega$	b010	18.7	16.9	52.4
48 $\text{k}\Omega$	b001	9.4	33.9	105
96 $\text{k}\Omega$	b000	4.7	67.9	209

For example, with a sensor that has an  $R_p$  which can vary between 2.7  $\text{k}\Omega$  to 5  $\text{k}\Omega$ , the appropriate setting for RPMIN would be 3  $\text{k}\Omega$  (RP\_SET.RPMIN = b101). For more information on sensor  $R_p$  and sensor drive, refer to *Configuring Inductive-to-Digital-Converters for Parallel Resistance ( $R_p$ ) Variation in L-C Tank Sensors(SNAA221)*.

### 9.1.12 Sensor Input Divider

The reference clock frequency should be greater than 4 times the sensor frequency for optimum measurement resolution:

$$f_{\text{CLKIN}} > 4f_{\text{SENSOR-MAX}}$$

For higher sensor frequencies, this relationship may not be realizable without the sensor divider. Set the sensor divider to an appropriate value to produce an effective reduction in the sensor frequency:

$$f_{\text{CLKIN}} > 4f_{\text{SENSOR-MAX}} \div \text{SENSOR\_DIV}$$

### 9.1.13 Reference Clock Input

Use a clean, low jitter, 40-60% duty cycle clock input with an amplitude swing within the range of  $V_{\text{DD}}$  and GND; proper clock impedance control, and series or parallel termination is recommended. The rise and fall time should be less than 5 ns. Do not use a spread-spectrum or modulated clock.

For optimum L measurement performance, it is recommended to use the highest reference frequency (16 MHz). LHR conversions do not start until a clock is provided on CLKIN.

### 9.1.14 INTB Reporting on SDO

INTB is a signal generated by the LDC1101 that reports a change in device status. When INTB\_MODE.INTB2SDO=1 (register 0x0A:bit7), INTB is multiplexed onto the SDO pin. Once the reporting is enabled, select the desired signal to report by setting INTB\_MODE.INTB\_FUNC (register 0x0A:bit[5:0]).

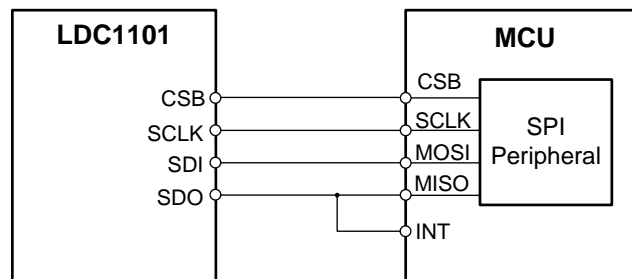

**Figure 52. SDO/INTB Connection to MCU**

For many microcontrollers, the MISO signal on the SPI peripheral cannot provide the desired interrupt functionality. One method to use the INTB functionality is to connect a second GPIO which triggers on a falling edge, as shown in [Figure 51](#). [Table 37](#) describes the signal functionality that can be programmed onto INTB.

**Table 37. INTB Signal Options**

SIGNAL	INTB_FUNC (0x0A:bit[5:0])	FUNCTIONALITY	SWITCH OUTPUT TYPE
LHR Data Ready (LHR-DRDY)	b10'0000	Indicates new High-Resolution Inductance (LHR) conversion data is available.	Latching
L_HI_LO	b01'0000	L Comparator with hysteresis	Hysteresis
L_TH_HI	b00'1000	Latching L High threshold compare	Latching
RP+L Data Ready (RPL-DRDY)	b00'0100	Indicates new RP+L conversion data is available.	Pulse
RP_HI_LO	b00'0010	R <sub>P</sub> Comparator with hysteresis	Hysteresis
RP_TH_HI	b00'0001	Latching R <sub>P</sub> High threshold compare	Latching
None	b00'0000	No INTB reporting – SDO pin only provides SDO functionality.	N/A

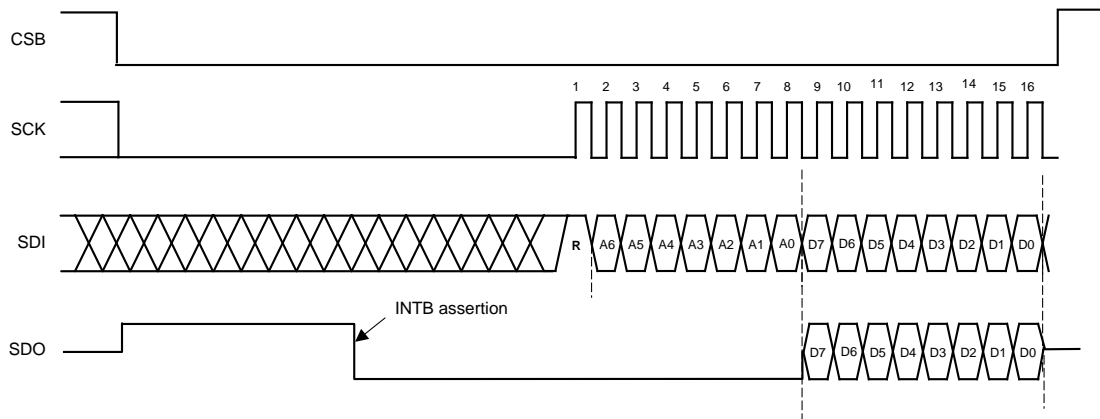

Figure 53. Example INTB Signal on SDO

When INTB\_MODE.INTB2SDO (register 0x0A:bit7) = 0, the SDO pin is in a Hi-Z state until the 8<sup>th</sup> falling edge of SCLK after CSB goes low. When INTB reporting is enabled by setting INTB\_MODE.INTB2SDO = 1, after CSB goes low, the SDO pin goes high and remains high until:

- the event configured by INTB\_MODE.INTB\_FUNC occurs,
- an SPI read transaction is initiated, or
- CSB is deasserted (pulled high)

9.1.15 DRDY (Data Ready) Reporting on SDO

Completion of a conversion can be indicated on the SDO pin by reporting the DRDY signal – there is a conversion complete indicator for the RP+L conversion (RPL-DRDY), and a corresponding conversion complete indicator for the LHR mode (LHR-DRDY).

When LHR-DRDY or RPL-DRDY is reported on SDO, the SDO pin is asserted on completion of a conversion. While in this mode, conversion data can be corrupted if a new conversion completes while reading the output data registers. To avoid data corruption, it is important to retrieve the conversion rates via SPI quicker than the shortest conversion interval, and to ensure that the data is retrieved before a new conversion could possibly complete.

When INTB is reporting RPL-DRDY, if CSB is held low for longer than one conversion cycle, INTB is deasserted approximately 100 ns to 2 μs prior to the completion of each conversion. The deassertion time is proportional to  $1/f_{SENSOR}$ .

When INTB is reporting LHR-DRDY, if CSB is held low for longer than one conversion cycle, INTB asserts on completion of the first conversion and remain low – and it remains asserted until cleared. To clear the LHR\_DRDY signal, read the LHR\_DATA registers.

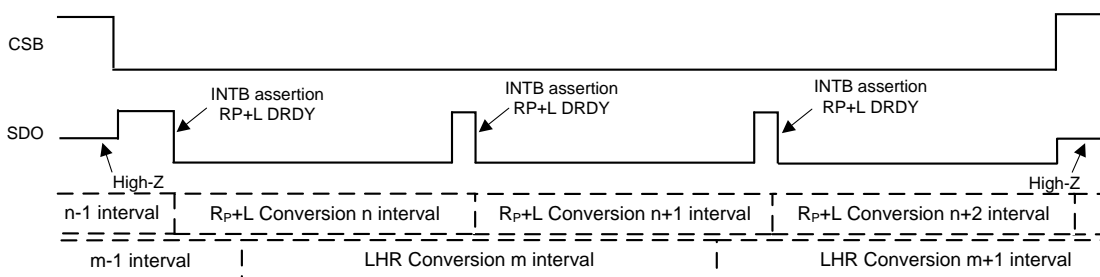
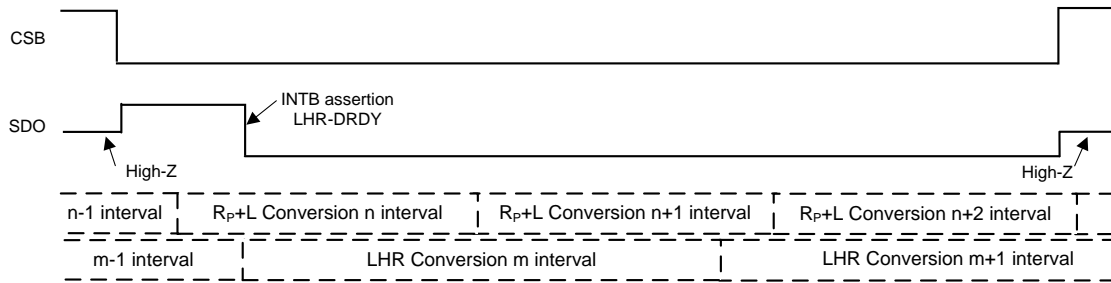

Figure 54. Reporting RPL-DRDY on INTB/SDO



**Figure 55. Reporting LHR-DRDY on INTB/SDO**

Note that the conversion interval for an LHR measurement is asynchronous to the conversion interval for an  $R_p+L$  measurement, therefore the LHR-DRDY signal cannot be used to determine when to read  $R_p+L$  conversion results, and vice versa.

**9.1.16 Comparator Functionality**

The LDC1101 provides comparator functionality, in which the  $R_p+L$  conversion results can be compared against two thresholds. The results of each  $R_p$  and  $L$  conversion can be compared against programmable thresholds and reported in the STATUS register. Note that the LHR conversion results cannot be used for comparator functionality.

In addition, the INTB signal can be asserted or deasserted when the conversion results increase above a Threshold High or decreases below a Threshold Low registers. In this mode, the LDC1101 essentially behaves as a proximity switch with programmable hysteresis. The threshold HI settings must be programmed to a higher value than the threshold LO registers (for example, if  $RP\_THRESH\_LO$  is set to 0x2000,  $RP\_THRESH\_HI$  must be programmed to 0x2001 or higher).

Either Latching and non-latching functions can be reported on INTB/SDO. The INTB signal can report a latching signal or a continuous comparison for each conversion result.

The Threshold setting registers (address 0x06:0x09 and 0x16:0x19) can be changed while the LDC1101 is in active conversion mode. It is recommended to change the register values using an extended SPI transaction as described in *SPI Programming*, so that the register updates can be completed in a shorter time interval. This functionality enables the LDC1101 to operate as a dynamic tracking switch. LDC1101 output codes can be readout in < 4  $\mu$ s, and the set of active thresholds can be updated in <6  $\mu$ s. It is not recommended to update the threshold registers more often than once per conversion interval of the LDC1101 (that is, do not change the threshold register values multiple times in a single conversion interval).

To clear a latched INTB signal, set  $INTB\_MODE = 0x80$ ; it is not necessary for the LDC1101 to be in Sleep mode to clear the latched output; the  $INTB\_MODE$  can be changed while the LDC1101 is in active mode. After clearing the latched output, re-enabling the  $INTB\_FUNC$  can be done while in active mode.

**Table 38. Comparator Options**

FUNCTION	THRESHOLD HIGH	THRESHOLD LOW	STATUS REPORTING	INTB/SDO REPORTING
$R_p$ Comparator with hysteresis	$RP\_THRESH\_HI$ (registers 0x06 and 0x07)	$RP\_THRESH\_LO$ (registers 0x08 and 0x09)	$RP\_HI\_LON$ (bit 4)	$RP\_HI\_LO$ ( $INTB\_MODE:INTB\_FUNC=b00'0010$ )
$R_p$ High threshold only (Latching)	$RP\_THRESH\_HI$ (registers 0x06 and 0x07)	N/A	$RP\_HIN$ (bit 5)	$RP\_TH\_HI$ ( $INTB\_MODE:INTB\_FUNC=b00'0001$ ) Note that INTB/SDO will latch.
$L$ Comparator with hysteresis	$L\_THRESH\_HI$ (registers 0x16 and 0x17)	$L\_THRESH\_LO$ (registers 0x18 and 0x19)	$L\_HI\_LON$ (bit 2)	$L\_HI\_LO$ ( $INTB\_MODE:INTB\_FUNC=b01'0000$ )
$L$ High threshold compare only (Latching)	$L\_THRESH\_HI$ (registers 0x18 and 0x19)	N/A	$L\_HIN$ (bit 3)	$L\_TH\_HI$ ( $INTB\_MODE:INTB\_FUNC=b00'1000$ ) Note that INTB/SDO will latch.

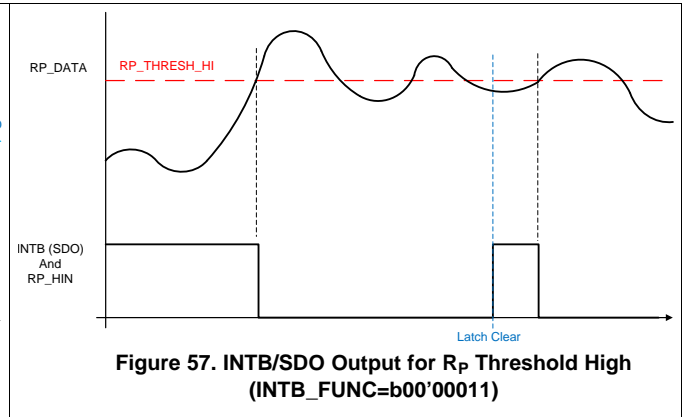
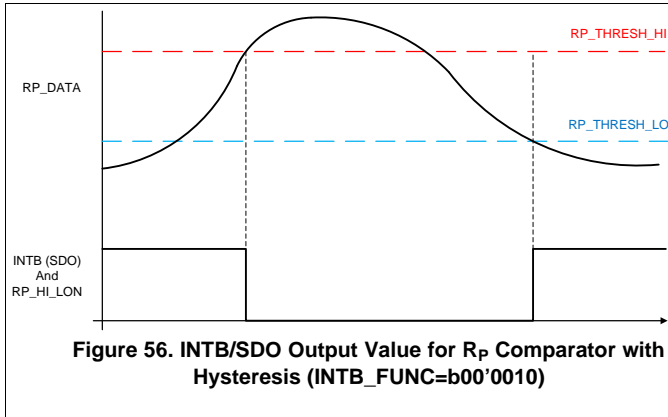

## 9.2 Typical Application

Implementation of a system using the LDC1101 first requires determining the appropriate measurement to perform. Refer to [http://e2e.ti.com/blogs\\_/b/analogwire/archive/2015/02/11/inductive-sensing-should-i-measure-l-rp-or-both](http://e2e.ti.com/blogs_/b/analogwire/archive/2015/02/11/inductive-sensing-should-i-measure-l-rp-or-both) for guidance.

For systems that require measurement of  $R_p$ , set the following:

- Configure  $R_p$  settings as instructed in [LDC1101  \$R\_p\$  Configuration](#).
- Set the internal time constants as detailed in [Setting Internal Time Constant 1](#) and [Setting Internal Time Constant 2](#).

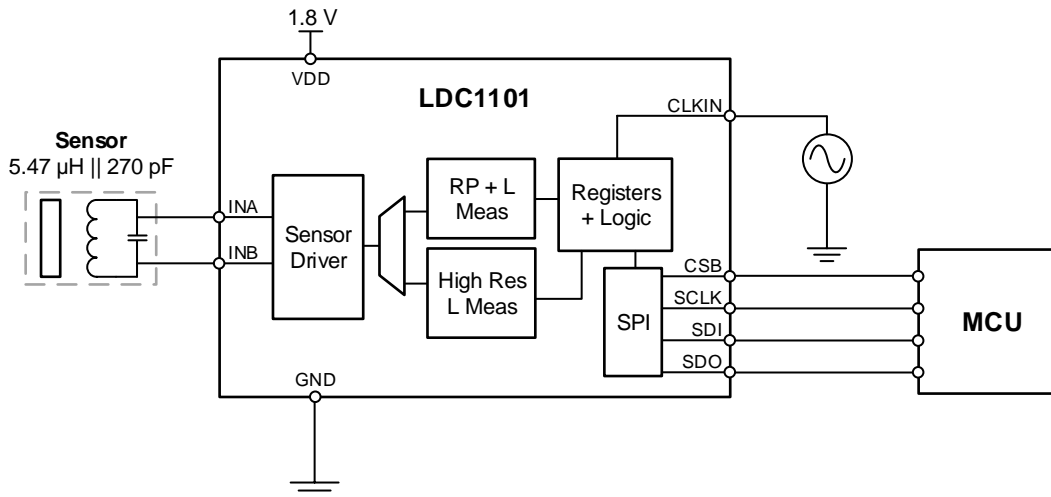

**Figure 58. Example LDC1101 Typical Application**

### 9.2.1 Design Requirements

Example of an axial measurement implementation using the LDC1101. In this example, the sensor is an inductor constructed of a multi-layer PCB coil in parallel with a COG grade surface mount capacitor. For this example, a 10-mm diameter Aluminum target of 1mm thickness is moved perpendicular to the plane of the sensor coil.

For this example, the target range of motion is from 1-mm to 3-mm distance from the sensor coil. The position of the target needs to be reported at a sample rate of 3 ksps. The PCB is a 4-layer construction with 0.1-mm (4 mils) minimum feature size.

### 9.2.2 Detailed Design Procedure

#### 9.2.2.1 Device Configuration for $R_p+L$ Measurement with an Example Sensor

The sensor described in [Table 39](#) meets the restrictions on size on construction. To use it for  $R_p+L$  measurement of a 10-mm diameter 1-mm thick aluminum target moving axially with respect to the sensor:

**Table 39. Example Sensor Characteristics**

PARAMETER	MINIMUM TARGET INTERACTION	STRONGEST TARGET INTERACTION
Inductance	5.47 $\mu$ H	5.15 $\mu$ H
Inductor Outer Diameter	10 mm	
Number of Turns	17	
Trace Spacing/ Trace Width	0.1 mm / 0.16 mm	
Number of Layers/Separation	2 / 0.355 mm	
Sensor Capacitance	270 pF	
Sensor Frequency	4.11 MHz	4.27 MHz
R <sub>S</sub>	3.2 $\Omega$ at 2.93 MHz	3.23 $\Omega$ at 4.27 MHz
R <sub>P</sub>	6.33 k $\Omega$ at 2.93 MHz	5.91 k $\Omega$ at 4.27 MHz
Q at 2.9 MHz	45	42

This sensor is within the LDC1101 sensor boundary conditions for frequency, Q, and R<sub>P</sub>. The first step is to determine the appropriate RPMIN/RPMAX and TC1/2 settings.

- Setting RPMAX has the constraint of  $R_{PD\infty} \leq R_{P\text{MAX}} \leq 2R_{PD\infty}$   
 $6.33 \text{ k}\Omega \leq R_{P\text{MAX}} \leq 12.22 \text{ k}\Omega \rightarrow$  Set RPMAX to 12 k $\Omega$
- RPMIN setting using the constraint of  $R_{P\text{MIN}} < 0.8 \times R_{PD0}$ :  
 $0.8 \times 3.20 \text{ k}\Omega = 2.6 \text{ k}\Omega \rightarrow$  Set RPMIN to 1.5 k $\Omega$ . Therefore, set RPMIN = 1.5 k $\Omega$ .
- Q Range: In step 4, the sensor Q range of 42 to 45 is within the operating range of 10 to 400. As the sensor Q value is below 50, it is not necessary to use HIGH\_Q\_SENSOR, and so HIGH\_Q\_SENSOR=0.
- Now set the Time Constant 1 using [Equation 8](#):  
 $R1 \times C1 = 0.75026 \div 4.11 \text{ MHz} = 1.8255\text{E-}7\text{s}$   
Starting with the largest C1 value of 6 pF for best noise performance results in R1 = 30.5 k $\Omega$ .  
This is within the R1 range of 20.6 k $\Omega$  to 417.4 k $\Omega$ , and so C1 = 6 pF can be used.  
Picking the next higher programmable value for R1  $\rightarrow$  Set R1 = 33.9 k $\Omega$ .
- Next, set the Time Constant 2 using [Equation 9](#):  
 $R2 \times C2 = 2 \times 1.5 \text{ k}\Omega \times 270 \text{ pF} = 8.100\text{E-}7\text{s}$   
Starting with the largest C2 value of 24 pF (once again, for best noise performance) results in R2 = 33.75 k $\Omega$ .  
This is within the programmable R2 value of 24.60 k $\Omega$  to 834.8 k $\Omega$ , and so 24 pF can be used for C2.  
Picking the next higher programmable value for R2  $\rightarrow$  Set R2 = 43.3 k $\Omega$ .
- Then configure the MIN\_FREQ field. The sensor minimum frequency is 4.11 MHz, which occurs with the minimum target interaction. Therefore, MIN\_FREQ is set to 14, which configures the watchdog for 4.0 MHz.
- Next, set the response time. Setting 6144 provides the highest resolution R<sub>P</sub> measurement with this sensor. With 6144 the sample rate is at least 2.01 kSPS. To attain highest resolution with a sample rate of >3 kSPS, the response time setting should be 3072.
- All other device settings can be in their default values.

**Table 40. LDC1101 Register Settings for RP+L Example Application**

FIELD	FIELD SETTING	FIELD VALUE	REGISTER	REGISTER VALUE
HIGH_Q_SENSOR	disabled	b0	RP_SET (0x01)	0x36
RPMAX	12.0 k $\Omega$	b011		
RPMIN	1.5 k $\Omega$	b110		
C1	6 pF	b11	TC1 (0x02)	0xDE
R1	33.9 k $\Omega$	b1'1110		
C2	24 pF	b11	TC2 (0x03)	0xFE
R2	43.3 k $\Omega$	b11'1110		

**Table 40. LDC1101 Register Settings for RP+L Example Application (continued)**

FIELD	FIELD SETTING	FIELD VALUE	REGISTER	REGISTER VALUE
MIN_FREQ	4.0 MHz	b1110	DIG_CONF (0x04)	0xE6
RESP_TIME	3072	b110		
FUNC_MODE	active	b00	START_CONFIG (0x0B)	0x00

On power-up, the LDC1101 enters Sleep mode, which is a low power mode used to configure the LDC. If the LDC1101 is actively converting, write 0x01 to START\_CONFIG (address 0x0B) to stop conversions before writing the settings above.

Once the LDC1101 is configured, the process to retrieve RP+L conversion results is:

1. Set the LDC1101 into conversion mode (active mode) by writing 0x00 to START\_CONFIG (register 0x0B).
2. Poll STATUS.DRDYB (register 0x20:bit6) until it indicates a conversion result is present, or use the INTB signal reporting as described in [DRDY \(Data Ready\) Reporting on SDO](#).
3. If the desired measurement is  $R_P$ , then read back registers 0x21 and 0x22. The  $R_P$  output code is the contents of register 0x21 + 256 × (contents of register 0x22).
4. If the desired measurement is L, then read back registers 0x23 and 0x24. The L output code is the contents of register 0x23 + 256 × (contents of register 0x24). Reading both  $R_P$  and L is permitted, for a more efficient operation  $R_P$  and L registers can be retrieved in a single extended SPI transaction as described in [SPI Programming](#).
5. Process the conversion results on the MCU and repeat from step 2 if additional conversions are desired. If no additional conversions are required, place the LDC1101 into Sleep mode or Shutdown mode.

### 9.2.2.2 Device Configuration for LHR Measurement with an Example Sensor

The LDC1101 can be configured for either  $R_P$  and inductance (L) measurements or to only perform inductance (L) measurements. If the LDC1101 is to measure both  $R_P$  and inductance, configure the  $R_P$  measurement as described above. If only L measurements are needed, then configure the device for this operation as detailed in [Setting R<sub>P</sub>MIN for LHR Measurements](#).

Given a sensor with characteristics as shown in [Table 39](#), the steps to configure the LDC1101 for LHR measurements are:

1. Determine the device sample rate, based on system requirements, using [Equation 14](#). For this example,  $f_{CLKIN} = 16$  MHz and a sample rate of 3 kSPS is necessary. The number of cycles of the  $f_{CLKIN}$  that closest fit the desired sample rate is determined by:  
 $1/(3 \text{ kSPS}) = 333.3 \mu\text{s}$   
 subtracting the conversion post-processing time of 55 reference clock cycles ( $55/16 \text{ MHz} = 3.437 \mu\text{s}$ ):  
 $333.3 \mu\text{s} - 3.437 \mu\text{s} = 329.9 \mu\text{s} \rightarrow 16 \text{ MHz} \times 329.9 \mu\text{s} = 5278.33 \rightarrow 5278.33/16 = 329.9$   
 Programming RCOUNT to 330 (0x014A) results in a sample rate of 2.999 kSPS.
2. Next, set the sensor drive current. If the sensor was already configured for RP+L measurements with the steps in [Device Configuration for RP+L Measurement with an Example Sensor](#), then the sensor drive is already configured and no additional steps are necessary.
3. If the sensor drive current needs to be configured, from [Table 36](#), 3 kΩ is the appropriate setting for the sensor  $R_P$  range of 6.33 kΩ to 5.91 kΩ.

**Table 41. LDC1101 Register Settings for LHR Example Application**

FIELD	FIELD SETTING	FIELD VALUE	REGISTER	REGISTER VALUE
HIGH_Q_SENSOR	disabled	b0	RP_SET (0x01)	0x75
RPMAX	doesn't matter if device configured for L-Only measurements	b011		
RPMIN	1.5 kΩ	b101		
MIN_FREQ	4.0 MHz	b1110	DIG_CONF (0x04)	0xE7
RESP_TIME	don't care	b111		
RCOUNT	5280	330	LHR_RCOUNT_LSB (0x30)	0x4A
			LHR_RCOUNT_MSB (0x31)	0x01

Table 41. LDC1101 Register Settings for LHR Example Application (continued)

FIELD	FIELD SETTING	FIELD VALUE	REGISTER	REGISTER VALUE
FUNC_MODE	active	b00	START_CONFIG (0x0B)	0x00

Once the LDC1101 is configured, the process to retrieve LHR conversion results is:

1. Set the LDC1101 into conversion mode (active mode) by writing 0x00 to START\_CONFIG (register 0x0B).
2. Poll LHR\_STATUS.DRDYB (register 0x3B:bit0) until it indicates a conversion result is present, or use the INTB signal reporting as described in [DRDY \(Data Ready\) Reporting on SDO](#).
3. Read back registers 0x38, 0x39, and 0x3A. These registers can be retrieved in a single extended SPI transaction as described in [SPI Programming](#).
4. Process the conversion results on the MCU and repeat from step 2 if additional conversions are desired. If no additional conversions are required, place the LDC1101 into Sleep mode or Shutdown mode.

Both sets of conversion results can be retrieved when the conversions complete. Note that the RP+L conversions do not complete at the same time as LHR conversions.

### 9.2.3 Application Curves

The RCOUNT = 0x00FF curve, which corresponds to a sample rate of 3.87 ksp/s, measures the target position with a slightly lower resolution than the RCOUNT = 0x014A used in this example. Over the target movement range of 3 mm, which corresponds to the normalized value of 0.3 on the Axial Measurement graph, the target position can be resolved to 4 μm.

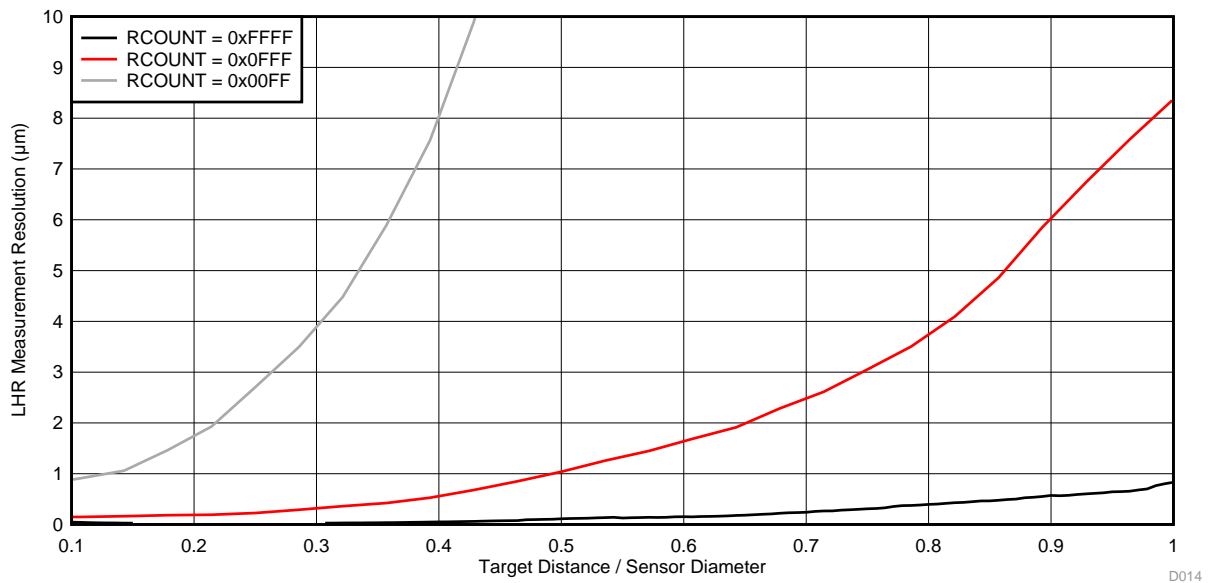
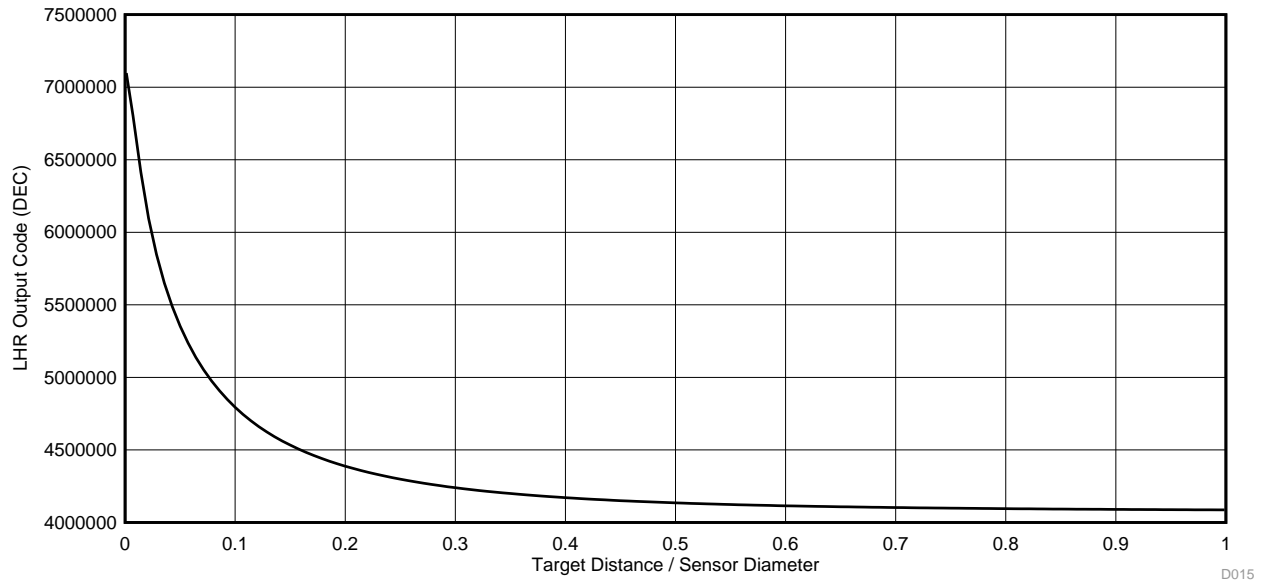

Figure 59. LHR Axial Measurement Resolution vs Normalized Distance for Aluminum Target



**Figure 60. LHR Output Code vs Normalized Distance for Aluminum Target**

## 10 Power Supply Recommendations

A parallel set of 1- $\mu$ F and 0.1- $\mu$ F capacitors must be used to bypass  $V_{DD}$ , although it may be necessary to include a larger capacitor with systems which have a larger amount of supply variation. The smallest value capacitor should be placed as close to the VDD pin as possible. A ground plane is recommended to connect both the ground and the die attach pad (DAP).

$C_{LDO}$  capacitor must be nonpolarized and have an equivalent series resistance (ESR) less than 1  $\Omega$ , with a SRF of at least 24 MHz.

## 11 Layout

### 11.1 Layout Guidelines

The LDC1101 requires minimal external components for effective operation. Following good layout techniques providing good grounding and clean supplies are critical for optimum operation. Due to the small physical size of the LDC1101, use of surface mount 0402 or smaller components can ease routing.

#### 11.1.1 Ground and Power Planes

Ground and power planes are helpful for maintaining a clean supply to the LDC1101. In the layout shown in [Figure 61](#), a top-layer ground fill is also used for improved grounding.

#### 11.1.2 CLKIN Routing

The CLKIN pin routing must maintain consistent impedance; typically this is 50  $\Omega$ , but can be adjusted based on board geometries. If a parallel termination resistor is used, it must be placed as close to the CLKIN pin as possible. Minimize layer changes and routing through vias for the CLKIN signal. Maintain an uninterrupted ground plane under the trace.

#### 11.1.3 Capacitor Placement

The capacitor  $C_{LDO}$  must be placed as close to the CLDO pin as possible.

Place the bypass capacitors as close to the VDD pin as possible, with the smaller valued capacitor placed closer.

#### 11.1.4 Sensor Connections

The sensor capacitor must be as close to the sensor inductor as possible. The INA and INB traces must be routed in parallel and as close to each other as possible to minimize coupling of noise. If cable is to be used, then INA and INB should be a twisted pair or in coaxial cable. The distance between the INA/INB pins and the sensor affects the maximum possible sensor frequency. For some applications, it may be helpful to place small-value capacitor (for example, 10 pF) from INA to ground and INB to ground; these capacitors should be located close to the INA and INB pins.

Refer to Application Note *LDC Sensor Design* ([SNOA930](#)) for additional information on sensor design.

## 11.2 Layout Example

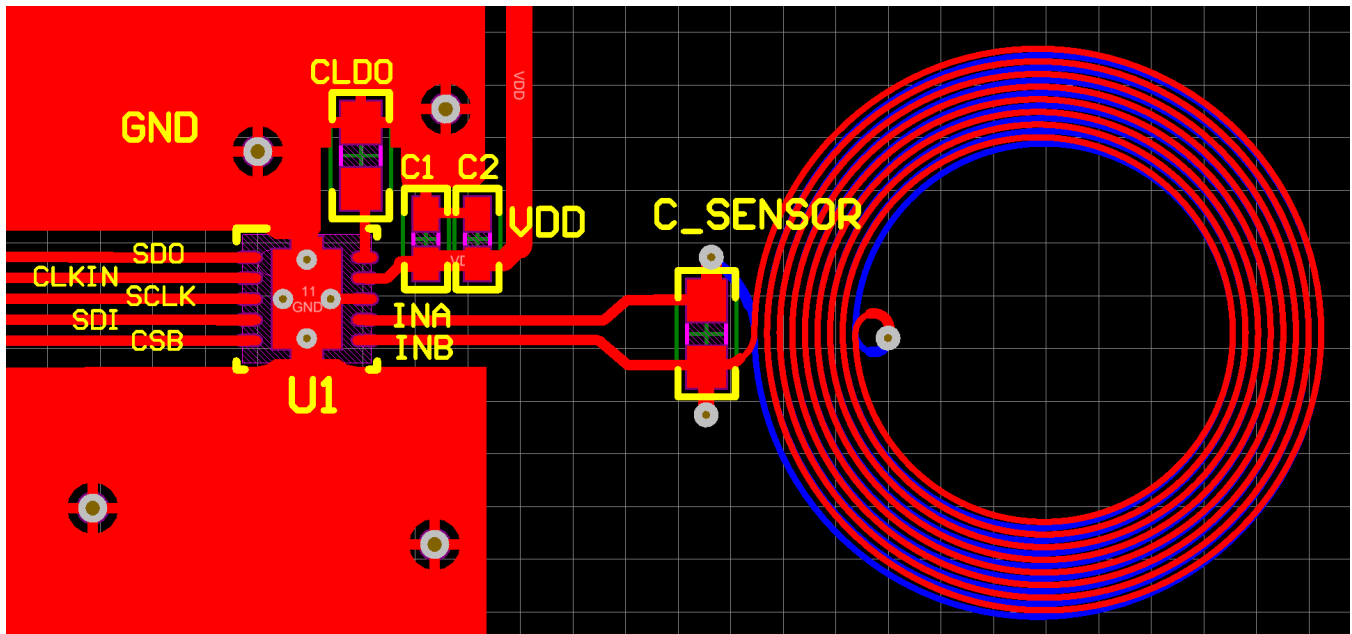

Figure 61. Layout Recommendations

## 12 Device and Documentation Support

### 12.1 Device Support

#### 12.1.1 Development Support

For on-line LDC system design tools, see [Texas Instruments' Webench® Tool](#).

The [LDC Calculator tools](#) provides a collection of calculation tools which run under MS Excel® useful for LDC system development.

### 12.2 Documentation Support

#### 12.2.1 Related Documentation

For detailed information on LDC sensor design, refer to the application report [LDC Sensor Design](#).

For detailed information on lateral position sensing with an LDC, in which a target is moved at a constant height from a sensor and the offset is to be measured, refer to [LDC1612/LDC1614 Linear Position Sensing](#). The LDC1101 LHR mode is functionally equivalent to a single channel LDC1612/LDC1614.

For information on temperature compensation, refer to [LDC1000 Temperature Compensation](#).

The following resources contain additional information on LDC1101 operation, configuration, and system design:

- [Inductive Linear Position Sensing Using the LDC1101](#)
- [Inductive Proximity Switch Using the LDC1101](#)
- [LDC Selection Guide Application Report](#)
- [LDC Sensor Design Application Report](#)
- [LDC Target Design Application Report](#)
- [Performing L Measurements from LDC DRDY Timing Application Report](#)
- [Optimizing L Measurement Resolution for the LDC161x and LDC1101 Application Report](#)
- [Measuring  \$R\_p\$  of an L-C Sensor for Inductive Sensing Application Report](#)
- [Setting LDC1312/4, LDC1612/4, and LDC1101 Sensor Drive Configuration Application Report](#)

### 12.3 Community Resources

The following links connect to TI community resources. Linked contents are provided "AS IS" by the respective contributors. They do not constitute TI specifications and do not necessarily reflect TI's views; see TI's [Terms of Use](#).

**TI E2E™ Online Community** *TI's Engineer-to-Engineer (E2E) Community*. Created to foster collaboration among engineers. At [e2e.ti.com](http://e2e.ti.com), you can ask questions, share knowledge, explore ideas and help solve problems with fellow engineers.

**Design Support** *TI's Design Support* Quickly find helpful E2E forums along with design support tools and contact information for technical support.

### 12.4 Trademarks

E2E is a trademark of Texas Instruments.

Webench is a registered trademark of Texas Instruments.

Excel is a registered trademark of Microsoft Corporation.

SPI is a trademark of Motorola.

All other trademarks are the property of their respective owners.

### 12.5 Electrostatic Discharge Caution



These devices have limited built-in ESD protection. The leads should be shorted together or the device placed in conductive foam during storage or handling to prevent electrostatic damage to the MOS gates.

## 12.6 Glossary

[SLYZ022](#) — *TI Glossary*.

This glossary lists and explains terms, acronyms, and definitions.

## 13 Mechanical, Packaging, and Orderable Information

The following pages include mechanical, packaging, and orderable information. This information is the most current data available for the designated devices. This data is subject to change without notice and revision of this document. For browser-based versions of this data sheet, refer to the left-hand navigation.

**PACKAGING INFORMATION**

Orderable Device	Status (1)	Package Type	Package Drawing	Pins	Package Qty	Eco Plan (2)	Lead/Ball Finish (6)	MSL Peak Temp (3)	Op Temp (°C)	Device Marking (4/5)	Samples
LDC1101DRCR	ACTIVE	VSON	DRC	10	3000	Green (RoHS & no Sb/Br)	CU NIPDAU	Level-2-260C-1 YEAR	-40 to 125	L1101	<a href="#">Samples</a>
LDC1101DRCT	ACTIVE	VSON	DRC	10	250	Green (RoHS & no Sb/Br)	CU NIPDAU	Level-2-260C-1 YEAR	-40 to 125	L1101	<a href="#">Samples</a>

(1) The marketing status values are defined as follows:

**ACTIVE:** Product device recommended for new designs.

**LIFEBUY:** TI has announced that the device will be discontinued, and a lifetime-buy period is in effect.

**NRND:** Not recommended for new designs. Device is in production to support existing customers, but TI does not recommend using this part in a new design.

**PREVIEW:** Device has been announced but is not in production. Samples may or may not be available.

**OBSELETE:** TI has discontinued the production of the device.

(2) Eco Plan - The planned eco-friendly classification: Pb-Free (RoHS), Pb-Free (RoHS Exempt), or Green (RoHS & no Sb/Br) - please check <http://www.ti.com/productcontent> for the latest availability information and additional product content details.

**TBD:** The Pb-Free/Green conversion plan has not been defined.

**Pb-Free (RoHS):** TI's terms "Lead-Free" or "Pb-Free" mean semiconductor products that are compatible with the current RoHS requirements for all 6 substances, including the requirement that lead not exceed 0.1% by weight in homogeneous materials. Where designed to be soldered at high temperatures, TI Pb-Free products are suitable for use in specified lead-free processes.

**Pb-Free (RoHS Exempt):** This component has a RoHS exemption for either 1) lead-based flip-chip solder bumps used between the die and package, or 2) lead-based die adhesive used between the die and leadframe. The component is otherwise considered Pb-Free (RoHS compatible) as defined above.

**Green (RoHS & no Sb/Br):** TI defines "Green" to mean Pb-Free (RoHS compatible), and free of Bromine (Br) and Antimony (Sb) based flame retardants (Br or Sb do not exceed 0.1% by weight in homogeneous material)

(3) MSL, Peak Temp. - The Moisture Sensitivity Level rating according to the JEDEC industry standard classifications, and peak solder temperature.

(4) There may be additional marking, which relates to the logo, the lot trace code information, or the environmental category on the device.

(5) Multiple Device Markings will be inside parentheses. Only one Device Marking contained in parentheses and separated by a "~" will appear on a device. If a line is indented then it is a continuation of the previous line and the two combined represent the entire Device Marking for that device.

(6) Lead/Ball Finish - Orderable Devices may have multiple material finish options. Finish options are separated by a vertical ruled line. Lead/Ball Finish values may wrap to two lines if the finish value exceeds the maximum column width.

**Important Information and Disclaimer:** The information provided on this page represents TI's knowledge and belief as of the date that it is provided. TI bases its knowledge and belief on information provided by third parties, and makes no representation or warranty as to the accuracy of such information. Efforts are underway to better integrate information from third parties. TI has taken and continues to take reasonable steps to provide representative and accurate information but may not have conducted destructive testing or chemical analysis on incoming materials and chemicals. TI and TI suppliers consider certain information to be proprietary, and thus CAS numbers and other limited information may not be available for release.

In no event shall TI's liability arising out of such information exceed the total purchase price of the TI part(s) at issue in this document sold by TI to Customer on an annual basis.

## TAPE AND REEL INFORMATION



### QUADRANT ASSIGNMENTS FOR PIN 1 ORIENTATION IN TAPE



\*All dimensions are nominal

Device	Package Type	Package Drawing	Pins	SPQ	Reel Diameter (mm)	Reel Width W1 (mm)	A0 (mm)	B0 (mm)	K0 (mm)	P1 (mm)	W (mm)	Pin1 Quadrant
LDC1101DRCR	VSON	DRC	10	3000	330.0	12.4	3.3	3.3	1.1	8.0	12.0	Q2
LDC1101DRCT	VSON	DRC	10	250	180.0	12.4	3.3	3.3	1.1	8.0	12.0	Q2

**TAPE AND REEL BOX DIMENSIONS**

\*All dimensions are nominal

Device	Package Type	Package Drawing	Pins	SPQ	Length (mm)	Width (mm)	Height (mm)
LDC1101DRCR	VSON	DRC	10	3000	367.0	367.0	35.0
LDC1101DRCT	VSON	DRC	10	250	210.0	185.0	35.0

## GENERIC PACKAGE VIEW

DRC 10

VSON - 1 mm max height

PLASTIC SMALL OUTLINE - NO LEAD

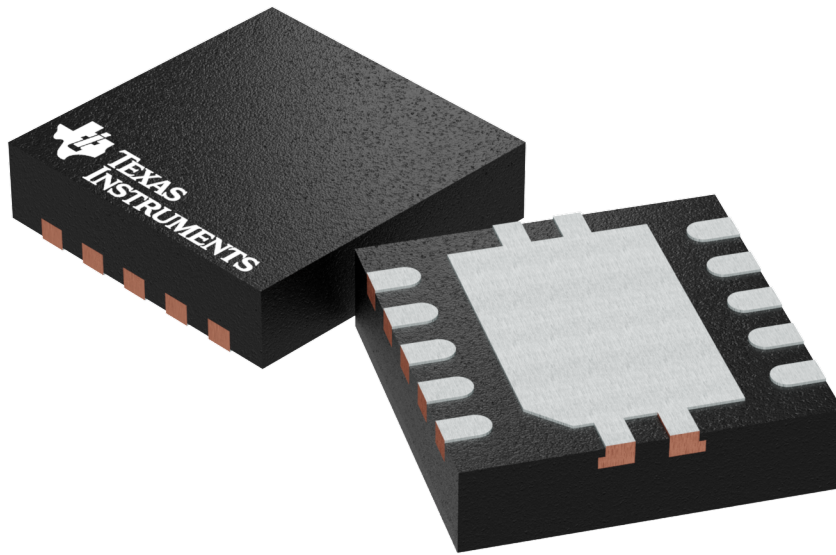

Images above are just a representation of the package family, actual package may vary.  
Refer to the product data sheet for package details.

4204102-3/M



# EXAMPLE BOARD LAYOUT

DRC0010J

VSON - 1 mm max height

PLASTIC SMALL OUTLINE - NO LEAD

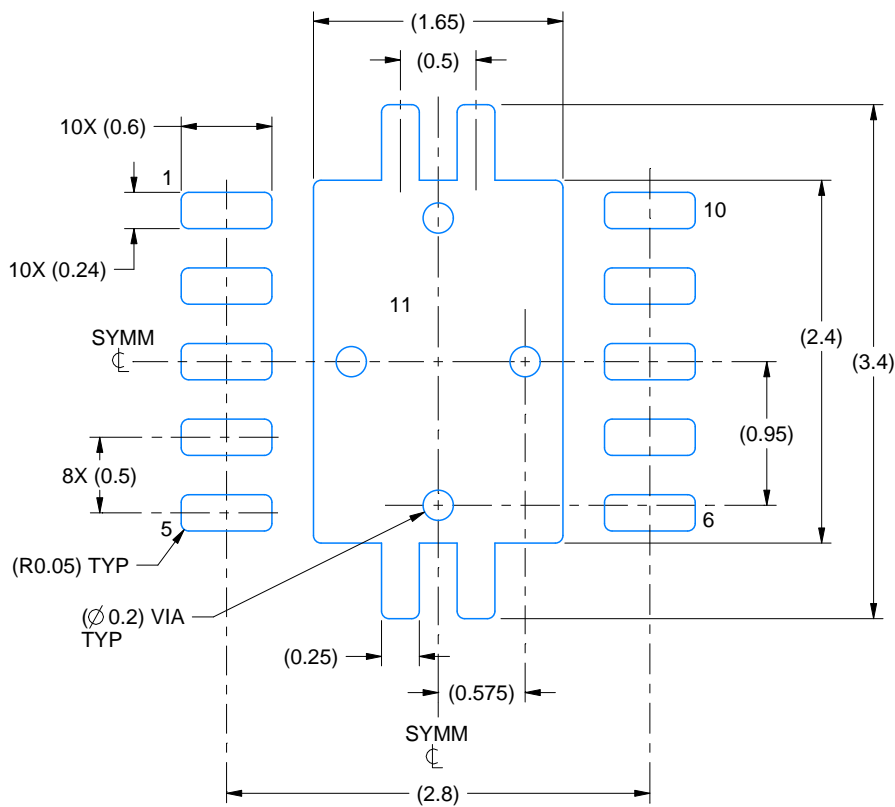

LAND PATTERN EXAMPLE  
EXPOSED METAL SHOWN  
SCALE:20X

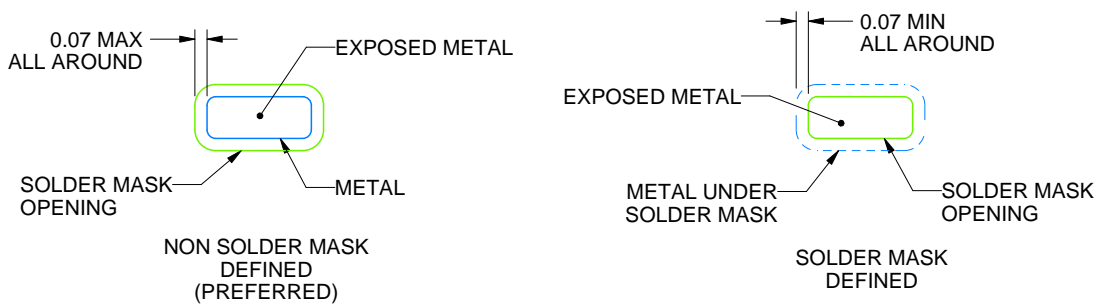

SOLDER MASK DETAILS

4218878/B 07/2018

NOTES: (continued)

4. This package is designed to be soldered to a thermal pad on the board. For more information, see Texas Instruments literature number SLUA271 ([www.ti.com/lit/sluea271](http://www.ti.com/lit/sluea271)).
5. Vias are optional depending on application, refer to device data sheet. If any vias are implemented, refer to their locations shown on this view. It is recommended that vias under paste be filled, plugged or tented.

# EXAMPLE STENCIL DESIGN

DRC0010J

VSON - 1 mm max height

PLASTIC SMALL OUTLINE - NO LEAD

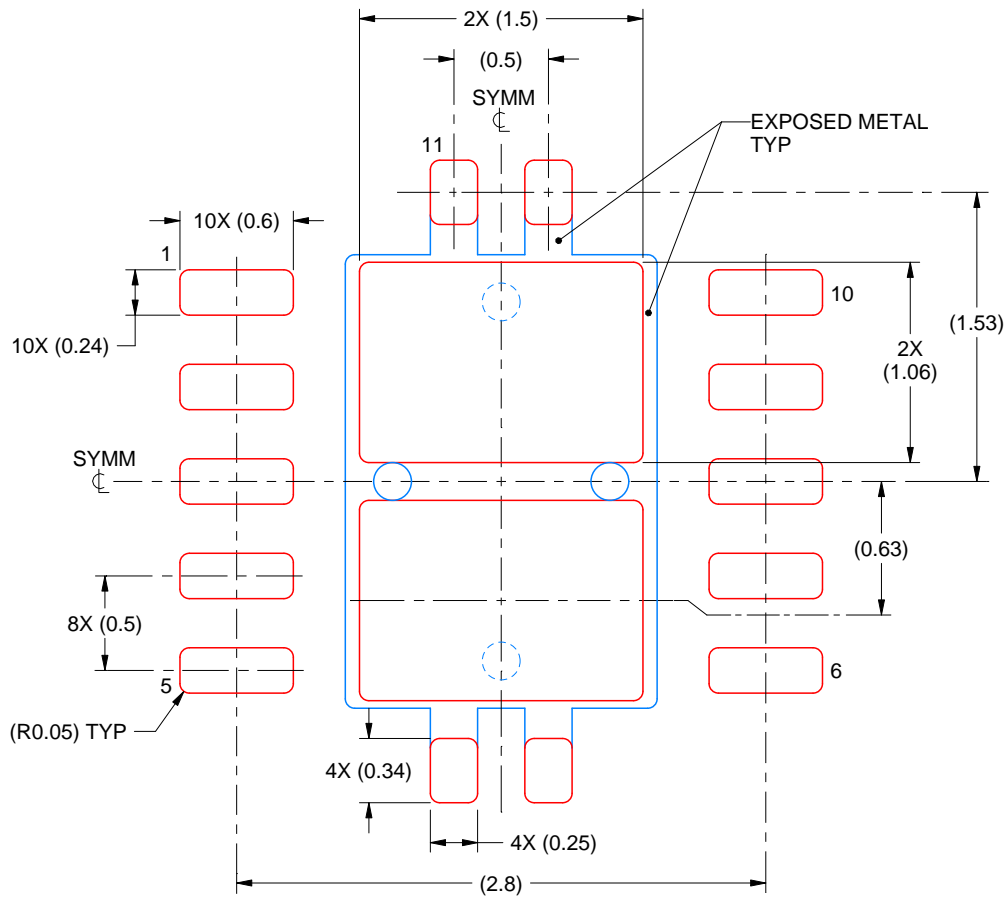

SOLDER PASTE EXAMPLE  
BASED ON 0.125 mm THICK STENCIL

EXPOSED PAD 11:  
80% PRINTED SOLDER COVERAGE BY AREA  
SCALE:25X

4218878/B 07/2018

NOTES: (continued)

6. Laser cutting apertures with trapezoidal walls and rounded corners may offer better paste release. IPC-7525 may have alternate design recommendations.

## IMPORTANT NOTICE AND DISCLAIMER

TI PROVIDES TECHNICAL AND RELIABILITY DATA (INCLUDING DATASHEETS), DESIGN RESOURCES (INCLUDING REFERENCE DESIGNS), APPLICATION OR OTHER DESIGN ADVICE, WEB TOOLS, SAFETY INFORMATION, AND OTHER RESOURCES "AS IS" AND WITH ALL FAULTS, AND DISCLAIMS ALL WARRANTIES, EXPRESS AND IMPLIED, INCLUDING WITHOUT LIMITATION ANY IMPLIED WARRANTIES OF MERCHANTABILITY, FITNESS FOR A PARTICULAR PURPOSE OR NON-INFRINGEMENT OF THIRD PARTY INTELLECTUAL PROPERTY RIGHTS.

These resources are intended for skilled developers designing with TI products. You are solely responsible for (1) selecting the appropriate TI products for your application, (2) designing, validating and testing your application, and (3) ensuring your application meets applicable standards, and any other safety, security, or other requirements. These resources are subject to change without notice. TI grants you permission to use these resources only for development of an application that uses the TI products described in the resource. Other reproduction and display of these resources is prohibited. No license is granted to any other TI intellectual property right or to any third party intellectual property right. TI disclaims responsibility for, and you will fully indemnify TI and its representatives against, any claims, damages, costs, losses, and liabilities arising out of your use of these resources.

TI's products are provided subject to TI's Terms of Sale ([www.ti.com/legal/termsofsale.html](http://www.ti.com/legal/termsofsale.html)) or other applicable terms available either on [ti.com](http://ti.com) or provided in conjunction with such TI products. TI's provision of these resources does not expand or otherwise alter TI's applicable warranties or warranty disclaimers for TI products.

Mailing Address: Texas Instruments, Post Office Box 655303, Dallas, Texas 75265  
Copyright © 2019, Texas Instruments Incorporated

## Looking for pricing, stock, or lifecycle information?

Click below to explore more details on WIN SOURCE:

 [View LDC1101DRCT](#) on WIN SOURCE

 [Texas Instruments](#) Information

## Optimize Your Supply Chain with WIN SOURCE Solutions

-  Global Sourcing Solution
-  Obsolete Management
-  Cost Control Management
-  Shortage Management
-  Alternative Solution
-  Excess Inventory Management