



CCB LC72121MA

CMOS IC

PLL Frequency Synthesizers for Electronic Tuning

ON Semiconductor®

<http://onsemi.com>

Overview

The LC72121MA are high input sensitivity (20mVrms at 130MHz) PLL frequency synthesizers for 3V systems. These ICs are serial data (CCB) compatible with the LC72131K/KMA, and feature the improved input sensitivity and lower spurious radiation (provided by a redesigned ground system) required in high-performance AM/FM tuners.

Features

- High-speed programmable divider
 - FMIN: 10 to 160MHz Pulse swallower technique (With built-in divide-by-2 prescaler)
 - AMIN: 2 to 40MHz Pulse swallower technique
 - 0.5 to 10MHz Direct division technique
- IF counter
 - IFIN: 0.4 to 15MHz For AM and FM IF counting
- Reference frequency
 - One of 12 reference frequencies can be selected (using a 4.5 or 7.2MHz crystal element)
 - 1, 3, 5, 9, 10, 3.125, 6.25, 12.5, 15, 25, 50, and 100kHz
- Phase comparator
 - Supports dead zone control. • Built-in unlocked state detection circuit • Built-in deadlock clear circuit
 - An MOS transistor for an active low-pass filter is built in.
- I/O ports
 - Output-only ports: 4 pins • I/O ports: 2 pins • Supports the output of a clock time base signal.
- Serial data I/O
 - Support CCB format communication with the system controller.
- Operating ranges
 - Supply voltage: 2.7 to 3.6V • Operating temperature: -40 to +85°C
- Package
 - MFP24SJ

• CCB is ON Semiconductor®'s original format. All addresses are managed by ON Semiconductor® for this format.

- CCB is a registered trademark of Semiconductor Components Industries, LLC.

LC72121MA

Specifications

Absolute Maximum Ratings at $T_a = 25^\circ\text{C}$, $V_{SSd} = V_{SSa} = V_{SSX} = 0\text{V}$

Parameter	Symbol	Conditions	Ratings	Unit
Maximum supply voltage	V_{DD} max	V_{DD}	-0.3 to +7.0	V
Maximum input voltage	V_{IN1} max	CE, CL, DI, AIN	-0.3 to +7.0	V
	V_{IN2} max	XIN, FMIN, AMIN, IFIN	-0.3 to $V_{DD}+0.3$	V
	V_{IN3} max	$\overline{IO1}$, $\overline{IO2}$	-0.3 to +15	V
Maximum output voltage	V_{O1} max	DO	-0.3 to +7.0	V
	V_{O2} max	XOUT, PD	-0.3 to $V_{DD}+0.3$	V
	V_{O3} max	$\overline{BO1}$ to $\overline{BO4}$, $\overline{IO1}$, $\overline{IO2}$, AOUT	-0.3 to +15	V
Maximum output current	I_{O1} max	DO, AOUT	0 to 6.0	mA
	I_{O2} max	$\overline{BO1}$ to $\overline{BO4}$, $\overline{IO1}$, $\overline{IO2}$	0 to 10	mA
Allowable power dissipation	P_d max	($T_a \leq 85^\circ\text{C}$)	200	mW
Operating temperature	T_{opr}		-40 to +85	$^\circ\text{C}$
Storage temperature	T_{stg}		-55 to +125	$^\circ\text{C}$

Note 1: Power pins V_{DD} and V_{SS} : Insert a capacitor with a capacitance of 2,000pF or higher between these pins when using the IC.

Stresses exceeding Maximum Ratings may damage the device. Maximum Ratings are stress ratings only. Functional operation above the Recommended Operating Conditions is not implied. Extended exposure to stresses above the Recommended Operating Conditions may affect device reliability.

Allowable Operating Ranges at $T_a = -40$ to $+85^\circ\text{C}$, $V_{SSd} = V_{SSa} = V_{SSX} = 0\text{V}$

Parameter	Symbol	Pin	Conditions	Ratings			Unit
				min	typ	max	
Supply voltage	V_{DD}	V_{DD}		2.7		3.6	V
Input high-level voltage	V_{IH1}	CE, CL, DI		$0.7V_{DD}$		6.5	V
	V_{IH2}	$\overline{IO1}$, $\overline{IO2}$		$0.7V_{DD}$		13	V
Input low-level voltage	V_{IL}	CE, CL, DI, $\overline{IO1}$, $\overline{IO2}$		0		$0.3V_{DD}$	V
Output voltage	V_{O1}	DO		0		6.5	V
	V_{O2}	$\overline{BO1}$ to $\overline{BO4}$, $\overline{IO1}$, $\overline{IO2}$, AOUT		0		13	V
Input frequency	f_{IN1}	XIN	V_{IN1}	1.0		8.0	MHz
	f_{IN2}	FMIN	V_{IN2}	10		160	MHz
	f_{IN3}	AMIN	$V_{IN3}(\text{SNS}=1)$	2.0		40	MHz
	f_{IN4}	AMIN	$V_{IN4}(\text{SNS}=0)$	0.5		10	MHz
	f_{IN5}	IFIN	V_{IN5}	0.4		15	MHz
Guaranteed crystal oscillator frequency	X'tal	XIN, XOUT	Note 2	4.0		8.0	MHz
Input amplitude	V_{IN1}	XIN	f_{IN1}	200		800	mVrms
	V_{IN2-1}	FMIN	$f=10$ to 130MHz	20		800	mVrms
	V_{IN2-2}	FMIN	$f=130$ to 160MHz	40		800	mVrms
	V_{IN3}	AMIN	$f_{IN3}(\text{SNS}=1)$	40		800	mVrms
	V_{IN4}	AMIN	$f_{IN4}(\text{SNS}=0)$	40		800	mVrms
	V_{IN5}	IFIN	$f_{IN5}(\text{IFS}=1)$	40		800	mVrms
	V_{IN6}	IFIN	$f_{IN5}(\text{IFS}=0)$	70		800	mVrms
Data setup time	t_{SU}	DI, CL	Note 3	0.75			μs
Data hold time	t_{HD}	DI, CL	Note 3	0.75			μs
Clock low level time	t_{CL}	CL	Note 3	0.75			μs
Clock high level time	t_{CH}	CL	Note 3	0.75			μs
CE wait time	t_{EL}	CE, CL	Note 3	0.75			μs
CE setup time	t_{ES}	CE, CL	Note 3	0.75			μs
CE hold time	t_{EH}	CE, CL	Note 3	0.75			μs
Data latch change time	t_{LC}		Note 3			0.75	μs
Data output time	t_{DC}	DO, CL	Differs depending on the value of the pull-up resistor. Note 3				μs
	t_{DH}	DO, CE				0.35	

LC72121MA

Note 2: Recommended crystal oscillator CI values:

$CI \leq 120\Omega$ (For a 4.5MHz crystal)

$CI \leq 70\Omega$ (For a 7.2MHz crystal)

The characteristics of the oscillation circuit depends on the printed circuit board, circuit constants, and other factors. Therefore we recommend consulting with the manufacturer of the crystal for evaluation and reliability.

Note 3: Refer to "Serial Data Timing".

Electrical Characteristics in the Allowable Operating Ranges

Parameter	Symbol	Pin	Conditions	Ratings			Unit
				min	typ	max	
Internal feedback resistance	Rf1	XIN			1.0		M Ω
	Rf2	FMIN			500		k Ω
	Rf3	AMIN			500		k Ω
	Rf4	IFIN			250		k Ω
Internal pull-down resistance	Rpd1	FMIN		100	200	400	k Ω
	Rpd2	AMIN		100	200	400	k Ω
Hysteresis	V _{HIS}	CE, CL, DI			0.1V _{DD}		V
Output high-level voltage	V _{OH}	PD	I _O =-1mA	V _{DD} -1.0			V
Output low-level voltage	V _{OL1}	PD	I _O =1mA			1.0	V
	V _{OL2}	$\overline{BO1}$ to $\overline{BO4}$, $\overline{IO1}$, $\overline{IO2}$	I _O =1mA			0.2	V
			I _O =8mA			1.6	V
	V _{OL3}	DO	I _O =1mA			0.2	V
I _O =5mA					1.0	V	
V _{OL4}	AOUT	I _O =1mA, AIN=1.3V			0.5	V	
Input high-level current	I _{IH1}	CE, CL, DI	V _I =6.5V			5.0	μ A
	I _{IH2}	$\overline{IO1}$, $\overline{IO2}$	V _I =13V			5.0	μ A
	I _{IH3}	XIN	V _I =V _{DD}	1.3		8	μ A
	I _{IH4}	FMIN, AMIN	V _I =V _{DD}	2.5		15	μ A
	I _{IH5}	IFIN	V _I =V _{DD}	5.0		30	μ A
	I _{IH6}	AIN	V _I =6.5V			200	nA
Input low-level current	I _{IL1}	CE, CL, DI	V _I =0V			5.0	μ A
	I _{IL2}	$\overline{IO1}$, $\overline{IO2}$	V _I =0V			5.0	μ A
	I _{IL3}	XIN	V _I =0V	1.3		8	μ A
	I _{IL4}	FMIN, AMIN	V _I =0V	2.5		15	μ A
	I _{IL5}	IFIN	V _I =0V	5.0		30	μ A
	I _{IL6}	AIN	V _I =0V			200	nA
Output off leakage current	I _{OFF1}	$\overline{BO1}$ to $\overline{BO4}$, AOUT, $\overline{IO1}$, $\overline{IO2}$	V _O =13V			5.0	μ A
	I _{OFF2}	DO	V _O =6.5V			5.0	μ A
High-level 3-state off leakage current	I _{OFFH}	PD	V _O =V _{DD}		0.01	200	nA
Low-level 3-state off leakage current	I _{OFFL}	PD	V _O =0V		0.01	200	nA
Input capacitance	C _{IN}	FMIN			6		pF
Supply current	I _{DD1}	V _{DD}	X'tal=7.2MHz f _{IN2} =130MHz V _{IN2} =20mVrms		2.5	6	mA
	I _{DD2}	V _{DD}	PLL block stopped (PLL INHIBIT mode) Crystal oscillator operating (crystal frequency: 7.2 MHz)		0.3		mA
	I _{DD3}	V _{DD}	PLL block stopped. Crystal oscillator stopped.			10	μ A

LC72121MA

Package Dimensions

unit : mm (typ)

3419

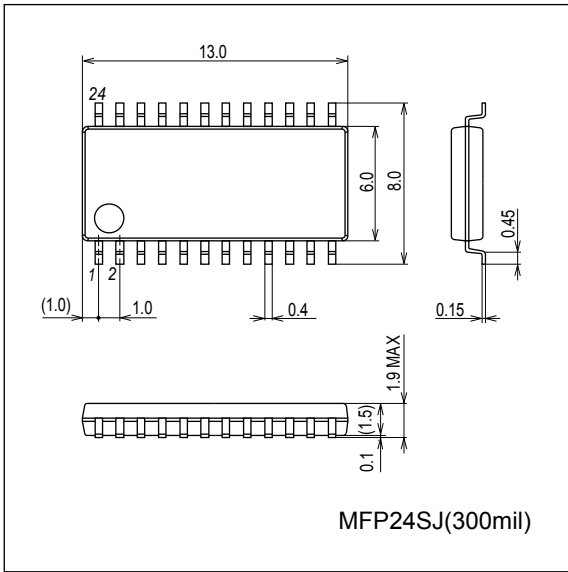

Pin Assignment

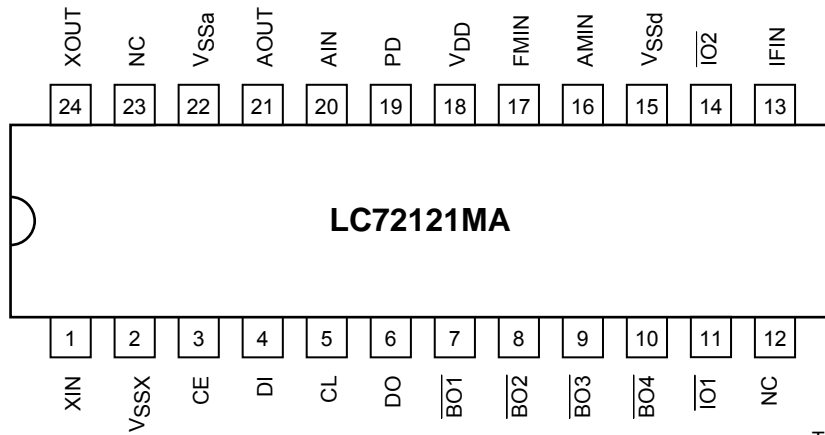

Top view

LC72121MA

Pin Descriptions

Pin name	Pin No.	Type	Function	Equivalent circuit
XIN XOUT	1 24	X'tal OSC	<ul style="list-style-type: none"> Crystal oscillator element connections (4.5 or 7.2 MHz) 	
FMIN	17	Local oscillator signal input	<ul style="list-style-type: none"> FMIN is selected when DVS in the serial data is set to 1. Input frequency: 10 to 160MHz The signal is passed through an internal divide-by-two prescaler and then input to the swallow counter. The divisor can be set to a value in the range 272 to 65535. Since the internal divide-by-two prescaler is used, the actual divisor will be twice the set value. 	
AMIN	16	Local oscillator signal input	<ul style="list-style-type: none"> AMIN is selected when DVS in the serial data is set to 0. When SNS in the serial data is set to 1: <ul style="list-style-type: none"> Input frequency: 2 to 40MHz The signal is input to the swallow counter directly. The divisor can be set to a value in the range 272 to 65535. The set value becomes the actual divisor. When SNS in the serial data is set to 0: <ul style="list-style-type: none"> Input frequency: 0.5 to 10MHz The signal is input to a 12-bit programmable divider directly. The divisor can be set to a value in the range 4 to 4095. The set value becomes the actual divisor. 	
CE	3	Chip enable	<ul style="list-style-type: none"> This pin must be set high to enable serial data input (DI) or serial data output (DO). 	
DI	4	Input data	<ul style="list-style-type: none"> Input for serial data transferred from the controller 	
CL	5	Clock	<ul style="list-style-type: none"> Clock used for data synchronization for serial data input (DI) and serial data output (DO). 	
DO	6	Output data	<ul style="list-style-type: none"> Output for serial data transmitted to the controller. The content of the data transmitted is determined by DOC0 through DOC2. 	
V _{DD}	18	Power supply	<ul style="list-style-type: none"> LC72121MA power supply (V_{DD} 2.7 to 3.6V) The power on reset circuit operates when power is first applied. 	-
V _{SSX}	2	Ground	<ul style="list-style-type: none"> Ground for the crystal oscillator circuit 	-
V _{SSd}	15	Ground	<ul style="list-style-type: none"> Ground for the LC72121MA digital systems other than those that use V_{SSa} or V_{SSX}. 	-
$\overline{\text{BO1}}$ $\overline{\text{BO2}}$ $\overline{\text{BO3}}$ $\overline{\text{BO4}}$	7 8 9 10	Output port	<ul style="list-style-type: none"> Output-only ports The output state is determined by BO1 through BO4 in the serial data. <ul style="list-style-type: none"> When the data value is 0: The output state will be the open circuit state. When the data value is 1: The output state will be a low level. A time base signal (8Hz) is output from $\overline{\text{BO1}}$ when TBC in the serial data is set to 1. 	
$\overline{\text{IO1}}$ $\overline{\text{IO2}}$	11 14	I/O port	<ul style="list-style-type: none"> Shared function I/O ports The pin function is determined by IOC1 and IOC2 in the serial data. <ul style="list-style-type: none"> When the data value 0: Input port When the data value 1: Output port When specified to function as an input port: <ul style="list-style-type: none"> The input pin state is reported to the controller through the DO pin. When the input state is low: The data will be 0: When the input state is high: The data will be 1: When specified to function as an output port: <ul style="list-style-type: none"> The output state is determined by IO1 and IO2 in the serial data. When the data value is 0: The output state will be the open circuit state. When the data value is 1: The output state will be a low level. These pins are set to input mode after a power on reset. 	

Continued on next page.

LC72121MA

Continued from preceding page.

Pin name	Pin No.	Type	Function	Equivalent circuit
PD	19	Charge pump output	<ul style="list-style-type: none"> • PLL charge pump output • A high level is output when the frequency of the local oscillator signal divided by N is higher than the reference frequency, and a low level is output when that frequency is lower. This pin goes to the highimpedance state when the frequencies match. 	
AIN AOUT	20 21	Low-pass filter amplifier transistor	<ul style="list-style-type: none"> • Connections for the MOS transistor used for the PLL active low-pass filter. 	
VSSa	22	Ground	<ul style="list-style-type: none"> • Ground for the low-pass filter MOS transistor 	
IFIN	13	IF counter	<ul style="list-style-type: none"> • The input frequency range is 0.4 to 15MHz • The signal is passed directly to the IF counter. • The result is output, MSB first, through the DO pin. • Four measurement periods are supported: 4, 8, 32, and 64ms. 	
NC	12 23	NC pin	<ul style="list-style-type: none"> • No connection 	-

LC72121MA

Procedures for Input and Output of Serial Data

This product uses the CCB (Computer Control Bus), which is Ours audio product serial bus format, for data input and output. This product adopts an 8-bit address CCB format.

	I/O mode	Address								Function
		B0	B1	B2	B3	A0	A1	A2	A3	
[1]	IN1(82)	0	0	0	1	0	1	0	0	<ul style="list-style-type: none"> Control data input (serial data input) mode 24 bits of data are input. See the "DI Control Data (serial data input)" section for details on the content of the input data.
[2]	IN2(92)	1	0	0	1	0	1	0	0	<ul style="list-style-type: none"> Control data input (serial data input) mode 24 bits of data are input. See the "DI Control Data (serial data input)" section for details on the content of the input data.
[3]	OUT(A2)	0	1	0	1	0	1	0	0	<ul style="list-style-type: none"> Data output (serial data output) mode The number of bits output is equal to the number of clock cycles. See the "DO output Data (serial data output)" section for details on the content of the output data.

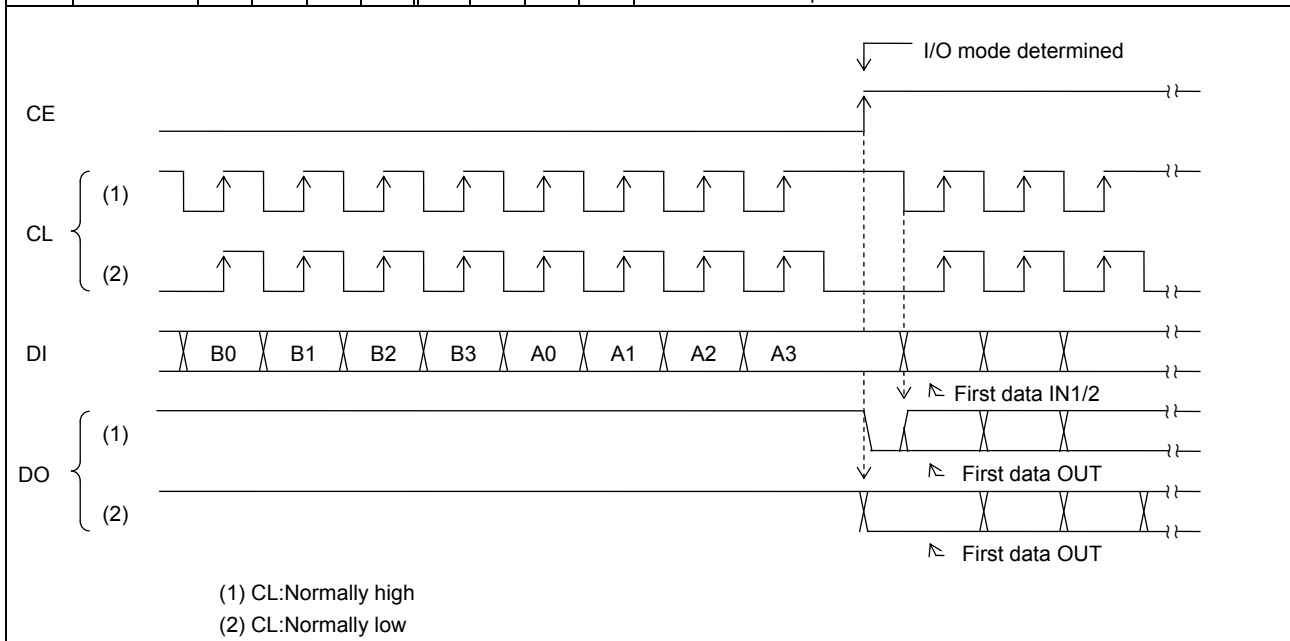

LC72121MA

Structure of the DI Control Data (serial data input)

[1] IN1 mode

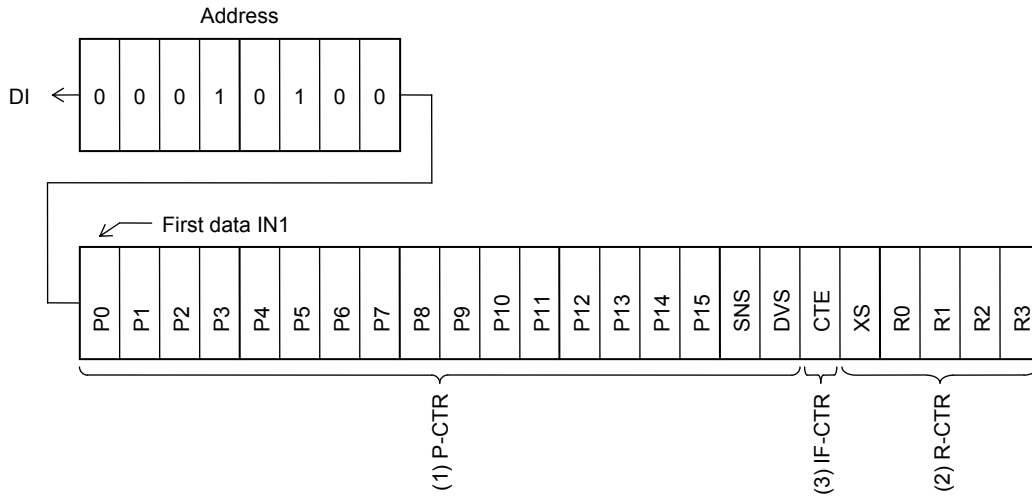

[2] IN2 mode

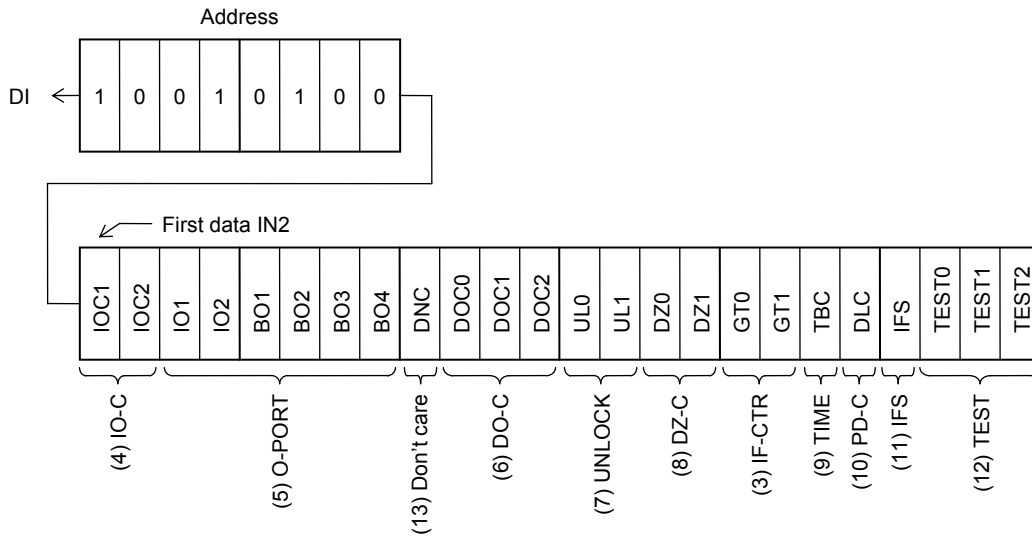

LC72121MA

Control Data

No.	Control block/data	Function	Related data																																																																																					
(1)	Programmable divider data P0 to P15 DVS, SNS	<ul style="list-style-type: none"> Specifies the divisor for the programmable divider. This is a binary value in which P15 is the MSB. The LSB changes depending on DVS and SNS. (* : don't care) <table border="1"> <thead> <tr> <th>DVS</th> <th>SNS</th> <th>LSB</th> <th>Set divisor (N)</th> <th>Actual divisor</th> </tr> </thead> <tbody> <tr> <td>1</td> <td>*</td> <td>P0</td> <td>272 to 65535</td> <td>Twice the set value</td> </tr> <tr> <td>0</td> <td>1</td> <td>P0</td> <td>272 to 65535</td> <td>The set value</td> </tr> <tr> <td>0</td> <td>0</td> <td>P4</td> <td>4 to 4095</td> <td>The set value</td> </tr> </tbody> </table> <ul style="list-style-type: none"> * LSB : When P4 is the LSB, P0 to P3 are ignored. These pins select the signal input to the programmable divider (FMIN or AMIN) and switch the input frequency range. (* : don't care) <table border="1"> <thead> <tr> <th>DVS</th> <th>SNS</th> <th>Input pin</th> <th>Frequency range accepted by the input pin</th> </tr> </thead> <tbody> <tr> <td>1</td> <td>*</td> <td>FMIN</td> <td>10 to 160MHz</td> </tr> <tr> <td>0</td> <td>1</td> <td>AMIN</td> <td>2 to 40MHz</td> </tr> <tr> <td>0</td> <td>0</td> <td>AMIN</td> <td>0.5 to 10MHz</td> </tr> </tbody> </table>	DVS	SNS	LSB	Set divisor (N)	Actual divisor	1	*	P0	272 to 65535	Twice the set value	0	1	P0	272 to 65535	The set value	0	0	P4	4 to 4095	The set value	DVS	SNS	Input pin	Frequency range accepted by the input pin	1	*	FMIN	10 to 160MHz	0	1	AMIN	2 to 40MHz	0	0	AMIN	0.5 to 10MHz																																																		
DVS	SNS	LSB	Set divisor (N)	Actual divisor																																																																																				
1	*	P0	272 to 65535	Twice the set value																																																																																				
0	1	P0	272 to 65535	The set value																																																																																				
0	0	P4	4 to 4095	The set value																																																																																				
DVS	SNS	Input pin	Frequency range accepted by the input pin																																																																																					
1	*	FMIN	10 to 160MHz																																																																																					
0	1	AMIN	2 to 40MHz																																																																																					
0	0	AMIN	0.5 to 10MHz																																																																																					
(2)	Reference divider data R0 to R3 XS	<ul style="list-style-type: none"> Reference frequency selection <table border="1"> <thead> <tr> <th>R3</th> <th>R2</th> <th>R1</th> <th>R0</th> <th>Reference frequency</th> </tr> </thead> <tbody> <tr><td>0</td><td>0</td><td>0</td><td>0</td><td>100 kHz</td></tr> <tr><td>0</td><td>0</td><td>0</td><td>1</td><td>50</td></tr> <tr><td>0</td><td>0</td><td>1</td><td>0</td><td>25</td></tr> <tr><td>0</td><td>0</td><td>1</td><td>1</td><td>25</td></tr> <tr><td>0</td><td>1</td><td>0</td><td>0</td><td>12.5</td></tr> <tr><td>0</td><td>1</td><td>0</td><td>1</td><td>6.25</td></tr> <tr><td>0</td><td>1</td><td>1</td><td>0</td><td>3.125</td></tr> <tr><td>0</td><td>1</td><td>1</td><td>1</td><td>3.125</td></tr> <tr><td>1</td><td>0</td><td>0</td><td>0</td><td>10</td></tr> <tr><td>1</td><td>0</td><td>0</td><td>1</td><td>9</td></tr> <tr><td>1</td><td>0</td><td>1</td><td>0</td><td>5</td></tr> <tr><td>1</td><td>0</td><td>1</td><td>1</td><td>1</td></tr> <tr><td>1</td><td>1</td><td>0</td><td>0</td><td>3</td></tr> <tr><td>1</td><td>1</td><td>0</td><td>1</td><td>15</td></tr> <tr><td>1</td><td>1</td><td>1</td><td>0</td><td>* PLL INHIBIT+X'tal OSC STOP</td></tr> <tr><td>1</td><td>1</td><td>1</td><td>1</td><td>* PLL INHIBIT</td></tr> </tbody> </table> <ul style="list-style-type: none"> * PLL INHIBIT mode In this mode, the programmable divider and the IF counter block are stopped, the FMIN, AMIN, and IFIN pins are pulled down to ground, and the charge pump output goes to the high-impedance state. Crystal oscillator element selection data XS = 0: 4.5MHz XS = 1: 7.2MHz Note that 7.2 MHz is selected after a power on reset. 	R3	R2	R1	R0	Reference frequency	0	0	0	0	100 kHz	0	0	0	1	50	0	0	1	0	25	0	0	1	1	25	0	1	0	0	12.5	0	1	0	1	6.25	0	1	1	0	3.125	0	1	1	1	3.125	1	0	0	0	10	1	0	0	1	9	1	0	1	0	5	1	0	1	1	1	1	1	0	0	3	1	1	0	1	15	1	1	1	0	* PLL INHIBIT+X'tal OSC STOP	1	1	1	1	* PLL INHIBIT	
R3	R2	R1	R0	Reference frequency																																																																																				
0	0	0	0	100 kHz																																																																																				
0	0	0	1	50																																																																																				
0	0	1	0	25																																																																																				
0	0	1	1	25																																																																																				
0	1	0	0	12.5																																																																																				
0	1	0	1	6.25																																																																																				
0	1	1	0	3.125																																																																																				
0	1	1	1	3.125																																																																																				
1	0	0	0	10																																																																																				
1	0	0	1	9																																																																																				
1	0	1	0	5																																																																																				
1	0	1	1	1																																																																																				
1	1	0	0	3																																																																																				
1	1	0	1	15																																																																																				
1	1	1	0	* PLL INHIBIT+X'tal OSC STOP																																																																																				
1	1	1	1	* PLL INHIBIT																																																																																				
(3)	IF counter control data CTE GT0, GT1	<ul style="list-style-type: none"> IF counter measurement start command data CTE = 1 : Starts the counter CTE = 0 : Resets the counter IF counter measurement time. <table border="1"> <thead> <tr> <th>GT1</th> <th>GT0</th> <th>Measurement time</th> <th>Wait time</th> </tr> </thead> <tbody> <tr> <td>0</td> <td>0</td> <td>4 ms</td> <td>3 to 4 ms</td> </tr> <tr> <td>0</td> <td>1</td> <td>8</td> <td>3 to 4</td> </tr> <tr> <td>1</td> <td>0</td> <td>32</td> <td>7 to 8</td> </tr> <tr> <td>1</td> <td>1</td> <td>64</td> <td>7 to 8</td> </tr> </tbody> </table>	GT1	GT0	Measurement time	Wait time	0	0	4 ms	3 to 4 ms	0	1	8	3 to 4	1	0	32	7 to 8	1	1	64	7 to 8	IFS																																																																	
GT1	GT0	Measurement time	Wait time																																																																																					
0	0	4 ms	3 to 4 ms																																																																																					
0	1	8	3 to 4																																																																																					
1	0	32	7 to 8																																																																																					
1	1	64	7 to 8																																																																																					
(4)	I/O port setup data IOC1,IOC2	<ul style="list-style-type: none"> Specifies input or output for the shared function I/O pins ($\overline{IO1}$ and $\overline{IO2}$). Data = 0: Input port Data = 1: Output port 																																																																																						
(5)	Output port data BO1 to BO4 IO1,IO2	<ul style="list-style-type: none"> Determines the output state of the $\overline{BO1}$ through $\overline{BO4}$, $\overline{IO1}$, and $\overline{IO2}$ output ports. Data = 0: Open Data = 1: Low level The data is reset to 0, setting the pins to the open state, after a power on reset. 	IOC1 IOC2																																																																																					

Continued on next page.

LC72121MA

Continued from preceding page.

No.	Control block/data	Function	Related data																																				
(6)	DO pin control data DOC0 DOC1 DOC2	<ul style="list-style-type: none"> Determines the DO pin output. <table border="1" style="margin-left: 20px; border-collapse: collapse; text-align: center;"> <thead> <tr> <th>DOC2</th> <th>DOC1</th> <th>DOC0</th> <th>DO pin state</th> </tr> </thead> <tbody> <tr> <td>0</td> <td>0</td> <td>0</td> <td>Open</td> </tr> <tr> <td>0</td> <td>0</td> <td>1</td> <td>Low when the PLL is unlocked</td> </tr> <tr> <td>0</td> <td>1</td> <td>0</td> <td>end-UC *1</td> </tr> <tr> <td>0</td> <td>1</td> <td>1</td> <td>Open</td> </tr> <tr> <td>1</td> <td>0</td> <td>0</td> <td>Open</td> </tr> <tr> <td>1</td> <td>0</td> <td>1</td> <td>The $\overline{IO1}$ pin state *2</td> </tr> <tr> <td>1</td> <td>1</td> <td>0</td> <td>The $\overline{IO2}$ pin state *2</td> </tr> <tr> <td>1</td> <td>1</td> <td>1</td> <td>Open</td> </tr> </tbody> </table> <p>The open state is selected after a power on reset.</p> <p>*1. end-UC: IF counter measurement end check</p> <div style="margin-left: 20px;"> <p style="text-align: center;">(1) Count start (2) Count end CE:high</p> </div> <p>(1) When end-UC is selected and an IF count is started (by switching CTE from 0 to 1), the DO pin automatically goes to the open state.</p> <p>(2) When the IF counter measurement period completes, the DO pin goes to the low level, allowing applications to test for the completion of the count period.</p> <p>(3) The DO pin is set to the open state by performing a serial data input or output operation (when the CE pin is set high).</p> <p>*2. The DO pin will go to the open state if the corresponding IO pin is set up to be an output port.</p> <p>Note) During the data input period (the period that CE is high in IN1 or IN2 mode), the DO pin goes to the open state regardless of the DO pin control data (DOC0 to DOC2). During the data output period (the period that CE is high in OUT mode) the DO pin state reflects the internal DO serial data in synchronization with the CL clock, regardless of the DO pin control data (DOC0 to DOC2).</p>	DOC2	DOC1	DOC0	DO pin state	0	0	0	Open	0	0	1	Low when the PLL is unlocked	0	1	0	end-UC *1	0	1	1	Open	1	0	0	Open	1	0	1	The $\overline{IO1}$ pin state *2	1	1	0	The $\overline{IO2}$ pin state *2	1	1	1	Open	UL0, UL1 CTE IOC1 IOC2
DOC2	DOC1	DOC0	DO pin state																																				
0	0	0	Open																																				
0	0	1	Low when the PLL is unlocked																																				
0	1	0	end-UC *1																																				
0	1	1	Open																																				
1	0	0	Open																																				
1	0	1	The $\overline{IO1}$ pin state *2																																				
1	1	0	The $\overline{IO2}$ pin state *2																																				
1	1	1	Open																																				
(7)	Unlocked state detection data UL0, UL1	<ul style="list-style-type: none"> Selects the width of the phase error (ϕE) detected for PLL lock state discrimination. The state is taken to be unlocked if a phase error in excess of the detection width occurs. <table border="1" style="margin-left: 20px; border-collapse: collapse; text-align: center;"> <thead> <tr> <th>UL1</th> <th>UL0</th> <th>ϕE detection width</th> <th>Detection output</th> </tr> </thead> <tbody> <tr> <td>0</td> <td>0</td> <td>Stop</td> <td>Open</td> </tr> <tr> <td>0</td> <td>1</td> <td>0</td> <td>ϕE is output directly</td> </tr> <tr> <td>1</td> <td>0</td> <td>$\pm 0.55\mu s$</td> <td>ϕE is extended by 1 to 2ms</td> </tr> <tr> <td>1</td> <td>1</td> <td>$\pm 1.11\mu s$</td> <td>↑</td> </tr> </tbody> </table> <p>* When the PLL is unlocked, the DO pin goes low and UL in the serial data output is set to 0.</p>	UL1	UL0	ϕE detection width	Detection output	0	0	Stop	Open	0	1	0	ϕE is output directly	1	0	$\pm 0.55\mu s$	ϕE is extended by 1 to 2ms	1	1	$\pm 1.11\mu s$	↑	DOC0 DOC1 DOC2																
UL1	UL0	ϕE detection width	Detection output																																				
0	0	Stop	Open																																				
0	1	0	ϕE is output directly																																				
1	0	$\pm 0.55\mu s$	ϕE is extended by 1 to 2ms																																				
1	1	$\pm 1.11\mu s$	↑																																				
(8)	Phase comparator control data DZ0, DZ1	<ul style="list-style-type: none"> Controls the phase comparator dead zone <table border="1" style="margin-left: 20px; border-collapse: collapse; text-align: center;"> <thead> <tr> <th>DZ1</th> <th>DZ0</th> <th>Dead zone mode</th> </tr> </thead> <tbody> <tr> <td>0</td> <td>0</td> <td>DZA</td> </tr> <tr> <td>0</td> <td>1</td> <td>DZB</td> </tr> <tr> <td>1</td> <td>0</td> <td>DZC</td> </tr> <tr> <td>1</td> <td>1</td> <td>DZD</td> </tr> </tbody> </table> <p>Dead zone width: DZA < DZB < DZC < DZD</p>	DZ1	DZ0	Dead zone mode	0	0	DZA	0	1	DZB	1	0	DZC	1	1	DZD																						
DZ1	DZ0	Dead zone mode																																					
0	0	DZA																																					
0	1	DZB																																					
1	0	DZC																																					
1	1	DZD																																					
(9)	Clock time base TBC	<ul style="list-style-type: none"> Setting the TBC bit to 1 causes an 8-Hz clock time base signal with a 40% duty to be output from the $\overline{BO1}$ pin. (The BO1 data will be ignored.) 	BO1																																				
(10)	Charge pump control data DLC	<ul style="list-style-type: none"> Forcibly controls the charge pump output. <table border="1" style="margin-left: 20px; border-collapse: collapse; text-align: center;"> <thead> <tr> <th>DLC</th> <th>Charge pump output</th> </tr> </thead> <tbody> <tr> <td>0</td> <td>Normal operation</td> </tr> <tr> <td>1</td> <td>Forced Low</td> </tr> </tbody> </table> <p>* If the circuit deadlocks due to the VCO control voltage (V_{tune}) being 0 and the VCO being stopped, applications can get out of the deadlocked state by setting the charge pump output to low and setting V_{tune} to V_{CC}. (Deadlock clear circuit)</p>	DLC	Charge pump output	0	Normal operation	1	Forced Low																															
DLC	Charge pump output																																						
0	Normal operation																																						
1	Forced Low																																						
(11)	IF counter control data IFS	<ul style="list-style-type: none"> This data is normally set to 1. Setting this data to 0 sets the circuit to reduced input sensitivity mode, in which the sensitivity is reduced by about 10 to 30mV rms. <p>* See the "IF Counter Operation" section for details.</p>																																					
(12)	Test data TEST0 to 2	<ul style="list-style-type: none"> Test data <table style="margin-left: 20px;"> <tr> <td>TEST0</td> <td rowspan="3" style="font-size: 2em; vertical-align: middle;">}</td> <td rowspan="3" style="vertical-align: middle;">All these bits must be set to 0.</td> </tr> <tr> <td>TEST1</td> </tr> <tr> <td>TEST2</td> </tr> </table> <p>All these bits are set to 0 after a power on reset.</p>	TEST0	}	All these bits must be set to 0.	TEST1	TEST2																																
TEST0	}	All these bits must be set to 0.																																					
TEST1																																							
TEST2																																							
(13)	DNC	<ul style="list-style-type: none"> This bit must be set to 0. 																																					

LC72121MA

Structure of the DO Output Data (serial data output)

[3] OUT mode

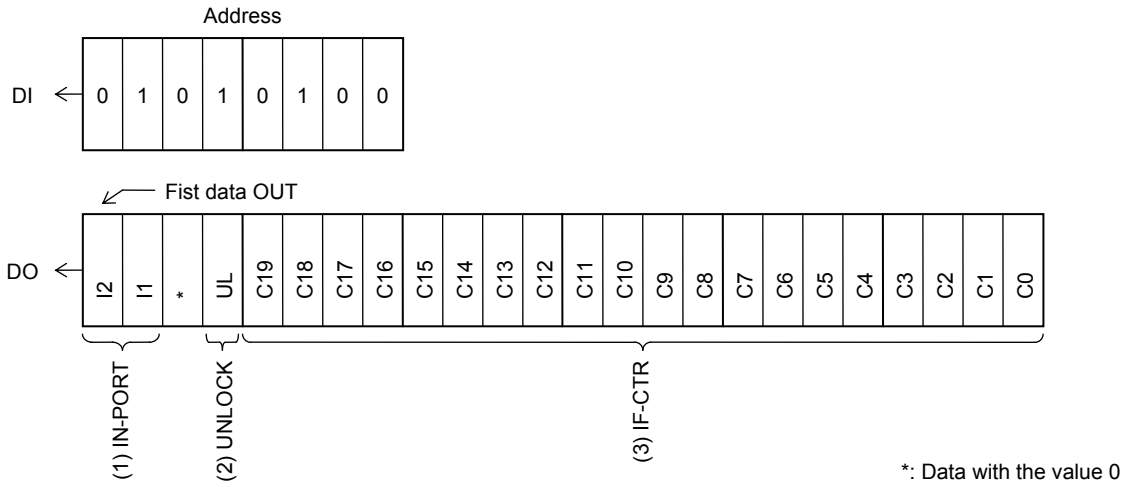

Control Data Functions

No.	Control block/data	Function	Related data
(1)	I/O port data I2, I1	<ul style="list-style-type: none"> Data latched from the I/O port $\overline{IO1}$ or $\overline{IO2}$ pin states. These bits reflect the pin states regardless of the I/O port mode (input or output). The data is latched at the point the circuit enters data output mode (OUT mode). <p> $I1 \leftarrow$ The $\overline{IO1}$ pin state High : 1 $I2 \leftarrow$ The $\overline{IO2}$ pin state Low : 0 </p>	IOC1 IOC2
(2)	PLL unlocked state data UL	<ul style="list-style-type: none"> Indicates the state of the unlocked state detection circuit. <p> $UL \leftarrow 0$: When the PLL is unlocked. $UL \leftarrow 1$: When the PLL is locked or in the detection disabled mode. </p>	UL0 UL1
(3)	IF counter binary counter C19 to C0	<ul style="list-style-type: none"> Indicates the value of the IF counter (20-bit binary counter). <p> $C19 \leftarrow$ MSB of the binary counter $C0 \leftarrow$ LSB of the binary counter </p>	CTE GT0 GT1

LC72121MA

1. Serial Data Input (IN1/IN2) $t_{SU}, t_{HD}, t_{EL}, t_{ES}, t_{EH} \geq 0.75\mu s$ $t_{LC} < 0.75\mu s$

(1) CL: Normally high

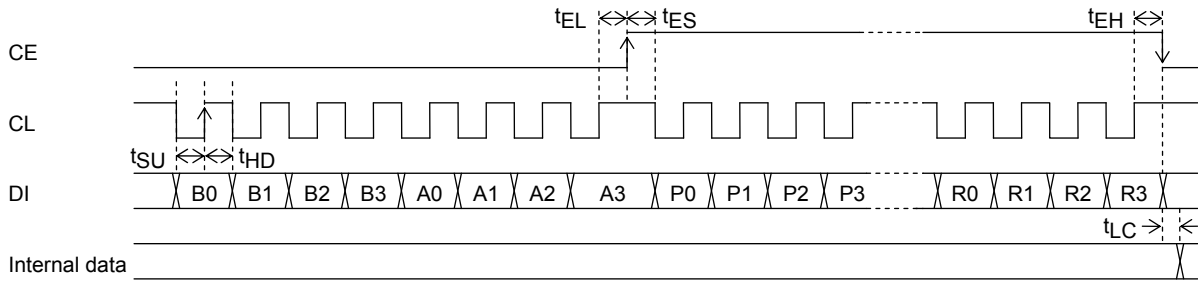

(2) CL: Normally low

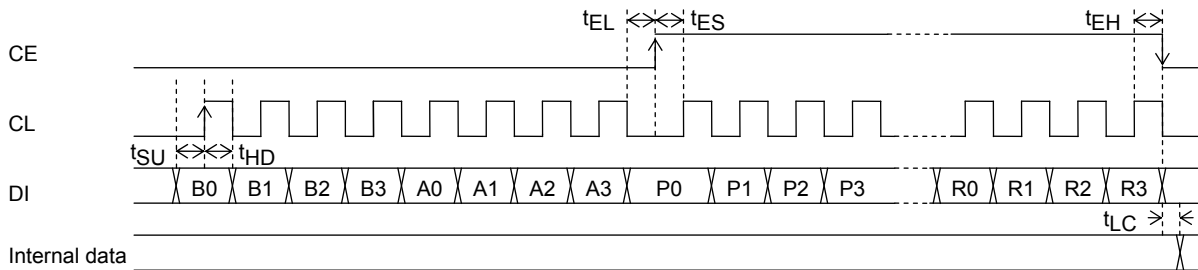

2. Serial Data Output (Out) $t_{SU}, t_{HD}, t_{EL}, t_{ES}, t_{EH} \geq 0.75\mu s$ $t_{DC}, t_{DH} < 0.35\mu s$

(1) CL: Normally high

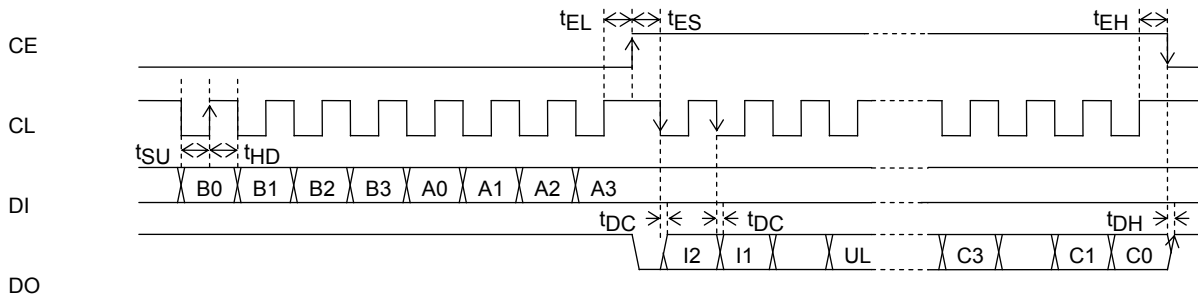

(2) CL: Normally low

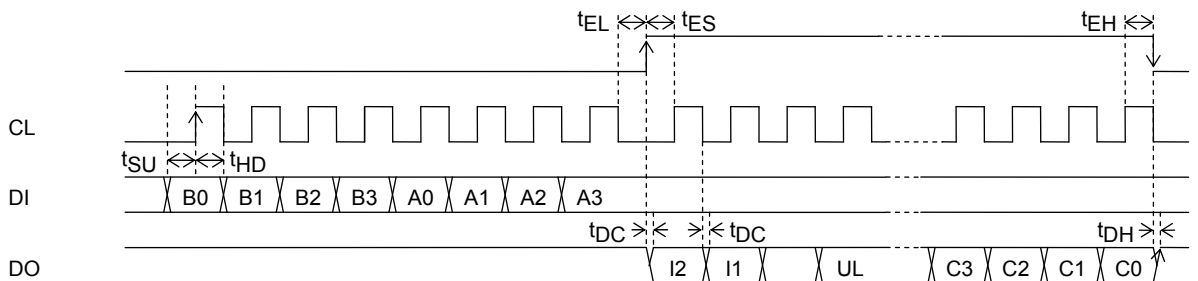

Note: The data conversion times (t_{DC} and t_{DH}) depend on the value of the pull-up resistor and the printed circuit board capacitance since the DO pin is an n-channel open-drain circuit.

LC72121MA

Serial Data Timing

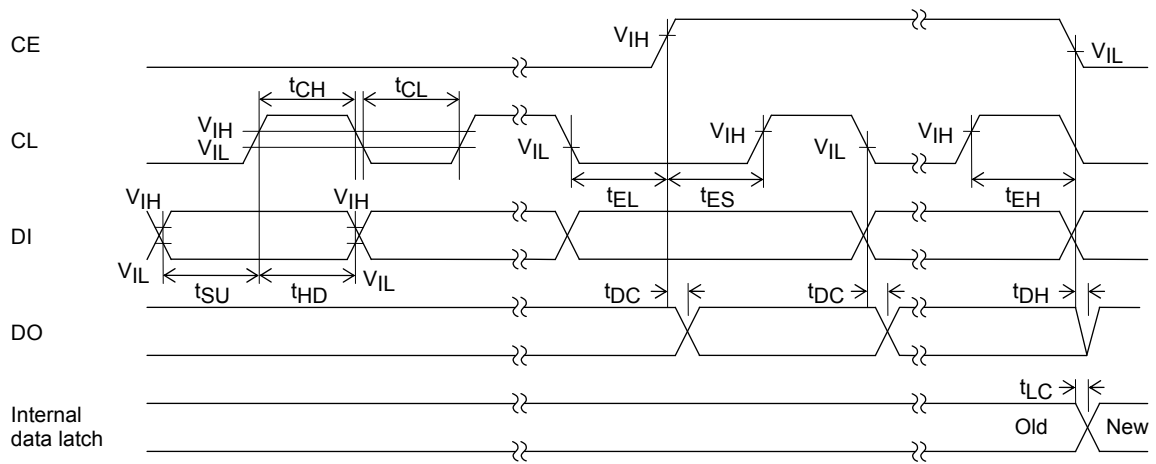

When CL is Stopped at the Low Level

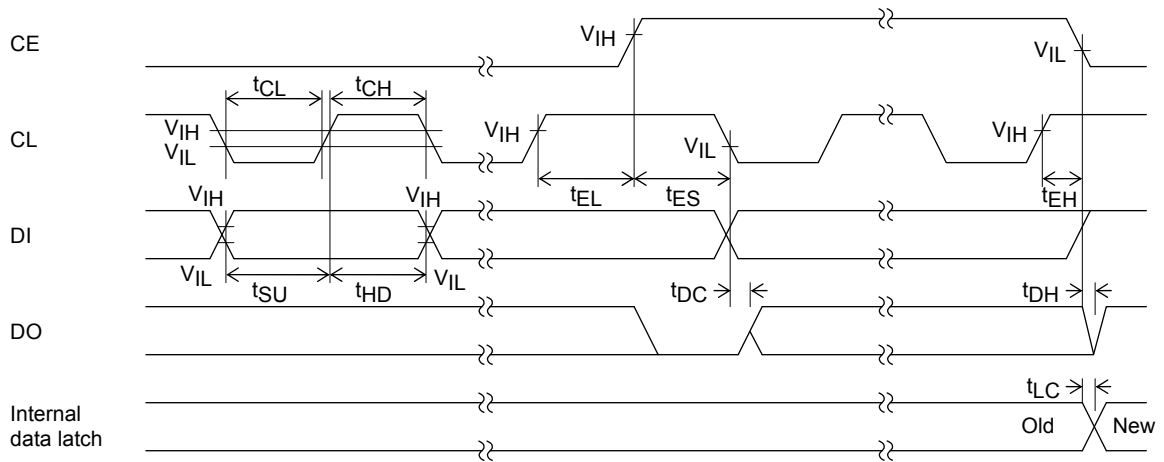

When CL is Stopped at the High Level

LC72121MA

Structure of the Programmable Divider

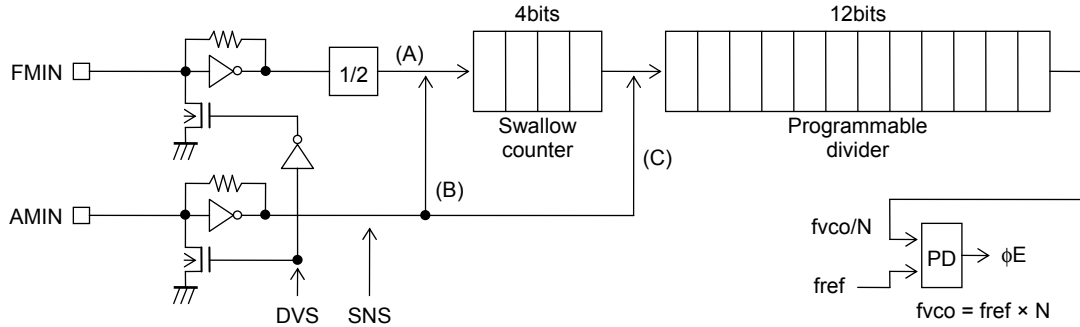

	DVS	SNS	Input pin	Set divisor	Actual divisor	Input frequency range
(A)	1	*	FMIN	272 to 65535	Twice the set value	10 to 160MHz
(B)	0	1	AMIN	272 to 65535	The set value	2 to 40MHz
(C)	0	0	AMIN	4 to 4095	The set value	0.5 to 10MHz

*: Don't care

Sample Programmable Divider Divisor Calculations

- (1) For FM with a step size of 50kHz (DVS = 1, SNS = *: FMIN selected)

FM RF = 90.0MHz (IF +10.7MHz)

FM VCO = 100.7MHz

PLL fref = 25kHz (R0 to R1 = 1, R2 to R3 = 0)

$100.7\text{MHz (FM VCO)} \div 25\text{kHz (fref)} \div 2 \text{ (for the FMIN 1/2 prescaler)} = 2014 \rightarrow 07DE \text{ (hexadecimal)}$

E				D				7				0				SNS	DVS	CTE	XS	R0	R1	R2	R3
0	1	1	1	1	0	1	1	1	1	1	0	0	0	0	0	*	1			1	1	0	0
P0	P1	P2	P3	P4	P5	P6	P7	P8	P9	P10	P11	P12	P13	P14	P15	SNS	DVS	CTE	XS	R0	R1	R2	R3

- (2) For SW with a step size of 5kHz (DVS = 0, SNS = 1: AMIN high-speed operation selected)

SW RF = 21.75 MHz (IF +450kHz)

SW VCO = 22.20MHz

PLL fref = 5kHz (R0 = R2 = 0, R1 = R3 = 1)

$22.2\text{MHz (SW VCO)} \div 5\text{kHz (fref)} = 4440 \rightarrow 1158 \text{ (hexadecimal)}$

8				5				1		1		SNS	DVS	CTE	XS	R0	R1	R2	R3				
0	0	0	1	1	0	1	0	1	0	0	0	1	0			0	1	0	1				
P0	P1	P2	P3	P4	P5	P6	P7	P8	P9	P10	P11	P12	P13	P14	P15	SNS	DVS	CTE	XS	R0	R1	R2	R3

- (3) For MW with a step size of 9kHz (DVS = 0, SNS = 0: AMIN low-speed operation selected)

MW RF = 1008kHz (IF +450kHz)

WM VCO = 1458kHz

PLL fref = 9kHz (R0 = R3 = 1, R1 = R2 = 0)

$1458 \text{ (MW VCO)} \div 9\text{kHz (fref)} = 162 \rightarrow 0A2 \text{ (hexadecimal)}$

*	*	*	*	2				A				0				SNS	DVS	CTE	XS	R0	R1	R2	R3
*	*	*	*	0	1	0	0	0	1	0	1	0	0	0	0	0	0			1	0	0	1
P0	P1	P2	P3	P4	P5	P6	P7	P8	P9	P10	P11	P12	P13	P14	P15	SNS	DVS	CTE	XS	R0	R1	R2	R3

LC72121MA

Structure of the IF Counter

The LC72121MA IF counter is a 20-bit binary counter, and takes the IF signal from the IFIN pin as its input. The result of the count can be read out serially, MSB first, from the DO pin.

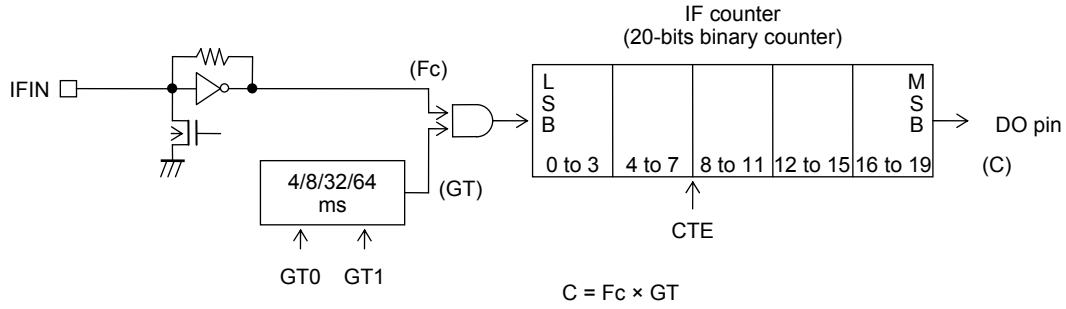

GT1	GT0	Measurement time	
		Measurement time (GT)	Wait time (t _{WU})
0	0	4 ms	3 to 4 ms
0	1	8	3 to 4
1	0	32	7 to 8
1	1	64	7 to 8

The IF frequency (Fc) is measured by determining how many pulses were input to the IF counter in the stipulated measurement time, GT.

$$F_c = \frac{C}{GT} \quad (C = F_c \times GT) \quad C: \text{Counted value (the number of pulses)}$$

IF Counter Frequency Measurement Examples

- (1) When the measurement time (GT) is 32ms and the counted value (C) is 53980 (hexadecimal) or 342,400 (decimal).

$$\text{IF frequency (Fc)} = 342400 \div 32\text{ms} = 10.7\text{MHz}$$

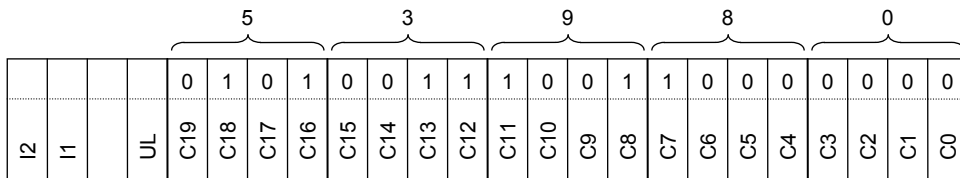

- (2) When the measurement time (GT) is 8ms and the counted value (C) is E10 (hexadecimal) or 3600 (decimal).

$$\text{IF frequency (FC)} = 3600 \div 8\text{ms} = 450\text{kHz}$$

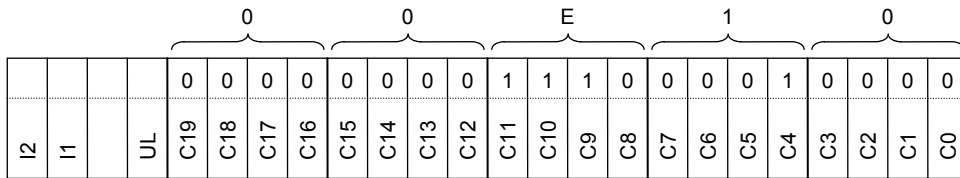

IF Counter Operation

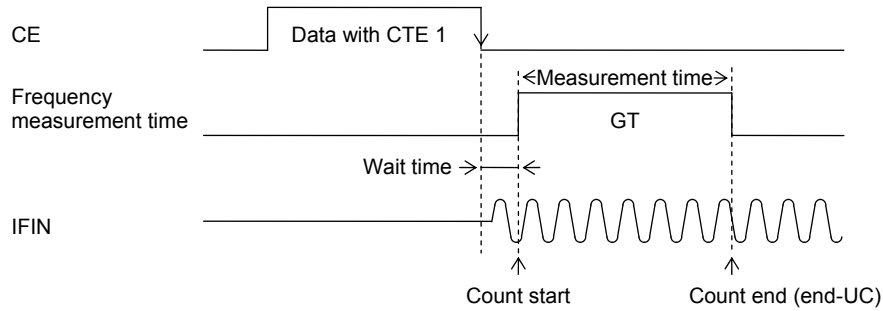

Applications must first, before starting an IF count operation reset the IF counter by setting CTE in the serial data to 0. The IF counter operation is started setting CTE in the serial data from 0 to 1. Although the serial data is latched by dropping the CE pin from high to low, the IF signal input to the IFIN pin must be provided within the wait time from the point CE goes low. Next, the readout of the IF counter after measurement is complete must be performed while CTE is still 1, since the counter will be reset if CTE is set to 0.

Note: If IF counting is used, applications must determine whether or not the IF IC SD (station detect) signal is present in the microcontroller software, and perform the IF count only if that signal is asserted. This is because auto-search techniques that use IF counting only are subject to incorrect stopping at points where there is no station due to IF buffer leakage.

Note that the LC72121MA input sensitivity can be controlled with the IFS bit in the serial data. Reduced sensitivity mode (IFS = 0) must be selected when this IC is used in conjunction with an IF IC that does not provide an SD output and auto-search is implemented using only IF counting.

IFIN Minimum Sensitivity Standard

IFS data	Input frequency : f [MHz]		
	$0.4 \leq f < 0.5$	$0.5 \leq f < 8$	$8 \leq f \leq 15$
1 (Normal mode)	40mVrms (0.1 to 3mVrms)	40mVrms	40mVrms(1 to 15mVrms)
0 (Degraded sensitivity mode)	70mVrms(5 to 10mVrms)	70mVrms	70mVrms(30 to 40mVrms)

Note: Values in parentheses are actual performance values that are provided for reference purposes.

Unlocked State Detection

1. Unlocked state detection timing

Unlocked state detection is performed during the reference frequency (f_{ref}) period (interval). This means that a period at least as long as the period of the reference frequency is required to recognize the locked/unlocked state. However, applications must wait at least twice the period of the reference frequency immediately after changing the divisor (N) before checking the locked/unlocked state.

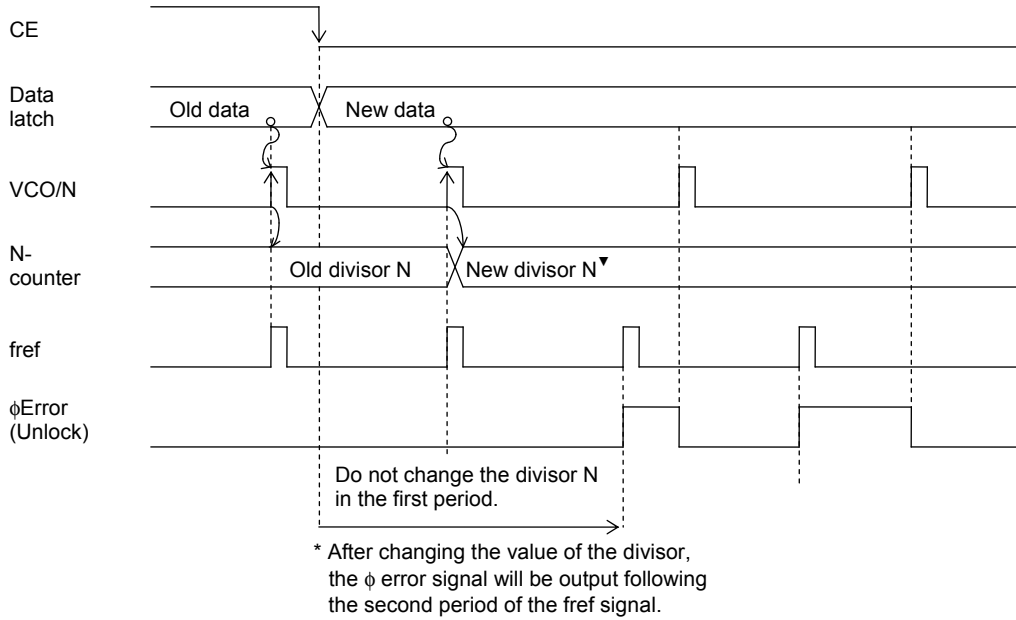

Figure 1 Unlocked State Detection Timing

For example, if f_{ref} is 1kHz (a period of 1ms) applications must wait at least 2 ms after the divisor N is changed before performing a locked/unlocked check.

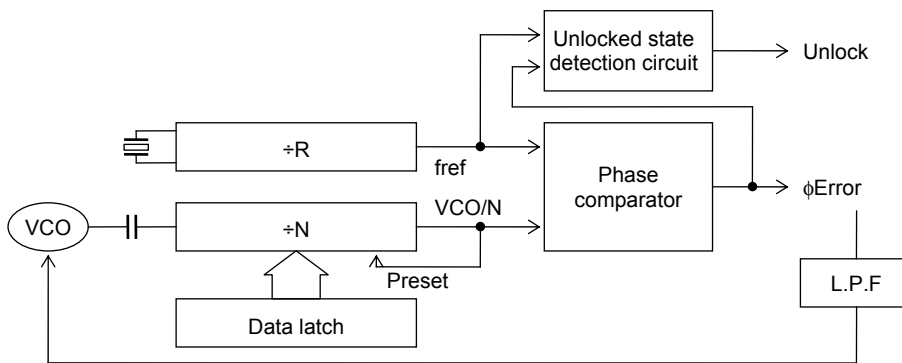

Figure 2 Circuit Structure

2. Combining with Software

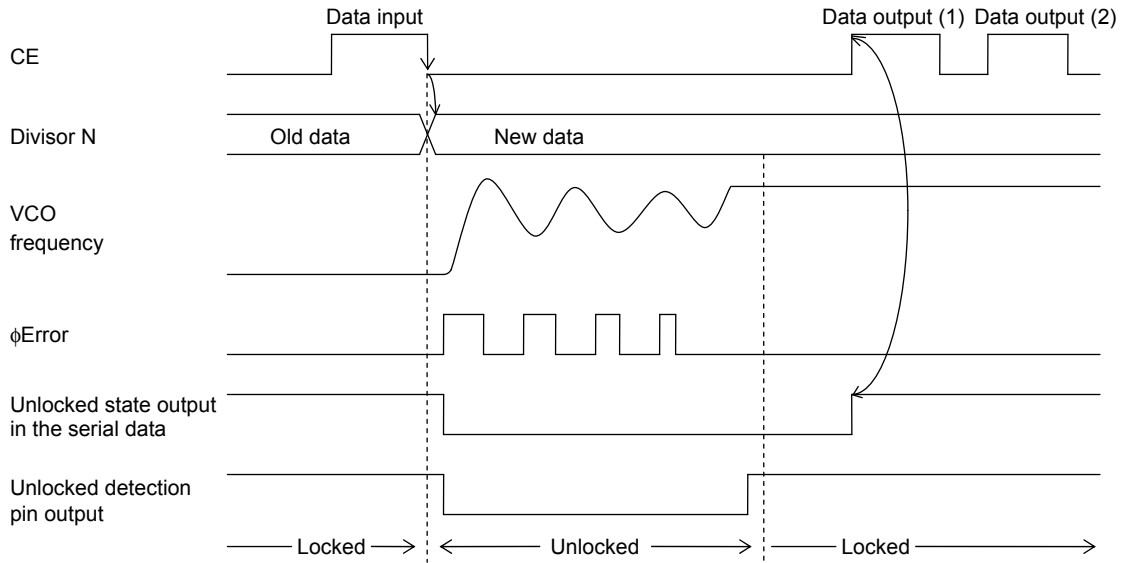
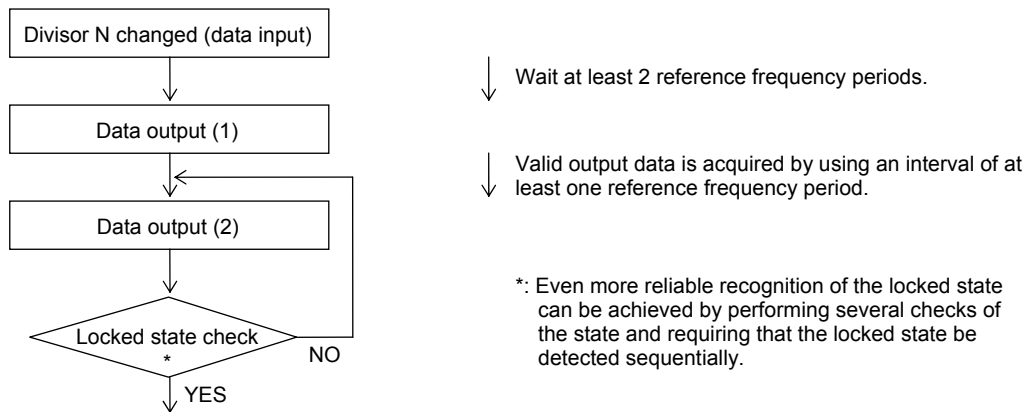

Figure 3 Combining with Software

3. Outputting the unlocked state data in the serial data

At the point of data output 1 in figure 3, the unlocked state data will indicate the unlocked state, since the VCO frequency is not stable (locked) yet. In cases such as this, the application should wait at least one whole period and then check again whether or not the frequency has stabilized with the data output 2 operation in the figure. Applications can implement even more reliable recognition of the locked state by performing several more checks of the state and requiring that the locked state be detected sequentially.

<Flowchart for Lock Detection>



4. Directly outputting the unlocked state to the DO pin

Since the unlocked state (high level when locked, low when unlocked) is output from the DO pin, applications can check for the locked state by waiting at least two reference frequency periods after changing the divisor N. However, in this case also, even more reliable recognition of the locked state can be achieved by performing several checks of the state and requiring that the locked state be detected sequentially.

LC72121MA

Clock Time Base Usage Notes

When using the clock time base output function, the output pin ($\overline{\text{BO1}}$) pull-up resistor must have a value of over $100\text{k}\Omega$. The use of a Schmitt input in the microcontroller that accepts this signal is recommended to reduce chattering. This is to prevent degradation of the VCO C/N characteristics when combining with a loop filter that uses the internal transistor provided to form a low-pass filter. Although the ground for the clock time base output pin (V_{SSd}) and the ground for the transistor (V_{SSa}) are isolated internally on the chip, applications must take care to avoid ground loops and minimize current fluctuations in the time base pin to prevent degradation of the low-pass filter characteristics.

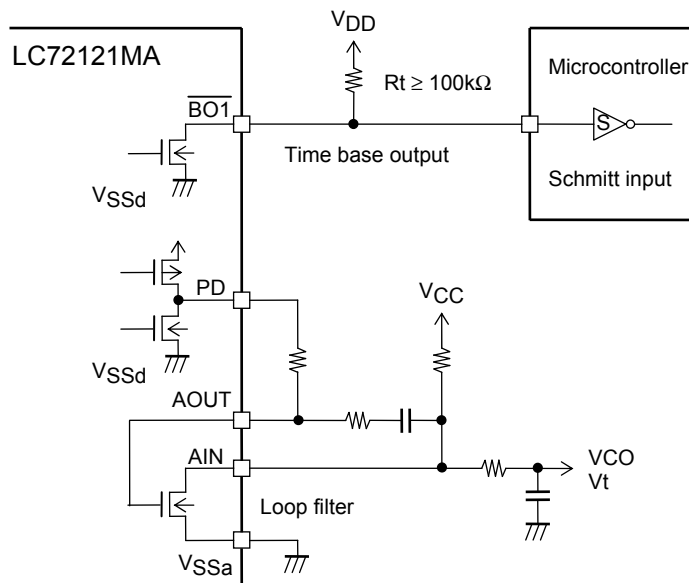

Other Items

(1) Notes on the phase comparator dead zone

DZ1	DZ0	Dead zone mode	Charge pump	Dead zone
0	0	DZA	ON/ON	--0s
0	1	DZB	ON/ON	-0s
1	0	DZC	OFF/OFF	+0s
1	1	DZD	OFF/OFF	++0s

When the charge pump is used with one of the ON/ON modes, correction pulses are generated from the charge pump even if the PLL is locked. As a result, it is easy for the loop to become unstable, and special care is required in application design. The following problems can occur if an ON/ON mode is used.

- (1) Sidebands may be created by reference frequency leakage.
- (2) Sidebands may be created by low-frequency leakage due to the correction pulse envelope.

Although the loop is more stable when a dead zone is present (i.e. when an OFF/OFF mode is used), a dead zone makes it more difficult to achieve excellent C/N characteristics. On the other hand, while it is easy to achieve good C/N characteristics when there is no dead zone, achieving good loop stability is difficult. Accordingly, the DZA and DZB settings, in which there is no dead zone, can be effective in situations where a signal-to-noise ratio of 90 to 100dB or higher is required in FM reception, or where it is desirable to increase the pilot margin in AM stereo reception.

However, if such a high signal-to-noise ratio is not required for FM reception, if an adequate pilot margin can be acquired in AM stereo reception, or if AM stereo is not required, then either DZC or DZD, in which there is a dead zone, should be chosen.

Dead Zone

As shown in figure 1, the phase comparator compares a reference frequency (f_r) with f_p . As shown in figure 2, the phase comparator's characteristics consist of an output voltage (V) that is proportional to the phase difference ϕ . However, due to internal circuit delay and other factors, an actual circuit has a region (the dead zone, B) where the circuit cannot actually compare the phases. To implement a receiver with a high S/N ratio, it is desirable that this region be as small as possible. However, it is often desirable to have the dead zone be slightly wider in popularly-priced models. This is because in certain cases, such as when there is a strong RF input, popularly-priced models can suffer from mixer to VCO RF leakage that modulates the VCO. When the dead zone is small, the circuit outputs signals to correct this modulation and this output further modulates the VCO. This further modulation may then generate beats and the RF signal.

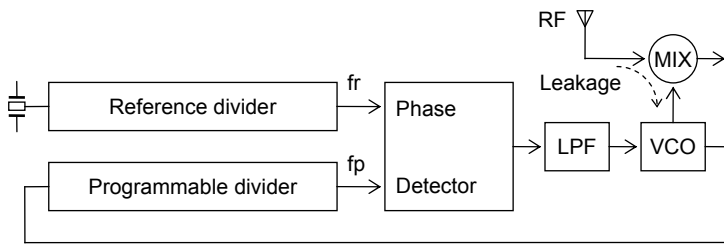

Figure 1

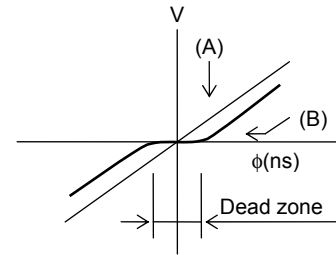

Figure 2

(2) Notes on the FMIN, AMIN, and IFIN pins

Coupling capacitors should be placed as close to their pin as possible. A capacitance of about 100pF is desirable for these capacitors. In particular, if the IFIN pin coupling capacitor is not held under 1000pF, the time to reach the bias level may become excessive and incorrect counts may result due to the relationship with the wait time.

(3) Notes on IF counting → Use the SD signal in conjunction with IF counting

When counting the IF frequency, the microcontroller must determine the presence or absence of the IF IC SD (station detect) signal and turn on the IF counter buffer output and execute the IF count only if there is an SD signal. Autosearch techniques that only use the IF counter are subject to incorrect stopping at points where there is no station due to IF buffer leakage.

(4) DO pin usage

The DO pin can be used for IF counter count completion checking and as an unlock detection output in addition to its use in data output mode. It is also possible to have the DO pin reflect the state of an input pin to input that state to the microcontroller.

(5) Power supply pins

Capacitors must be inserted between the power supply V_{DD} and V_{SS} pins for noise exclusion. These capacitors must be placed as close as possible to the V_{DD} and V_{SS} pins.

(6) VCO setup

Applications must be designed so that the VCO (local oscillator) does not stop, even if the control voltage (V_{tune}) goes to 0V. If it is possible for the oscillator to stop, the application must use the control data (DLC) to temporarily force V_{tune} to V_{CC} to prevent deadlock from occurring. (Deadlock clear circuit)

LC72121MA

(7) Front end connection example

Since this product is designed with the relatively high resistance of 200kΩ for the pulldown (on) resistors built in to the FMIN and AMIN pins, a common AM/FM local oscillator buffer can be used as shown in the following circuit.

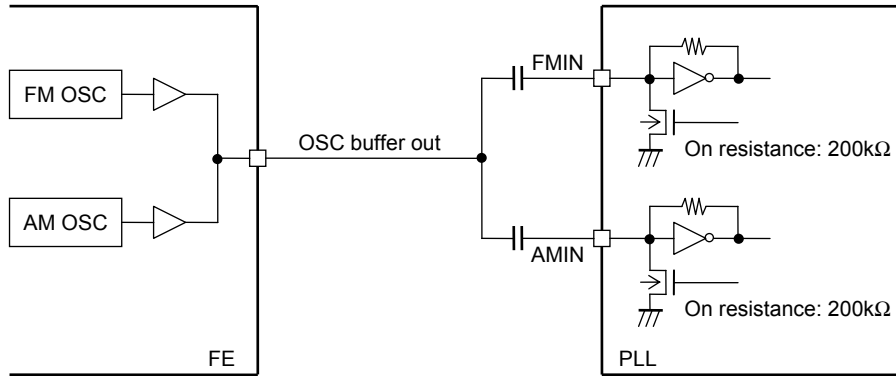

(8) PD pin

Note that the charge pump output voltage is reduced when this IC, which is a 3-V system, is used to replace the LC72131K/KMA, which is a 5-V system. This means that since the loop gain is reduced, the loop filter constants, the lock time (SD wait time), and other related parameters must be reevaluated in the end product design.

Pin States after a Power on Reset

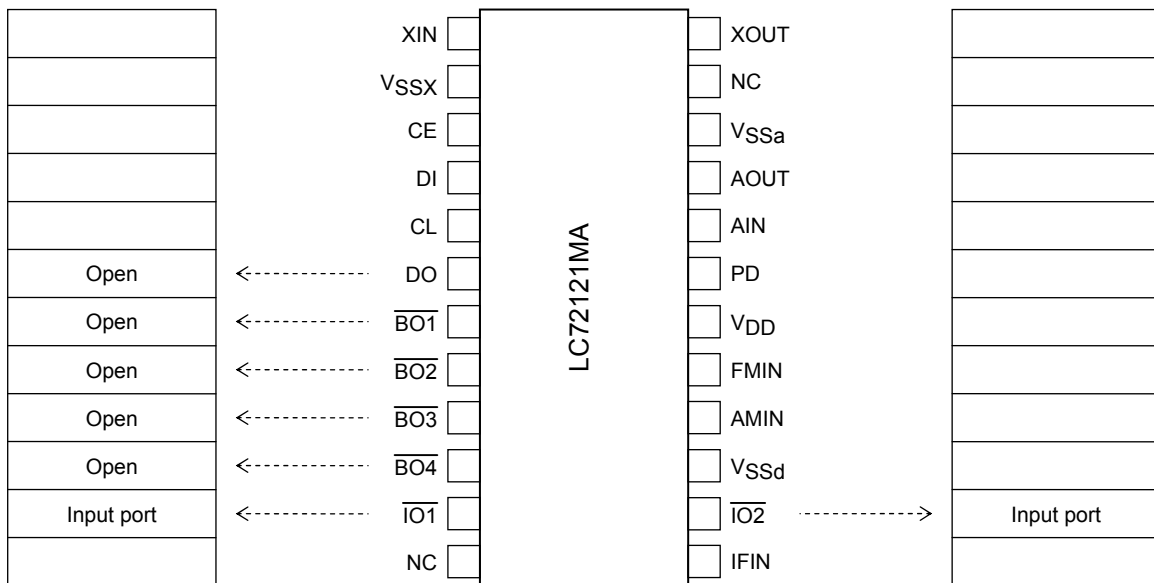

LC72121MA

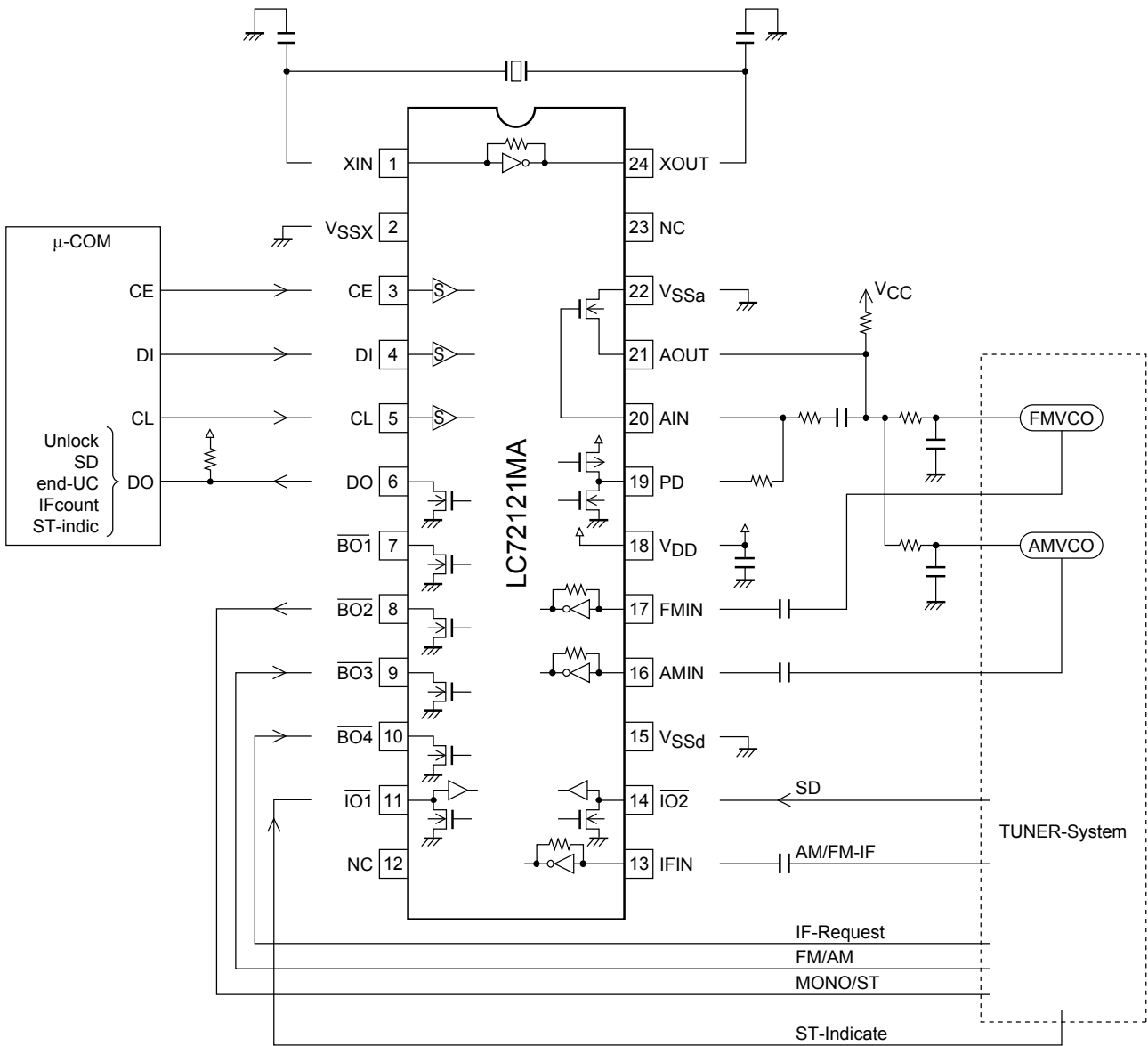

Sample Applications Circuit



ON Semiconductor and the ON logo are registered trademarks of Semiconductor Components Industries, LLC (SCILLC). SCILLC owns the rights to a number of patents, trademarks, copyrights, trade secrets, and other intellectual property. A listing of SCILLC's product/patent coverage may be accessed at www.onsemi.com/site/pdf/Patent-Marking.pdf. SCILLC reserves the right to make changes without further notice to any products herein. SCILLC makes no warranty, representation or guarantee regarding the suitability of its products for any particular purpose, nor does SCILLC assume any liability arising out of the application or use of any product or circuit, and specifically disclaims any and all liability, including without limitation special, consequential or incidental damages. "Typical" parameters which may be provided in SCILLC data sheets and/or specifications can and do vary in different applications and actual performance may vary over time. All operating parameters, including "Typicals" must be validated for each customer application by customer's technical experts. SCILLC does not convey any license under its patent rights nor the rights of others. SCILLC products are not designed, intended, or authorized for use as components in systems intended for surgical implant into the body, or other applications intended to support or sustain life, or for any other application in which the failure of the SCILLC product could create a situation where personal injury or death may occur. Should Buyer purchase or use SCILLC products for any such unintended or unauthorized application, Buyer shall indemnify and hold SCILLC and its officers, employees, subsidiaries, affiliates, and distributors harmless against all claims, costs, damages, and expenses, and reasonable attorney fees arising out of, directly or indirectly, any claim of personal injury or death associated with such unintended or unauthorized use, even if such claim alleges that SCILLC was negligent regarding the design or manufacture of the part. SCILLC is an Equal Opportunity/Affirmative Action Employer. This literature is subject to all applicable copyright laws and is not for resale in any manner.

Looking for pricing, stock, or lifecycle information?

Click below to explore more details on WIN SOURCE:

-  [View LC72121MA-AH on WIN SOURCE](#)
-  [ON Semiconductor](#) Information

Optimize Your Supply Chain with WIN SOURCE Solutions

-  Global Sourcing Solution
-  Obsolete Management
-  Cost Control Management
-  Shortage Management
-  Alternative Solution
-  Excess Inventory Management