



**THE DATASHEET OF
LC05-6.TBT**



PROTECTION PRODUCTS

Description

The LC05-6 has been specifically designed to protect sensitive components which are connected to high-speed telecommunications lines from over voltages caused by lightning, electrostatic discharge (ESD), and electrical fast transients (EFT).

The device is in a JEDEC SO-16 NB package. It is designed to provide metallic surge protection for two tip & ring line pairs. The low capacitance topology means signal integrity is preserved on high-speed lines. The high surge capability (2000W, $t_p=8/20\mu s$) makes the LC05-6 suitable for telecommunications systems operating in harsh transient environments.

The LC05-6 is designed to meet the lightning surge requirements of Bellcore GR-1089 (intra-building), ITU K.20, and IEC 61000-4-5. The features of the LC05-6 are ideal for protecting T1/E1 transceivers in WAN applications.

Features

- ◆ Transient protection for high-speed data lines to Bellcore GR 1089 $I_{pp}=100A$ (2/10 μs)
ITU K.20 $I_{pp}=40A$ (5/310 μs)
IEC 61000-4-2 (ESD) >25kV
IEC 61000-4-4 (EFT) 40A (5/50ns)
IEC 61000-4-5 (Lightning) 100A (8/20 μs)
- ◆ Protects two tip and ring line pairs
- ◆ Low capacitance for high-speed interfaces
- ◆ High surge capability
- ◆ Low clamping voltage
- ◆ Solid-state silicon avalanche technology

Mechanical Characteristics

- ◆ JEDEC SO-16 package
- ◆ Molding compound flammability rating: UL 94V-0
- ◆ Marking : Part number, date code, logo
- ◆ Packaging : Tube or Tape and Reel per EIA 481

Applications

- ◆ T1/E1 Line Cards
- ◆ Base Stations
- ◆ WAN Equipment
- ◆ CSU/DSU
- ◆ Multiplexers
- ◆ Routers
- ◆ ISP Equipment
- ◆ Customer Premise Equipment

Circuit Diagram

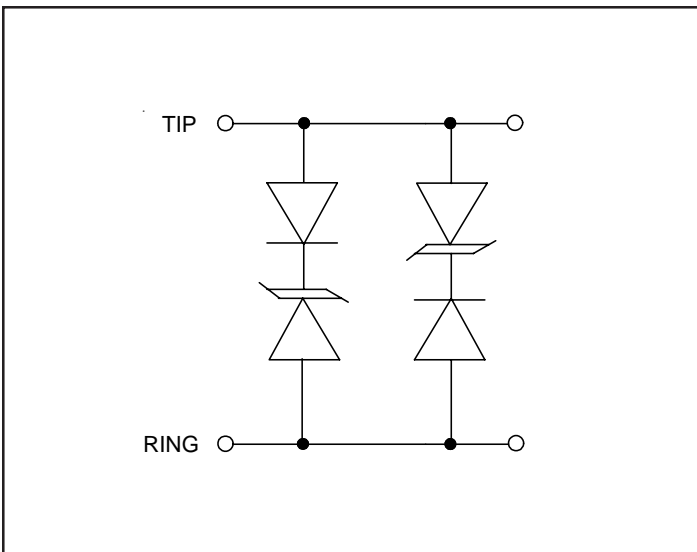

Schematic & PIN Configuration

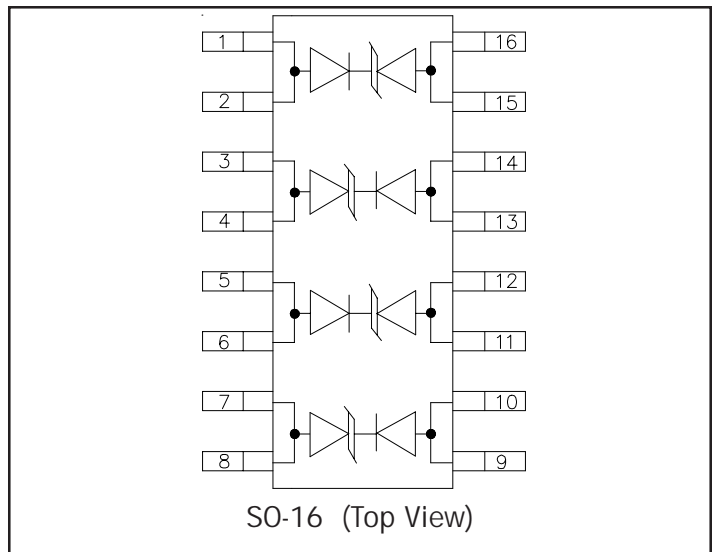

PROTECTION PRODUCTS

Absolute Maximum Rating

Rating	Symbol	Value	Units
Peak Pulse Power ($t_p = 8/20\mu s$)	P_{pk}	2000	Watts
Peak Pulse Current ($t_p = 8/20\mu s$)	I_{pp}	100	A
Lead Soldering Temperature	T_L	260 (10 sec.)	$^{\circ}C$
Operating Temperature	T_J	-55 to +125	$^{\circ}C$
Storage Temperature	T_{STG}	-55 to +150	$^{\circ}C$

Electrical Characteristics

LC05-6						
Parameter	Symbol	Conditions	Minimum	Typical	Maximum	Units
Reverse Stand-Off Voltage	V_{RWM}				6	V
Reverse Breakdown Voltage	V_{BR}	$I_t = 1mA$	6.8			V
Reverse Leakage Current	I_R	$V_{RWM} = 6V, T=25^{\circ}C$			15	μA
		$V_{RWM} = 3V, T=25^{\circ}C$			2	μA
Clamping Voltage	V_C	$I_{pp} = 10A,$ $t_p = 10/1000\mu s$			12.5	V
Clamping Voltage	V_C	$I_{pp} = 50A,$ $t_p = 8/20\mu s$			15	V
Clamping Voltage	V_C	$I_{pp} = 100A,$ $t_p = 8/20\mu s$			20	V
Junction Capacitance	C_J	Each Line $V_R = 0V, f = 1MHz$			15	pF

PROTECTION PRODUCTS

Typical Characteristics

Non-Repetitive Peak Pulse Power vs. Pulse Time

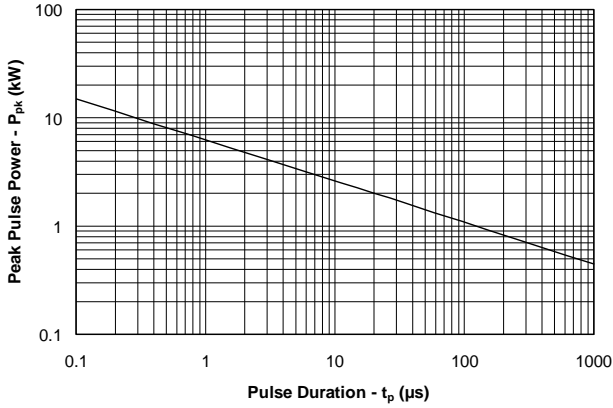

Power Derating Curve

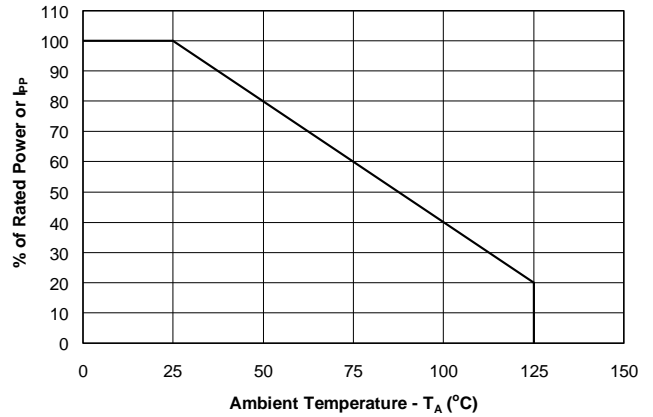

Pulse Waveform

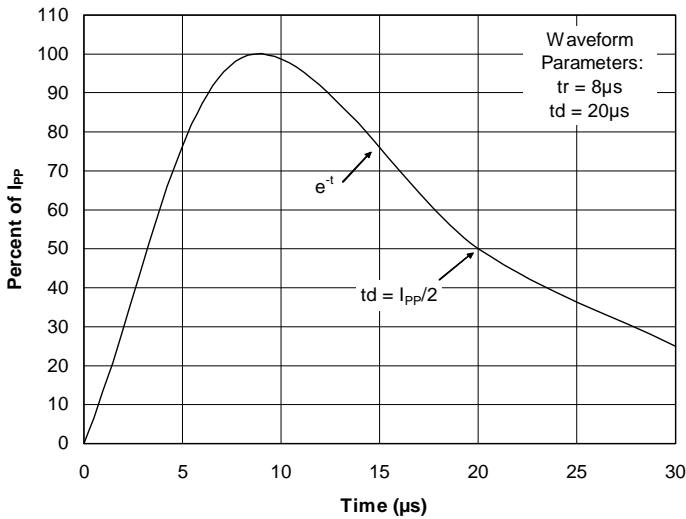

Clamping Voltage vs. Peak Pulse Current

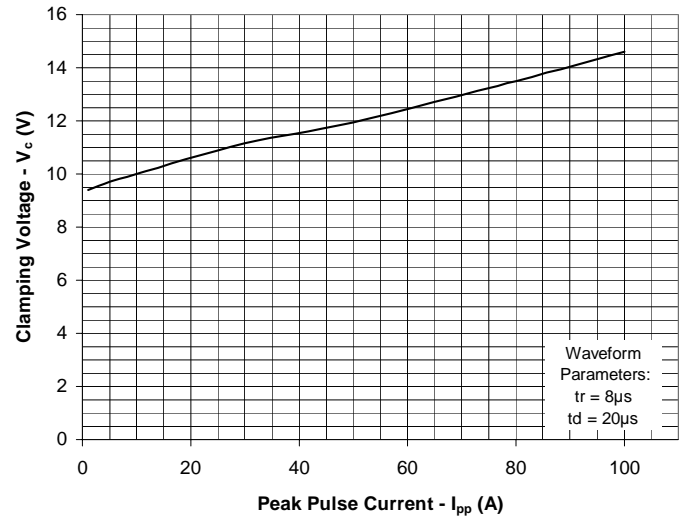

Capacitance vs. Reverse Voltage

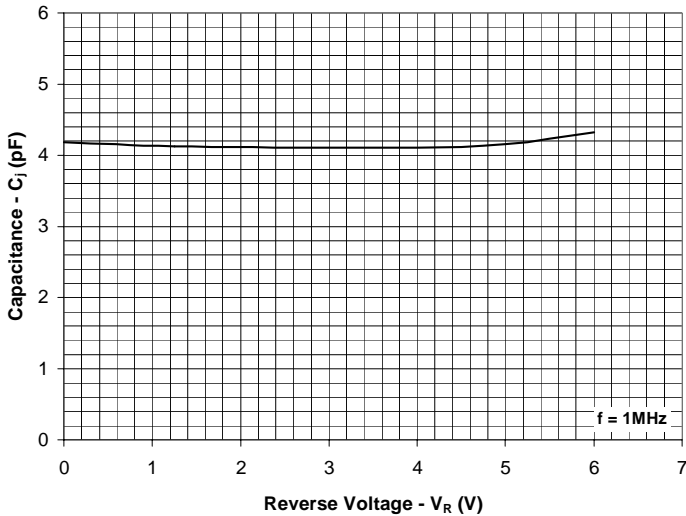

PROTECTION PRODUCTS

Applications Information

Device Connection Options for Protection of Two High-Speed Line Pairs

The LC05-6 is designed to protect four high-speed data lines (two differential pairs) from transient over-voltages which result from lightning and ESD. Protection of two line pairs is achieved by connecting the device as follows: Pins 1-4 are connected to line 1 of the first pair (i.e. Tip 1) and pins 13-16 are connected to line 2 of the first pair (i.e. Ring 1). Pins 5-8 are connected to line 1 of the second pair (i.e. Tip 2) and pins 9-12 are connected to line 2 of the second pair (i.e. Ring 2). All pins should be connected for best results. Minimize parasitic inductance in the protection circuit path by keeping the trace length between the protected line and the LC05-6 as short as possible.

T1/E1 Linecard Protection

A typical T1/E1 linecard protection circuit is shown in Figure 2. The LC05-6 is connected between Tip & Ring on the transmit and receive line pairs. It provides protection to metallic (line-to-line) lightning and ESD surges. It is designed to meet the intra-building requirements of Bellcore GR-1089. This design takes advantage of the isolation of the transformer to suppress common mode surges. To complete the protection circuit, the SRDA05-4 (or SRDA3.3-4 for 3.3V supplies) is employed as the IC side protection element. This device helps prevent the transceiver from latching up by providing fine clamping of transients that are coupled through the transformer.

Figure 1 - Connection for Differential (Line-to-Line) Protection of two Tip/Ring Line Pairs

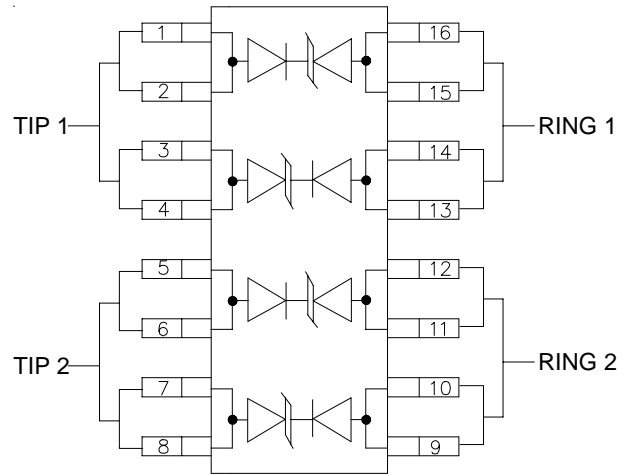

PROTECTION PRODUCTS
Typical Applications

Figure 2 - T1/E1 Line Card Protection

PROTECTION PRODUCTS

Outline Drawing - SO-16

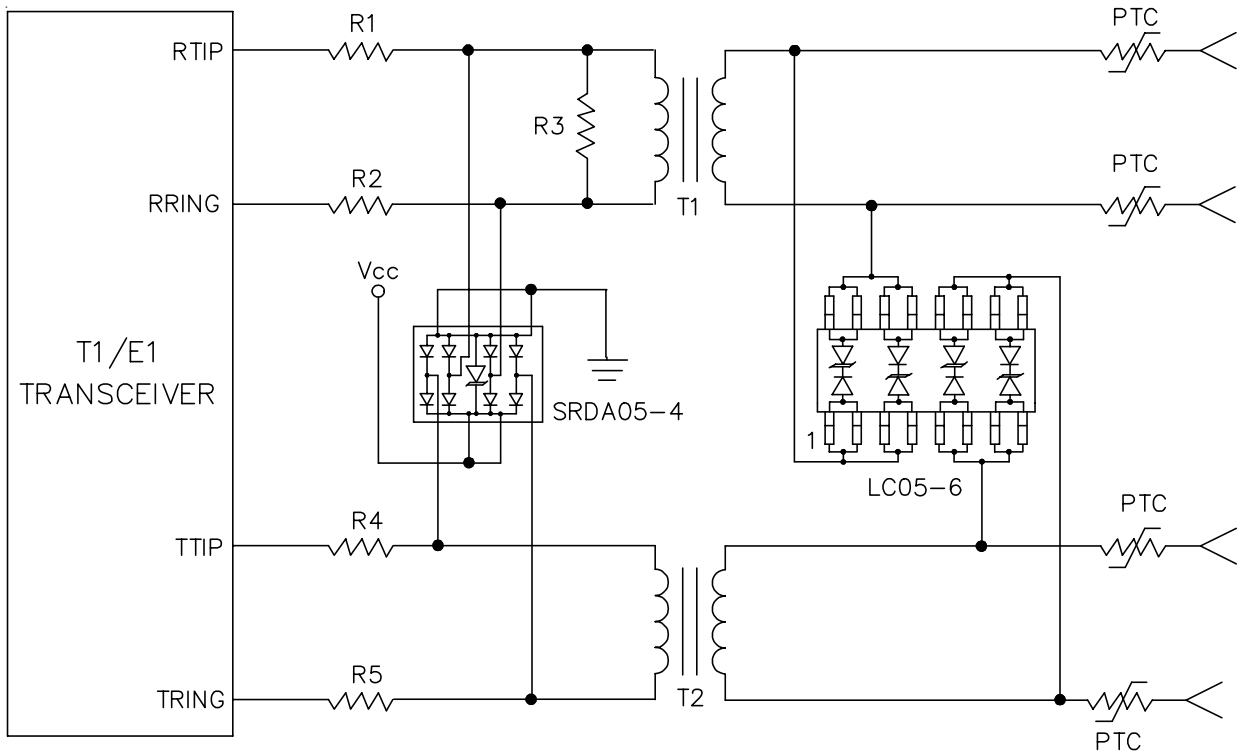
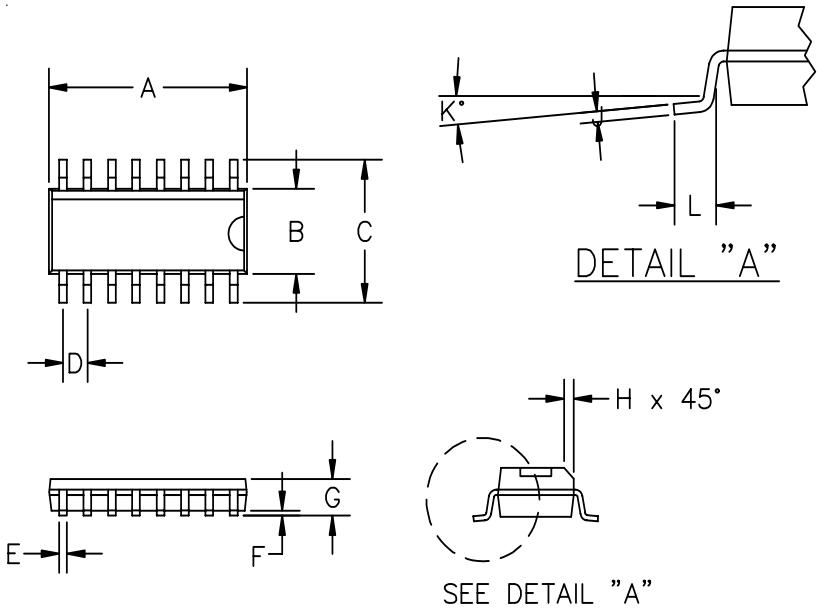

DIM ^N	INCHES		MM		NOTE
	MIN	MAX	MIN	MAX	
A	.386	.393	9.80	10.0	②
B	.150	.158	3.80	4.00	②
C	.228	.244	5.80	6.20	—
D	.050	BSC	1.27	BSC	—
E	.013	.020	0.33	0.51	—
F	.004	.010	.10	.25	—
G	.053	.069	1.35	1.75	—
H	.010	.020	.25	.50	—
J	.007	.010	.19	.25	—
K	0°	8°	0°	8°	—
L	.016	.050	.40	1.27	—

② DIMENSIONS A AND B DO NOT INCLUDE MOLD PROTUSIONS

Land Pattern - SO-16

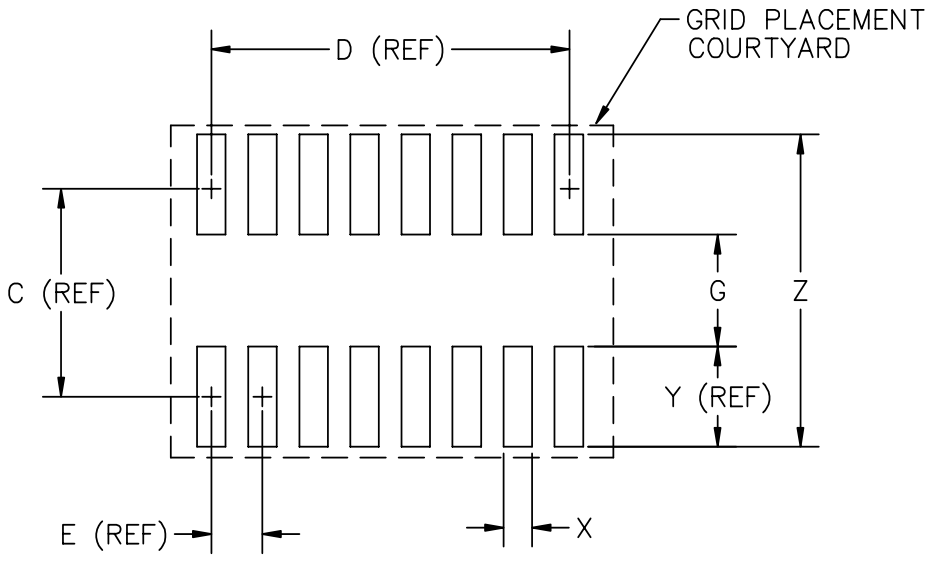

DIM ^N	INCHES		MM		NOTE
	MIN	MAX	MIN	MAX	
C	—	.197	—	5.00	—
D	—	.35	—	8.89	—
E	—	.05	—	1.27	—
G	.102	.110	2.60	2.80	—
X	.02	.03	.60	.80	—
Y	—	.095	—	2.40	—
Z	.28	.29	7.20	7.40	—

① GRID PLACEMENT COURTYARD IS 22 X 16 ELEMENTS (11mm X 8mm) IN ACCORDANCE WITH THE INTERNATIONAL GRID DETAILED IN IEC PUBLICATION 97.

PROTECTION PRODUCTS**Ordering Information**

Part Number	Working Voltage	Qty per Reel	Reel Size
LC05-6.TB	6V	500	7 Inch
LC05-6.TE	6V	2500	13 Inch

Note:



(1) No suffix indicates tube pack.

Contact Information

Semtech Corporation
Protection Products Division
200 Flynn Road, Camarillo, CA 93012
Phone: (805)498-2111 FAX (805)498-3804

Looking for pricing, stock, or lifecycle information?

Click below to explore more details on WIN SOURCE:

-  [View LC05-6.TBT on WIN SOURCE](#)
-  [Semtech Corporation](#) Information

Optimize Your Supply Chain with WIN SOURCE Solutions

-  Global Sourcing Solution
-  Obsolete Management
-  Cost Control Management
-  Shortage Management
-  Alternative Solution
-  Excess Inventory Management