



ON Semiconductor®

<http://onsemi.com>

LB1846MC

Monolithic Digital IC Low-Voltage/Low Saturation Voltage Type Bidirectional Motor Driver

Overview

The LB1846MC is 2-channel low-voltage, low saturation voltage type bidirectional motor driver IC that is optimal for use as 2-phase stepping motor drivers in printers, cameras and other portable equipment. The output circuits are of the bipolar type, with PNP transistors in the upper side and NPN transistors in the lower side, and they achieve low saturation output and low power characteristics despite being provided in a miniature package.

The LB1846MC products can directly control a motor from signals from a microcontroller. The LB1846MC is optimal for 1-2 phase excitation drive for 2-phase stepping motors using 4-input logic (IN1, IN2, IN3 and IN4).

Another point is that these IC include built-in thermal shutdown circuits so that IC scorching or burning is prevented in advance even if the IC output is shorted.

Functions

- Optimal for 1-2 phase excitation drive for 2-phase stepping motors
- Low saturation voltage. V_O (sat) = 0.55V typical at $I_O = 400\text{mA}$
- No limitations on the magnitude relationship between the power supply voltage (V_{CC}) and the input voltage (V_{IN})
- Standby current: Zero
- Thermal shutdown circuit

Specifications

Absolute Maximum Ratings at $T_a = 25^\circ\text{C}$

| Parameter | Symbol | Conditions | Ratings | Unit |
|-----------------------------|--------------|---------------|-------------------|------------------|
| Maximum supply voltage | V_{CC} max | | -0.3 to +8.0 | V |
| Output voltage | V_{OUT} | | $V_{CC} + V_{SF}$ | V |
| Input voltage | V_{IN} | | -0.3 to +8.0 | V |
| Ground pin outflow current | I_{GND} | Per channel | 800 | mA |
| Allowable power dissipation | P_d max | When mounted* | 870 | mW |
| Operating temperature | T_{opr} | | -20 to +75 | $^\circ\text{C}$ |
| Storage temperature | T_{stg} | | -40 to +150 | $^\circ\text{C}$ |

*1: When mounted on the specified printed circuit board (114.3mm × 76.2mm × 1.5mm), glass epoxy board

Caution 1) Absolute maximum ratings represent the value which cannot be exceeded for any length of time.

Caution 2) Even when the device is used within the range of absolute maximum ratings, as a result of continuous usage under high temperature, high current, high voltage, or drastic temperature change, the reliability of the IC may be degraded. Please contact us for the further details.

Stresses exceeding Maximum Ratings may damage the device. Maximum Ratings are stress ratings only. Functional operation above the Recommended Operating Conditions is not implied. Extended exposure to stresses above the Recommended Operating Conditions may affect device reliability.

LB1846MC

Allowable Operating Ranges at $T_a = 25^\circ\text{C}$

| Parameter | Symbol | Conditions | Ratings | Unit |
|--------------------------|----------|------------|--------------|------|
| Supply voltage | V_{CC} | | 2.5 to 7.5 | V |
| Input high-level voltage | V_{IH} | | 2.5 to 7.5 | V |
| Input low-level voltage | V_{IL} | | -0.3 to +0.7 | V |

Electrical Characteristics at $T_a = 25^\circ\text{C}$, $V_{CC} = 5\text{V}$

| Parameter | Symbol | Conditions | Ratings | | | Unit |
|---------------------------|--------------|--|---------|------|-----|---------------|
| | | | min | typ | max | |
| Current drain | I_{CC0} | IN1, 2, 3, 4 = 0V | | 0.1 | 10 | μA |
| | I_{CC1} | IN1, 3 = 3V, IN2, 4 = 0V | | 30 | 40 | mA |
| Output saturation voltage | V_{OUT1} | $V_{IN} = 3\text{V or } 0\text{V}$, $V_{CC} = 3 \text{ to } 7.5\text{V}$, $I_{OUT} = 200\text{mA}$ | | 0.27 | 0.4 | V |
| | V_{OUT2} | $V_{IN} = 3\text{V or } 0\text{V}$, $V_{CC} = 4 \text{ to } 7.5\text{V}$, $I_{OUT} = 400\text{mA}$ | | 0.55 | 0.8 | V |
| Input current | I_{IN} | $V_{IN} = 5\text{V}$ | | 150 | 200 | μA |
| Spark Killer Diode | | | | | | |
| Reverse current | I_S (leak) | | | | 30 | μA |
| Forward voltage | V_{SF} | $I_{OUT} = 400\text{mA}$ | | | 1.7 | V |

Package Dimensions

unit : mm (typ)

3420

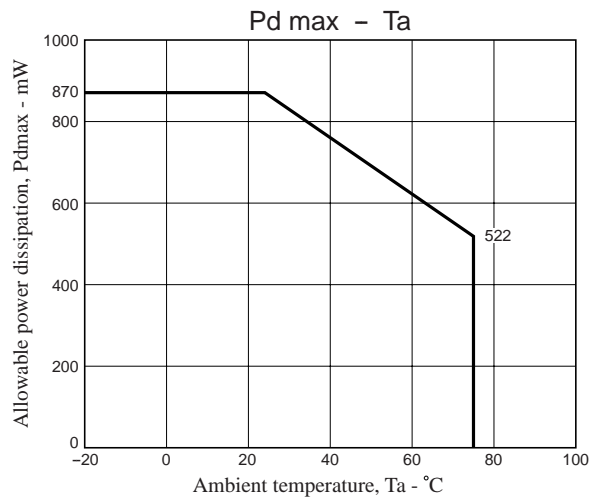
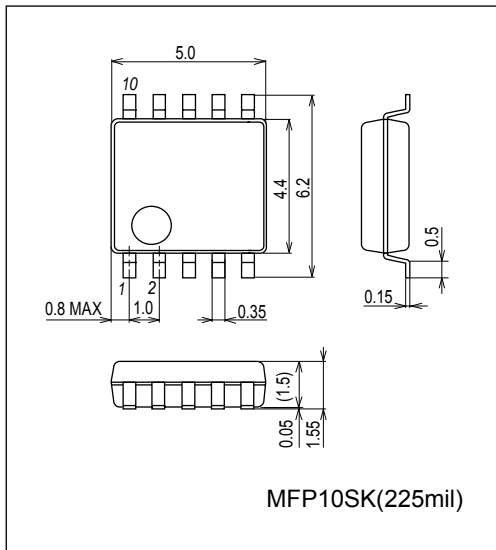

Pin Assignment

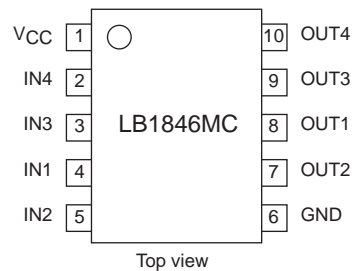

LB1846MC

Block Diagram

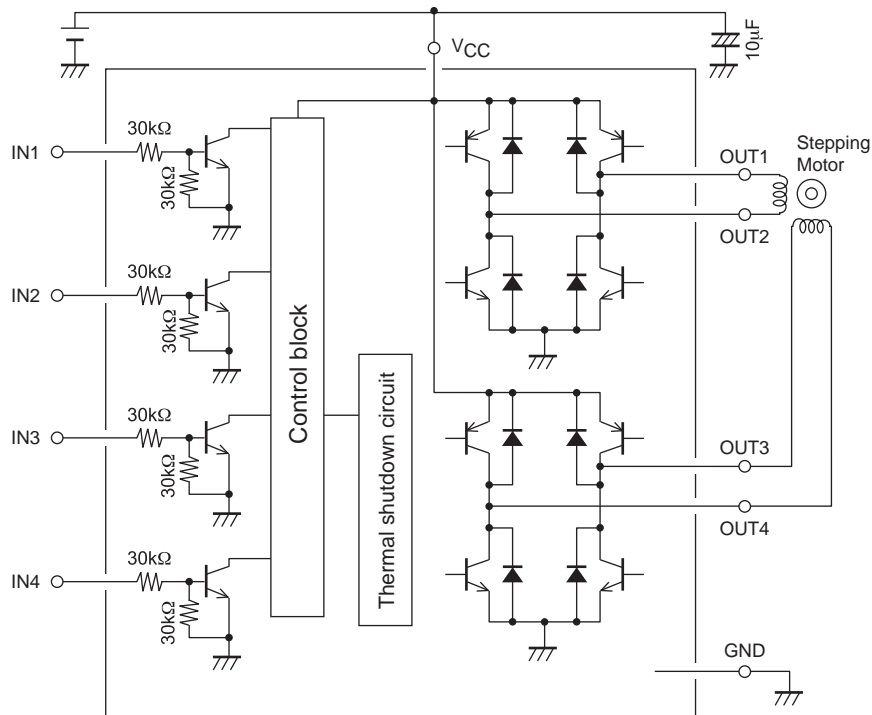

Truth Tables

| IN1 | IN2 | IN3 | IN4 | OUT1 | OUT2 | OUT3 | OUT4 | Note |
|-----|-----|-----|-----|------|------|------|------|---|
| L | L | L | L | OFF | OFF | OFF | OFF | Standby |
| H | L | L | L | H | L | OFF | OFF | |
| H | L | H | L | H | L | H | L | 1-2 phase excitation |
| L | L | H | L | OFF | OFF | H | L | |
| L | H | H | L | L | H | H | L | |
| L | H | L | L | L | H | OFF | OFF | |
| L | H | L | H | L | H | L | H | |
| L | L | L | H | OFF | OFF | L | H | |
| H | L | L | H | H | L | L | H | The logic output for the first high-level input is produced. *2 |
| H | H | - | - | | | | | |
| - | - | H | H | | | | | |

Note: *1 "-" indicates a "don't care" input.

*2 If two high levels (H/H) are input to the IN1/IN2 pins with the timing shown in (1) in the figure below, then the IN2 input that arrived later will be ignored and the IC will function as though an H/L combination is applied to the IN1/IN2 pins. Similarly, the timing shown in (2) results in a L/H combination on the IN1/IN2 pins.

(1)

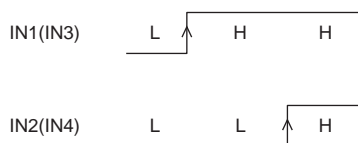

(2)

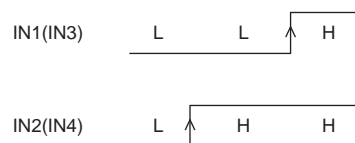

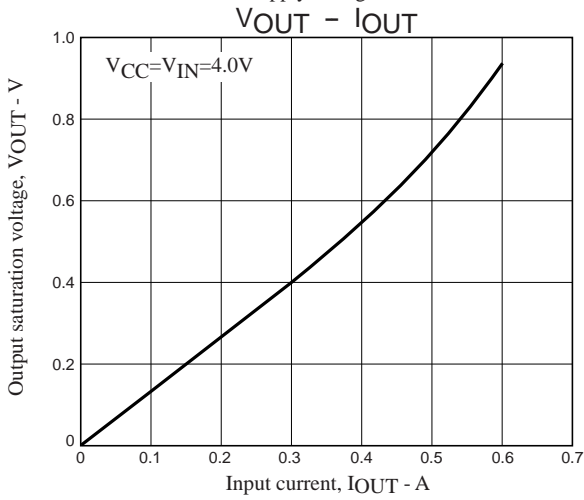
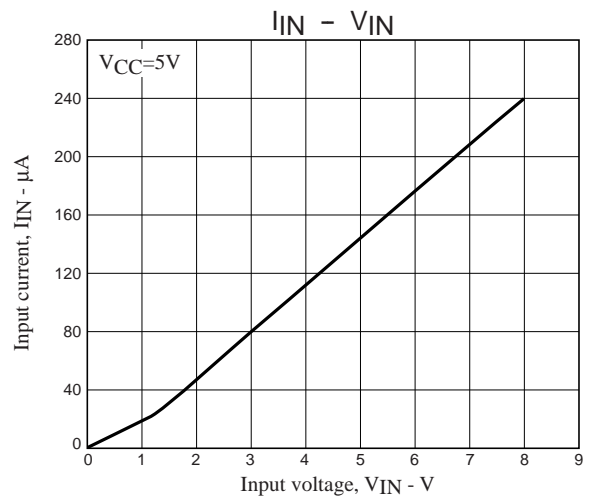
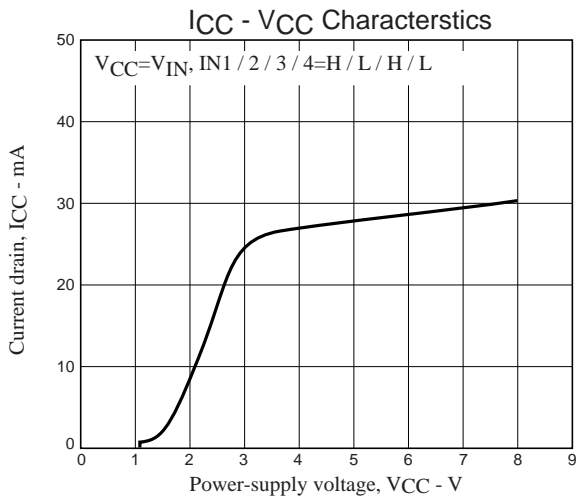



ON Semiconductor and the ON logo are registered trademarks of Semiconductor Components Industries, LLC (SCILLC). SCILLC owns the rights to a number of patents, trademarks, copyrights, trade secrets, and other intellectual property. A listing of SCILLC's product/patent coverage may be accessed at www.onsemi.com/site/pdf/Patent-Marking.pdf. SCILLC reserves the right to make changes without further notice to any products herein. SCILLC makes no warranty, representation or guarantee regarding the suitability of its products for any particular purpose, nor does SCILLC assume any liability arising out of the application or use of any product or circuit, and specifically disclaims any and all liability, including without limitation special, consequential or incidental damages. "Typical" parameters which may be provided in SCILLC data sheets and/or specifications can and do vary in different applications and actual performance may vary over time. All operating parameters, including "Typicals" must be validated for each customer application by customer's technical experts. SCILLC does not convey any license under its patent rights nor the rights of others. SCILLC products are not designed, intended, or authorized for use as components in systems intended for surgical implant into the body, or other applications intended to support or sustain life, or for any other application in which the failure of the SCILLC product could create a situation where personal injury or death may occur. Should Buyer purchase or use SCILLC products for any such unintended or unauthorized application, Buyer shall indemnify and hold SCILLC and its officers, employees, subsidiaries, affiliates, and distributors harmless against all claims, costs, damages, and expenses, and reasonable attorney fees arising out of, directly or indirectly, any claim of personal injury or death associated with such unintended or unauthorized use, even if such claim alleges that SCILLC was negligent regarding the design or manufacture of the part. SCILLC is an Equal Opportunity/Affirmative Action Employer. This literature is subject to all applicable copyright laws and is not for resale in any manner.

Looking for pricing, stock, or lifecycle information?

Click below to explore more details on WIN SOURCE:

-  [View LB1846MCGEVB on WIN SOURCE](#)
-  [ON Semiconductor](#) Information

Optimize Your Supply Chain with WIN SOURCE Solutions

-  Global Sourcing Solution
-  Obsolete Management
-  Cost Control Management
-  Shortage Management
-  Alternative Solution
-  Excess Inventory Management