



**THE DATASHEET OF  
LA72912V-TLM-H**



# LA72912V

## FM Modulator and Demodulator IC

### Overview

The LA72912V is a FM modulation and demodulation single-chip IC. Its adjustment free modulation/demodulation circuit significantly reduces the number of peripheral circuits required and can contribute to lower production costs.

### Functions

- ASK Modulation and Demodulation
- Video Signal FM Modulation and Demodulation
- Video Signal Emphasis and De-emphasis Function
- Drop-Out Detecting Function of Video FM Signal
- FM Mute Function at Second-Call

### MAXIMUM RATINGS (T<sub>A</sub> = 25°C)

Parameter	Symbol	Conditions	Ratings	Unit
Maximum Supply Voltage	V <sub>CC</sub> max		7.0	V
Allowable Power Dissipation	P <sub>d</sub> max		300	mW
Operating Temperature	T <sub>opr</sub>	T <sub>A</sub> ≤ 70°C (Note 1)	-30 to +70	°C
Storage Temperature	T <sub>stg</sub>		-40 to +150	°C

Stresses exceeding those listed in the Maximum Ratings table may damage the device. If any of these limits are exceeded, device functionality should not be assumed, damage may occur and reliability may be affected.

1. Mounted on a 114.3 mm × 76.1 mm × 1.6 mm, glass epoxy board.

### RECOMMENDED OPERATING CONDITIONS (T<sub>A</sub> = 25°C)

Parameter	Symbol	Conditions	Ratings	Unit
Recommended Supply Voltage	V <sub>CC</sub>		5.0	V
Allowable Operating Voltage Range	V <sub>CC</sub> op	T <sub>A</sub> = -30 to +70°C	4.7 to 5.5	V

Functional operation above the stresses listed in the Recommended Operating Ranges is not implied. Extended exposure to stresses beyond the Recommended Operating Ranges limits may affect device reliability.



ON Semiconductor®

[www.onsemi.com](http://www.onsemi.com)

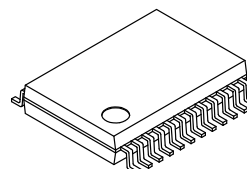

SSOP24  
CASE 565AQ

### MARKING DIAGRAM

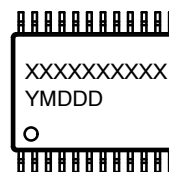

XXXXX = Specific Device Code  
Y = Year  
M = Month  
DDD = Additional Traceability Data

### ORDERING INFORMATION

Device	Package	Shipping†
LA72912V-TLM-H	SSOP24 (Pb-Free/ Halogen Free)	1,000 / Tape & Reel

†For information on tape and reel specifications, including part orientation and tape sizes, please refer to our Tape and Reel Packaging Specification Brochure, BRD8011/D.

# LA72912V

## ELECTRICAL CHARACTERISTICS (T<sub>A</sub> = 25°C, V<sub>CC</sub> = 5.0 V)

Parameter	Symbol	In	Out	Conditions	Min	Typ	Max	Unit
-----------	--------	----	-----	------------	-----	-----	-----	------

### DC CHARACTERISTICS (T<sub>6</sub> = 0.4 V, T<sub>17</sub> = 2.0 V, T<sub>18</sub> = 0.4 V)

Control Terminal (Pin 6,9) Low Level	CNT6L CNT17L	T6 T17		Low level of control terminal of ALL mode. T <sub>6</sub> = 0.4 V (DEMOD mode), T <sub>17</sub> = 0.4 V (Standby mode)	0		0.4	V
Control Terminal (Pin 6,9) High Level	CNT6H CNT17H	T6 T17		High level of input terminal of ALL mode T <sub>6</sub> = 2.0 V (MOD mode), T <sub>17</sub> = 2.0 V (Normal mode)	2.0		5.0	V
Input5 Low Level	IN5L	T5		Low level of input terminal of MOD mode T <sub>6</sub> = 2.0 V, T <sub>17</sub> = 2.0 V, T <sub>18</sub> = 0.4 V	0		0.4	V
Input5 High Level	IN5H	T5		High level of input terminal of MOD mode T <sub>6</sub> = 2.0 V, T <sub>17</sub> = 2.0 V, T <sub>18</sub> = 0.4 V	2.0		5.0	V
Input18 Low Level	IN18L	T18		Low level of input terminal of MOD mode T <sub>5</sub> = 0.4 V, T <sub>6</sub> = 2.0 V, T <sub>17</sub> = 2.0 V	0		0.4	V
Input18 High Level	IN18H	T18		High level of input terminal of MOD mode T <sub>5</sub> = 0.4 V, T <sub>6</sub> = 2.0 V, T <sub>17</sub> = 2.0 V	2.0		5.0	V
Output18 Terminal High Level	OPH18		T18	DEMOD mode: FM-Signal input T <sub>6</sub> = 0.4 V, T <sub>17</sub> = 2.0 V, Pull-up: 15 kΩ	4.7			V
Output18 Terminal Low Level	OPL13 OPL18		T18	T18: DEMOD mode: FM No-signal Measure the sink level of output terminal. T <sub>6</sub> = 0.4 V, T <sub>17</sub> = 2.0 V, Pull-up: 15 kΩ	0	0.25	0.4	V
Input20 Low Level	IN20L	T20	T20	Voltage of terminal at AGC ON T <sub>6</sub> = 0.4 V, T <sub>17</sub> = 2.0 V	0		3	V
Input20 High Level	IN20H	T20	T20	Voltage of terminal at AGC OFF T <sub>6</sub> = 0.4 V, T <sub>17</sub> = 2.0 V	4.5		5.0	V
5pin AC Input Dynamic Range	ACIN5	T5A	T3	Input amplitude level of FM signal Freq: 11.5 MHz to 13.5 MHz			1000	mVp-p
16pin AC Input Dynamic Range	ACIN16	T24A	T3	Maximum input level of T24A at Video signal			1.5	Vp-p

### VIDEO FM MODULATION BLOCK (MOD) (T<sub>6</sub> = 2.0 V, T<sub>17</sub> = 2.0 V, T<sub>18</sub> = 0.4 V)

Current Dissipation	I <sub>CCR</sub>			Measure the currents into pins 2 (MOD mode)	22.0	27.0	32.0	mA
FM Modulator Output Level	VFM1		T3	Measure the output level on T3 (No signal input) It is load impedance 200 Ω between T3-GND.		1.8	2.2	Vp-p
FM Mute Output Level	VFM2		T3	Measure the T3 output level with 2nd call	0	10	20	mVp-p
Carrier Frequency	FFM		T3	Measure the output frequency on T3 with no signal input	10.9	11.5	12.1	MHz
FM Output Second Harmonic Distortion	THD2		T3	Measure the second harmonics distortion with the above condition		-30	-20	dB

# LA72912V

## ELECTRICAL CHARACTERISTICS (T<sub>A</sub> = 25°C, V<sub>CC</sub> = 5.0 V) (continued)

Parameter	Symbol	In	Out	Conditions	Min	Typ	Max	Unit
-----------	--------	----	-----	------------	-----	-----	-----	------

### VIDEO FM MODULATION BLOCK (MOD) (T<sub>6</sub> = 2.0 V, T<sub>17</sub> = 2.0 V, T<sub>18</sub> = 0.4 V)

Deviation	DEV	T24A	T3	With T24A 100% White 1Vp-p signal, Measure the deviation on T3	1.9	2.0	2.1	MHz
FM Modulator Linearity (11.5 to 13.5 MHz)	LMOD	T24A	T3	Let f <sub>2.85</sub> , f <sub>3.35</sub> and f <sub>3.85</sub> be the output frequency when 2.85 V, 3.35 V and 3.85 V is applied to T24A LMOD = $\{ [f_{3.35} - (f_{3.85} + f_{2.85}) / 2] / (f_{3.85} - f_{2.85}) \} \times 100\}$	-2	0	+2	%
Emphasis Gain	GEMP	T24A	T20	With V <sub>IN</sub> a 300 mVp-p 10 kHz sine wave, Measure the ratio of the levels on T24A and T20	-7.5	-6.0	-4.5	dB
Main Linear Emphasis Characteristics(1)	GME1	T24A	T20	With V <sub>IN</sub> a 300 mVp-p 500 kHz sine wave, Measure the ratio of the levels on T24A and T20	0.0	1.5	3.0	dB
Main Linear Emphasis Characteristics(2)	GME2	T24A	T20	With V <sub>IN</sub> a 300 mVp-p 2 MHz sine wave, Measure the ratio of the levels on T24A and T20	4.0	5.5	7.0	dB
White Clipping Level	LWC	T24A	T20	With V <sub>IN</sub> a 1.5 Vp-p 100% white video signal. Measure the white clipping level on T20	180	200	220	%
Dark Clipping Level	LDC	T24A	T20	With V <sub>IN</sub> a 1.5 Vp-p 100% white video signal. Measure the dark clipping level on T20.	-60	-50	-40	%
FM Stop Beginning Delay Time (VD Characteristic 1B)	TC1	T5	T3	C7 = 0.01 μF, Time from fall of T5 signal to doing of FM carrier of T3 STOP	240	300	360	μs
FM Stop Time (VD Characteristic 2A)	TC2	T5	T3	C8 = 0.001 μF, Stop time of FM carrier of T3	30	40	50	μs
Minimum VD Pulse Width	VDT	T5	T3	C7 = 0.01 μF, Minimum VD pulse width to which TC1B is normally output	63			μs

### VIDEO FM DE-MODULATION BLOCK (DEMODO) (T<sub>6</sub> = 0.4 V, T<sub>17</sub> = 2.0 V)

Current Dissipation	I <sub>CCP</sub>			Measure the currents into pin 2 (DEMODO mode)	26.0	32.0	38.0	mA
Video Output Level	VOU	T5A	T3	Demodulation level, when the FM signal of 2.2 MHz deviation. Load impedance = 1 kΩ T3-GND.	2.09	2.2	2.31	Vp-p
Video Output Level B	VOU <sub>B</sub>	T5A	T3	Demodulation level, when the FM signal of 2.0 MHz deviation. Load impedance = 1 kΩ T3-GND. (In this case only, V <sub>CC</sub> make 4.5 V to 5.5 V.)	1.9	2.0	2.1	Vp-p
FM Stop Detection Level (DOC Characteristic 1)	DOC1	T5A T20	T18 T20	T5 = 11.5 MHz, 300 mVp-p. Measure T20 voltage (V20). Set T20 V20 (AGC-Fix). T5 input level when T5 amplitude is decrease gradually, and T18 becomes "Low"		40	60	mVp-p
(Drop Delay Down)	DDD	T5A T20	T18 T20	Shift time from T5 = 300 mVp-p → 0 mVp-p to T18 "Low"	0.5	1.5	2.5	μs

# LA72912V

## ELECTRICAL CHARACTERISTICS (T<sub>A</sub> = 25°C, V<sub>CC</sub> = 5.0 V) (continued)

Parameter	Symbol	In	Out	Conditions	Min	Typ	Max	Unit
<b>VIDEO FM DE-MODULATION BLOCK (DEM0D)</b> (T <sub>6</sub> = 0.4 V, T <sub>17</sub> = 2.0 V)								
FM Return Judgment Level	DOC2	T5A T20	T18 T20	T5 = 11.5 MHz, 300 mVp-p, Measure T20 Voltage (V20). Set T20 V20 (AGC-Fix). T5 inputs the level when T5 amplitude is increase gradually, and T18 becomes "High"		60	90	mVp-p
Video DC Level when Returning	DOC2B	T5A T20	T23	Confirmation of output of Video signal from T3. Measurement of DC level.	0.5	1.0	1.5	V
(Drop Delay Rise) Return Operation Delay Time	DWR	T5A T20	T18 T20	Shift time from T5 = 0 mVp-p → 3 00 mVp-p to T18 "High"	0.2	1.5	2.5	μs
4 V Regulator	VREG		T4	Measurement of T4 DC level	3.9	4.0	4.3	V
Range of Input Dynamic Range	ACIN5	T5A	T3	DEV = 2.0 MHz. Input amplitude level of FM signal. (T5A: 11.5 MHz to 13.5 MHz)		500	1000	mVp-p
DG	DG	T5A	T3		0	6	10	%
DP	DP	T5A	T3		0	6	10	deg
Output voltage at Mute	MUV		T3	Mute level measurement of T3	0	10	20	IRE
FM Demodulation Voltage (11.0M)	VDEM11 VDEM12 VDEM13	T5A	T23	T5A = 11.0 MHz, 100 mVp-p, 200 mVp-p and 400 mVp-p. Each T23 voltage measurement	0.3	0.8	1.3	V
FM Demodulation Voltage (12.5M)	VDEM21 VDEM22 VDEM23	T5A	T23	T5A = 12.5 MHz, 100 mVp-p, 200 mVp-p and 400 mVp-p. Each T23 voltage measurement	0.7	1.2	1.7	V
FM Demodulation Voltage (14.0M)	VDEM31 VDEM32 VDEM33	T5A	T23	T5A = 14 MHz, 100 mVp-p, 200 mVp-p and 400 mVp-p. Each T23 voltage measurement	1.1	1.6	2.1	V
FM Demodulation Linearity <sub>1,2,3</sub>	LDEM1 LDEM2 LDEM3			Calculate FM demodulation linearity LDEM1 = {[VDEM21 - (VDEM11 + VDEM31) / 2] / (VDEM31 - VDEM11)} × 100 LDEM2 = {[VDEM22 - (VDEM12 + VDEM32) / 2] / (VDEM32 - VDEM12)} × 100 LDEM3 = {[VDEM23 - (VDEM13 + VDEM33) / 2] / (VDEM33 - VDEM13)} × 100	-2	0	+2	%
FM Demodulation Sensitivity <sub>1,2,3</sub>	SDEM1 SDEM2 SDEM3			Calculate FM recovery Sensitivity with consider pin 3 output level conversion ratio. SDEM1 = (VDEM31 - VDEM11) / 3.0 SDEM2 = (VDEM32 - VDEM12) / 3.0 SDEM3 = (VDEM33 - VDEM13) / 3.0	0.28	0.33	0.38	V/MHz
Main Linear De-emphasis Amplitude	GMED	T5A	T23	T5 = 200 mVp-p FM signal (fm = 10 kHz, Center Carrier = 12.5 MHz, DEV = 2.0 MHz) Signal level of T23	481	535	589	mVp-p

# LA72912V

## ELECTRICAL CHARACTERISTICS (T<sub>A</sub> = 25°C, V<sub>CC</sub> = 5.0 V) (continued)

Parameter	Symbol	In	Out	Conditions	Min	Typ	Max	Unit
<b>VIDEO FM DE-MODULATION BLOCK (DEMODO) (T<sub>6</sub> = 0.4 V, T<sub>17</sub> = 2.0 V)</b>								
Main Linear De-emphasis Characteristics(1)	GMED1	T5A	T23	T5 = 200 mVp-p FM signal (fm = 500 kHz, Center Carrier = 12.5 MHz, DEV = 2.0 MHz). Signal level of T23 versus GMRD (Ratio of GMED).	-3.5	-1.5	+0.5	dB
Main Linear De-emphasis Characteristics(2)	GMED2	T5A	T23	T5 = 200 mVp-p FM signal (fm = 2 MHz, Center Carrier = 9.25 MHz, DEV = 2.0 MHz). Signal level of T23 versus GMRD (Ratio of GMED)	-6.5	-4.5	-2.5	dB
<b>ASK BLOCK (T<sub>17</sub> = 0.4 V)</b>								
Current Dissipation at Standby	I <sub>CCS</sub>	T17		At standby mode, measures include current to pin2,9. T17 = 0.4 V, T15 and T20: open	10.8	13.0	15.5	mA
Current Dissipation at Standby at MOD-AGC-OFF	I <sub>CCSb</sub>	T17 T15		At standby mode, measures include current to pin 2,9. T17 = 0.4 V, T15 = 5 V, T20: open	12.8	16.0	19.2	mA
Current Dissipation at Standby at DEMOD-AGC-OFF	I <sub>CCSc</sub>	T17 T15 T20		At standby mode, measures include current to pin 2,9. T17 = 0.4 V, T15 = 5 V, T20 = 5 V	16.8	21.0	25.2	mA
Standby Release Time(1) (FM stop → release)	SASK1	T6 T17	T3	T6 = 2.0 VDC T17 = 0 V → 2 V (Standby release) Time until FM carrier is output to T3	0.0	6.0	12.0	μs
Standby Release Time(2) (Video signal stop → release)	SASK2	T6 T5A T17	T3	T6 = 0.4 V, T5 = DEV = 2.0 MHz 100% white video signal of FM signal. T17 = 0 V → 2 V (Standby release) Time until white 100% signal is output to T3	2.0	7.0	12.0	μs
ASK Transmitting Time "transmission"	TASK1	T10A T11	T12	T10A = 1 MHz, 0/2 V Pulse T11 = 20 kHz, 0/2 V Pulse. Measure T12 signal appear time			0.1	ms
ASK Transmitting Time "Receive"	TASK2	T16A	T13	T16 = 1 MHz, 300 mVp-p-SIN wave Measure time T13 appear detected T16 signal			0.1	ms
ASK Transmission Setup Time	WASK	T10A T11	T12	T10A = 1 MHz, 0-2V-pulse T11 = 20 kHz, 0-2V-pulse Measure T11 input interval time when T10A input		10	100	ms
ASK Minimum Detect Level	VASK	T16A	T13	Measure T16 minimum level at T13 is normally condition	0.2		3	Vp-p
ASK Start Up Time	OASK	T16A	T13	Measure time ASK working from Power-ON	-	30	300	ms
ASK Demodulation Duty Ratio	DASK	T16A	T13	T16 = T12 output signal (0-2Vp-p) Measure ASK Duty difference with 50% DASK = (pulse width μs / 50 μs) - 50% × 100%	-15	-2	11	%

Product parametric performance is indicated in the Electrical Characteristics for the listed test conditions, unless otherwise noted. Product performance may not be indicated by the Electrical Characteristics if operated under different conditions.

# LA72912V

## PIN ASSIGNMENT

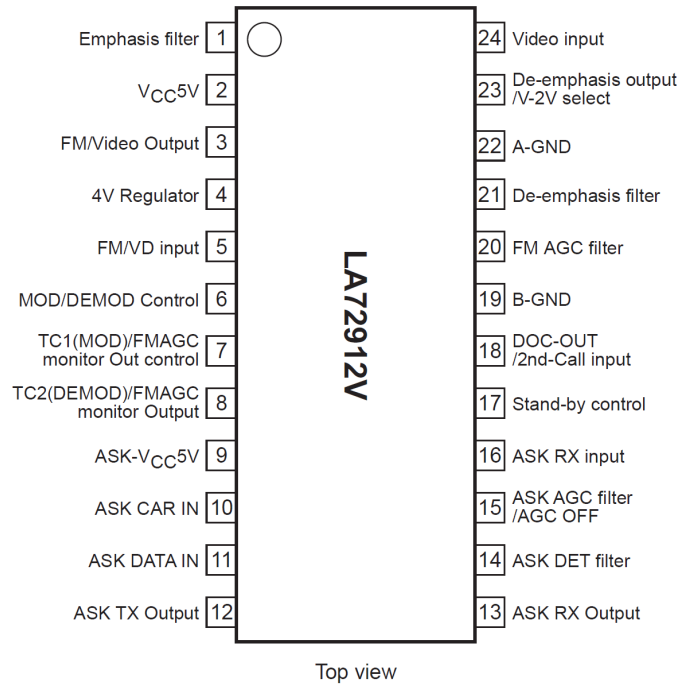

Figure 1. Pin Assignment

## BLOCK DIAGRAM AND APPLICATION CIRCUIT EXANPLE1 MODULATION (OUTSIDE CAMERA)

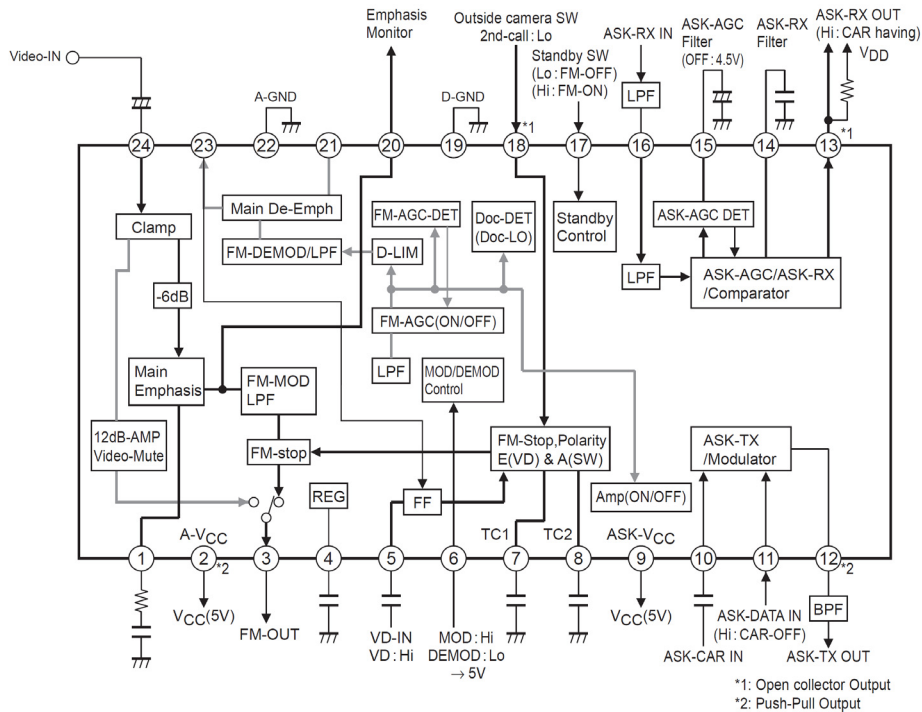

Figure 2. Block Diagram and Application Circuit Exanple1 Modulation (Outside Camera)

# LA72912V

## APPLICATION CIRCUIT EXAMPLE2 DEMODULATION (INSIDE MONITOR)

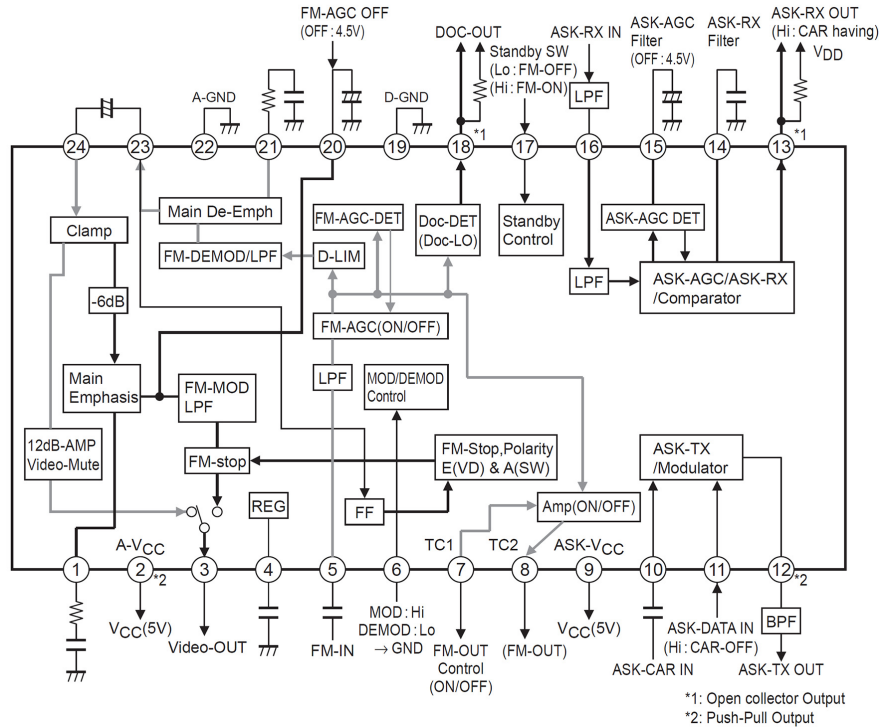

Figure 3. Application Circuit Example2 Demodulation (Inside Monitor)

### PIN FUNCTION

Pin No.	Pin Name	FM MOD Mode (Outside Camera)	FM DEMOD Mode (Inside Monitor)	Note
1	Emphasis Filter	Emphasis filter connection pin	Non connect (Hi-Z)	If you no need, this pin is open
2	V <sub>CC</sub> 5V	V <sub>CC</sub> for FM modulation	V <sub>CC</sub> for FM demodulation	
3	FM/Video Output	FM Output (R <sub>O</sub> = 200 Ω: 1.8 V <sub>p-p</sub> )	Video Output (R <sub>O</sub> = 1 kΩ: 2 V <sub>p-p</sub> )	Push-pull output
4	4 V Regulator	FM modulate block and ASK bock supply reference voltage.	FM demodulate block and ASK bock supply reference voltage.	
5	FM/VD Input	VD Input. (Hi: over 2 V, Low: under 0.4 V) (VD DET: High)	FM Input. (Recommend Level: 100 to 620 mV <sub>p-p</sub> )	DEMOD mode: Set 3.3 V by internal bias. (34 kΩ/66 kΩ)
6	MOD/DEMODO Control	Set over 2 V DC voltage.	Set under 0.4 V DC voltage.	Outside camera/Inside monitor setting.
7	TC1(MOD)/ FMAGC Monitor Out Control	Set capacitor for TC1	FMAGC monitor out control GND: Monitor ON/V <sub>CC</sub> : Monitor OFF	Can do second inside monitor addition
8	TC2(DEMOD)/ FMAGC Monitor Output	Set capacitor for TC2	FMAGC monitor output	Can do second inside monitor addition
9	ASK-V <sub>CC</sub> 5V	V <sub>CC</sub> for ASK	←	
10	ASK CAR IN	ASK carrier Input. (Recommend below 3 V <sub>p-p</sub> )	←	2.1 V by internal bias. (50 kΩ)
11	ASK DATA IN	ASK Data Input. (Hi: more than 2 V, Lo: below 0.4 V)	←	

## LA72912V

### PIN FUNCTION (continued)

Pin No.	Pin Name	FM MOD Mode (Outside Camera)	FM DEMOD Mode (Inside Monitor)	Note
12	ASK TX Output	ASK modulated signal Output	←	Push-pull output
13	ASK RX Output	ASK Demodulated Output	←	Open collector output ASK carrier detect = Lo
14	ASK DET Filter	ASK Detector filter	←	
15	ASK AGC Filter/ AGC OFF	AGC filter for ASK. (When AGC operate voltage is 0 V to 3 V, AGC stop when you add over 4.5 V.)	←	
16	ASK RX Input	ASK Demodulate Input	←	3.3 V by internal bias. (34 k $\Omega$ /66 k $\Omega$ )
17	Standby Control	FM blocks standby control. (FM block operate: over 2 V, FM block standby: under 0.4 V )	←	
18	DOC-OUT/ 2nd-Call Input	2ND-Call input, 2ND-Call: Low (High: over 2 V, Low: under 0.4 V)	DOC output (When DO-DET, output is Low)	DEMODO mode: Open collector output.
19	B-GND	Circuit GND	←	
20	FM AGC Filter	Emphasis monitor output	FM AGC control filter (AGC-ON: 0 to 3 V DC, AGC-OFF: 4.5 to 5 V by external DC voltage.)	MOD mode: Don't connect capacitor
21	De-emphasis Filter	Non connect (Hi-Z)	De-emphasis filter connection pin	If you don't need, this pin is open
22	A-GND	Circuit GND	←	
23	De-emphasis Output/ V-2V Select	DFF for V-diff control (ON: over 2 V, OFF: under 0.4 V)	DE-emphasis output	MOD mode; VD diff. Count select 0 V: VD through 2 V: VD 1/2 diff
24	Video Input	Video signal input. (from outside CCD camera: 1 Vp-p)	Video signal input. (from de-emphasis block: 0.5 Vp-p)	MOD mode: Maximum video input level is 1.5 Vp-p.

PIN DESCRIPTION

Pin No.	Pin Name	Description	Equivalent Circuit
1	Emphasis Filter	Main Emphasis filter pin. Before FM Modulation, make emphasis characteristic at video signal. Emphasis time constant must be matching at de-emphasis time constant. (If you don't need the emphasis, this pin is open.)	
2	V <sub>CC</sub> 5V	V <sub>CC</sub> pin. Supply voltage is 5 V DC. Please connect de-coupling capacitor.	
3	FM/Video OUT	Push-Pull output pin. MOD mode: FM carrier output. (1.8 V <sub>p-p</sub> : R <sub>out</sub> = 200 Ω) DEMOD mode: Video signal output. (2.0 V <sub>p-p</sub> : R <sub>out</sub> = 1 kΩ)	
4	Regulator Filter	Internal regulator filter pin. Please connect 0.1 μF (C1).	
5	FM/VD Input	DEMOD mode: FM signal input. Internal DC bias is 3.3 V. Please use capacitor (C1) coupling. MOD mode: VD signal input. Please input VD signal directory. Please consider input impedance.	
6	MOD/DEMOM Control	MOD mode/DEMOM mode setting pin. MOD mode: Please set over 2 V DC voltage. (2 to 5 V). DEMOM mode: Please set under 0.4 V DC voltage. (0 to 0.4 V).	

# LA72912V

## PIN DESCRIPTION (continued)

Pin No.	Pin Name	Description	Equivalent Circuit
7	TC1(MOD)/ FMAGC Monitor Control	MOD mode: TC1 filter pin. Please connect C1. DEMOM mode: FM-AGC monitor on/off control. GND: AGC-monitor ON VCC: AGC-monitor OFF	
8	TC2(DEMOD)/ FMAGC Monitor Output	MOD mode: TC2 filter pin. Please connect C1. DEMOM mode: FM-AGC-monitor output	
9	ASK-V <sub>CC</sub> 5V	ASK block VCC. Please supply DC 5 V with use capacitor for de-coupling.	
10	ASK CAR IN	ASK carrier input Pin. Please connect with capacitor, 2.1 V by internal biased.	
11	ASK DATA IN	ASK data input pin. L level is lower than 0.4 V H level is more than 2 V	
12	ASK TX Output	ASK output pin. Push-pull type output.	
13	ASK RX Output	ASK detect output. Open corrector type output.	

# LA72912V

## PIN DESCRIPTION (continued)

Pin No.	Pin Name	Description	Equivalent Circuit
14	ASK RX Filter	ASK detect filter. Connect capacitor for reject of ASK AC component.	
15	ASK AGC Filter/ AGC OFF	AGC filter pin for ASK. Please connect pull-up resistance to this pin, and do more than 4.5 V at voltage of this pin.	
16	ASK RX Input	ASK input pin. Please connect with capacitor, 3.3 V by internal biased.	
17	Standby Control	Standby control pin. FM block standby: under 0.4 V DC voltage. (0 to 0.4 V) FM block operate: over 2 V DC voltage. (2 to 5 V)	
18	DOC-OUT/ 2nd-Call Input	DEMOD mode: Drop-out output pin. This pin is open collector output, so please connect pull up resistor. MOD mode: 2ND-CALL input. 2ND-CALL input: under 0.4 V DC voltage. (0 to 0.4 V) Normal: over 2 V DC voltage. (2 to 5 V)	
19	B-GND	Circuit GND	
20	FM AGC Filter	MOD mode: Emphasis monitor pin. DEMOD mode: FM AGC filter pin. If FM AGC no need (= AGC Off), Please set pin 12 voltage over 4.5 V DC voltage. (4.5 to 5 V)	

# LA72912V

## PIN DESCRIPTION (continued)

Pin No.	Pin Name	Description	Equivalent Circuit
21	De-emphasis Filter	DEMODO mode: De-emphasis filter pin. De-emphasis time constant must be matching at emphasis time constant. (If you don't need the emphasis, this pin is open.)	
22	A-GND	Circuit GND	
23	De-emphasis Output/V-2V Select	DEMODO mode: Video signal output after De-emphasis. Output level is 0.5 Vp-p. Connect capacitor to clamp input (pin 16). MOD mode: DFF control pin. DFF is ON at over 2 V DC voltage. (2 to 5 V)	
24	Video Input	MOD mode: Video signal input pin (from camera). Input level is 1 Vp-p. DEMODO mode: Video signal input pin (from de-emphasis). Input level is 0.5 Vp-p.	

# LA72912V

## TEST CIRCUIT

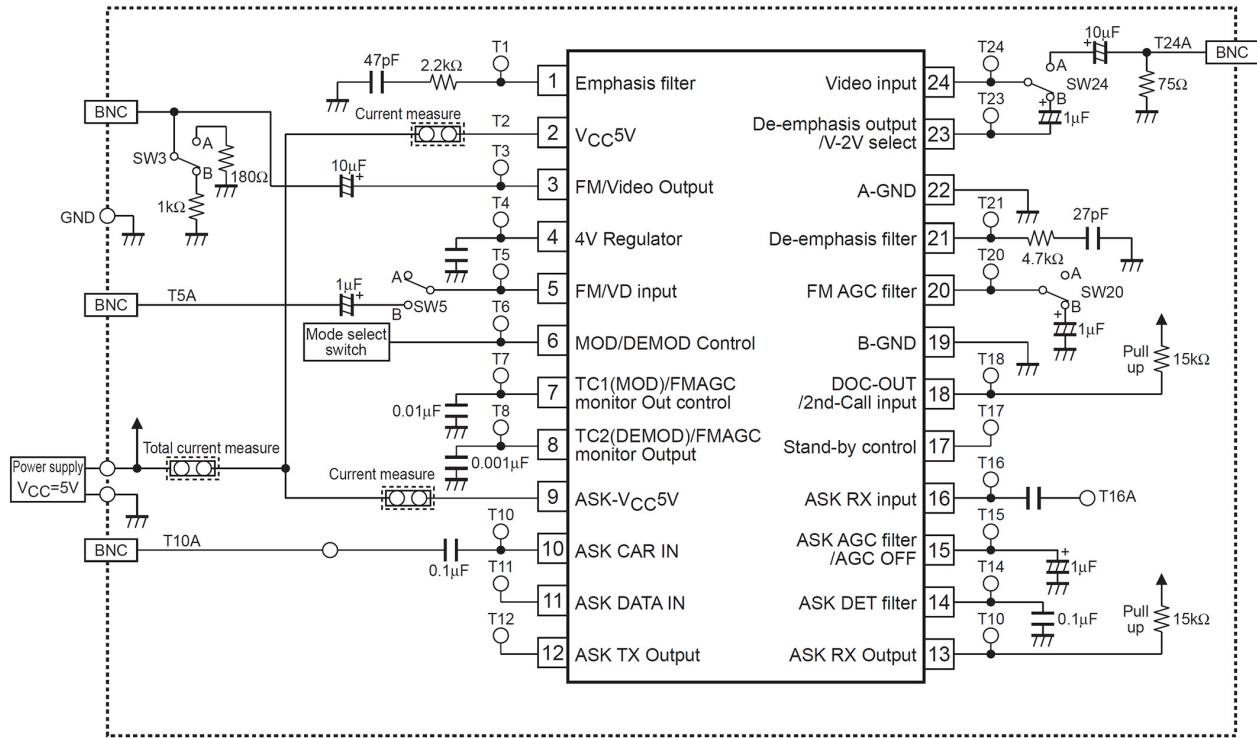

Figure 4. Test Circuit

**MECHANICAL CASE OUTLINE**  
**PACKAGE DIMENSIONS**

ON Semiconductor®



**SSOP24 (275mil)**  
**CASE 565AQ**  
**ISSUE A**

DATE 25 OCT 2013

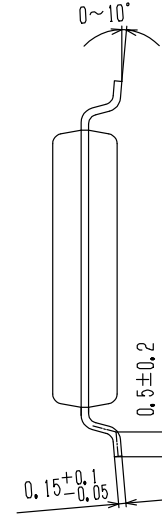
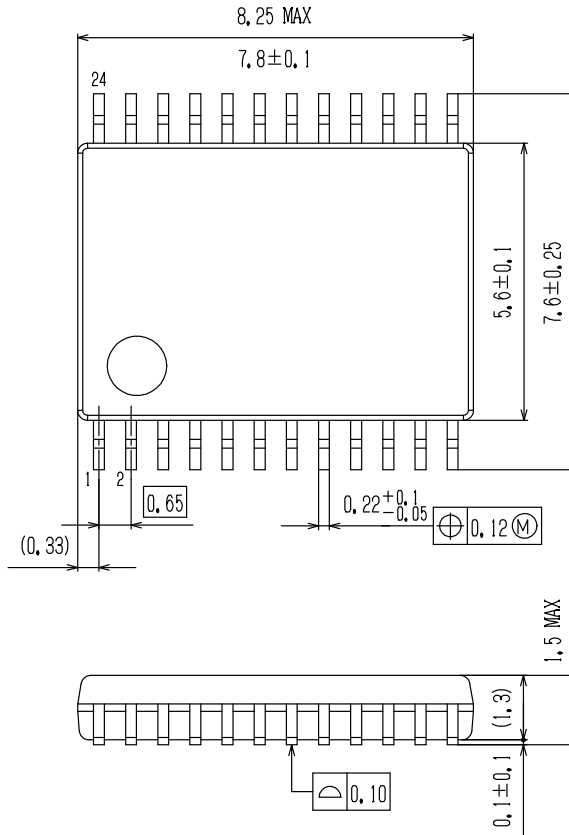
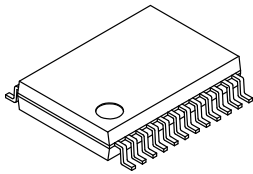

**SOLDERING FOOTPRINT\***

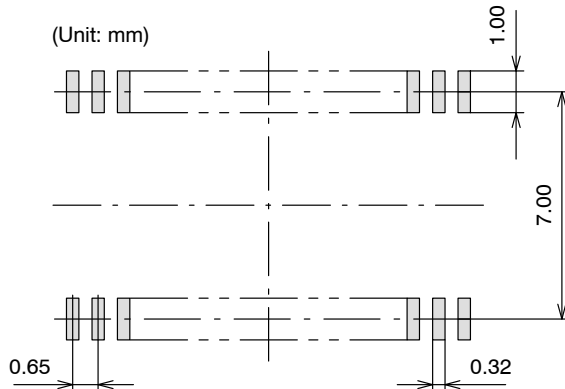

**GENERIC MARKING DIAGRAM\***

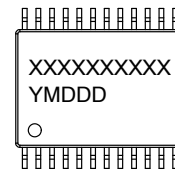

XXXXX = Specific Device Code  
 Y = Year  
 M = Month  
 DDD = Additional Traceability Data

NOTE: The measurements are not to guarantee but for reference only.

\*For additional information on our Pb-Free strategy and soldering details, please download the ON Semiconductor Soldering and Mounting Techniques Reference Manual, SOLDERRM/D.

\*This information is generic. Please refer to device data sheet for actual part marking. Pb-Free indicator, "G" or microdot "▪", may or may not be present.

<b>DOCUMENT NUMBER:</b>	<b>98AON66068E</b>	Electronic versions are uncontrolled except when accessed directly from the Document Repository. Printed versions are uncontrolled except when stamped "CONTROLLED COPY" in red.
<b>STATUS:</b>	<b>ON SEMICONDUCTOR STANDARD</b>	
<b>NEW STANDARD:</b>		
<b>DESCRIPTION:</b>	<b>SSOP24 (275MIL)</b>	<b>PAGE 1 OF 2</b>



ON Semiconductor and  are trademarks of Semiconductor Components Industries, LLC dba ON Semiconductor or its subsidiaries in the United States and/or other countries. ON Semiconductor owns the rights to a number of patents, trademarks, copyrights, trade secrets, and other intellectual property. A listing of ON Semiconductor's product/patent coverage may be accessed at [www.onsemi.com/site/pdf/Patent-Marking.pdf](http://www.onsemi.com/site/pdf/Patent-Marking.pdf). ON Semiconductor reserves the right to make changes without further notice to any products herein. ON Semiconductor makes no warranty, representation or guarantee regarding the suitability of its products for any particular purpose, nor does ON Semiconductor assume any liability arising out of the application or use of any product or circuit, and specifically disclaims any and all liability, including without limitation special, consequential or incidental damages. Buyer is responsible for its products and applications using ON Semiconductor products, including compliance with all laws, regulations and safety requirements or standards, regardless of any support or applications information provided by ON Semiconductor. "Typical" parameters which may be provided in ON Semiconductor data sheets and/or specifications can and do vary in different applications and actual performance may vary over time. All operating parameters, including "Typicals" must be validated for each customer application by customer's technical experts. ON Semiconductor does not convey any license under its patent rights nor the rights of others. ON Semiconductor products are not designed, intended, or authorized for use as a critical component in life support systems or any FDA Class 3 medical devices or medical devices with a same or similar classification in a foreign jurisdiction or any devices intended for implantation in the human body. Should Buyer purchase or use ON Semiconductor products for any such unintended or unauthorized application, Buyer shall indemnify and hold ON Semiconductor and its officers, employees, subsidiaries, affiliates, and distributors harmless against all claims, costs, damages, and expenses, and reasonable attorney fees arising out of, directly or indirectly, any claim of personal injury or death associated with such unintended or unauthorized use, even if such claim alleges that ON Semiconductor was negligent regarding the design or manufacture of the part. ON Semiconductor is an Equal Opportunity/Affirmative Action Employer. This literature is subject to all applicable copyright laws and is not for resale in any manner.

## PUBLICATION ORDERING INFORMATION

### LITERATURE FULFILLMENT:

Literature Distribution Center for ON Semiconductor  
19521 E. 32nd Pkwy, Aurora, Colorado 80011 USA  
**Phone:** 303-675-2175 or 800-344-3860 Toll Free USA/Canada  
**Fax:** 303-675-2176 or 800-344-3867 Toll Free USA/Canada  
**Email:** [orderlit@onsemi.com](mailto:orderlit@onsemi.com)

**N. American Technical Support:** 800-282-9855 Toll Free  
USA/Canada  
**Europe, Middle East and Africa Technical Support:**  
Phone: 421 33 790 2910

**ON Semiconductor Website:** [www.onsemi.com](http://www.onsemi.com)

**Order Literature:** <http://www.onsemi.com/orderlit>

For additional information, please contact your local  
Sales Representative

## Looking for pricing, stock, or lifecycle information?

Click below to explore more details on WIN SOURCE:

 [View LA72912V-TLM-H on WIN SOURCE](#)

 [ON Semiconductor](#) Information

## Optimize Your Supply Chain with WIN SOURCE Solutions

-  Global Sourcing Solution
-  Obsolete Management
-  Cost Control Management
-  Shortage Management
-  Alternative Solution
-  Excess Inventory Management