



THE DATASHEET OF L9958SBTR



Low $R_{DS(ON)}$ SPI controlled H-Bridge

Datasheet - production data

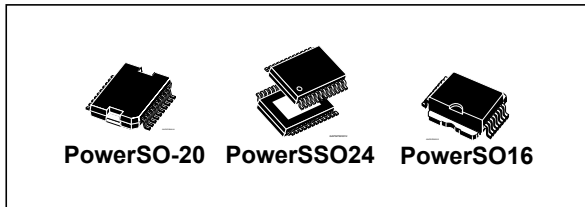

Features

- Programmable current regulation peak threshold by SPI up to 8.6 A typ.
- Operating battery supply voltage 4.0 V to 28 V
- Operating V_{dd} supply voltage 4.5 V to 5.5 V
- All pins withstand 19 V, V_S and output pins withstand 40 V
- Full path R_{on} from 100 m Ω (at $T_j = -40$ °C) to 300 m Ω (at $T_j = 150$ °C)
- Logic inputs TTL/CMOS-compatible
- Operating frequency up to 20 kHz
- 16-bit SPI interface for configuration/diagnostics, daisy chain capability
- Over temperature and short circuit protection
- V_S undervoltage disable function
- V_{dd} undervoltage and overvoltage protection
- V_{dd} overvoltage detection
- Open-load detection in ON condition
- Full diagnostics in OFF state
- Enable and disable input
- Low stand by current (<10 μ A)
- Voltage and current slew-rate control for low EMI, programmable through SPI
- Available in three power packages

Description

The L9958 is an SPI controlled H-Bridge, designed for the control of DC and stepper motors in safety critical applications and under extreme environmental conditions.

The H-Bridge is protected against over temperature, short circuits and has an undervoltage lockout for all the supply voltages V_S and V_{dd} , and for overvoltage on V_{dd} . All malfunctions cause the output stages to go tristate.

Detailed failure diagnostics on each channel is provided via SPI: short circuit to battery, short circuit to ground, short circuit overload, over temperature.

Open-load can be detected in ON condition, for the widest application ranges. Current regulation threshold can be set by SPI from 2.5 A to 8.6 A (Typ.), in 4 steps. Guaranteed accuracy is ± 10 % on all temp range, using an external reference resistor with 1% accuracy over all temp range.

Current limitation threshold is linearly reduced by temperature over 165 °C and a thermal warning bit is set by SPI. The H-Bridge contains integrated free-wheel diodes. In case of free-wheeling condition, the low side transistor is switched on in parallel of its diode to reduce power dissipation.

A multiple wire bonding technique, as well as ST proprietary package design is making L9958 compatible with three power packages, for maximum flexibility:

PowerSO-20 package (medium power, JEDEC standard MO166);

PowerSO16 package (medium power, lower cost);

PowerSSO24 package (low power, very low cost JEDEC standard MO271A).

Table 1. Device summary

| Order code | Package | Packing |
|------------|------------|---------|
| L9958 | PowerSO-20 | Tube |
| L9958SB | PowerSO16 | Tube |
| L9958XP | PowerSSO24 | Tube |

Contents

| | | |
|----------|---|-----------|
| 1 | Block diagram | 6 |
| 2 | Pins description | 7 |
| 2.1 | PowerSO-20 | 7 |
| 2.2 | PowerSO16 | 8 |
| 2.3 | PowerSSO24 | 9 |
| 3 | Device description | 10 |
| 3.1 | Supply range | 10 |
| 3.2 | Control inputs | 10 |
| 3.2.1 | DI and EN inputs | 10 |
| 3.2.2 | DIR and PWM inputs | 11 |
| 3.3 | Serial peripheral interface (SPI) | 12 |
| 3.3.1 | Daisy chain operation | 14 |
| 3.4 | SPI timing | 14 |
| 3.5 | SPI communication failure | 15 |
| 3.6 | 5 V and 3.3 V output compatibility | 15 |
| 4 | Current regulation | 16 |
| 4.1 | Temperature-dependent current regulation | 16 |
| 4.2 | Current regulation with low-inductive loads | 17 |
| 4.3 | Slew rate control in case of current limitation on low-side | 17 |
| 5 | Diagnostics and protections | 19 |
| 5.1 | Diagnosis reset strategy | 19 |
| 5.1.1 | Reset requests | 19 |
| 5.1.2 | Diagnosis reset bit | 19 |
| 5.2 | Protection and on state diagnostics | 20 |
| 5.2.1 | Over-current on high-side - short to ground | 20 |
| 5.2.2 | Over-current on low-side - short to Vs | 20 |
| 5.2.3 | Short circuit over-load | 20 |
| 5.2.4 | Open load in on state | 20 |
| 5.2.5 | Over-temperature | 21 |

| | | |
|----------|--|-----------|
| 5.2.6 | Vs under-voltage shutdown | 21 |
| 5.2.7 | Vdd over-voltage detection | 22 |
| 5.2.8 | Vdd under-voltage detection | 22 |
| 5.2.9 | Output short protection | 22 |
| 5.3 | Off-state diagnosis | 23 |
| 5.3.1 | Off-state detection scheme | 23 |
| 5.3.2 | Open load detection | 23 |
| 5.4 | H-Bridge functional status | 24 |
| 6 | Electrical specifications | 25 |
| 6.1 | Absolute maximum ratings | 25 |
| 6.2 | Thermal data | 25 |
| 6.3 | Range of functionality | 26 |
| 6.4 | Electrical characteristics | 27 |
| 6.4.1 | Device supply | 27 |
| 6.4.2 | Device supply monitoring | 27 |
| 6.4.3 | SPI | 28 |
| 6.4.4 | Digital inputs: TTL // 3.3V / 5V CMOS compatible | 29 |
| 6.4.5 | Bridge output drivers | 29 |
| 6.4.6 | Over-temperature monitoring | 30 |
| 6.4.7 | Current limitation and over-current detection | 30 |
| 6.4.8 | Diagnostic of open-load in on-state | 31 |
| 6.4.9 | Off-state diagnostic | 31 |
| 6.4.10 | Timing characteristics | 32 |
| 7 | Application circuit | 33 |
| 8 | Package information | 34 |
| 9 | Revision history | 37 |

List of tables

| | | |
|-----------|--|----|
| Table 1. | Device summary | 1 |
| Table 2. | PowerSO-20 pin function | 7 |
| Table 3. | PowerSO16 pin function | 8 |
| Table 4. | PowerSSO24 pin function. | 9 |
| Table 5. | Control pins EN, DI | 10 |
| Table 6. | Control pins DIR, PWM. | 11 |
| Table 7. | Configuration protocol (CFG_REG) | 13 |
| Table 8. | Diagnosis protocol (DIA_REG) | 13 |
| Table 9. | Current limitation programmability | 16 |
| Table 10. | Slew rate control on low side MOS | 18 |
| Table 11. | Diagnosis reset strategy | 19 |
| Table 12. | Over-temperature | 21 |
| Table 13. | Vs under-voltage. | 22 |
| Table 14. | Vdd over-voltage detection | 22 |
| Table 15. | Absolute maximum ratings | 25 |
| Table 16. | Thermal data | 25 |
| Table 17. | Range of functionality | 26 |
| Table 18. | Device supply | 27 |
| Table 19. | Device supply monitoring | 27 |
| Table 20. | SPI | 28 |
| Table 21. | Digital inputs: TTL // 3.3V / 5V CMOS compatible | 29 |
| Table 22. | Bridge output drivers. | 29 |
| Table 23. | Over-temperature monitoring | 30 |
| Table 24. | Current limitation and over-current detection | 30 |
| Table 25. | Diagnostic of open-load in on-state | 31 |
| Table 26. | Off-state diagnostic. | 31 |
| Table 27. | Timing characteristics | 32 |
| Table 28. | Document revision history. | 37 |

List of figures

| | | |
|------------|--|----|
| Figure 1. | Block diagram | 6 |
| Figure 2. | PowerSO-20 pin connection (top view) | 7 |
| Figure 3. | PowerSO16 pin connection (top view) | 8 |
| Figure 4. | PowerSSO24 pin connection (top view) | 9 |
| Figure 5. | H-Bridge configurations | 11 |
| Figure 6. | SPI protocol structure | 12 |
| Figure 7. | FSI bit | 12 |
| Figure 8. | Daisy chain topology | 14 |
| Figure 9. | SPI timing | 14 |
| Figure 10. | SPI zero clock communication | 15 |
| Figure 11. | Current limitation | 16 |
| Figure 12. | Temperature dependent current regulation | 17 |
| Figure 13. | Current regulation with different loads | 17 |
| Figure 14. | Slew rate switching strategy | 18 |
| Figure 15. | Diagnostics for SCB / SCOL | 20 |
| Figure 16. | Open load in on state - Low-side current recirculation | 21 |
| Figure 17. | Battery voltage monitoring | 22 |
| Figure 18. | Off-state detection scheme | 23 |
| Figure 19. | Open load detection | 23 |
| Figure 20. | Off-state diagnostic principle | 24 |
| Figure 21. | Thermal impedance (junction-ambient) of power packages | 26 |
| Figure 22. | Application circuit | 33 |
| Figure 23. | PowerSO-20 mechanical data and package dimensions | 34 |
| Figure 24. | PowerSO16 mechanical data and package dimensions | 35 |
| Figure 25. | PowerSSO24 mechanical data and package dimensions | 36 |

1 Block diagram

Figure 1. Block diagram

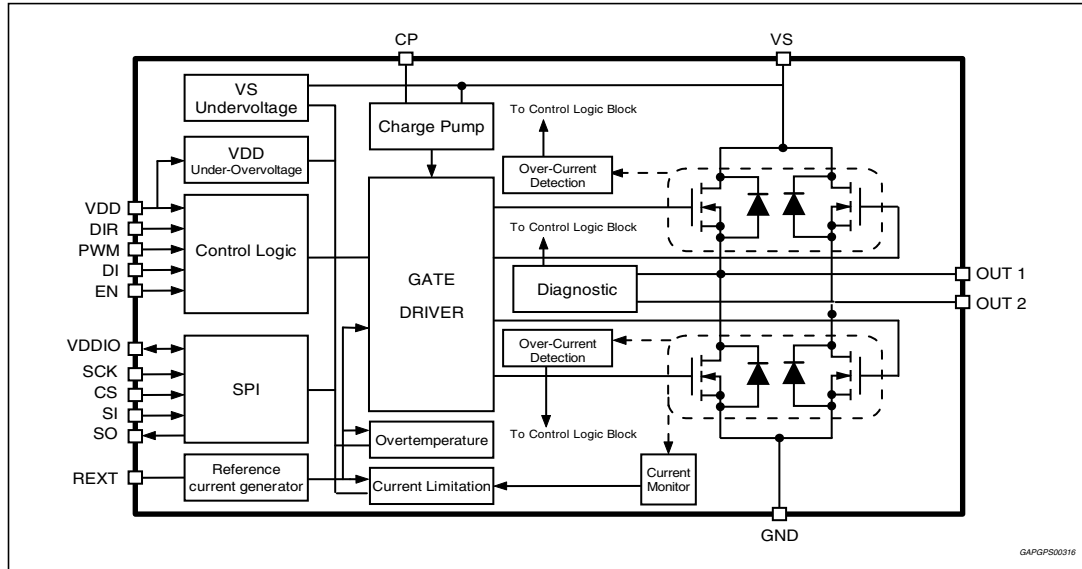

2 Pins description

2.1 PowerSO-20

The exposed slug must be soldered on the PCB and connected to GND.

Table 2. PowerSO-20 pin function

| Pin N° | Name | Description |
|--------|-------|---|
| 1 | GND | Ground |
| 2 | SO | Serial out |
| 3 | VDDIO | Supply voltage for SPI |
| 4 | CS | Chip select |
| 5 | CP | Charge pump |
| 6 | VS | Supply voltage |
| 7 | DIR | Direction input |
| 8 | OUT1 | Output 1 |
| 9 | DI | Disable |
| 10 | GND | Ground |
| 11 | GND | Ground |
| 12 | EN | Enable |
| 13 | OUT2 | Output 2 |
| 14 | PWM | PWM input |
| 15 | REXT | External reference resistor |
| 16 | SI | Serial in |
| 17 | SCK | SPI clock |
| 18 | VDD | Supply voltage |
| 19 | N.C. | Not connected (To be connected to GND on the PCB) |
| 20 | GND | Ground |

Figure 2. PowerSO-20 pin connection (top view)

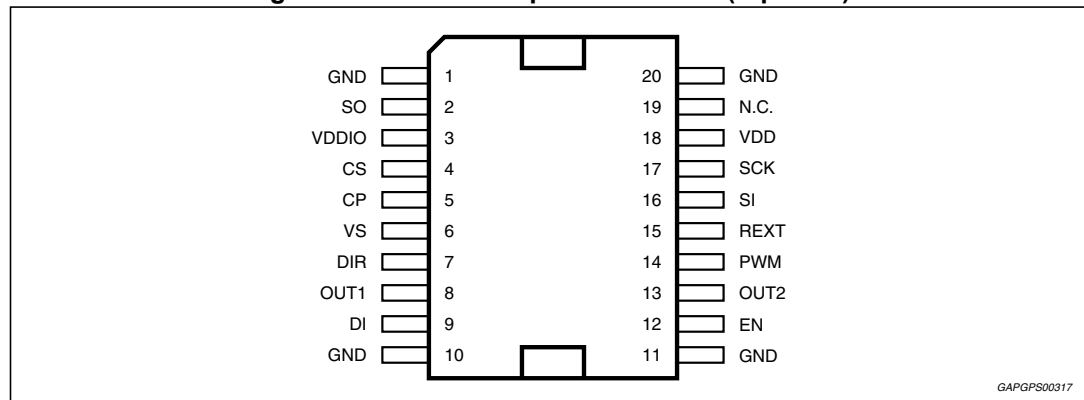

2.2 PowerSO16

The exposed slug must be soldered on the PCB and connected to GND

Table 3. PowerSO16 pin function

| Pin N° | Name | Description |
|--------|------|-----------------------------|
| 1 | GND | Ground |
| 2 | SO | Serial Out |
| 3 | CS | Chip Select |
| 4 | CP | Charge pump |
| 5 | DIR | Direction Input |
| 6 | OUT1 | Output 1 |
| 7 | DI | Disable |
| 8 | PGND | Power Ground |
| 9 | EN | Enable |
| 10 | OUT2 | Output 2 |
| 11 | PWM | PWM Input |
| 12 | REXT | External Reference Resistor |
| 13 | VS | Supply Voltage |
| 14 | SI | Serial In |
| 15 | SCK | SPI Clock |
| 16 | VDD | Supply Voltage |

Figure 3. PowerSO16 pin connection (top view)

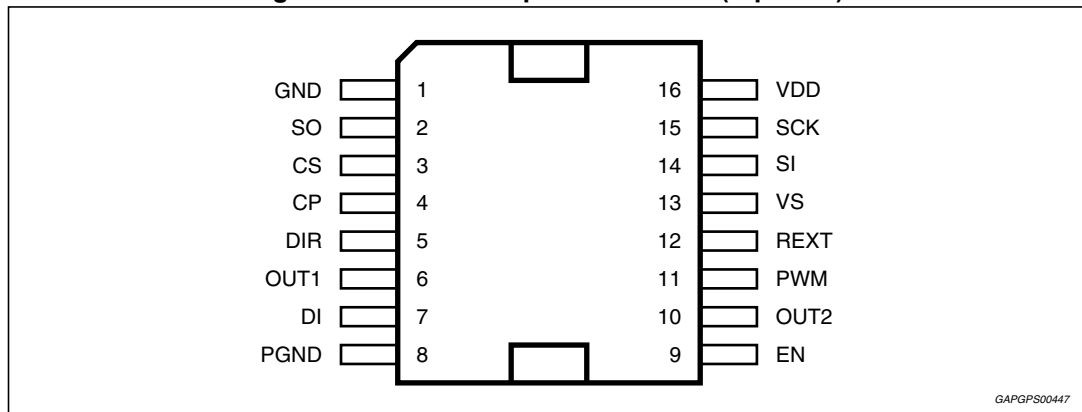

GAPGPS00447

2.3 PowerSSO24

Although this package has two separate pins for the ground (pin 11 = PGND = Power Ground and pin 22 = GND = Logic Ground), the device is designed to work with shortening ground and is mandatory that the two pins have to be connected nearby the IC on the PCB.

The exposed slug must be soldered on the PCB and connected to GND.

Table 4. PowerSSO24 pin function

| Pin N° | Name | Description |
|-----------------------------|-------|-----------------------------|
| 1, 2, 12, 13, 14, 23, 24 | N.C. | Not Connected |
| 3 | SO | Serial Out |
| 4 | VDDIO | Supply Voltage for SPI |
| 5 | CS | Chip Select |
| 6 | CP | Supply Voltage for SPI |
| 7 | VS | Supply Voltage |
| 8 | DIR | Direction Input |
| 9 | OUT1 | Output 1 |
| 10 | DI | Disable |
| 11 | PGND | Power Ground |
| 15 | EN | Enable |
| 16 | OUT2 | Output 2 |
| 17 | PWM | PWM Input |
| 18 | REXT | External Reference Resistor |
| 19 | SI | Serial In |
| 20 | SCK | SPI Clock |
| 21 | VDD | Supply Voltage |
| 22 | GND | Ground |

Figure 4. PowerSSO24 pin connection (top view)

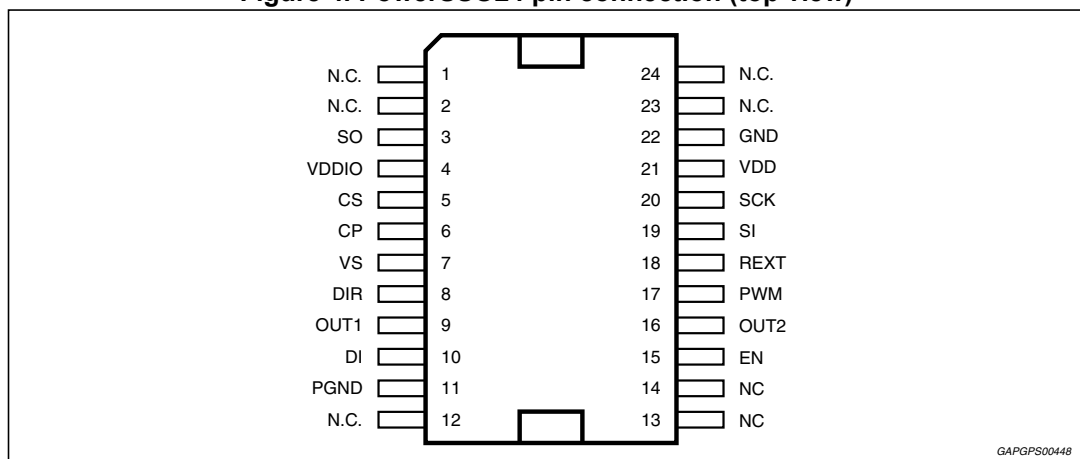

3 Device description

3.1 Supply range

The L9958 has an operating supply range from "Vs_uv" (battery monitoring) up to 28 V. However, the device is tested until 16 V; the functionality of the device is guaranteed until 28 V. The absolute maximum rating is defined to 40 V DC.

3.2 Control inputs

The bridge is controlled by the Inputs PWM, DIR, EN and DI.

All the digital inputs and outputs of the L9958 are compatible with 3.3 V and 5 V CMOS. The power stages output OUT1 and OUT2 are controlled by the direct inputs DIR and PWM as given in [Table 5](#). The DIR input gives the direction of output current, while the PWM input controls whether the current is increased or reduced.

3.2.1 DI and EN inputs

The pin DI is internally pulled-up and high active. When DI is active (set to HIGH), the bridge is set to tristate, whatever the state of the DIR and PWM inputs. All the data stored in SPI registers are not reset and SPI communication with the MCU is still possible. When DI is inactive (set to LOW), the bridge is controlled by the DIR and PWM inputs.

The pin EN is internally pulled down and high active. When EN is inactive (set to LOW), the bridge is set to tri-state, whatever the state of the DIR and PWM inputs. All the data stored in SPI registers are not reset and SPI communication with the MCU is still possible. When EN is active (set to HIGH), the bridge is controlled by the DIR and PWM inputs. The coding is performed as shown in the next table. The state of the bridge is transferred in the diagnostic register in a bit called "ACT".

Table 5. Control pins EN, DI

| EN | DI | Bit "ACT" | Bridge status |
|----|----|-----------|---------------|
| 0 | 0 | 0 | Tri-state |
| 0 | 1 | 0 | Tri-state |
| 1 | 0 | 1 | On-state |
| 1 | 1 | 0 | Tri-state |

3.2.2 DIR and PWM inputs

The pins DIR and PWM are internally pulled down. The bridge is controlled by these two inputs according to the table below.

Table 6. Control pins DIR, PWM

| DIR | PWM | OUT1 | OUT2 | Bridge Status |
|-----|-----|------|------|------------------|
| H | H | H | L | Forward |
| L | L | L | L | Freewheeling Low |
| L | H | L | H | Reverse |
| H | L | L | L | Freewheeling low |

Figure 5. H-Bridge configurations

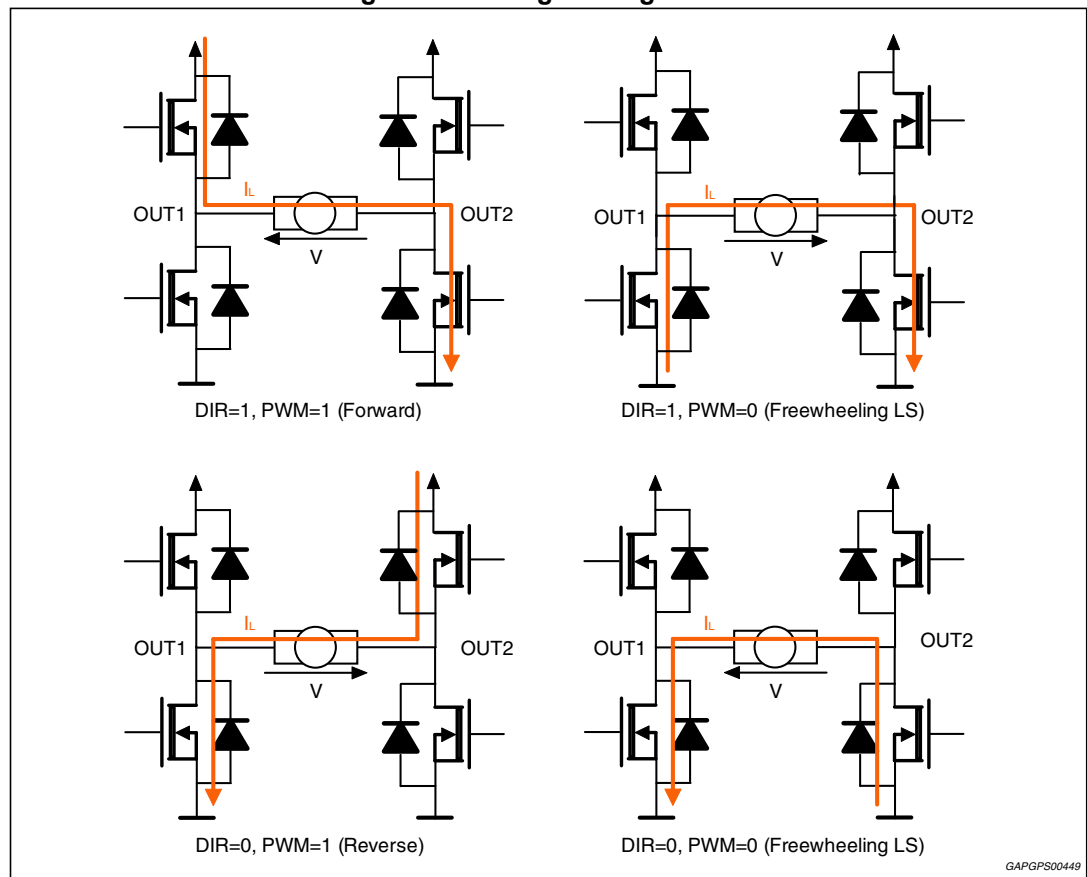

The outputs can be disabled (set to tri-state) by the Disable and Enable inputs DI and EN. Input DI has an internal pull-up. Input EN has an internal pull-down. During freewheeling phase, an active freewheeling on the Low-Side MOS is automatically set, switching ON the power transistor in parallel to the internal freewheeling diode.

3.3 Serial peripheral interface (SPI)

The SPI is used for bidirectional communication with a control unit, allowing IC configuration, diagnosis and identification. L9958 can also be used in daisy-chain configuration (number of device in the daisy chain is not limited).

The SPI interface of L9958 is a slave SPI interface: the master is the μC which provides CS and SCK to L9958.

Transfer format uses 16 bits word in case of single device configuration and multiple of 16 bits word in case of daisy chain configuration.

The first answer after Power-ON-Reset is the IC identifier.

A command sent by the μC during transfer N is answered during transfer N+1. SO is clocked on SCK rising edge. SI is sampled on falling edge. When CS = '1' and during power-ON reset, SO is in tri-state. Otherwise, the SPI interface is always active.

Settings made by the SPI control word become active at the end of the SPI transmission and remain valid until a different control word is transmitted or a power on reset occurs.

At each SPI transmission, the diagnosis bits as currently valid in the error logic are transmitted. Details on diagnosis are described in [Section 5](#).

Figure 6. SPI protocol structure

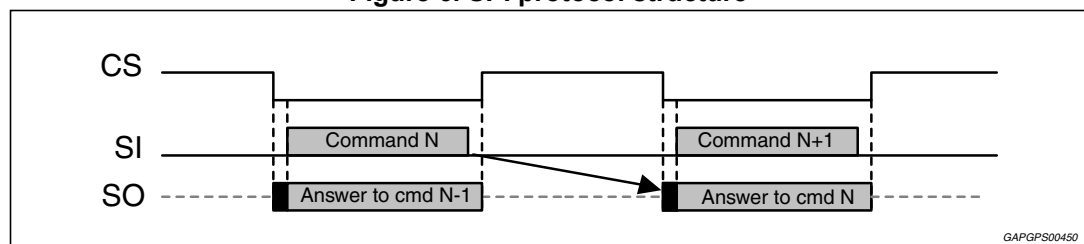

Between CS falling edge and SCK rising edge, an internal signal called "FSI bit" is set asynchronously on SO output. This can be useful to have internal information on the device without stimulating the SCK clock. The definition of the FSI bit is presented in the diagnostics chapter.

Figure 7. FSI bit

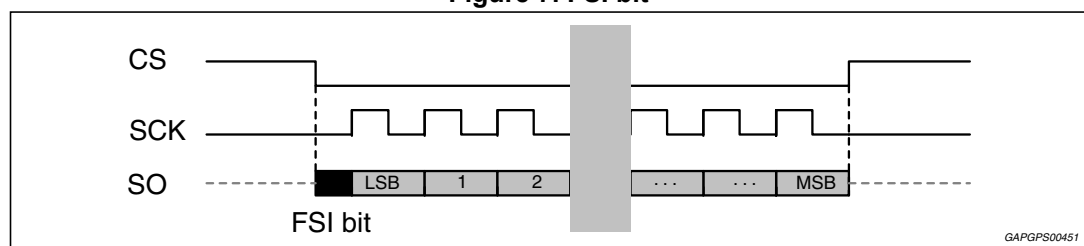

Except the Enable / Disable bit ("ACT" pin), all the bits of diagnosis register are latched and can be released by:

- Diagnosis register read by SPI
- Power-On-Reset condition.

The coding for the Configuration and Diagnosis Registers is reported in the table below.

Table 7. Configuration protocol (CFG_REG)

| Bit | Name | Description | Config. value after reset |
|---------|---------|-----------------------------------|---------------------------|
| 0 - LSB | RES | Reserved | — |
| 1 | DR | Diagnostic Reset Bit | 0 |
| 2 | CL_1 | Bit1 for Regulation Current Level | 0 |
| 3 | CL_2 | Bit2 for Regulation Current Level | 1 |
| 4 | RES | Reserved | — |
| 5 | RES | Reserved | — |
| 6 | RES | Reserved | — |
| 7 | RES | Reserved | — |
| 8 | VSR | Voltage Slew Rate Control Value | 0 |
| 9 | ISR | Current Slew Rate Control Value | 0 |
| 10 | ISR_DIS | Current Slew Rate Control Disable | 0 |
| 11 | OL_ON | Open Load in ON state Enable | 0 |
| 12 | RES | Reserved | — |
| 13 | RES | Reserved | — |
| 14 | 0 | "0" to be written | — |
| 15-MSB | 0 | "0" to be written | — |

Table 8. Diagnosis protocol (DIA_REG)

| Bit | Name | Description | Status after reset | Bit state | DR impact | H-bridge status |
|--------|----------|-----------------------------------|--------------------|-------------|-----------|-----------------|
| 0-LSB | OL_OFF | Open Load in OFF condition | 0 | Latched | — | — |
| 1 | OL_ON | Open Load in ON condition | 0 | Latched | — | — |
| 2 | VS_UV | Vs undervoltage | 0 | Not latched | — | Hi-Z if "1" |
| 3 | VDD_OV | Vdd overvoltage | 0 | Latched | X | Hi-Z if "1" |
| 4 | ILIM | Current Limitation reached | 0 | Latched | — | — |
| 5 | TWARN | Temperature warning | 0 | Latched | — | — |
| 6 | TSD | Over-temperature Shutdown | 0 | Latched | X | Hi-Z if "1" |
| 7 | ACT | Bridge enable | 1 | Not latched | — | Hi-Z if "0" |
| 8 | OC_LS1 | Over-Current on Low Side 1 | 0 | Latched | X | Hi-Z if "1" |
| 9 | OC_LS2 | Over-Current on Low Side 2 | 0 | Latched | X | Hi-Z if "1" |
| 10 | OC_HS1 | Over-Current on High Side 1 | 0 | Latched | X | Hi-Z if "1" |
| 11 | OC_HS2 | Over-Current on High Side 2 | 0 | Latched | X | Hi-Z if "1" |
| 12 | Null | Not Used | — | — | — | — |
| 13 | Null | Not Used | — | — | — | — |
| 14 | SGND_OFF | Short to GND in OFF condition | 0 | Latched | — | — |
| 15-MSB | SBAT_OFF | Short to Battery in OFF condition | 0 | Latched | — | — |

3.3.1 Daisy chain operation

Several L9958 can be connected to one SPI connection in daisy chain operation to save μC interface pins. The number of devices connected in daisy chain is unlimited.

Figure 8. Daisy chain topology

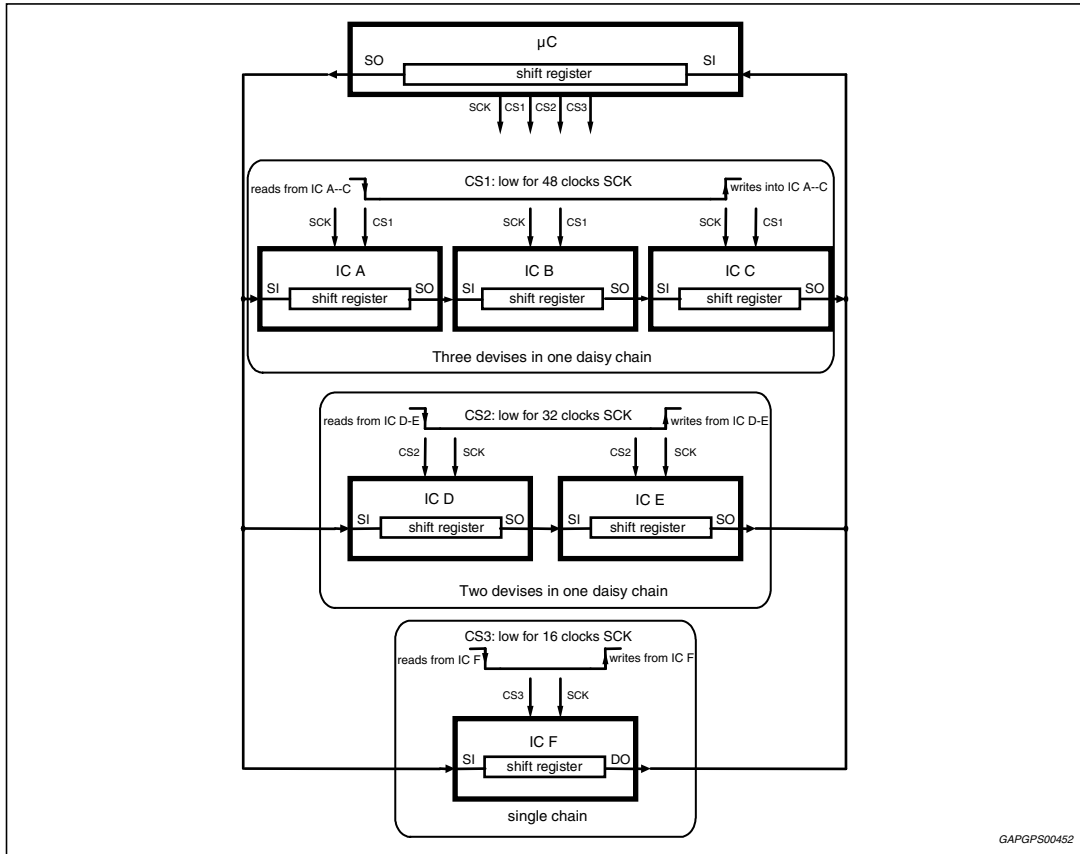

GAPGPS00452

3.4 SPI timing

Figure 9. SPI timing

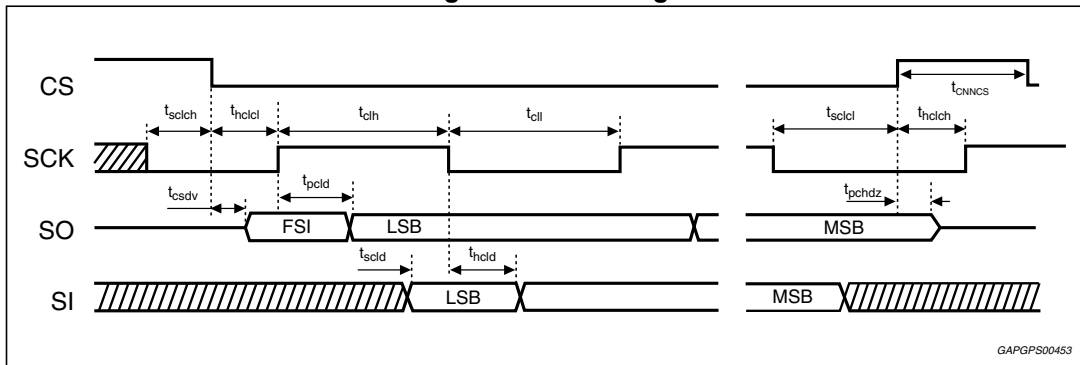

GAPGPS00453

3.5 SPI communication failure

In case of "no SCK edge" when CS = '0', the transfer is considered as valid: no error is returned to the μ C. The answer of last command is sent during next transfer.

When the number of SCK period is different from 0 or multiple of 16, next SPI answer is all zero.

Figure 10. SPI zero clock communication

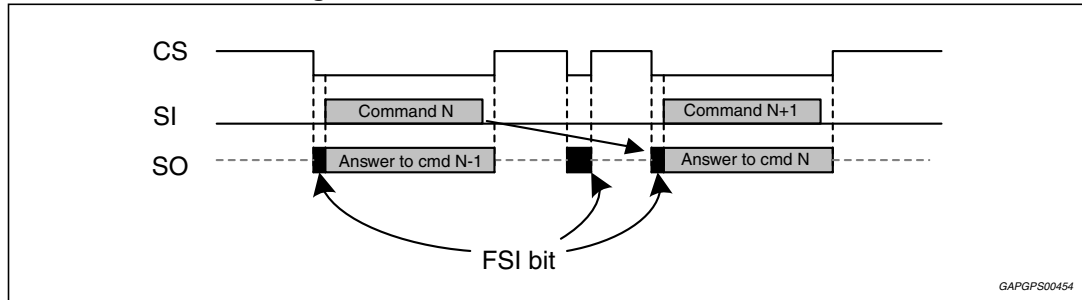

3.6 5 V and 3.3 V output compatibility

In order to ensure a full compatibility with 5V and 3.3V MCU peripherals, the pin VDDIO is dedicated to supply the output buffer of SO. The overall current consumption on Vddio is "Ivddio". A parasitic current from the pin SO could flow through the pin VDDIO in case of over-voltage on SO pin vs. VDDIO pin.

4 Current regulation

To protect the actuator and limit power dissipation, a two-level chopper current limitation is integrated as shown in figure below. The current is measured by sense cells integrated in the low-side switches. As soon the upper current limit “IH” is reached, both low-side drivers are switched on to allow free-wheeling recirculation, until the lower current limit “IL” is reached. During the current regulation, all the slew rate controls are disabled in order to minimize the power dissipation. Four current limit levels can be set by the SPI control bits 0 and 1. In order to achieve very precise current threshold and ripple, an external resistance is required (1 % accuracy on all temp range/lifetime) to generate a current reference. Detailed values for current thresholds and ripple are reported in [Table 9](#).

Figure 11. Current limitation

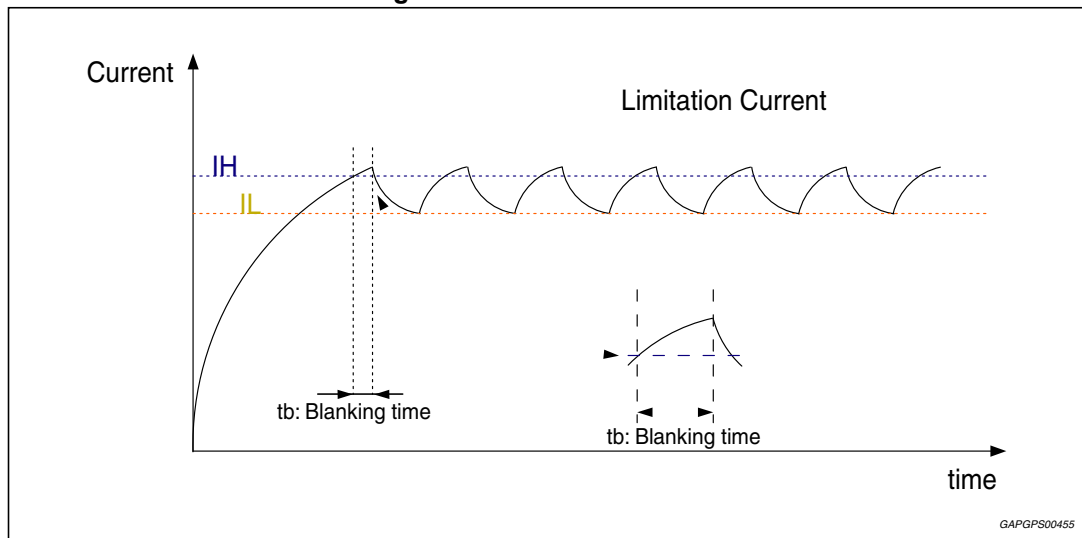

Table 9. Current limitation programmability

| CL_2 | CL_1 | Current limit (typical values) |
|------|------|--------------------------------|
| 0 | 0 | 2.5 A |
| 0 | 1 | 4 A |
| 1 | 0 | 6.6 A (default value) |
| 1 | 1 | 8.6 A |

4.1 Temperature-dependent current regulation

In order to reduce power dissipation and thus the junction temperature, above a temperature $T_{warn} = 160\text{ °C}$, current regulation high limit linearly decreases with temperature, to reach about 2.5 A at $T_{sd} = 175\text{ °C}$ (shutdown temperature).

When this thermal threshold is reached during a current limitation phase, the information is stored and latched in a coding of bits called "Twarn". This bit can be reset only if the settings conditions ($T_j > T_{warn}$ and $I_{LIM} = 0$) are not present anymore. This feature is mainly used to reduce the power dissipation and thus the junction temperature.

Figure 12. Temperature dependent current regulation

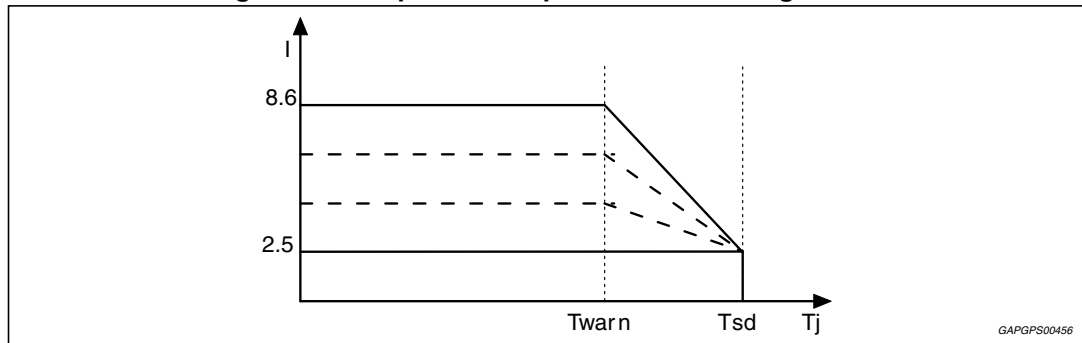

4.2 Current regulation with low-inductive loads

Each time output stages are turned off, an internal timing starts for duration **Toff-min**. Whenever turn-on is reached in a time **Toff** that is shorter than **Toff-min**, output stages are kept OFF, until **Toff-min** is reached.

In such case the ripple control could be not so precise as specified.

Figure 13. Current regulation with different loads

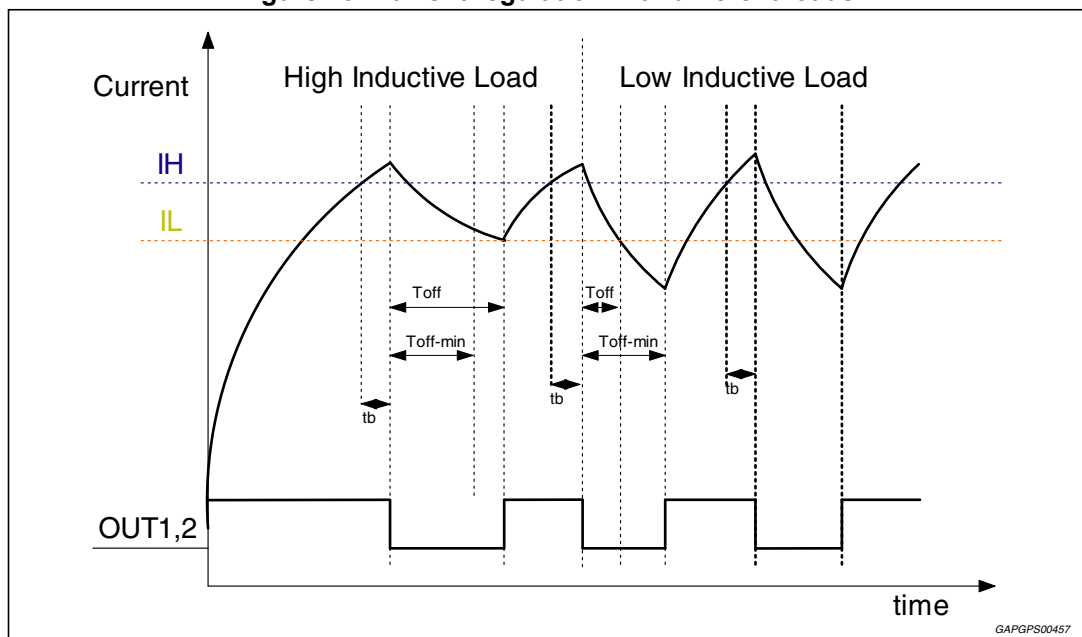

4.3 Slew rate control in case of current limitation on low-side

The slew rate control can be done on voltage and current or only on voltage. This can be selected by SPI through the bit **ISR_DIS**.

The slew rate of each high-side power transistor of the bridge is controlled either during turn-on and turn-off (current AND voltage slew rate). The same setting is applied for both switching. Moreover, this slew rate is configurable by SPI in order to get the best trade-off between conducted/radiated EMI and power dissipation during switching. The slew rate

selection can be done "on the fly" by SPI. The corresponding bits are called "VSR" and "ISR". No external component is needed to select the slew rate range. Only the power transistors not used for freewheeling can be adjusted, the two others can be controlled with a preset slew rate.

The couples of value defined to fulfill most of the application requirements are described in the table below. The required accuracy is $\pm 50\%$ for an output current from 1A to 8A and with output voltage up to 19 V. The overall delay implemented between high-side and low-side transistor switching must be adjusted automatically to avoid any cross-conduction through one half-bridge in all conditions.

Table 10. Slew rate control on low side MOS

| Range | VSR | ISR | dV/dt (V/ μ s) | dI/dt (A/ μ s) |
|-------------------|----------------|-----|--------------------|--------------------|
| 1 (default value) | 0 | 0 | 4 | 3 |
| 2 | 0 | 1 | 4 | 0.3 |
| 3 | 1 | 0 | 2 | 3 |
| 4 | 1 | 1 | 2 | 0.3 |
| No SR control | Not selectable | | 14 | 14 |

In case of current limitation and any detection that put the bridge in tri-state, the slew rate is not related anymore to the preset bits "VSR"; "ISR" but to a dedicated faster slew rate control named "SUPER FAST" mode. The automatic change from SPI selectable to SUPER FAST slew rate is described hereafter.

Figure 14. Slew rate switching strategy

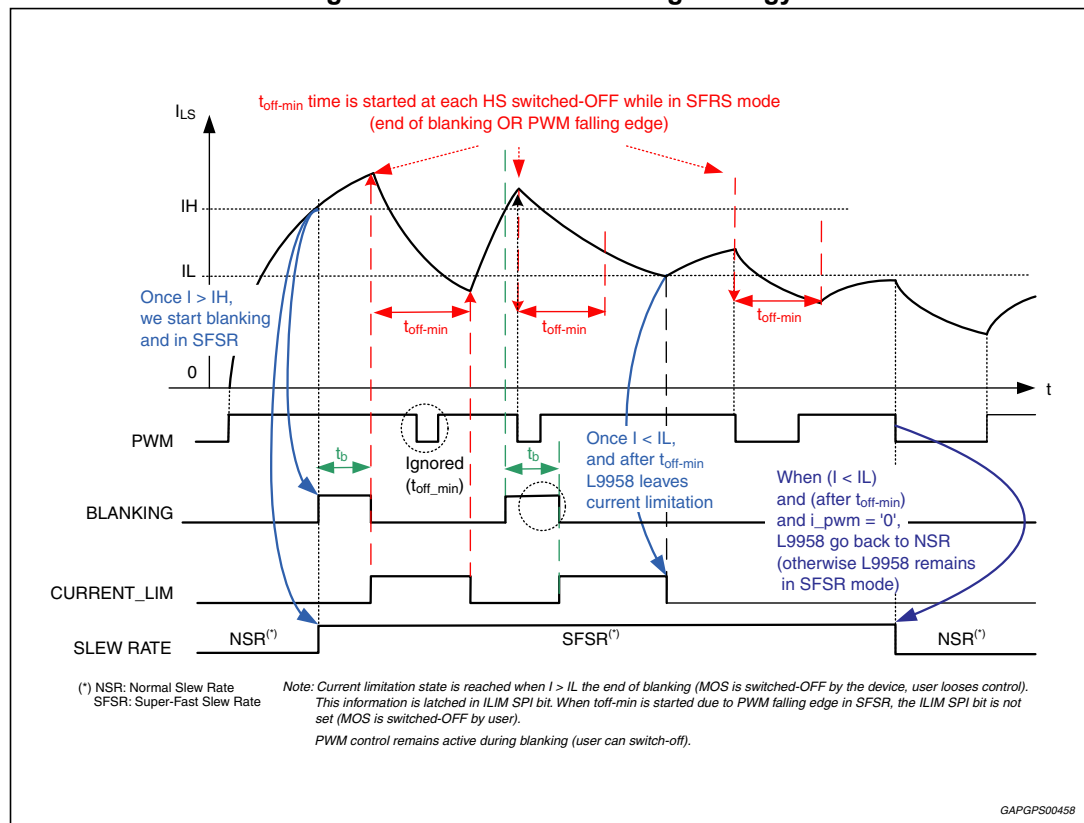

5 Diagnostics and protections

A detailed diagnostic of the H-bridge is available through SPI communication. The 16 bits diagnostic word is sent back to the MCU in return of a command word. The diagnostic word is used to report two kinds of information:

- H-Bridge failures:
 - Over-current on each transistor in on-state,
 - Vps under-voltage,
 - Vdd over-voltage,
 - Over-temperature,
 - Open-load in on-state,
 - Off-state diagnostic.
- H-bridge functional status:
 - Current limitation condition,
 - Current limitation decreasing condition,
 - Disable / Enable status.

5.1 Diagnosis reset strategy

5.1.1 Reset requests

Except "ACT" and "VS_UV" bits, all the others are latched and can only be released by:

- Transition from "Disable" to "Enable" on DI / EN pins,
- Diagnostic register read by SPI (see details on each failure release) depending on bit "DR",
- Power-On-Reset condition.

When the diagnostic register is reset, the bridge is switched back to normal mode driven by DIR and PWM. All the settings are kept as before the failure. In case of SPI read, no additional action on DI / EN is needed.

5.1.2 Diagnosis reset bit

In case of "DR" set to LOW (default value), all the bits of the diagnostic register can be reset by the three possibilities described in previous section.

In case of "DR" set to HIGH, the over-current, Vdd over-voltage and over-temperature diagnostic bits can NOT be reset by SPI read and therefore, the bridge is kept in tri-state until a transition from "Disable" to "Enable" on DI/EN pins or Power-on-Reset condition.

Table 11. Diagnosis reset strategy

| DR | Diagnosis reset strategy |
|----|--|
| 0 | All diagnostic bits reset at each SPI reading (Default) |
| 1 | Over current bits (8..11) + Temp. shutdown TSD bit (6) + Vdd over voltage bit (3) NOT reset by SPI |

5.2 Protection and on state diagnostics

L9958 is protected against short circuits, overload and invalid supply voltage by the following measures.

5.2.1 Over-current on high-side - short to ground

The high-side switches are protected against a short of the output to ground by an over-current shutdown. If a high-side switch is turned on and the current rises above the short circuit detection current I_{oc} all output transistors are turned off after a filter time T_{oc_Is} and the error bits "overcurrent on high side 1 (2)", **OC_HS1 (OC_HS2)** are stored in the internal status register.

5.2.2 Over-current on low-side - short to Vs

Due to the chopper current regulation, the low-side switches are already protected against a short to the supply voltage. To be able to distinguish a short circuit from normal current limit operation, the current limitation is deactivated for the blanking time t_b after the current has exceeded the current limit threshold I_H . If the short circuit detection current I_{oc} is reached within this blanking time, a short circuit is detected. All output transistors are turned OFF and the according error bit "Over-Current on Low Side 1 (2)", **OC_LS1 (OC_LS2)** is set.

5.2.3 Short circuit over-load

If, during the Blanking time (t_b) of the current regulation mode, the current reaches the I_{oc} threshold; after a filtering time, the output MOS are switched OFF and the "Short circuit over load" can be checked by the reading of the overcurrent bits of the DIA_REG (please refer to [Table 8](#) bit 8, 9,10 and 11).

Figure 15. Diagnostics for SCB / SCOL

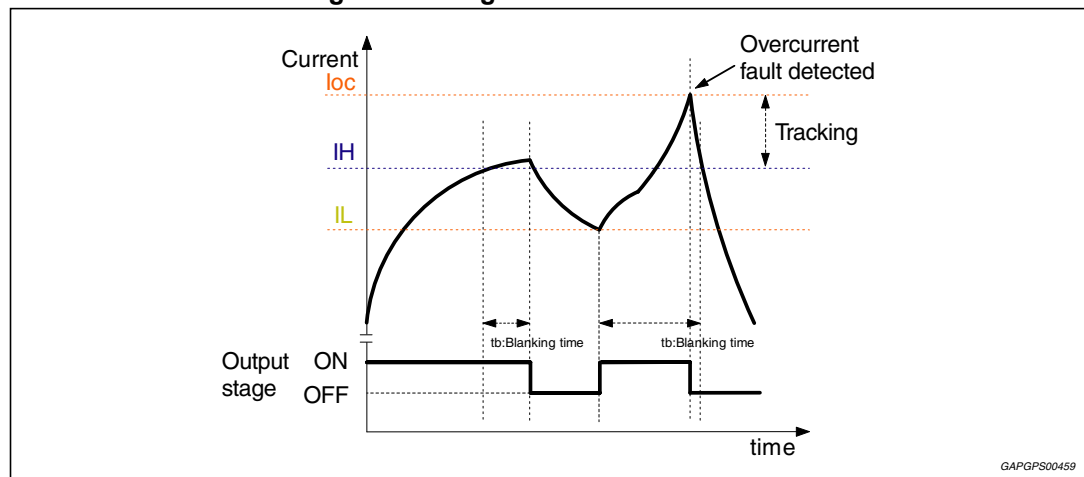

5.2.4 Open load in on state

To perform the Open Load diagnosis in ON state, the flag **OL_ON** has to be set high through SPI. After every open load diagnosis in ON state, the **OL_ON** flag is resetted, to perform a new open load diagnosis in ON state the **OL_ON** flag has to be set again.

This disable the turning on of the low-side drivers during current recirculation. The current flows through the body diode of the low-side MOS for a fixed time. At the end of this fixed time the Vout voltage is sampled and the possible open load condition detected (see Figure 16).

Figure 16. Open load in on state - Low-side current recirculation

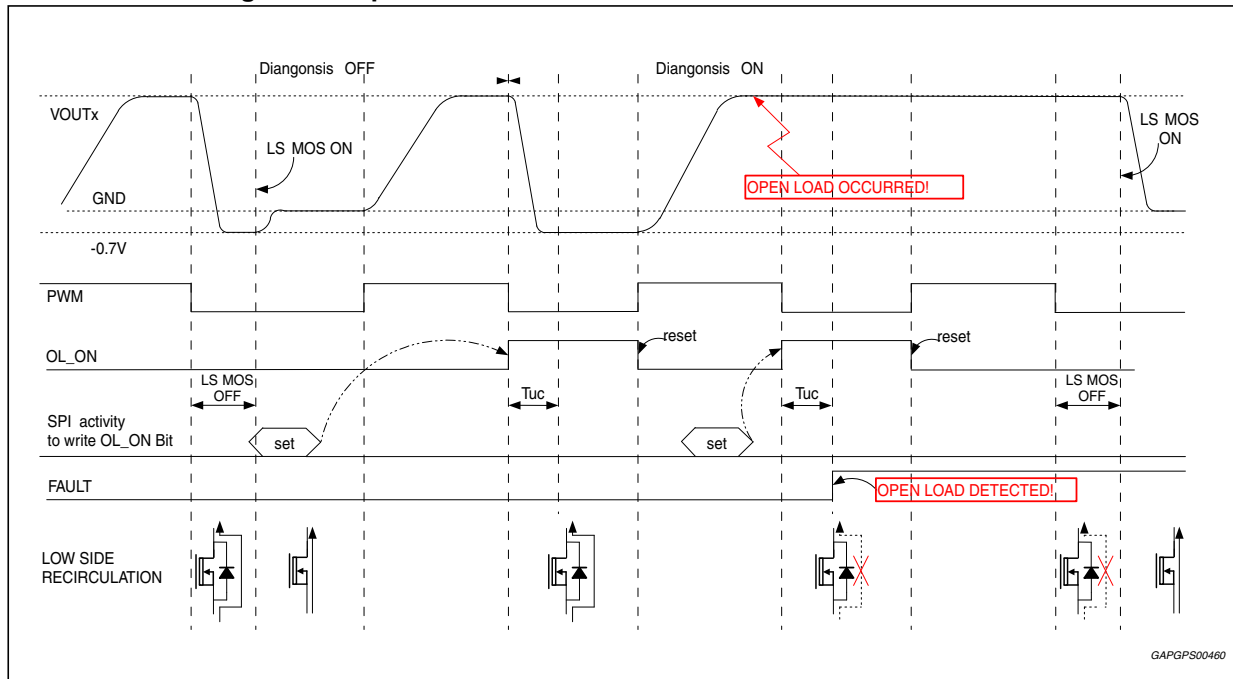

5.2.5 Over-temperature

When T_{warn} is reached, thermal current reduction is activated, and the information is stored and latched. When T_{sd} is reached, the "TSD" bit is set and all output transistors are put in tri-state conditions as long as a reset is applied.

Table 12. Over-temperature

| TSD | Comments | Bridge state | FSI |
|-------------|----------------|--------------|-----|
| 1 | $T_j > T_{SD}$ | Tri-state- | 1 |
| 0 (default) | $T_j < T_{SD}$ | - | 0 |

5.2.6 Vs under-voltage shutdown

If the supply-voltage at the V_S pins falls below the under-voltage detection threshold $V_{s_uv_off}$, the outputs are set to tri-state and the error bit "Undervoltage at V_S " is set. A filtering time " T_{uv_Vs} " is implemented to avoid unwanted detection due to parasitic glitches. The information is transferred into the SPI register in a bit called " V_{S_UV} ". This bit is NOT latched. As soon as the voltage rises again above the V_S under-voltage threshold (hysteresis implemented), the bridge is switched back to normal mode driven by DIR and PWM. All the settings are kept as before the under-voltage event.

Figure 17. Battery voltage monitoring

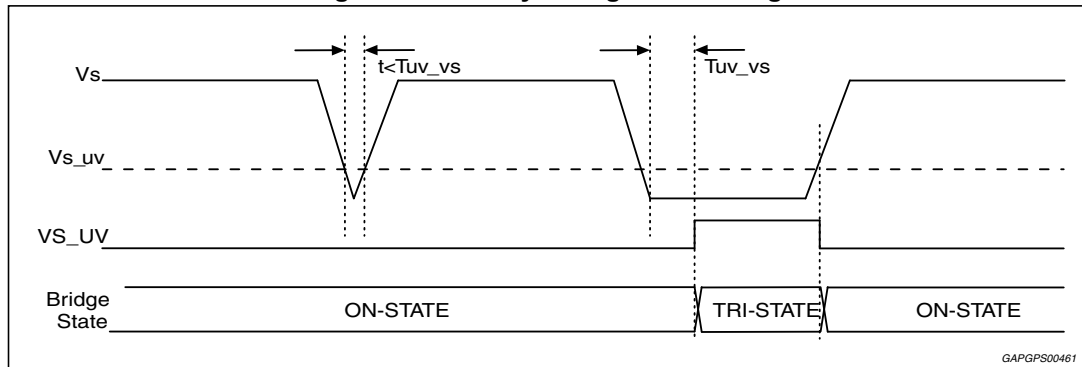

Table 13. Vs under-voltage

| VS_UV | Comments | Bridge state | FSI |
|-------------|------------------------|--------------|-----------------|
| 1 | $V_s < V_{s_uv_off}$ | Hi Z | 1 (not latched) |
| 0 (default) | $V_s > V_{s_uv_on}$ | - | 0 |

5.2.7 Vdd over-voltage detection

Although the Vdd input pin and all I/O's are able to withstand up to 19 V, an over-voltage circuitry is implemented to ensure that the bridge is kept in tri-state when the Vdd voltage is higher than the Vdd overvoltage threshold "**Vdd_ov_off**" for duration longer than "**Tov_Vdd**". The information is detected and stored into the SPI register in a bit called "**VDD_OV**". The bridge is kept in tri-state as long as an appropriate reset is not requested (see [Section 5.1](#)).

Table 14. Vdd over-voltage detection

| VDD_OV | Comments | Bridge state | FSI |
|-------------|----------------------------|--------------|-------------|
| 1 | $V_{dd} > V_{dd_ov_off}$ | Hi-Z | 1 (latched) |
| 0 (default) | $V_{dd} < V_{dd_ov_on}$ | - | 0 |

5.2.8 Vdd under-voltage detection

When the Vdd voltage falls below the under-voltage detection threshold "**Vdd_uv_off**" for duration longer than "**Tuv_vdd**", the bridge is switched to tri-state. In such a condition, the L9958 is going in sleep mode. When the voltage increases above the threshold (hysteresis implemented), the L9958 starts with all the settings reset to their default values (Power On Reset).

5.2.9 Output short protection

The L9958 can sustain short on the outputs. In case of short to GND, short to battery or short between outputs the battery voltage cannot exceed 18 V. The connection of a 100 μ F plus a 1 μ F decoupling capacitors as close as possible to V_s pin and the GND connection of the slug or of the exposed pad is mandatory to improve the robustness.

5.3 Off-state diagnosis

This diagnostic is performed in any off-state condition, just after ignition key-on or during an off-state phase occurring after an on-state phase of the bridge.

5.3.1 Off-state detection scheme

In order to avoid any wrong diagnostic, a filtering time "Tdiag_off" is applied before performing the detection if the bridge was in on-state before. This filtering time is not applied in case of detection after key on.

Figure 18. Off-state detection scheme

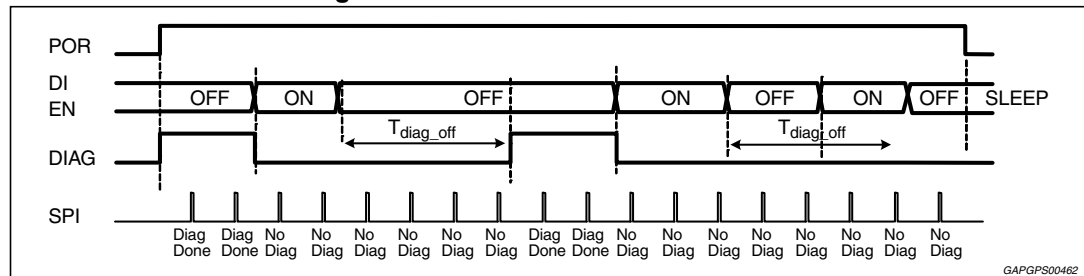

5.3.2 Open load detection

An equivalent resistor of 100 kΩ (typ.) is targeted for open-load detection.

In order to avoid any unwanted supply of the bridge through the high-side transistor body diode during off-state measurement, the current source is connected only if V_s is higher than the V_s under-voltage threshold.

Figure 19. Open load detection

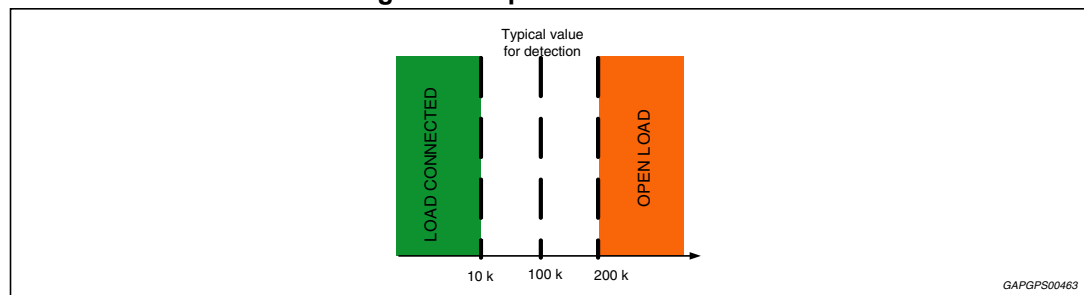

The diagnostic is based on a closed loop voltage control on OUT1 and associated current measurement.

A voltage amplifier forces a constant voltage on OUT1 through two current sources (high-side source and low-side current sink). The OUT2 is pulled-down through a constant current sink. Based on the current flowing out of the amplifier (I_p – I_n) compared to several current thresholds, open-load as well as short-circuit to ground and battery can be detected.

Figure 20. Off-state diagnostic principle

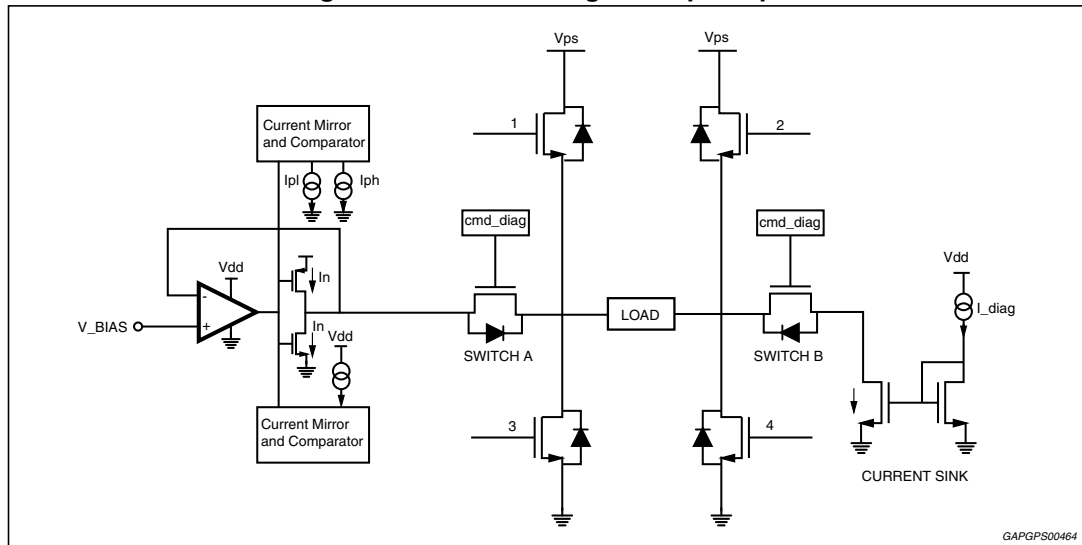

5.4 H-Bridge functional status

Three bits in the diagnosis register are used to give a feedback about the state of the H-Bridge. Status are Current Limitation (bit 4 "C_LIM"), Temperature Warning (bit 5 "T_WRN") and Bridge Enable Status (bit 7 "ACT"). Those bits do not report a failure but only a functional state of the H-bridge that could be useful to change the control strategy mainly in term of power dissipation.

6 Electrical specifications

6.1 Absolute maximum ratings

The component must withstand the overall following stimulus without any damage or latch-up. Beyond these values, damage to the component may occur.

Table 15. Absolute maximum ratings

| Symbol | Parameter | Test condition | Min. | Max. | Unit |
|----------------------------|----------------------|---|----------|----------------|------|
| V_{ps} | Supply voltage | Continuous Transient (0.5 s; $I \leq 10$ A) | -1 -2 | 40 40 | V |
| V_{dd} | Logic supply voltage | $0\text{ V} < V_{ps} < 40\text{ V}$ | -0.3 | 19 | V |
| V_{ddio} | SDO supply voltage | $0\text{ V} < V_{ps} < 40\text{ V}$ | -0.3 | 19 | V |
| V_i | Logic input voltage | $0\text{ V} < V_{ps} < 40\text{ V}$ $0\text{ V} < V_{dd} < 19\text{ V}$ | -0.3 | 19 | V |
| V_o | Logic output voltage | $0\text{ V} < V_{ps} < 40\text{ V}$ $0\text{ V} < V_{dd} < 18.7\text{V}$ | -0.3 | $V_{ddio}+0.3$ | V |
| Output pins (OUTx, VPS) | ESD Compliance | EIA/JESD22-A114-B | ± 4 | - | kV |
| Input pins | | | ± 2 | - | |
| - | ISO 7637 pulses | Cf. standards | - | - | - |
| - | Latch-up immunity | Jedec standard | -100 | +100 | mA |

Note: In case of load dump condition, status of device outputs is kept unchanged.

6.2 Thermal data

Table 16. Thermal data

| Symbol | Parameter | Test condition | Min. | Max. | Unit |
|----------------|--|-------------------------------------|------|------|------|
| T_j | Junction temperature | Failure condition | -40 | OTsd | °C |
| | | Lifetime | -40 | 150 | |
| T_{stg} | Storage temperature | - | -55 | 150 | °C |
| T_{amb} | Ambient temperature | $0\text{ V} < V_{ps} < 40\text{ V}$ | -40 | 125 | °C |
| $R_{thj-case}$ | Thermal resistance junction to case ⁽¹⁾ | Package PowerSO-20 | - | 1 | °C/W |
| | | Package PowerSO16 | - | 1 | |
| | | Package PowerSSO24 | - | 2 | |

1. Guaranteed by design and package characterization.

Figure 21. Thermal impedance (junction-ambient) of power packages

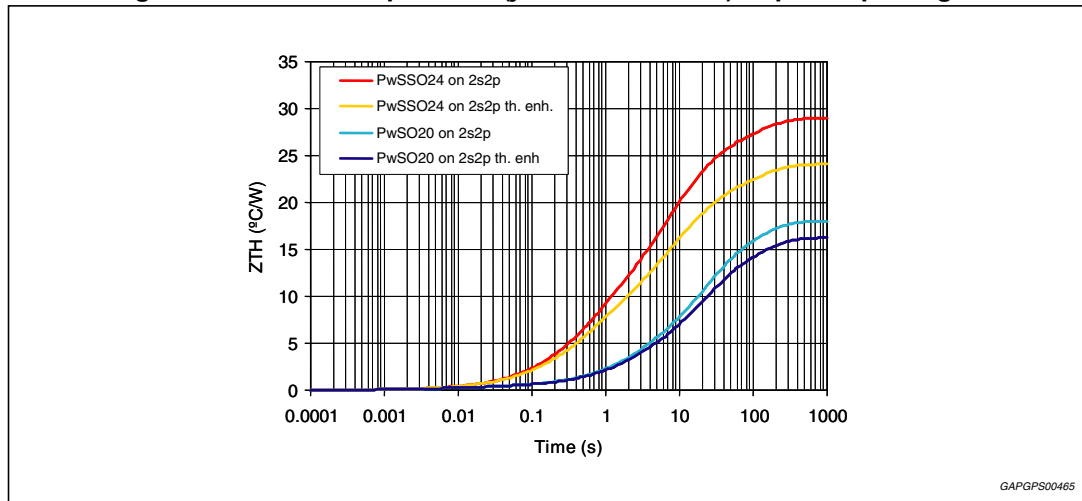

6.3 Range of functionality

Within the range of functionality, all L9958 functionalities have to be guaranteed. All voltages refers to GND. Currents are positive into and negative out of the specified pin.

Table 17. Range of functionality

| Pos. | Symbol | Parameter | Test condition | Min. | Typ. | Max. | Unit |
|------|--------------|--|--|-------------------|------|-------------------|------------|
| FR1 | V_{ps} | Supply voltage | - | $V_{ps_uv_off}$ | 14 | $28^{(1)}$ | V |
| FR2 | dV_{ps}/dt | Supply voltage slew rate | - | -20 | - | 20 | V/ μ s |
| FR3 | V_{dd} | Logic supply voltage | - | $V_{dd_uv_off}$ | 5 | $V_{dd_ov_off}$ | V |
| FR4 | dV_{dd}/dt | Logic supply voltage slew rate | - | - | - | $0.025^{(2)}$ | V/ μ s |
| FR5 | V_i | Logic input voltage (SDI, SCLK, NCS, DI, EN, DIR, PWM) | See also Table 15: Absolute maximum ratings. | -0.3 | - | $V_{dd_ov_off}$ | V |
| FR6 | V_{ddio} | SDO output voltage | - | 3 | - | 5.5 | V |
| FR7 | f_{spi} | SPI clock frequency | - | - | - | 5 | MHz |

1. In load dump conditions V_{ps} ranges between 28V and 40V. During load dump, status of device outputs is kept unchanged,
2. To VDD pin are connected 10 μ F and 10nF (close to the pin) capacitors.

6.4 Electrical characteristics

$T_{\text{case}} = -40\text{ °C}$ to 125 °C unless otherwise specified,

$V_{\text{dd}} = 4.5\text{ V}$ to 5.5 V unless otherwise specified

$V_{\text{ps}} = 4\text{ V}$ to 28 V unless otherwise specified

All voltages refer to GND. Currents are positive into and negative out of the specified pin.

6.4.1 Device supply

Table 18. Device supply

| Pos. | Symbol | Parameter | Test condition | Min. | Typ. | Max. | Unit |
|------|------------------|---------------------------|--|------|------|------|---------------|
| 1.1 | I_{ps} | Power supply current | $V_{\text{dd}} < 0.7\text{ V}$; $V_{\text{ps}} = 16\text{ V}$ from -40 °C to 25 °C | - | - | 20 | μA |
| | | | $V_{\text{dd}} < 0.7\text{ V}$; $V_{\text{ps}} = 16\text{ V}$ at 125 °C | - | - | 35 | μA |
| | | | $F_{\text{pwm}} = 0$, $I_{\text{out}} = 0$ | - | - | 20 | mA |
| 1.2 | I_{out} | Leakage current on output | Bridge in tri-state | - | - | 100 | μA |
| 1.3 | I_{cc} | Logic-supply current | $V_{\text{dd}} > V_{\text{dd_uv_on}}$ $F_{\text{PWM}} = 0$ | - | - | 5 | mA |
| | | | $F_{\text{PWM}} = 20\text{ kHz}$ (Average value) | - | - | 5 | mA |

6.4.2 Device supply monitoring

Table 19. Device supply monitoring

| Pos. | Symbol | Parameter | Test condition | Min. | Typ. | Max. | Unit |
|------|---------------------------|--|----------------------------|------|------|------|---------------|
| 2.1 | $V_{\text{ps_uv_off}}$ | V_{ps} under-voltage threshold | V_{ps} decreasing | - | - | 4 | V |
| 2.2 | $V_{\text{ps_uv_on}}$ | V_{ps} under-voltage threshold | V_{ps} increasing | - | - | 4.5 | V |
| 2.3 | $V_{\text{ps_uv_hyst}}$ | V_{ps} under-voltage hysteresis | - | 0.1 | - | - | V |
| 2.4 | $T_{\text{uv_vps}}$ | V_{ps} under-voltage filtering time | V_{ps} decreasing | 1 | - | 3 | μs |
| 2.5 | $V_{\text{dd_uv_off}}$ | V_{dd} under-voltage threshold | V_{dd} decreasing | 3 | - | 3.7 | V |
| 2.6 | $V_{\text{dd_uv_on}}$ | V_{dd} under-voltage threshold | V_{dd} increasing | 3.3 | - | 4 | V |
| 2.7 | $V_{\text{dd_uv_hyst}}$ | V_{dd} under-voltage hysteresis | - | 0.1 | - | - | V |
| 2.8 | $T_{\text{uv_Vdd}}$ | V_{dd} under-voltage filtering time | V_{dd} decreasing | 1 | - | 4 | μs |
| 2.9 | $V_{\text{dd_ov_off}}$ | V_{dd} over-voltage threshold | V_{dd} increasing | 5.8 | - | 6.8 | V |
| 2.10 | $V_{\text{dd_ov_on}}$ | V_{dd} over-voltage threshold | V_{dd} decreasing | 5.5 | - | 6.5 | V |
| 2.11 | $V_{\text{dd_ov_hyst}}$ | V_{dd} over-voltage hysteresis | - | 0.1 | - | - | V |
| 2.12 | $T_{\text{ov_Vdd}}$ | V_{dd} over-voltage filtering time | V_{dd} increasing | 60 | 100 | 140 | μs |

6.4.3 SPI

Table 20. SPI

| Pos. | Symbol | Parameter | Test condition | Min. | Typ. | Max. | Unit |
|------|------------------|--|--|------------------|------|------|---------------|
| 3.1 | f_{spi} | Clock frequency (50 % duty cycle) | - | - | - | 5 | MHz |
| 3.2 | T_{sdo_trans} | SDO transition speed, 20-80 % | $V_{sdo} = 5V, C_{load} = 50 \text{ pF}^{(1)}$ | 5 | - | 30 | ns |
| | | | $V_{sdo} = 5 \text{ V}, C_{load} = 150 \text{ pF}$ | 5 | - | 50 | ns |
| 3.3 | T_{clh} | Minimum time SCLK = HIGH | - | 75 | - | - | ns |
| 3.4 | T_{cll} | Minimum time SCLK = LOW | - | 75 | - | - | ns |
| 3.5 | T_{pold} | Propagation delay (SCLK to data at 10% of SDO rising edge) | - | - | - | 40 | ns |
| 3.6 | T_{csdv} | NCS = LOW to data at SDO active | - | - | - | 85 | ns |
| 3.7 | T_{sclch} | SCLK low before NCS low (setup time SCLK to NCS change H/L) | - | 75 | - | - | ns |
| 3.8 | T_{hclcl} | SCLK change L/H after NCS = low | - | 75 | - | - | ns |
| 3.9 | T_{sclsd} | SDI input setup time (SCLK change H/L after SDI data valid) | - | 40 | - | - | ns |
| 3.10 | T_{hclsd} | SDI input hold time (SDI data hold after SCLK change H/L) | - | 40 | - | - | ns |
| 3.11 | T_{sclcl} | SCLK low before NCS high | - | 100 | - | - | ns |
| 3.12 | T_{hclch} | SCLK high after NCS high | - | 100 | - | - | ns |
| 3.13 | T_{pchs} | NCS L/H to SDO @ high impedance | - | - | - | 75 | ns |
| 3.14 | T_{onncs} | NCS min. high time | - | 300 | - | - | ns |
| 3.15 | - | Capacitance at SDI, SCLK; NCS | - | - | - | 14 | pF |
| | - | Capacitance at SDO | - | - | - | 19 | pF |
| 3.16 | T_{fncs} | NCS Filter time will be ignored) Guaranteed by design (Pulses = T_{fncs}) | Guaranteed by design | 10 | - | 40 | ns |
| 3.17 | V_{ddio} | Supply voltage for SDO output buffer | - | 3 | - | 5.5 | V |
| 3.18 | I_{vddio} | Current consumption on Vddio | ⁽²⁾ | - | - | 1 | mA |
| 3.19 | sdo_H | High output level on SDO | $I_{sdo} = 1.5 \text{ mA}$ | $V_{ddio} - 0.4$ | - | - | V |
| 3.20 | sdo_L | Low output level on SDO | $I_{sdo} = 2 \text{ mA}$ | - | - | 0.4 | V |
| 3.21 | I_{sdo} | Tri state leakage current | NCS = HIGH $V_{DDIO} = 5 \text{ V}$ | -5 | - | 5 | μA |

1. Not tested – guaranteed by $C_{load} = 150 \text{ pF}$ measurement

2. Measured for PSO16 at wafer sort level only.

6.4.4 Digital inputs: TTL // 3.3V / 5V CMOS compatible

Table 21. Digital inputs: TTL // 3.3V / 5V CMOS compatible

| Pos. | Symbol | Parameter | Test condition | Min. | Typ. | Max. | Unit |
|------|---------------|---|--|------|------|--------------|---------------|
| 4.1 | V_{ih} | Input voltage HIGH | - | 2 | - | $V_{dd}+0.3$ | V |
| 4.2 | V_{il} | Input voltage LOW | - | -0.3 | - | 0.8 | V |
| 4.3 | | Hysteresis of input voltage | - | 200 | - | - | mV |
| 4.4 | I_{inl} | Input current source for: DI / NCS / SCLK / SDI | $V_{in} = 0\text{ V}$ | -100 | - | -30 | μA |
| | | | $V_{in} = 5\text{ V}$ No back supply allowed | - | - | 5 | |
| 4.5 | I_{inh} | Input current sink for: EN / DIR / PWM | $V_{in} = 5\text{ V}$ | 30 | - | 100 | μA |
| | | | $V_{in} = 0\text{ V}$ | -5 | - | - | |
| 4.6 | $V_{r_{ext}}$ | External resistor | - | - | 1.24 | - | V |
| | R_{ext} | | - | - | 10 | - | k Ω |
| | | | Overall tolerance can be taken as 3.5 % | - | 1 | - | % |

6.4.5 Bridge output drivers

Table 22. Bridge output drivers

| Pos. | Symbol | Parameter | Test condition | Min. | Typ. | Max. | Unit |
|------|---------------|--|--|------|------|------|------------|
| 5.1 | R_{dson_h} | High-side transistor R_{dson} | $T_j = 150\text{ }^\circ\text{C}$, $I_{out} = 3\text{ A}$ $4\text{ V} < V_{ps} < 5\text{ V}$ | - | - | 300 | m Ω |
| | | | $T_j = 150\text{ }^\circ\text{C}$, $I_{out} = 3\text{ A}$ $V_{ps} > 5\text{ V}$ | - | - | 150 | |
| 5.2 | R_{dson_l} | Low-side transistor R_{dson} | $T_j = 150\text{ }^\circ\text{C}$, $I_{out} = 3\text{ A}$ $4\text{ V} < V_{ps} < 5\text{ V}$ | - | - | 300 | m Ω |
| | | | $T_j = 150\text{ }^\circ\text{C}$, $I_{out} = 3\text{ A}$ $V_{ps} > 5\text{ V}$ | - | - | 150 | |
| 5.3 | V_{bd_h} | Body diode forward voltage drop high-side transistor | $I_{diode} = 3\text{ A}$ | - | 1.2 | 2 | V |
| 5.4 | V_{bd_l} | Body diode forward voltage drop low-side transistor | $I_{diode} = 3\text{ A}$ | - | 1.2 | 2 | V |

6.4.6 Over-temperature monitoring

Table 23. Over-temperature monitoring

| Pos. | Symbol | Parameter | Test condition | Min. | Typ. | Max. | Unit |
|------|------------------|---------------------------------|---------------------------------|------|------|------|------|
| 6.1 | OTwarn | Over-temperature warning | - | 150 | - | 170 | °C |
| 6.2 | OTsd | Over-temperature shut-down | - | 170 | - | 200 | °C |
| 6.3 | OThyst | Over-temperature hysteresis | - | 10 | - | - | °C |
| 6.4 | T _{TSD} | Over-temperature filtering time | Guaranteed by clock measurement | - | 36 | - | µs |

6.4.7 Current limitation and over-current detection

Table 24. Current limitation and over-current detection

| Pos. | Symbol | Parameter | Test condition | Min. | Typ. | Max. | Unit |
|------|---------------------|--|--|---|---|---|------|
| 7.1 | I _{lim_H} | Current limitation high threshold | CL1:0 = 00; -40 °C ≤ T _j ≤ 150 °C | 2 | 2.5 | 3.1 | A |
| | | | CL1:0 = 01; -40 °C ≤ T _j ≤ 150 °C | 3.5 | 4 | 4.85 | |
| | | | CL1:0 = 10; -40 °C ≤ T _j < 25 °C | 5.5 | 6.75 | 8 | |
| | | | CL1:0 = 10; 25 °C ≤ T _j ≤ 150 °C | 5.5 | 6.6 | 7.7 | |
| | | | CL1:0 = 11; -40 °C ≤ T _j < 25 °C | 7.8 | 9.1 | 10.4 | |
| | | | CL1:0 = 11; 25 °C ≤ T _j ≤ 150 °C | 7.6 | 8.6 | 9.6 | |
| | | | CL1:0 = XX, T _j = OTsd | 2 | 2.5 | 3 | |
| 7.2 | I _{lim_L} | Current limitation low threshold | CL1:0 = 0X; -40 °C ≤ T _j ≤ 150 °C | I _{lim_H} -0.2 | I _{lim_H} ⁻ 0.5 | I _{lim_H} ⁻ 0.8 | A |
| | | | CL1:0 = 10; -40 °C ≤ T _j < 25 °C | I _{lim_H} ⁻ 0.35 | I _{lim_H} ⁻ 0.65 | I _{lim_H} ⁻ 0.95 | |
| | | | CL1:0 = 10; 25 °C ≤ T _j ≤ 150 °C | I _{lim_H} ⁻ 0.35 | I _{lim_H} ⁻ 0.55 | I _{lim_H} ⁻ 0.85 | |
| | | | CL1:0 = 11; -40 °C ≤ T _j < 25 °C | I _{lim_H} -0.4 | I _{lim_H} ⁻ 0.7 | I _{lim_H} -1 | |
| | | | CL1:0 = 11; 25 °C ≤ T _j ≤ 150 °C | I _{lim_H} -0.4 | I _{lim_H} ⁻ 0.55 | I _{lim_H} ⁻ 0.95 | |
| 7.3 | T _{limh} | High current limitation threshold filtering time | can be included in T _{blank} | 0.1 | - | 1 | µs |
| 7.4 | T _{liml} | Low current limitation threshold filtering time | - | 1 | - | 3 | µs |
| 7.5 | T _{offmin} | Current limitation delay time | - | 30 | - | 45 | µs |
| 7.6 | T _b | Blanking time | - | 4.9 | - | 8.7 | µs |

Table 24. Current limitation and over-current detection (continued)

| Pos. | Symbol | Parameter | Test condition | Min. | Typ. | Max. | Unit |
|------|------------------|--|--|------------------|------|------|---------------|
| 7.7 | loc_ls loc-hs | Low-side over-current threshold | CL1:0 = 0X; $-40\text{ °C} \leq T_j \leq 150\text{ °C}$ | 5.5 | 7.7 | 11 | A |
| | | | CL1:0 = 1X; $-40\text{ °C} \leq T_j < 25\text{ °C}$ | 9.3 | 12 | 16.5 | |
| | | | CL1:0 = 1X; $25\text{ °C} \leq T_j \leq 150\text{ °C}$ | 9.3 | 11.5 | 14 | |
| | Tracking | High-side over-current threshold | CL1:0 = 0X; CL1:0 = 10; $-40\text{ °C} \leq T_j \leq 150\text{ °C}$ | $I_{lim_h}+2$ | - | - | |
| | | | CL1:0 = 11; $-40\text{ °C} \leq T_j \leq 150\text{ °C}$ | $I_{lim_h}+1.3$ | - | - | |
| 7.8 | Toc_ls Toc_hs | Low-side & high-side over-current detection filtering time | - | 0.8 | - | 2.5 | μs |

6.4.8 Diagnostic of open-load in on-state

Table 25. Diagnostic of open-load in on-state

| Pos. | Symbol | Parameter | Test condition | Min. | Typ. | Max. | Unit |
|------|----------|--------------------------------|--|------|------|------|---------------|
| 8.1 | Is_OL-on | Current source | $T_j = -40\text{ °C}$ (go-no-go functional test) | 50 | - | 120 | μA |
| | | | $T_j = 25\text{ °C}$ to 150 °C (go-no-go functional test) | 50 | - | 100 | |
| 8.2 | Tmeas_on | Detection time (settling time) | - | - | 3 | 5 | μs |

6.4.9 Off-state diagnostic

Table 26. Off-state diagnostic

| Pos. | Symbol | Parameter | Test condition | Min. | Typ. | Max. | Unit |
|------|-------------------------|---|--|------|------|------|---------------|
| 9.1 | R _{OL} | Load detection threshold | | 10 | 60 | 200 | k Ω |
| 9.2 | Tdiag_off | Delay time before enabling off-state diagnostic structure | diag after on-state Guaranteed through SCAN | 100 | 125 | 150 | ms |
| 9.3 | T _{diag-off_1} | Off-state diag filtering time when OUT 1 and/or 2 decrease from V _{ps} | used each time OUT pins are released from V _{ps} (after release of SCB, after Tdiag_off) Guaranteed through SCAN | 2.4 | 3 | 3.6 | ms |
| 9.4 | T _{diag-off_2} | Off-state diagnostic filtering time on failure detection | One symmetric filter for each failure type (OL, SCG, SCB) Guaranteed through SCAN | 200 | 250 | 300 | μs |
| 9.5 | T _{clock} | Oscillator frequency | - | 4 | - | 6 | MHz |

6.4.10 Timing characteristics

Table 27. Timing characteristics

| Pos. | Symbol | Parameter | Test condition | Min. | Typ. | Max. | Unit |
|-------|-----------------|--|--|------|------|------|------------|
| 10.1 | f_{pwm} | PWM frequency | - | - | - | 20 | kHz |
| 10.2 | T_{don} | Delay time for switch-on | $R_{load} @ I_{out} = 3 A$ PWM \rightarrow 90% V_{out} (or 10% I_{out}) | - | - | 10 | μs |
| | T_{doff} | Delay time for switch-off | $R_{load} @ I_{out} = 3 A$ PWM \rightarrow 10% V_{out} (or 90% I_{out}) | - | - | 10 | μs |
| | ΔT_d | Delay time: symmetry | PWM accuracy = 1% @ 2kHz | - | - | 5 | μs |
| 10.3 | T_{d_dis} | Disable delay time | DI / EN \rightarrow 90% OUTx @ $I_{out} = 3 A$ | - | - | 6 | μs |
| 10.4 | T_{d_en} | Enable delay time | DI / EN \rightarrow 10% OUT | - | - | 6 | μs |
| 10.5 | T_{d_pow} | Power-on delay time | DIR= PWM=EN=1 / DI=0 no load / $V_{PS} =$ V_{dd} increasing $V_{ps} = V_{dd} \rightarrow$ 10% V_{out1} (= V_{ps}) | - | - | 200 | μs |
| 10.6 | T_{d_filter} | DI / EN digital filter time | - | 1 | - | 3 | μs |
| 10.7 | T_{rise_H} | Low-side transistor rise time | Non selectable by SPI | 0.04 | - | 0.2 | μs |
| 10.8 | T_{fall_H} | Low-side transistor fall time | Non selectable by SPI | 1 | - | 3 | μs |
| 10.9 | dV_{out}/dt | Voltage slew rate for high-side transistors (Measurement is performed between 30% and 70% of the slope) | super fast mode | 7 | 14 | 24 | V/ μs |
| | | | VSR = 0 | 2 | 4 | 6 | |
| | | | VSR = 1 | 1 | 2 | 3 | |
| 10.10 | dI_{out}/dt | Current slew rate for high-side transistors (Measurement is performed between 40% and 60% of the slope) | ISR=0 | 1.5 | 3 | 4.5 | A/ μs |
| | | | ISR=1 | 0.15 | 0.3 | 0.45 | |
| 10.11 | T_{diag} | Timing for reliable diagnostic | Guaranteed through SCAN pattern | 35 | - | 55 | μs |

7 Application circuit

Figure 22. Application circuit

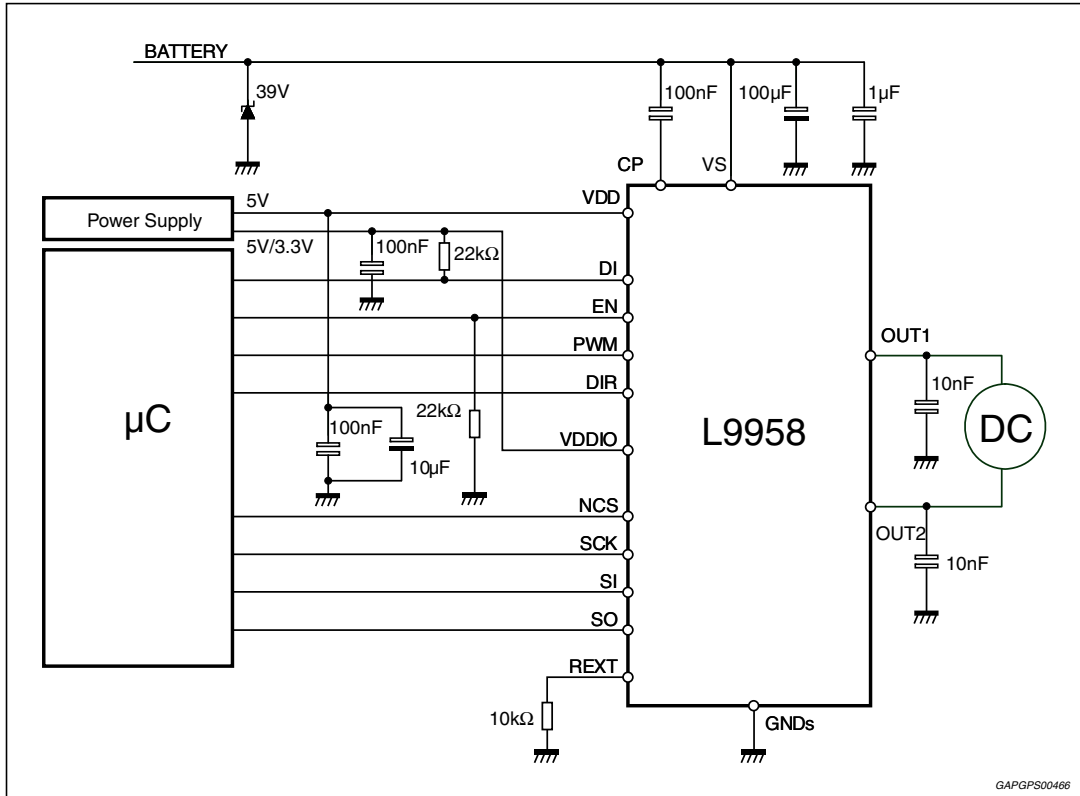

1. The above application diagram shows all the suggested components for a proper device operation.

8 Package information

In order to meet environmental requirements, ST offers these devices in different grades of ECOPACK® packages, depending on their level of environmental compliance. ECOPACK® specifications, grade definitions and product status are available at: www.st.com.

ECOPACK® is an ST trademark.

Figure 23. PowerSO-20 mechanical data and package dimensions

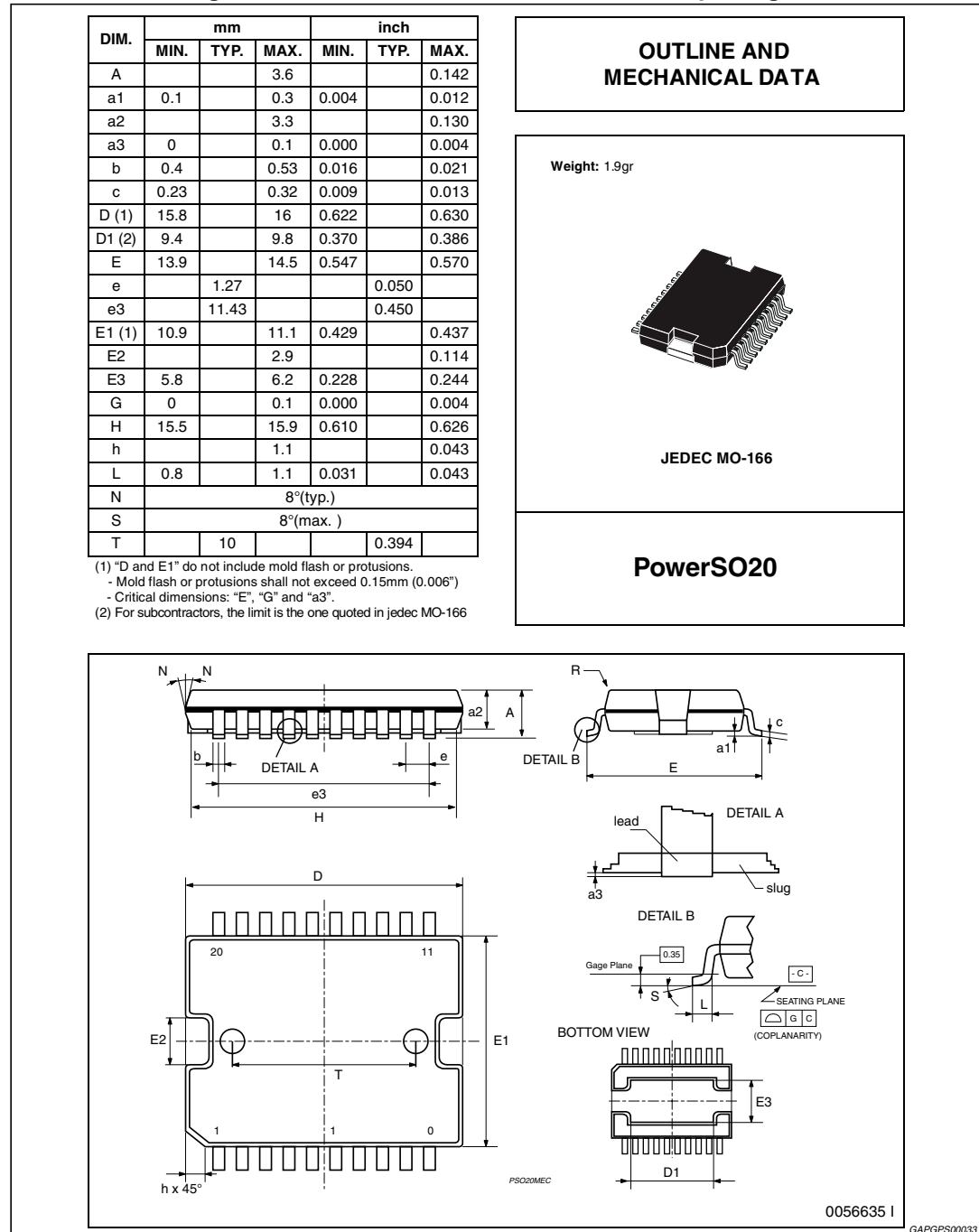
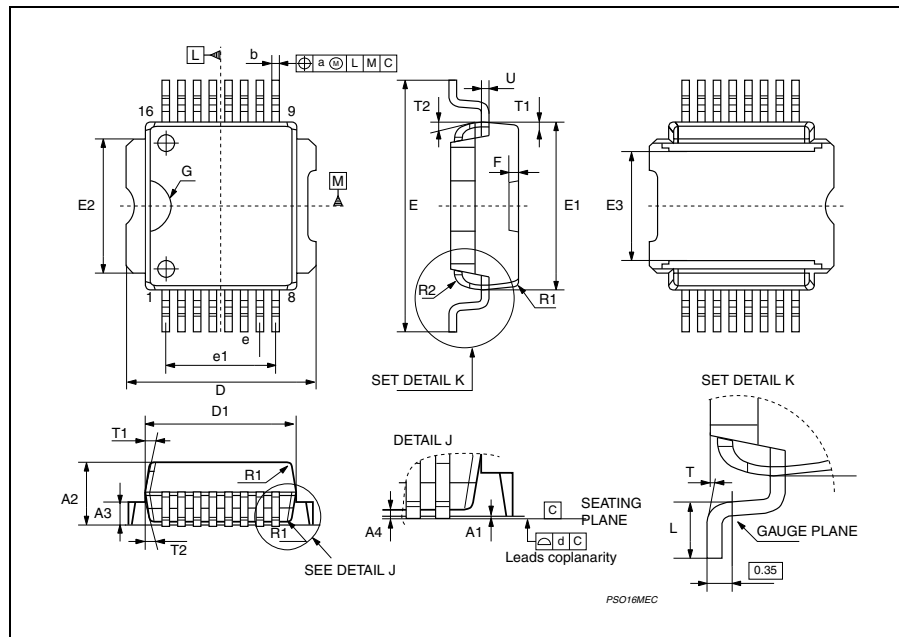
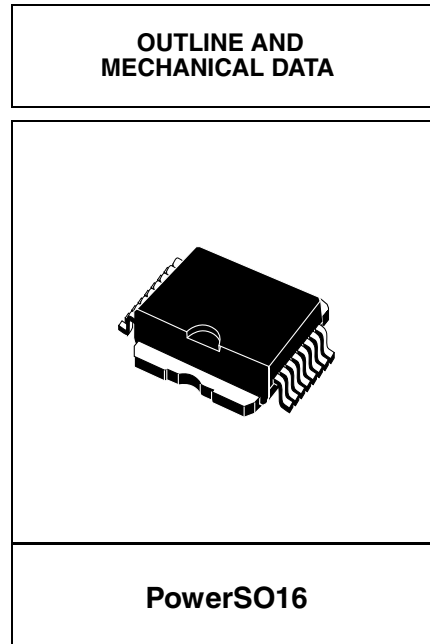

Figure 24. PowerSO16 mechanical data and package dimensions

| DIM. | mm | | | inch | | |
|-------|---------------------------------|------|-------|-------|-------|-------|
| | MIN. | TYP. | MAX. | MIN. | TYP. | MAX. |
| A1 | 0 | 0.05 | 0.1 | 0 | 0.002 | 0.004 |
| A2 | 3.4 | 3.5 | 3.6 | 0.133 | 0.137 | 0.141 |
| A3 | 1.2 | 1.3 | 1.4 | 0.048 | 0.05 | 0.052 |
| A4 | 0.15 | 0.2 | 0.25 | 0.006 | 0.007 | 0.01 |
| a | | 0.2 | | | 0.007 | |
| b | 0.27 | 0.35 | 0.43 | 0.011 | 0.013 | 0.017 |
| c | 0.23 | 0.27 | 0.32 | 0.009 | 0.01 | 0.012 |
| D | 9.4 | 9.5 | 9.6 | 0.37 | 0.374 | 0.377 |
| D1 | 7.4 | 7.5 | 7.6 | 0.291 | 0.295 | 0.299 |
| d | | 0.1 | | | 0.004 | |
| E (1) | 13.85 | 14.1 | 14.35 | 0.545 | 0.555 | 0.565 |
| E1 | 9.3 | 9.4 | 9.5 | 0.366 | 0.37 | 0.374 |
| E2 | 7.3 | 7.4 | 7.5 | 0.287 | 0.291 | 0.295 |
| E3 | 5.9 | 6.1 | 6.3 | 0.232 | 0.24 | 0.248 |
| e | | 0.8 | | | 0.031 | |
| e1 | | 5.6 | | | 0.22 | |
| F | | 0.5 | | | 0.019 | |
| G | | 1.2 | | | 0.047 | |
| L | 0.8 | 0.95 | 1.1 | 0.031 | 0.037 | 0.043 |
| R1 | | | 0.25 | | | 0.01 |
| R2 | | 0.8 | | | 0.031 | |
| T | 2° (min.), 5° (typ.), 8° (max.) | | | | | |
| T1 | 6° (typ.) | | | | | |
| T2 | 10° (typ.) | | | | | |

(1) Resin protrusions not included (max value: 0.1mm per side).



GAPGPS00467

Figure 25. PowerSSO24 mechanical data and package dimensions

| Dim. | mm | | | inch | | |
|------------------|----------------------|------|---------------------|----------------------|-------|----------------------|
| | Min. | Typ. | Max. | Min. | Typ. | Max. |
| A | | | 2.45 | | | 0.0965 |
| A2 | 2.15 | | 2.35 | 0.084 | | 0.0925 |
| a1 | 0 | | 0.10 | 0 | | 0.003 |
| b | 0.33 | | 0.51 | 0.013 | | 0.020 |
| c | 0.23 | | 0.32 | 0.009 | | 0.012 |
| D ⁽¹⁾ | 10.10 | | 10.50 | 0.398 | | 0.413 |
| E ⁽¹⁾ | 7.40 | | 7.60 | 0.291 | | 0.299 |
| e0 | | .80 | | | 0.031 | |
| e3 | | 8.80 | | | 0.346 | |
| F2 | | .30 | | | 0.090 | |
| G | | | 0.10 | | | 0.004 |
| G1 | | | 0.06 | | | 0.002 |
| H | 10.10 | | 10.50 | 0.398 | | 0.413 |
| h | | | 0.40 | | | 0.016 |
| k | 0° (min.), 8° (max.) | | | | | |
| L | 0.55 | | 0.85 | 0.0217 | | 0.0335 |
| O | | 1.20 | | | | 0.047 |
| Q | | 0.80 | | | | 0.031 |
| S | | 2.90 | | | | 0.114 |
| T | | 3.65 | | | | 0.143 |
| U | | 1.0 | | | | 0.039 |
| N | 10° (max) | | | | | |
| X | 4.10 | | 4.70 | 0.161 | | 0.185 |
| Y | 6.50 | | 7.10 | 0.256 | | 0.279 |
| | 4.90 ⁽⁴⁾ | | 5.50 ⁽⁴⁾ | 0.192 ⁽⁴⁾ | | 0.216 ⁽⁴⁾ |

- (1) "D and E1" do not include mold flash or protrusions.
Mold flash or protrusions shall not exceed 0.15mm (0.006")
- (2) No intrusion allowed inwards the leads.
- (3) Flash or bleeds on exposed die pad shall not exceed 0.4 mm per side
- (4) Variation for small window leadframe option.

OUTLINE AND MECHANICAL DATA

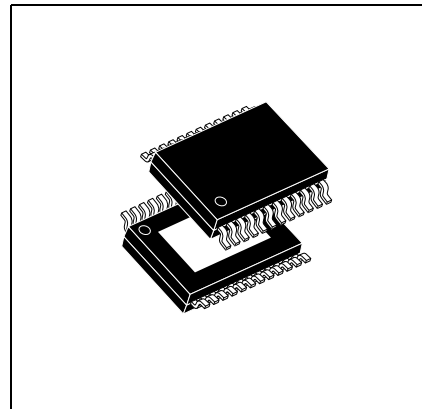

PowerSSO24 (Exposed pad down)

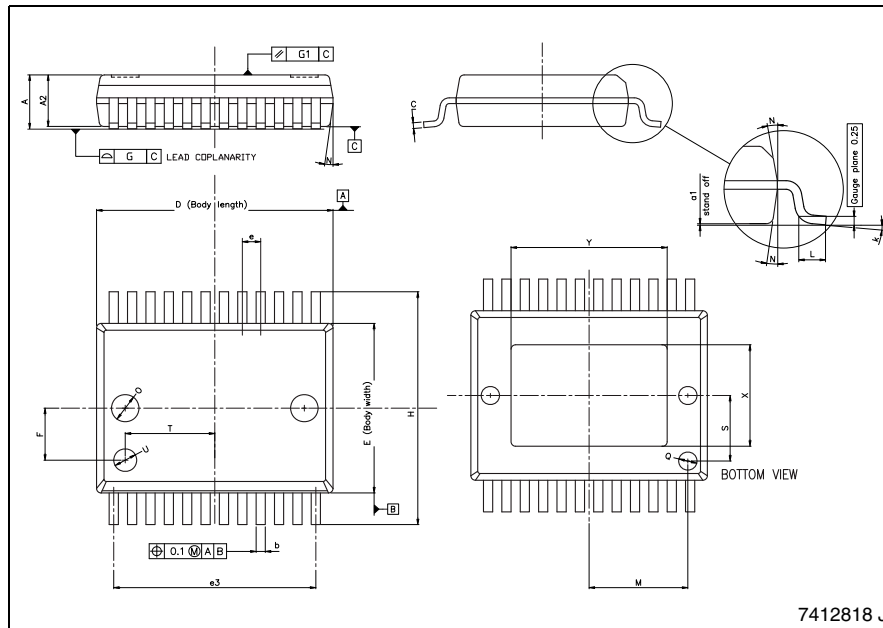

7412818 J

GAGP500468

9 Revision history

Table 28. Document revision history

| Date | Revision | Changes |
|-------------|----------|--|
| 16-Mar-2010 | 1 | Initial release. |
| 08-Apr-2011 | 2 | Updated <i>Table 27: Timing characteristics on page 32</i> (Pos. 10.8). |
| 03-Aug-2011 | 3 | Updated <i>Table 17, Table 20, Table 24</i> and <i>Table 27</i> . |
| 23-Mar-2012 | 4 | Updated: <i>Table 17: Range of functionality;</i> <i>Table 20: SPI.</i> |
| 19-Sep-2013 | 5 | Updated disclaimer. |
| 05-Dec-2013 | 6 | Updated <i>Table 24: Current limitation and over-current detection</i> pag 31. |

Please Read Carefully:

Information in this document is provided solely in connection with ST products. STMicroelectronics NV and its subsidiaries ("ST") reserve the right to make changes, corrections, modifications or improvements, to this document, and the products and services described herein at any time, without notice.

All ST products are sold pursuant to ST's terms and conditions of sale.

Purchasers are solely responsible for the choice, selection and use of the ST products and services described herein, and ST assumes no liability whatsoever relating to the choice, selection or use of the ST products and services described herein.

No license, express or implied, by estoppel or otherwise, to any intellectual property rights is granted under this document. If any part of this document refers to any third party products or services it shall not be deemed a license grant by ST for the use of such third party products or services, or any intellectual property contained therein or considered as a warranty covering the use in any manner whatsoever of such third party products or services or any intellectual property contained therein.

UNLESS OTHERWISE SET FORTH IN ST'S TERMS AND CONDITIONS OF SALE ST DISCLAIMS ANY EXPRESS OR IMPLIED WARRANTY WITH RESPECT TO THE USE AND/OR SALE OF ST PRODUCTS INCLUDING WITHOUT LIMITATION IMPLIED WARRANTIES OF MERCHANTABILITY, FITNESS FOR A PARTICULAR PURPOSE (AND THEIR EQUIVALENTS UNDER THE LAWS OF ANY JURISDICTION), OR INFRINGEMENT OF ANY PATENT, COPYRIGHT OR OTHER INTELLECTUAL PROPERTY RIGHT.

ST PRODUCTS ARE NOT DESIGNED OR AUTHORIZED FOR USE IN: (A) SAFETY CRITICAL APPLICATIONS SUCH AS LIFE SUPPORTING, ACTIVE IMPLANTED DEVICES OR SYSTEMS WITH PRODUCT FUNCTIONAL SAFETY REQUIREMENTS; (B) AERONAUTIC APPLICATIONS; (C) AUTOMOTIVE APPLICATIONS OR ENVIRONMENTS, AND/OR (D) AEROSPACE APPLICATIONS OR ENVIRONMENTS. WHERE ST PRODUCTS ARE NOT DESIGNED FOR SUCH USE, THE PURCHASER SHALL USE PRODUCTS AT PURCHASER'S SOLE RISK, EVEN IF ST HAS BEEN INFORMED IN WRITING OF SUCH USAGE, UNLESS A PRODUCT IS EXPRESSLY DESIGNATED BY ST AS BEING INTENDED FOR "AUTOMOTIVE, AUTOMOTIVE SAFETY OR MEDICAL" INDUSTRY DOMAINS ACCORDING TO ST PRODUCT DESIGN SPECIFICATIONS. PRODUCTS FORMALLY ESCC, QML OR JAN QUALIFIED ARE DEEMED SUITABLE FOR USE IN AEROSPACE BY THE CORRESPONDING GOVERNMENTAL AGENCY.

Resale of ST products with provisions different from the statements and/or technical features set forth in this document shall immediately void any warranty granted by ST for the ST product or service described herein and shall not create or extend in any manner whatsoever, any liability of ST.

ST and the ST logo are trademarks or registered trademarks of ST in various countries.

Information in this document supersedes and replaces all information previously supplied.

The ST logo is a registered trademark of STMicroelectronics. All other names are the property of their respective owners.

© 2013 STMicroelectronics - All rights reserved



STMicroelectronics group of companies

Australia - Belgium - Brazil - Canada - China - Czech Republic - Finland - France - Germany - Hong Kong - India - Israel - Italy - Japan - Malaysia - Malta - Morocco - Philippines - Singapore - Spain - Sweden - Switzerland - United Kingdom - United States of America

www.st.com

Looking for pricing, stock, or lifecycle information?

Click below to explore more details on WIN SOURCE:

-  [View L9958SBTR on WIN SOURCE](#)
-  [STMicroelectronics](#) Information

Optimize Your Supply Chain with WIN SOURCE Solutions

-  Global Sourcing Solution
-  Obsolete Management
-  Cost Control Management
-  Shortage Management
-  Alternative Solution
-  Excess Inventory Management