

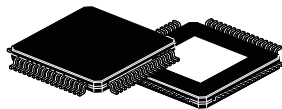

THE DATASHEET OF L9177ATR



Automotive engine management control IC for small engines



TQFP64 exposed pad down

GADG160K171506PS

Features

- AEC-Q100 qualified 
- Supply voltage from 6 V to 18 V
 - Basic functionality guaranteed down to 3.9 V
- 5 V regulator up to 300 mA with thermal shutdown protection in current limitation condition
- 5 V tracking regulator up to 40 mA and short to battery protection
- 5 V standby regulator up to 2.5 mA
- 2 channels injectors drivers
 - Parallel and serial driving
 - Output internally clamped to 60 V
 - Minimum overcurrent at 2.8 A
 - Ron 0.6 Ω worst case (at T_j = 150 °C)
- 3 relay drivers
 - 2 with parallel and serial driving, 1 with serial driving
 - Output internally clamped to 45 V
 - Minimum guaranteed output current 1 A
 - Ron 1.5 Ω worst case (at T_j = 150 °C)
- Tachometer driver
 - Parallel and serial driving
 - Minimum guaranteed output current 25 mA
 - Ron 5 Ω worst case (at T_j = 150 °C)
- Current limited low side driver (LSD)
 - Serial driving
 - Output internally clamped to 45 V
 - Minimum guaranteed output current 1 A (2 A during in-rush)
 - Ron 1.5 Ω worst case (at T_j = 150 °C)
- Stepper motor driver
 - Parallel driving
 - Minimum guaranteed output current 500 mA - full step
 - Ron 2.6 Ω worst case on the diagonal (at T_j = 150 °C)
- O2 sensor heater
 - Parallel and serial driving
 - Output internally clamped to 45 V
 - Minimum guaranteed output current 3 A
 - Ron 0.5 Ω worst case (at T_j = 150 °C)
- Protected high side driver
 - 100 mA min. current limitation threshold
- Full diagnosis by SPI
 - Injector driver: OL, STG, OC
 - Relay and current limited LSD drivers: OL, STG, OC

Product status link

L9177A

Product summary

Order code	Package	Packing
L9177A	TQFP64 (10x10 mm), exposed pad down	Tray
L9177ATR	(7.5x7.5 mm)	Tape and reel

- O2 sensor heater: OL, STG, OC
- Tachometer: OL, STG, OC
- Stepper motor driver: OL, STG, STB, OC
- general diagnostic: over-temperature
- Protection for STB, STG (for stepper motor drivers and tracking regulator)
- Self configuring variable reluctance sensor interface
- K-line transceiver
- Microcontroller reset logic
- Small Factor form package TQFP64 10 x 10 mm exposed pad down

Description

L9177A is a device realized in ST BCD proprietary technology, able to provide the full set of power supplies and signal preprocessing peripherals needed to control a 2 Cylinder internal combustion Engine for Low End Application (e.g. small motorcycle, K-car, nautical engines, etc.).

L9177A integrates a 5 V 300 mA main voltage regulator, a 5 V 40 mA tracking regulator for sensor supply and a 2.5 mA 5 V standby regulator.

The two channels injector drivers, the O2 sensor heater and two relay drivers can be controlled both with parallel input and with SPI interface. One additional relay driver and the current limited low side driver are controlled by SPI. The stepper motor driver is designed for a double winding coil motor, used for engine idle speed control.

Low side drivers implement SR control to minimize emission.

A protected 50 mA high side driver is provided.

A Variable Reluctance Sensor interface allows the connection to a commercial magnetic pick-up, allowing the indirect measurement of internal combustion engine crank angle. A K-line (standard ISO-9141 compatible) is provided as data communication interface.

All functionalities are fully protected and provide complete diagnostics via a 24-bit SPI interface. An overall protection against over temperature is provided as well.

The device is available in TQFP64 10x10 mm package with exposed pad for power dissipation optimization.

1 Block diagram and pin description

1.1 Block diagram

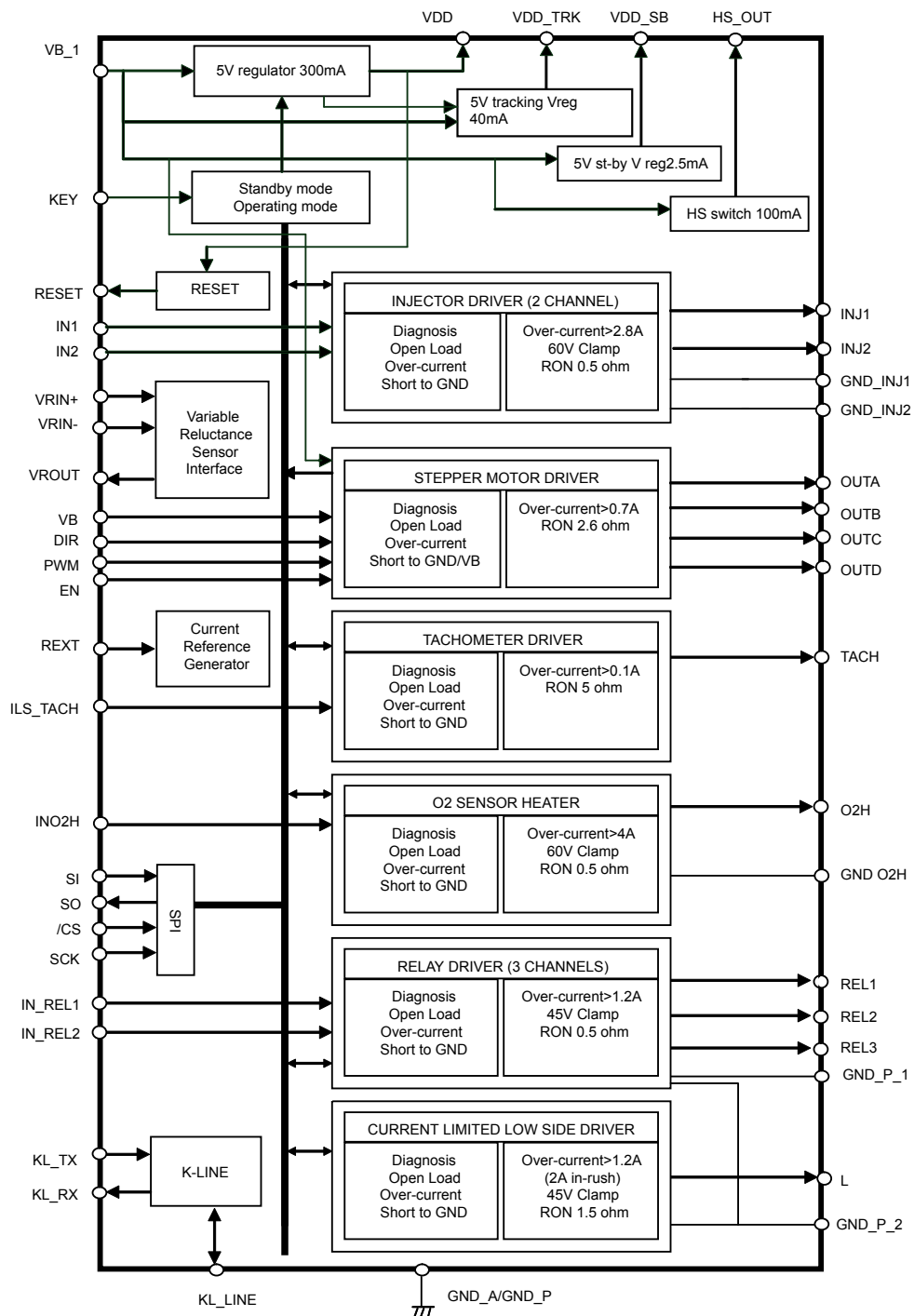
Figure 1. Block diagram

GAGGPS00585

1.2 Pin description

Figure 2. Pin connection (top view)

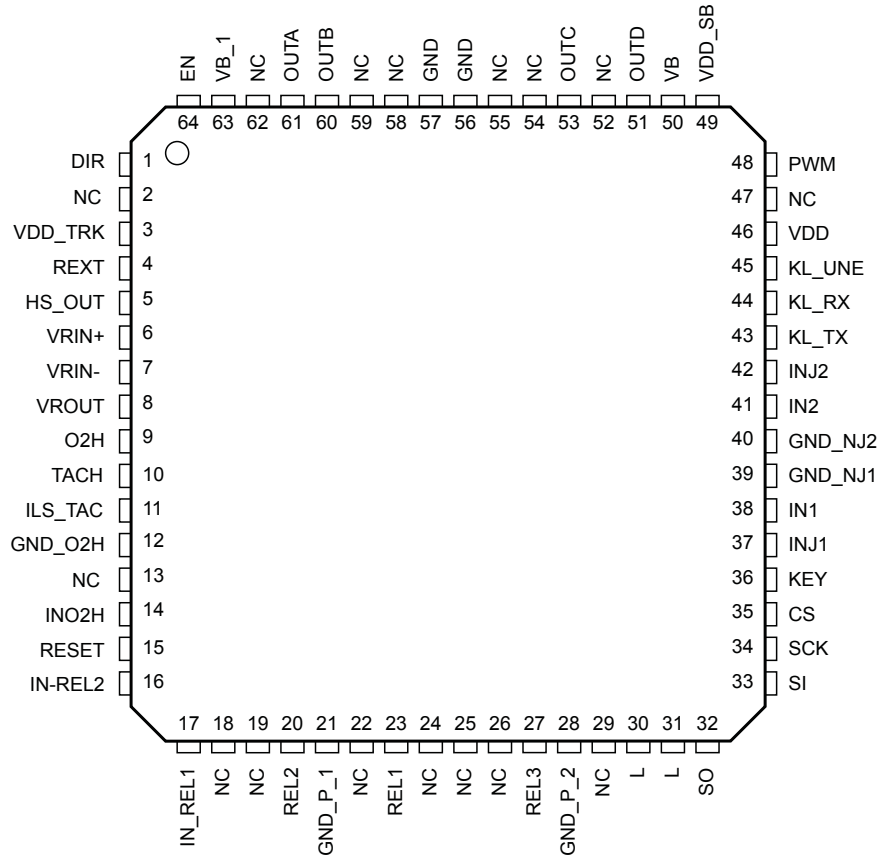

GAPG0403151617PS

Table 1. Pin function

Pin #	Pin name	Description	I/O type	Class
1	DIR	Logic input to set stepper motor direction	I	SIGNAL
2	NC	Not connected	-	-
3	VDD_TRK	Tracking voltage regulator output	O	PWR
4	REXT	External resistor for precision current reference	I	SIGNAL
5	HS_OUT	High side switch output	O	PWR
6	VRIN+	VRS positive differential input	I	SIGNAL
7	VRIN-	VRS negative differential input	I	SIGNAL
8	VROUT	VRS output	O	SIGNAL
9	O2H	O2 sensor heater output	O	PWR
10	TACH	Tachometer driver output	O	PWR
11	ILS_TACH	Tachometer driver input	I	SIGNAL
12	GND_O2H	O2 sensor heater ground	GND	PWR
13	NC	Not connected	-	-
14	INO2H	O2 sensor heater input	I	SIGNAL

Pin #	Pin name	Description	I/O type	Class
15	RESET	Reset signal to the micro	O	SIGNAL
16	IN_REL2	Relay 2 parallel control input	I	SIGNAL
17	IN_REL1	Relay 1 parallel control input	I	SIGNAL
18	NC	Not connected	-	-
19	NC	Not connected	-	-
20	REL2	Relay 2 driver output	O	PWR
21	GND_P_1	Power ground relay 1-2	O	PWR
22	NC	Not connected	-	-
23	REL1	Relay 1 driver output	O	PWR
24	NC	Not connected	-	-
25	NC	Not connected	-	-
26	NC	Not connected	-	-
27	REL3	Relay 3 driver output	O	PWR
28	GND_P_2	Power ground for current limited LSD	GND	PWR
29	NC	Not connected	-	-
30	L	Current limited LSD driver output	O	PWR
31	L	Current limited LSD driver output	O	PWR
32	SO	SPI data out	O	SIGNAL
33	SI	SPI data in	I	SIGNAL
34	SCK	SPI serial clock	I	SIGNAL
35	CS	SPI chip select	I	SIGNAL
36	KEY	Key signal	I	SIGNAL
37	INJ1	Injector 1 driver power output	O	PWR
38	IN1	Injector 1 driver input command	I	SIGNAL
39	GND_INJ1	Injector 1 ground	GND	PWR
40	GND_INJ2	Injector 2 ground	GND	PWR
41	IN2	Injector 2 driver input command	I	SIGNAL
42	INJ2	Injector 2 driver power output	O	PWR
43	KL_TX	K-Line TX digital IN	I	SIGNAL
44	KL_RX	K-Line RX digital OUT	O	SIGNAL
45	KL_LINE	K-Line	I/O	PWR
46	VDD	5 V voltage regulator output	O	PWR
47	NC	Not connected	-	-
48	PWM	Logic Input to set Stepper Motor Speed	I	SIGNAL
49	VDD_SB	5 V standby voltage regulator output	O	PWR
50	VB	Battery line to bridge 2	I	PWR
51	OUTD	Output bridge 2	O	PWR
52	NC	Not connected	-	-
53	OUTC	Output bridge 2	O	PWR
54	NC	Not connected	-	-

Pin #	Pin name	Description	I/O type	Class
55	NC	Not connected	-	-
56	GND	Analog and power ground	GND	PWR
57	GND	Analog and power ground	GND	PWR
58	NC	Not connected	-	-
59	NC	Not connected	-	-
60	OUTB	Output bridge 1	O	PWR
61	OUTA	Output bridge 1	O	PWR
62	NC	Not connected	-	-
63	VB_1	Battery line to bridge1	I	PWR
64	EN	Logic input to enable stepper motor	I	SIGNAL
-	Pad	Exposed pad	GND	PWR

2 Electrical specifications

2.1 Operating range

The device may not operate properly if maximum operating conditions are exceeded.

Table 2. Operating conditions

Parameter	Value	Unit
VB, VB_1 supply voltage	6 to 18 ⁽¹⁾	V
I/O logic	0 to VDD	V
Stepper motor outputs	-0.3 to VB, VB_1	V
Low side outputs	-0.3 to clamp voltage	V

1. See [Section 2.1.1](#).

2.1.1 Supply voltage

- Below 3.9 V the device is in a safety state (internal circuitries are on but all the outputs are off).
- From 3.9 V to 5.5 V (Functionalities during Crank phase):
 - Reset function; VDD > 3.3 V (rds-on state) I_{VDD} = 100 mA; 3.3 V < VDD_TRK < VDD (rds-on state);
 - Low-sides, K-Line, H-Bridge OFF if Reset = 0; SPI not available, internal registers resetted if Reset = 0;
 - All Diagnosis disabled if Reset = 0; VRS function limited (V_{diff max} = 1000 mV)
- From 5.5 V to 6 V (low battery):
 - All the functions are granted with the following degraded parameters; VDD > 4.510 V; Tracking error < 100 mV (I_{load} = 40 mA, rds-on state).
- From 6 V to 18 V: normal operating range
- From 18 V to V_{B_off}:
 - All the functions are granted with increased power dissipation and no reset is asserted during transient.
- From V_{B_off} to 40 V (internal circuitries are on but all the outputs are off):
 - The device is on and in a safety state.

2.2 Absolute maximum ratings

Maximum ratings are absolute ratings; exceeding any one of these values may cause permanent damage to the integrated circuit.

Table 3. Absolute maximum ratings

Parameter	Condition	Min	Max	Unit
DC supply voltage	pin VB/VB_1	-0.3	40	V
I/O low voltage pins ⁽¹⁾	-	-0.3	7	V
I/O low voltage digital pins ⁽²⁾	-	-0.3	VDD+0.3	V
I/O power pins voltage range ⁽³⁾	-	-0.3	Clamp voltage	V
TACH pin	-	-0.3	40	V
OUTA-D	-	-0.3	VB +0.3	V

Parameter	Condition	Min	Max	Unit
KEY pin	To be protected with R_key to limit sourced/ sunked current to ± 5 mA in dc conditions and ± 20 mA during transients (ISO-pulses on battery line)	-0.3	10	V
VRIN- / VRIN+	Max current [20 mA] to be limited with external resistors	-0.3	VDD + 0.3	V
VDD_TRK pin	-	-2	40	V
KL_LINE pin	-	-16	40	V
Maximum voltage shift between GND pins	PIN GND, GND_O2H, GND_P_1,2, GND_INJ1,2, GNDA, GNDP	-0.3	0.3	V
I/O power pins ⁽³⁾ maximum energy (single pulse, max. current)	Injector drivers	-	50	mJ
	O2 sensor heater	-	60	mJ
	Relay/current limited drivers	-	25	mJ
I/O power pins ⁽³⁾ maximum energy (continuous pulse, max. current, 36 million pulses with T = 100 ms)	Injector drivers	-	18	mJ
	O2 sensor heater	-	22	mJ
	Relay/current limited drivers	-	8	mJ
Reverse current through O2H output without supply voltage ⁽⁴⁾	Static (room temperature, max reverse diode voltage 1.5 V)	-	2.5	A
	Dynamic (guarantee by iso-pulse test immunity on application board)	-	-	
Reverse current through INJx outputs without supply voltage ⁽⁴⁾	Static (room temperature, max reverse diode voltage 1.5 V)	-	2.2	A
	Dynamic (guarantee by iso-pulse test immunity on application board)	-	-	
Reverse current through L output without supply voltage ⁽⁴⁾	Static (room temperature, max reverse diode voltage 1.5 V)	-	1.2	A
	Dynamic (guarantee by iso-pulse test immunity on application board)	-	-	
Reverse current through RLYx outputs without supply voltage ⁽⁴⁾	Static (room temperature, max reverse diode voltage 1.5 V)	-	1.5	A
	Dynamic (guarantee by iso-pulse test immunity on application board)	-	-	
Reverse current through TACH output without supply voltage ⁽⁴⁾	Static (room temperature, max reverse diode voltage 1.5 V)	-	0.5	A
	Dynamic (guarantee by iso-pulse test immunity on application board)	-	-	

1. Pins are VDD, VDD_SB, REXT, DIR

2. Pins are CS, SCK, SI, SO, VROUT, RESET, PWM, EN, INO2H, ILS_TACH, IN, KL_TX, KL_RX

3. Pins are O2H, L, INJ1-2, REL1-2-3

4. Reverse battery connection, parameter not tested for info only

Table 4. ESD protection

Item	Condition	Min	Max	Unit
All pins ⁽¹⁾⁽²⁾	HBM	-2	2	kV
All pins	MM	-200	200	V
All pins	CDM (values for corner pins in brackets)	-500 / (-750)	500 / (750)	V

Item	Condition	Min	Max	Unit
Pins to connector ⁽³⁾	HBM	-4	4	kV

1. OUTA-D, TACH, O2H, L, INJ1-2, REL1-2-3 vs. GNDP2, GNDO2: -1.5 / 1.5 kV
2. OUTA-D, TACH, O2H, L, INJ1-2, REL1-2-3 vs. GNDP1: -1 / 1 kV
3. Pins are OUTA-D, TACH, O2H, L, INJ1-2, KEY, REL1-2-3, VB, KL_LINE, VDD_TRK all GND connected together. The device is AEC-Q100 compliant.

2.3 Latch-up test

According to JEDEC 78 class 2 level A.

2.4 Temperature ranges and thermal data

Table 5. Temperature ranges and thermal data

Symbol	Parameter	Min	Max	Unit
T _{amb}	Operating temperature (ECU environment)	-40	125	°C
T _j	Operating junction temperature	-40	150	°C
T _{stg}	Storage temperature	-40	150	°C
T _{ot}	Thermal shut-down temperature	155	200	°C
O _{Thys}	Thermal shut-down temperature hysteresis	10		°C
R _{Th j-amb}	Thermal resistance junction-to-ambient ⁽¹⁾		20	°C/W
R _{Th j-case}	Thermal resistance junction-to-case		2	°C/W

1. with 2s2p PCB thermally enhanced.

2.5 Electrical characteristics

V_B = 6 V to 18 V, T_{amb} = -40 °C to 125 °C.

2.5.1 Supply

Table 6. Supply electrical characteristics

Symbol	Parameter	Condition	Min	Typ	Max	Unit
V _B	Operating supply voltage range	-	6	-	18	V
V _{B_off}	Vbat switch off threshold voltage	-	30	32	34	V
V _{B_OVh}	Overvoltage threshold hysteresis	-	0.5	-	-	V
V _{B_UVL}	Undervoltage disable LOW threshold	-	3.5	3.7	3.9	V
V _{B_UVh}	Undervoltage threshold hysteresis	-	0.3	-	1	V
I _{VB(dis)}	Standby current from VB, VB_1	VB = VB_1 = 13 V, device disabled, KEY < 0.7 V	-	-	120	µA
I _{VB}	Quiescent current	VB = VB_1 = 13 V, outputs floating	-	-	20	mA
V _{rext}	ASIC Bias reference	Application info	-	1.22	-	V
f _{int_clk}	Internal clock reference	Application info	-	5.6	-	MHz
T _{dgc_VB_OV}	VB overvoltage shut-down filter time	Guaranteed by scan	22.5	30	37.5	µs
T _{dgc_VB_UV}	VB undervoltage shut-down filter time	Guaranteed by scan	0.8	1	1.2	µs

2.5.2 Key
Table 7. Key electrical characteristics

Symbol	Parameter	Condition	Min	Typ	Max	Unit
V_Key_L	Input level low	-	-	-	1.5	V
V_Key_H	Input level high	-	3.3	-	-	V
V_Key_Hyst	Input voltage hysteresis	-	0.5	-	1.8	V
R_Key	Internal pull down	-	50	150	300	kΩ
T_key_deglitch	Key input filter time	Guaranteed by scan	26	-	40	μs
T_key_delay	Maximum delay time from Key to regulator enable	Time from key rising edge to 20% VDD rising edge	-	-	200	μs

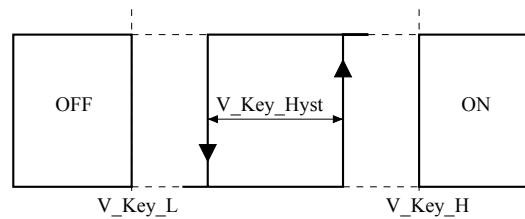
Figure 3. Input threshold

GADG1911180723PS

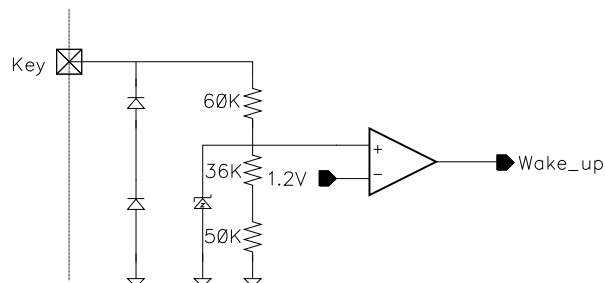
Figure 4. Key block diagram

GAPGPS00588

2.5.3 Digital pins
Table 8. Digital pins characteristics

Symbol	Parameter	Condition	Min	Typ	Max	Unit
V _{in_L}	Input level low	-	-	-	0.3*VDD	V
V _{in_H}	Input level high	-	0.7*VDD	-	-	V
V _{h in}	Input voltage hysteresis	-	0.1	-	-	V
R _{pull}	Internal pull-down/pull-up ⁽¹⁾⁽²⁾⁽³⁾	-	50	150	250	kΩ
I _{pull_down}	Active pull-down	-	10	-	100	μA

1. Pins with active pull-down: DIR.
2. Pins with pull-down: EN, PWM, ISL-TACH, INO2H, IN_REL1-2, IN1-2;
3. Pins with pull-up: SI, SCK, CS, KL-TX;

2.5.4 Digital output pins

Table 9. Digital output pins characteristics

Symbol	Parameter	Condition	Min	Typ	Max	Unit
	Output level low	$I_{\text{sink}} = 2\text{mA}$	-	-	0.4	V
	Output level high	$I_{\text{source}} = 2\text{mA}$ ⁽¹⁾⁽²⁾	VDD-0.5	-	-	V

1. Pins with push-pull stage and tri-state condition: SDO

2. Pins with open drain output: RESET, VROUT;

2.5.5 5 V voltage regulator

Table 10. VDD output electrical characteristics

Symbol	Parameter	Condition	Min	Typ	Max	Unit
VDD	Output voltage	-	4.9	5	5.1	V
Ln_vdd	Line regulation	$V_B = 6\text{ V to }18\text{ V}$ $I_{\text{load}} = 150\text{ mA}$	-25	-	25	mV
Ld_vdd	Load regulation	$V_B = 13\text{ V}$ $I_{\text{load}} = 5\text{ mA to }300\text{ mA}$	-25	-	25	mV
V _{dd_OS}	Max overshoot	Recovery from ISO pulse stimuli on battery line (guaranteed by design)	-	-	5.5	V
V _{dd_SR}	Voltage slew-rate at power-on	$C_{\text{load}} = 4.7\text{ }\mu\text{F}$	2	-	25	V/ms
I _{dd}	Load current	-	5	-	300	mA
I _{dd_max}	Current limitation	Output short to 4 V	350	-	600	mA
I _{dd_STG}	Short to ground current limitation	Output shorted to GND	350	-	700	mA
PSRR	Power supply rejection ratio	Sin wave @ 1 kHz 1 V _{pp} ; $V_B = 13\text{ V}$; $I_{\text{load}} = 5\text{ mA to }300\text{ mA}$	40	-	-	dB
V _{dr5}	$V_B - V_{\text{dd}} - V_{\text{dd dropout}}$ voltage	$V_B = 5\text{ V}$; $I_{\text{load}} = 300\text{ mA}$	0.30	-	0.75	V
Tdcg_VDD	VDD thermal shutdown filter time	Guaranteed by scan	22.5	30	37.5	μs

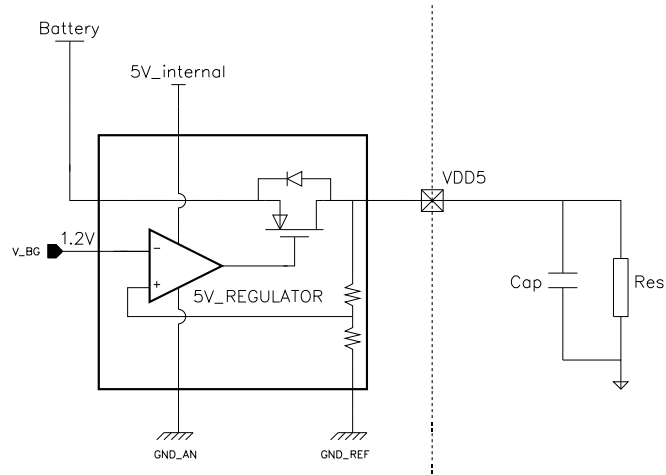
Figure 5. 5 V main regulator block diagram

GADG0412171216PS

2.5.6 Reset

Table 11. Reset function electrical characteristics

Symbol	Parameter	Condition	Min	Typ	Max	Unit
VUV_LO	Output low voltage	$1 < VDD < V_{th_UV}$, $I_{reset} = 2 \text{ mA}$	-	-	0.6	V
IUV_LO	Reset current capability	$1 < VDD < V_{th_UV}$, $V_{reset} = 0.6 \text{ V}$	2	-	-	mA
I_{lk}	Leakage current	$VUV_{reset} = 4.5 \text{ V}$	-	-	1	μA
Vth_UV	VDD under voltage low threshold	$V_B = 13.5 \text{ V}$	4.5	-	$VDD - 150 \text{ mV}$	V
Vth_UV Tht	VDD under voltage high threshold	-	4.5	-	$VDD - 50 \text{ mV}$	V
Vth_UV HYS	VDD under voltage hysteresis	-	50	-	-	mV
Td_UV_rst	Power on UV reset delay	-	17	22	30	ms
TfUV_reset	UV reset filter	$VDD < V_{th_UV}$	25	50	75	μs

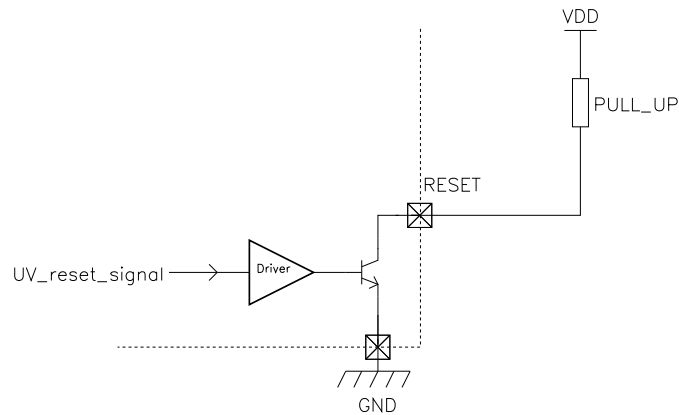
Figure 6. Reset

GAPGPS00590

2.5.7 5 V tracking voltage regulator
Table 12. VDD_TRK output electrical characteristics

Symbol	Parameter	Condition	Min	Typ	Max	Unit
DV_{ddtrk}	Output voltage tracking error	$V_B = 6\text{ V}$, $I_{trk} = 1\text{ to }40\text{ mA}$	-15	-	15	mV
V_{short}	Tracking output short circuit voltage range	-	-2	-	V_B	V
I_{trk_max}	Output current limitation	Output short to 4 V	50	-	100	mA
I_{trk_sb}	Tracking output reverse current (limited by the regulator)	Output shorted to $V_B = 16\text{ V}$	-	-	10	mA
I_{dd}	Load current	-	1	-	40	mA
Ln_{vdd_trk}	Line regulation	$V_B = 6\text{ V to }18\text{ V}$ - $I_{load} = 40\text{ mA}$	-15	-	15	mV
Ld_{vdd_trk}	Load regulation	$V_B = 13\text{ V}$ $I_{load} = 1\text{ to }40\text{ mA}$	-15	-	15	mV
PSRR	Power supply rejection ratio	Sin wave @ 1 kHz 1 Vpp $V_B = 13\text{ V}$, $I_{load} = 1\text{ to }40\text{ mA}$	40	-	-	dB

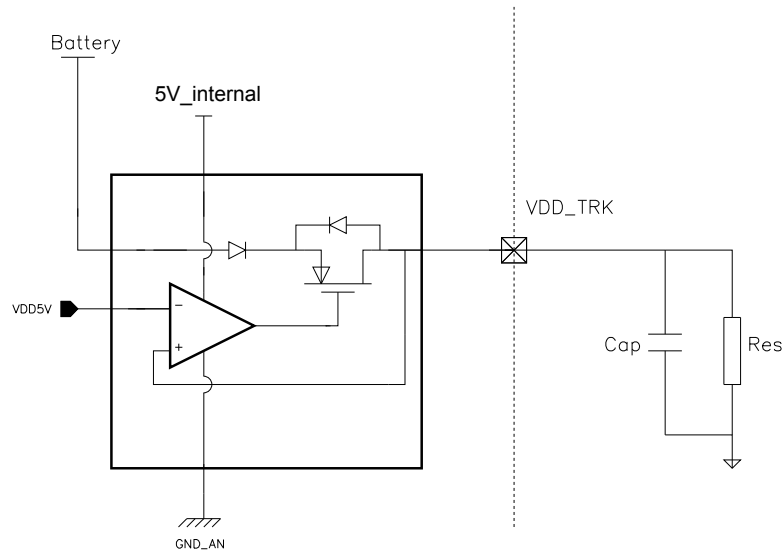
Figure 7. 5 V tracking regulator block diagram

GADG0412171138PS

2.5.8 Standby regulator
Table 13. VDD_SB output electrical characteristics

Symbol	Parameter	Condition	Min	Typ	Max	Unit
V_{ddsb}	Output voltage	-	4.75	5	5.25	V
Ln_{vsb}	Line regulation	$V_B = 6\text{ V to }18\text{ V}$ $I_{load} = 1\text{ mA}$	-25	-	25	mV
Ld_{vsb}	Load regulation	$V_B = 13\text{ V}$ $I_{load} = 0.1\text{ mA to }2.5\text{ mA}$	-25	-	25	mV
V_{dd_OS}	Max overshoot	-	-	-	5.5	V
I_{dd}	Load current	-	0.1	-	2.5	mA

Symbol	Parameter	Condition	Min	Typ	Max	Unit
I_{sb_max}	Current limitation	Output short to 4 V	5	-	50	mA
V_{sb_SR}	Voltage slew-rate at power on	$C_{load} = 1 \mu F$	2	-	30	V/ms
PSRR	Power supply rejection ratio	Sin wave @ 1 kHz 1 Vpp $V_B = 13 V$ $I_{load} = 0.1$ to 1 mA	40	-	-	dB

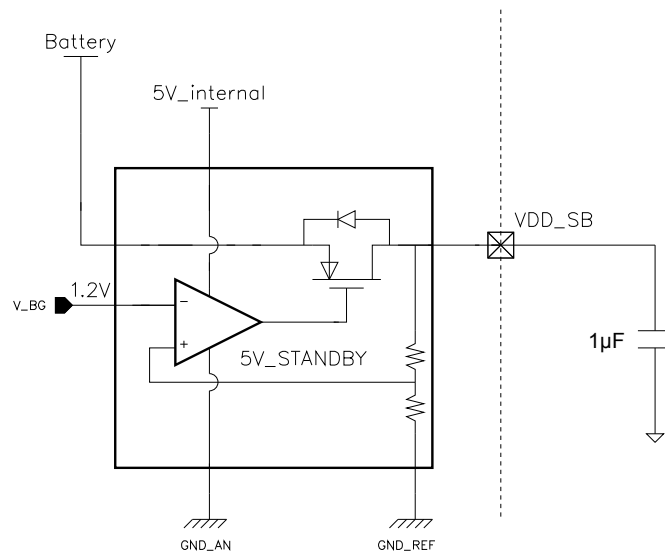
Figure 8. 5 V standby regulator block diagram

GAPGPS00592

2.5.9 High side switch

Table 14. HS_OUT output electrical characteristics

Symbol	Parameter	Condition	Min	Typ	Max	Unit
R_{on_hs}	Ron	$I_{hs} = 50 \text{ mA}$	-	-	14	Ω
I_{hs_max}	Current limitation	$V_B = 13.5 V$	100	-	400	mA

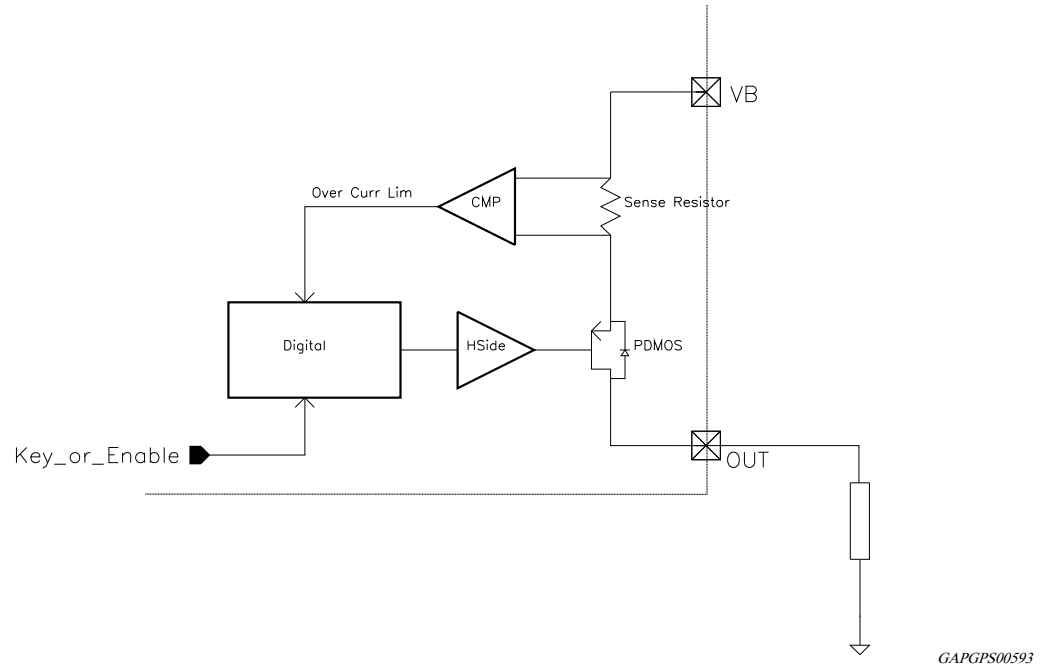
Figure 9. High-side driver block diagram

GAPGPS00593

The High side switch is intended as a protected battery and is directly controlled by key input (see [Figure 21](#)).

2.5.10 Injector driver

Table 15. Injector driver electrical characteristic

Symbol	Parameter	Condition	Min	Typ	Max	Unit
I_{max}	Output current	-	-	-	2.2	A
I_{oc}	Overcurrent threshold	-	2.8	-	5	A
V_{DS}	Output clamping voltage	$I = 2.2 \text{ A}$	55	-	65	V
R_{on}	On resistance	$I = 2.2 \text{ A}$	-	-	0.6	Ω
I_{lk_off}	Leakage current	$V_{out} = 18 \text{ V}, \text{Key} = 0 \text{ V}$	-	-	10	μA
I_{lk_on}	Pull-Down diagnosis current	$V_{out} = 18 \text{ V}, \text{Key} = 5 \text{ V}$	-	-	100	μA
t_{on-off}	Turn on-off delay	from CMD edge to 50% output variation	-	-	6	μs
V_{OL}	Open load output voltage	Driver in OFF condition	$0.46 \cdot V_{DD}$	$0.5 \cdot V_{DD}$	$0.54 \cdot V_{DD}$	V
$V_{diag_H}^{(1)}$	Diagnostic high threshold	Driver in OFF condition	$0.54 \cdot V_{DD}$	$0.6 \cdot V_{DD}$	$0.66 \cdot V_{DD}$	V
$V_{diag_L}^{(1)}$	Diagnostic low threshold	Driver in OFF condition	$0.36 \cdot V_{DD}$	$0.4 \cdot V_{DD}$	$0.44 \cdot V_{DD}$	V
Tmask	OFF diagnostic masking time	Guaranteed by scan	0.75	1	1.25	ms
Tdcg_noise	OFF diagnostic Deglitch filter time	Guaranteed by scan	2.16	3.6	5.04	μs
Tdcg	ON diagnostic Deglitch filter time	Guaranteed by scan	15	20	25	μs

1. $V_{diag_L} < V_{out} < V_{diag_H} \rightarrow$ Open Load; $V_{out} < V_{diag_L} \rightarrow$ Short to GND

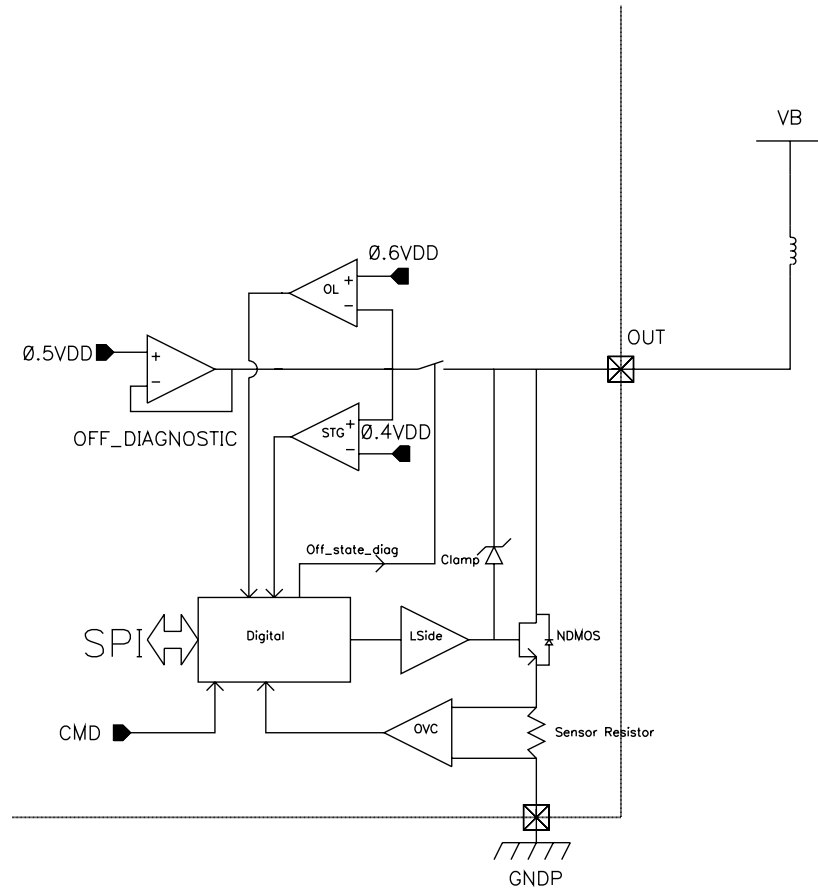
Figure 10. Low-side driver block diagram

GAPGPS00594

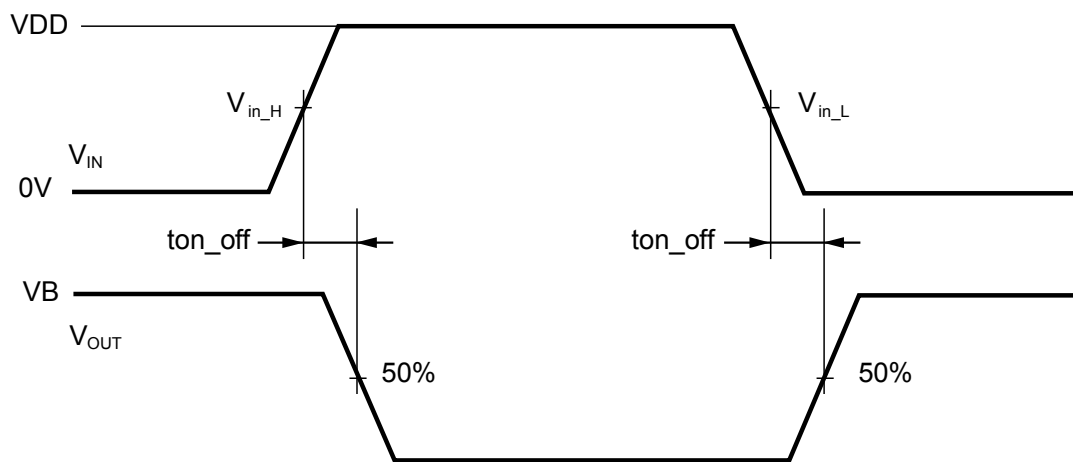
Figure 11. Low-side timing diagram (injectors, relays, current limited LSD, tach, O2H)

GADG0412170937PS

2.5.11 Relay drivers
Table 16. Relay driver characteristics

Symbol	Parameter	Condition	Min	Typ	Max	Unit
I_{max}	Output current	-	-	-	1	A
I_{oc}	Overcurrent threshold	-	1.2	-	2.5	A
V_{DS}	Output clamping voltage	$I = 1\text{ A}$	40	-	50	V
R_{on}	On resistance	$I = 1\text{ A}$	-	-	1.5	Ω
I_{lk_off}	Leakage current	$V_{out} = 18\text{ V}, \text{Key} = 0\text{ V}$	-	-	10	μA
I_{lk_on}	Pull-Down diagnosis current	$V_{out} = 18\text{ V}, \text{Key} = 5\text{ V}$	-	-	100	μA
t_{on_off}	Turn on-off delay	From CMD (serial or parallel) rising edge	-	-	6	μs
V_{OL}	Open load output voltage	Driver in OFF condition	$0.46 \cdot V_{DD}$	$0.5 \cdot V_{DD}$	$0.54 \cdot V_{DD}$	V
$V_{diagth_H}^{(1)}$	Diagnostic high threshold	Driver in OFF condition	$0.54 \cdot V_{DD}$	$0.6 \cdot V_{DD}$	$0.66 \cdot V_{DD}$	V
$V_{diagth_L}^{(1)}$	Diagnostic low threshold	Driver in OFF condition	$0.36 \cdot V_{DD}$	$0.4 \cdot V_{DD}$	$0.44 \cdot V_{DD}$	V
Tmask	OFF diagnostic masking time	Guaranteed by scan	2.63	3.5	4.38	ms
Tdcg_noise	OFF diagnostic Deglitch filter time	Guaranteed by scan	2.16	3.6	5.04	μs
Tdcg	ON diagnostic Deglitch filter time	Guaranteed by scan	15	20	25	μs

1. $V_{diagth_L} < V_{out} < V_{diagth_H} \rightarrow$ Open Load; $V_{out} < V_{diagth_L} \rightarrow$ Short to GND

2.5.12 Current limited low side driver (LSD)
Table 17. Current limited LSD driver characteristics

Symbol	Parameter	Condition	Min	Typ	Max	unit
I_{LI}	Linear current limitation	$V_B = 18\text{ V}, \text{settling time} = 300\ \mu\text{s}$	2	-	2.45	A
I_{oc}	Overcurrent threshold	Masked for driver during in-rush	1.2	-	1.95	A
t_{dgmsk}	Diagnosis masking time in OFF condition	Guaranteed by scan	2	-	5	ms
V_{DS}	Output clamping voltage	$I = 200\text{ mA}$	40	-	50	V
R_{on}	On resistance	$I = 200\text{ mA}$	-	-	1.5	Ω
I_{lk_off}	Leakage current	$V_{out} = 18\text{ V}, \text{Key} = 0\text{ V}$	-	-	10	μA
I_{lk_on}	Pull-Down diagnosis current	$V_{out} = 18\text{ V}, \text{Key} = 5\text{ V}$	-	-	100	μA
t_{on_off}	Turn on-off delay	From SPI CS rising edge	-	-	6	μs
V_{OL}	Open load output voltage	Driver in OFF condition	$0.46 \cdot V_{DD}$	$0.5 \cdot V_{DD}$	$0.54 \cdot V_{DD}$	V
$V_{diagth_H}^{(1)}$	Diagnostic high threshold	Driver in OFF condition	$0.54 \cdot V_{DD}$	$0.6 \cdot V_{DD}$	$0.66 \cdot V_{DD}$	V
$V_{diagth_L}^{(1)}$	Diagnostic low threshold	Driver in OFF condition	$0.36 \cdot V_{DD}$	$0.4 \cdot V_{DD}$	$0.44 \cdot V_{DD}$	V
Tmask	OFF diagnostic masking time	Guaranteed by scan	2.63	3.5	4.38	ms
Tdcg_noise	OFF diagnostic Deglitch filter time	Guaranteed by scan	2.16	3.6	5.04	μs
Tdcg	ON diagnostic Deglitch filter time	Guaranteed by scan	15	20	25	μs
Tmask_rush	ON diagnostic inrush current mask time	Guaranteed by scan	252	336	420	μs

1. $V_{diag_L} < V_{out} < V_{diag_H} \rightarrow$ Open Load; $V_{out} < V_{diag_L} \rightarrow$ Short to GND

2.5.13 Tachometer driver

Table 18. Tachometer driver electrical characteristics

Symbol	Parameter	Condition	Min	Typ	Max	Unit
I_{oc}	Overcurrent threshold	-	100	-	500	mA
R_{on}	On resistance	$I = 25$ mA	-	-	5	Ω
I_{lk_off}	Leakage current	$V_{out} = 18$ V, Key = 0 V	-	-	10	μ A
I_{lk_on}	Pull-Down diagnosis current	$V_{out} = 18$ V, Key = 5 V	-	-	100	μ A
t_{on_off}	Turn on-off delay	From CMD (serial or parallel) rising edge	-	-	6	μ s
V_{OL}	Open load output voltage	driver in OFF condition	$0.46 \cdot V_{DD}$	$0.5 \cdot V_{DD}$	$0.54 \cdot V_{DD}$	V
$V_{diag_H}^{(1)}$	Diagnostic high threshold	Driver in OFF condition	$0.54 \cdot V_{DD}$	$0.6 \cdot V_{DD}$	$0.66 \cdot V_{DD}$	V
$V_{diag_L}^{(1)}$	Diagnostic low threshold	Driver in OFF condition	$0.36 \cdot V_{DD}$	$0.4 \cdot V_{DD}$	$0.44 \cdot V_{DD}$	V
Tmask	OFF diagnostic masking time	Guaranteed by scan	0.75	1	1.25	ms
Tdcg_noise	OFF diagnostic Deglitch filter time	Guaranteed by scan	2.16	3.6	5.04	μ s
Tdcg	ON diagnostic Deglitch filter time	Guaranteed by scan	15	20	25	μ s

1. $V_{diag_L} < V_{out} < V_{diag_H} \rightarrow$ Open Load; $V_{out} < V_{diag_L} \rightarrow$ Short to GND

2.5.14 Stepper motor driver

Table 19. Stepper motor driver electrical characteristics

Symbol	Parameter	Condition	Min	Typ	Max	Unit
I_{oc}	Overcurrent threshold	ON condition	0.85	-	2	A
R_{dsON}	On resistance HS+LS	$I_{out} = 0.5$ A, $T_j = 150$ °C, $V_B = 14$ V	-	-	2.6	Ω
$f_{stepper}$	Working frequency	Application info	-	-	20	kHz
$V_{out_off}^{(1)(2)(3)}$	OUTA_B_C_D output voltage	OUTA short to OUTB; OUTC short to OUTD; Stepper driver disable	$0.44 \cdot V_{DD}$	$0.5 \cdot V_{DD}$	$0.54 \cdot V_{DD}$	V
V_{diag_H}	Diagnostic high threshold	Driver in OFF condition	$0.54 \cdot V_{DD}$	$0.6 \cdot V_{DD}$	$0.66 \cdot V_{DD}$	V
V_{diag_L}	Diagnostic low threshold	Driver in OFF condition	$0.36 \cdot V_{DD}$	$0.4 \cdot V_{DD}$	$0.44 \cdot V_{DD}$	V
I_{DSS_OUT}	Output leakage current	Driver in OFF condition	-	-	10	μ A
t_{scvb}	Over current switch_off time	Guaranteed by scan	-	-	25	μ s
t_{rb}	Rise output time	$V_B = 12$ V, $R_I = 39$ Ω	-	-	15	μ s
t_{fb}	Fall output time	$V_B = 12$ V, $R_I = 39$ Ω	-	-	15	μ s
t_{rb-a}	Rise output time	$T_{amb} = 25$ °C,	-	-	10	μ s
t_{fb-a}	Fall output time	$V_B = 12$ V, $R_I = 39$ Ω	-	-	10	μ s
t_{pHLb}	Turn-off in/out delay time	$V_B = 12$ V, $R_I = 39$ Ω	-	-	15	μ s
t_{pLHb}	Turn-off in/out delay time	$V_B = 12$ V, $R_I = 39$ Ω	-	-	15	μ s
$V_{reverse_HS}$	Reverse HS diode drop	Driver in OFF condition $I_{injected} = 0.5$ A	-	-	1.5	V
$V_{reverse_LS}$	Reverse LS diode drop	Driver in OFF condition $I_{sourced} = 0.5$ A	-	-	-1.5	V

Symbol	Parameter	Condition	Min	Typ	Max	Unit
Tdgc_step_OFF	OFF Diagnostic Deglitch filter time	Guaranteed by scan	93.8	125	156.3	μ s
Tmask	Masking time	Guaranteed by scan	0.75	1	1.25	ms
Tdgc_step_ON	ON Diagnostic Deglitch filter time	Guaranteed by scan	15	20	25	μ s

- $V_{outA} < V_{diagth_H}$ and $V_{outB} > V_{diagth_L}$ or $V_{outC} < V_{diagth_H}$ and $V_{outD} > V_{diagth_L} \rightarrow$ No Fault
- $V_{outA_B_C_D} < V_{diagth_L} \rightarrow$ Short to GND
- $V_{outA} > V_{diagth_H}$ and $V_{outB} < V_{diagth_L}$ or $V_{outC} > V_{diagth_H}$ and $V_{outD} < V_{diagth_L} \rightarrow$ Open load
 $V_{outA_B_C_D} > V_{diagth_H} \rightarrow$ Short to Battery

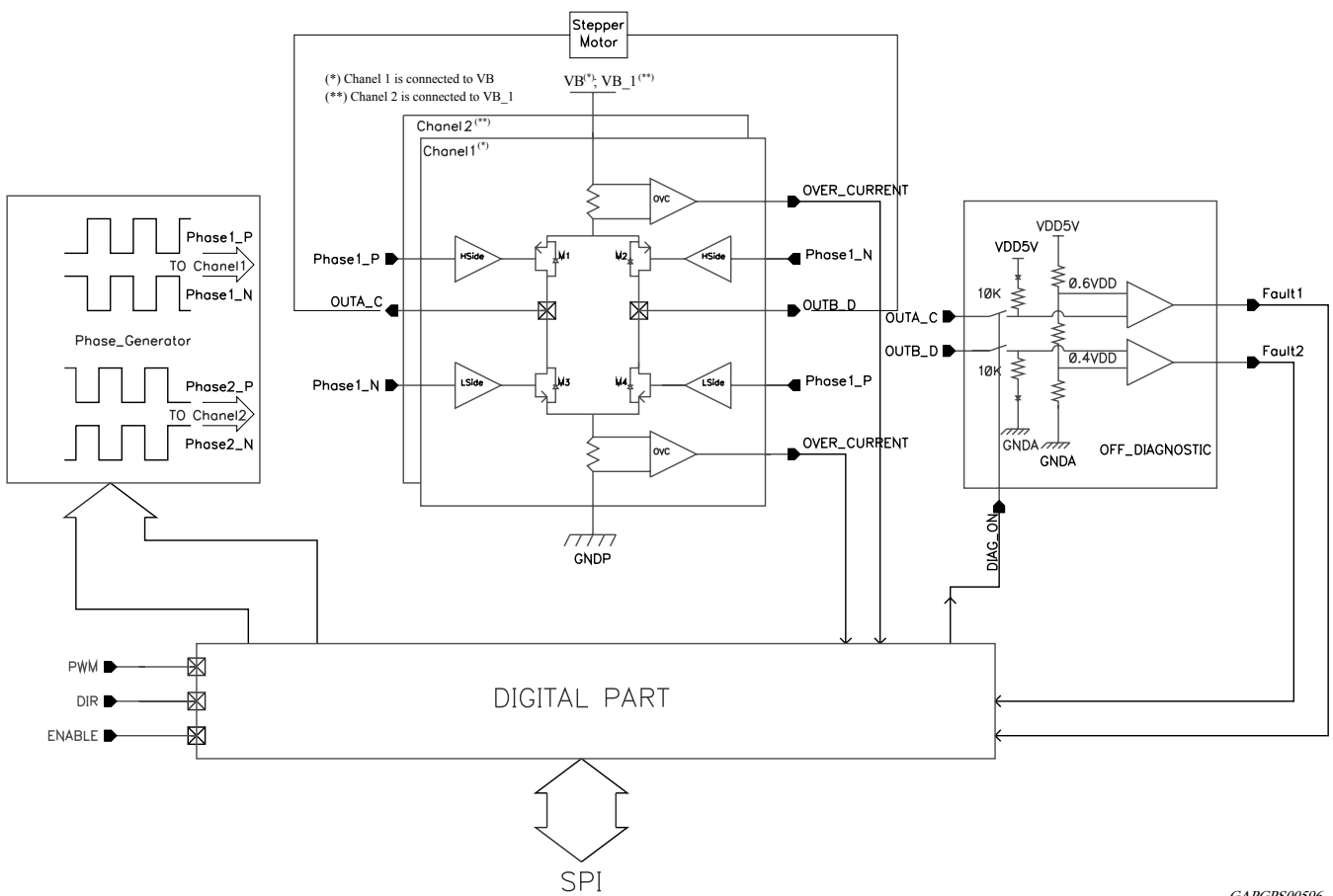
Figure 12. Stepper motor driver block diagram

GAPGPS00596

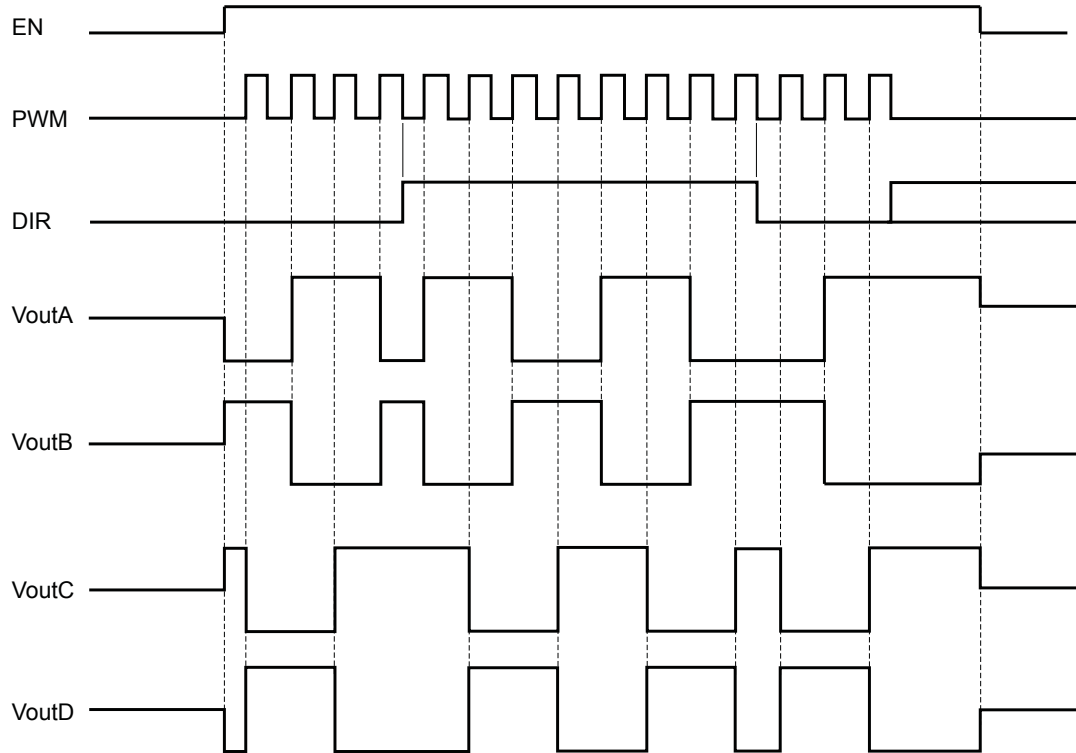
Figure 13. Stepper motor operations

GADG2408171141PS

2.5.15 O2 sensor heater driver
Table 20. O2 sensor heater driver characteristics

Symbol	Parameter	Condition	Min	Typ	Max	Unit
R_{dsON}	On resistance	$I_{out} = 3\text{ A}$	-	-	0.5	Ω
V_C	Output clamping voltage	$I_{out} = 3\text{ A}$	40	-	50	V
I_{lk_off}	Leakage current	$V_{out} = 18\text{ V}, \text{Key} = 0\text{ V}$	-	-	10	μA
I_{lk_on}	Pull-Down diagnosis current	$V_{out} = 18\text{ V}, \text{Key} = 5\text{ V}$	-	-	100	μA
t_{on_off}	Turn on-off delay	From CMD (serial or parallel) rising edge	-	-	6	μs
V_{OL}	Open load output voltage	Driver in OFF condition	$0.46 \cdot V_{DD}$	$0.5 \cdot V_{DD}$	$0.54 \cdot V_{DD}$	V
I_{OC}	Overcurrent threshold		3.8	-	5	A
$V_{diagH_H}^{(1)}$	Diagnostic high threshold	Driver in OFF condition	$0.54 \cdot V_{DD}$	$0.6 \cdot V_{DD}$	$0.66 \cdot V_{DD}$	V
$V_{diagH_L}^{(1)}$	Diagnostic low threshold	Driver in OFF condition	$0.36 \cdot V_{DD}$	$0.4 \cdot V_{DD}$	$0.44 \cdot V_{DD}$	V
Tmask	OFF diagnostic masking time	Guaranteed by scan	0.75	1	1.25	ms
Tdcg_noise	OFF diagnostic Deglitch filter time	Guaranteed by scan	2.16	3.6	5.04	μs
Tdcg	ON diagnostic Deglitch filter time	Guaranteed by scan	15	20	25	μs

 1. $V_{diagH_L} < V_{out} < V_{diagH_H} \rightarrow$ Open Load; $V_{out} < V_{diagH_L} \rightarrow$ Short to GND

2.5.16 Variable reluctance sensor interface
Table 21. Variable reluctance sensor interface electrical characteristics

Symbol	Parameter	Condition	Min	Typ	Max	Unit
V_{HTH}	Input high to low differential threshold voltage at VRIN+ and VRIN- nodes	-	-50	-	50	mV
V_{CM}	Common mode operating range at VRIN+ and VRIN-	-	0	1.5	3	V
$V_{cm_internal}$	Internal common mode voltage	Switch off hysteresis current	$0.27 \cdot V_{DD}$	$0.3 \cdot V_{DD}$	$0.33 \cdot V_{DD}$	V
$V_{diagth_H}^{(1)}$	Diagnostic high threshold	Diagnostic voltage referred to VRIN- (see Figure 14)	$0.67 \cdot V_{DD}$	$0.75 \cdot V_{DD}$	$0.82 \cdot V_{DD}$	V
$V_{diagth_L}^{(1)}$	Diagnostic low threshold		$0.18 \cdot V_{DD}$	$0.2 \cdot V_{DD}$	$0.22 \cdot V_{DD}$	V
I_{diag}	Diagnostic current	Current from VRIN- when diagnostic on	35	50	65	μA
$R_{internal_common}$	Internal common mode resistor	Switch off hysteresis current	50	200	350	k Ω
I_{IB}	Input bias current	$VRIN+ = VRIN- = 1.5 V$	-	-	2	μA
I_{leak}	Output leakage	$V_{ROUT} = 5 V$	-	-	1	μA
V_{CLPH}	Input high clamping voltage	$VRIN+ = VRIN- = 20 mA$	-	5	-	V
V_{CLPL}	Input low clamping voltage	$VRIN+ = VRIN- = 20 mA $	-1.5	-	-0.3	V
t_{of}	Output fall time	$C_{LOAD} = 20 pF, R_{LOAD} = 5 k\Omega$	-	-	300	ns
t_{of_1nf}	Output fall time	$C_{LOAD} = 1 nF$	-	-	1.5	μs
V_{OUTL}	Output buffer low voltage	$I_{sink} = 2 mA$	-	-	0.6	V
I_{OUTL}	Output current capability	$V_{out} = 0.6 V$	2	-	-	mA
t_{prop}	Propagation delay	VRS INM = 0.5 V, INP applied to 1 V to make VRS OUT commuted	0.1	0.45	0.8	μs
Tdgc_VRS	OFF Diagnostic Deglitch filter time	Guaranteed by scan	24	30	36	μs

1. if $(VRIN- > V_{diagth_H})$ or $(VRIN- < V_{diagth_L})$ then Fault is detected.

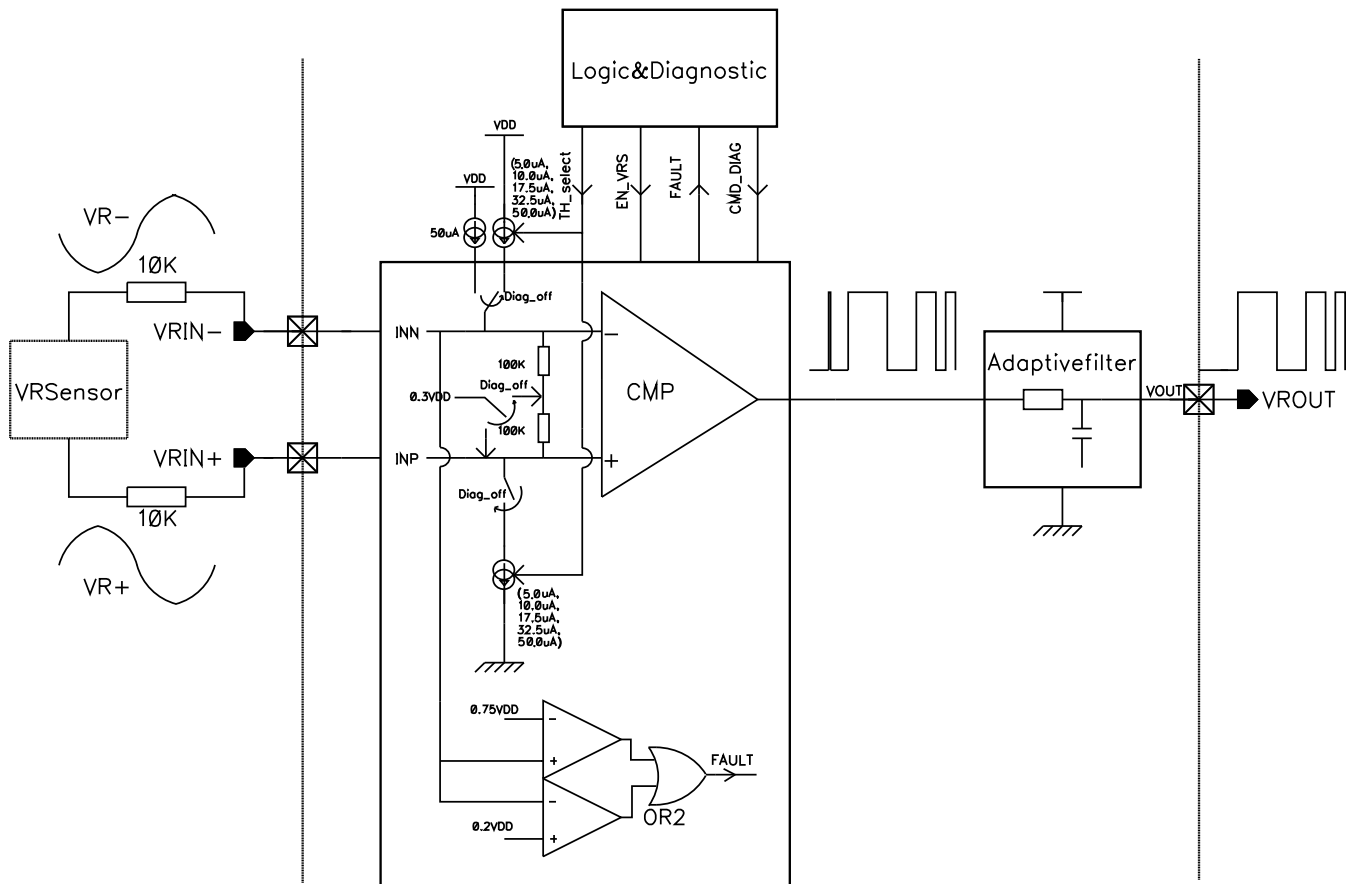
Figure 14. VRS block diagram

GAPGS00598

2.5.17 K-line
Table 22. K-Line interface electrical characteristics

Pin	Symbol	Parameter	Test conditions	Min.	Typ.	Max.	Unit
KL_TX	ITXsource	Transmitter input source current	-	10	-	100	μ A
	ITXsink	Transmitter input sink current	KL_TX = VDD	-	-	2.1	μ A
	IKL_TX	KL_TX Internal Pull-up	-	-	200	-	k Ω
K_LINE	VKoutL	Transmitter output low voltage	IsinkK_LINE = 35 mA, KL_TX = Low	-1	-	1.5	V
	VKinH	Receiver input high voltage	-	0.7xVB	-	VB	V
	VKinL	Receiver input low voltage	-	-1	-	0.35xVB	V
	VKH	Receiver input hysteresis	-	0.05xVB	-	0.3xVB	V
	IKleak	Receiver leakage current	KL_LINE = VB, KL_TX = High	-	-	1	μ A
K_LINE	IKshort	Transmitter short circuit current	KL_LINE = VB, KL_TX = Low	60	-	-	mA
	IKrev	Reverse battery or GND loss current	ENABLE = KEY = VB = 0 V, KL_LINE = -13.5	-	-	10	mA
	IKpull-up	KLINE internal pull-up	KL_TX = High	60	-	140	k Ω
	IKuv	Under voltage current	KEY = High, KL_TX = Low, VB = 13.5 V, KL_LINE = -1 V	-	-	1	mA

Pin	Symbol	Parameter	Test conditions	Min.	Typ.	Max.	Unit
KL_RX	VRXoutL	KL_RX output low voltage	$I_{\text{sink}} = 0.4 \text{ mA}$	-	-	0.4	V
KL_TX to K_LINE	Tp_HLT	Transmitter turn-on delay time	CKline = 10 nF, RKline = 510 Ω	-	-	5	μs
K_LINE	T_fT	Transmitter fall time	CKline = 10 nF, RKline = 510 Ω	-	-	10	μs
KL_LINE to KL_RX	TpR	Receiver turn-on delay time	$C_{\text{load}} = 20 \text{ pF}$, RPKL_Rx = 2 k Ω	-	-	4	μs
KL_RX	T_fR	Receiver fall time	$C_{\text{load}} = 20 \text{ pF}$, RPKL_Rx = 2 k Ω	-	-	2	μs
	T_rR	Receiver rise time	$C_{\text{load}} = 20 \text{ pF}$, RPKL_Rx = 2 k Ω	-	-	2	μs
K_LINE	fMax	Max transmission Operating frequency	Application info	-	-	60	kHz

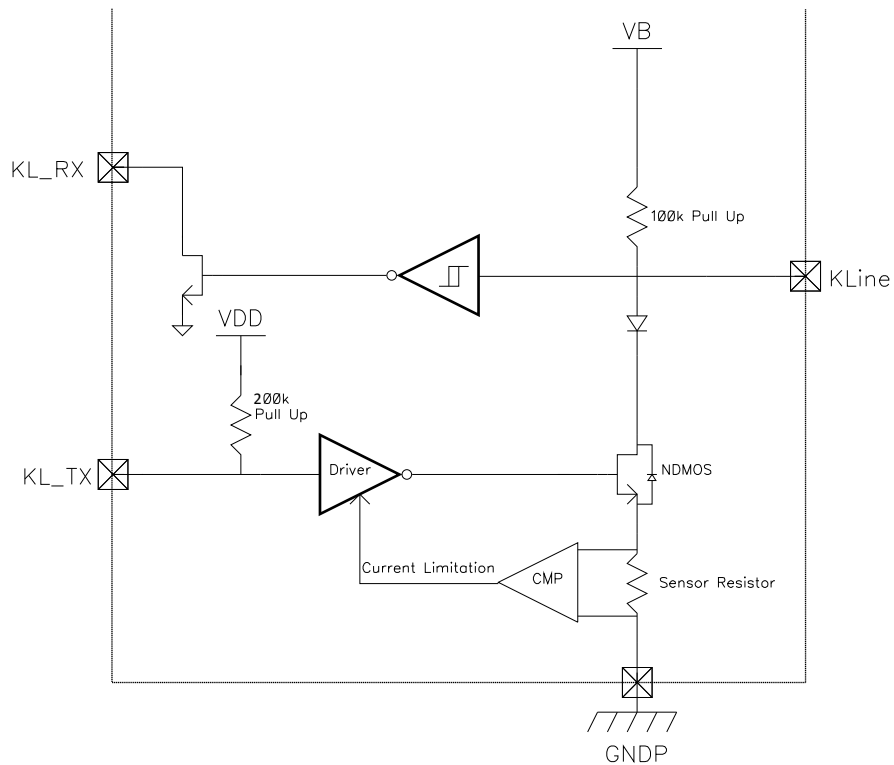
Figure 15. K-line block diagram

GAPGPS00599
2.5.18 SPI interface
Table 23. SPI characteristics and timings

Symbol	Parameter	Test conditions	Min	Typ	Max	Unit
SiCin	Input capacitance	-	-	-	20	pF
SCKCin		-	-	-	20	pF
t _{sckcs}	Clock inactive time before frame	-	100	-	-	ns

Symbol	Parameter	Test conditions	Min	Typ	Max	Unit
t_{CSSO}	Access time	See ⁽¹⁾	-	-	500	ns
t_{SOdis}	Output data (SO) disable time	No Capacitor on SO, See ⁽²⁾	-	-	500	ns
t_{lead}	Channels select (CS) lead time	See ⁽¹⁾	500	-	-	ns
t_{SCKFSO}	Output valid time	See ⁽¹⁾ , @ $f_{CLK}= 5.4$ MHz	60	-	-	ns
t_{SOCS}	Output data (SO) disable time	No capacitor on SO, see ⁽¹⁾	-	-	500	ns
$t_{SIsetup}$	Input data (SI) set-up time	@ $f_{CLK}= 5.4$ MHz	20	-	-	ns
t_{SIhold}	Input data (SI) hold time	@ $f_{CLK}= 5.4$ MHz	20	-	-	ns
t_{SCK}	CLK period	-	185	-	-	ns
t_{CSsck}	Clock inactive time after frame	-	600	-	-	ns
t_{CSN}	CS de asserted time	-	600	-	-	ns

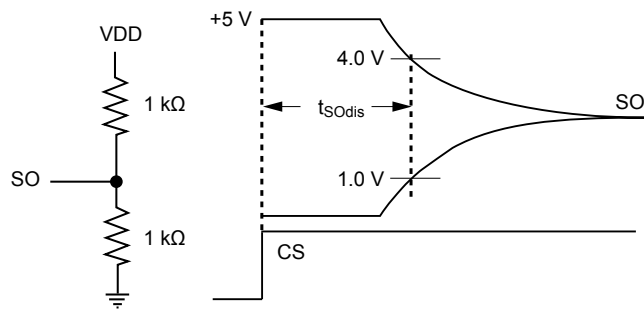
- see Figure 17. SPI timing diagram
- see Figure 16. SO loading for disable time measurement

Figure 16. SO loading for disable time measurement

GADG0412170958PS

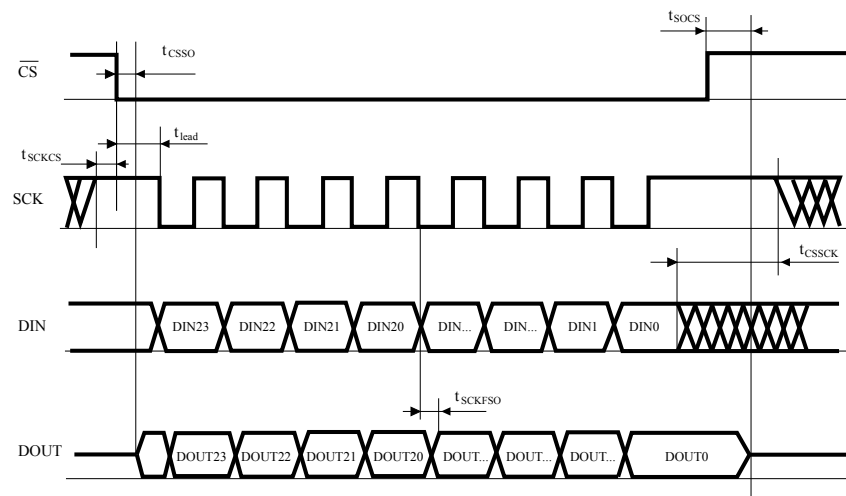
Figure 17. SPI timing diagram

GADG0412171035PS

3 Functional description

3.1 Chip working conditions

Table 24. A outputs working conditions

-	Standby	Run mode	VB_OV	VB_UV	Reset	Over current	Thermal warning
VDD_SB regulator	ON	ON	ON	ON	ON	Current limitation	ON
VDD regulator	OFF	ON	OFF	OFF	ON	Current limitation	OFF if linked with VDD current limitation
VDD_TRK regulator	OFF	ON	OFF	OFF	ON	Current limitation	OFF if linked with VDD_TRK current limitation
All LS drivers	OFF	ON	OFF	OFF	OFF	Over current switch off	ON
Diagnostics of all LS drivers	OFF	ON	OFF	OFF	ON ⁽¹⁾	-	ON
HS Driver	OFF	ON	OFF	OFF	OFF	Current limitation	ON
Stepper Motor Driver	OFF	ON	OFF	OFF	OFF	Over current switch off	ON
K-line Transceiver	OFF	ON	OFF	OFF	OFF	Current limitation	ON
VRS	OFF	ON	OFF	OFF	OFF	-	ON
SPI	Default	Default	Default	Default	Default	ON	ON

1. The diagnostic currents and comparator are switched on in reset condition.

3.2 Chip bias current generation

The Internal current generator circuit is buffering internal band-gap voltage (1.2 V typ.) on a high precision external resistor (10 kΩ ±1 %) and generates an accurate current reference used to create all the chip bias currents.

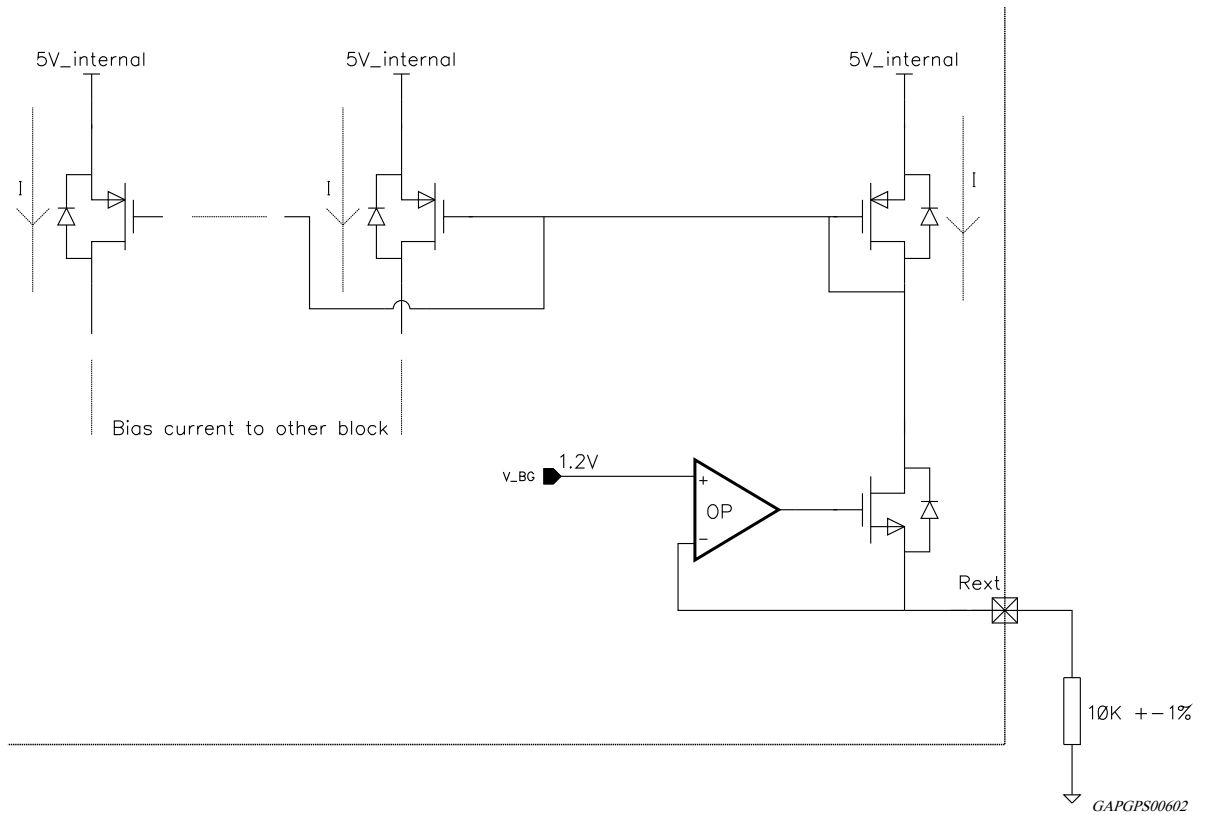
Figure 18. Current generator block diagram

3.3 Power up/down sequences

The figures below show the power-on, power-off and time diagram behaviour of the device.

VDD_{SB} (standby voltage) rises together with battery input, and in standby it is always present if battery is present, no matter the KEY_IN status.

When the KEY_IN signal rises up and remains stable for at least T_{key_deglitch} (see Table 7), the device goes in ON state, meaning that all voltage regulators and functions are active.

Wake-up is an intermediate status between standby and on mode, with current consumption higher than the standby one.

When Key_IN goes low, device goes in OFF mode but standby regulator remains ON.

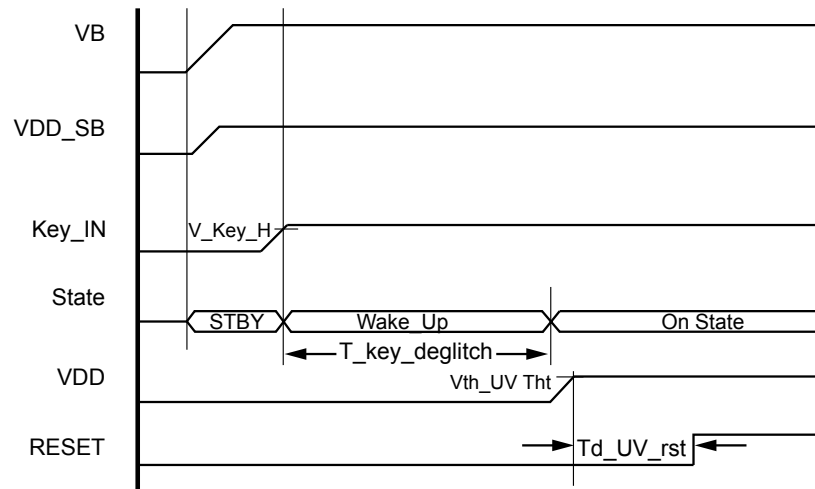
Figure 19. Power-up sequence

GAPGPS00603

Figure 20. Power-down sequence

GAPGPS00604

Reset signal detects a VDD undervoltage longer than TfUV_reset by going to low level. When VDD recovers to normal level Reset signal returns to high level after Power_On_UV_Reset_Delay time (Td_UV_RST). The Reset signal resets all the internal SPI registers to default value.

3.4 SPI

SPI is a standard four wires interface, that communicates with a data word of 24 bits. By means of SPI all the channels can be driven in serial way and diagnosis is sent out. Timing of SPI's operations are reported in [Figure 17](#). The input data (DIN) is read on the rising edge of the SPI's clock (SCLK), in the same way the output data (DOUT) must be read by the Microcontroller on the SCLK's rising edge.

3.4.1 Data in (DIN)

DIN command is used to turn On/Off internal channels which do not have Parallel Input command, and to clear diagnostic latches.

DIN is decoded at the end of the frame if the integrity checks are passed.

Table 25. Data in (DIN) words content

DIN23	DIN22	DIN21	DIN20	DIN19	DIN18	DIN17	DIN16
Mask	L_0	L_1	VRS Diag	VRS Hys0	VRS Hys1	VRS Hys2	0
DIN15	DIN14	DIN13	DIN12	DIN11	DIN10	DIN9	DIN8
INJ1_0	INJ1_1	INJ2_0	INJ2_1	O2H_0	O2H_1	RLY1_0	RLY1_1
DIN7	DIN6	DIN5	DIN4	DIN3	DIN2	DIN1	DIN0
RLY2_0	RLY2_1	RLY3_0	RLY3_1	TACH_0	TACH_1	Clear diag	Parity

Data in structure (MSB first)

- **Mask** bit is used to mask serial command for diagnosis only readings on DOUT:
 0 - Read Diag. All DIN bits are ignored.
 1 - Write. All DIN are transferred into the internal registers.
- **Command** bits are used to control the output drivers: (INJ1-2, O2H, RLY1-2-3, L and TACH) as described in the following table:

Table 26. Data in command bits structure

xxx_0	xxx_1	Description
0	1	Turn-off driver / parallel polarity 0
1	1	Turn-on driver / parallel polarity 1
X	0	No change (the driver will maintain the previous condition)

- **VRS Diag** bit is used active high to enable diagnostic phase of VRS block, the diagnosis can be done only when the phonic wheel is stopped.
- Programmable VRS Hysteresis: VRS hysteresis is programmable in 5 steps according to [Table 27](#).
- **Clear Diag**, when set to 1 generates a request to clear those diagnostic flags which are latched.
- In addition **odd parity bit** (that is the last bit of the frame and includes in its calculation the "Don't care" bits) is used for DIN word check together with falling clock edges count.

Table 27. Data in VRS hysteresis

Hys 0	Hys 1	Hys 2	Description
0	0	0	Auto adaptive hysteresis
1	0	0	Hys VRS = 100 mV
0	1	0	Hys VRS = 200 mV
1	1	0	Hys VRS = 350 mV
0	0	1	Hys VRS = 650 mV
1	0	1	Hys VRS = 1000 mV
1	1	1	Not Valid (Hys doesn't change)

3.4.2
Data out (DOUT)

Status flags are sampled and sent out through DOUT pin at each R/W SPI operation. The structure of the 24 bit word is described in [Table 28](#). A three bits diagnosis is provided for stepper motor driver, a two bit diagnosis for

other drivers. VRS diagnosis is coded as '0' means No Fault, while '1' means Fault. Over temperature warning is coded as '0' means No Fault, while '1' means Fault.

The SPI default value is: all bits set to zero.

Table 28. Data out (DOUT) words content

DOUT23	DOUT22	DOUT21	DOUT20	DOUT19	DOUT18	DOUT17	DOUT16
INJ1 Diag0	INJ1 Diag1	INJ2 Diag0	INJ2 Diag1	O2H Diag0	O2H Diag1	RLY1 Diag0	RLY1 Diag1
DOUT15	DOUT14	DOUT13	DOUT12	DOUT11	DOUT10	DOUT9	DOUT8
RLY2 Diag0	RLY2 Diag1	RLY3 Diag0	RLY3 Diag1	L Diag0	L Diag1	TACH Diag0	TACH Diag1
DOUT7	DOUT6	DOUT5	DOUT4	DOUT3	DOUT2	DOUT1	DOUT0
VRS Diag	Thermal Warning	Brdg1 Diag0	Brdg1 Diag1	Brdg1 Diag2	Brdg2 Diag0	Brdg2 Diag1	Brdg2 Diag2

Data out structure

Table 29. Two bits diagnosis (normal drivers)

Bit 0	Bit 1	Fault
0	0	No Fault
1	0	Short to Ground (OFF)
0	1	Open Load (OFF)
1	1	Overcurrent (ON)

Table 30. Three bits diagnosis (bridge stage)

Bit 0	Bit 1	Bit 2	Fault
0	0	0	No Fault
1	0	0	Short to Ground (OFF)
1	0	1	Short to VBAT (OFF)
0	1	0	Open Load (OFF)
1	1	0	Overcurrent (ON)

3.5 Diagnosis

The device provides a full set of diagnosis; deglitch timings listed below are digital, generated from internal clock and their accuracy is guaranteed by scan patterns and clock measurement.

3.5.1 Voltage regulators thermal warning and shutdown

The 5V linear voltage regulator/tracking regulator is shut down when the thermal shutdown temperature is reached and also the regulator is in current limitation. The shutdown is filtered with Tdcg filter of 30 μ s \pm 25 %. As soon as the over temperature disappears the regulator is switched on again. Over temperature flag without any latch is present via SPI.

3.5.2 Overvoltage shut down

If the VB_off voltage is reached after Tdcg filtering time of 30 μ s \pm 25 % the device enters a safety state where the main outputs are switched-off. Voltage regulators, all low side channels, stepper motor driver and KLINE are switched off and reset is asserted. As soon as the battery goes below VB_off minus VB_off_h the device recovers standard operation.

3.5.3 Undervoltage shut down

If the V_{B_UV} voltage is reached after analog T_{dgc} $1 \mu s \pm 20 \%$ filtering time the device enters a safety state where main outputs are switched-off. Voltage regulators, all low side channels, stepper motor driver and KLINE are switched off. As soon as the battery rises above V_{B_UV} plus the hysteresis the device recovers normal operation.

Figure 21. An example of under and over voltage time diagram

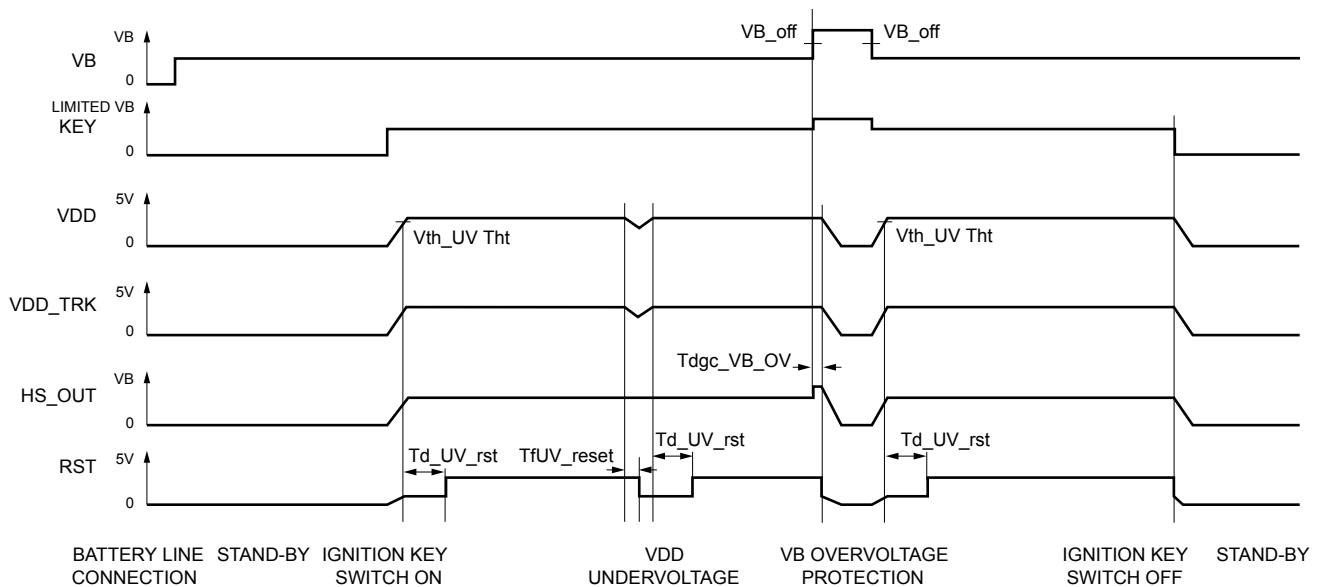

GADG0412171117PS

3.5.4 Low side on/off diagnosis (INJ, RLY's, TACH, O2H)

About low side channels OFF diagnosis, the device issues a masking filter T_{mask} after channel turning off (falling edge of driving command) to avoid false fault detecting due to output transition from low to high. T_{mask} is of $1 \text{ ms} \pm 25 \%$ for all channels except for the relays, for which T_{mask} is $3.5 \text{ ms} \pm 25 \%$. Once masking time has expired a deglitch filter T_{dgc_noise} of $3.6 \mu s \pm 40 \%$ for noise immunity is activated. A fault longer than deglitch time is latched. OFF state diagnostic fault can be overwritten by ON state fault. OFF state fault does not prevent the driver from switching on. The latched fault is cleared on request.

During on-phase if an over current fault occurs the drivers enter in current limitation condition for a digital filtering time T_{dgc} of $20 \mu s \pm 25 \%$, then it is switched OFF and the fault is latched. The channel is turned ON again by input command transition. The latched fault is cleared on request via SPI.

Over current fault has higher priority respect to OFF condition faults.

Figure 22. Low side driver diagnosis time diagram

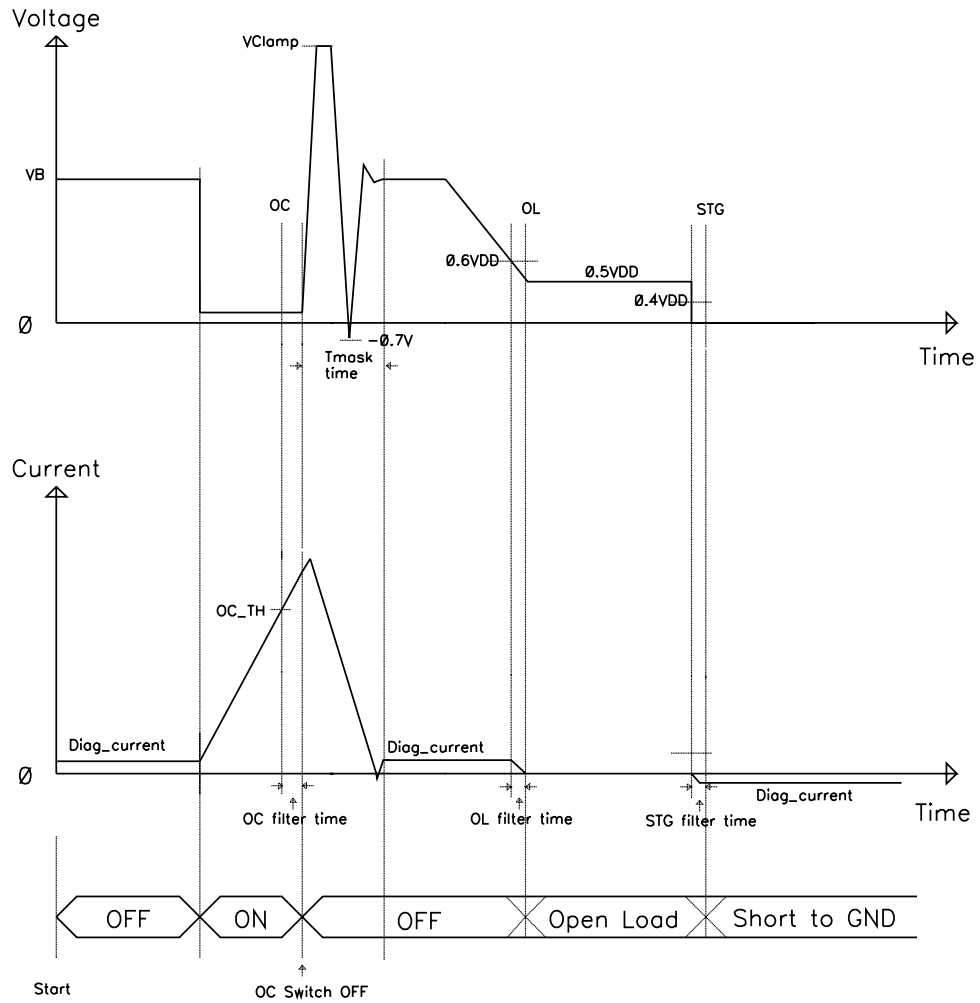

GAPGPS00606

Figure 23. Low side driver diagnosis I-V relationship

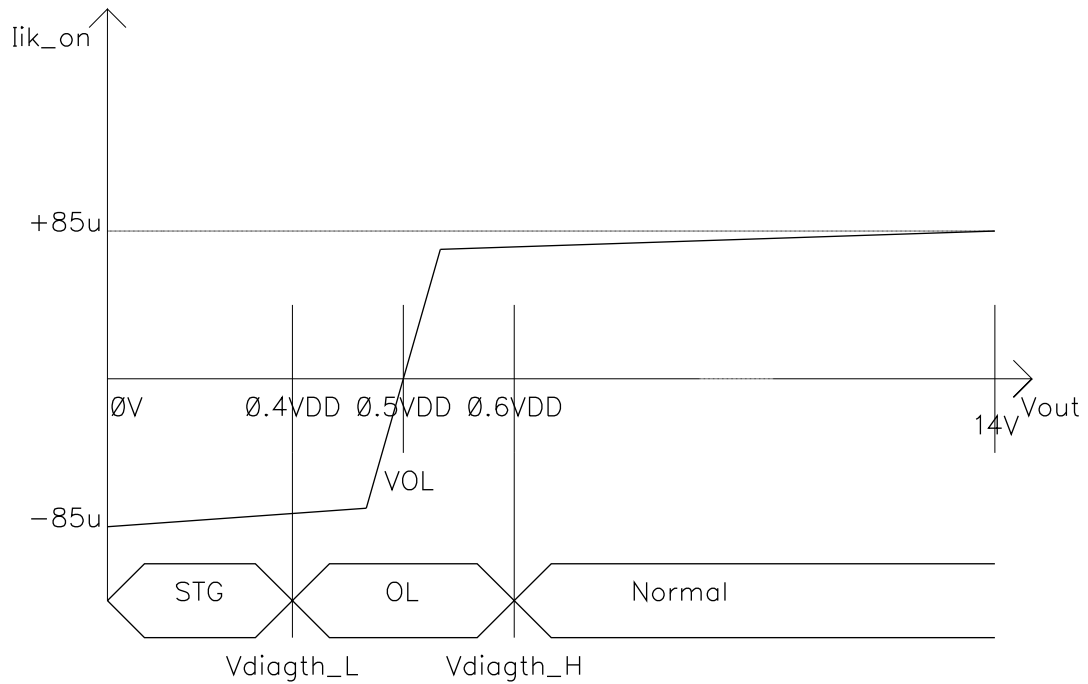

GAPGPS00607

3.5.5 Current limited low side driver on/off diagnosis

In OFF condition diagnosis is the same as Low side, with T_{mask} $3.5\text{ ms} \pm 25\%$ and T_{dgc_noise} $3.6\ \mu s \pm 40\%$, while in ON condition initial Inrush current is masked for T_{mask_rush} of $336\ \mu s \pm 25\%$ then, if an over current fault occurs the drivers enter in current limitation condition for a digital filtering time T_{dgc} of $20\ \mu s \pm 25\%$, then it is switched OFF and the fault is latched. The channel is turned ON again by input command transition. The latched fault is cleared on request via SPI. Over current fault has higher priority with respect to OFF condition faults.

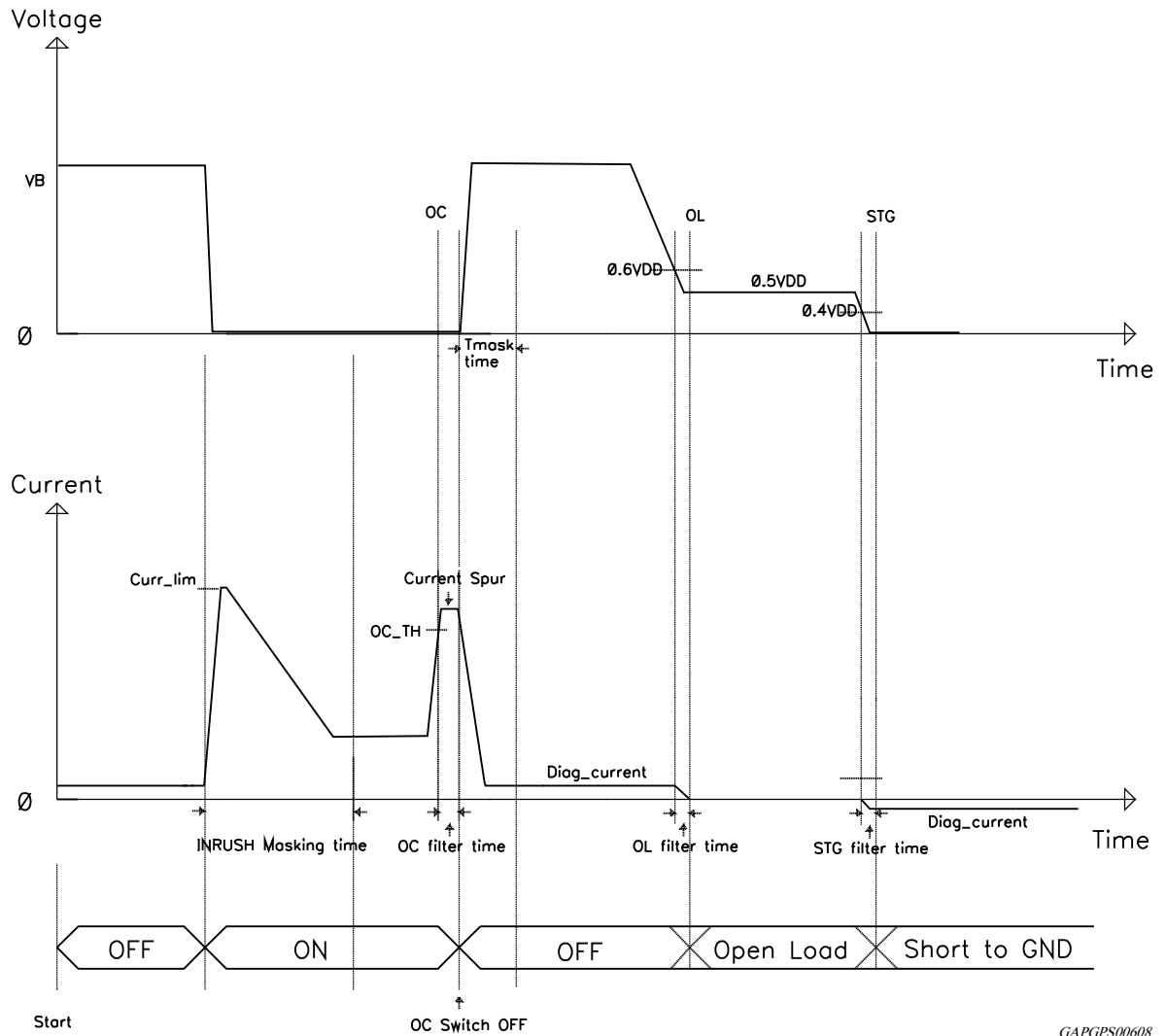
Figure 24. Current limited low side driver diagnosis time diagram

GAPGPS00608

3.5.6 Stepper motor driver OFF diagnosis (EN signal low and output in high impedance state)

In OFF condition Short to GND/Short to V_B or Open Load condition is continuously detected through a deglitch filter of $125 \mu s \pm 25 \%$, after T_{mask} masking time of $1 ms \pm 25 \%$ to filter ON/ OFF transition. To avoid false diagnostic due to motor residual movement, the stepper has to be disabled at least 40 ms after the PWL signal has been disabled. A fault longer than deglitch time is latched. OFF state diagnostic fault can be overwritten by ON state fault. OFF state fault does not prevent the stepper from switching on. The latched fault is cleared on request.

3.5.7 Stepper motor driver ON diagnosis (EN signal high and output driven by input commands)

In ON condition when over current fault is detected and validated after digital filtering time T_{dgc} of $20 \mu s \pm 25 \%$, the bridge is turned OFF and the fault is latched. The bridge is turned ON again by input command EN transition. The latched fault is cleared on request. Over current fault has higher priority with respect to OFF condition faults. Each Bridge has dedicated fault diagnosis detection coded by three bits.

Figure 25. Stepper motor driver diagnosis time diagram

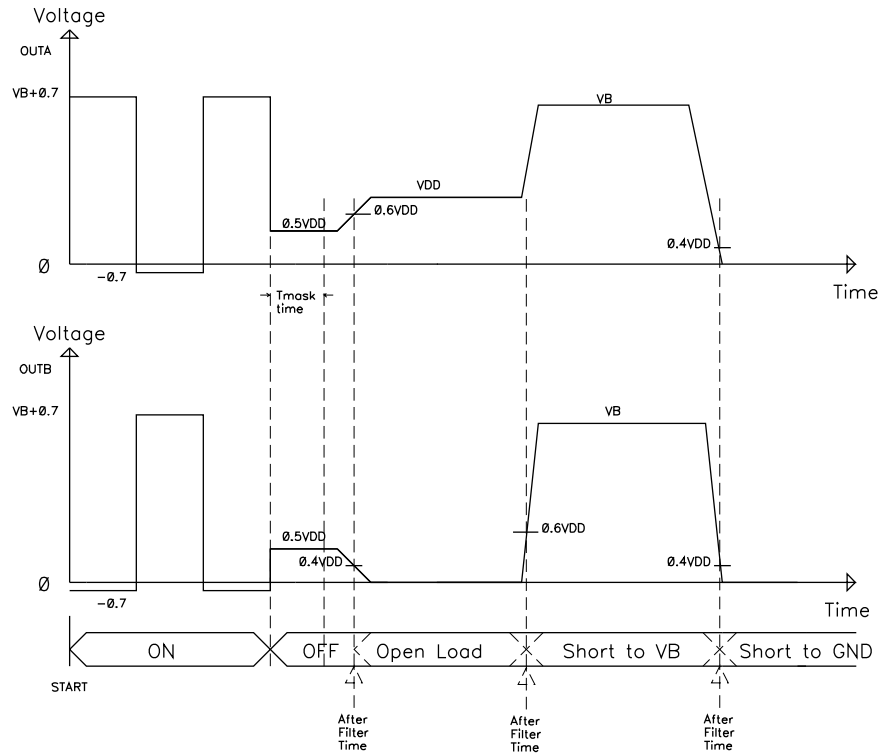

GAPGPS00609

Figure 26. Stepper motor driver diagnosis I-V relationship

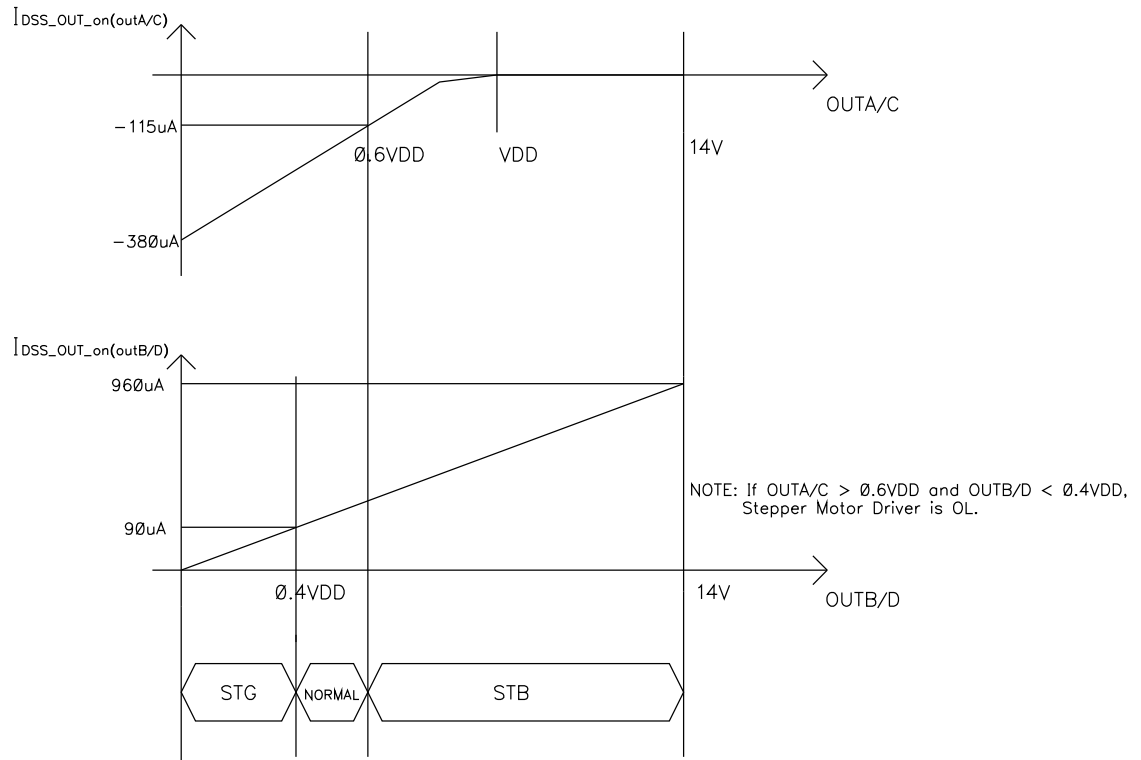

H-Bridge diagnostic I_V plot(TYP)

GAPGPS00610

3.5.8 VRS diagnosis

VRS block enters diagnosis phase on request via SPI and then generates a Fault bit. If the fault exceeds the T_{dgc} filter time of 30 μs ±20 %, it is latched. The latched fault is cleared on request via SPI. The VRS diagnostic can only be activated when the phonic wheel is in stop condition.

Figure 27. VRS diagnosis I-V relationship

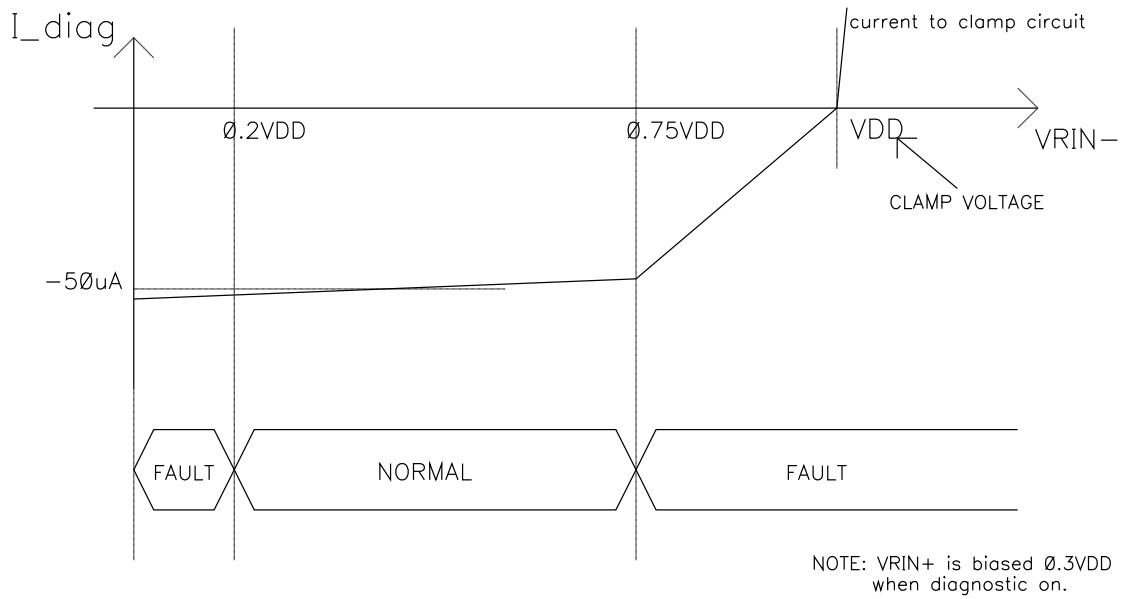

GAPGPS00611

3.6 VRS interface

3.6.1 Function characteristic

The flying wheel interface is an interface between the μP and the flying wheel sensor: it conditions signal coming from magnetic pick-up sensor or hall effect sensor and feeds the digital signal to microcontroller that extracts flying wheel rotational position, angular speed and acceleration.

Figure 28. VRS typical characteristics

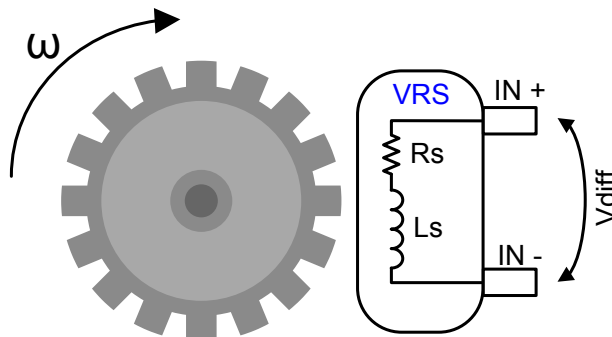

GAPGPS00571

Figure 29. VRS interface structure

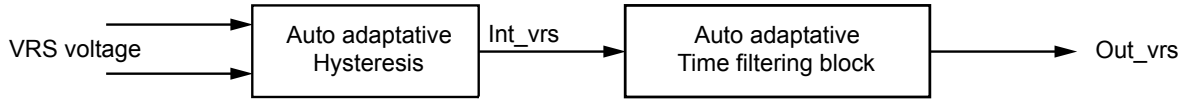

GAPGPS00612

3.6.2 Auto-adaptative hysteresis

Input signals difference is obtained through a full differential amplifier; its output, DV signal, is fed to peak detection circuit and then to A/D converter implemented with 4 voltage comparator (5 levels Pvi). Output of A/D is sent to Logic block (hysteresis selection Table 32) that implements correlation function between Peak voltage and hysteresis value; hysteresis value is used by square filtering circuit which conditions DV signal.

Figure 30. Auto-adaptative hysteresis block diagram

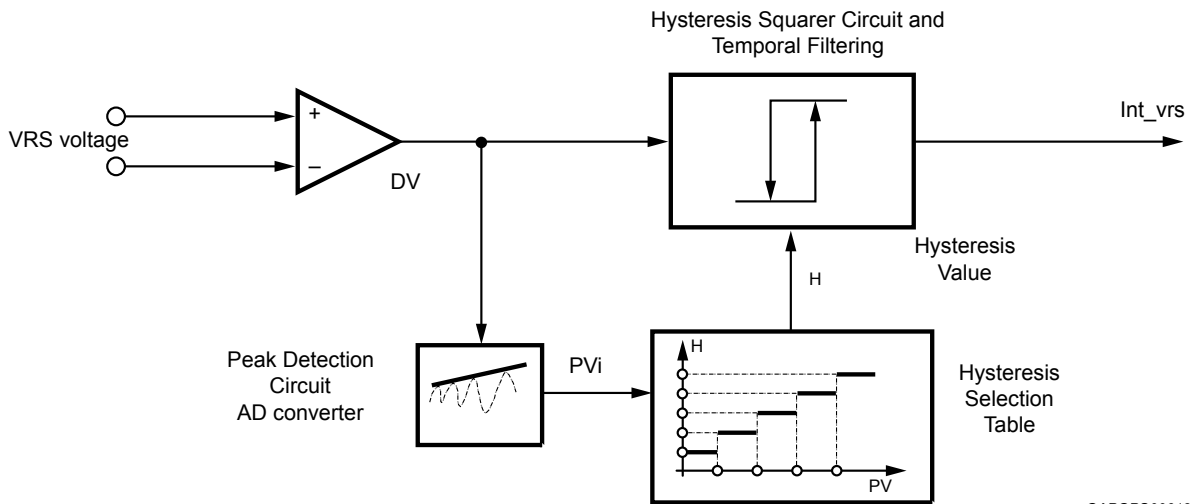

GAPGPS00613

Figure 31. Hysteresis output voltage level

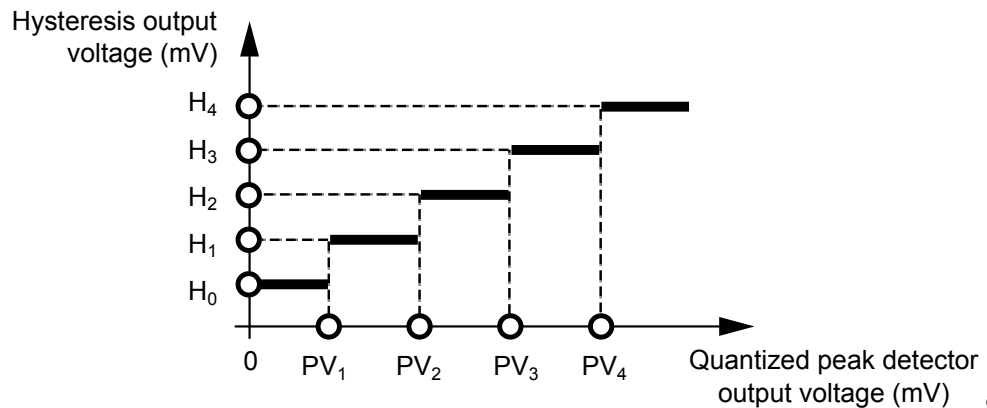

GAPGPS00614

To the previous 5 levels $PV = [0 \ PV1 \ PV2 \ PV3 \ PV4]$ correspond to a set of 5 thresholds:

- $H = [H0 \ H1 \ H2 \ H3 \ H4]$

The advised values for the previous defined vectors are:

- $PV = [0 \ PV1 \ PV2 \ PV3 \ PV4] = [0, 900, 1560, 2230, 2900]$ mV
- $H = [H0 \ H1 \ H2 \ H3 \ H4] = [100, 200, 350, 650, 1000]$ mV

Table 31. Peak voltage detector precision

Pick voltage [PV]	Value			Unit
	Min.	Typ.	Max.	
PV1	850	900	950	mV
PV2	1452	1560	1638	mV
PV3	2118	2230	2341	mV
PV4	2755	2900	3045	mV

Table 32. Hysteresis threshold precision

Pick voltage [PV]	Value			Unit
	Min.	Typ.	Max.	
H0	70	100	130	mV
HV1	140	200	220	mV
HV2	250	347	390	mV
HV3	490	644	720	mV
HV4	730	1000	1120	mV

Note: Hysteresis voltages are achieved by injecting an hysteresis bias current on $V_{RIN\pm}$ external resistors (typ. 10 k Ω each, see [Figure 38](#)). The resulting HV voltage is $HV = I_{hys} * R_{typ}$. Changing the value of R the hysteresis value would change in a linear mode.

Figure 32. Input-output behaviour of VRS interface

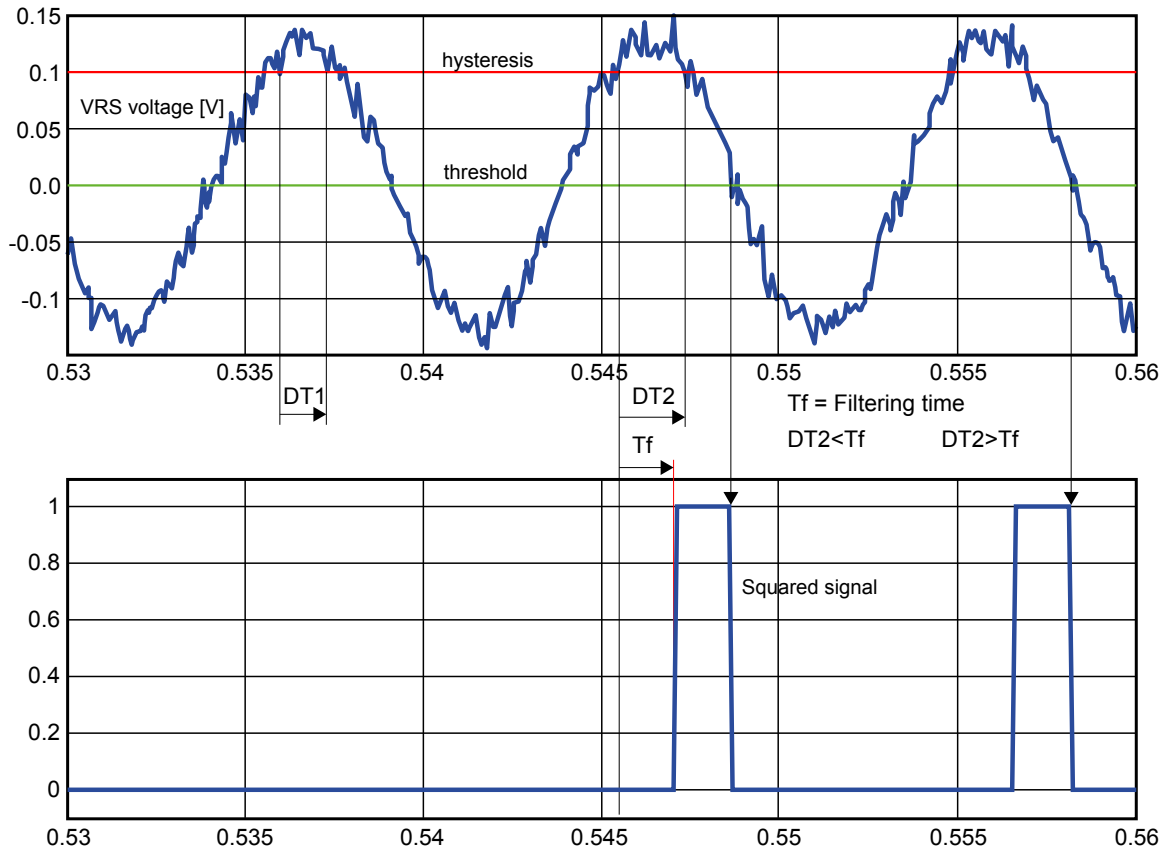

GAPGPS00615

3.6.3 Auto-adaptative time filter

This characteristic is useful to set the best internal filter time as function of the input signal frequency.

The Tfilter time depends on the previous period duration Tn according to the following formula:

$$T_{\text{filter}(n+1)} = 1/32 * T_n \text{ if } T_n > T_{\text{filter}(n)}$$

The filtering time purpose is to filter very short spikes.

The digital filtering time is applied to internal squared signal (int_vrs), obtained by voltage comparators.

The output of time filtering block is out_vrs signal.

The filtering time Tfilter is applied to int_vrs signal in two different ways:

- Rising edge: if int_vrs high level lasts less than Tfilter, out_vrs is not set to high level.
- In absence of any spikes during input signal rising edge out_vrs signal is expected with a delay of Tfilter time.
- Falling edge: the falling edge of int_vrs is not delayed through time filtering block: after falling edge for a time Tfilter any other transition on int_vrs signal is ignored

The initial value (Default) and maximum for Tfilter must be considered at RPM_min = 20 e.g. Tmax filter = 180 μs. The minimum available value is Tmin filter = 2.8 μs.

Figure 33. Auto-adaptative time filter behaviour 1

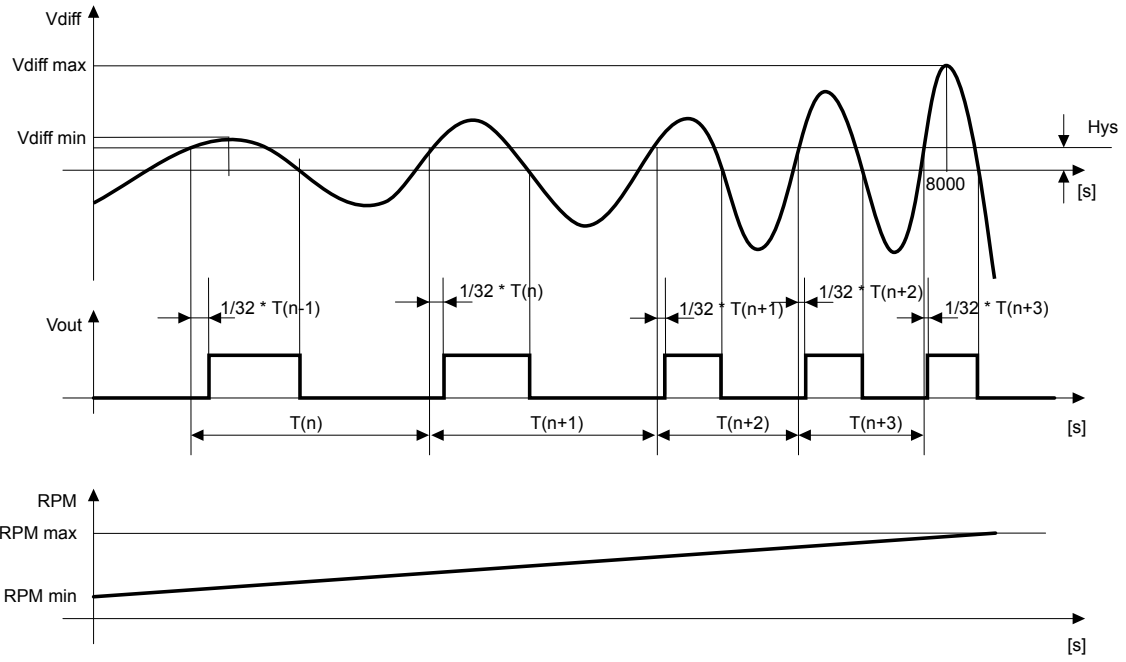

GAPGPS00616

Figure 34. Auto-adaptative time filter behaviour 2

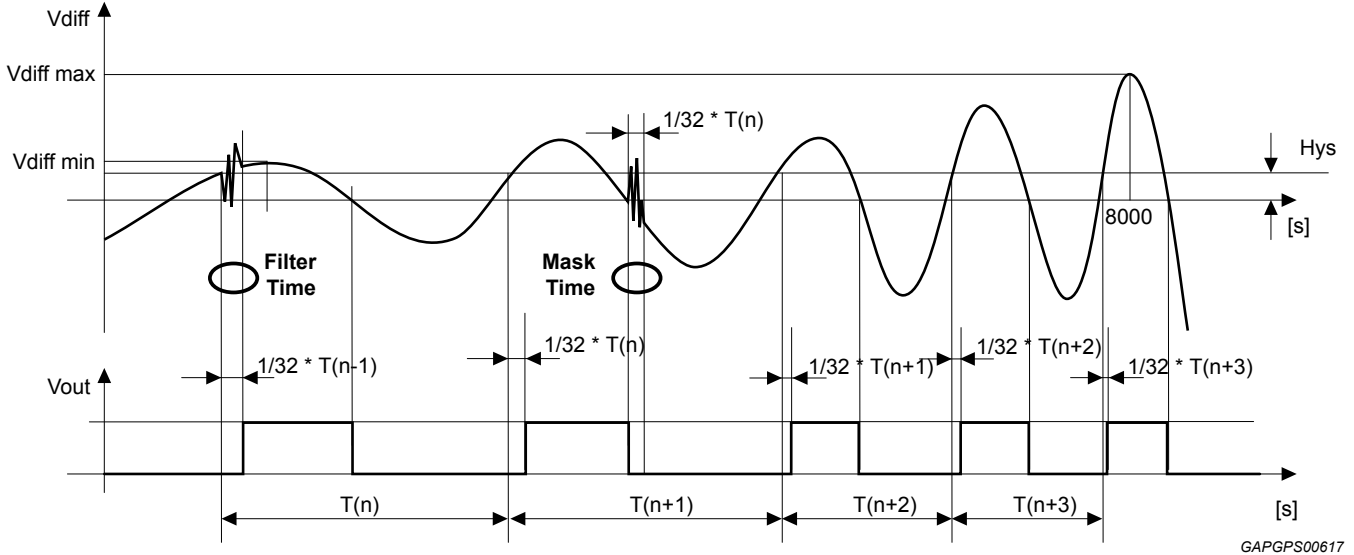

GAPGPS00617

4 Low side drivers

Low side drivers have a voltage slew rate control during switch-on/off phase to reduce emissions. The slew-rate control is achieved controlling the gate charging current and the behavior is described in [Figure 35](#) and [Figure 36](#).

Figure 35. Low side drivers slew rate implementation

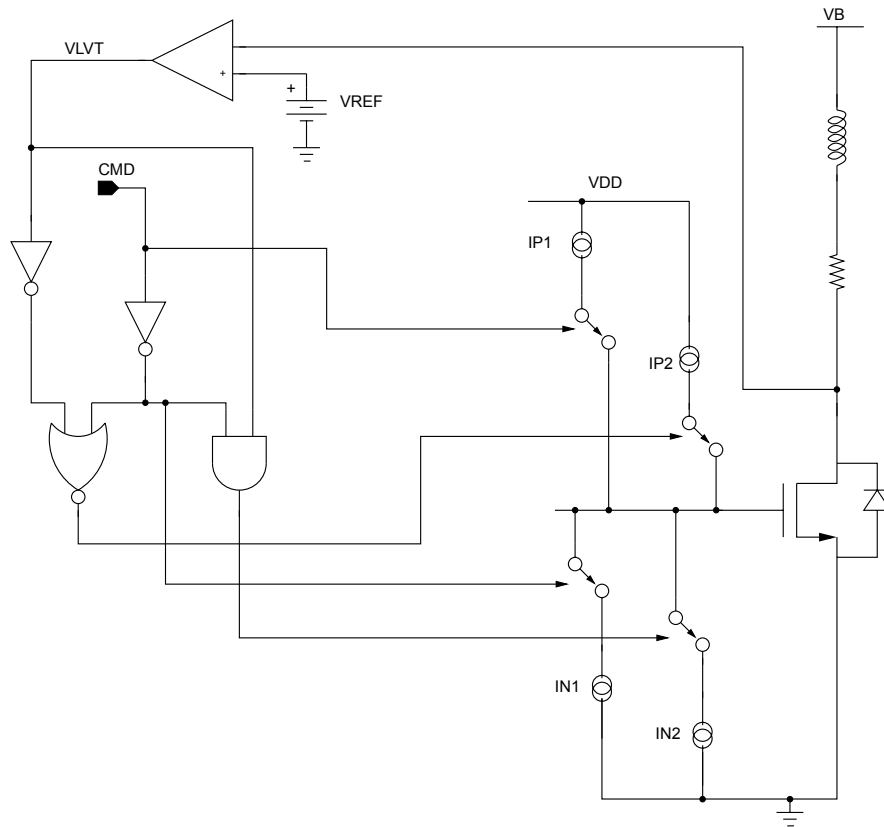

GAPGPS00618

Figure 36. Low side drivers slew rate

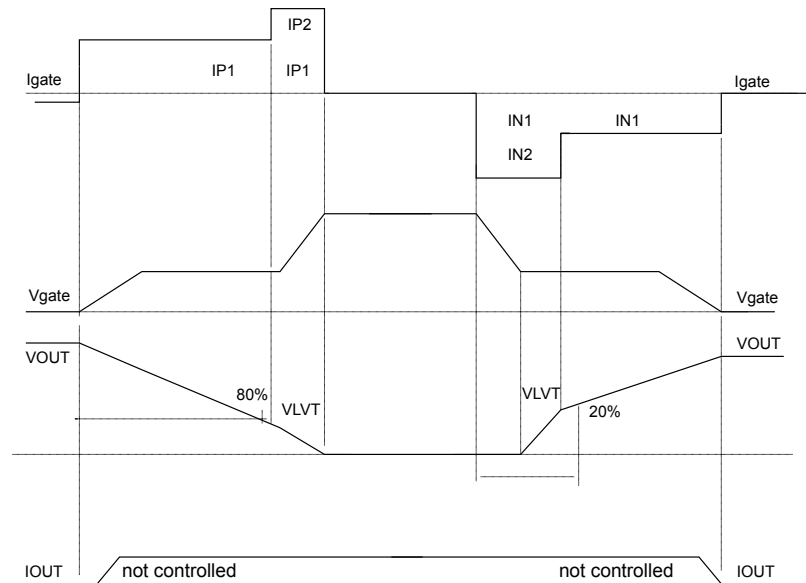

GAPGPS00619

At switch-on command the charging current is provided by current generator IP1 and is kept constant until the output voltage is decreased of roughly 80% of typical battery level. At this point the low side transistor is on and VLVT signal is set to logic 1 to connect IP2 current generator in parallel with IP1, completing the gate charge curve and providing maximum gate drive.

When the power transistor is switched-off the gate is discharged quickly using both IN1 and IN2 currents; as soon as the output voltage reaches roughly 20 % of the nominal battery voltage only IN1 is kept connected to complete the gate discharging.

In Table 33 the values for IPx and INx current generators are reported for each low side.

As an example Figure 37 shows the resulting slew rate, in typical conditions, of O2H low side driver.

Table 33. Values for IPx and INx current generators for each low side

Low side	IP1	IP2	IN1	IN2	Unit
O2H	243	81	253	337	μA
INJ	174	23	180	124	μA
RLY's	78	0	80	120	μA
L	78	0	62	119	μA
TACH	22	0	21	25	μA

Figure 37. O2H low side driver slew rate

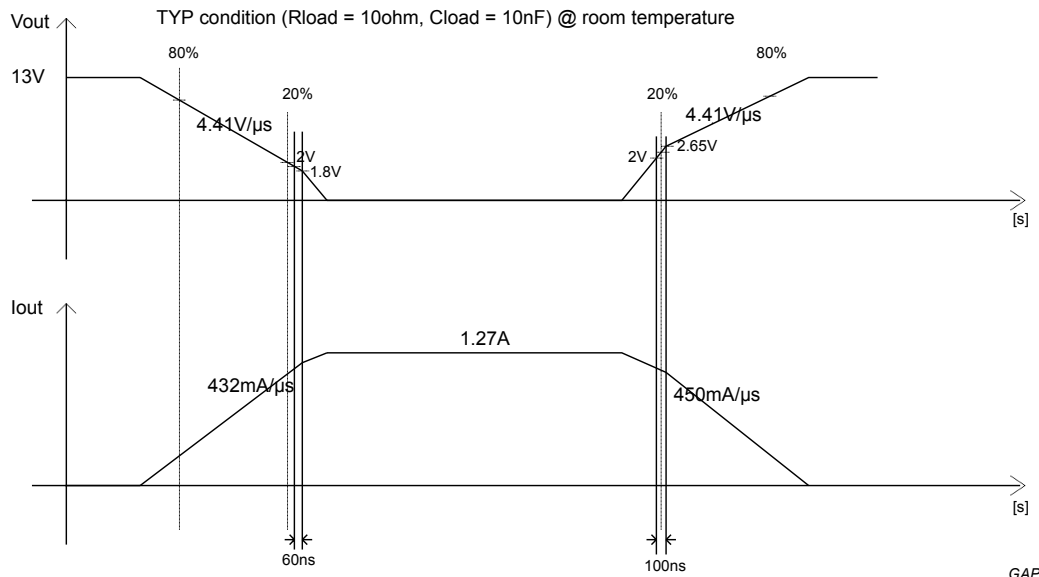

GAPGPS00620

5 Application circuit

Figure 38. Application circuit

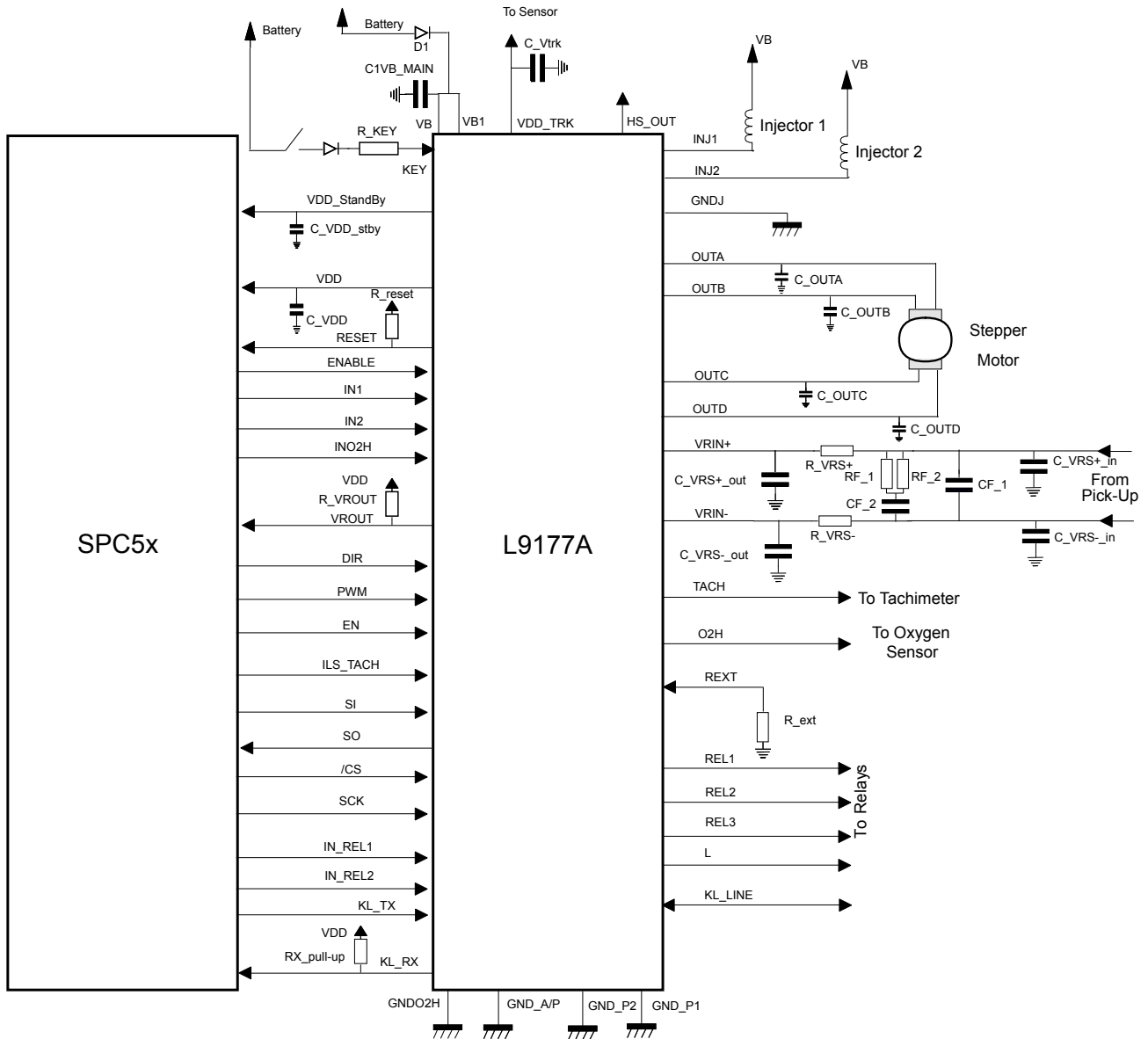

GAPG1303150713PS

5.1 Bill of material

Table 34. Bill of material

Block	Component	Name	Usage	Min	Typ	Max	Unit
Supply	Capacitor	C1VB_MAIN	Bulk capacitor		220		μF
	Diode	D1	Reverse polarization protection diode				
Key	Resistor	R_Key	Current limiting resistor		20		kΩ

Block	Component	Name	Usage	Min	Typ	Max	Unit
Rext	Resistor	R_ext	Pull-up resistor		10 (1%)		kΩ
Reset	Resistor	R_reset	Pull-up resistor		1		kΩ
VDD	Capacitor	C_VDD value	Output capacitor (Ceramic or Tantalum)	4.7		60	μF
		C_VDD ESR				1.5	Ω
VDD_trk	Capacitor	C_Vtrk value	Output capacitor	2.2		100	μF
		C_Vtrk ESR		10		100	mΩ
Vdd_sby	Capacitor	C_VDD_stby value	Output capacitor	1		10	μF
		C_VDD_stby ESR				200	mΩ
VRS	Capacitor	C_VRS+_in	Filter Capacitor			100	pF
VRS	Capacitor	C_VRS-_in	Filter Capacitor			100	pF
VRS	Capacitor	C_VRS+_out	Filter Capacitor			470	pF
VRS	Capacitor	C_VRS-_out	Filter Capacitor			470	pF
VRS	Resistor	R_VRS+	Current limiting resistor			10	kΩ
VRS	Resistor	R_VRS-	Current limiting resistor			10	kΩ
VRS	Capacitor	CF_1	Filter Capacitor			470	pF
VRS	Capacitor	CF_2	Filter Capacitor			100	nF
VRS	Resistor	RF_1	Filter resistor			33	kΩ
VRS	Resistor	RF_2	Filter resistor			33	kΩ
VRS	Resistor	R_VROUT	Pull-up resistor		10		kΩ
K-Line	Resistor	RX_pull-up	Pull-up resistor			2	kΩ
Stepper	Capacitor	C_OUTA	EMI filter capacitor			10	nF
Stepper	Capacitor	C_OUTB	EMI filter capacitor			10	nF
Stepper	Capacitor	C_OUTC	EMI filter capacitor			10	nF
Stepper	Capacitor	C_OUTD	EMI filter capacitor			10	nF

Table 35. TQFP64 (10x10x1 mm exp. pad down) package mechanical data

Ref	Min.	Typ.	Max.	Note (see # in Notes below)
Θ	0°	3.5°	7°	-
Θ1	0°	-	-	-
Θ2	11°	12°	13°	-
Θ3	11°	12°	13°	-
A	-	-	1.2	15
A1	0.05	-	0.15	12
A2	0.95	1	1.05	15
b	0.17	0.22	0.27	9, 11
b1	0.17	0.2	0.23	11
c	0.09	-	0.2	11
c1	0.09	-	0.16	11
D	-	12.00 BSC	-	4
D1	-	10.00 BSC	-	5, 2
D2	See VARIATIONS			13
D3	See VARIATIONS			14
e	-	0.50 BSC	-	-
E	-	12.00 BSC	-	4
E1(*)	-	10.00 BSC	-	5, 2
E2	See VARIATIONS			13
E3	See VARIATIONS			14
L	0.45	0.6	0.75	-
L1	-	1.00 REF	-	-
N	-	64	-	16
R1	0.08	-	-	-
R2	0.08	-	0.2	-
S	0.2	-	-	-
Tolerance of form and position				
aaa	-	0.2	-	1, 7
bbb	-	0.2	-	
ccc	-	0.08	-	
ddd	-	0.08	-	
VARIATIONS				
Pad option 4.3 x 4.3 (T3)				
D2	-	-	4.65	13, 14
E2	-	-	4.65	
D3	2.90	-	-	
E3	2.90	-	-	
Pad option 4.5 x 4.5 (T1-T3)				

Ref	Min.	Typ.	Max.	Note (see # in Notes below)
D2	-	-	4.98	13, 14
E2	-	-	4.98	
D3	3.29	-	-	
E3	3.29	-	-	
Pad option 6.0 x 6.0 (T3)				
D2	-	-	6.40	13, 14
E2	-	-	6.40	
D3	4.80	-	-	
E3	4.80	-	-	
Pad option 7.5 x 7.5 (T1)				
D2	-	-	7.60	13, 14
E2	-	-	7.60	
D3	7.30	-	-	
E3	7.30	-	-	

Notes

1. Dimensioning and tolerancing schemes conform to ASME Y14.5M-1994.
2. The Top package body size may be smaller than the bottom package size up to 0.15 mm.
3. Datum A-B and D to be determined at datum plane H.
4. To be determined at seating datum plane C.
5. Dimensions D1 and E1 do not include mold flash or protrusions. Allowable mold flash or protrusions is "0.25 mm" per side. D1 and E1 are Maximum plastic body size dimensions including mold mismatch.
6. Details of pin 1 identifier are optional but must be located within the zone indicated.
7. All Dimensions are in millimeters.
8. No intrusion allowed inwards the leads.
9. Dimension "b" does not include dambar protrusion. Allowable dambar protrusion shall not cause the lead width to exceed the maximum "b" dimension by more than 0.08 mm. Dambar cannot be located on the lower radius or the foot. Minimum space between protrusion and an adjacent lead is 0.07 mm for 0.4 mm and 0.5 mm pitch packages.
10. Exact shape of each corner is optional.
11. These dimensions apply to the flat section of the lead between 0.10 mm and 0.25 mm from the lead tip.
12. A1 is defined as the distance from the seating plane to the lowest point on the package body.
13. Dimensions D2 and E2 show the maximum exposed metal area on the package surface where the exposed pad is located (if present). It includes all metal protrusions from exposed pad itself.
14. Dimensions D3 and E3 show the minimum solderable area, defined as the portion of exposed pad which is guaranteed to be free from resin flashes/bleeds, bordered by internal edge of inner groove.
15. The optional exposed pad is generally coincident with the top or bottom side of the package and not allowed to protrude beyond that surface.
16. "N" is the number of terminal positions for the specified body size.

Revision history

Table 36. Document revision history

Date	Revision	Changes
20-Sep-2017	1	Initial release.
29-Sep-2017	2	<p>Updated Table 1. Pin function pin 27 column "Class" from SIGNAL to PWR;</p> <p>Updated Section 2.1.1 Supply voltage;</p> <p>Changed titles: Section 3.5.6 Stepper motor driver OFF diagnosis (EN signal low and output in high impedance state) and Section 3.5.7 Stepper motor driver ON diagnosis (EN signal high and output driven by input commands);</p> <p>Updated "Notes" in the Table 4. ESD protection;</p> <p>Updated unit of "T_key_deglitch" parameter" in Table 7. Key electrical characteristics and "R_pull" in Table 8. Digital pins characteristics.</p>
05-Dec-2017	3	<p>Corrected typos in the titles of the sections: Section 3.5.6 Stepper motor driver OFF diagnosis (EN signal low and output in high impedance state) and Section 3.5.7 Stepper motor driver ON diagnosis (EN signal high and output driven by input commands).</p> <p>Updated Table 1. Pin function.</p> <p>Substituted in the datasheet (texts, tables and drawings) "Vdd" with "VDD".</p> <p>Updated: Figure 5. 5 V main regulator block diagram; Section 2.5.9 High side switch; Figure 10. Low-side driver block diagram; Figure 16. SO loading for disable time measurement; Figure 17. SPI timing diagram; Section 3.4.1 Data in (DIN); Section 3.4.2 Data out (DOUT); Section 3.5.3 Undervoltage shut down; Section 5.1 Bill of material.</p>
26-Nov-2018	4	<p>Updated:</p> <p>Section Description; Section 2.1 Operating range; Section 2.2 Absolute maximum ratings; Table 8. Digital pins characteristics; Figure 5. 5 V main regulator block diagram; Figure 3. Input threshold; Table 17. Current limited LSD driver characteristics; Section 3.5.5 Current limited low side driver on/off diagnosis; Figure 17. SPI timing diagram; Figure 19. Power-up sequence; Figure 20. Power-down sequence; Section 3.4.1 Data in (DIN); Figure 21. An example of under and over voltage time diagram; Section 3.5.8 VRS diagnosis; Figure 38. Application circuit; Table 34. Bill of material.</p> <p>Changed in all document "LAMP" pin in "L" (Current limited LSD). Updated Section 2.5 Electrical characteristics.</p>

Contents

1	Block diagram and pin description	3
1.1	Block diagram	3
1.2	Pin description	4
2	Electrical specifications	7
2.1	Operating range	7
2.1.1	Supply voltage	7
2.2	Absolute maximum ratings	7
2.3	Latch-up test	9
2.4	Temperature ranges and thermal data	9
2.5	Electrical characteristics	9
2.5.1	Supply	9
2.5.2	Key	9
2.5.3	Digital pins	10
2.5.4	Digital output pins	10
2.5.5	5 V voltage regulator	11
2.5.6	Reset	12
2.5.7	5 V tracking voltage regulator	12
2.5.8	Standby regulator	13
2.5.9	High side switch	14
2.5.10	Injector driver	15
2.5.11	Relay drivers	16
2.5.12	Current limited low side driver (LSD)	17
2.5.13	Tachometer driver	18
2.5.14	Stepper motor driver	18
2.5.15	O2 sensor heater driver	20
2.5.16	Variable reluctance sensor interface	21
2.5.17	K-line	22
2.5.18	SPI interface	23
3	Functional description	25
3.1	Chip working conditions	25

3.2	Chip bias current generation	25
3.3	Power up/down sequences	26
3.4	SPI	27
3.4.1	Data in (DIN)	27
3.4.2	Data out	28
3.5	Diagnosis	29
3.5.1	Voltage regulators thermal warning and shutdown	29
3.5.2	Overvoltage shut down	29
3.5.3	Undervoltage shut down	30
3.5.4	Low side on/off diagnosis (INJ, RLY's, TACH, O2H)	30
3.5.5	Current limited low side driver on/off diagnosis	32
3.5.6	Stepper motor driver OFF diagnosis (EN signal low and output in high impedance state) ..	33
3.5.7	Stepper motor driver ON diagnosis (EN signal high and output driven by input commands) .	33
3.5.8	VRS diagnosis	34
3.6	VRS interface	35
3.6.1	Function characteristic	35
3.6.2	Auto-adaptative hysteresis	36
3.6.3	Auto-adaptative time filter	38
4	Low side drivers	40
5	Application circuit	43
5.1	Bill of material	43
6	Package information	45
6.1	TQFP64 (10x10x1 mm exp. pad down) package information	45
	Revision history	48

List of tables

Table 1.	Pin function	4
Table 2.	Operating conditions	7
Table 3.	Absolute maximum ratings	7
Table 4.	ESD protection	8
Table 5.	Temperature ranges and thermal data	9
Table 6.	Supply electrical characteristics	9
Table 7.	Key electrical characteristics	10
Table 8.	Digital pins characteristics	10
Table 9.	Digital output pins characteristics	11
Table 10.	VDD output electrical characteristics	11
Table 11.	Reset function electrical characteristics	12
Table 12.	VDD_TRK output electrical characteristics	13
Table 13.	VDD_SB output electrical characteristics	13
Table 14.	HS_OUT output electrical characteristics	14
Table 15.	Injector driver electrical characteristic	15
Table 16.	Relay driver characteristics	17
Table 17.	Current limited LSD driver characteristics	17
Table 18.	Tachometer driver electrical characteristics	18
Table 19.	Stepper motor driver electrical characteristics	18
Table 20.	O2 sensor heater driver characteristics	20
Table 21.	Variable reluctance sensor interface electrical characteristics	21
Table 22.	K-Line interface electrical characteristics	22
Table 23.	SPI characteristics and timings	23
Table 24.	A outputs working conditions	25
Table 25.	Data in (DIN) words content	28
Table 26.	Data in command bits structure	28
Table 27.	Data in VRS hysteresis	28
Table 28.	Data out (DOUT) words content	29
Table 29.	Two bits diagnosis (normal drivers)	29
Table 30.	Three bits diagnosis (bridge stage)	29
Table 31.	Peak voltage detector precision	37
Table 32.	Hysteresis threshold precision	37
Table 33.	Values for IPx and INx current generators for each low side	41
Table 34.	Bill of material	43
Table 35.	TQFP64 (10x10x1 mm exp. pad down) package mechanical data	46
Table 36.	Document revision history	48

List of figures

Figure 1.	Block diagram	3
Figure 2.	Pin connection (top view)	4
Figure 3.	Input threshold	10
Figure 4.	Key block diagram	10
Figure 5.	5 V main regulator block diagram	12
Figure 6.	Reset	12
Figure 7.	5 V tracking regulator block diagram	13
Figure 8.	5 V standby regulator block diagram	14
Figure 9.	High-side driver block diagram	15
Figure 10.	Low-side driver block diagram	16
Figure 11.	Low-side timing diagram (injectors, relays, current limited LSD, tach, O2H)	16
Figure 12.	Stepper motor driver block diagram	19
Figure 13.	Stepper motor operations	20
Figure 14.	VRS block diagram	22
Figure 15.	K-line block diagram	23
Figure 16.	SO loading for disable time measurement	24
Figure 17.	SPI timing diagram	24
Figure 18.	Current generator block diagram	26
Figure 19.	Power-up sequence	27
Figure 20.	Power-down sequence	27
Figure 21.	An example of under and over voltage time diagram	30
Figure 22.	Low side driver diagnosis time diagram	31
Figure 23.	Low side driver diagnosis I-V relationship	32
Figure 24.	Current limited low side driver diagnosis time diagram	33
Figure 25.	Stepper motor driver diagnosis time diagram	34
Figure 26.	Stepper motor driver diagnosis I-V relationship	34
Figure 27.	VRS diagnosis I-V relationship	35
Figure 28.	VRS typical characteristics	35
Figure 29.	VRS interface structure	36
Figure 30.	Auto-adaptive hysteresis block diagram	36
Figure 31.	Hysteresis output voltage level	36
Figure 32.	Input-output behaviour of VRS interface	38
Figure 33.	Auto-adaptative time filter behaviour 1	39
Figure 34.	Auto-adaptative time filter behaviour 2	39
Figure 35.	Low side drivers slew rate implementation	40
Figure 36.	Low side drivers slew rate	41
Figure 37.	O2H low side driver slew rate	42
Figure 38.	Application circuit	43
Figure 39.	TQFP64 (10x10x1 mm exp. pad down) package outline	45

IMPORTANT NOTICE – PLEASE READ CAREFULLY

STMicroelectronics NV and its subsidiaries (“ST”) reserve the right to make changes, corrections, enhancements, modifications, and improvements to ST products and/or to this document at any time without notice. Purchasers should obtain the latest relevant information on ST products before placing orders. ST products are sold pursuant to ST’s terms and conditions of sale in place at the time of order acknowledgement.

Purchasers are solely responsible for the choice, selection, and use of ST products and ST assumes no liability for application assistance or the design of Purchasers’ products.

No license, express or implied, to any intellectual property right is granted by ST herein.

Resale of ST products with provisions different from the information set forth herein shall void any warranty granted by ST for such product.



ST and the ST logo are trademarks of ST. All other product or service names are the property of their respective owners.

Information in this document supersedes and replaces information previously supplied in any prior versions of this document.





© 2018 STMicroelectronics – All rights reserved

Looking for pricing, stock, or lifecycle information?

Click below to explore more details on WIN SOURCE:

-  [View L9177ATR on WIN SOURCE](#)
-  [STMicroelectronics Information](#)

Optimize Your Supply Chain with WIN SOURCE Solutions

-  Global Sourcing Solution
-  Obsolete Management
-  Cost Control Management
-  Shortage Management
-  Alternative Solution
-  Excess Inventory Management