

MPC8245 Integrated Processor Hardware Specifications

The MPC8245 combines a PowerPC™ MPC603e processor core built on Power Architecture™ technology with a PCI bridge so that system designers can rapidly design systems using peripherals designed for PCI and the other standard interfaces. Also, a high-performance memory controller supports various types of ROM and SDRAM. The MPC8245 is the second of a family of products that provide system-level support for industry-standard interfaces with an MPC603e processor core.

This hardware specification describes pertinent electrical and physical characteristics of the MPC8245. For functional characteristics of the processor, refer to the *MPC8245 Integrated Processor Reference Manual* (MPC8245UM).

For published errata or updates to this document, visit the website listed on the back cover of the document.

1 Overview

The MPC8245 integrated processor is composed of a peripheral logic block and a 32-bit superscalar MPC603e core, as shown in [Figure 1](#).

Contents

1. Overview	1
2. Features	3
3. General Parameters	5
4. Electrical and Thermal Characteristics	5
5. Package Description	31
6. PLL Configurations	39
7. System Design	44
8. Document Revision History	56
9. Ordering Information	62

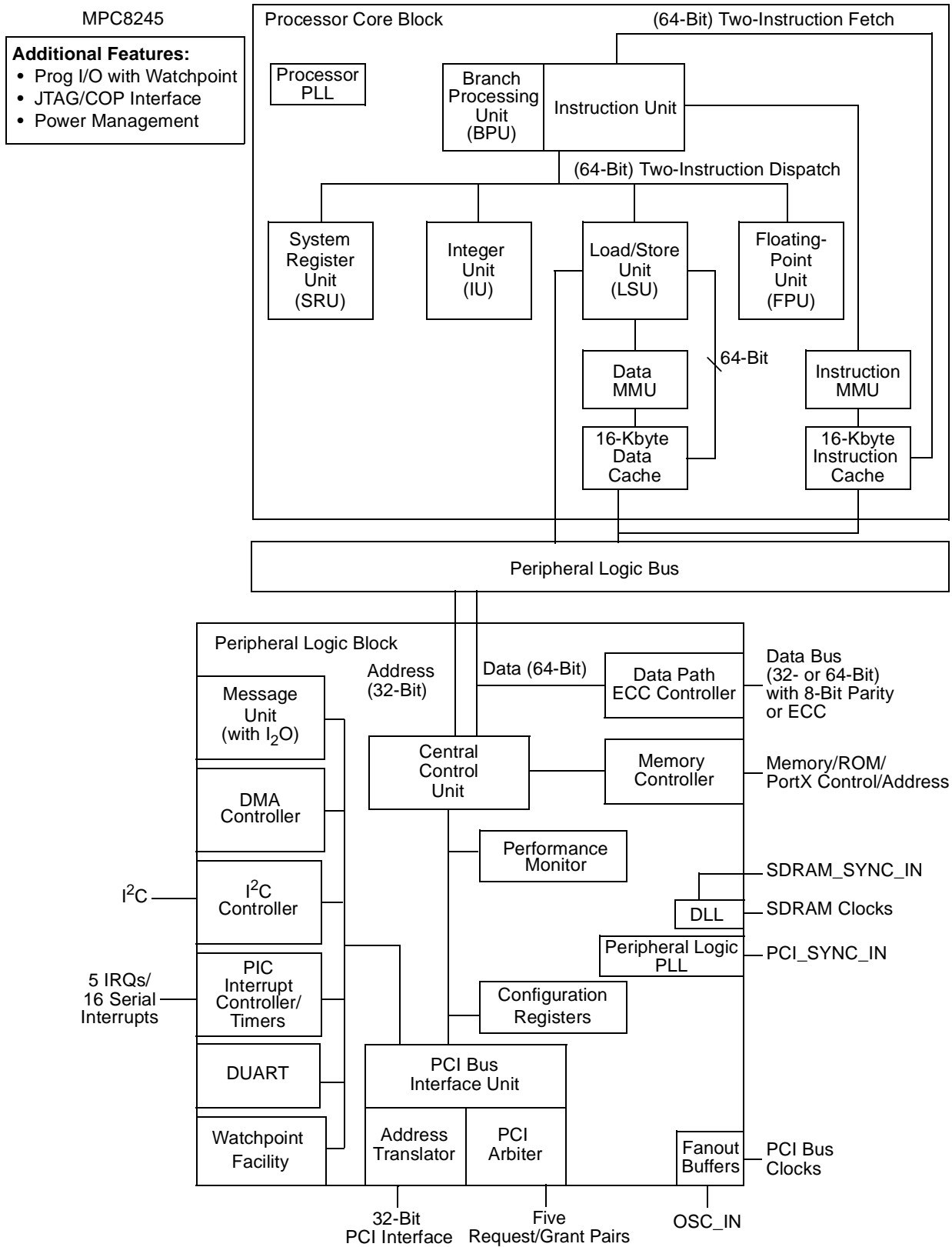

Figure 1. MPC8245 Block Diagram

The peripheral logic integrates a PCI bridge, dual universal asynchronous receiver/transmitter (DUART), memory controller, DMA controller, PIC interrupt controller, a message unit (and I²O interface), and an I²C controller. The processor core is a full-featured, high-performance processor with floating-point support, memory management, a 16-Kbyte instruction cache, a 16-Kbyte data cache, and power management features. The integration reduces the overall packaging requirements and the number of discrete devices required for an embedded system.

An internal peripheral logic bus interfaces the processor core to the peripheral logic. The core can operate at a variety of frequencies, allowing the designer to trade off performance for power consumption. The processor core is clocked from a separate PLL that is referenced to the peripheral logic PLL. This allows the microprocessor and the peripheral logic block to operate at different frequencies while maintaining a synchronous bus interface. The interface uses a 64- or 32-bit data bus (depending on memory data bus width) and a 32-bit address bus along with control signals that enable the interface between the processor and peripheral logic to be optimized for performance. PCI accesses to the MPC8245 memory space are passed to the processor bus for snooping when snoop mode is enabled.

The general-purpose processor core and peripheral logic serve a variety of embedded applications. The MPC8245 can be used as either a PCI host or PCI agent controller.

2 Features

Major features of the MPC8245 are as follows:

- Processor core
 - High-performance, superscalar processor core
 - Integer unit (IU), floating-point unit (FPU) (software enabled or disabled), load/store unit (LSU), system register unit (SRU), and branch processing unit (BPU)
 - 16-Kbyte instruction cache
 - 16-Kbyte data cache
 - Lockable L1 caches—Entire cache or on a per-way basis up to three of four ways
 - Dynamic power management: 60x nap, doze, and sleep modes
- Peripheral logic
 - Peripheral logic bus
 - Various operating frequencies and bus divider ratios
 - 32-bit address bus, 64-bit data bus
 - Full memory coherency
 - Decoupled address and data buses for pipelining of peripheral logic bus accesses
 - Store gathering on peripheral logic bus-to-PCI writes
 - Memory interface
 - Up to 2 Gbytes of SDRAM memory
 - High-bandwidth data bus (32- or 64-bit) to SDRAM
 - Programmable timing supporting SDRAM
 - One to eight banks of 16-, 64-, 128-, 256-, or 512-Mbit memory devices

- Write buffering for PCI and processor accesses
- Normal parity, read-modify-write (RMW), or ECC
- Data-path buffering between memory interface and processor
- Low-voltage TTL logic (LVTTL) interfaces
- 272 Mbytes of base and extended ROM/Flash/PortX space
- Base ROM space for 8-bit data path or same size as the SDRAM data path (32- or 64-bit)
- Extended ROM space for 8-, 16-, 32-bit gathering data path, 32- or 64-bit (wide) data path
- PortX: 8-, 16-, 32-, or 64-bit general-purpose I/O port using ROM controller interface with programmable address strobe timing, data ready input signal ($\overline{\text{DRDY}}$), and 4 chip selects
- 32-bit PCI interface
 - Operates up to 66 MHz
 - PCI 2.2-compatible
 - PCI 5.0-V tolerance
 - Dual address cycle (DAC) for 64-bit PCI addressing (master only)
 - Accesses to PCI memory, I/O, and configuration spaces
 - Selectable big- or little-endian operation
 - Store gathering of processor-to-PCI write and PCI-to-memory write accesses
 - Memory prefetching of PCI read accesses
 - Selectable hardware-enforced coherency
 - PCI bus arbitration unit (five request/grant pairs)
 - PCI agent mode capability
 - Address translation with two inbound and outbound units (ATU)
 - Internal configuration registers accessible from PCI
- Two-channel integrated DMA controller (writes to ROM/PortX not supported)
 - Direct mode or chaining mode (automatic linking of DMA transfers)
 - Scatter gathering—Read or write discontinuous memory
 - 64-byte transfer queue per channel
 - Interrupt on completed segment, chain, and error
 - Local-to-local memory
 - PCI-to-PCI memory
 - Local-to-PCI memory
 - PCI memory-to-local memory
- Message unit
 - Two doorbell registers
 - Two inbound and two outbound messaging registers
 - I₂O message interface
- I²C controller with full master/slave support that accepts broadcast messages

- Programmable interrupt controller (PIC)
 - Five hardware interrupts (IRQs) or 16 serial interrupts
 - Four programmable timers with cascade
- Two (dual) universal asynchronous receiver/transmitters (UARTs)
- Integrated PCI bus and SDRAM clock generation
- Programmable PCI bus and memory interface output drivers
- System-level performance monitor facility
- Debug features
 - Memory attribute and PCI attribute signals
 - Debug address signals
 - \overline{MIV} signal—Marks valid address and data bus cycles on the memory bus
 - Programmable input and output signals with watchpoint capability
 - Error injection/capture on data path
 - IEEE Std 1149.1® (JTAG)/test interface

3 General Parameters

The following list summarizes the general parameters of the MPC8245:

Technology	0.25- μ m CMOS, five-layer metal
Die size	49.2 mm ²
Transistor count	4.5 million
Logic design	Fully-static
Packages	Surface-mount 352 tape ball grid array (TBGA)
Core power supply	1.7 V to 2.1 V DC for 266 and 300 MHz with the condition that the usage is “nominal” \pm 100 mV where “nominal” is 1.8/1.9/2.0 volts. 1.9 V to 2.2 V DC for 333 and 350 MHz with the condition that the usage is “nominal” \pm 100 mV where “nominal” is 2.0/2.1 volts. See Table 2 for details of recommended operating conditions)
I/O power supply	3.0- to 3.6-V DC

4 Electrical and Thermal Characteristics

This section provides the AC and DC electrical specifications and thermal characteristics for the MPC8245.

4.1 DC Electrical Characteristics

This section covers ratings, conditions, and other DC electrical characteristics.

4.1.1 Absolute Maximum Ratings

The tables in this section describe the MPC8245 DC electrical characteristics. [Table 1](#) provides the absolute maximum ratings.

Table 1. Absolute Maximum Ratings

Characteristic ¹	Symbol	Range	Unit
Supply voltage—CPU core and peripheral logic	V _{DD}	-0.3 to 2.25	V
Supply voltage—memory bus drivers	GV _{DD}	-0.3 to 3.6	V
Supply voltage—PCI and standard I/O buffers	OV _{DD}	-0.3 to 3.6	V
Supply voltage—PLLs	AV _{DD} /AV _{DD} ₂	-0.3 to 2.25	V
Supply voltage—PCI reference	LV _{DD}	-0.3 to 5.4	V
Input voltage ²	V _{in}	-0.3 to 3.6	V
Operational die-junction temperature range	T _j	0 to 105 ³	°C
Storage temperature range	T _{stg}	-55 to 150	°C

Notes:

1. Functional and tested operating conditions are given in [Table 2](#). Absolute maximum ratings are stress ratings only, and functional operation at the maximums is not guaranteed. Stress beyond those listed may affect device reliability or cause permanent damage to the device.
2. PCI inputs with LV_{DD} = 5 V ± 5% V DC may be correspondingly stressed at voltages exceeding LV_{DD} + 0.5 V DC.
3. Note that this temperature range does not apply to the 400 MHz parts. For details, refer to the hardware specifications addendum MPC8245ECSO2AD.

4.1.2 Recommended Operating Conditions

[Table 2](#) provides the recommended operating conditions for the MPC8245. Some voltage values do not apply to the 400-MHz parts. For details, refer to the hardware specifications addendum MPC8245ECSO2AD.

Table 2. Recommended Operating Conditions¹

Characteristic	Symbol	Recommended Value	Unit	Notes
Supply voltage	V _{DD}	1.8/1.9/2.0 V ± 100 mV	V	4, 7
		2.0/2.1 V ± 100 mV	V	5, 7
I/O buffer supply for PCI and standard	OV _{DD}	3.3 ± 0.3	V	7
Supply voltages for memory bus drivers	GV _{DD}	3.3 ± 5%	V	9
CPU PLL supply voltage	AV _{DD}	1.8/1.9/2.0 V ±	V	4, 7, 12
		2.0/2.1 V ±	V	5, 7, 12

Table 2. Recommended Operating Conditions¹ (continued)

Characteristic		Symbol	Recommended Value	Unit	Notes
PLL supply voltage—peripheral logic		AV _{DD2}	1.8/1.9/2.0 V ±	V	4, 7, 12
			2.0/2.1 V ±	V	5, 7, 12
PCI reference		LV _{DD}	5.0 ± 5%	V	2, 10, 11
			3.3 ± 0.3	V	3, 10, 11
Input voltage	PCI inputs	V _{in}	0 to 3.6 or 5.75	V	2, 3
	All other inputs		0 to 3.6	V	6
Die-junction temperature		T _j	0 to 105	°C	

Notes:

- These are the recommended and tested operating conditions. Proper device operation outside of these conditions is not guaranteed.
- PCI pins are designed to withstand LV_{DD} + 5% V DC when LV_{DD} is connected to a 5.0-V DC power supply.
- PCI pins are designed to withstand LV_{DD} + 0.5 V DC when LV_{DD} is connected to a 3.3-V DC power supply.
- The voltage supply value of 1.8/1.9/2.0 V ± 100 mV applies to parts marked as having a maximum CPU speed of 266 and 300 MHz. See [Table 7](#). For each chosen nominal value (1.8/1.9/2.0 V) the supply voltage should not exceed ± 100 mV of the nominal value.
- The voltage supply value of 2.0/2.1 V ± 100 mV applies to parts marked as having a maximum CPU speed of 333 and 350 MHz. See [Table 7](#). For each chosen nominal value (2.0/2.1 V) the supply voltage should not exceed ± 100 mV of the nominal value.

Cautions:

- Input voltage (V_{in}) must not be greater than the supply voltage (V_{DD}/AV_{DD}/AV_{DD2}) by more than 2.5 V at all times, including during power-on reset. Input voltage (V_{in}) must not be greater than GV_{DD}/OV_{DD} by more than 0.6 V at all times, including during power-on reset.
- OV_{DD} must not exceed V_{DD}/AV_{DD}/AV_{DD2} by more than 1.8 V at any time, including during power-on reset. This limit may be exceeded for a maximum of 20 ms during power-on reset and power-down sequences.
- V_{DD}/AV_{DD}/AV_{DD2} must not exceed OV_{DD} by more than 0.6 V at any time, including during power-on reset. This limit may be exceeded for a maximum of 20 ms during power-on reset and power-down sequences.
- GV_{DD} must not exceed V_{DD}/AV_{DD}/AV_{DD2} by more than 1.8 V at any time, including during power-on reset. This limit may be exceeded for a maximum of 20 ms during power-on reset and power-down sequences.
- LV_{DD} must not exceed V_{DD}/AV_{DD}/AV_{DD2} by more than 5.4 V at any time, including during power-on reset. This limit may be exceeded for a maximum of 20 ms during power-on reset and power-down sequences.
- LV_{DD} must not exceed OV_{DD} by more than 3.0 V at any time, including during power-on reset. This limit may be exceeded for a maximum of 20 ms during power-on reset and power-down sequences.
- This voltage is the input to the filter discussed in [Section 7.1, "PLL Power Supply Filtering,"](#) and not necessarily the voltage at the AV_{DD} pin, which may be reduced from V_{DD} by the filter.

Figure 2 shows supply voltage sequencing and separation cautions.

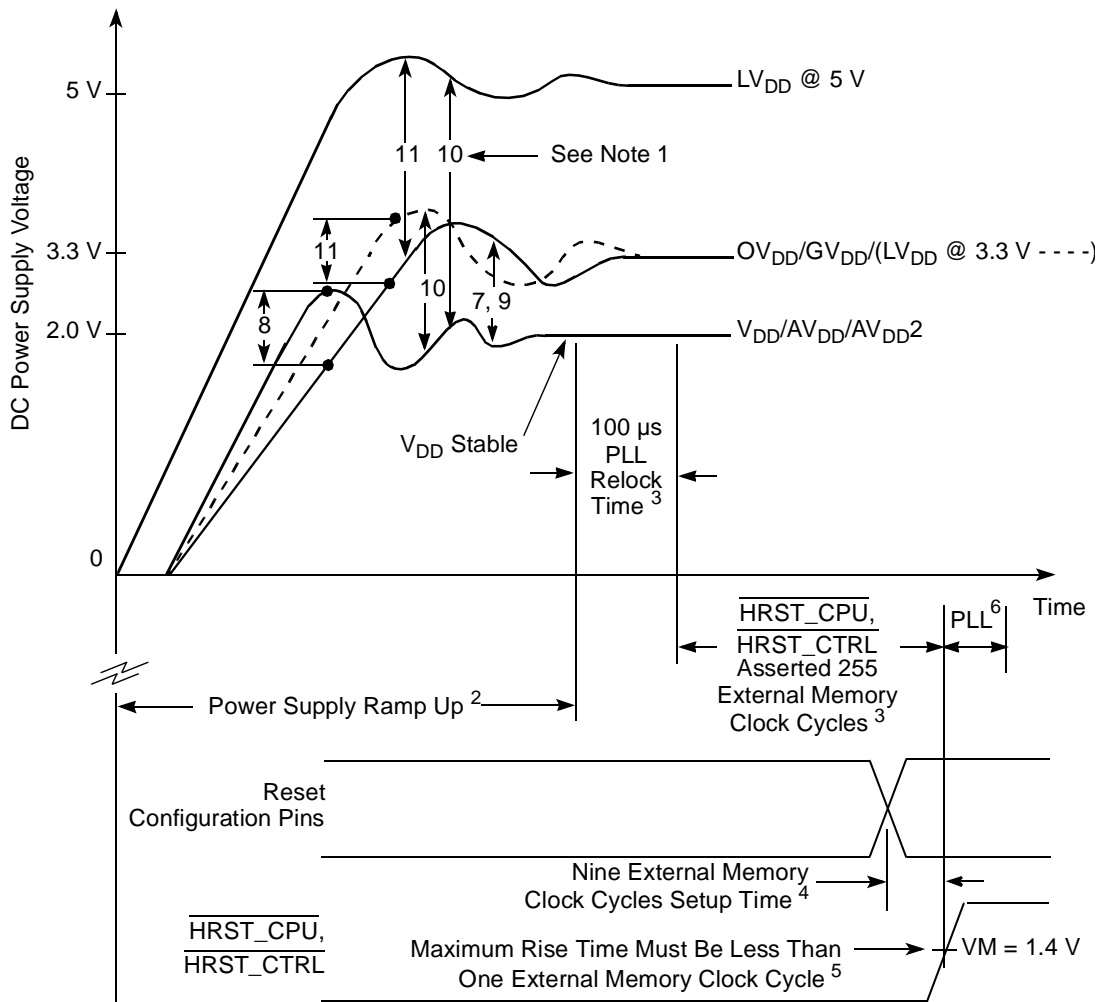

Notes:

1. Numbers associated with waveform separations correspond to caution numbers listed in Table 2.
2. See the Cautions section of Table 2 for details on this topic.
3. See Table 8 for details on PLL relock and reset signal assertion timing requirements.
4. Refer to Table 10 for additional information on reset configuration pin setup timing requirements.
5. $\overline{\text{HRST_CPU}}/\overline{\text{HRST_CTRL}}$ must transition from a logic 0 to a logic 1 in less than one SDRAM_SYNC_IN clock cycle for the device to be in the nonreset state.
6. PLL_CFG signals must be driven on reset and must be held for at least 25 clock cycles after the negation of HRST_CTRL and HRST_CPU in order to be latched.

Figure 2. Supply Voltage Sequencing and Separation Cautions

Figure 3 shows the overshoot and undershoot voltage of the memory interface.

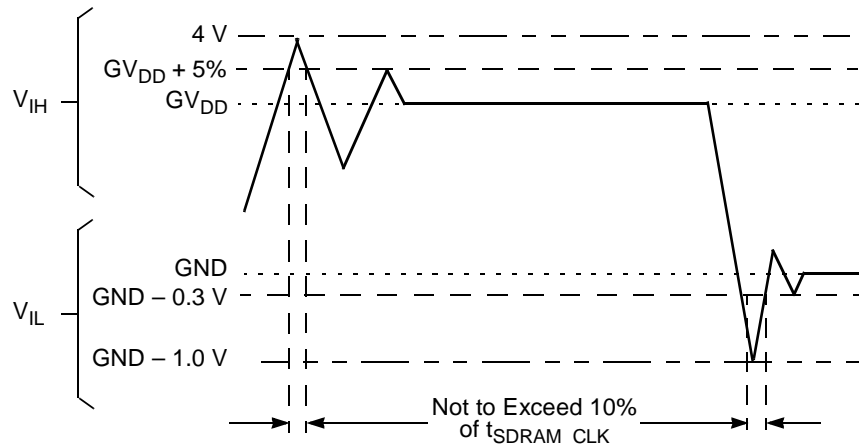

Figure 3. Overshoot/Undershoot Voltage

Figure 4 and Figure 5 show the overshoot and undershoot voltage of the PCI interface for the 3.3- and 5-V signals, respectively.

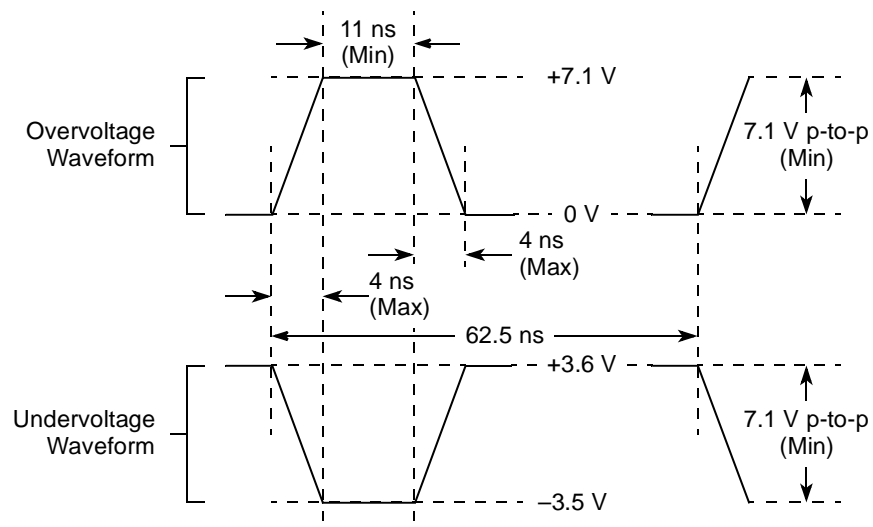

Figure 4. Maximum AC Waveforms for 3.3-V Signaling

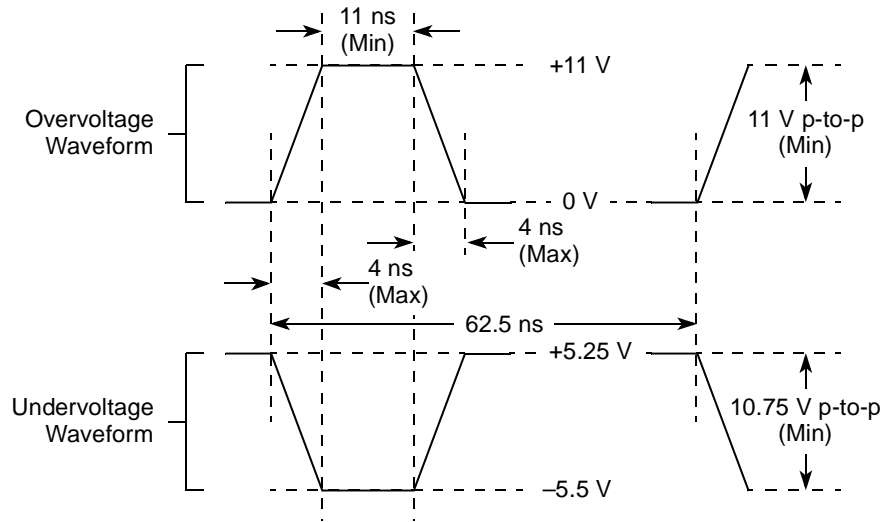

Figure 5. Maximum AC Waveforms for 5-V Signaling

4.2 DC Electrical Characteristics

Table 3 provides the DC electrical characteristics for the MPC8245 at recommended operating conditions.

Table 3. DC Electrical Specifications

At recommended operating conditions (see Table 2)

Characteristic	Condition ³	Symbol	Min	Max	Unit	Notes
Input high voltage	PCI only, except PCI_SYNC_IN	V_{IH}	$0.65 \times OV_{DD}$	LV_{DD}	V	1
Input low voltage	PCI only, except PCI_SYNC_IN	V_{IL}	—	$0.3 \times OV_{DD}$	V	
Input high voltage	All other pins, including PCI_SYNC_IN ($GV_{DD} = 3.3$ V)	V_{IH}	2.0	3.3	V	
Input low voltage	All inputs, including PCI_SYNC_IN	V_{IL}	GND	0.8	V	
Input leakage current for pins using DRV_PCI driver	0.5 V $\leq V_{in} \leq 2.7$ V @ $LV_{DD} = 4.75$ V	I_L	—	± 70	μ A	4
Input leakage current for all others	$LV_{DD} = 3.6$ V $GV_{DD} \leq 3.465$ V	I_L	—	± 10	μ A	4
Output high voltage	I_{OH} = driver-dependent ($GV_{DD} = 3.3$ V)	V_{OH}	2.4	—	V	2
Output low voltage	I_{OL} = driver-dependent ($GV_{DD} = 3.3$ V)	V_{OL}	—	0.4	V	2

Table 3. DC Electrical Specifications (continued)

At recommended operating conditions (see Table 2)

Characteristic	Condition ³	Symbol	Min	Max	Unit	Notes
Capacitance	$V_{in} = 0\text{ V}$, $f = 1\text{ MHz}$	C_{in}	—	16.0	pF	

Notes:

- See Table 16 for pins with internal pull-up resistors.
- See Table 4 for the typical drive capability of a specific signal pin based on the type of output driver associated with that pin as listed in Table 16.
- These specifications are for the default driver strengths indicated in Table 4.
- Leakage current is measured on input and output pins in the high-impedance state. The leakage current is measured for nominal OV_{DD}/LV_{DD} , and V_{DD} or both OV_{DD}/LV_{DD} and V_{DD} must vary in the same direction.

4.2.1 Output Driver Characteristics

Table 4 provides information on the characteristics of the output drivers referenced in Table 16. The values are preliminary estimates from an IBIS model and are not tested.

Table 4. Drive Capability of MPC8245 Output Pins ⁵

Driver Type	Programmable Output Impedance (Ω)	Supply Voltage	I_{OH}	I_{OL}	Unit	Notes	
DRV_STD_MEM	20 (default)	$OV_{DD} = 3.3\text{ V}$	36.6	18.0	mA	2, 4, 6	
	40		18.6	9.2	mA	2, 4, 6	
DRV_PCI	20		12.0	12.4	mA	1, 3	
	40 (default)		6.1	6.3	mA	1, 3	
DRV_MEM_CTRL	6 (default)		$GV_{DD} = 3.3\text{ V}$	89.0	42.3	mA	2, 4
DRV_PCI_CLK	20			36.6	18.0	mA	2, 4
	40	18.6		9.2	mA	2, 4	

Notes:

- For DRV_PCI, I_{OH} read from the IBIS listing in the pull-up mode, I(Min) column, at the 0.33-V label by interpolating between the 0.3- and 0.4-V table entries' current values that correspond to the PCI $V_{OH} = 2.97 = 0.9 \times OV_{DD}$ ($OV_{DD} = 3.3\text{ V}$) where table entry voltage = $OV_{DD} - PCI\ V_{OH}$.
- For all others with GV_{DD} or $OV_{DD} = 3.3\text{ V}$, I_{OH} read from the IBIS listing in the pull-up mode, I(Min) column, at the 0.9-V table entry that corresponds to the $V_{OH} = 2.4\text{ V}$ where table entry voltage = $GV_{DD}/OV_{DD} - V_{OH}$.
- For DRV_PCI, I_{OL} read from the IBIS listing in the pull-down mode, I(Min) column, at $0.33\text{ V} = PCI\ V_{OL} = 0 \times OV_{DD}$ ($OV_{DD} = 3.3\text{ V}$) by interpolating between the 0.3- and 0.4-V table entries.
- For all others with GV_{DD} or $OV_{DD} = 3.3\text{ V}$, I_{OL} read from the IBIS listing in the pull-down mode, I(Min) column, at the 0.4-V table entry.
- See driver bit details for output driver control register (0x73) in the *MPC8245 Integrated Processor Reference Manual*.
- See Chip Errata No. 19 in the *MPC8245/MPC8241 RISC Microprocessor Chip Errata*.

4.3 Power Characteristics

Table 5 provides power consumption data for the MPC8245.

Table 5. Power Consumption

Mode	PCI Bus Clock/Memory Bus Clock/CPU Clock Frequency (MHz)							Unit	Notes
	66/66/266	66/133/266	66/66/300	66/100/300	33/83/333	66/133/333	66/100/350		
Typical	1.7 (1.5)	2.0 (1.8)	1.8 (1.7)	2.0 (1.8)	2.0	2.3	2.2	W	1, 5
Max—FP	2.2 (1.9)	2.4 (2.1)	2.3 (2.0)	2.5 (2.2)	2.6	2.8	2.8	W	1, 2
Max—INT	1.8 (1.6)	2.1 (1.8)	2.0 (1.8)	2.1 (1.8)	2.2	2.4	2.4	W	1, 3
Doze	1.1 (1.0)	1.4 (1.3)	1.2 (1.1)	1.4 (1.3)	1.4	1.6	1.5	W	1, 4, 6
Nap	0.4 (0.4)	0.7 (0.7)	0.4 (0.4)	0.6 (0.6)	0.5	0.7	0.6	W	1, 4, 6
Sleep	0.2 (0.2)	0.4 (0.4)	0.2 (0.4)	0.3 (0.3)	0.3	0.4	0.3	W	1, 4, 6
I/O Power Supplies ¹⁰									
Mode	Min				Max			Unit	Notes
Typ—OV _{DD}	134 (121)				334 (301)			mW	7, 8
Typ—GV _{DD}	324 (292)				800 (720)			mW	7, 9

Notes:

- The values include V_{DD} , AV_{DD} , and AV_{DD2} but do not include I/O supply power. Information on OV_{DD} and GV_{DD} supply power is captured in the I/O power supplies section of this table. Values shown in parenthesis () indicate power consumption at $V_{DD}/AV_{DD}/AV_{DD2} = 1.8$ V.
- Maximum—FP power is measured at $V_{DD} = 2.1$ V with dynamic power management enabled while running an entirely cache-resident, looping, floating-point multiplication instruction.
- Maximum—INT power is measured at $V_{DD} = 2.1$ V with dynamic power management enabled while running entirely cache-resident, looping, integer instructions.
- Power saving mode maximums are measured at $V_{DD} = 2.1$ V while the device is in doze, nap, or sleep mode.
- Typical power is measured at $V_{DD} = AV_{DD} = 2.0$ V, $OV_{DD} = 3.3$ V where a nominal FP value, a nominal INT value, and a value where there is a continuous flush of cache lines with alternating ones and zeros on 64-bit boundaries to local memory are averaged.
- Power saving mode data measured with only two PCI_CLKs and two SDRAM_CLKs enabled.
- The typical minimum I/O power values were results of the MPC8245 performing cache resident integer operations at the slowest frequency combination of 33:66:200 (PCI:Mem:CPU) MHz.
- The typical maximum OV_{DD} value resulted from the MPC8245 operating at the fastest frequency combination of 66:100:350 (PCI:Mem:CPU) MHz and performing continuous flushes of cache lines with alternating ones and zeros to PCI memory.
- The typical maximum GV_{DD} value resulted from the MPC8245 operating at the fastest frequency combination of 66:100:350 (PCI:Mem:CPU) MHz and performing continuous flushes of cache lines with alternating ones and zeros on 64-bit boundaries to local memory.
- Power consumption of PLL supply pins (AV_{DD} and AV_{DD2}) < 15 mW. Guaranteed by design and not tested.

4.4 Thermal Characteristics

Table 6 provides the package thermal characteristics for the MPC8245. For details, see [Section 7.8](#), “Thermal Management.”

Table 6. Thermal Characteristics

Characteristic	Symbol	Value	Unit	Notes
Junction-to-ambient natural convection (Single-layer board—1s)	$R_{\theta JA}$	16.1	°C/W	1, 2
Junction-to-ambient natural convection (Four-layer board—2s2p)	$R_{\theta JMA}$	12.0	°C/W	1, 3
Junction-to-ambient (@200 ft/min) (Single-layer board—1s)	$R_{\theta JMA}$	11.6	°C/W	1, 3
Junction-to-ambient (@200 ft/min) (Four layer board—2s2p)	$R_{\theta JMA}$	9.0	°C/W	1, 3
Junction-to-board	$R_{\theta JB}$	4.8	°C/W	4
Junction-to-case	$R_{\theta JC}$	1.8	°C/W	5
Junction-to-package top (natural convection)	Ψ_{JT}	1.0	°C/W	6

Notes:

1. Junction temperature is a function of die size, on-chip power dissipation, package thermal resistance, mounting site (board) temperature, ambient temperature, airflow, power dissipation of other components on the board, and board thermal resistance.
2. Per SEMI G38-87 and JEDEC JESD51-2 with the single-layer board horizontal.
3. Per JEDEC JESD51-6 with the board horizontal.
4. Thermal resistance between the die and the printed-circuit board per JEDEC JESD51-8. Board temperature is measured on the top surface of the board near the package.
5. Thermal resistance between the die and the case top surface as measured by the cold plate method (MIL SPEC-883 Method 1012.1) with the cold plate used for case temperature.
6. Thermal characterization parameter indicating the temperature difference between the package top and the junction temperature per JEDEC JESD51-2. When Greek letters are not available, the thermal characterization parameter is written as Psi-JT.

4.5 AC Electrical Characteristics

After fabrication, functional parts are sorted by maximum processor core frequency as shown in [Table 7](#) and tested for conformance to the AC specifications for that frequency. The processor core frequency is determined by the bus (PCI_SYNC_IN) clock frequency and the settings of the PLL_CFG[0:4] signals. Parts are sold by maximum processor core frequency. See [Section 9](#), “Ordering Information,” for details on ordering parts.

Table 7 provides the operating frequency information for the MPC8245 at recommended operating conditions (see Table 2) with $V_{DD} = 3.3 \text{ V} \pm 0.3 \text{ V}$.

Table 7. Operating Frequency ¹

Characteristic ^{2, 3}	266 MHz	300 MHz	333 MHz	350 MHz	Unit
	$V_{DD}/AV_{DD}/AV_{DD2} = 1.8/1.9/2.0 \text{ V} \pm 100 \text{ mV}$		$V_{DD}/AV_{DD}/AV_{DD2} = 2.0/2.1 \text{ V} \pm 100 \text{ mV}$		
Processor frequency (CPU)	100–266	100–300	100–333	100–350	MHz
Memory bus frequency	50–133	50–100 ⁴	50–133	50–100 ⁴	MHz
PCI input frequency	25–66				MHz

Notes:

- For details, refer to the hardware specifications addendum MPC8245ECSO2AD.
- Caution:** The PCI_SYNC_IN frequency and PLL_CFG[0:4] settings must be chosen such that the resulting peripheral logic/memory bus frequency and CPU (core) frequencies do not exceed their respective maximum or minimum operating frequencies. Refer to the PLL_CFG[0:4] signal description in Section 6, “PLL Configurations,” for valid PLL_CFG[0:4] settings and PCI_SYNC_IN frequencies.
- See Table 17 and Table 18 for details on VCO limitations for memory and CPU VCO frequencies of various PLL configurations.
- No available PLL_CFG[0:4] settings support 133-MHz memory interface operation at 300- and 350-MHz CPU operation, since the multipliers do not allow a 300:133 and 350:133 ratio relation. However, running these parts at slower processor speeds may produce ratios that run above 100 MHz. See Table 17 for the PLL settings.

4.5.1 Clock AC Specifications

Table 8 provides the clock AC timing specifications at recommended operating conditions, as defined in Section 4.5.2, “Input AC Timing Specifications.” These specifications are for the default driver strengths indicated in Table 4.

Table 8. Clock AC Timing Specifications

At recommended operating conditions (see Table 2) with $V_{DD} = 3.3 \text{ V} \pm 0.3 \text{ V}$

Num	Characteristics and Conditions	Min	Max	Unit	Notes
1	Frequency of operation (PCI_SYNC_IN)	25	66	MHz	
2, 3	PCI_SYNC_IN rise and fall times	—	2.0	ns	1
4	PCI_SYNC_IN duty cycle measured at 1.4 V	40	60	%	
5a	PCI_SYNC_IN pulse width high measured at 1.4 V	6	9	ns	2
5b	PCI_SYNC_IN pulse width low measured at 1.4 V	6	9	ns	2
7	PCI_SYNC_IN jitter	—	200	ps	
8a	PCI_CLK[0:4] skew (pin-to-pin)	—	250	ps	
8b	SDRAM_CLK[0:3] skew (pin-to-pin)	—	190	ps	3
10	Internal PLL relock time	—	100	μs	2, 4, 5
15	DLL lock range with DLL_EXTEND = 0 (disabled) and normal tap delay; (default DLL mode)	See Figure 7		ns	6

Table 8. Clock AC Timing Specifications (continued)

 At recommended operating conditions (see Table 2) with $V_{DD} = 3.3 \text{ V} \pm 0.3 \text{ V}$

Num	Characteristics and Conditions	Min	Max	Unit	Notes
16	DLL lock range for other modes	See Figure 8 through Figure 10		ns	6
17	Frequency of operation (OSC_IN)	25	66	MHz	
19	OSC_IN rise and fall times	—	5	ns	7
20	OSC_IN duty cycle measured at 1.4 V	40	60	%	
21	OSC_IN frequency stability	—	100	ppm	

Notes:

- Rise and fall times for the PCI_SYNC_IN input are measured from 0.4 to 2.4 V.
- Specification value at maximum frequency of operation.
- Pin-to-pin skew includes quantifying the additional amount of clock skew (or jitter) from the DLL besides any intentional skew added to the clocking signals from the variable length DLL synchronization feedback loop, that is, the amount of variance between the internal *sys_logic_clk* and the SDRAM_SYNC_IN signal after the DLL is locked. While pin-to-pin skew between SDRAM_CLKs can be measured, the relationship between the internal *sys_logic_clk* and the external SDRAM_SYNC_IN cannot be measured and is guaranteed by design.
- Relock time is guaranteed by design and characterization. Relock time is not tested.
- Relock timing is guaranteed by design. PLL-relock time is the maximum amount of time required for PLL lock after a stable V_{DD} and PCI_SYNC_IN are reached during the reset sequence. This specification also applies when the PLL has been disabled and subsequently re-enabled during sleep mode. Also note that HRST_CPU/HRST_CTRL must be held asserted for a minimum of 255 bus clocks after the PLL-relock time during the reset sequence.
- DLL_EXTEND is bit 7 of the PMC2 register <72>. N is a non-zero integer (see Figure 7 through Figure 10). T_{clk} is the period of one SDRAM_SYNC_OUT clock cycle in ns. T_{loop} is the propagation delay of the DLL synchronization feedback loop (PC board runner) from SDRAM_SYNC_OUT to SDRAM_SYNC_IN in ns; 6.25 inches of loop length (unloaded PC board runner) corresponds to approximately 1 ns of delay. For details about how Figure 7 through Figure 10 may be used refer to the Freescale application note AN2164, *MPC8245/MPC8241 Memory Clock Design Guidelines*, for details on MPC8245 memory clock design.
- Rise and fall times for the OSC_IN input is guaranteed by design and characterization. OSC_IN input rise and fall times are not tested.

Figure 6 shows the PCI_SYNC_IN input clock timing diagram with the labeled number items listed in Table 8.

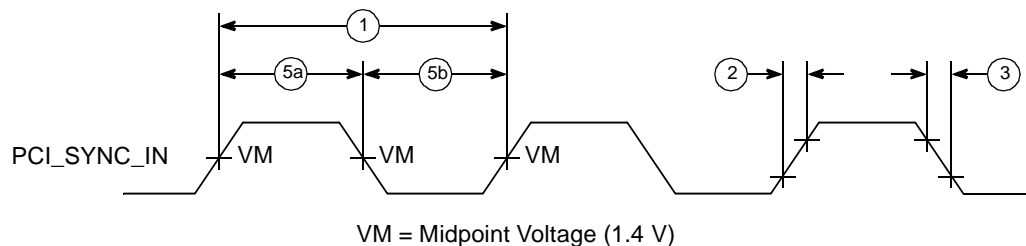

Figure 6. PCI_SYNC_IN Input Clock Timing Diagram

Figure 7 through Figure 10 show the DLL locking range loop delay vs. frequency of operation. These graphs define the areas of DLL locking for various modes. The gray areas show where the DLL locks.

Register settings that define each DLL mode are shown in [Table 9](#).

Table 9. DLL Mode Definition

DLL Mode	Bit 2 of Configuration Register at 0x76	Bit 7 of Configuration Register at 0x72
Normal tap delay, No DLL extend	0	0
Normal tap delay, DLL extend	0	1
Max tap delay, No DLL extend	1	0
Max tap delay, DLL extend	1	1

The DLL_MAX_DELAY bit can lengthen the amount of time through the delay line by increasing the time between each of the 128 tap points in the delay line. Although this increased time makes it easier to guarantee that the reference clock is within the DLL lock range, there may be slightly more jitter in the output clock of the DLL; that is, the phase comparator shifts the clock between adjacent tap points. Refer to the Freescale application note AN2164, *MPC8245/MPC8241 Memory Clock Design Guidelines: Part 1*, for details on DLL modes and memory design.

The value of the current tap point after the DLL locks can be determined by reading bits 6–0 (DLL_TAP_COUNT) of the DLL tap count register (DTCR, located at offset 0xE3). These bits store the value (binary 0 through 127) of the current tap point and can indicate whether the DLL advances or decrements as it maintains the DLL lock. Therefore, for evaluation purposes, DTCR can be read for all DLL modes that support the T_{loop} value used for the trace length of SDRAM_SYNC_OUT to SDRAM_SYNC_IN. The DLL mode with the smallest tap point value in the DTCR should be used because the bigger the tap point value, the more jitter that can be expected for clock signals. Note that keeping a DLL mode that is locked below tap point decimal 12 is not recommended.

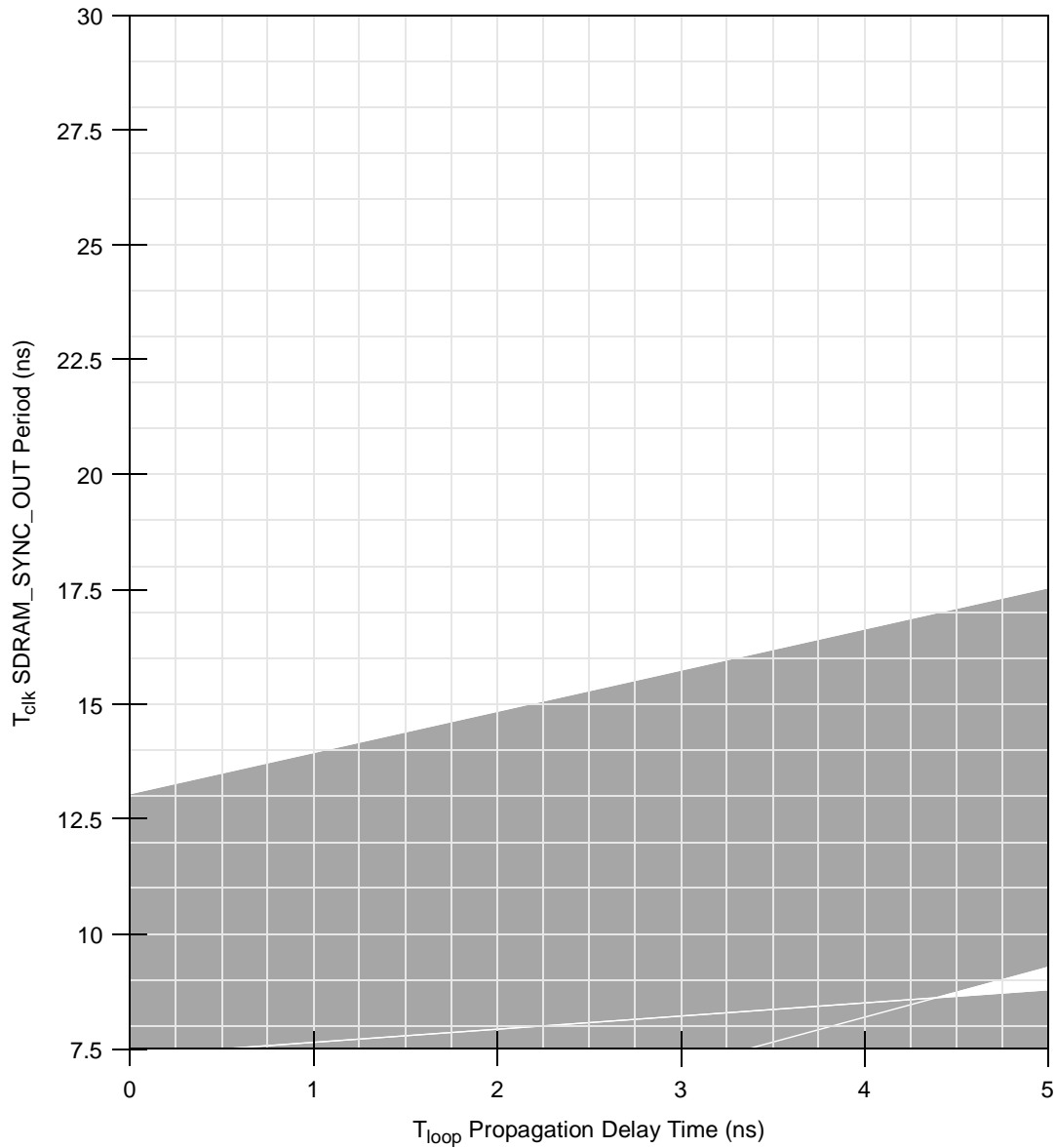

Figure 7. DLL Locking Range Loop Delay Versus Frequency of Operation for DLL_Extend=0 and Normal Tap Delay

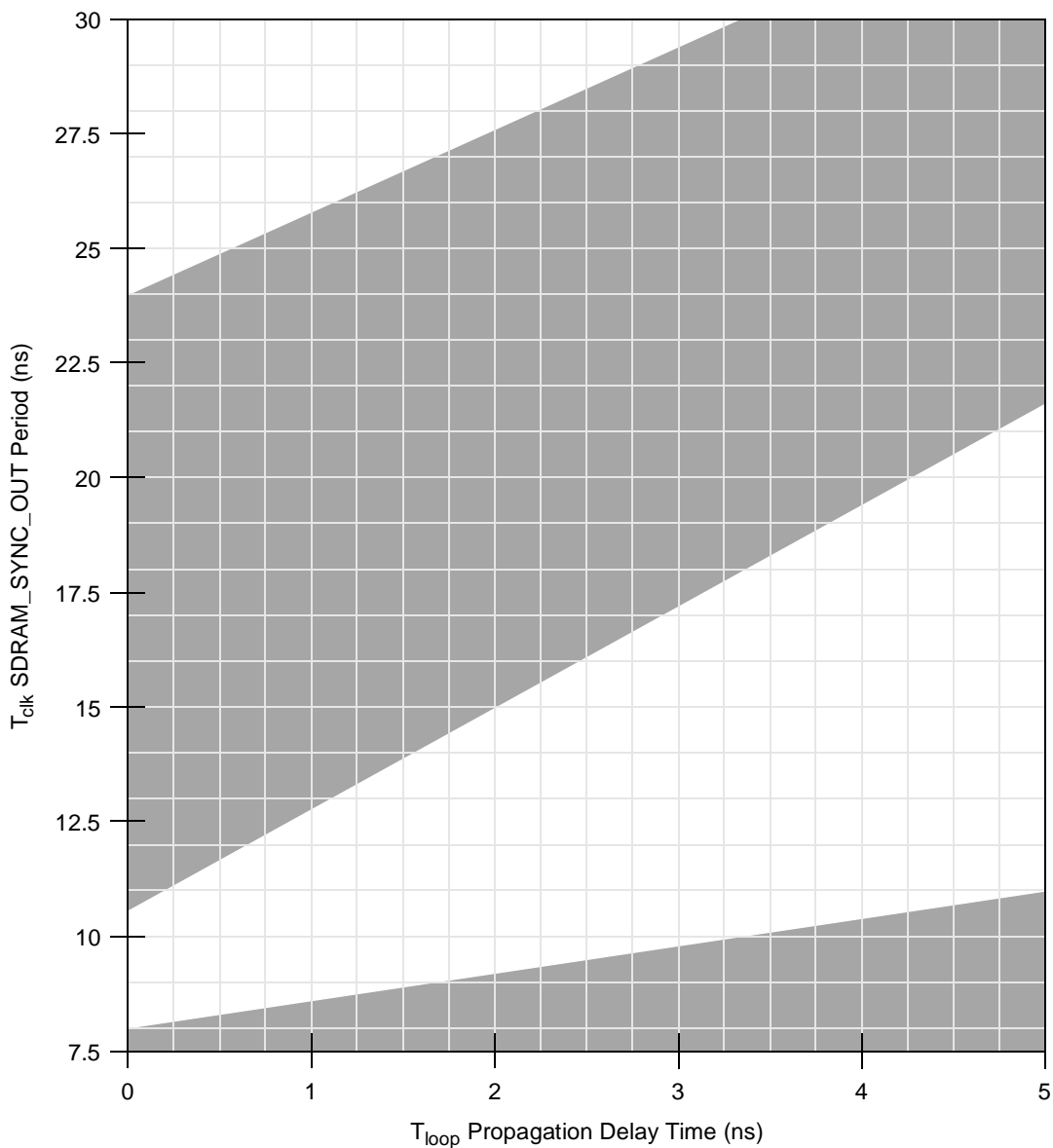

Figure 8. DLL Locking Range Loop Delay Versus Frequency of Operation for DLL_Extend=1 and Normal Tap Delay

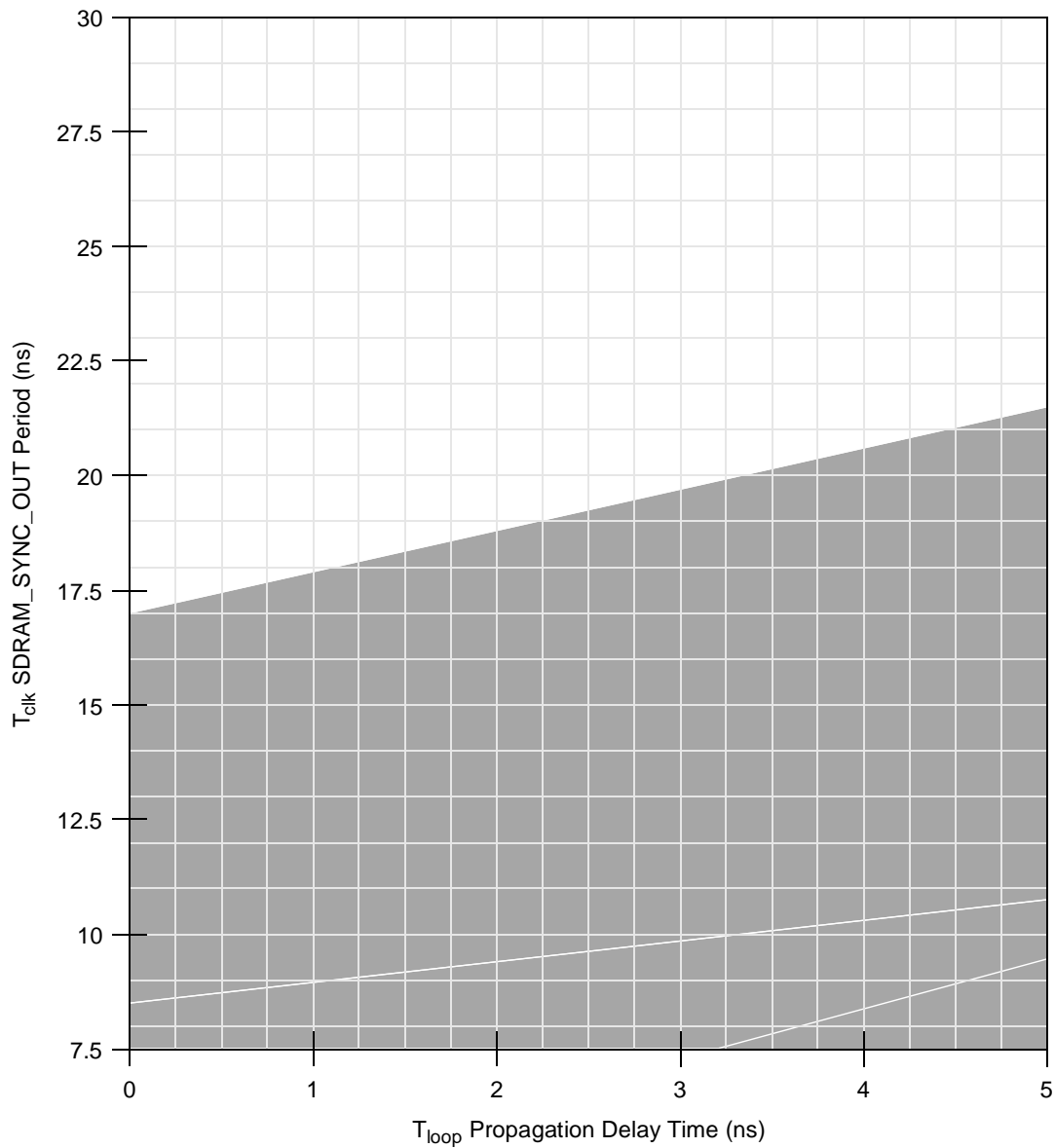

Figure 9. DLL Locking Range Loop Delay Versus Frequency of Operation for DLL_Extend=0 and Max Tap Delay

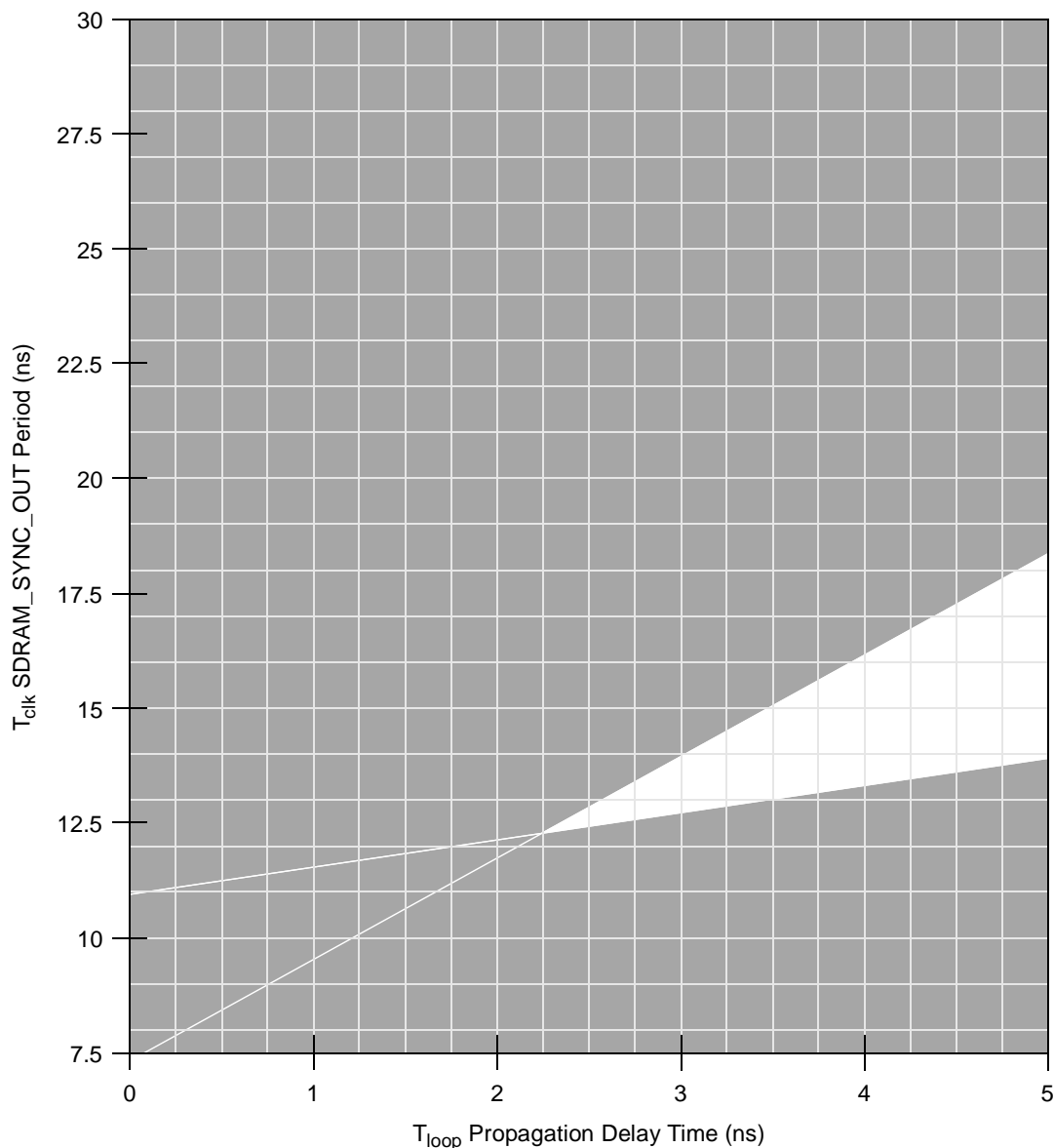

Figure 10. DLL Locking Range Loop Delay Versus Frequency of Operation for DLL_Extend=1 and Max Tap Delay

4.5.2 Input AC Timing Specifications

Table 10 provides the input AC timing specifications at recommended operating conditions (see Table 2) with $V_{DD} = 3.3 \text{ V} \pm 0.3 \text{ V}$.

Table 10. Input AC Timing Specifications

Num	Characteristic	Min	Max	Unit	Notes
10a	PCI input signals valid to PCI_SYNC_IN (input setup)	3.0	—	ns	1, 3
10b	Memory input signals valid to <i>sys_logic_clk</i> (input setup)				
10b0	Tap 0, register offset <0x77>, bits 5–4 = 0b00	2.6	—	ns	2, 3, 6
10b1	Tap 1, register offset <0x77>, bits 5–4 = 0b01	1.9	—		
10b2	Tap 2, register offset <0x77>, bits 5–4 = 0b10 (default)	1.2	—		
10b3	Tap 3, register offset <0x77>, bits 5–4 = 0b11	0.5	—		
10c	PIC, misc. debug input signals valid to <i>sys_logic_clk</i> (input setup)	3.0	—	ns	2, 3
10d	I ² C input signals valid to <i>sys_logic_clk</i> (input setup)	3.0	—	ns	2, 3
10e	Mode select inputs valid to $\overline{\text{HRST_CPU/HRST_CTRL}}$ (input setup)	$9 \times t_{\text{CLK}}$	—	ns	2, 3–5
11	T_{os} —SDRAM_SYNC_IN to <i>sys_logic_clk</i> offset time	0.4	1.0	ns	7
11a	<i>sys_logic_clk</i> to memory signal inputs invalid (input hold)				
11a0	Tap 0, register offset <0x77>, bits 5–4 = 0b00	0	—	ns	2, 3, 6
11a1	Tap 1, register offset <0x77>, bits 5–4 = 0b01	0.7	—		
11a2	Tap 2, register offset <0x77>, bits 5–4 = 0b10 (default)	1.4	—		
11a3	Tap 3, register offset <0x77>, bits 5–4 = 0b11	2.1	—		
11b	$\overline{\text{HRST_CPU/HRST_CTRL}}$ to mode select inputs invalid (input hold)	0	—	ns	2, 3, 5
11c	PCI_SYNC_IN to Inputs invalid (input hold)	1.0	—	ns	1, 2, 3

Notes:

- All PCI signals are measured from $OV_{\text{DD}}/2$ of the rising edge of PCI_SYNC_IN to $0.4 \times OV_{\text{DD}}$ of the signal in question for 3.3-V PCI signaling levels. See [Figure 12](#).
- All memory and related interface input signal specifications are measured from the TTL level (0.8 or 2.0 V) of the signal in question to the $VM = 1.4$ V of the rising edge of the memory bus clock, *sys_logic_clk*. *sys_logic_clk* is the same as PCI_SYNC_IN in 1:1 mode but is twice the frequency in 2:1 mode (processor/memory bus clock rising edges occur on every rising and falling edge of PCI_SYNC_IN). See [Figure 11](#).
- Input timings are measured at the pin.
- t_{CLK} is the time of one SDRAM_SYNC_IN clock cycle.
- All mode select input signals specifications are measured from the TTL level (0.8 or 2.0 V) of the signal in question to the $VM = 1.4$ V of the rising edge of the $\overline{\text{HRST_CPU/HRST_CTRL}}$ signal. See [Figure 13](#).
- The memory interface input setup and hold times are programmable to four possible combinations by programming bits 5–4 of register offset <0x77> to select the desired input setup and hold times.
- T_{os} represents a timing adjustment for SDRAM_SYNC_IN with respect to *sys_logic_clk*. Due to the internal delay present on the SDRAM_SYNC_IN signal with respect to the *sys_logic_clk* inputs to the DLL, the resulting SDRAM clocks become offset by the delay amount. To maintain phase-alignment of the memory clocks with respect to *sys_logic_clk*, the feedback trace length of SDRAM_SYNC_OUT to SDRAM_SYNC_IN must be shortened to accommodate this range. The feedback trace length is relative to the SDRAM clock output trace lengths. We recommend that the length of SDRAM_SYNC_OUT to SDRAM_SYNC_IN be shortened by 0.7 ns because that is the midpoint of the range of T_{os} and allows the impact from the range of T_{os} to be reduced. Additional analyses of trace lengths and SDRAM loading must be performed to optimize timing. For details on trace measurements and the problem of T_{os} , refer to the Freescale application note AN2164, *MPC8245/MPC8241 Memory Clock Design Guidelines*.

Figure 11 and Figure 12 show the input/output timing diagrams referenced to SDRAM_SYNC_IN and PCI_SYNC_IN, respectively.

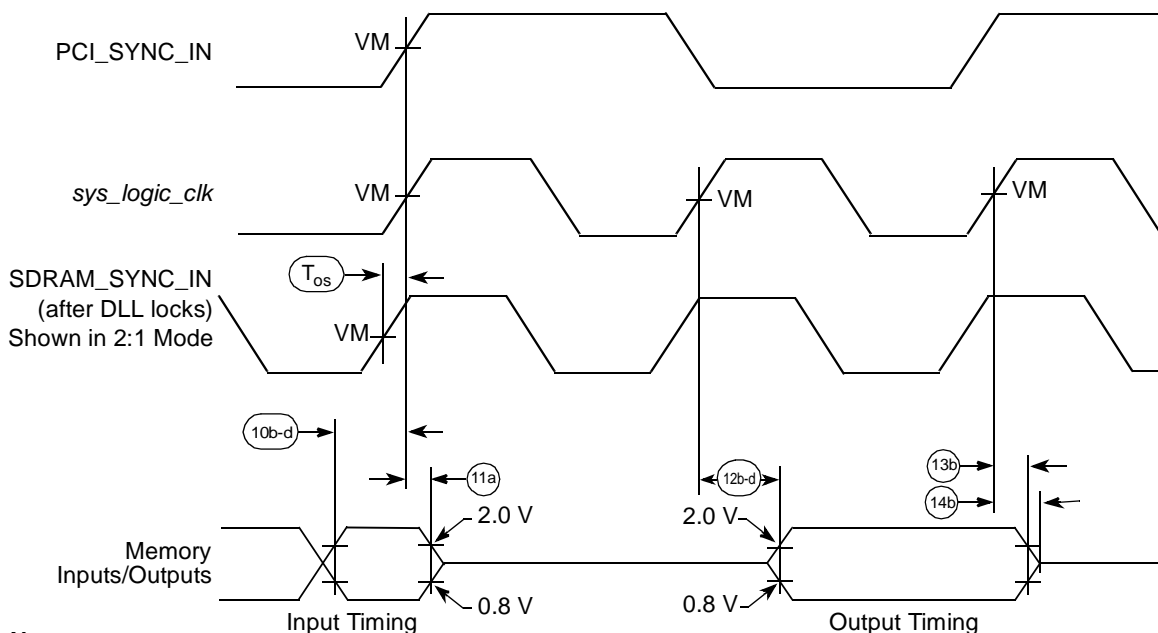

Notes:

- VM = Midpoint voltage (1.4 V).
- 10b-d = Input signals valid timing.
- 11a = Input hold time of SDRAM_SYNC_IN to memory.
- 12b-d = *sys_logic_clk* to output valid timing.
- 13b = Output hold time for non-PCI signals.
- 14b = SDRAM_SYNC_IN to output high-impedance timing for non-PCI signals.
- T_{os} = Offset timing required to align *sys_logic_clk* with SDRAM_SYNC_IN. The SDRAM_SYNC_IN signal is adjusted by the DLL to accommodate for internal delay. This causes SDRAM_SYNC_IN to appear before *sys_logic_clk* once the DLL locks.

Figure 11. Input/Output Timing Diagram Referenced to SDRAM_SYNC_IN

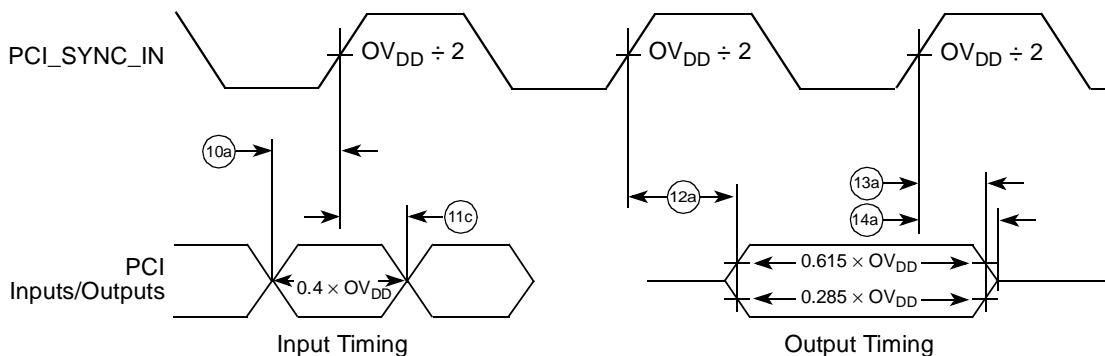

Figure 12. Input/Output Timing Diagram Referenced to PCI_SYNC_IN

Figure 13 shows the input timing diagram for mode select signals.

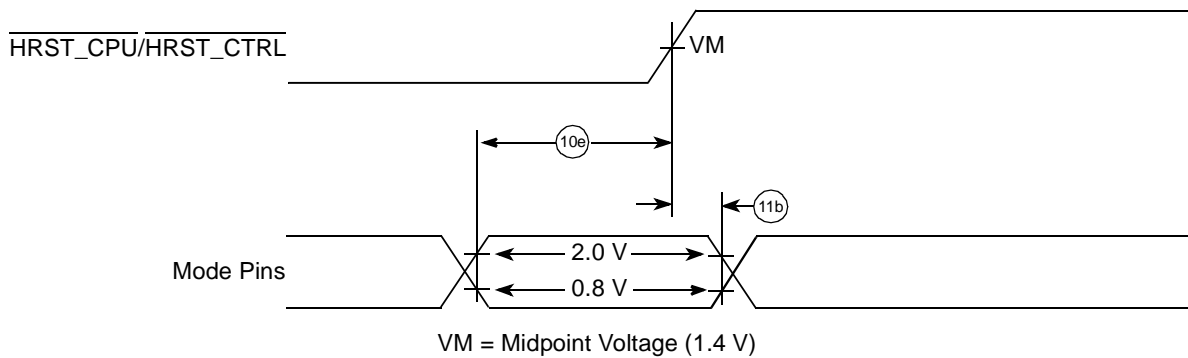

Figure 13. Input Timing Diagram for Mode Select Signals

4.5.3 Output AC Timing Specification

Table 11 provides the processor bus AC timing specifications for the MPC8245 at recommended operating conditions (see Table 2) with $V_{DD} = 3.3 \text{ V} \pm 0.3 \text{ V}$. See Figure 11 for the input/output timing diagram referenced to *sys_logic_clk*. All output timings assume a purely resistive 50-Ω load (see Figure 14 for the AC test load for the MPC8245). Output timings are measured at the pin; time-of-flight delays must be added for trace lengths, vias, and connectors in the system. These specifications are for the default driver strengths indicated in Table 4.

Table 11. Output AC Timing Specifications

Num	Characteristic	Min	Max	Unit	Notes
12a	PCI_SYNC_IN to output valid, see Figure 15				
12a0	Tap 0, PCI_HOLD_DEL=00, [MCP,CKE] = 11, 66 MHz PCI (default)	—	6.0	ns	1, 3
12a1	Tap 1, PCI_HOLD_DEL=01, [MCP,CKE] = 10	—	6.5		
12a2	Tap 2, PCI_HOLD_DEL=10, [MCP,CKE] = 01, 33 MHz PCI	—	7.0		
12a3	Tap 3, PCI_HOLD_DEL=11, [MCP,CKE] = 00	—	7.5		
12b	<i>sys_logic_clk</i> to output valid (memory control, address, and data signals)	—	4.0	ns	2
12c	<i>sys_logic_clk</i> to output valid (for all others)	—	7.0	ns	2
12d	<i>sys_logic_clk</i> to output valid (for I ² C)	—	5.0	ns	2
12e	<i>sys_logic_clk</i> to output valid (ROM/Flash/PortX)	—	6.0	ns	2
13a	Output hold (PCI), see Figure 15				
13a0	Tap 0, PCI_HOLD_DEL=00, [MCP,CKE] = 11, 66-MHz PCI (default)	2.0	—	ns	1, 3, 4
13a1	Tap 1, PCI_HOLD_DEL=01, [MCP,CKE] = 10	2.5	—		
13a2	Tap 2, PCI_HOLD_DEL=10, [MCP,CKE] = 01, 33-MHz PCI	3.0	—		
13a3	Tap 3, PCI_HOLD_DEL=11, [MCP,CKE] = 00	3.5	—		
13b	Output hold (all others)	1.0	—	ns	2
14a	PCI_SYNC_IN to output high impedance (for PCI)	—	14.0	ns	1, 3

Table 11. Output AC Timing Specifications (continued)

Num	Characteristic	Min	Max	Unit	Notes
14b	<i>sys_logic_clk</i> to output high impedance (for all others)	—	4.0	ns	2

Notes:

- All PCI signals are measured from $GV_{DD}/2$ of the rising edge of *PCI_SYNC_IN* to $0.285 \times OV_{DD}$ or $0.615 \times OV_{DD}$ of the signal in question for 3.3 V PCI signaling levels. See [Figure 12](#).
- All memory and related interface output signal specifications are specified from the $VM = 1.4$ V of the rising edge of the memory bus clock, *sys_logic_clk* to the TTL level (0.8 or 2.0 V) of the signal in question. *sys_logic_clk* is the same as *PCI_SYNC_IN* in 1:1 mode, but is twice the frequency in 2:1 mode (processor/memory bus clock rising edges occur on every rising and falling edge of *PCI_SYNC_IN*). See [Figure 11](#).
- PCI based signals are composed of the following signals: \overline{LOCK} , \overline{IRDY} , $\overline{C/BE[3:0]}$, \overline{PAR} , \overline{TRDY} , \overline{FRAME} , \overline{STOP} , \overline{DEVSEL} , \overline{PERR} , \overline{SERR} , $AD[31:0]$, $REQ[4:0]$, $GNT[4:0]$, $IDSEL$, and $INTA$.
- To meet minimum output hold specifications relative to *PCI_SYNC_IN* for both 33- and 66-MHz PCI systems, the MPC8245 has a programmable output hold delay for PCI signals (the *PCI_SYNC_IN* to output valid timing is also affected). The initial value of the output hold delay is determined by the values on the \overline{MCP} and \overline{CKE} reset configuration signals; the values on these two signals are inverted and stored as the initial settings of $PCI_HOLD_DEL = PMCR2[5, 4]$ (power management configuration register 2 <0x72>), respectively. Since \overline{MCP} and \overline{CKE} have internal pull-up resistors, the default value of PCI_HOLD_DEL after reset is 0b00. Further output hold delay values are available by programming the PCI_HOLD_DEL value of the $PMCR2$ configuration register. [Figure 15](#) shows the PCI_HOLD_DEL effect on output valid and hold times.

[Figure 14](#) provides the AC test load for the MPC8245.

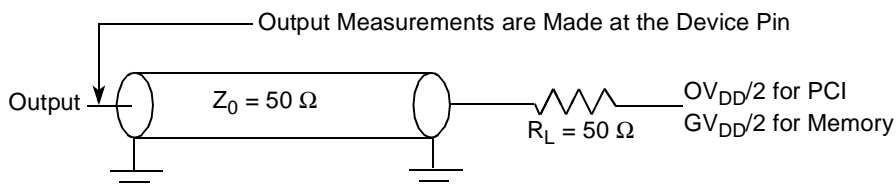
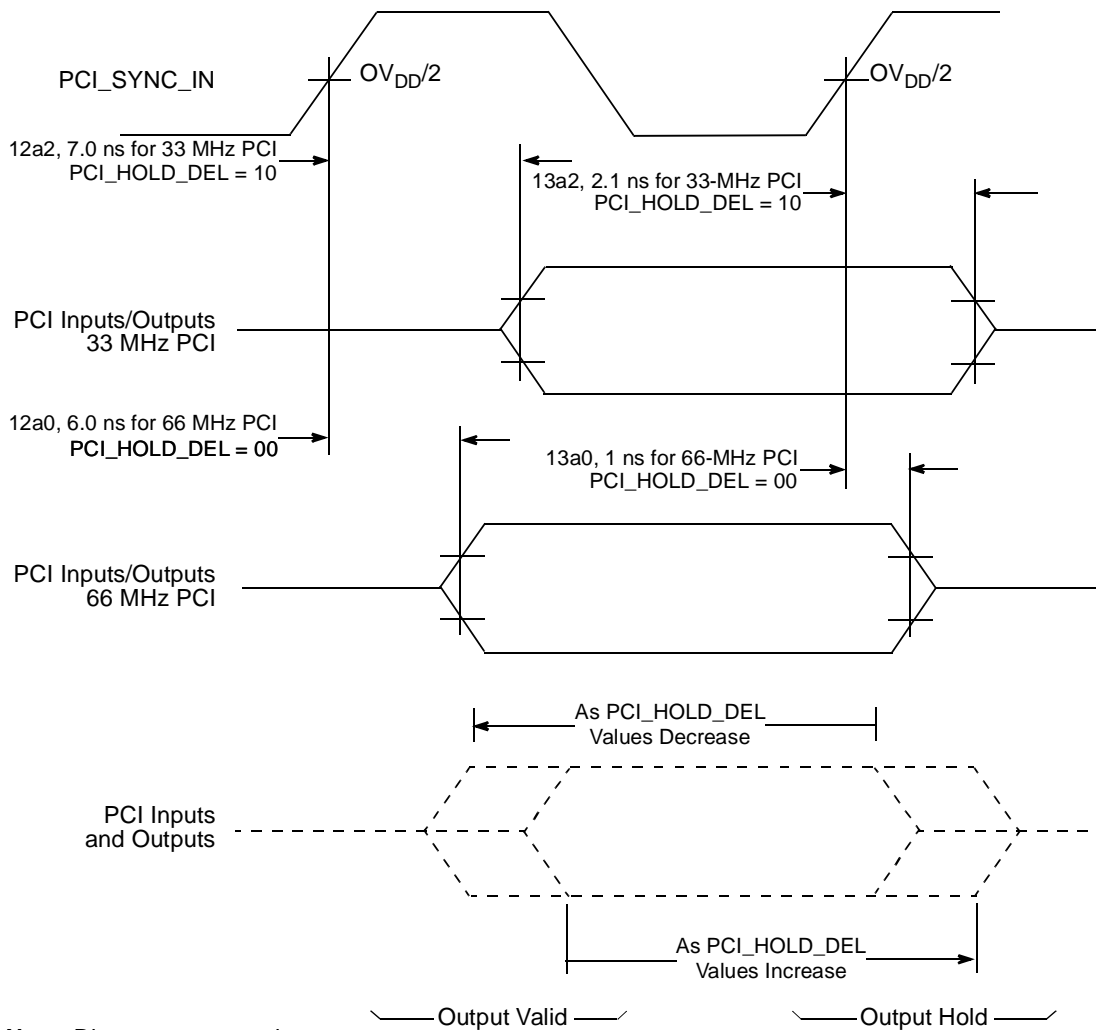

Figure 14. AC Test Load for the MPC8245

Figure 15 provides the PCI_HOLD_DEL effect on output valid and hold times.



Note: Diagram not to scale.

Figure 15. PCI_HOLD_DEL Effect on Output Valid and Hold Times

4.6 I²C

This section describes the DC and AC electrical characteristics for the I²C interfaces of the MPC8245.

4.6.1 I²C DC Electrical Characteristics

Table 12 provides the DC electrical characteristics for the I²C interfaces.

Table 12. I²C DC Electrical Characteristics

At recommended operating conditions with OV_{DD} of $3.3\text{ V} \pm 5\%$.

Parameter	Symbol	Min	Max	Unit	Notes
Input high voltage level	V_{IH}	$0.7 \times OV_{DD}$	$OV_{DD} + 0.3$	V	
Input low voltage level	V_{IL}	-0.3	$0.3 \times OV_{DD}$	V	
Low-level output voltage	V_{OL}	0	$0.2 \times OV_{DD}$	V	1

Table 12. I²C DC Electrical Characteristics

 At recommended operating conditions with OV_{DD} of $3.3\text{ V} \pm 5\%$.

Pulse width of spikes which must be suppressed by the input filter	t_{12KHKL}	0	50	ns	2
Input current each I/O pin (input voltage is between $0.1 \times OV_{DD}$ and $0.9 \times OV_{DD}(\text{max})$)	I_I	-10	10	μA	3
Capacitance for each I/O pin	C_I	—	10	pF	

Notes:

1. Output voltage (open drain or open collector) condition = 3 mA sink current.
2. Refer to the *MPC8245 Integrated Processor Reference Manual* for information on the digital filter used.
3. I/O pins obstruct the SDA and SCL lines if the OV_{DD} is switched off.

4.6.2 I²C AC Electrical Specifications

 Table 13 provides the AC timing parameters for the I²C interfaces.

Table 13. I²C AC Electrical Specifications

 All values refer to V_{IH} (min) and V_{IL} (max) levels (see Table 12).

Parameter	Symbol ¹	Min	Max	Unit
SCL clock frequency	f_{12C}	0	400	kHz
Low period of the SCL clock	t_{12CL} ⁴	1.3	—	μs
High period of the SCL clock	t_{12CH} ⁴	0.6	—	μs
Setup time for a repeated START condition	t_{12SVKH} ⁴	0.6	—	μs
Hold time (repeated) START condition (after this period, the first clock pulse is generated)	t_{12SXKL} ⁴	0.6	—	μs
Data setup time	t_{12DVKH} ⁴	100	—	ns
Data input hold time: CBUS compatible masters I ² C bus devices	t_{12DXKL}	— 0 ²	— —	μs
Data output delay time:	t_{12OVKL}	—	0.9 ³	
Set-up time for STOP condition	t_{12PVKH}	0.6	—	μs
Bus free time between a STOP and START condition	t_{12KHDX}	1.3	—	μs
Noise margin at the LOW level for each connected device (including hysteresis)	V_{NL}	$0.1 \times OV_{DD}$	—	V

Table 13. I²C AC Electrical Specifications (continued)

 All values refer to V_{IH} (min) and V_{IL} (max) levels (see Table 12).

Parameter	Symbol ¹	Min	Max	Unit
Noise margin at the HIGH level for each connected device (including hysteresis)	V_{NH}	$0.2 \times OV_{DD}$	—	V

Note:

- The symbols used for timing specifications follow the pattern of $t_{(\text{first two letters of functional block})(\text{signal})(\text{state}) (\text{reference})(\text{state})}$ for inputs and $t_{(\text{first two letters of functional block})(\text{reference})(\text{state})(\text{signal})(\text{state})}$ for outputs. For example, t_{I2DVKH} symbolizes I²C timing (I2) with respect to the time data input signals (D) reach the valid state (V) relative to the t_{I2C} clock reference (K) going to the high (H) state or setup time. Also, t_{I2SXKL} symbolizes I²C timing (I2) for the time that the data with respect to the start condition (S) went invalid (X) relative to the t_{I2C} clock reference (K) going to the low (L) state or hold time. Also, t_{I2PVKH} symbolizes I²C timing (I2) for the time that the data with respect to the stop condition (P) reaching the valid state (V) relative to the t_{I2C} clock reference (K) going to the high (H) state or setup time. For rise and fall times, the latter convention is used with the appropriate letter: R (rise) or F (fall).
- As a transmitter, the MPC8245 provides a delay time of at least 300 ns for the SDA signal (referred to as the V_{ihmin} of the SCL signal) to bridge the undefined region of the falling edge of SCL to avoid unintended generation of Start or Stop condition. When the MPC8245 acts as the I²C bus master while transmitting, it drives both SCL and SDA. As long as the load on SCL and SDA is balanced, the MPC8245 does not cause the unintended generation of a Start or Stop condition. Therefore, the 300 ns SDA output delay time is not a concern. If, under some rare condition, the 300 ns SDA output delay time is required for the MPC8245 as transmitter, the following setting is recommended for the FDR bit field of the I2CFDR register to ensure both the desired I²C SCL clock frequency and SDA output delay time are achieved. It is assumed that the desired I²C SCL clock frequency is 400 KHz and the digital filter sampling rate register (DFFSR bits in I2CFDR) is programmed with its default setting of 0x10 (decimal 16):

SDRAM Clock Frequency	100 MHz	133 MHz
FDR Bit Setting	0x00	0x2A
Actual FDR Divider Selected	384	896
Actual I ² C SCL Frequency Generated	260.4 KHz	148.4 KHz

 For details on I²C frequency calculation, refer to the application note AN2919 “Determining the I²C Frequency Divider Ratio for SCL”.
- The maximum t_{I2DXKL} has only to be met if the device does not stretch the LOW period (t_{I2CL}) of the SCL signal.
- Guaranteed by design.

 Figure 16 provides the AC test load for the I²C.

Figure 16. I²C AC Test Load

Figure 17 shows the AC timing diagram for the I²C bus.

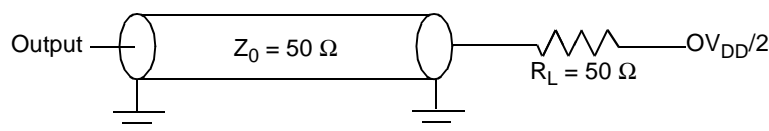
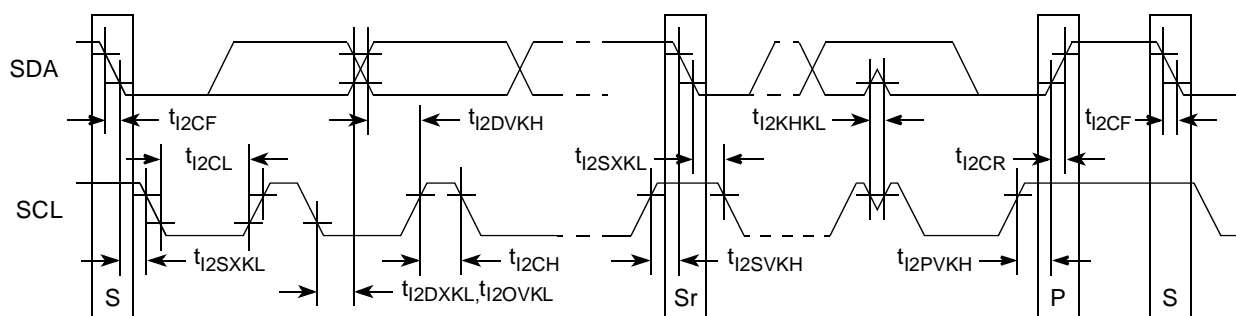

Figure 17. I²C Bus AC Timing Diagram

4.7 PIC Serial Interrupt Mode AC Timing Specifications

Table 14 provides the PIC serial interrupt mode AC timing specifications for the MPC8245 at recommended operating conditions (see Table 2) with $G_{V_{DD}} = 3.3 \text{ V} \pm 5\%$ and $L_{V_{DD}} = 3.3 \text{ V} \pm 0.3 \text{ V}$.

Table 14. PIC Serial Interrupt Mode AC Timing Specifications

Num	Characteristic	Min	Max	Unit	Notes
1	S_CLK frequency	1/14 SDRAM_SYNC_IN	1/2 SDRAM_SYNC_IN	MHz	1
2	S_CLK duty cycle	40	60	%	—
3	S_CLK output valid time	—	6	ns	—
4	Output hold time	0	—	ns	—
5	$\overline{\text{S_FRAME}}$, S_RST output valid time	—	1 <i>sys_logic_clk</i> period + 6	ns	2
6	S_INT input setup time to S_CLK	1 <i>sys_logic_clk</i> period + 2	—	ns	2
7	S_INT inputs invalid (hold time) to S_CLK	—	0	ns	2

Notes:

- See the *MPC8245 Integrated Processor Reference Manual* for a description of the PIC interrupt control register (ICR) and S_CLK frequency programming.
- S_RST, S_FRAME, and S_INT shown in Figure 18 and Figure 19, depict timing relationships to *sys_logic_clk* and S_CLK and do not describe functional relationships between S_RST, S_FRAME, and S_INT. The *MPC8245 Integrated Processor Reference Manual* describes the functional relationships between these signals.
- The *sys_logic_clk* waveform is the clocking signal of the internal peripheral logic from the output of the peripheral logic PLL; *sys_logic_clk* is the same as SDRAM_SYNC_IN when the SDRAM_SYNC_OUT to SDRAM_SYNC_IN feedback loop is implemented and the DLL is locked. See the *MPC8245 Integrated Processor Reference Manual* for a complete clocking description.

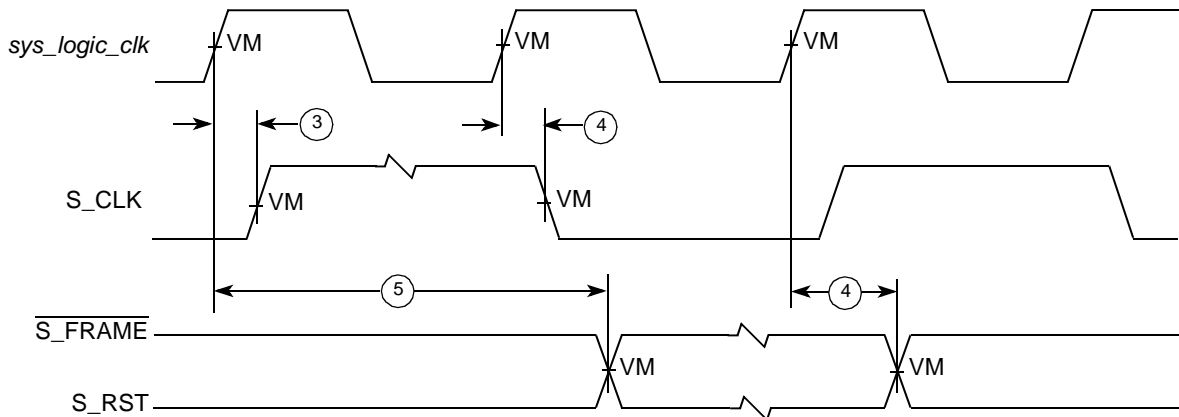

Figure 18. PIC Serial Interrupt Mode Output Timing Diagram

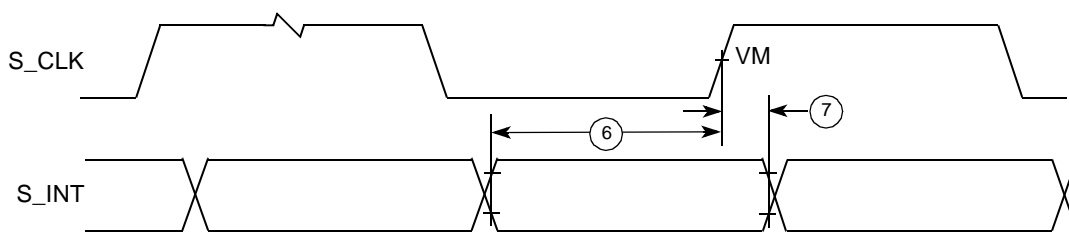

Figure 19. PIC Serial Interrupt Mode Input Timing Diagram

4.8 IEEE 1149.1 (JTAG) AC Timing Specifications

Table 15 provides the JTAG AC timing specifications for the MPC8245 while in the JTAG operating mode at recommended operating conditions (see Table 2) with $V_{DD} = 3.3 \text{ V} \pm 0.3 \text{ V}$. Timings are independent of the system clock (PCI_SYNC_IN).

Table 15. JTAG AC Timing Specification (Independent of PCI_SYNC_IN)

Num	Characteristic	Min	Max	Unit	Notes
	TCK frequency of operation	0	25	MHz	
1	TCK cycle time	40	—	ns	
2	TCK clock pulse width measured at 1.5 V	20	—	ns	
3	TCK rise and fall times	0	3	ns	
4	$\overline{\text{TRST}}$ setup time to TCK falling edge	10	—	ns	1
5	$\overline{\text{TRST}}$ assert time	10	—	ns	
6	Input data setup time	5	—	ns	2
7	Input data hold time	15	—	ns	2
8	TCK to output data valid	0	30	ns	3
9	TCK to output high impedance	0	30	ns	3
10	TMS, TDI data setup time	5	—	ns	

Table 15. JTAG AC Timing Specification (Independent of PCI_SYNC_IN) (continued)

Num	Characteristic	Min	Max	Unit	Notes
11	TMS, TDI data hold time	15	—	ns	
12	TCK to TDO data valid	0	15	ns	
13	TCK to TDO high impedance	0	15	ns	

Notes:

1. $\overline{\text{TRST}}$ is an asynchronous signal. The setup time is for test purposes only.
2. Nontest (other than TDI and TMS) signal input timing with respect to TCK.
3. Nontest (other than TDO) signal output timing with respect to TCK.

Figure 20 through Figure 23 show the different timing diagrams.

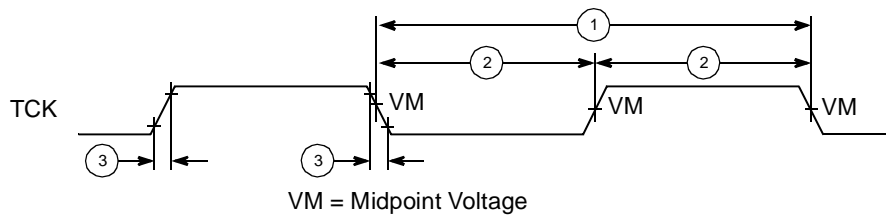

Figure 20. JTAG Clock Input Timing Diagram

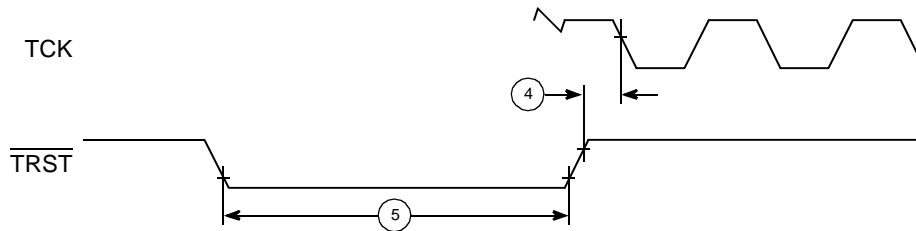

Figure 21. JTAG $\overline{\text{TRST}}$ Timing Diagram

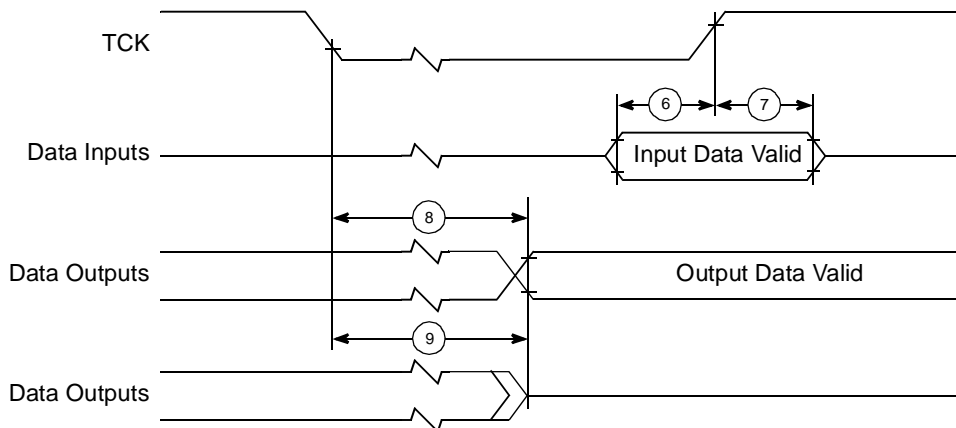

Figure 22. JTAG Boundary Scan Timing Diagram

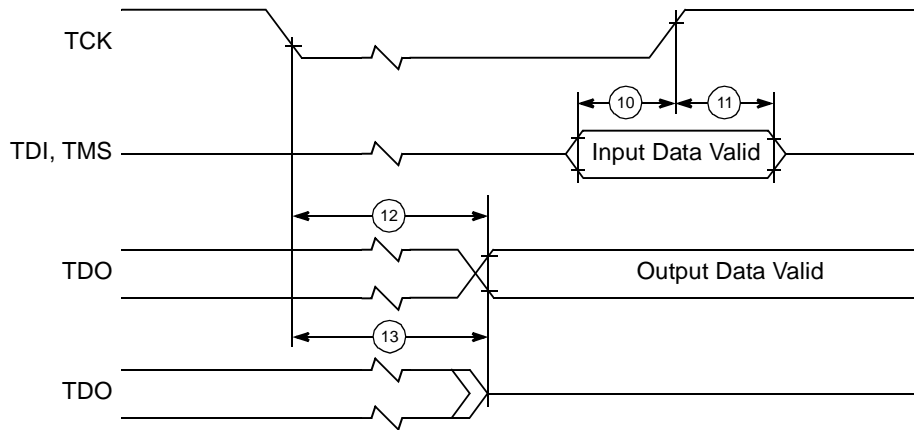

Figure 23. Test Access Port Timing Diagram

5 Package Description

This section details package parameters, pin assignments, and dimensions.

5.1 Package Parameters

The MPC8245 uses a 35 mm × 35 mm, cavity-up, 352-pin tape ball grid array (TBGA) package. The package parameters are as follows.

Package Outline	35 mm × 35 mm
Interconnects	352
Pitch	1.27 mm
Solder Balls	ZU (TBGA package)—62 Sn/36 Pb/2 Ag VV (Lead-free version of package)—95.5 Sn/4.0 Ag/0.5 Cu
Solder Ball Diameter	0.75 mm
Maximum Module Height	1.65 mm
Co-Planarity Specification	0.15 mm
Maximum Force	6.0 lbs. total, uniformly distributed over package (8 grams/ball)

5.2 Pin Assignments and Package Dimensions

Figure 24 shows the top surface, side profile, and pinout of the MPC8245, 352 TBGA package.

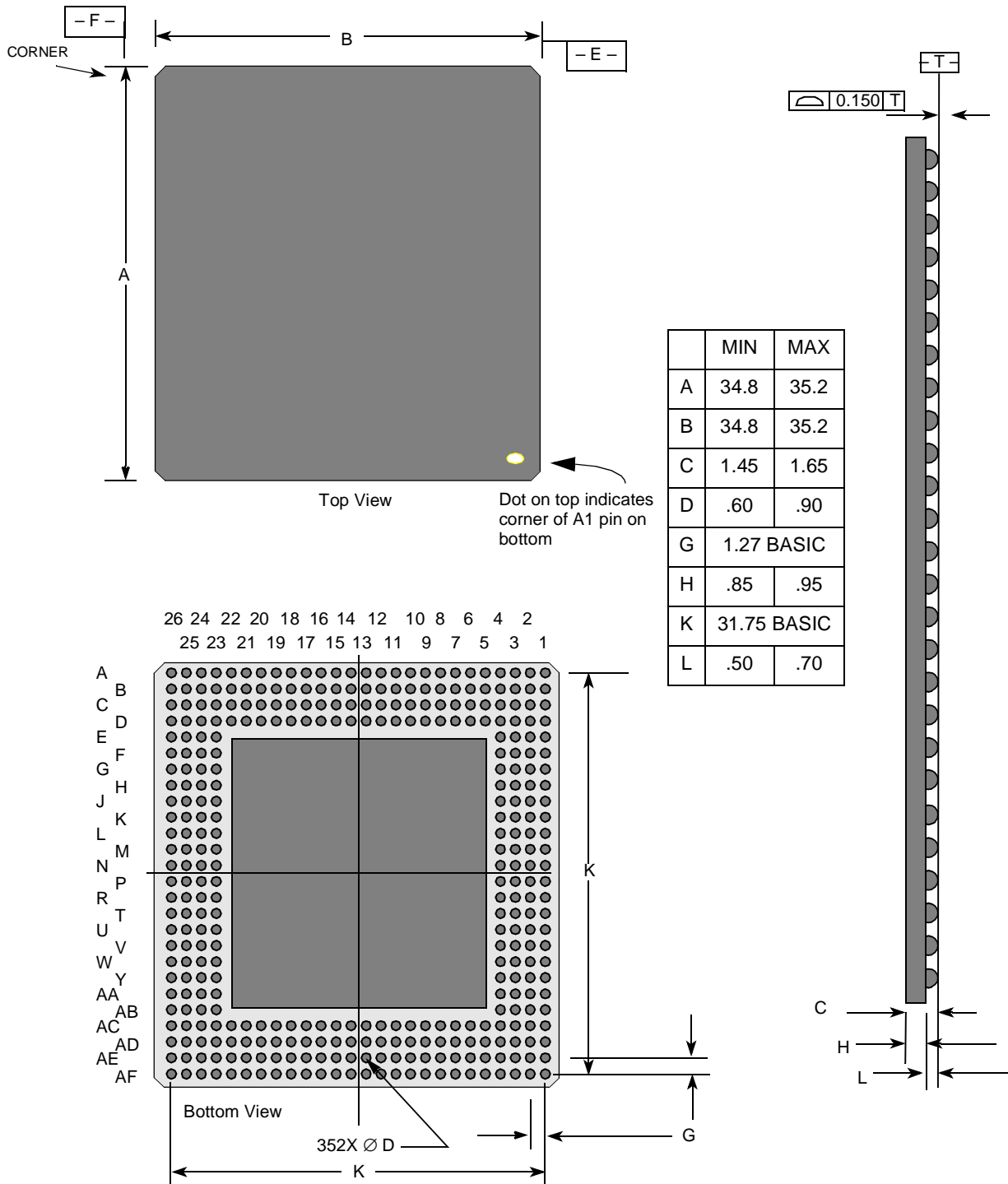

Notes:

1. Drawing not to scale.
2. All measurements are in millimeters (mm).

Figure 24. MPC8245 Package Dimensions and Pinout Assignments

5.3 Pinout Listings

Table 16 provides the pinout listing for the MPC8245, 352 TBGA package.

Table 16. MPC8245 Pinout Listing

Name	Pin Numbers	Type	Power Supply	Output Driver Type	Notes
PCI Interface Signals					
$\overline{C/BE}[3:0]$	P25 K23 F23 A25	I/O	OV_{DD}	DRV_PCI	6, 15
\overline{DEVSEL}	H26	I/O	OV_{DD}	DRV_PCI	8, 15
\overline{FRAME}	J24	I/O	OV_{DD}	DRV_PCI	8, 15
\overline{IRDY}	K25	I/O	OV_{DD}	DRV_PCI	8, 15
\overline{LOCK}	J26	Input	OV_{DD}	—	8
AD[31:0]	V25 U25 U26 U24 U23 T25 T26 R25 R26 N26 N25 N23 M26 M25 L25 L26 F24 E26 E25 E23 D26 D25 C26 A26 B26 A24 B24 D19 B23 B22 D22 C22	I/O	OV_{DD}	DRV_PCI	6, 15
PAR	G25	I/O	OV_{DD}	DRV_PCI	15
$\overline{GNT}[3:0]$	W25 W24 W23 V26	Output	OV_{DD}	DRV_PCI	6, 15
$\overline{GNT4/DA5}$	W26	Output	OV_{DD}	DRV_PCI	7, 15, 14
$\overline{REQ}[3:0]$	Y25 AA26 AA25 AB26	Input	OV_{DD}	—	6, 12
$\overline{REQ4/DA4}$	Y26	I/O	OV_{DD}	—	12, 14
\overline{PERR}	G26	I/O	OV_{DD}	DRV_PCI	8, 15, 18
\overline{SERR}	F26	I/O	OV_{DD}	DRV_PCI	8, 15, 16
\overline{STOP}	H25	I/O	OV_{DD}	DRV_PCI	8, 15
\overline{TRDY}	K26	I/O	OV_{DD}	DRV_PCI	8, 15
\overline{INTA}	AC26	Output	OV_{DD}	DRV_PCI	10, 15, 16
IDSEL	P26	Input	OV_{DD}	—	
Memory Interface Signals					
MDL[0:31]	AD17 AE17 AE15 AF15 AC14 AE13 AF13 AF12 AF11 AF10 AF9 AD8 AF8 AF7 AF6 AE5 B1 A1 A3 A4 A5 A6 A7 D7 A8 B8 A10 D10 A12 B11 B12 A14	I/O	GV_{DD}	DRV_STD_MEM	5, 6
MDH[0:31]	AC17 AF16 AE16 AE14 AF14 AC13 AE12 AE11 AE10 AE9 AE8 AC7 AE7 AE6 AF5 AC5 E4 A2 B3 D4 B4 B5 D6 C6 B7 C9 A9 B10 A11 A13 B13 A15	I/O	GV_{DD}	DRV_STD_MEM	6

Table 16. MPC8245 Pinout Listing (continued)

Name	Pin Numbers	Type	Power Supply	Output Driver Type	Notes
DQM[0:7]	AB1 AB2 K3 K2 AC1 AC2 K1 J1	Output	GV_{DD}	DRV_MEM_CTRL	6
\overline{CS} [0:7]	Y4 AA3 AA4 AC4 M2 L2 M1 L1	Output	GV_{DD}	DRV_MEM_CTRL	6
\overline{FOE}	H1	I/O	GV_{DD}	DRV_MEM_CTRL	3, 4
$\overline{RCS0}$	N4	Output	GV_{DD}	DRV_MEM_CTRL	3, 4
$\overline{RCS1}$	N2	Output	GV_{DD}	DRV_MEM_CTRL	
$\overline{RCS2}$ /TRIG_IN	AF20	I/O	OV_{DD}	6 ohms	10, 14
$\overline{RCS3}$ /TRIG_OUT	AC18	Output	GV_{DD}	DRV_MEM_CTRL	14
SDMA[1:0]	W1 W2	I/O	GV_{DD}	DRV_MEM_CTRL	3, 4, 6
SDMA[11:2]	N1 R1 R2 T1 T2 U4 U2 U1 V1 V3	Output	GV_{DD}	DRV_MEM_CTRL	6
\overline{DRDY}	B20	Input	OV_{DD}	—	9, 10
SDMA12/ \overline{SRESET}	B16	I/O	GV_{DD}	DRV_MEM_CTRL	10, 14
SDMA13/TBEN	B14	I/O	GV_{DD}	DRV_MEM_CTRL	10, 14
SDMA14/ CHKSTOP_IN	D14	I/O	GV_{DD}	DRV_MEM_CTRL	10, 14
SDBA1	P1	Output	GV_{DD}	DRV_MEM_CTRL	
SDBA0	P2	Output	GV_{DD}	DRV_MEM_CTRL	
PAR[0:7]	AF3 AE3 G4 E2 AE4 AF4 D2 C2	I/O	GV_{DD}	DRV_STD_MEM	6
\overline{SDRAS}	AD1	Output	GV_{DD}	DRV_MEM_CTRL	3
\overline{SDCAS}	AD2	Output	GV_{DD}	DRV_MEM_CTRL	3
CKE	H2	Output	GV_{DD}	DRV_MEM_CTRL	3, 4
\overline{WE}	AA1	Output	GV_{DD}	DRV_MEM_CTRL	
\overline{AS}	Y1	Output	GV_{DD}	DRV_MEM_CTRL	3, 4
PIC Control Signals					
IRQ0/S_INT	C19	Input	OV_{DD}	—	
IRQ1/S_CLK	B21	I/O	OV_{DD}	DRV_PCI	
IRQ2/S_RST	AC22	I/O	OV_{DD}	DRV_PCI	
IRQ3/ $\overline{S_FRAME}$	AE24	I/O	OV_{DD}	DRV_PCI	
IRQ4/ $\overline{L_INT}$	A23	I/O	OV_{DD}	DRV_PCI	
I²C Control Signals					
SDA	AE20	I/O	OV_{DD}	DRV_STD_MEM	10, 16
SCL	AF21	I/O	OV_{DD}	DRV_STD_MEM	10, 16

Table 16. MPC8245 Pinout Listing (continued)

Name	Pin Numbers	Type	Power Supply	Output Driver Type	Notes
DUART Control Signals					
SOUT1/PCI_CLK0	AC25	Output	GV _{DD}	DRV_MEM_CTRL	13, 14
SIN1/PCI_CLK1	AB25	I/O	GV _{DD}	DRV_MEM_CTRL	13, 14, 26
SOUT2/RTS1/ PCI_CLK2	AE26	Output	GV _{DD}	DRV_MEM_CTRL	13, 14
SIN2/CTS1/ PCI_CLK3	AF25	I	GV _{DD}	DRV_MEM_CTRL	13, 14, 26
Clock-Out Signals					
PCI_CLK0/SOUT1	AC25	Output	GV _{DD}	DRV_PCI_CLK	13, 14
PCI_CLK1/SIN1	AB25	Output	GV _{DD}	DRV_PCI_CLK	13, 14, 26
PCI_CLK2/RTS1/ SOUT2	AE26	Output	GV _{DD}	DRV_PCI_CLK	13, 14
PCI_CLK3/CTS1/ SIN2	AF25	Output	GV _{DD}	DRV_PCI_CLK	13, 14, 26
PCI_CLK4/DA3	AF26	Output	GV _{DD}	DRV_PCI_CLK	13, 14
PCI_SYNC_OUT	AD25	Output	GV _{DD}	DRV_PCI_CLK	
PCI_SYNC_IN	AB23	Input	GV _{DD}	—	
SDRAM_CLK [0:3]	D1 G1 G2 E1	Output	GV _{DD}	DRV_MEM_CTRL or DRV_MEM_CLK	6, 21
SDRAM_SYNC_OUT	C1	Output	GV _{DD}	DRV_MEM_CTRL or DRV_MEM_CLK	21
SDRAM_SYNC_IN	H3	Input	GV _{DD}	—	
CKO/DA1	B15	Output	OV _{DD}	DRV_STD_MEM	14
OSC_IN	AD21	Input	OV _{DD}	—	19
Miscellaneous Signals					
HRST_CTRL	A20	Input	OV _{DD}	—	27
HRST_CPU	A19	Input	OV _{DD}	—	27
MCP	A17	Output	OV _{DD}	DRV_STD_MEM	3, 4, 17
NMI	D16	Input	OV _{DD}	—	
SMI	A18	Input	OV _{DD}	—	10
SRESET/SDMA12	B16	I/O	GV _{DD}	DRV_MEM_CTRL	10, 14
TBEN/SDMA13	B14	I/O	GV _{DD}	DRV_MEM_CTRL	10, 14

Table 16. MPC8245 Pinout Listing (continued)

Name	Pin Numbers	Type	Power Supply	Output Driver Type	Notes
$\overline{QACK/DA0}$	F2	Output	OV_{DD}	DRV_STD_MEM	4, 14, 25
$\overline{CHKSTOP_IN/SDMA14}$	D14	I/O	GV_{DD}	DRV_MEM_CTRL	10, 14
$\overline{TRIG_IN/RCS2}$	AF20	I/O	OV_{DD}	—	10, 14
$\overline{TRIG_OUT/RCS3}$	AC18	Output	GV_{DD}	DRV_MEM_CTRL	14
MAA[0:2]	AF2 AF1 AE1	Output	GV_{DD}	DRV_STD_MEM	3, 4, 6
\overline{MIV}	A16	Output	OV_{DD}	—	24
PMAA[0:1]	AD18 AF18	Output	OV_{DD}	DRV_STD_MEM	3, 4, 6, 15
PMAA[2]	AE19	Output	OV_{DD}	DRV_STD_MEM	4, 6, 15
Test/Configuration Signals					
PLL_CFG[0:4]/DA[10:6]	A22 B19 A21 B18 B17	I/O	OV_{DD}	DRV_STD_MEM	6, 14, 20
$\overline{TEST0}$	AD22	Input	OV_{DD}	—	1, 9
RTC	Y2	Input	GV_{DD}	—	11
TCK	AF22	Input	OV_{DD}	—	9, 12
TDI	AF23	Input	OV_{DD}	—	9, 12
TDO	AC21	Output	OV_{DD}	—	24
TMS	AE22	Input	OV_{DD}	—	9, 12
\overline{TRST}	AE23	Input	OV_{DD}	—	9, 12
Power and Ground Signals					
GND	AA2 AA23 AC12 AC15 AC24 AC3 AC6 AC9 AD11 AD14 AD16 AD19 AD23 AD4 AE18 AE2 AE21 AE25 B2 B25 B6 B9 C11 C13 C16 C23 C4 C8 D12 D15 D18 D21 D24 D3 F25 F4 H24 J25 J4 L24 L3 M23 M4 N24 P3 R23 R4 T24 T3 V2 V23 W3	Ground	—	—	
LV_{DD}	AC20 AC23 D20 D23 G23 P23 Y23	Reference voltage 3.3 V, 5.0 V	LV_{DD}	—	
GV_{DD}	AB3 AB4 AC10 AC11 AC8 AD10 AD13 AD15 AD3 AD5 AD7 C10 C12 C3 C5 C7 D13 D5 D9 E3 G3 H4 K4 L4 N3 P4 R3 U3 V4 Y3	Power for memory drivers 3.3 V	GV_{DD}	—	
OV_{DD}	AB24 AD20 AD24 C14 C20 C24 E24 G24 J23 K24 M24 P24 T23 Y24	PCI/Std 3.3 V	OV_{DD}	—	

Table 16. MPC8245 Pinout Listing (continued)

Name	Pin Numbers	Type	Power Supply	Output Driver Type	Notes
V _{DD}	AA24 AC16 AC19 AD12 AD6 AD9 C15 C18 C21 D11 D8 F3 H23 J3 L23 M3 R24 T4 V24 W4	Power for core 1.8/2.0 V	V _{DD}	—	22
No Connect	D17	—	—	—	23
AV _{DD}	C17	Power for PLL (CPU core logic) 1.8/2.0 V	AV _{DD}	—	22
AV _{DD2}	AF24	Power for PLL (peripheral logic) 1.8/2.0 V	AV _{DD2}	—	22
Debug/Manufacturing Pins					
DA0/QACK	F2	Output	OV _{DD}	DRV_STD_MEM	4, 10, 25
DA1/CKO	B15	Output	OV _{DD}	DRV_STD_MEM	14
DA2	C25	Output	OV _{DD}	DRV_PCI	2
DA3/PCI_CLK4	AF26	Output	GV _{DD}	DRV_PCI_CLK	14
DA4/REQ4	Y26	I/O	OV _{DD}	—	12, 14
DA5/GNT4	W26	Output	OV _{DD}	DRV_PCI	7, 15, 14
DA[10:6]/ PLL_CFG[0:4]	A22 B19 A21 B18 B17	I/O	OV _{DD}	DRV_STD_MEM	6, 14, 20
DA[11]	AD26	Output	OV _{DD}	DRV_PCI	2
DA[12:13]	AF17 AF19	Output	OV _{DD}	DRV_STD_MEM	2, 6

Table 16. MPC8245 Pinout Listing (continued)

Name	Pin Numbers	Type	Power Supply	Output Driver Type	Notes
DA[14:15]	F1 J2	Output	GV _{DD}	DRV_MEM_CTRL	2, 6

Notes:

- Place a pull-up resistor of 120 Ω or less on the $\overline{\text{TEST0}}$ pin.
- Treat these pins as no connects (NC) unless debug address functionality is used.
- This pin has an internal pull-up resistor that is enabled only in the reset state. The value of the internal pull-up resistor is not guaranteed but is sufficient to ensure that a logic 1 is read into configuration bits during reset if the signal is left unterminated.
- This pin is a reset configuration pin.
- DL[0] is a reset configuration pin with an internal pull-up resistor that is enabled only in the reset state. The value of the internal pull-up resistor is not guaranteed but is sufficient to ensure that a logic 1 is read into configuration bits during reset.
- Multi-pin signals such as AD[31:0] and MDL[0:31] have their physical package pin numbers listed in an order corresponding to the signal names. Example: AD0 is on pin C22, AD1 is on pin D22, ..., AD31 is on pin V25.
- $\overline{\text{GNT4}}$ is a reset configuration pin with an internal pull-up resistor that is enabled only in the reset state.
- A weak pull-up resistor (2–10 k Ω) should be placed on this PCI control pin to LV_{DD}.
- V_{IH} and V_{IL} for these signals are the same as the PCI V_{IH} and V_{IL} entries in [Table 3](#).
- A weak pull-up resistor (2–10 k Ω) should be placed on this pin to OV_{DD}.
- A weak pull-up resistor (2–10 k Ω) should be placed on this pin to GV_{DD}.
- This pin has an internal pull-up resistor that is enabled at all times. The value of the internal pull-up resistor is not guaranteed but is sufficient to prevent unused inputs from floating.
- An external PCI clocking source or fan-out buffer may be required for the MPC8245 DUART functionality since PCI_CLK[0:3] are not available in DUART mode. Only PCI_CLK4 is available in DUART mode.
- This pin is a multiplexed signal and appears more than once in this table.
- This pin is affected by the programmable PCI_HOLD_DEL parameter.
- This pin is an open-drain signal.
- This pin can be programmed as driven (default) or as open-drain (in MIOCR 1).
- This pin is a sustained three-state pin as defined by the *PCI Local Bus Specification*.
- OSC_IN uses the 3.3-V PCI interface driver, which is 5-V tolerant. See [Table 2](#) for details.
- PLL_CFG signals must be driven on reset and must be held for at least 25 clock cycles after the negation of $\overline{\text{HRST_CTRL}}$ and $\overline{\text{HRST_CPU}}$ in order to be latched.
- SDRAM_CLK[0:3] and SDRAM_SYNC_OUT signals use DRV_MEM_CTRL for chip Rev 1.1 (A). These signals use DRV_MEM_CLK for chip Rev 1.2 (B).
- The 266- and 300-MHz part offerings can run at a source voltage of 1.8 \pm 100 mV or 2.0 \pm 100 mV. Source voltage should be 2.0 \pm 100 mV for 333- and 350-MHz parts.
- This pin is LAVDD on the MPC8240. It is an NC on the MPC8245, which should not pose a problem when an MPC8240 is replaced with an MPC8245.
- The driver capability of this pin is hardwired to 40 Ω and cannot be changed.
- A weak pull-up resistor (2–10 k Ω) should be placed on this pin to OV_{DD} so that a 1 can be detected at reset if an external memory clock is not used and PLL[0:4] does not select a half-clock frequency ratio.
- Typically, the serial port has sufficient drivers in the RS232 transceiver to drive the $\overline{\text{CTS}}$ pin actively as an input. No pullups are needed in this case.
- $\overline{\text{HRST_CPU}}/\overline{\text{HRST_CTRL}}$ must transition from a logic 0 to a logic 1 in less than one SDRAM_SYNC_IN clock cycle for the device to be in the nonreset state

6 PLL Configurations

The internal PLLs are configured by the PLL_CFG[0:4] signals. For a given PCI_SYNC_IN (PCI bus) frequency, the PLL configuration signals set both the peripheral logic/memory bus PLL (VCO) frequency of operation for the PCI-to-memory frequency multiplying and the MPC603e CPU PLL (VCO) frequency of operation for memory-to-CPU frequency multiplying. The PLL configurations are shown in [Table 17](#) and [Table 18](#).

Table 17. PLL Configurations (266- and 300-MHz Parts)

Ref. No.	PLL_CFG [0:4] ^{10,13}	266-MHz Part ⁹			300-MHz Part ⁹			Multipliers	
		PCI Clock Input (PCI_SYNC_IN) Range ¹ (MHz)	Periph Logic/MemBus Clock Range (MHz)	CPU Clock Range (MHz)	PCI Clock Input (PCI_SYNC_IN) Range ¹ (MHz)	Periph Logic/MemBus Clock Range (MHz)	CPU Clock Range (MHz)	PCI-to-Mem (Mem VCO)	Mem-to-CPU (CPU VCO)
0	00000 ¹²	25–35 ⁵	75–105	188–263	25–40 ^{5,7}	75–120	188–300	3 (2)	2.5 (2)
1	00001 ¹²	25–29 ⁵	75–88	225–264	25–33 ⁵	75–99	225–297	3 (2)	3 (2)
2	00010 ¹¹	50 ¹⁸ –59 ^{5,7}	50–59	225–266	50 ¹⁸ –66 ¹	50–66	225–297	1 (4)	4.5 (2)
3	00011 ^{11,14}	50 ¹⁷ –66 ¹	50–66	100–133	50 ¹⁷ –66 ¹	50–66	100–133	1 (Bypass)	2 (4)
4	00100 ¹²	25–46 ⁴	50–92	100–184	25–46 ⁴	50–92	100–184	2 (4)	2 (4)
6	00110 ¹⁵	Bypass			Bypass			Bypass	
7 Rev B	00111 ¹⁴	60 ⁶ –66 ¹	60–66	180–198	60 ⁶ –66 ¹	60–66	180–198	1 (Bypass)	3 (2)
7 Rev D	00111 ¹⁴	Not available							
8	01000 ¹²	60 ⁶ –66 ¹	60–66	180–198	60 ⁶ –66 ¹	60–66	180–198	1 (4)	3 (2)
9	01001 ¹²	45 ⁶ –66 ¹	90–132	180–264	45 ⁶ –66 ¹	90–132	180–264	2 (2)	2 (2)
A	01010 ¹²	25–29 ⁵	50–58	225–261	25–33 ⁵	50–66	225–297	2 (4)	4.5 (2)
B	01011 ¹²	45 ³ –59 ⁵	68–88	204–264	45 ³ –66 ¹	68–99	204–297	1.5 (2)	3 (2)
C	01100 ¹²	36 ⁶ –46 ⁴	72–92	180–230	36 ⁶ –46 ⁴	72–92	180–230	2 (4)	2.5 (2)
D	01101 ¹²	45 ³ –50 ⁵	68–75	238–263	45 ³ –57 ⁵	68–85	238–298	1.5 (2)	3.5 (2)
E	01110 ¹²	30 ⁶ –44 ⁵	60–88	180–264	30 ⁶ –46 ⁴	60–92	180–276	2 (4)	3 (2)
F	01111 ¹²	25 ⁵	75	263	25–28 ⁵	75–85	263–298	3 (2)	3.5 (2)
10	10000 ¹²	30 ⁶ –44 ^{2,5}	90–132	180–264	30 ⁶ –44 ²	90–132	180–264	3 (2)	2 (2)
11	10001 ¹²	25–26 ^{5,7}	100–106	250–266	25–29 ²	100–116	250–290	4 (2)	2.5 (2)
12	10010 ¹²	60 ⁶ –66 ¹	90–99	180–198	60 ⁶ –66 ¹	90–99	180–198	1.5 (2)	2 (2)

Table 17. PLL Configurations (266- and 300-MHz Parts) (continued)

Ref. No.	PLL_CFG [0:4] ^{10,13}	266-MHz Part ⁹			300-MHz Part ⁹			Multipliers	
		PCI Clock Input (PCI_ SYNC_IN) Range ¹ (MHz)	Periph Logic/ MemBus Clock Range (MHz)	CPU Clock Range (MHz)	PCI Clock Input (PCI_ SYNC_IN) Range ¹ (MHz)	Periph Logic/ MemBus Clock Range (MHz)	CPU Clock Range (MHz)	PCI-to- Mem (Mem VCO)	Mem-to- CPU (CPU VCO)
13	10011 ¹²	Not available			25 ^{2,7}	100	300	4 (2)	3 (2)
14	10100 ¹²	26 ⁶ –38 ⁵	52–76	182–266	26 ⁶ –42 ⁵	52–84	182–294	2 (4)	3.5 (2)
15	10101 ¹²	Not available			27 ³ –30 ^{5,7}	68–75	272–300	2.5 (2)	4 (2)
16	10110 ¹²	25–33 ⁵	50–66	200–264	25–37 ⁵	50–74	200–296	2 (4)	4 (2)
17	10111 ¹²	25–33 ⁵	100–132	200–264	25–33 ²	100–132	200–264	4 (2)	2 (2)
18	11000 ¹²	27 ³ –35 ⁵	68–88	204–264	27 ³ –40 ^{5,7}	68–100	204–300	2.5 (2)	3 (2)
19	11001 ¹²	36 ⁶ –53 ⁵	72–106	180–265	36 ⁶ –59 ²	72–118	180–295	2 (2)	2.5 (2)
1A	11010 ¹²	50 ¹⁸ –66 ¹	50–66	200–264	50 ¹⁸ –66 ¹	50–66	200–264	1 (4)	4 (2)
1B	11011 ¹²	34 ³ –44 ⁵	68–88	204–264	34 ³ –50 ^{5,7}	68–100	204–300	2 (2)	3 (2)
1C	11100 ¹²	44 ³ –59 ⁵	66–88	198–264	44 ³ –66 ¹	66–99	198–297	1.5 (2)	3 (2)
1D	11101 ¹²	48 ⁶ –66 ¹	72–99	180–248	48 ⁶ –66 ¹	72–99	180–248	1.5 (2)	2.5 (2)
1E Rev B	11110 ⁸	Not usable			Not usable			Off	Off
1E Rev D	11110	33 ³ –38 ⁵	66–76	231–266	33 ³ –42 ⁵	66–84	231–294	2(2)	3.5(2)

Table 17. PLL Configurations (266- and 300-MHz Parts) (continued)

Ref. No.	PLL_CFG [0:4] ^{10,13}	266-MHz Part ⁹			300-MHz Part ⁹			Multipliers	
		PCI Clock Input (PCI_SYNC_IN) Range ¹ (MHz)	Periph Logic/MemBus Clock Range (MHz)	CPU Clock Range (MHz)	PCI Clock Input (PCI_SYNC_IN) Range ¹ (MHz)	Periph Logic/MemBus Clock Range (MHz)	CPU Clock Range (MHz)	PCI-to-Mem (Mem VCO)	Mem-to-CPU (CPU VCO)
1F	11111 ⁸	Not usable			Not usable			Off	Off

Notes:

1. Limited by the maximum PCI input frequency (66 MHz).
2. Limited by the maximum system memory interface operating frequency (100 MHz @ 300 MHz CPU).
3. Limited by the minimum memory VCO frequency (133 MHz).
4. Limited due to the maximum memory VCO frequency (372 MHz).
5. Limited by the maximum CPU operating frequency.
6. Limited by the minimum CPU VCO frequency (360 MHz).
7. Limited by the maximum CPU VCO frequency (maximum marked CPU speed X 2).
8. In clock-off mode, no clocking occurs inside the MPC8245, regardless of the PCI_SYNC_IN input.
9. Range values are rounded down to the nearest whole number (decimal place accuracy removed).
10. PLL_CFG[0:4] settings not listed are reserved.
11. Multiplier ratios for this PLL_CFG[0:4] setting differ from the MPC8240 and are not backward-compatible.
12. PCI_SYNC_IN range for this PLL_CFG[0:4] setting differs from or does not exist on the MPC8240 and may not be fully backward-compatible.
13. Bits 7–4 of register offset <0xE2> contain the PLL_CFG[0:4] setting value.
14. In PLL bypass mode, the PCI_SYNC_IN input signal clocks the internal processor directly, the peripheral logic PLL is disabled, and the bus mode is set for 1:1 (PCI:Mem) mode operation. This mode is for hardware modeling. The AC timing specifications in this document do not apply in PLL bypass mode.
15. In dual PLL bypass mode, the PCI_SYNC_IN input signal clocks the internal peripheral logic directly, the peripheral logic PLL is disabled, and the bus mode is set for 1:1 (PCI_SYNC_IN:Mem) mode operation. In this mode, the OSC_IN input signal clocks the internal processor directly in 1:1 (OSC_IN:CPU) mode operation, and the processor PLL is disabled. The PCI_SYNC_IN and OSC_IN input clocks must be externally synchronized. This mode is for hardware modeling. The AC timing specifications in this document do not apply in dual PLL bypass mode.
16. Limited by the maximum system memory interface operating frequency (133 MHz @ 266 MHz CPU).
17. Limited by the minimum CPU operating frequency (100 MHz).
18. Limited by the minimum memory bus frequency (50 MHz).

Table 18. PLL Configurations (333- and 350-MHz Parts)

Ref	PLL_CFG[0:4] ^{10,13}	333 MHz Part ⁹			350 MHz Part ⁹			Multipliers	
		PCI Clock Input (PCI_SYNC_IN) Range ¹ (MHz)	Periph Logic/Mem Bus Clock Range (MHz)	CPU Clock Range (MHz)	PCI Clock Input (PCI_SYNC_IN) Range ¹ (MHz)	Periph Logic/Mem Bus Clock Range (MHz)	CPU Clock Range (MHz)	PCI-to-Mem (Mem VCO)	Mem-to-CPU (CPU VCO)
0	00000 ¹²	25–44 ¹⁶	75–132	188–330	25–44 ¹⁶	75–132	188–330	3 (2)	2.5 (2)
1	00001 ¹²	25–37 ^{5,7}	75–111	225–333	25–38 ⁵	75–114	225–342	3 (2)	3 (2)

Table 18. PLL Configurations (333- and 350-MHz Parts) (continued)

Ref	PLL_CFG[0:4] ^{10,13}	333 MHz Part ⁹			350 MHz Part ⁹			Multipliers	
		PCI Clock Input (PCI_SYNC_IN) Range ¹ (MHz)	Periph Logic/Mem Bus Clock Range (MHz)	CPU Clock Range (MHz)	PCI Clock Input (PCI_SYNC_IN) Range ¹ (MHz)	Periph Logic/Mem Bus Clock Range (MHz)	CPU Clock Range (MHz)	PCI-to-Mem (Mem VCO)	Mem-to-CPU (CPU VCO)
2	00010 ¹¹	50 ¹⁸ –66 ¹	50–66	225–297	50 ¹⁸ –66 ¹	50–66	225–297	1 (4)	4.5 (2)
3	00011 ^{11,14}	50 ¹⁷ –66 ¹	50–66	100–133	50 ¹⁷ –66 ¹	50–66	100–133	1 (Bypass)	2 (4)
4	00100 ¹²	25–46 ⁴	50–92	100–184	25–46 ⁴	50–92	100–184	2 (4)	2 (4)
6	00110 ¹⁵	Bypass			Bypass			Bypass	
7 Rev B	00111 ¹⁴	60 ⁶ –66 ¹	60–66	180–198	60 ⁶ –66 ¹	60–66	180–198	1 (Bypass)	3 (2)
7 Rev D	00111 ¹⁴	Not available			25	100	350	4(2)	3.5(2)
8	01000 ¹²	60 ⁶ –66 ¹	60–66	180–198	60 ⁶ –66 ¹	60–66	180–198	1 (4)	3 (2)
9	01001 ¹²	45 ⁶ –66 ¹	90–132	180–264	45 ⁶ –66 ¹	90–132	180–264	2 (2)	2 (2)
A	01010 ¹²	25–37 ^{5,7}	50–74	225–333	25–38 ⁵	50–76	225–342	2 (4)	4.5 (2)
B	01011 ¹²	45 ³ –66 ¹	68–99	204–297	45 ³ –66 ¹	68–99	204–297	1.5 (2)	3 (2)
C	01100 ¹²	36 ⁶ –46 ⁴	72–92	180–230	36 ⁶ –46 ⁴	72–92	180–230	2 (4)	2.5 (2)
D	01101 ¹²	45 ³ –63 ^{5,7}	68–95	238–333	45 ³ –66 ¹	68–99	238–347	1.5 (2)	3.5 (2)
E	01110 ¹²	30 ⁶ –46 ⁴	60–92	180–276	30 ⁶ –46 ⁴	60–92	180–276	2 (4)	3 (2)
F	01111 ¹²	25–31 ⁵	75–93	263–326	25–33 ⁵	75–99	263–347	3 (2)	3.5 (2)
10	10000 ¹²	30 ⁶ –44 ²	90–132	180–264	30 ⁶ –44 ²	90–132	180–264	3 (2)	2 (2)
11	10001 ¹²	25–33 ^{2,16}	100–132	250–330	25–33 ^{2,16}	100–132	250–330	4 (2)	2.5 (2)
12	10010 ¹²	60 ⁶ –66 ¹	90–99	180–198	60 ⁶ –66 ¹	90–99	180–198	1.5 (2)	2 (2)
13	10011 ¹²	25–27 ⁵	100–108	300–324	25–29 ⁵	100–116	300–348	4 (2)	3 (2)
14	10100 ¹²	26 ⁶ –47 ⁴	52–94	182–329	26 ⁶ –47 ⁴	52–94	182–329	2 (4)	3.5 (2)
15	10101 ¹²	27 ³ –33 ⁵	68–83	272–332	27 ³ –34 ⁵	68–85	272–340	2.5 (2)	4 (2)
16	10110 ¹²	25–41 ⁵	50–82	200–328	25–43 ⁵	50–86	200–344	2 (4)	4 (2)
17	10111 ¹²	25–33 ²	100–132	200–264	25–33 ²	100–132	200–264	4 (2)	2 (2)
18	11000 ¹²	27 ³ –44 ⁵	68–110	204–330	27 ³ –46 ⁵	68–115	204–345	2.5 (2)	3 (2)
19	11001 ¹²	36 ⁶ –66 ¹	72–132	180–330	36 ⁶ –66 ¹	72–132	180–330	2 (2)	2.5 (2)
1A	11010 ¹²	50 ¹⁸ –66 ¹	50–66	200–264	50 ¹⁸ –66 ¹	50–66	200–264	1 (4)	4 (2)
1B	11011 ¹²	34 ³ –55 ⁵	68–110	204–330	34 ³ –58 ⁵	68–116	204–348	2 (2)	3 (2)
1C	11100 ¹²	44 ³ –66 ¹	66–99	198–297	44 ³ –66 ¹	66–99	198–297	1.5 (2)	3 (2)
1D	11101 ¹²	48 ⁶ –66 ¹	72–99	180–248	48 ⁶ –66 ¹	72–99	180–248	1.5 (2)	2.5(2)

Table 18. PLL Configurations (333- and 350-MHz Parts) (continued)

Ref	PLL_CFG[0:4] ^{10,13}	333 MHz Part ⁹			350 MHz Part ⁹			Multipliers	
		PCI Clock Input (PCI_SYNC_IN) Range ¹ (MHz)	Periph Logic/Mem Bus Clock Range (MHz)	CPU Clock Range (MHz)	PCI Clock Input (PCI_SYNC_IN) Range ¹ (MHz)	Periph Logic/Mem Bus Clock Range (MHz)	CPU Clock Range (MHz)	PCI-to-Mem (Mem VCO)	Mem-to-CPU (CPU VCO)
1E Rev B	11110 ⁸	Not usable			Not usable			Off	Off
1E Rev D	11110	33 ³ –47 ⁵	66–94	231–329	33 ³ –50 ^{2,5,7}	66–100	231–350	2(2)	3.5(2)
1F	11111 ⁸	Not usable			Not usable			Off	Off

Notes:

1. Limited by the maximum PCI input frequency (66 MHz).
2. Limited by the maximum system memory interface operating frequency (100 MHz @ 350 MHz CPU).
3. Limited by the minimum memory VCO frequency (132 MHz).
4. Limited due to the maximum memory VCO frequency (372 MHz).
5. Limited by the maximum CPU operating frequency.
6. Limited by the minimum CPU VCO frequency (360 MHz).
7. Limited by the maximum CPU VCO frequency (Maximum marked CPU speed X 2).
8. In clock-off mode, no clocking occurs inside the MPC8245, regardless of the PCI_SYNC_IN input.
9. Range values are rounded down to the nearest whole number (decimal place accuracy removed).
10. PLL_CFG[0:4] settings not listed are reserved.
11. Multiplier ratios for this PLL_CFG[0:4] setting differ from or do not exist on the MPC8240 and are not backward-compatible.
12. PCI_SYNC_IN range for this PLL_CFG[0:4] setting differs from the MPC8240 and may not be fully backward-compatible.
13. Bits 7–4 of register offset <0xE2> contain the PLL_CFG[0:4] setting value.
14. In PLL bypass mode, the PCI_SYNC_IN input signal clocks the internal processor directly, the peripheral logic PLL is disabled, and the bus mode is set for 1:1 (PCI:Mem) mode operation. This mode is for hardware modeling. The AC timing specifications in this document do not apply in PLL bypass mode.
15. In dual PLL bypass mode, the PCI_SYNC_IN input signal clocks the internal peripheral logic directly, the peripheral logic PLL is disabled, and the bus mode is set for 1:1 (PCI_SYNC_IN:Mem) mode operation. In this mode, the OSC_IN input signal clocks the internal processor directly in 1:1 (OSC_IN:CPU) mode operation, and the processor PLL is disabled. The PCI_SYNC_IN and OSC_IN input clocks must be externally synchronized. This mode is for hardware modeling. The AC timing specifications in this document do not apply in dual PLL bypass mode.
16. Limited by the maximum system memory interface operating frequency (133 MHz @ 333 MHz CPU).
17. Limited by the minimum CPU operating frequency (100 MHz).
18. Limited by the minimum memory bus frequency (50 MHz).

7 System Design

This section provides electrical and thermal design recommendations for successful application of the MPC8245.

7.1 PLL Power Supply Filtering

The AV_{DD} and AV_{DD2} power signals on the MPC8245 provide power to the peripheral logic/memory bus PLL and the MPC603e processor PLL. To ensure stability of the internal clocks, the power supplied to the AV_{DD} and AV_{DD2} input signals should be filtered of any noise in the 500-kHz to 10-MHz resonant frequency range of the PLLs. Two separate circuits similar to the one shown in Figure 25 using surface mount capacitors with minimum effective series inductance (ESL) is recommended for AV_{DD} and AV_{DD2} power signal pins. Consistent with the recommendations of Dr. Howard Johnson in *High Speed Digital Design: A Handbook of Black Magic* (Prentice Hall, 1993), using multiple small capacitors of equal value is recommended over using multiple values.

Place the circuits as closely as possible to the respective input signal pins to minimize noise coupled from nearby circuits. Routing from the capacitors to the input signal pins should be as direct as possible with minimal inductance of vias.

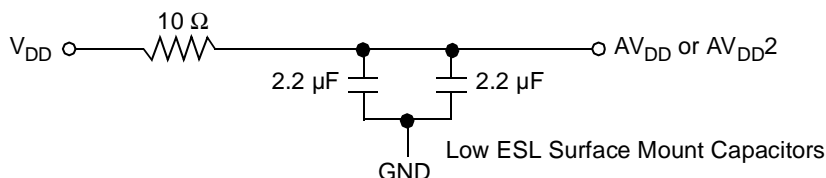

Figure 25. PLL Power Supply Filter Circuit

7.2 Decoupling Recommendations

Due to its dynamic power management feature, large address and data buses, and high operating frequencies, the MPC8245 can generate transient power surges and high frequency noise in its power supply, especially while driving large capacitive loads. This noise must be prevented from reaching other components in the MPC8245 system, and the MPC8245 itself requires a clean, tightly regulated source of power. Therefore, place at least one decoupling capacitor at each V_{DD} , OV_{DD} , GV_{DD} , and LV_{DD} pin. These decoupling capacitors should receive their power from dedicated power planes in the PCB, with short traces to minimize inductance. These capacitors should have a value of 0.1 μF . Only ceramic SMT (surface mount technology) capacitors should be used to minimize lead inductance, preferably 0508 or 0603, oriented such that connections are made along the length of the part.

In addition, several bulk storage capacitors should be distributed around the PCB, feeding the V_{DD} , OV_{DD} , GV_{DD} , and LV_{DD} planes, to enable quick recharging of the smaller chip capacitors. These bulk capacitors should have a low ESR (equivalent series resistance) rating to ensure the quick response time necessary. They should also be connected to the power and ground planes through two vias to minimize inductance. Suggested bulk capacitors: 100–330 μF (AVX TPS tantalum or Sanyo OSCON).

7.3 Connection Recommendations

To ensure reliable operation, connect unused inputs to an appropriate signal level. Tie unused active-low inputs to OV_{DD} . Connect unused active-high inputs tie to GND. All NC signals must remain unconnected.

Power and ground connections must be made to all external V_{DD} , OV_{DD} , GV_{DD} , LV_{DD} , and GND pins.

The PCI_SYNC_OUT signal is to be routed halfway out to the PCI devices and returned to the PCI_SYNC_IN input of the MPC8245.

The $SDRAM_SYNC_OUT$ signal is to be routed halfway out to the SDRAM devices and then returned to the $SDRAM_SYNC_IN$ input of the MPC8245. The trace length can be used to skew or adjust the timing window as needed. See the Tundra *Tsi107™ Design Guide* (AN1849) and Freescale application notes AN2164, *MPC8245/MPC8241 Memory Clock Design Guidelines: Part 1* and AN2746, *MPC8245/MPC8241 Memory Clock Design Guidelines: Part 2* for details. Note that there is an $SDRAM_SYNC_IN$ to PCI_SYNC_IN time requirement (refer to [Table 10](#) for the input AC timing specifications).

7.4 Pull-Up/Pull-Down Resistor Requirements

The data bus input receivers are normally turned off when no read operation is in progress; therefore, they do not require pull-up resistors on the bus. The data bus signals are: $MDH[0:31]$, $MDL[0:31]$, and $PAR[0:7]$.

If the 32-bit data bus mode is selected, the input receivers of the unused data and parity bits ($MDL[0:31]$ and $PAR[4:7]$) are disabled, and their outputs drive logic zeros when they would otherwise normally be driven. For this mode, these pins do not require pull-up resistors and should be left unconnected to minimize possible output switching.

The $\overline{TEST0}$ pin requires a pull-up resistor of 120 Ω or less connected to OV_{DD} .

RTC should have weak pull-up resistors (2–10 k Ω) connected to GV_{DD} .

The following signals should be pulled up to OV_{DD} with weak pull-up resistors (2–10 k Ω): SDA , SCL , \overline{SMI} , $\overline{SRESET}/SDMA12$, $\overline{TBEN}/SDMA13$, $\overline{CHKSTOP_IN}/SDMA14$, $\overline{TRIG_IN}/RCS2$, \overline{INTA} , $\overline{QACK}/DA0$ and \overline{DRDY} . Note that $\overline{QACK}/DA0$ should be left without a pull-up resistor only if an external clock is used because this signal enables internal clock flipping logic when it is low on reset, which is necessary when the $PLL[0:4]$ signals select a half-clock frequency ratio and an external PLL is used to drive the SDRAM device.

It is recommended that the following PCI control signals be pulled up to LV_{DD} (the clamping voltage) with weak pull-up resistors (2–10 k Ω): \overline{DEVSEL} , \overline{FRAME} , \overline{IRDY} , \overline{LOCK} , \overline{PERR} , \overline{SERR} , \overline{STOP} , and \overline{TRDY} . The resistor values may need to be adjusted stronger to reduce induced noise on specific board designs.

The following pins have internal pull-up resistors enabled at all times: $\overline{REQ}[3:0]$, $\overline{REQ4}/DA4$, TCK, TDI, TMS, and \overline{TRST} . See [Table 16](#).

The following pins have internal pull-up resistors enabled only while device is in the reset state: $\overline{GNT4}/DA5$, $MDL0$, \overline{FOE} , $\overline{RCS0}$, \overline{SDRAS} , \overline{SDCAS} , CKE , \overline{AS} , \overline{MCP} , $MAA[0:2]$, and $PMAA[0:2]$. See [Table 16](#).

The following pins are reset configuration pins: $\overline{\text{GNT4/DA5}}$, $\text{MDL}[0]$, $\overline{\text{FOE}}$, $\overline{\text{RCS0}}$, CKE , $\overline{\text{AS}}$, $\overline{\text{MCP}}$, $\overline{\text{QACK/DA0}}$, $\text{MAA}[0:2]$, $\text{PMAA}[0:2]$, $\text{SDMA}[1:0]$, $\text{MDH}[16:31]$, and $\text{PLL_CFG}[0:4]/\text{DA}[10:15]$. These pins are sampled during reset to configure the device. The $\text{PLL_CFG}[0:4]$ signals are sampled a few clocks after the negation of $\overline{\text{HRST_CPU}}$ and $\overline{\text{HRST_CTRL}}$.

Reset configuration pins should be tied to GND via 1-k Ω pull-down resistors to ensure a logic 0 level is read into the configuration bits during reset if the default logic 1 level is not desired.

Any other unused active low input pins should be tied to a logic-one level through weak pull-up resistors (2–10 k Ω) to the appropriate power supply listed in Table 16. Unused active high input pins should be tied to GND through weak pull-down resistors (2–10 k Ω).

7.5 PCI Reference Voltage— LV_{DD}

The MPC8245 PCI reference voltage (LV_{DD}) pins should be connected to a 3.3 ± 0.3 V power supply if interfacing the MPC8245 into a 3.3-V PCI bus system. Similarly, the LV_{DD} pins should be connected to a $5.0 \text{ V} \pm 5\%$ power supply if interfacing the MPC8245 into a 5-V PCI bus system. For either reference voltage, the MPC8245 always performs 3.3-V signaling as described in the *PCI Local Bus Specification* (Rev. 2.2). The MPC8245 tolerates 5-V signals when interfaced into a 5-V PCI bus system.

7.6 MPC8245 Compatibility with MPC8240

The MPC8245 AC timing specifications are backward-compatible with those of the MPC8240, except for the requirements of item 11 in Table 10. Timing adjustments are needed as specified for T_{OS} (SDRAM_SYNC_IN to *sys_logic_clk* offset) time requirements.

The MPC8245 does not support the SDRAM flow-through memory interface.

The nominal core V_{DD} power supply changes from 2.5 V on the MPC8240 to 1.8/2.0 V on the MPC8245. See Table 2.

For example, the MPC8245 $\text{PLL_CFG}[0:4]$ setting 0x02 (0b00010) has a different PCI-to-Mem and Mem-to-CPU multiplier ratio than the same setting on the MPC8240, so it is not backward-compatible. See Table 17.

Most of the MPC8240 $\text{PLL_CFG}[0:4]$ settings are subsets of the PCI_SYNC_IN input frequency range accepted by the MPC8245. However, the parts are not fully backward-compatible since the ranges of the two parts do not always match. Modes 0x8 and 0x18 of the MPC8245 are not compatible with settings 0x8 and 0x18 on the MPC8240. See Table 17 and Table 18.

Two reset configuration signals on the MPC8245 are not used as reset configuration signals on the MPC8240: SDMA0 and SDMA1.

The SDMA0 reset configuration pin selects between the MPC8245 DUART and the MPC8240 backward-compatible mode $\text{PCI_CLK}[0:4]$ functionality on these multiplexed signals. The default state (logic 1) of SDMA0 selects the MPC8240 backward-compatible mode of $\text{PCI_CLK}[0:4]$ functionality while a logic 0 state on the SDMA0 signal selects DUART functionality. In DUART mode, four of the five PCI clocks, $\text{PCI_CLK}[0:3]$, are not available.

The SDMA1 reset configuration pin selects between MPC8245 extended ROM functionality and MPC8240 backward-compatible functionality on the multiplexed signals: TBEN, $\overline{\text{CHKSTOP_IN}}$,

$\overline{\text{SRESET}}$, TRIG_IN, and TRIG_OUT. The default state (logic 1) of SDMA1 selects the MPC8240 backward-compatible mode functionality, while a logic 0 state on the SDMA1 signal selects extended ROM functionality. In extended ROM mode, the TBEN, $\overline{\text{CHKSTOP_IN}}$, $\overline{\text{SRESET}}$, TRIG_IN, and TRIG_OUT functionalities are not available.

The driver names and pin capability of the MPC8245 and the MPC8240 differ slightly. Refer to the drive capability table (for the ODCR register at 0x73) in the *MPC8240 Integrated Processor Hardware Specifications* and [Table 4](#).

The programmable PCI output valid and output hold feature controlled by bits in the power management configuration register 2 (PMCR2) <0x72> differs slightly in the MPC8245. For the MPC8240, three bits, PMCR2[6:4] = PCI_HOLD_DEL, are used to select 1 of 8 possible PCI output timing configurations. PMCR2[6:5] are software-controllable but are initially set by the reset configuration state of the $\overline{\text{MCP}}$ and CKE signals, respectively. Software can change PMCR2[4]. The default configuration for PMCR2[6:4] = 0b110 since the $\overline{\text{MCP}}$ and CKE signals have internal pull-up resistors, but this default configuration does not select 33- or 66-MHz PCI operation output timing parameters for the MPC8240. Software makes this selection. For the MPC8245, only two bits in the power management configuration register 2 (PMCR2), PMCR2[5:4] = PCI_HOLD_DEL, control the variable PCI output timing. PMCR2[5:4] are software controllable but are initially set by the inverted reset configuration state of the $\overline{\text{MCP}}$ and CKE signals, respectively. The default configuration for PMCR2[5:4] = 0b00 since the $\overline{\text{MCP}}$ and CKE signals have internal pull-up resistors and the values from these signals are inverted; this default configuration selects 66-MHz PCI operation output timing parameters. There are four programmable PCI output timing configurations on the MPC8245. See [Table 11](#).

Voltage sequencing requirements for the MPC8245 are similar to those for the MPC8240, with two exceptions in the MPC8245. In the MPC8245, the non-PCI input voltages (V_{in}) must not be greater than GV_{DD} or OV_{DD} by more than 0.6 V at all times, including during power-on reset (see Caution 5 in [Table 2](#)). Second, LV_{DD} must not exceed OV_{DD} by more than 3.0 V at any time, including during power-on reset (see Caution 10 in [Table 2](#)); the allowable separation between LV_{DD} and OV_{DD} is 3.6 V for the MPC8240.

There is no LAV_{DD} input voltage supply signal on the MPC8245 since the SDRAM clock delay-locked loop (DLL) has power supplied internally. Signal D17 should be treated as a NC for the MPC8245. Application note AN2128 highlights the differences between the MPC8240 and the MPC8245.

7.7 JTAG Configuration Signals

Boundary scan testing is enabled through the JTAG interface signals. The $\overline{\text{TRST}}$ signal is optional in the IEEE 1149.1 specification but is provided on all processors that implement the Power Architecture technology. While the TAP controller can be forced to the reset state using only the TCK and TMS signals, more reliable power-on reset performance can be obtained if the $\overline{\text{TRST}}$ signal is asserted during power-on reset. Because the JTAG interface is also used for accessing the common on-chip processor (COP) function, simply tying $\overline{\text{TRST}}$ to $\overline{\text{HRESET}}$ is not practical.

The COP function of these processors allows a remote computer system (typically, a PC with dedicated hardware and debugging software) to access and control the internal operations of the processor. The COP interface connects primarily through the JTAG, with additional status monitoring signals. The COP port must independently assert $\overline{\text{HRESET}}$ or $\overline{\text{TRST}}$ to control the processor. If the target system has independent

reset sources, such as voltage monitors, watchdog timers, power supply failures, or push-button switches, the COP reset signals must be merged into these signals with logic.

The arrangement shown in [Figure 26](#) allows the COP port to independently assert $\overline{\text{HRESET}}$ or $\overline{\text{TRST}}$, while ensuring that the target can drive $\overline{\text{HRESET}}$ as well. If the JTAG interface and COP header will not be used, $\overline{\text{TRST}}$ should be tied to $\overline{\text{HRESET}}$ through a 0- Ω isolation resistor so that it is asserted when the system reset signal ($\overline{\text{HRESET}}$) is asserted, ensuring that the JTAG scan chain is initialized during power-on. Although Freescale recommends that the COP header be designed into the system as shown in [Figure 26](#), if this is not possible, the isolation resistor will allow future access to $\overline{\text{TRST}}$ in the case where a JTAG interface may need to be wired onto the system in debug situations.

The COP interface has a standard header for connection to the target system based on the 0.025" square-post, 0.100" centered header assembly (often called a Berg header). Typically, pin 14 is removed as a connector key.

There is no standardized way to number the COP header shown in [Figure 26](#). Consequently, different emulator vendors number the pins differently. Some pins are numbered top-to-bottom and left-to-right while others use left-to-right then top-to-bottom and still others number the pins counter clockwise from pin 1 (as with an IC). Regardless of the numbering, the signal placement recommended in [Figure 26](#) is common to all known emulators.

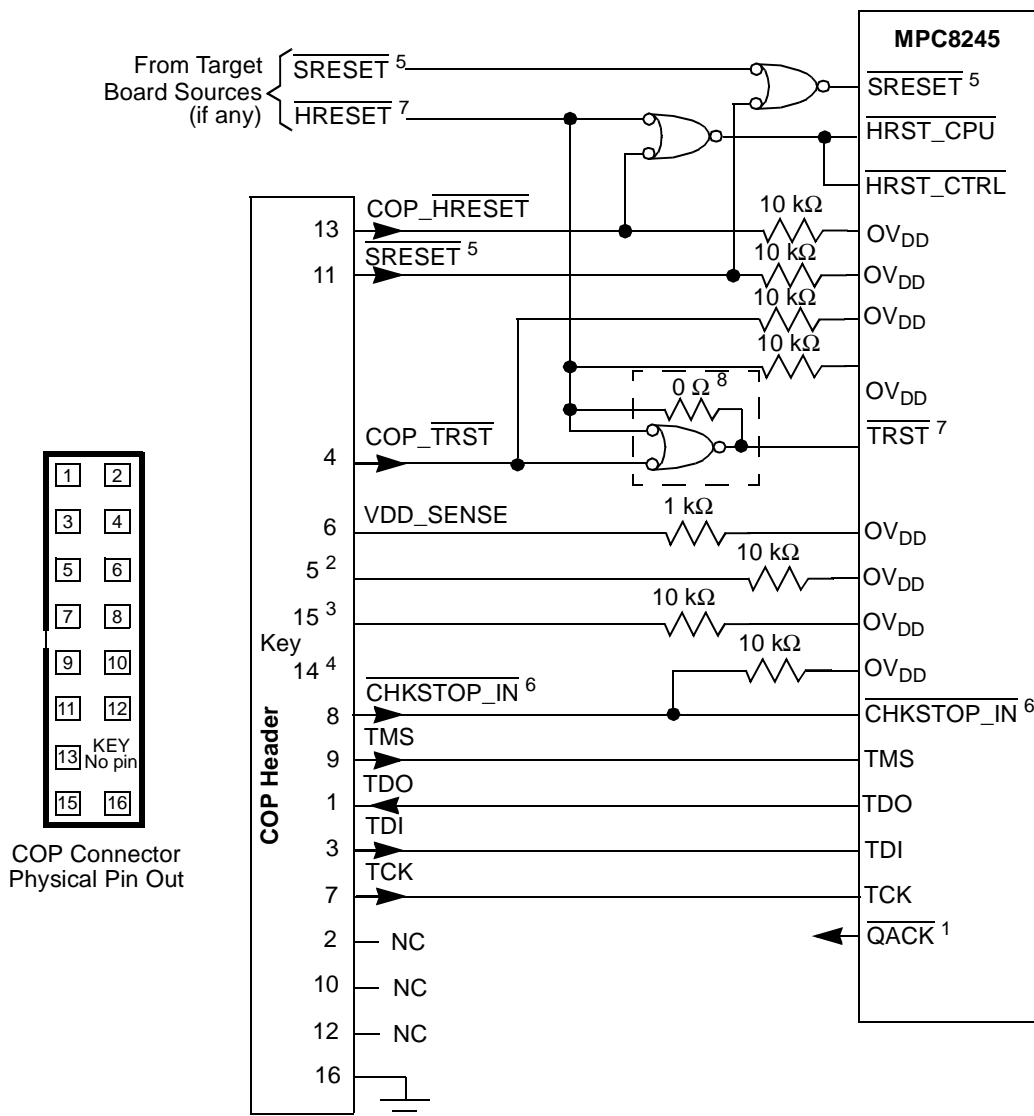

Figure 26. COP Connector Diagram

7.8 Thermal Management

This section provides thermal management information for the tape ball grid array (TBGA) package for air-cooled applications. Depending on the application environment and the operating frequency, heat sinks may be required to maintain junction temperature within specifications. Proper thermal control design primarily depends on the system-level design: the heat sink, airflow, and thermal interface material. To reduce the die-junction temperature, heat sinks can be attached to the package by several methods: adhesive, spring clip to holes in the printed-circuit board or package, or mounting clip and screw assembly. [Figure 27](#) displays a package-exploded cross-sectional view of a TBGA package with several heat sink options.

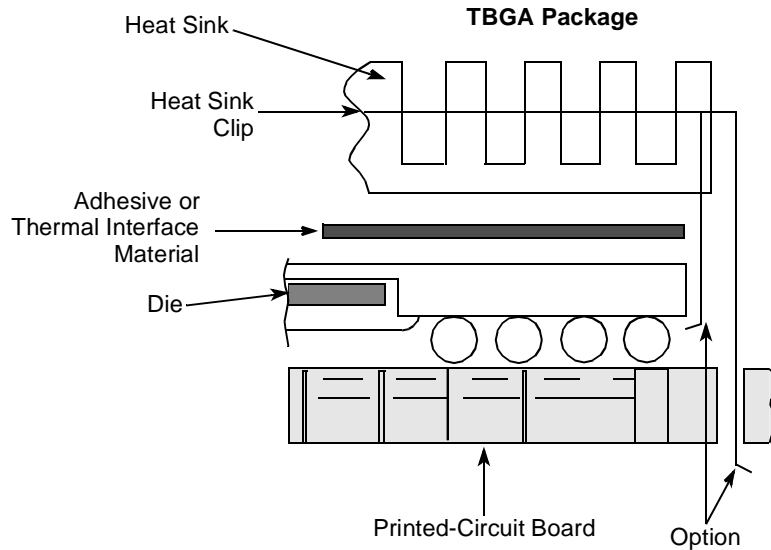

Figure 27. Package-Exploded Cross-Sectional View with Several Heat Sink Options

[Figure 28](#) depicts the die junction-to-ambient thermal resistance for four typical cases:

- A heat sink is not attached to the TBGA package, and there exists high board-level thermal loading from adjacent components.
- A heat sink is not attached to the TBGA package, and there is low board-level thermal loading from adjacent components.
- A heat sink (for example, ChipCoolers) is attached to the TBGA package, and there is high board-level thermal loading from adjacent components.
- A heat sink (for example, ChipCoolers) is attached to the TBGA package, and there is low board-level thermal loading from adjacent components.

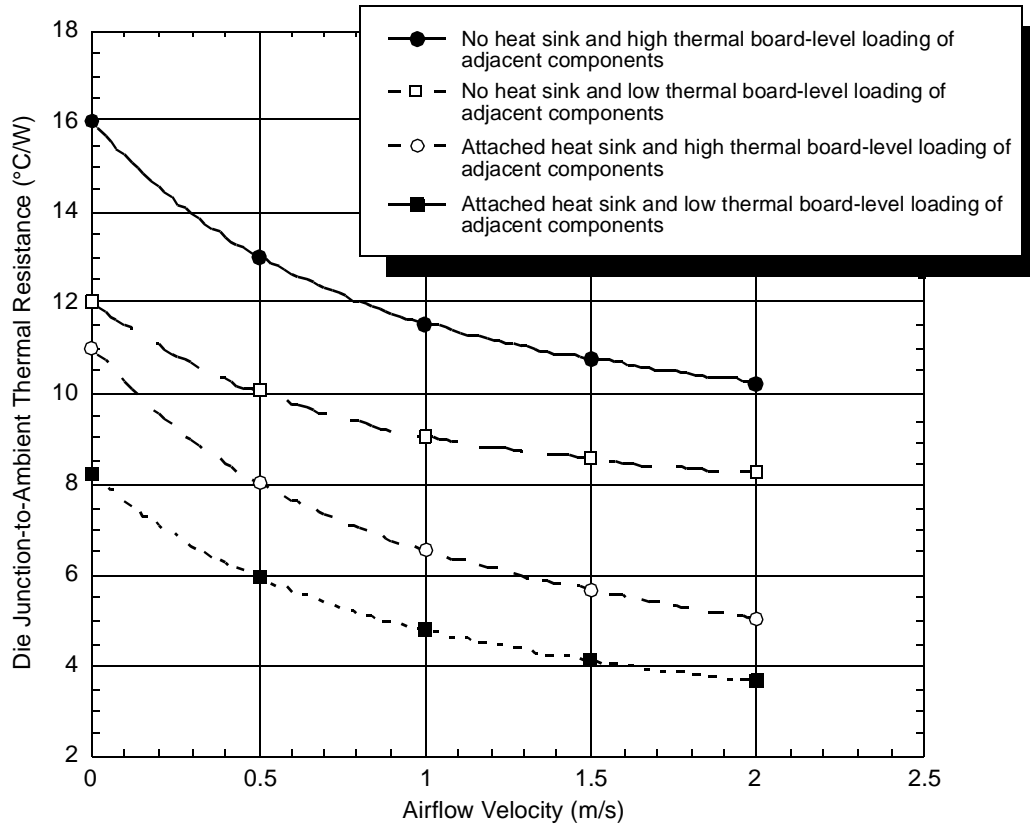

Figure 28. Die Junction-to-Ambient Resistance

The board designer can choose between several types of heat sinks to place on the MPC8245. Several commercially-available heat sinks for the MPC8245 are provided by the following vendors:

Aavid Thermalloy 603-224-9988
 80 Commercial St.
 Concord, NH 03301
 Internet: www.aavidthermalloy.com

Alpha Novatech 408-749-7601
 473 Sapena Ct. #15
 Santa Clara, CA 95054
 Internet: www.alphanovatech.com

International Electronic Research Corporation (IERC) 818-842-7277
 413 North Moss St.
 Burbank, CA 91502
 Internet: www.ctscorp.com

Tyco Electronics 800-522-6752
 Chip Coolers™
 P.O. Box 3668
 Harrisburg, PA 17105-3668
 Internet: www.chipcoolers.com

Wakefield Engineering
 33 Bridge St.
 Pelham, NH 03076
 Internet: www.wakefield.com

603-635-5102

Selection of an appropriate heat sink depends on thermal performance at a given air velocity, spatial volume, mass, attachment method, assembly, and cost. Other heat sinks offered by Aavid Thermalloy, Alpha Novatech, IERC, Chip Coolers, and Wakefield Engineering offer different heat sink-to-ambient thermal resistances and may or may not need airflow.

7.8.1 Internal Package Conduction Resistance

The intrinsic conduction thermal resistance paths for the TBGA cavity-down packaging technology shown in Figure 29 are as follows:

- Die junction-to-case thermal resistance
- Die junction-to-ball thermal resistance

Figure 29 depicts the primary heat transfer path for a package with an attached heat sink mounted on a printed-circuit board.

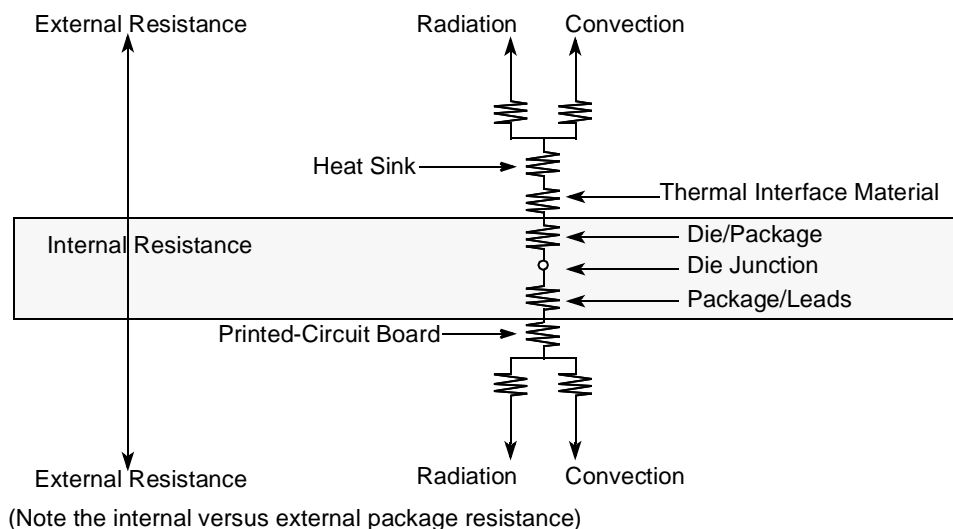

Figure 29. TBGA Package with Heat Sink Mounted to a Printed-Circuit Board

In a TBGA package, the active side of the die faces the printed-circuit board. Most of the heat travels through the die, across the die attach layer, and into the copper spreader. Some of the heat is removed from the top surface of the spreader through convection and radiation. Another percentage of the heat enters the printed-circuit board through the solder balls. The heat is then removed from the exposed surfaces of the board through convection and radiation. If a heat sink is used, a larger percentage of heat leaves through the top side of the spreader.

7.8.2 Adhesives and Thermal Interface Materials

A thermal interface material placed between the top of the package and the bottom of the heat sink minimizes thermal contact resistance. For applications that attach the heat sink by a spring clip mechanism, [Figure 30](#) shows the thermal performance of three thin-sheet thermal-interface materials (silicone, graphite/oil, floeroether oil), a bare joint, and a joint with thermal grease as a function of contact pressure. As shown, the performance of these thermal interface materials improves with increasing contact pressure. Thermal grease significantly reduces the interface thermal resistance. That is, the bare joint offers a thermal resistance approximately seven times greater than the thermal grease joint.

A spring clip attaches heat sinks to holes in the printed-circuit board (see [Figure 30](#)). Therefore, synthetic grease offers the best thermal performance, considering the low interface pressure. The selection of any thermal interface material depends on factors such as thermal performance requirements, manufacturability, service temperature, dielectric properties, and cost.

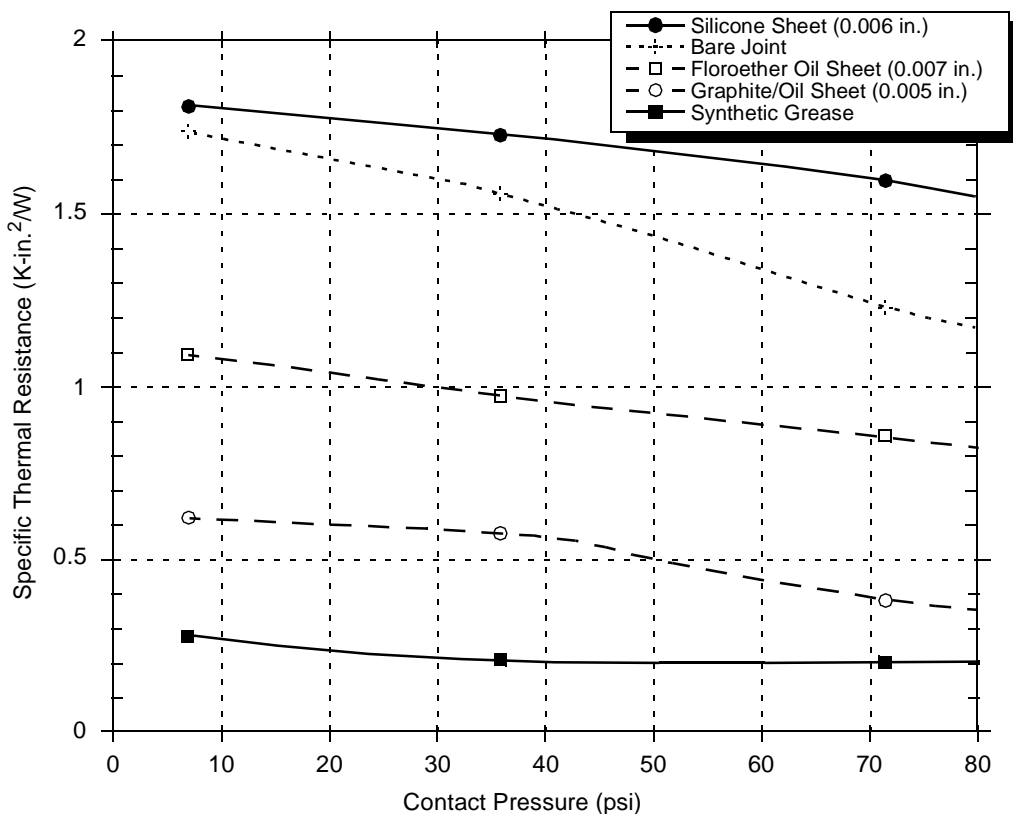

Figure 30. Thermal Performance of Select Thermal Interface Material

The board designer can choose between several types of thermal interfaces. Heat sink adhesive materials are selected on the basis of high conductivity and adequate mechanical strength to meet equipment shock/vibration requirements. Several commercially-available thermal interfaces and adhesive materials are provided by the following vendors:

Chomerics, Inc.
 77 Dragon Ct.
 Woburn, MA 01888-4014
 Internet: www.chomerics.com

781-935-4850

Dow-Corning Corporation Dow-Corning Electronic Materials 2200 W. Salzburg Rd. Midland, MI 48686-0997 Internet: www.dow.com	800-248-2481
Shin-Etsu MicroSi, Inc. 10028 S. 51st St. Phoenix, AZ 85044 Internet: www.microsi.com	888-642-7674
The Bergquist Company 18930 West 78 th St. Chanhassen, MN 55317 Internet: www.bergquistcompany.com	800-347-4572
Thermagon Inc. 4707 Detroit Ave. Cleveland, OH 44102 Internet: www.thermagon.com	888-246-9050

7.8.3 Heat Sink Usage

An estimation of the chip junction temperature, T_J , can be obtained from the equation:

$$T_J = T_A + (R_{\theta JA} \times P_D)$$

where

T_A = ambient temperature for the package ($^{\circ}\text{C}$)

$R_{\theta JA}$ = junction-to-ambient thermal resistance ($^{\circ}\text{C}/\text{W}$)

P_D = power dissipation in the package (W)

The junction-to-ambient thermal resistance is an industry-standard value that provides a quick and easy estimation of thermal performance. Unfortunately, two values are in common usage: the value determined on a single-layer board and the value obtained on a board with two planes. Which value is closer to the application depends on the power dissipated by other components on the board. The value obtained on a single-layer board is appropriate for the tightly packed printed-circuit board. The value obtained on the board with the internal planes is usually appropriate if the board has low power dissipation and the components are well separated.

When a heat sink is used, the thermal resistance is expressed as the sum of a junction-to-case thermal resistance and a case-to-ambient thermal resistance:

$$R_{\theta JA} = R_{\theta JC} + R_{\theta CA}$$

where

$R_{\theta JA}$ = junction-to-ambient thermal resistance ($^{\circ}\text{C}/\text{W}$)

$R_{\theta JC}$ = junction-to-case thermal resistance ($^{\circ}\text{C}/\text{W}$)

$R_{\theta CA}$ = case-to-ambient thermal resistance ($^{\circ}\text{C}/\text{W}$)

$R_{\theta JC}$ is device-related and cannot be influenced by the user. The user controls the thermal environment to change the case-to-ambient thermal resistance, $R_{\theta CA}$. For instance, the user can change the size of the heat sink, the airflow around the device, the interface material, the mounting arrangement on the printed-circuit board, or the thermal dissipation on the printed-circuit board surrounding the device.

To determine the junction temperature of the device in the application without a heat sink, the thermal characterization parameter (Ψ_{JT}) measures the temperature at the top center of the package case using the following equation:

$$T_J = T_T + (\Psi_{JT} \times P_D)$$

where:

T_T = thermocouple temperature atop the package ($^{\circ}\text{C}$)

Ψ_{JT} = thermal characterization parameter ($^{\circ}\text{C}/\text{W}$)

P_D = power dissipation in package (W)

The thermal characterization parameter is measured per JESD51-2 specification using a 40-gauge type T thermocouple epoxied to the top center of the package case. The thermocouple should be positioned so that the thermocouple junction rests on the package. A small amount of epoxy is placed over the thermocouple junction and over about 1 mm of wire extending from the junction. The thermocouple wire is placed flat against the package case to avoid measurement errors caused by cooling effects of the thermocouple wire.

When a heat sink is used, the junction temperature is determined from a thermocouple inserted at the interface between the case of the package and the interface material. A clearance slot or hole is normally required in the heat sink. Minimizing the size of the clearance minimizes the change in thermal performance caused by removing part of the thermal interface to the heat sink. Because of the experimental difficulties with this technique, many engineers measure the heat sink temperature and then back-calculate the case temperature using a separate measurement of the thermal resistance of the interface. From this case temperature, the junction temperature is determined from the junction-to-case thermal resistance.

In many cases, it is appropriate to simulate the system environment using a computational fluid dynamics thermal simulation tool. In such a tool, the simplest thermal model of a package that has demonstrated reasonable accuracy (about 20%) is a two-resistor model consisting of a junction-to-board and a junction-to-case thermal resistance. The junction-to-case covers the situation where a heat sink is used or a substantial amount of heat is dissipated from the top of the package. The junction-to-board thermal resistance describes the thermal performance when most of the heat is conducted to the printed-circuit board.

7.9 References

Semiconductor Equipment and Materials International
805 East Middlefield Rd.
Mountain View, CA 94043
(415) 964-5111

MIL-SPEC and EIA/JESD (JEDEC) specifications are available from Global Engineering Documents at 800-854-7179 or 303-397-7956.

JEDEC specifications are available on the web at <http://www.jedec.org>.

8 Document Revision History

Table 19 provides a revision history for this hardware specification.

Table 19. Revision History Table

Revision	Date	Substantive Change(s)
10	8/07	Section 3, Table 3, and Table 7—Changed format of recommended voltage supply values so that delta to the chosen nominal does not exceed ± 100 mV. Completely replaced Section 4.6 with compliant I ² C specifications as with other related integrated processor devices.
9	12/27/05	Document—Added Power Architecture information. Section 4.1—Changed increased absolute maximum range for V _{DD} in Table 1. Updated format of nominal voltage listings in Table 2. Section 9.2—Removed Note 3 from Table 21. Updated back page information.
8	11/15/2005	Document—Imported new template and made minor editorial changes. Removed references to a 466 MHz part since it is not available for new orders. Section 4.3.2—Added paragraph for using DLL mode that provides lowest locked tap point read in 0xE3. Section 5.3—Updated the driver and I/O assignment information for the multiplexed PCI clock and DUART signals. Added note for HRST_CPU and HRST_CTRL, which had been mentioned only in Figure 2. Section 9.2—Updated the part ordering specifications for the extended temperature parts. Also updated the section to reflect what we offer for new orders. Section 9.3—Added new section, “Part Marking.” Updated Figure 33 to match with current part marking format.
7	10/07/2004	Section 4.1.2—Table 2: Corrected range of AV _{DD} and AVDD ₂ . Section 9.1—Table 21: Corrected voltage range under Process Descriptor column. Minor reformatting.
6.1	05/24/2004	Section 4.5.3—Table 11: Spec 12b was improved from 4.5 ns to 4.0 ns. This improvement is guaranteed on devices marked after work week (WW) 28 of 2004. A device's work week may be determined from the “YYWW” portion of the device's trace ability code which is marked on the top of the device. So for WW28 in 2004, the device's YYWW is marked as 0428. For more information refer to Figure 33
6	05/11/2004	Section 4.1.2—Table 2: Corrected range of GV _{DD} to 3.3 \pm 5%. Section 4.2.1—Table 4: Changed the default for drive strength of DRV_STD_MEM. Section 4.5.1—Table 8: Changed the wording description for item 15. Section 4.5.2—Table 10: Changed T _{OS} range and wording in note; Figure 11:changed wording for SDRAM_SYNC_IN description relative to T _{OS} . Section 4.5.3—Table 11: Changed timing specification for sys_logic_clk to output valid (memory control, address, and data signals).
5.1	—	Section 4.3.1—Table 9: Corrected last row to state the correct description for the bit setting. Max tap delay, DLL extend. Figure 8: Corrected the label name for the DLL graph to state “DLL Locking Range Loop Delay vs. Frequency of Operation for DLL_Extend=1 and Normal Tap Delay”

Table 19. Revision History Table (continued)

Revision	Date	Substantive Change(s)
5	—	<p>Section 4.1.2 — Added note 6 and related label for latching of the PLL_CFG signals.</p> <p>Section 4.1.3 — Updated specifications for the input high and input low voltages of PCI_SYNC_IN.</p> <p>Section 4.3 — Table 7, updated specifications for the voltage range of V_{DD} for specific CPU frequencies.</p> <p>Section 4.3.1 — Table 8: Corrected typo for first number 1a to 1; Updated characteristics for the DLL lock range for the default and remaining three DLL locking modes; Reworded note description for note 6. Replaced contents of Table 9 with bit descriptions for the four DLL locking modes. In Figures 7 through 10, updated the DLL locking mode graphs.</p> <p>Section 4.3.2 — Table 10: Changed the name of references for timing parameters from SDRAM_SYNC_IN to <i>sys_logic_clk</i> to be consistent with Figure 11. Followed the same change for note 2.</p> <p>Section 4.3.3— Table 11: Changed the name of references for timing parameters from SDRAM_SYNC_IN to <i>sys_logic_clk</i> to be consistent with Figure 11. Followed the same change for note 2.</p> <p>Section 5.3 — Table 17: Removed extra listing of DRDY in Test/Configuration signal list and updated relevant notes for signal in Memory Interface signal listing. Updated note #20. Added note 26 for the signals of the UART interface.</p> <p>Section 7.6 — Added reference to AN2128 application note that highlights the differences between the MPC8240 and the MPC8245.</p> <p>Section 7.7 — Added relevant notes to this section and updated Figure 29.</p>
4	—	<p>Section 1.4.1.2—Updated notes for GV_{DD}, AV_{DD}, AV_{DD2}.</p> <p>Section 1.5.1—Updated solder ball information to include lead-free (V V) balls.</p> <p>Section 1.5.3—Updated Note 25 for QACK/DA0 signal. Added a sentence to Note 3.</p> <p>Section 1.6 —Incorporated Note 19 into Note 12 and modified Tables 18 and 19 accordingly.</p> <p>Section 1.9—Updated part marking nomenclature where appropriate to include the lead-free offering. Replaced reference to PNS document MPC8245RZUPNS with MPC8245ARZUPNS.</p>
3	—	<p>Section 1.4.1.2—Figure 2: Updated Note 2 and removed 'voltage regulator delay' label since Section 1.7.2 is being deleted this revision. Added Figures 4 and 5 to show voltage overshoot and undershoot of the PCI interface on the MPC8245.</p> <p>Section 1.4.1.3—Table 3: Updated the maximum input capacitance from 7 to 16 pF based on characterization data.</p> <p>Section 1.4.3.1—Updated PCI_SYNC_IN jitter specifications to 200 ps.</p> <p>Section 1.4.3.3—Table 11, item 12b: added the word 'address' to help clarify which signals the spec applies to. Figure 15: edited timing for items 12a0 and 12a2 to correspond with Table 11.</p> <p>Section 1.5.3—Updated notes for the QACK/DA0 signal because this signal has been found to have no internal pull resistor.</p> <p>Section 1.6—Corrected note numbers for reference numbers 3,10,1B, and 1C of the PLL tables. Updated PLL specifications for modes 7 and 1E.</p> <p>Section 1.7.2—Removed this section since the information already exists in Section 1.4.1.5.</p> <p>Section 1.7.4—Added the words 'the clamping voltage' to describe LV_{DD} in the sixth paragraph. Changed the QACK/DA0 signal from the list of signals having an internal pull-up resistor to the list of signals needing a weak pull-up resistor to OV_{DD}.</p> <p>Section 1.9.1—Tables 21 thru 23: Added processor version register value.</p>

Table 19. Revision History Table (continued)

Revision	Date	Substantive Change(s)
2	—	<p>Globally changed EPIC to PIC.</p> <p>Section 1.4.1.4—Note 5: Changed register reference from 0x72 to 0x73.</p> <p>Section 1.4.1.5—Table 5: Updated power dissipation numbers based on latest characterization data.</p> <p>Section 1.4.2—Table 6: Updated table to show more thermal specifications.</p> <p>Section 1.4.3—Table 7: Updated minimum memory bus value to 50 MHz.</p> <p>Section 1.4.3.1—Changed equations for DLL locking range based on characterization data. Added updates and reference to AN2164 for note 6. Added table defining Tdp parameters. Labeled N value in Figures 5 through 8.</p> <p>Section 1.4.3.2—Table 10: Changed bit definitions for tap points. Updated note on Tos and added reference to AN2164 for note 7. Updated Figure 9 to show significance of Tos.</p> <p>Section 1.4.3.4—Added column for SDRAM_CLK @ 133 MHz</p> <p>Sections 1.5.1 and 1.5.2—Corrected packaging information to state TBGA packaging.</p> <p>Section 1.5.3—Corrected some signals in Table 16 which were missing overbars in the Rev 1.0 release of the document.</p> <p>Section 1.6—Updated Note 10 of Tables 18 and 19.</p> <p>Section 1.7.3—Changed sentence recommendation regarding decoupling capacitors.</p> <p>Section 1.9—Updated format of tables in Ordering Information section.</p>
1	—	<p>Updated document template.</p> <p>Section 1.4.1.4—Changed the driver type names in Table 6 to match with the names used in the MPC8245 Reference Manual.</p> <p>Section 1.5.3—Updated driver type names for signals in Table 16 to match with names used in the MPC8245 Integrated Processor Reference Manual.</p> <p>Section 1.4.1.2—Updated Table 7 to refer to new PLL Tables for VCO limits.</p> <p>Section 1.4.3.3—Added item 12e to Table 10 for SDRAM_SYNC_IN to Output Valid timing.</p> <p>Section 1.5.1—Updated solder balls information to 62Sn/36PB/2Ag.</p> <p>Section 1.6—Updated PLL Tables 17 and 18 and appropriate notes to reflect changes of VCO ranges for memory and CPU frequencies.</p> <p>Section 1.7—Updated voltage sequencing requirements in Table 2 and removed Section 1.7.2.</p> <p>Section 1.7.8—Updated TRST information and Figure 26.</p> <p>New Section 1.7.2—Updated the range of I/O power consumption numbers for OV_{DD} and GV_{DD} to correct values as in Table 5. Updated fastest frequency combination to 66:100:350 MHz.</p> <p>Section 1.7.9—Updated list for heat sink and thermal interface vendors.</p> <p>Section 1.9—Changed format of Ordering Information section. Added tables to reflect part number specifications also available.</p> <p>Added Sections 1.9.2 and 1.9.3.</p>
0.5	—	<p>Corrected labels for Figures 5 through 8.</p>

Table 19. Revision History Table (continued)

Revision	Date	Substantive Change(s)
0.4	—	<p>Section 1.2—Changed Features list (format) to match with the features list of the <i>MPC8245 Integrated Processor Reference Manual</i>.</p> <p>Section 1.4.1.2—Updated Table 2 to include $1.8 \pm 100\text{mV}$ numbers.</p> <p>Section 1.4.3—Changed Table 7 to include new part offerings of 333 and 350 MHz. Added rows to include VCO frequency ranges for all parts for both memory VCO and CPU VCO.</p> <p>Section 1.4.1.5—Updated power consumption table to include 1.8 V (V_{DD}) and higher frequency numbers.</p> <p>Section 1.4.3—Updated Table 7 to include higher frequency offerings and CPU VCO frequency range.</p> <p>Section 1.4.3.1—Changed lettering to caps for DLL_EXTEND and DLL_MAX_DELAY in graph description section.</p> <p>Section 1.4.3.2—Changed name of item 11 from T_{su}—SDRAM_SYNC_IN to PCI_SYNC_IN Time to T_{os}—SDRAM_SYNC_IN to <i>sys_logic_clk</i> Offset Time. Changed name to T_{os} in Note 7 as well.</p> <p>Section 1.6—Updated notes in Table 17. Included minimum and maximum VCO numbers for memory VCO. Changed Note 13 for location of PLL_CFG[0:4] to correct bits location. Bits 7–4 of register offset <0xE2>. Added Table 18 to cover PLL configuration of higher frequency part offerings.</p> <p>Section: 1.7—Changed frequency ranges for reference numbers 0, 9, 10, and 17, for the 300-MHz part to include the higher memory bus frequencies when operating at lower CPU bus frequencies. Added Table 18 to include PLL configurations for the 333 MHz and the 350 MHz CPU part offerings. Added VCO multipliers in Tables 17 and 18.</p> <p>Section 1.7.8—Changed T_{su}—SDRAM_SYNC_IN to PCI_SYNC_IN Time to T_{os}—SDRAM_SYNC_IN to <i>sys_logic_clk</i> Offset Time.”</p> <p>Section 1.7.10—Added vendor (Cool Innovations, Inc.) to list of heat sink vendors.</p>
0.3	—	<p>Section 1.4.1.5—Changed Max-FP value for 33/133/266 of Table 5 from 2.3 to 2.1 watts to represent characterization data. Changed Note 4 to say $V_{DD} = 2.1$ for power measurements (for 2-V part). Changed numbers for maximum I/O power supplies for OV_{DD} and GV_{DD} to represent characterization data.</p> <p>Section 1.4.3.1—Added four graphs (Figures 5–8) and description for DLL Locking Range vs. Frequency of Operation to replace Figure 5 of Rev 0.2 document.</p> <p>Section 1.4.3.2—Added row (item 11: T_{su}—SDRAM_SYNC_IN to PCI_SYNC_IN timing) to Table 9 to include offset change requirement.</p> <p>Section 1.5.3—Changed Note 4 of PLL_CFG pins in Table 16 to Note 20.</p> <p>Section 1.7.2—Added diode (MUR420) to Figure 27, Voltage Sequencing Circuit, to compensate for voltage extremes in design.</p> <p>Section 1.7.5—Added sentence with regards to SDRAM_SYNC_IN to PCI_SYNC_IN timing requirement (T_{su}) as a connection recommendation.</p> <p>Section 1.7.8—Mention of T_{su} offset timing and driver capability differences between the MPC8240 and the MPC8245.</p>

Table 19. Revision History Table (continued)

Revision	Date	Substantive Change(s)
0.2	—	<p>Changed core supply voltage to 2.0 ± 100 mV in Section 1.3. (Supply voltage of 1.8 ± 100 mV is no longer recommended.)</p> <p>Changed rows 2, 5, and 6 of Table 2 to 2.0 ± 100 mV in the “Recommended Value” column.</p> <p>Changed the power consumption numbers in Table 5 to reflect the power values for $V_{DD} = 2.0$ V. (Notes 2, 3, 4, and 5 of the table were also updated to reflect the new value of V_{DD}.)</p> <p>Updated Table 9 for $V_{DD}/AV_{DD}/AV_{DD2}$ to 2.0 ± 100 mV.</p> <p>Table 8: $V_{DD}/AV_{DD}/AV_{DD2}$ was changed to 2.0 V for both CPU frequency offerings. Note 2 was updated by removing the “at reduced voltage...” statement.</p> <p>Table 10: Update maximum time of the rows 12a0 through 12a3.</p> <p>Table 16: Fixed overbars for the active-low signals. Changed pin type information for V_{DD}, AV_{DD}, and AV_{DD2} to 2.0 V.</p> <p>Changed Note 16 of Table 17 to a value of 2.0 V for $V_{DD}/AV_{DD}/AV_{DD2}$.</p> <p>Removed second sentence of the second paragraph in Section 1.7.2 because it referenced information about a 1.8-V design.</p> <p>Removed reference to 1.8 V in third sentence of Section 1.7.7.</p>

Table 19. Revision History Table (continued)

Revision	Date	Substantive Change(s)
0.1	—	<p>Made $V_{DD}/AV_{DD}/AV_{DD2} = 1.8\text{ V} \pm 100\text{ mV}$ information for 133-MHz memory interface operation to Section 1.3, Table 2, Table 5, Table 9, Table 17, and Section 1.7.2.</p> <p>Pin D17, formerly LAV_{DD} (supply voltage for DLL), is a NC on the MPC8245 since the DLL voltage is supplied internally. Eliminated all references to LAV_{DD}; updated Section 1.7.1.</p> <p>Previous Note 4 of Table 2 did not apply to the MPC8245 (MPC8240 document legacy). New Note 4 added in reference to maximum CPU speed at reduced V_{DD} voltage.</p> <p>Updated the Programmable Output Impedance of DEV_MEM_ADDR in Table 4 to $6\ \Omega$ to reflect characterization data.</p> <p>Updated Table 5 to reflect reduced power consumption when operating $V_{DD}/AV_{DD}/AV_{DD2} = 1.8\text{ V} \pm 100\text{ mV}$. Changed Notes 2, 3, and 4 to reflect V_{DD} at 1.9 V. Changed Note 5 to represent $V_{DD} = AV_{DD} = 1.8\text{ V}$.</p> <p>Updated Table 7 to reflect $V_{DD}/AV_{DD}/AV_{DD2}$ voltage level operating frequency dependencies; changed 250 MHz device column to 266 MHz; modified Note 1 eliminating VCO references; added Note 2. Changed 250 MHz processor frequency offering to 266 MHz.</p> <p>Changed Spec 12b for memory output valid time in Table 11 from 5.5 ns to 4.5 ns; this is a key specification change to enable 133-MHz memory interface designs.</p> <p>Updated Pinout Table 16 with the following changes:</p> <ul style="list-style-type: none"> • Pin types for $\overline{RCS0}$, $\overline{RCS3/TRIG_OUT}$ and $DA[11:15]$ were erroneously listed as I/O, changed Pin Types to Output. • Pin types for $\overline{REQ4/DA4}$, $\overline{RCS2/TRIG_IN}$, and $PLL_CFG[0:4]/DA[10:6]$ were erroneously listed as Input, changed Pin Types to I/O. • Changed Pin D17 from LAV_{DD} to No Connect; deleted Note 21 and references. • Notes 3, 5, and 7 contained references to the MPC8240 (MPC8240 document legacy); changed these references to MPC8245. • Previous Notes 13 and 14 did not apply to the MPC8245 (MPC8240 document legacy), these notes were deleted; moved Note 19 to become new Note 13; moved Note 20 to become new Note 14; updated associated references. • Added Note 3 to $SDMA[1:0]$ signals about internal pull-up resistors during reset state. • Reversed vector ordering for the PCI Interface Signals: $\overline{C/BE}[0:3]$ changed to $\overline{C/BE}[3:0]$, $AD[0:31]$ changed to $AD[31:0]$, $\overline{GNT}[0:3]$ changed to $\overline{GNT}[3:0]$, and $\overline{REQ}[0:3]$ changed to $\overline{REQ}[3:0]$. The package pin number orderings were also reversed meaning that pin functionality did NOT change. For example, AD0 is still on signal C22, AD1 is still on signal D22,..., AD31 is still on signal V25. This change was made to make the vectored PCI signals in this hardware specification consistent with the <i>PCI Local Bus Specification</i> and the <i>MPC8245 Integrated Processor Reference Manual</i> vector ordering. • Changed $\overline{TEST1/DRDY}$ signal on pin B20 to \overline{DRDY}. • Changed $\overline{TEST2}$ signal on pin Y2 to RTC for performance monitor use. <p>Updated PLL Table 17 with the following changes for 133-MHz memory interface operation:</p> <ul style="list-style-type: none"> • Added Ref. 9 (01001) and Ref. 17 (10111) details; removed these settings from Note 10 (reserved settings list). • Enhanced range of Ref. 10 (10000). • Updated Note 13, changed bits 16–20 erroneous information to correct bits 23–19. • Added Notes 16 and 17. <p>Added information to Section 1.7.8 in reference to $\overline{CHKSTOP_IN}$ and \overline{SRESET} being unavailable in extended ROM mode.</p>
0.0	—	Initial release.

9 Ordering Information

Ordering information for the parts fully covered by this specification document is provided in [Section 9.1, “Part Numbers Fully Addressed by This Document.”](#) [Section 9.2, “Part Numbers Not Fully Addressed by This Document,”](#) lists the part numbers that do not fully conform to the specifications of this document. These special part numbers require an additional document called a hardware specifications addendum.

9.1 Part Numbers Fully Addressed by This Document

[Table 20](#) provides the Freescale part numbering nomenclature for the MPC8245. Note that the individual part numbers correspond to a maximum processor core frequency. For available frequencies, contact a local Freescale sales office. In addition to the processor frequency, the part numbering scheme also includes an application modifier that may specify special application conditions. Each part number also contains a revision code that refers to the die mask revision number. The revision level can be determined by reading the Revision ID register at address offset 0x08.

Table 20. Part Numbering Nomenclature

MPC	nnnn	L	xx	nnn	x	
Product Code	Part Identifier	Process Descriptor	Package ¹	Processor Frequency ² (MHz)	Revision Level	Processor Version Register Value
MPC	8245	L: 0° to 105°C	ZU = TBGA VV = Lead-free TBGA	266, 300 1.7 V to 2.1 V	D:1.4 Rev ID:0x14	0x80811014
		L: 0° to 105°C	ZU = TBGA VV = Lead-free TBGA	333, 350 1.9 V to 2.2 V		

Notes:

1. See [Section 5, “Package Description,”](#) for more information on available package types.
2. Processor core frequencies supported by parts addressed by this specification only. Not all parts described in this specification support all core frequencies. Additionally, parts addressed by a hardware specifications addendum may support other maximum core frequencies.

9.2 Part Numbers Not Fully Addressed by This Document

Parts with application modifiers or revision levels not fully addressed in this specification document are described in separate part number specifications that supplement and supersede this document. [Table 21](#) shows the part numbers addressed by the MPC8245TXXnnnx series. The revision level can be determined by reading the Revision ID register at address offset 0x08.

**Table 21. Part Numbers Addressed by MPC8245TXXnnnx Series
Part Number Specification Markings
(Document Order No. MPC8245ECS01AD)**

MPC	nnnn	X	XX	nnn	X	
Product Code	Part Identifier	Process Descriptor	Package ¹	Processor Frequency ²	Revision Level	Processor Version Register Value
MPC	8245	T: -40° to 105°C	ZU = TBGA V V= Lead-free TBGA	266 MHz, 300 MHz: 1.7 V to 2.1 V 333 MHz, 350 MHz: 1.9 V to 2.2 V	D:1.4 Rev ID:0x14	0x80811014

Notes:

1. See [Section 5, "Package Description,"](#) for more information on available package types.
2. Processor core frequencies supported by parts addressed by this specification only. Not all parts described in this specification support all core frequencies. Additionally, parts addressed by a hardware specifications addendum may support other maximum core frequencies.

[Table 22](#) shows the part numbers addressed by the MPC8245ARZUnnnx series.

**Table 22. Part Numbers Addressed by MPC8245ARZUnnnx Series
Part Number Specification Markings
(Document Order No. MPC8245ECS02AD)**

MPC	nnnn	X	X	XX	nnn	X	
Product Code	Part Identifier	Process ³ Identifier	Process Descriptor	Package ¹	Processor Frequency ²	Revision Level	Processor Version Register Value
MPC	8245	A	R: 0° to 85°C	ZU = TBGA V V= Lead-free TBGA	400 MHz 2.1 V ± 100 mV	D:1.4 Rev ID:0x14	0x80811014

Notes:

1. See [Section 5, "Package Description,"](#) for more information on available package types.
2. Processor core frequencies supported by parts addressed by this specification only. Not all parts described in this specification support all core frequencies. Additionally, parts addressed by a hardware specifications addendum may support other maximum core frequencies.
3. Process identifier 'A' represents parts that are manufactured under a 29-angstrom process verses the original 35-angstrom process.

9.3 Part Marking

Parts are marked as the example shown in [Figure 31](#).

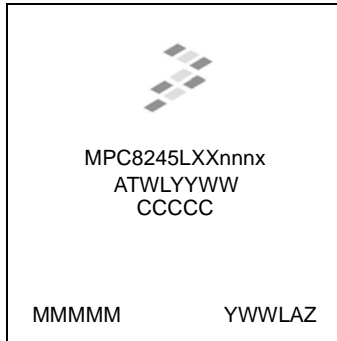

Notes:

- MMMMM is the 5-digit mask number.
- ATWLYYWW is test traceability code.
- YWWLAZ is the assembly traceability code.
- CCCCC is the country code.

Figure 31. Part Marking for TBGA Device

THIS PAGE INTENTIONALLY LEFT BLANK

THIS PAGE INTENTIONALLY LEFT BLANK

THIS PAGE INTENTIONALLY LEFT BLANK

How to Reach Us:

Home Page:

www.freescale.com

Web Support:

<http://www.freescale.com/support>

USA/Europe or Locations Not Listed:

Freescale Semiconductor, Inc.
 Technical Information Center, EL516
 2100 East Elliot Road
 Tempe, Arizona 85284
 +1-800-521-6274 or
 +1-480-768-2130
www.freescale.com/support

Europe, Middle East, and Africa:

Freescale Halbleiter Deutschland GmbH
 Technical Information Center
 Schatzbogen 7
 81829 Muenchen, Germany
 +44 1296 380 456 (English)
 +46 8 52200080 (English)
 +49 89 92103 559 (German)
 +33 1 69 35 48 48 (French)
www.freescale.com/support

Japan:

Freescale Semiconductor Japan Ltd.
 Headquarters
 ARCO Tower 15F
 1-8-1, Shimo-Meguro, Meguro-ku
 Tokyo 153-0064
 Japan
 0120 191014 or
 +81 3 5437 9125
support.japan@freescale.com

Asia/Pacific:

Freescale Semiconductor Hong Kong Ltd.
 Technical Information Center
 2 Dai King Street
 Tai Po Industrial Estate
 Tai Po, N.T., Hong Kong
 +800 2666 8080
support.asia@freescale.com

For Literature Requests Only:

Freescale Semiconductor
 Literature Distribution Center
 P.O. Box 5405
 Denver, Colorado 80217
 +1-800 441-2447 or
 +1-303-675-2140
 Fax: +1-303-675-2150
LDCForFreescaleSemiconductor@hibbertgroup.com

Information in this document is provided solely to enable system and software implementers to use Freescale Semiconductor products. There are no express or implied copyright licenses granted hereunder to design or fabricate any integrated circuits or integrated circuits based on the information in this document.

Freescale Semiconductor reserves the right to make changes without further notice to any products herein. Freescale Semiconductor makes no warranty, representation or guarantee regarding the suitability of its products for any particular purpose, nor does Freescale Semiconductor assume any liability arising out of the application or use of any product or circuit, and specifically disclaims any and all liability, including without limitation consequential or incidental damages. "Typical" parameters which may be provided in Freescale Semiconductor data sheets and/or specifications can and do vary in different applications and actual performance may vary over time. All operating parameters, including "Typicals" must be validated for each customer application by customer's technical experts. Freescale Semiconductor does not convey any license under its patent rights nor the rights of others. Freescale Semiconductor products are not designed, intended, or authorized for use as components in systems intended for surgical implant into the body, or other applications intended to support or sustain life, or for any other application in which the failure of the Freescale Semiconductor product could create a situation where personal injury or death may occur. Should Buyer purchase or use Freescale Semiconductor products for any such unintended or unauthorized application, Buyer shall indemnify and hold Freescale Semiconductor and its officers, employees, subsidiaries, affiliates, and distributors harmless against all claims, costs, damages, and expenses, and reasonable attorney fees arising out of, directly or indirectly, any claim of personal injury or death associated with such unintended or unauthorized use, even if such claim alleges that Freescale Semiconductor was negligent regarding the design or manufacture of the part.

Freescale™ and the Freescale logo are trademarks of Freescale Semiconductor, Inc. The Power Architecture and Power.org word marks and the Power and Power.org logos and related marks are trademarks and service marks licensed by Power.org. The described product contains a PowerPC processor core. The PowerPC name is a trademark of IBM Corp. and used under license. IEEE 1149.1 is a registered trademark of the Institute of Electrical and Electronics Engineers, Inc. (IEEE). This product is not endorsed or approved by the IEEE. TUNDRA, the Tundra logo, Tsi107, and Silicon Behind the Network are all trademarks of Tundra Semiconductor Corporation. All other product or service names are the property of their respective owners.

© Freescale Semiconductor, Inc., 2001–2007. All rights reserved.



Looking for pricing, stock, or lifecycle information?

Click below to explore more details on WIN SOURCE:

- ⊖ [View KMPC8245LZU266D on WIN SOURCE](#)
- ⊖ [NXP / Nexperia Information](#)

Optimize Your Supply Chain with WIN SOURCE Solutions

- ✓ Global Sourcing Solution
- ✓ Obsolete Management
- ✓ Cost Control Management
- ✓ Shortage Management
- ✓ Alternative Solution
- ✓ Excess Inventory Management