

Pb Free

RoHS Compliant

Features

- Miniature ceramic package
- Highly reliable with seam welding
- CMOS output
- Supply voltage $V_{DD}=3.3V$
- $\pm 25 \times 10^{-6}$ available

Table 1

Freq. Tol. Code	Freq. Tol. $\times 10^{-6}$	Operating Temperature Range (°C)	Note
0	± 50	-10 to +70	Standard specifications
S	± 30		
U	± 25	-40 to +85	With only certain frequencies
F	± 100		
G	± 50		

How to Order

KC7050C 25.0000 C 3 0 E 00
 ① ② ③ ④ ⑤ ⑥ ⑦

- ① Type (7.0x5.0mm SMD)
- ② Output Frequency
- ③ Output Type (CMOS)
- ④ Supply Voltage (3.3V)
- ⑤ Frequency Tolerance (See Table 1)
- ⑥ Symmetry/ Enable Function
(E: 45/55%, Stand-by) (D: 45/55%, Disable)
- ⑦ Customer Special Model Suffix
(STD Specification is "00")

Packaging (Tape & Reel 1000pcs./reel)

Specifications

Item	Symbol	Conditions	Min.	Max.	Units	
Output Frequency Range	Fo		1.5	80	MHz	
Frequency Tolerance	F _{tol}	Initial tolerance, Operating temperature range, Rated power supply voltage change, Load change, Aging (1year @25°C), Shock and vibration	Op. Temp.: -40 to +85°C	-100	+100	$\times 10^{-6}$
			Op. Temp.: -10 to +70°C/ -40 to +85°C	-50	+50	
			Op. Temp.: -10 to +70°C/ -40 to +85°C	-30	+30	
			Op. Temp.: -10 to +70°C	-25	+25	
Storage Temperature Range	T _{stg}		-55	+125	°C	
Operating Temperature Range	T _{use}	Standard Specifications	-10	+70	°C	
		Extend (Option)	-40	+85		
Max. Supply Voltage	—		-0.5	+7	V	
Supply Voltage	V _{DD}	Freq. Tol.Code: 0, S, F	2.97	3.63	V	
		Freq. Tol.Code: U, G	3.14	3.46		
Current Consumption (Maximum Loaded)	I _{DD}	1.5<Fo≤20MHz	—	10	mA	
		20<Fo≤40MHz	—	15		
		40<Fo≤60MHz	—	20		
		60<Fo≤80MHz	—	30		
Stand-by/Disable Current	I _{std} /I _{dis}	1.5<Fo≤32MHz (Stand-by Function)	—	10	μA	
		32<Fo≤50MHz (Disable Function)	—	15	mA	
		50<Fo≤80MHz (Stand-by Function)	—	10	μA	
Symmetry	SYM	@50% V _{DD}	45	55	%	
Rise/Fall Time (10% V _{DD} to 90% V _{DD} Maximum Loaded)	Tr/Tf	1.5<Fo≤26MHz	—	10	nS	
		26<Fo≤45MHz	—	8		
		45<Fo≤80MHz	—	5		
Output Voltage-"L"	V _{OL}	I _{OL} =8mA	—	10% V _{DD}	V	
Output Voltage-"H"	V _{OH}	I _{OH} =-8mA	90% V _{DD}	—	V	
Output Load	L _{CMOS}	CMOS Output	—	15	pF	
Input Voltage Range	V _{IN}		0	V _{DD}	V	
Input Voltage-"L"	V _{IL}		—	30% V _{DD}	V	
Input Voltage-"H"	V _{IH}		70% V _{DD}	—	V	
Disable Time	—		—	150	nS	
Enable Time	—	1.5<Fo≤32MHz (Stand-by Function)	—	5	mS	
		32<Fo≤50MHz (Disable Function)	—	150	nS	
		50<Fo≤80MHz (Stand-by Function)	—	5	mS	
Start-up Time	ST	@ Minimum Operation Voltage to be 0 sec.	—	10	mS	

Note: All electrical characteristics are defined at the maximum load and operating temperature range.
 Please contact us for inquiries about operating temperature range, available frequencies and other conditions.

Dimensions

(Unit : mm)

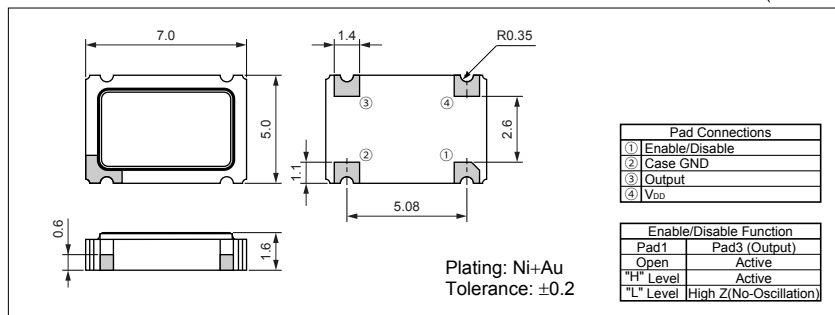

Recommended Land Pattern

(Unit : mm)

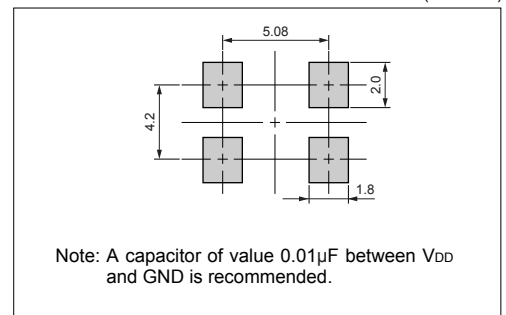



Looking for pricing, stock, or lifecycle information?

Click below to explore more details on WIN SOURCE:

-  [View K50-3C0SE66.6667MR on WIN SOURCE](#)
-  [AVX Corp/Kyocera Corp Information](#)

Optimize Your Supply Chain with WIN SOURCE Solutions

-  Global Sourcing Solution
-  Obsolete Management
-  Cost Control Management
-  Shortage Management
-  Alternative Solution
-  Excess Inventory Management