

ZLH SERIES
105°C Miniaturized, Long Life, Low Impedance

*Load Life : 105°C 6000~10000 hours.

RoHS compliance

◆SPECIFICATIONS

Items	Characteristics																														
Category Temperature Range	-40~+105°C																														
Rated Voltage Range	6.3~100Vdc																														
Capacitance Tolerance	±20% (20°C, 120Hz)																														
Leakage Current(MAX)	I=0.01CV or 3µA whichever is greater.(After 2 minutes) I=Leakage Current(µA) C=Capacitance(µF) V=Rated Voltage(Vdc)																														
Dissipation Factor(MAX) (tanδ)	<table border="1"> <thead> <tr> <th>Rated Voltage (Vdc)</th> <th>6.3</th> <th>10</th> <th>16</th> <th>25</th> <th>35</th> <th>50</th> <th>63</th> <th>80</th> <th>100</th> </tr> </thead> <tbody> <tr> <td>tanδ</td> <td>0.22</td> <td>0.19</td> <td>0.16</td> <td>0.14</td> <td>0.12</td> <td>0.10</td> <td>0.09</td> <td>0.08</td> <td>0.08</td> </tr> </tbody> </table> (20°C, 120Hz) When capacitance is over 1000µF, tanδ shall be added 0.02 to the listed value with increase of every 1000µF.	Rated Voltage (Vdc)	6.3	10	16	25	35	50	63	80	100	tanδ	0.22	0.19	0.16	0.14	0.12	0.10	0.09	0.08	0.08										
Rated Voltage (Vdc)	6.3	10	16	25	35	50	63	80	100																						
tanδ	0.22	0.19	0.16	0.14	0.12	0.10	0.09	0.08	0.08																						
Endurance	After applying rated voltage with rated ripple current for specified time at 105°C, the capacitors shall meet the following requirements. <table border="1"> <thead> <tr> <th>Capacitance Change</th> <td>Within ±25% of the initial value. (6.3Vdc, 10Vdc:±30%)</td> <th>Case Size</th> <th>Life Time (hrs)</th> </tr> </thead> <tbody> <tr> <td>Dissipation Factor</td> <td>Not more than 200% of the specified value.</td> <td>φD ≤ 6.3</td> <td>6000</td> </tr> <tr> <td>Leakage Current</td> <td>Not more than the specified value.</td> <td>φD = 8</td> <td>8000</td> </tr> <tr> <td></td> <td></td> <td>φD ≥ 10</td> <td>10000</td> </tr> </tbody> </table>	Capacitance Change	Within ±25% of the initial value. (6.3Vdc, 10Vdc:±30%)	Case Size	Life Time (hrs)	Dissipation Factor	Not more than 200% of the specified value.	φD ≤ 6.3	6000	Leakage Current	Not more than the specified value.	φD = 8	8000			φD ≥ 10	10000														
Capacitance Change	Within ±25% of the initial value. (6.3Vdc, 10Vdc:±30%)	Case Size	Life Time (hrs)																												
Dissipation Factor	Not more than 200% of the specified value.	φD ≤ 6.3	6000																												
Leakage Current	Not more than the specified value.	φD = 8	8000																												
		φD ≥ 10	10000																												
Low Temperature Stability Impedance Ratio(MAX)	<table border="1"> <thead> <tr> <th>Rated Voltage (Vdc)</th> <th>6.3</th> <th>10</th> <th>16</th> <th>25</th> <th>35</th> <th>50</th> <th>63</th> <th>80</th> <th>100</th> </tr> </thead> <tbody> <tr> <td>Z(-25°C)/Z(20°C)</td> <td>2</td> <td>2</td> <td>2</td> <td>2</td> <td>2</td> <td>2</td> <td>2</td> <td>2</td> <td>2</td> </tr> <tr> <td>Z(-40°C)/Z(20°C)</td> <td>3</td> <td>3</td> <td>3</td> <td>3</td> <td>3</td> <td>3</td> <td>3</td> <td>3</td> <td>3</td> </tr> </tbody> </table> (120Hz)	Rated Voltage (Vdc)	6.3	10	16	25	35	50	63	80	100	Z(-25°C)/Z(20°C)	2	2	2	2	2	2	2	2	2	Z(-40°C)/Z(20°C)	3	3	3	3	3	3	3	3	3
Rated Voltage (Vdc)	6.3	10	16	25	35	50	63	80	100																						
Z(-25°C)/Z(20°C)	2	2	2	2	2	2	2	2	2																						
Z(-40°C)/Z(20°C)	3	3	3	3	3	3	3	3	3																						

◆MULTIPLIER FOR RIPPLE CURRENT

Frequency (Hz)		120	1k	10k	100k≤
Coefficient	8.2~33µF	0.42	0.70	0.90	1.00
	47~270µF	0.50	0.73	0.92	1.00
	330~680µF	0.55	0.77	0.94	1.00
	820~1800µF	0.60	0.80	0.96	1.00
	2200~8200µF	0.70	0.85	0.98	1.00

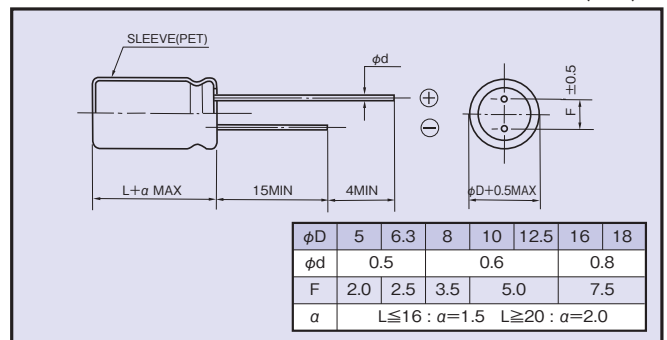
◆DIMENSIONS

◆PART NUMBER

□□□	ZLH	□□□□□	M	□□□	□□	DXL
Rated Voltage	Series	Capacitance	Capacitance Tolerance	Option	Lead Forming	Case Size

◆OPTION

Option	Code
PET Sleeve	EFC

◆STANDARD SIZE

Rated Voltage (Vdc)	Capacitance (μF)	Size φD×L(mm)	Rated ripple current (mA r.m.s./105°C, 100kHz)	Impedance (Ω MAX)	
				20°C, 100kHz	-10°C, 100kHz
6.3	220	5×11	345	0.22	0.80
	470	6.3×11	540	0.094	0.35
	820	8×11.5	945	0.056	0.19
	1200	8×16	1250	0.045	0.15
	1200	10×12.5	1330	0.039	0.14
	1500	8×20	1500	0.029	0.11
	1800	10×16	1760	0.028	0.10
	2200	10×20	1960	0.020	0.060
	2700	10×23	2250	0.018	0.054
	3900	12.5×20	2480	0.017	0.043
	4700	12.5×25	2900	0.015	0.038
	5600	12.5×30	3450	0.013	0.033
	6800	16×20	3250	0.015	0.038
	6800	12.5×35	3570	0.012	0.031
8200	16×25	3630	0.013	0.035	
10	150	5×11	345	0.22	0.80
	330	6.3×11	540	0.094	0.35
	680	8×11.5	945	0.056	0.19
	1000	8×16	1250	0.045	0.15
	1000	10×12.5	1330	0.039	0.14
	1500	8×20	1500	0.029	0.11
	1500	10×16	1760	0.028	0.10
	1800	10×20	1960	0.020	0.060
	2200	10×23	2250	0.018	0.054
	3300	12.5×20	2480	0.017	0.043
	3900	12.5×25	2900	0.015	0.038
	4700	12.5×30	3450	0.013	0.033
	4700	16×20	3250	0.015	0.038
	5600	12.5×35	3570	0.012	0.031
6800	16×25	3630	0.013	0.035	
16	100	5×11	345	0.22	0.80
	220	6.3×11	540	0.094	0.35
	470	8×11.5	945	0.056	0.19
	680	8×16	1250	0.045	0.15
	680	10×12.5	1330	0.039	0.14
	1000	8×20	1500	0.029	0.11
	1000	10×16	1760	0.028	0.10
	1500	10×20	1960	0.020	0.060
	1800	10×23	2250	0.018	0.054
	2200	12.5×20	2480	0.017	0.043
	2700	12.5×25	2900	0.015	0.038
	3300	12.5×30	3450	0.013	0.033
	3300	16×20	3250	0.015	0.038
	3900	12.5×35	3570	0.012	0.031
4700	16×25	3630	0.013	0.035	
25	68	5×11	345	0.22	0.80
	150	6.3×11	540	0.094	0.35
	330	8×11.5	945	0.056	0.19
	390	8×16	1250	0.045	0.15
	470	10×12.5	1330	0.039	0.14
	560	8×20	1500	0.029	0.11
	680	10×16	1760	0.028	0.10
	820	10×20	1960	0.020	0.060
	1000	10×23	2250	0.018	0.054
	1500	12.5×20	2480	0.017	0.043
	1800	12.5×25	2900	0.015	0.038
	2200	12.5×30	3450	0.013	0.033
	2200	16×20	3250	0.015	0.038
	2700	12.5×35	3570	0.012	0.031
3300	16×25	3630	0.013	0.035	
35	47	5×11	345	0.22	0.80
	100	6.3×11	540	0.094	0.35
	220	8×11.5	945	0.056	0.19
	270	8×16	1250	0.045	0.15
	330	10×12.5	1330	0.039	0.14
	390	8×20	1500	0.029	0.11
	470	10×16	1760	0.028	0.10
	560	10×20	1960	0.020	0.060
	680	10×23	2250	0.018	0.054
	1000	12.5×20	2480	0.017	0.043
	1200	12.5×25	2900	0.015	0.038
	1500	12.5×30	3450	0.013	0.033
	1500	16×20	3250	0.015	0.038
	1800	12.5×35	3570	0.012	0.031
2200	16×25	3630	0.013	0.035	
50	27	5×11	238	0.34	1.18
	56	6.3×11	385	0.14	0.50
	100	8×11.5	724	0.074	0.22
	120	8×16	950	0.061	0.18
	150	10×12.5	979	0.061	0.18
	180	8×20	1190	0.046	0.14
	220	10×16	1370	0.042	0.12
	270	10×20	1580	0.030	0.090
	330	10×23	1870	0.028	0.085
	470	12.5×20	2050	0.027	0.068
	560	12.5×25	2410	0.023	0.059
	680	12.5×30	2860	0.021	0.052
	820	12.5×35	2960	0.019	0.051
	820	16×20	2730	0.023	0.059
1000	16×25	3010	0.021	0.056	

◆STANDARD SIZE

Rated Voltage (Vdc)	Capacitance (μF)	Size φD×L(mm)	Rated ripple current (mA r.m.s./105°C, 100kHz)	Impedance (Ω MAX)	
				20°C, 100kHz	-10°C, 100kHz
63	18	5×11	173	0.88	3.5
	47	6.3×11	278	0.35	1.4
	82	8×11.5	525	0.22	0.88
	100	8×16	688	0.16	0.64
	120	10×12.5	725	0.15	0.60
	150	8×20	861	0.12	0.48
	180	10×16	998	0.11	0.44
	270	10×20	1200	0.078	0.31
	270	12.5×16	1200	0.082	0.27
	330	10×23	1410	0.069	0.28
	390	12.5×20	1570	0.060	0.19
	470	12.5×25	1990	0.043	0.14
	560	12.5×30	2410	0.035	0.13
	560	16×20	2100	0.043	0.14
	680	12.5×35	2620	0.033	0.11
	820	12.5×40	2940	0.027	0.090
	820	16×25	2730	0.032	0.096
	820	18×20	2500	0.038	0.10
	1200	16×31.5	2990	0.024	0.068
	1200	18×25	2800	0.031	0.084
80	12	5×11	163	1.4	5.6
	33	6.3×11	267	0.57	2.3
	56	8×11.5	462	0.36	1.4
	68	8×16	585	0.25	1.0
	82	10×12.5	624	0.23	0.96
	100	8×20	735	0.19	0.76
	120	10×16	780	0.17	0.72
	180	10×20	1040	0.12	0.52
	180	12.5×16	975	0.13	0.43
	220	10×23	1170	0.11	0.47
	270	12.5×20	1430	0.085	0.31
	330	12.5×25	1620	0.060	0.23
	390	12.5×30	1950	0.051	0.21
	390	16×20	1750	0.058	0.21
	470	12.5×35	2140	0.043	0.17
	560	12.5×40	2340	0.036	0.15
	560	16×25	2210	0.044	0.16
	560	18×20	1950	0.054	0.18
	680	16×31.5	2400	0.033	0.12
	820	16×35.5	2600	0.029	0.10
820	18×25	2270	0.038	0.13	
1000	16×40	2860	0.027	0.090	
1000	18×31.5	2470	0.031	0.11	
1200	18×35.5	2860	0.027	0.084	
1500	18×40	3510	0.026	0.076	

Rated Voltage (Vdc)	Capacitance (μF)	Size φD×L(mm)	Rated ripple current (mA r.m.s./105°C, 100kHz)	Impedance (Ω MAX)	
				20°C, 100kHz	-10°C, 100kHz
100	8.2	5×11	163	1.4	5.6
	18	6.3×11	267	0.57	2.3
	33	8×11.5	462	0.36	1.4
	47	8×16	585	0.25	1.0
	56	10×12.5	624	0.23	0.96
	68	8×20	735	0.19	0.76
	82	10×16	780	0.17	0.72
	100	10×20	1040	0.12	0.52
	100	12.5×16	975	0.13	0.43
	120	10×23	1170	0.11	0.47
	150	12.5×20	1430	0.085	0.31
	220	12.5×25	1620	0.060	0.23
	270	12.5×30	1950	0.051	0.21
	270	16×20	1750	0.058	0.21
	330	12.5×35	2140	0.043	0.17
	390	12.5×40	2340	0.036	0.15
	390	16×25	2210	0.044	0.16
	390	18×20	1950	0.054	0.18
	470	16×31.5	2400	0.033	0.12
	470	18×25	2270	0.038	0.13
560	16×35.5	2600	0.029	0.10	
560	18×31.5	2470	0.031	0.11	
680	16×40	2860	0.027	0.090	
680	18×35.5	2860	0.027	0.084	
820	18×40	3510	0.026	0.076	

Looking for pricing, stock, or lifecycle information?

Click below to explore more details on WIN SOURCE:

- ⊖ [View 50ZLH470MEFC12.5X20 on WIN SOURCE](#)
- ⊖ [Rubycon Information](#)

Optimize Your Supply Chain with WIN SOURCE Solutions

- ✓ Global Sourcing Solution
- ✓ Obsolete Management
- ✓ Cost Control Management
- ✓ Shortage Management
- ✓ Alternative Solution
- ✓ Excess Inventory Management