



**THE DATASHEET OF  
LMK00804BEVM**



## LMK00804B Low Skew, 1-to-4 Multiplexed Differential/LVCMOS-to-LVCMOS/TTL Fanout Buffer

### 1 Features

- Four LVCMOS/LVTTL Outputs with 7  $\Omega$  Output Impedance
  - Additive Jitter: 0.04 ps RMS (typ) @ 125 MHz
  - Noise Floor:  $-166$  dBc/Hz (typ) @ 125 MHz
  - Output Frequency: 350 MHz (max)
  - Output Skew: 35 ps (max)
  - Part-to-Part Skew: 700 ps (max)
- Two Selectable Inputs
  - CLK, nCLK Pair Accepts LVPECL, LVDS, HCSL, SSTL, LVHSTL, or LVCMOS/LVTTL
  - LVCMOS\_CLK Accepts LVCMOS/LVTTL
- Synchronous Clock Enable
- Core/Output Power Supplies:
  - 3.3 V/3.3 V
  - 3.3 V/2.5 V
  - 3.3 V/1.8 V
  - 3.3 V/1.5 V
- Package: 16-Lead TSSOP
- Industrial Temperature Range:  $-40^{\circ}\text{C}$  to  $+85^{\circ}\text{C}$

### 2 Applications

- Wireless and Wired Infrastructure
- Networking and Data Communications
- Servers and Computing
- Medical Imaging
- Portable Test and Measurement
- High-End A/V

### 4 Simplified Schematic

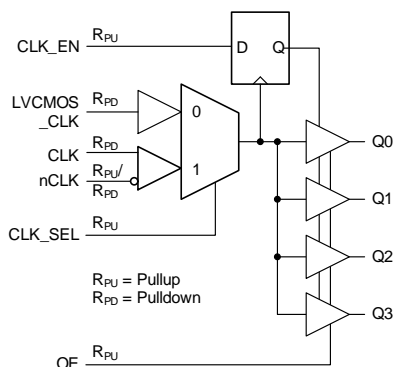

- (1)  $R_{PU} = 51$  k $\Omega$  pullup,  $R_{PD} = 51$  k $\Omega$  pulldown.  
See [Figure 10](#)

### 3 Description

The LMK00804B is a low skew, high performance clock fanout buffer which can distribute up to four LVCMOS/LVTTL outputs (3.3-V, 2.5-V, 1.8-V, or 1.5-V levels) from one of two selectable inputs, which can accept differential or single-ended inputs. The clock enable input is synchronized internally to eliminate runt or glitch pulses on the outputs when the clock enable terminal is asserted or de-asserted. The outputs are held in logic low state when the clock is disabled. A separate output enable terminal controls whether the outputs are active state or high-impedance state. The low additive jitter and phase noise floor, and guaranteed output and part-to-part skew characteristics make the LMK00804B ideal for applications demanding high performance and repeatability.

See also [Device Comparison Table](#) for descriptions of CDCLVC1310 and LMK00725 parts.

#### Device Information

PART NUMBER	PACKAGE	BODY SIZE (NOM)
LMK00804B	TSSOP (16)	5.00 mm x 4.40 mm

1. For all available packages, see the orderable addendum at the end of the datasheet.

#### Additive Jitter vs VDDO Supply and Temperature

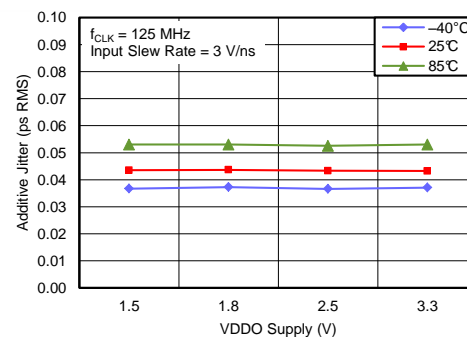



## 5 Device Comparison Table

PART NUMBER	DESCRIPTION
CDCLVC1310	10 outputs LVCMOS fanout buffer with Diff, Single-Ended, or Crystal Input
LMK00725	5 output LVPECL fanout buffer with Differential or Single-Ended Input

## 6 Pin Configuration and Functions

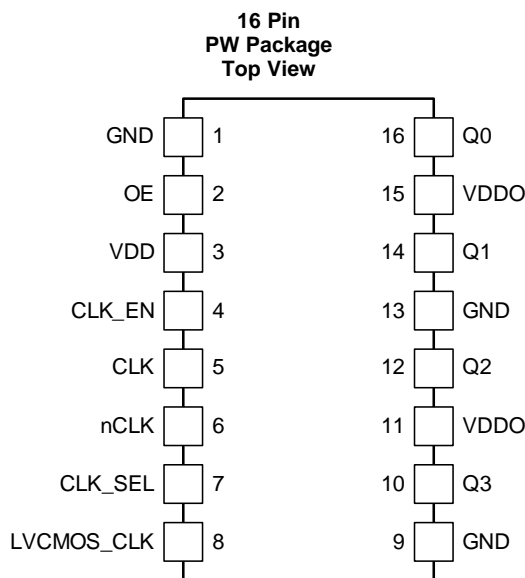

### Pin Functions

TERMINAL		TYPE <sup>(1)</sup>	DESCRIPTION
NAME	NUMBER		
GND	1, 9, 13	G	Power supply ground
OE	2	I, R <sub>PU</sub>	Output enable input. 0 = Outputs in Hi-Z state 1 = Outputs in active state
VDD	3	P	Power supply terminal
CLK_EN	4	I, R <sub>PU</sub>	Synchronous clock enable input. 0 = Outputs are forced to logic low state 1 = Outputs are enabled with LVCMOS/LVTTL levels
CLK	5	I, R <sub>PD</sub>	Non-inverting differential clock input 0.
nCLK	6	I, R <sub>PD</sub> /R <sub>PU</sub>	Inverting differential clock input 0. Internally biased to VDD/2 when left floating
CLK_SEL	7	I, R <sub>PU</sub>	Clock select input. 0 = Select LVCMOS_CLK 1 = Select CLK, nCLK
LVCMOS_CLK	8	I, R <sub>PD</sub>	Single-ended clock input. Accepts LVCMOS/LVTTL levels.
Q3, Q2, Q1, Q0	10, 12, 14, 16	O	Single-ended clock outputs with LVCMOS/LVTTL levels, 7Ω output impedance
VDDO	11, 15	P	Output supply terminals

(1) **G** = Ground, **I** = Input, **O** = Output, **P** = Power, **R<sub>PU</sub>** = 51 kΩ pullup, **R<sub>PD</sub>** = 51 kΩ pulldown.

## 7 Specifications

### 7.1 Pin Characteristics

		MIN	TYP	MAX	UNIT
$C_{IN}$	Input Capacitance		1		pF
$R_{PU}$	Input Pullup Resistance		51		k $\Omega$
$R_{PD}$	Input Pulldown Resistance		51		k $\Omega$
$C_{PD}$	Power Dissipation Capacitance (per output)		2		pF
$R_{OUT}$	Output impedance		7		$\Omega$

### 7.2 Absolute Maximum Ratings<sup>(1)(2)</sup>

Over operating free-air temperature range (unless otherwise noted)

		MIN	TYP	MAX	UNIT
VDD	Core Supply Voltage	-0.3		3.6	V
VDDO	Output Supply Voltage	-0.3		3.6	V
$V_{IN}$	Input Voltage Range	-0.3		VDD +0.3	V
$T_J$	Junction Temperature			150	$^{\circ}\text{C}$

- (1) Stresses beyond those listed under Absolute Maximum Ratings may cause permanent damage to the device. These are stress ratings only, and functional operation of the device at these or any other conditions beyond those indicated under *Recommended Operating Conditions* is not implied. Exposure to absolute-maximum-rated conditions for extended periods may affect device reliability.
- (2) If Military/Aerospace specified devices are required, please contact the Texas Instruments Sales Office/Distributors for availability and specifications.

### 7.3 Handling Ratings

		MIN	MAX	UNIT
$T_{stg}$	Storage temperature range	-65	150	$^{\circ}\text{C}$
$V_{(ESD)}$	Electrostatic discharge <sup>(1)</sup>	Human body model (HBM), per ANSI/ESDA/JEDEC JS-001, all pins <sup>(2)</sup>	1000	V
		Charged device model (CDM), per JEDEC specification JESD22-C101, all pins <sup>(3)</sup>	250	

- (1) Electrostatic discharge (ESD) to measure device sensitivity and immunity to damage caused by assembly line electrostatic discharges in to the device.
- (2) JEDEC document JEP155 states that 500-V HBM allows safe manufacturing with a standard ESD control process.
- (3) JEDEC document JEP157 states that 250-V CDM allows safe manufacturing with a standard ESD control process.

### 7.4 Recommended Operating Conditions

Over operating free-air temperature range (unless otherwise noted)

		MIN	TYP	MAX	UNIT
VDD	Core Supply Voltage	3.135	3.3	3.465	V
VDDO	Output Supply Voltage	3.135	3.3	3.465	V
		2.375	2.5	2.625	
		1.65	1.8	1.95	
		1.425	1.5	1.575	
$T_A$	Ambient Temperature	-40		85	$^{\circ}\text{C}$
$T_J$	Junction Temperature			125	$^{\circ}\text{C}$

## 7.5 Thermal Information

Over operating free-air temperature range (unless otherwise noted)

THERMAL METRIC <sup>(1)</sup>		MIN	TYP	MAX	UNIT
R <sub>θJA</sub>	Package Thermal Impedance, Junction to Air (0 LFPM)			116	°C/W

(1) For more information about traditional and new thermal metrics, see the *IC Package Thermal Metrics* application report, [SPRA953](#).

## 7.6 Power Supply Characteristics

Over operating free-air temperature range (unless otherwise noted)

PARAMETER		MIN	TYP	MAX	UNIT
IDD	Power Supply Current through VDD			21	mA
IDDO	Power Supply Current through VDDO			5	mA

## 7.7 LVC MOS / LV TTL DC Characteristics

Over operating free-air temperature range (unless otherwise noted)

PARAMETER		TEST CONDITIONS	MIN	TYP	MAX	UNIT
V <sub>IH</sub>	Input High Voltage	CLK_EN, CLK_SEL, OE	2		VDD + 0.3	V
		LVC MOS_CLK	2		VDD + 0.3	V
V <sub>IL</sub>	Input Low Voltage	CLK_EN, CLK_SEL, OE	-0.3		0.8	V
		LVC MOS_CLK	-0.3		1.3	V
I <sub>IH</sub>	Input High Current	CLK_EN, CLK_SEL, OE			5	μA
		LVC MOS_CLK			150	
I <sub>IL</sub>	Input Low Current	CLK_EN, CLK_SEL, OE			-150	μA
		LVC MOS_CLK			-5	
V <sub>OH</sub>	Output High Voltage <sup>(1)</sup>	VDDO = 3.3 V ± 5%	2.6			V
		VDDO = 2.5 V ± 5%	1.8			
		VDDO = 1.8 V ± 0.15 V	1.5			
		VDDO = 1.5 V ± 5%		VDDO - 0.3		
V <sub>OL</sub>	Output Low Voltage <sup>(1)</sup>	VDDO = 3.3 V ± 5%			0.5	V
		VDDO = 2.5 V ± 5%			0.5	
		VDDO = 1.8 V ± 0.15 V			0.4	
		VDDO = 1.5 V ± 5%			0.35	
I <sub>OZL</sub>	Output Hi-Z Current Low		-5			μA
I <sub>OZH</sub>	Output Hi-Z Current High				5	

(1) Outputs terminated with 50 Ω to VDDO/2.

## 7.8 Differential Input DC Characteristics

Over operating free-air temperature range (unless otherwise noted)

PARAMETER		TEST CONDITIONS	MIN	TYP	MAX	UNIT
V <sub>ID</sub>	Differential Input Voltage Swing, (V <sub>IH</sub> -V <sub>IL</sub> ) <sup>(1)</sup>		0.15		1.3	V
V <sub>ICM</sub>	Input Common Mode Voltage <sup>(1)(2)</sup>		0.5		VDD – 0.85	V
I <sub>IH</sub>	Input High Current <sup>(3)</sup>	nCLK			150	μA
		CLK	VDD = 3.465 V, V <sub>IN</sub> = 3.465 V		150	
I <sub>IL</sub>	Input Low Current <sup>(3)</sup>	nCLK			-150	μA
		CLK	VDD = 3.465 V, V <sub>IN</sub> = 0 V		-5	

 (1) V<sub>IL</sub> should not be less than -0.3 V.

 (2) Input common mode voltage is defined as V<sub>IH</sub>.

 (3) For I<sub>IH</sub> and I<sub>IL</sub> measurements on CLK or nCLK, one must comply with V<sub>ID</sub> and V<sub>ICM</sub> specifications by using the appropriate bias on nCLK or CLK.

## 7.9 Electrical Characteristics (VDDO = 3.3 V ± 5%)

Over recommended operating free-air temperature range (unless otherwise noted), VDD = VDDO = 3.3V ± 5%,

All AC parameters measured at ≤ 350 MHz unless otherwise noted.

PARAMETER		TEST CONDITIONS	MIN	TYP	MAX	UNIT
f <sub>OUT</sub>	Maximum Output Frequency <sup>(1)(2)</sup>				350	MHz
t <sub>PDLH</sub>	Propagation Delay, Low to High <sup>(3)</sup>	LVC MOS_CLK <sup>(4)</sup> , CLK/nCLK <sup>(5)</sup>	0°C to 70°C		2.1	ns
			-40°C to 85°C		2.2	ns
t <sub>SK(O)</sub>	Output Skew <sup>(2)(6)(7)</sup>	Measured on rising edge			35	ps
t <sub>SK(PP)</sub>	Part-to-Part Skew <sup>(3)(7)(8)</sup>				700	ps
t <sub>R</sub> /t <sub>F</sub>	Output Rise/Fall Time <sup>(3)</sup>	20% to 80%			700	ps
J <sub>ADD</sub>	Additive Jitter <sup>(9)</sup>	f=125 MHz, Input slew rate ≥ 3 V/ns, 12 kHz to 20 MHz integration band		0.04		ps RMS

 (1) There is no minimum input / output frequency provided the input slew rate is sufficiently fast. Refer to [Input Slew Rate Considerations](#).

(2) These AC parameters are specified by characterization. Not tested in production.

(3) These AC parameters are specified by design. Not tested in production

(4) Measured from the VDD/2 of the input to the VDDO/2 of the output.

(5) Measured from the differential input crossing point to VDDO/2 of the output.

(6) Defined as skew between outputs at the same supply voltage and with equal loading conditions. Measured at VDDO/2 of the output.

(7) Parameter is defined in accordance with JEDEC Standard 65.

 (8) Calculation for part-to-part skew is the difference between the fastest and slowest t<sub>PD</sub> across multiple devices, operating at the same supply voltage, same frequency, same temperature, with equal load conditions, and using the same type of inputs on each device.

 (9) Buffer Additive Jitter: J<sub>ADD</sub> = SQRT(J<sub>SYSTEM</sub><sup>2</sup> - J<sub>SOURCE</sub><sup>2</sup>), where J<sub>SYSTEM</sub> is the RMS jitter of the system output (source+buffer) and J<sub>SOURCE</sub> is the RMS jitter of the input source, and system output noise is not correlated to the input source noise. Additive jitter should be considered only when the input source noise floor is 3 dB or better than the buffer noise floor (PN<sub>FLOOR</sub>). This is usually the case for high-quality ultra-low-noise oscillators. Please refer to [System-Level Phase Noise and Additive Jitter Measurement](#) for input source and measurement details.

## Electrical Characteristics (VDDO = 3.3 V ± 5%) (continued)

Over recommended operating free-air temperature range (unless otherwise noted), VDD = VDDO = 3.3V ± 5%, All AC parameters measured at ≤ 350 MHz unless otherwise noted.

PARAMETER		TEST CONDITIONS	MIN	TYP	MAX	UNIT
PN <sub>FLOOR</sub>	Phase Noise Floor <sup>(10)</sup>	f = 125 MHz, Input slew rate ≥ 3 V/ns				dBc/Hz
		10 kHz offset		-155		
		100 kHz offset		-162		
		1 MHz offset		-166		
		10 MHz offset		-166		
ODC	Output Duty Cycle <sup>(11)(12)</sup>	REF = CLK/nCLK	45%		55%	
		REF = LVCMOS_CLK, f ≤ 300 MHz	45%		55%	
t <sub>EN</sub>	Output Enable Time			5		ns
t <sub>DIS</sub>	Output Disable Time			5		ns

(10) Buffer Phase Noise Floor: PN<sub>FLOOR</sub> (dBc/Hz) = 10 x log<sub>10</sub>[10<sup>(PN<sub>SYSTEM</sub>/10)</sup> – 10<sup>(PN<sub>SOURCE</sub>/10)</sup>], where PN<sub>SYSTEM</sub> is the phase noise floor of the system output (source+buffer) and PN<sub>SOURCE</sub> is the phase noise floor of the input source. Buffer Phase Noise Floor should be considered only when the input source noise floor is 3 dB or better than the buffer noise floor (PN<sub>FLOOR</sub>). This is usually the case for high-quality ultra-low-noise oscillators. Please refer to System-Level Phase Noise and Additive Jitter Measurement for input source and measurement details.

(11) These AC parameters are specified by design. Not tested in production

(12) 50% Input duty cycle

## 7.10 Electrical Characteristics (VDDO = 2.5 V ± 5%)

Over recommended operating free-air temperature range (unless otherwise noted), VDD = 3.3V ± 5%, VDDO = 2.5V ± 5%, All AC parameters measured at ≤ 350 MHz unless otherwise noted.

PARAMETER		TEST CONDITIONS	MIN	TYP	MAX	UNIT
f <sub>OUT</sub>	Maximum Output Frequency <sup>(1) (2)</sup>				350	MHz
t <sub>PDLH</sub>	Propagation Delay, Low to High <sup>(3)</sup>	LVCMOS_CLK <sup>(4)</sup> , CLK/nCLK <sup>(5)</sup>	0°C to 70°C	1.1	2.1	ns
			–40°C to 85°C	0.95	2.2	
t <sub>SK(O)</sub>	Output Skew <sup>(2) (6)(7)</sup>	Measured on rising edge			35	ps
t <sub>SK(PP)</sub>	Part-to-Part Skew <sup>(3)(7)(8)</sup>				700	ps
t <sub>R</sub> /t <sub>F</sub>	Output Rise/Fall Time <sup>(3)</sup>	20% to 80%	50		700	ps
J <sub>ADD</sub>	Additive Jitter <sup>(9)</sup>	f=125 MHz, Input slew rate ≥ 3 V/ns, 12 kHz to 20 MHz integration band		0.04		ps RMS
ODC	Output Duty Cycle <sup>(3)(10)</sup>	REF = CLK/nCLK	45%		55%	
		REF = LVCMOS_CLK, f ≤ 300 MHz	45%		55%	
t <sub>EN</sub>	Output Enable Time			5		ns
t <sub>DIS</sub>	Output Disable Time			5		ns

(1) There is no minimum input / output frequency provided the input slew rate is sufficiently fast. Refer to [Input Slew Rate Considerations](#).

(2) These AC parameters are specified by characterization. Not tested in production.

(3) These AC parameters are specified by design. Not tested in production.

(4) Measured from the VDD/2 of the input to the VDDO/2 of the output.

(5) Measured from the differential input crossing point to VDDO/2 of the output.

(6) Defined as skew between outputs at the same supply voltage and with equal loading conditions. Measured at VDDO/2 of the output.

(7) Parameter is defined in accordance with JEDEC Standard 65.

(8) Calculation for part-to-part skew is the difference between the fastest and slowest t<sub>PD</sub> across multiple devices, operating at the same supply voltage, same frequency, same temperature, with equal load conditions, and using the same type of inputs on each device.

(9) Buffer Additive Jitter: J<sub>ADD</sub> = SQRT(J<sub>SYSTEM</sub><sup>2</sup> - J<sub>SOURCE</sub><sup>2</sup>), where J<sub>SYSTEM</sub> is the RMS jitter of the system output (source+buffer) and J<sub>SOURCE</sub> is the RMS jitter of the input source, and system output noise is not correlated to the input source noise. Additive jitter should be considered only when the input source noise floor is 3 dB or better than the buffer noise floor (PN<sub>FLOOR</sub>). This is usually the case for high-quality ultra-low-noise oscillators. Please refer to [System-Level Phase Noise and Additive Jitter Measurement](#) for input source and measurement details.

(10) 50% Input Duty Cycle

## 7.11 Electrical Characteristics (VDDO = 1.8 V ± 0.15 V)

Over recommended operating free-air temperature range (unless otherwise noted), VDD = 3.3 V ± 5%, VDDO = 1.8 V ± 0.15 V. All AC parameters measured at ≤ 350 MHz unless otherwise noted.

PARAMETER		TEST CONDITIONS	MIN	TYP	MAX	UNIT	
f <sub>OUT</sub>	Maximum Output Frequency <sup>(1)(2)</sup>				350	MHz	
t <sub>PDLH</sub>	Propagation Delay, Low to High <sup>(3)</sup>	LVCOSM_CLK <sup>(4)</sup> , CLK/nCLK <sup>(5)</sup>	0°C to 70°C		1.1	2.2	ns
			–40°C to 85°C		0.95	2.3	ns
t <sub>SK(O)</sub>	Output Skew <sup>(2)(6)(7)</sup>	Measured on rising edge			35	ps	
t <sub>SK(PP)</sub>	Part-to-Part Skew <sup>(3)(7)(8)</sup>				700	ps	
t <sub>R</sub> /t <sub>F</sub>	Output Rise/Fall Time <sup>(3)</sup>	20% to 80%		100	700	ps	
J <sub>ADD</sub>	Additive Jitter <sup>(9)</sup>	f=125 MHz, Input slew rate ≥ 3 V/ns, 12 kHz to 20 MHz integration band		0.04		ps RMS	
ODC	Output Duty Cycle <sup>(3)(10)</sup>	REF = CLK/nCLK		45%	55%		
		REF = LVCOSM_CLK, f ≤ 300 MHz		45%	55%		
t <sub>EN</sub>	Output Enable Time			5		ns	
t <sub>DIS</sub>	Output Disable Time			5		ns	

- (1) There is no minimum input / output frequency provided the input slew rate is sufficiently fast. Refer to [Input Slew Rate Considerations](#).
- (2) These AC parameters are specified by characterization. Not tested in production.
- (3) These AC parameters are specified by design. Not tested in production.
- (4) Measured from the VDD/2 of the input to the VDDO/2 of the output.
- (5) Measured from the differential input crossing point to VDDO/2 of the output.
- (6) Defined as skew between outputs at the same supply voltage and with equal loading conditions. Measured at VDDO/2 of the output.
- (7) Parameter is defined in accordance with JEDEC Standard 65.
- (8) Calculation for part-to-part skew is the difference between the fastest and slowest t<sub>PD</sub> across multiple devices, operating at the same supply voltage, same frequency, same temperature, with equal load conditions, and using the same type of inputs on each device.
- (9) Buffer Additive Jitter: J<sub>ADD</sub> = SQRT(J<sub>SYSTEM</sub><sup>2</sup> - J<sub>SOURCE</sub><sup>2</sup>), where J<sub>SYSTEM</sub> is the RMS jitter of the system output (source+buffer) and J<sub>SOURCE</sub> is the RMS jitter of the input source, and system output noise is not correlated to the input source noise. Additive jitter should be considered only when the input source noise floor is 3 dB or better than the buffer noise floor (PN<sub>FLOOR</sub>). This is usually the case for high-quality ultra-low-noise oscillators. Please refer to [System-Level Phase Noise and Additive Jitter Measurement](#) for input source and measurement details.
- (10) 50% Input Duty Cycle

## 7.12 Electrical Characteristics (VDDO = 1.5 V ± 5%)

Over recommended operating free-air temperature range (unless otherwise noted), VDD = 3.3V ± 5%, VDDO = 1.5V ± 5%, All AC parameters measured at ≤ 350 MHz unless otherwise noted.

PARAMETER		TEST CONDITIONS	MIN	TYP	MAX	UNIT	
f <sub>OUT</sub>	Maximum Output Frequency <sup>(1)(2)</sup>				350	MHz	
t <sub>PDLH</sub>	Propagation Delay, Low to High <sup>(3)</sup>	LVC MOS_CLK <sup>(4)</sup> , CLK/nCLK <sup>(5)</sup>	0°C to 70°C		1.1	2.2	ns
			–40°C to 85°C		0.95	2.3	ns
t <sub>SK(O)</sub>	Output Skew <sup>(2)(6)(7)</sup>	Measured on rising edge			35	ps	
t <sub>SK(PP)</sub>	Part-to-Part Skew <sup>(2)(7)(8)</sup>				1	ns	
t <sub>R</sub> /t <sub>F</sub>	Output Rise/Fall Time <sup>(3)</sup>	20% to 80%		100	900	ps	
J <sub>ADD</sub>	Additive Jitter <sup>(9)</sup>	f=125 MHz, Input slew rate ≥ 3 V/ns, 12 kHz to 20 MHz integration band		0.04		ps RMS	
ODC	Output Duty Cycle <sup>(3)(10)</sup>	f ≤ 166 MHz		45%	55%		
		f > 166 MHz		42%	58%		
t <sub>EN</sub>	Output Enable Time			5		ns	
t <sub>DIS</sub>	Output Disable Time			5		ns	

- (1) There is no minimum input / output frequency provided the input slew rate is sufficiently fast. Refer to [Input Slew Rate Considerations](#).
- (2) These AC parameters are specified by characterization. Not tested in production.
- (3) These AC parameters are specified by design. Not tested in production.
- (4) Measured from the VDD/2 of the input to the VDDO/2 of the output.
- (5) Measured from the differential input crossing point to VDDO/2 of the output.
- (6) Defined as skew between outputs at the same supply voltage and with equal loading conditions. Measured at VDDO/2 of the output.
- (7) Parameter is defined in accordance with JEDEC Standard 65.
- (8) Calculation for part-to-part skew is the difference between the fastest and slowest t<sub>PD</sub> across multiple devices, operating at the same supply voltage, same frequency, same temperature, with equal load conditions, and using the same type of inputs on each device.
- (9) Buffer Additive Jitter: J<sub>ADD</sub> = SQRT(J<sub>SYSTEM</sub><sup>2</sup> - J<sub>SOURCE</sub><sup>2</sup>), where J<sub>SYSTEM</sub> is the RMS jitter of the system output (source+buffer) and J<sub>SOURCE</sub> is the RMS jitter of the input source, and system output noise is not correlated to the input source noise. Additive jitter should be considered only when the input source noise floor is 3 dB or better than the buffer noise floor (PN<sub>FLOOR</sub>). This is usually the case for high-quality ultra-low-noise oscillators. Please refer to [System-Level Phase Noise and Additive Jitter Measurement](#) for input source and measurement details.
- (10) 50% Input Duty Cycle

### 7.13 Typical Characteristics

Unless otherwise noted: VDD = 3.3 V, VDDO = 3.3 V, T<sub>A</sub> = 25°C

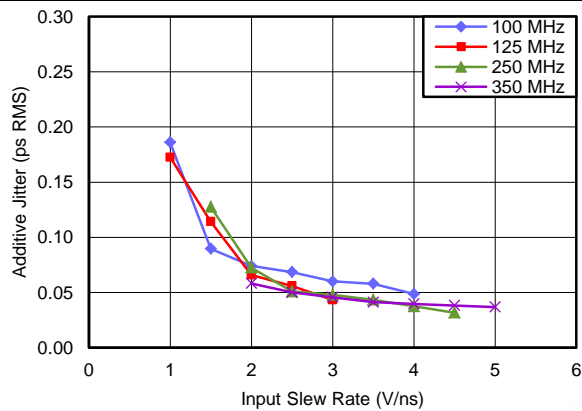

Figure 1. Additive Jitter vs Input Slew Rate

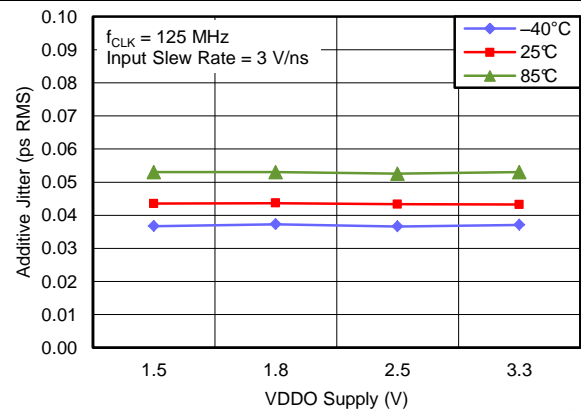

Figure 2. Additive Jitter vs VDDO Supply and Temperature

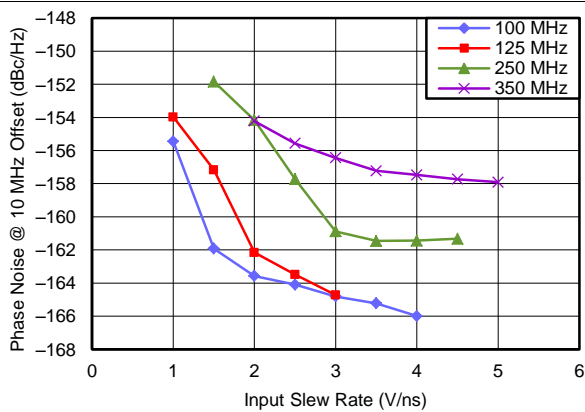

Figure 3. Phase Noise Floor vs Input Slew Rate

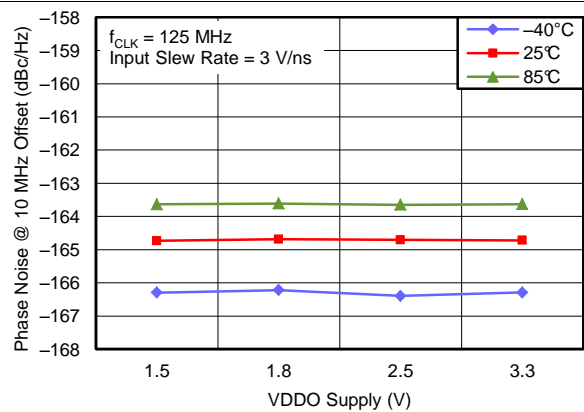
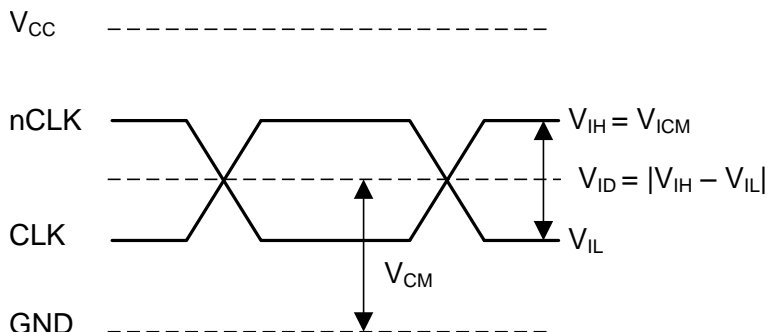

Figure 4. Phase Noise Floor vs VDDO Supply and Temperature

## 8 Parameter Measurement Information



NOTE:  $V_{CM} = V_{ICM} - V_{ID}/2 = (V_{IH} + V_{IL})/2$

Figure 5. Differential Input Level

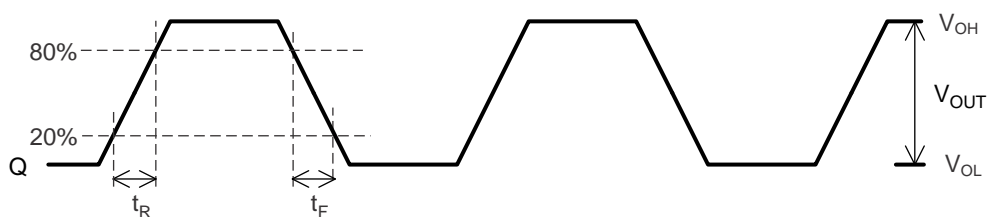

Figure 6. Output Voltage, and Rise and Fall Times

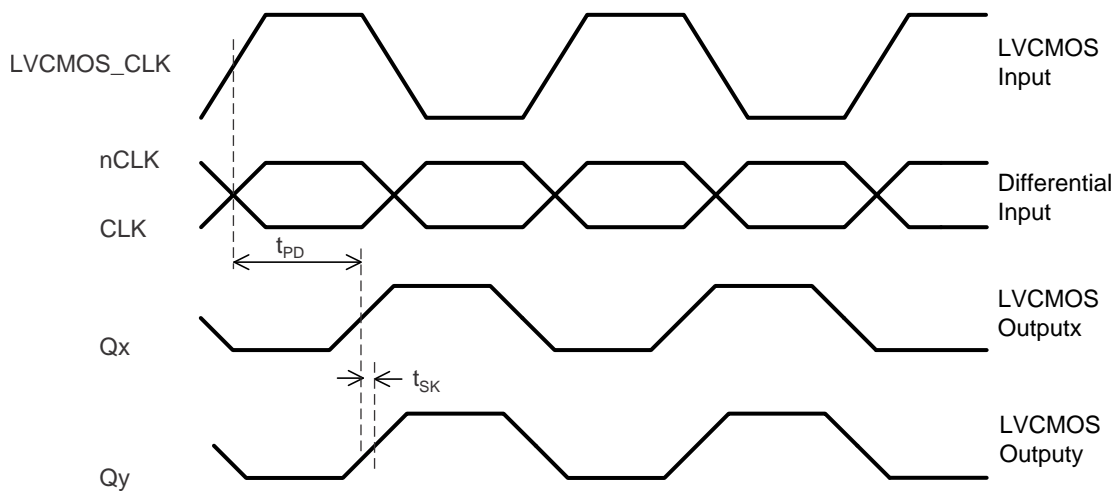

Figure 7. Output Skew and Propagation Delay

## 9 Detailed Description

### 9.1 Overview

The LMK00804B is a low skew, high performance clock fanout buffer which can distribute up to four LVCMOS/LVTTL outputs (3.3-V, 2.5-V, 1.8-V, or 1.5-V levels) from one of two selectable inputs, which can accept differential or single-ended inputs. The clock enable input is synchronized internally to eliminate runt or glitch pulses on the outputs when the clock enable terminal is asserted or de-asserted. The outputs are held in logic low state when the clock is disabled. A separate output enable terminal controls whether the outputs are active state or high-impedance state. The low additive jitter and phase noise floor, and guaranteed output and part-to-part skew characteristics make the LMK00804B ideal for applications demanding high performance and repeatability.

### 9.2 Functional Block Diagram

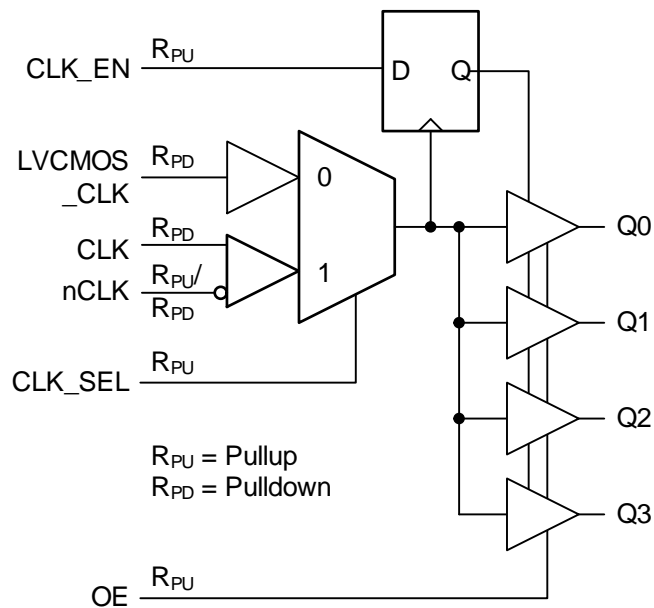

### 9.3 Feature Description

#### 9.3.1 Clock Enable Timing

After CLK\_EN switches, the clock outputs are disabled or enabled following a rising and falling input clock edge as shown in Figure 8. In the enabled mode, the output states are a function of the CLK/nCLK or LVCMOS\_CLK inputs as described in *Clock Input Function*.

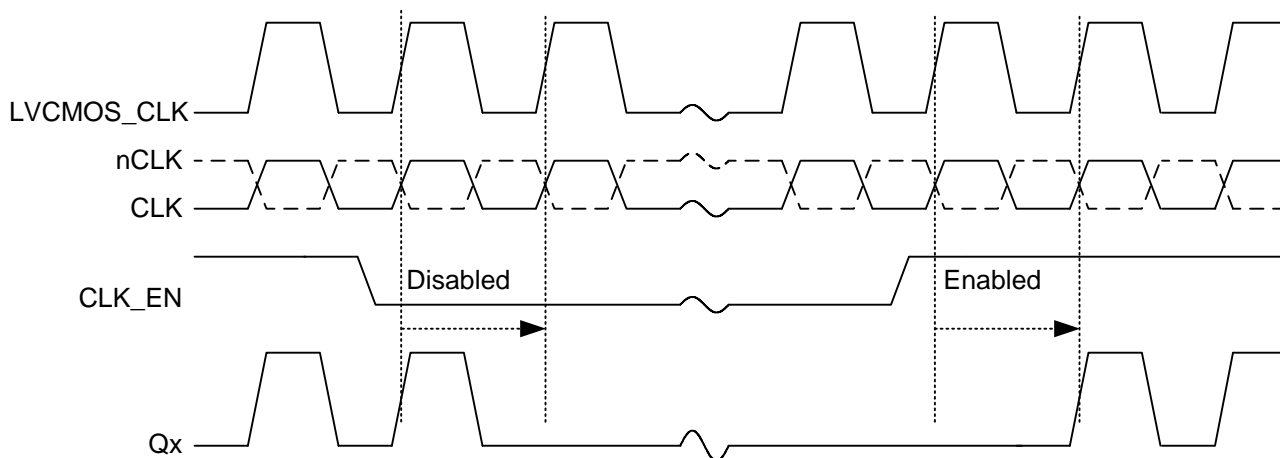

Figure 8. Clock Enable Timing Diagram

### 9.4 Device Functional Modes

The device can provide fan-out and level translation from differential or single-ended input to LVCMOS/LVTTL output, where the output VOH and VOL levels are determined by the VDDO output supply voltage and output load condition. Refer to the *Clock Input Function*.

#### 9.4.1 Clock Input Function

Table 1.

INPUTS		OUTPUTS	INPUT to OUTPUT MODE	POLARITY
CLK (or LVCMOS_CLK)	nCLK	Qx		
0	1	LOW	Differential (or Single-Ended) to Single-Ended	Non-inverting
1	0	HIGH	Differential (or Single-Ended) to Single-Ended	Non-inverting
0	Floating or Biased	LOW	Single-Ended to Single-Ended	Non-inverting
1	Floating or Biased	HIGH	Single-Ended to Single-Ended	Non-inverting
Biased	0	HIGH	Single-Ended to Single-Ended	Inverting
Biased	1	LOW	Single-Ended to Single-Ended	Inverting

## 10 Applications and Implementation

### 10.1 Application Information

Refer to the following sections for output clock and input clock interface circuits.

### 10.2 Output Clock Interface Circuit

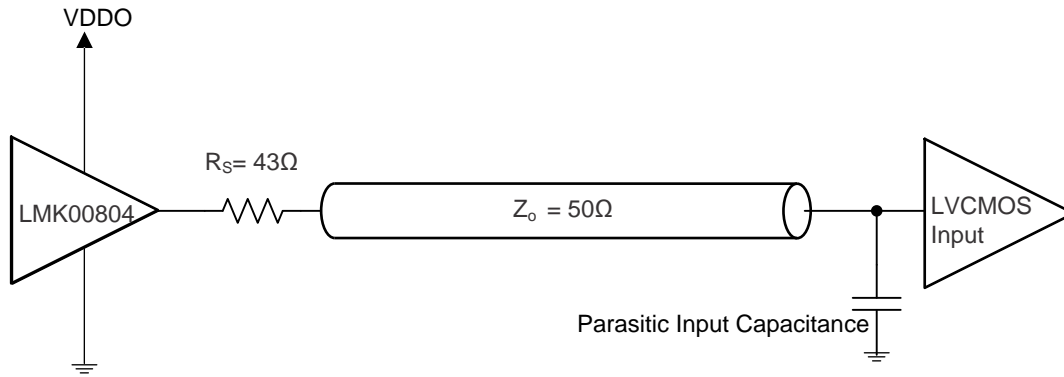

Figure 9. LVC MOS Output Configuration

### 10.3 Input Detail

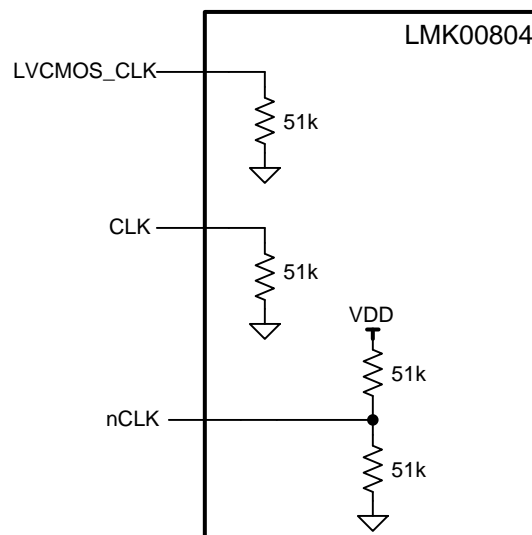

Figure 10. Clock Input Components

### 10.4 Input Clock Interface Circuits

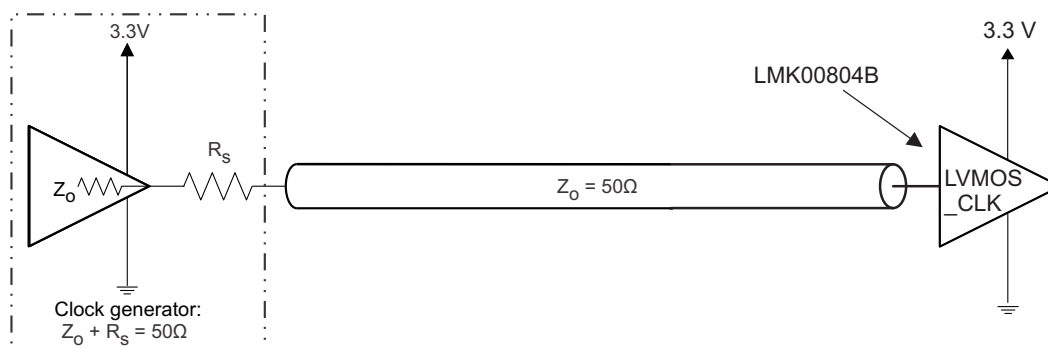
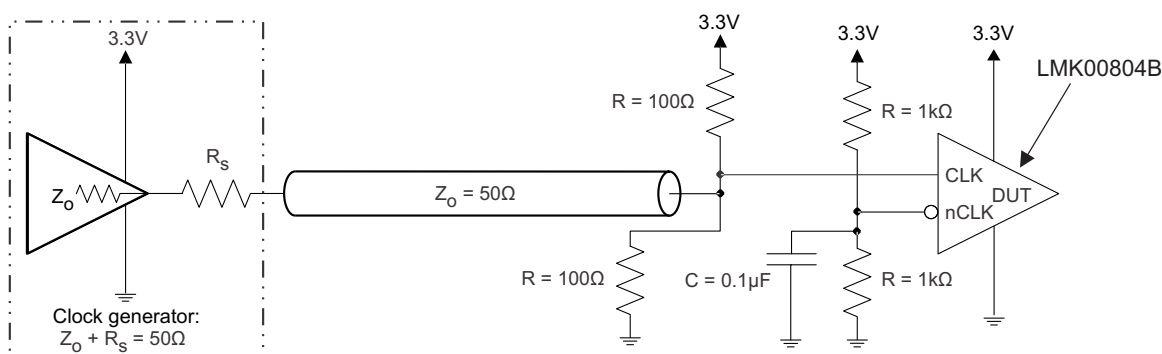

Figure 11. LVC MOS\_CLK Input Configuration



- (1) The Thevenin/split termination values ( $R = 100 \Omega$ ) at the CLK input may be adjusted to provide a small differential offset voltage (50 mV, for example) between the CLK and nCLK inputs to prevent input chatter if the LVC MOS driver is tri-stated. For example, using  $105 \Omega$  1% to 3.3 V rail and  $97.6 \Omega$  1% to GND will provide a  $-60 \text{ mV}$  offset voltage ( $V_{nCLK} - V_{CLK}$ ) and ensure a logic low state if the LVC MOS driver is tri-stated.

Figure 12. Single-Ended/LVC MOS Input DC Configuration

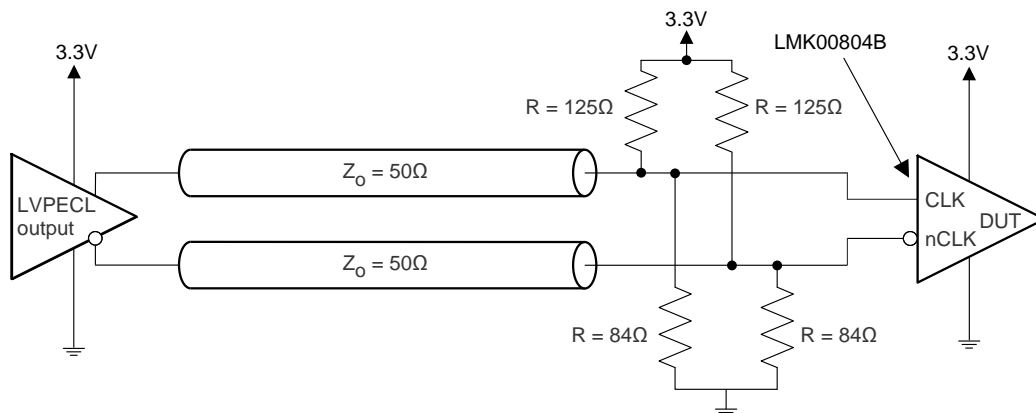
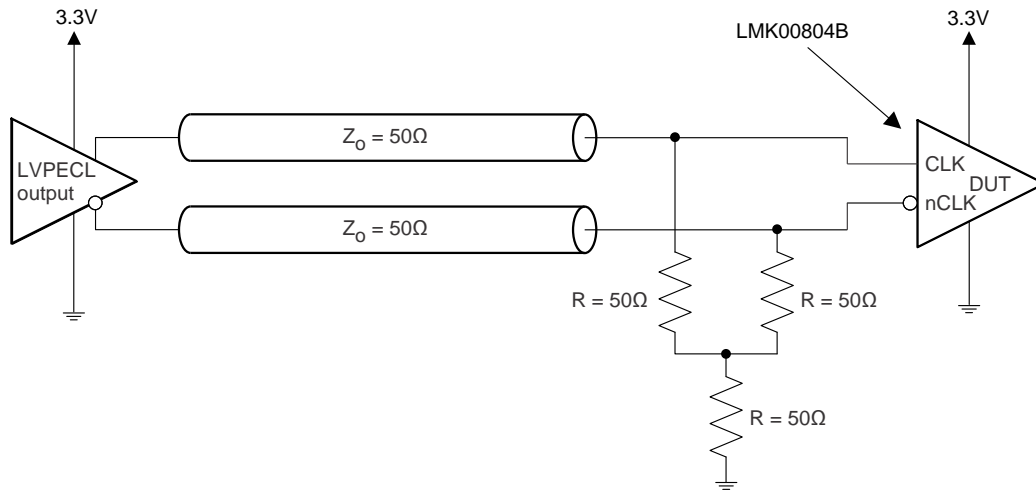
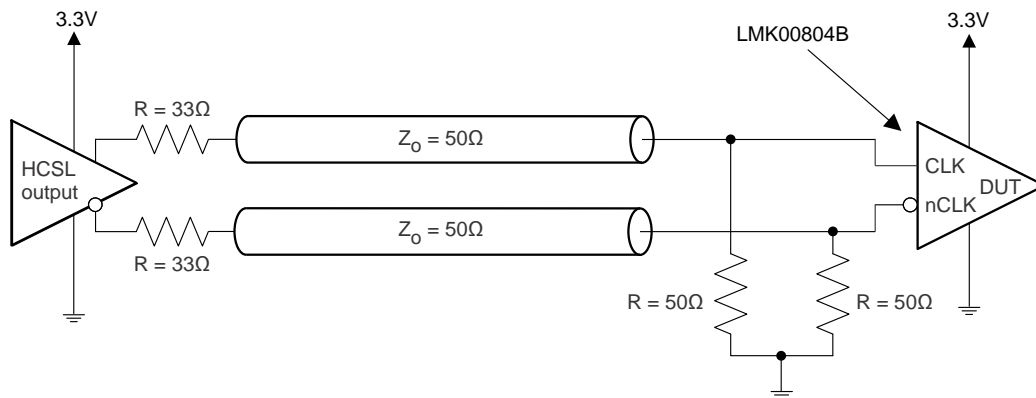
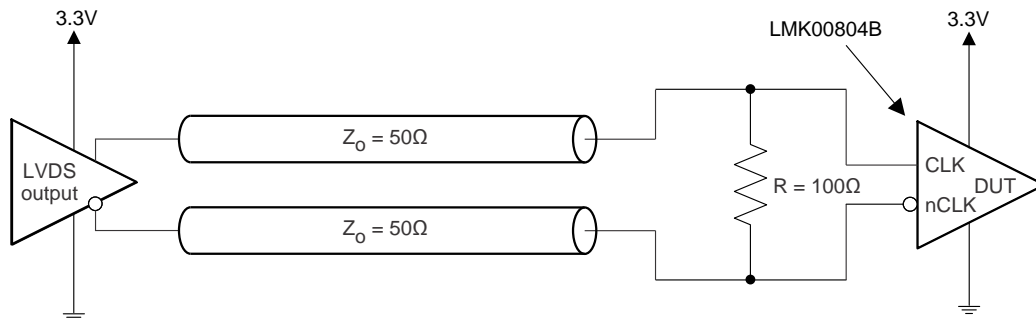

Figure 13. LVPECL Input Configuration

**Input Clock Interface Circuits (continued)**

**Figure 14. Alternative LVPECL Input Configuration**

**Figure 15. HCSL Input Configuration**

**Figure 16. LVDS Input Configuration**

Input Clock Interface Circuits (continued)

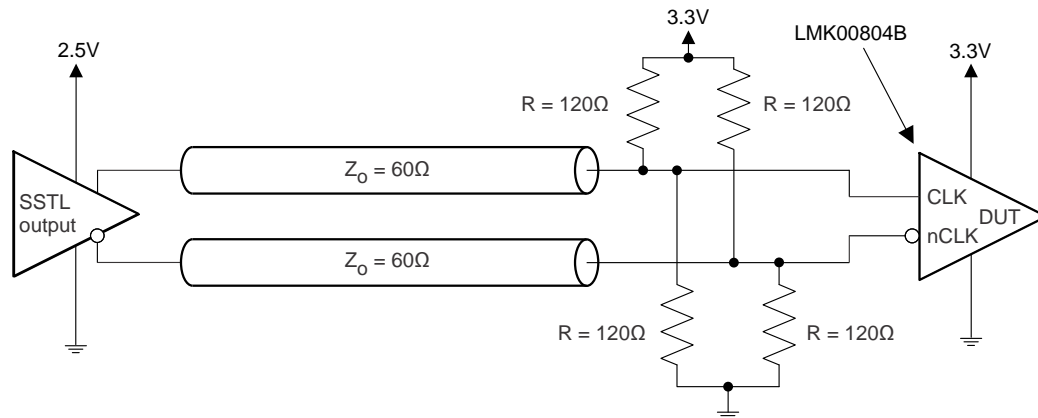

Figure 17. SSTL Input Configuration

## 10.5 Typical Applications

### 10.5.1 Design Requirements

For high-performance devices, limitations of the equipment influence phase-noise measurements. The noise floor of the equipment is often higher than the noise floor of the device. The real noise floor of the device is probably lower. It is important to understand that system-level phase noise measured at the DUT output is influenced by the input source and the measurement equipment.

For [Figure 18](#) and [Figure 19](#) system-level phase noise plots, a Rohde & Schwarz SMA100A low-noise signal generator was cascaded with an Agilent 70429A K95 single-ended to differential converter block with ultra-low phase noise and fast edge slew rate (>3 V/ns) to provide a very low-noise clock input source to the LMK00804B. An Agilent E5052 source signal analyzer with ultra-low measurement noise floor was used to measure the phase noise of the input source (SMA100A + 70429A K95) and system output (input source + LMK00804B). The input source phase noise is shown by the light yellow trace, and the system output phase noise is shown by the dark yellow trace.

### 10.5.2 Detailed Design Procedure

The additive phase noise or noise floor of the buffer ( $PN_{\text{FLOOR}}$ ) can be computed as follows:

$$PN_{\text{FLOOR}} \text{ (dBc/Hz)} = 10 \times \log_{10}[10^{(PN_{\text{SYSTEM}}/10)} - 10^{(PN_{\text{SOURCE}}/10)}]$$

where

- $PN_{\text{SYSTEM}}$  is the phase noise of the system output (source+buffer)
  - $PN_{\text{SOURCE}}$  is the phase noise of the input source
- (1)

The additive jitter of the buffer ( $J_{\text{ADD}}$ ) can be computed as follows:

$$J_{\text{ADD}} = \text{SQRT}(J_{\text{SYSTEM}}^2 - J_{\text{SOURCE}}^2)$$

where:

- $J_{\text{SYSTEM}}$  is the RMS jitter of the system output (source+buffer), integrated from 10 kHz to 20 MHz
  - $J_{\text{SOURCE}}$  is the RMS jitter of the input source, integrated from 10 kHz to 20 MHz
- (2)

Typical Applications (continued)

10.5.3 Application Curves

10.5.3.1 System-Level Phase Noise and Additive Jitter Measurement

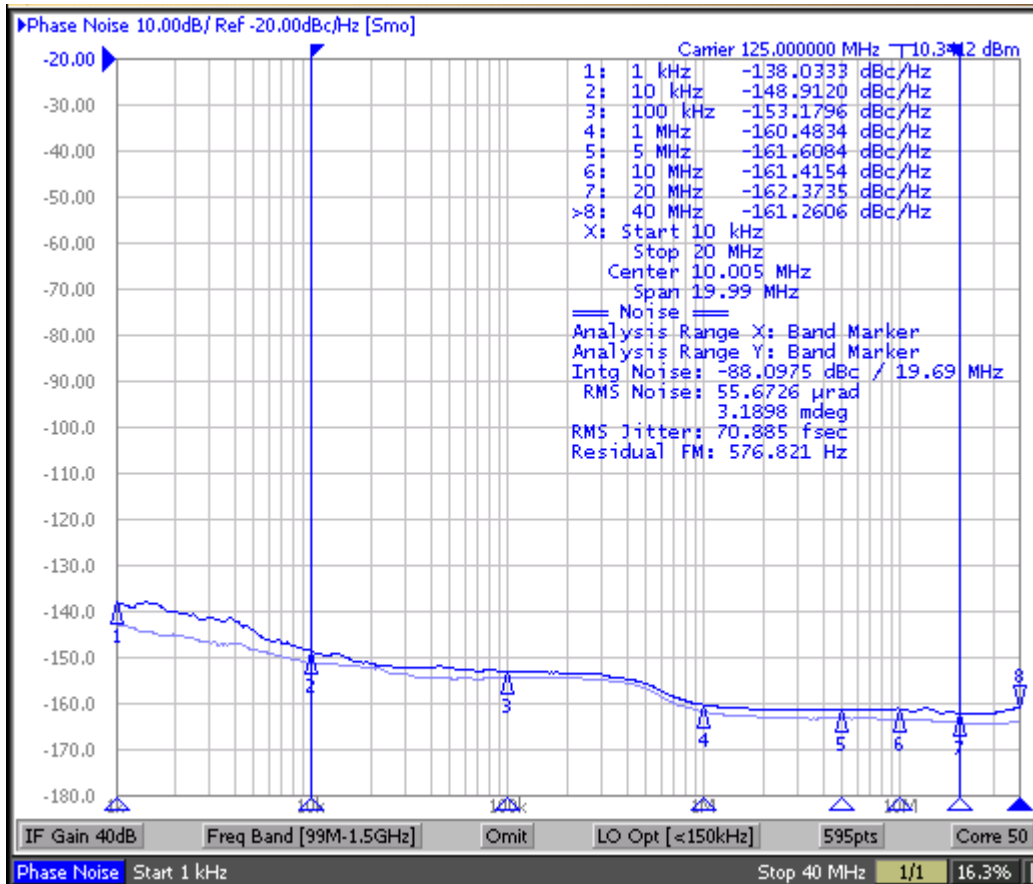

Figure 18.  
125 MHz Input Phase Noise (57 fs rms, Light Blue),  
and Output Phase Noise (71 fs rms, Dark Blue),  
Additive Jitter = 42 fs rms

Typical Applications (continued)

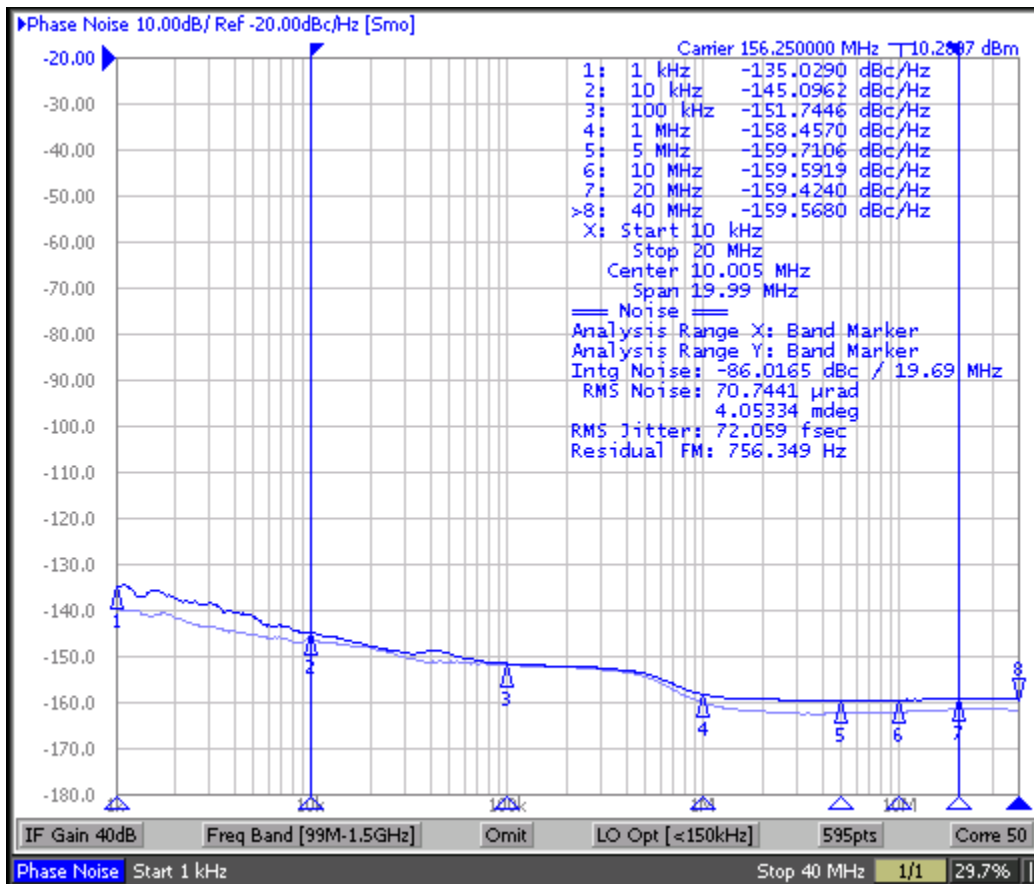

Figure 19.  
156.25 MHz Input Phase Noise (57 fs rms, Light Blue),  
and Output Phase Noise (72 fs rms, Dark Blue),  
Additive Jitter = 44 fs rms

## 10.6 Do's and Don'ts

### 10.6.1 Power Considerations

The following power consideration refers to the device-consumed power consumption only. The device power consumption is the sum of static power and dynamic power. The dynamic power usage consists of two components:

- Power used by the device as it switches states
- Power required to charge any output load

The output load can be capacitive-only or capacitive and resistive. Use the following formula to calculate the power consumption of the device:

$$P_{Dev} = P_{stat} + P_{dyn} + P_{Cload} \quad (3)$$

$$P_{stat} = (I_{DD} \times V_{DD}) + (I_{DDO} \times V_{DDO}) \quad (4)$$

$$P_{dyn} + P_{Cload} = (I_{DDO,dyn} + I_{DDO,Cload}) \times V_{DDO}$$

where:

- $I_{DDO,dyn} = C_{PD} \times V_{DDO} \times f \times n$  [mA]
  - $I_{DDO,Cload} = C_{load} \times V_{DDO} \times f \times n$  [mA]
- (5)

Example for power consumption of the LMK00804B: 4 outputs are switching,  $f = 100$  MHz,

$V_{DD} = V_{DDO} = 3.465$  V and assuming  $C_{load} = 5$  pF per output:

$$P_{Dev} = 90 \text{ mW} + 34 \text{ mW} = 124 \text{ mW} \quad (6)$$

$$P_{stat} = (21 \text{ mA} \times 3.465 \text{ V}) + (5 \text{ mA} \times 3.465 \text{ V}) = 90 \text{ mW} \quad (7)$$

$$P_{dyn} + P_{Cload} = (2.8 \text{ mA} + 6.9 \text{ mA}) \times 3.465 \text{ V} = 34 \text{ mW} \quad (8)$$

$$I_{DD,dyn} = 2 \text{ pF} \times 3.465 \text{ V} \times 100 \text{ MHz} \times 4 = 2.8 \text{ mA} \quad (9)$$

$$I_{DD,Cload} = 5 \text{ pF} \times 3.465 \text{ V} \times 100 \text{ MHz} \times 4 = 6.9 \text{ mA} \quad (10)$$

---

#### NOTE

For dimensioning the power supply, consider the total power consumption. The total power consumption is the sum of device power consumption and the power consumption of the load.

---

## Do's and Don'ts (continued)

### 10.6.2 Recommendations for Unused Input and Output Pins

- **CLK\_SEL, CLK\_EN, and OE:** These inputs all have internal pull-up ( $R_{PU}$ ) according to [Table 2](#) and can be left floating if unused. [Table 2](#) shows the default floating state of these inputs:

**Table 2. Input Floating Default States**

INPUT	FLOATING STATE SELECTION
CLK_SEL	CLK/nCLK selected
CLK_EN	Synchronous outputs enable
OE	Outputs enabled

- **CLK/nCLK Inputs:** See [Figure 10](#) for the internal connections. When using single ended input, take note of the internal pull-up and pull-down to make sure the unused input is properly biased. To interface a single-ended input to the CLK/nCLK input, the configuration shown in [Figure 12](#) is recommended.
- **LVC MOS\_CLK Input:** See [Figure 10](#) for the internal connection. The internal pull-down ( $R_{PD}$ ) resistor ensures a low state when this input is left floating.
- **Outputs:** Any unused output can be left floating with no trace connected.

### 10.6.3 Input Slew Rate Considerations

LMK00804B employs high-speed and low-latency circuit topology, allowing the device to achieve ultra-low additive jitter/phase noise and high-frequency operation. To take advantage of these benefits in the system application, it is optimal for the input signal to have a high slew rate of 3 V/ns or greater. Driving the input with a slower slew rate can degrade the additive jitter and noise floor performance. For this reason, a differential signal input is recommended over single-ended because it typically provides higher slew rate and common-mode-rejection. Refer to the “Additive Jitter vs. Input Slew Rate” plots in [Typical Characteristics](#). Also, using an input signal with very slow input slew rate, such as less than 0.05 V/ns, has the tendency to cause output switching noise to feed-back to the input stage and cause the output to chatter. This is especially true when driving either input in single-ended fashion with a very slow slew rate, such as a sine-wave input signal.

## 11 Power Supply Recommendations

### 11.1 Power Supply Considerations

While there is no strict power supply sequencing requirement, it is generally best practice to sequence the core supply voltage (VDD) before the output supply voltage (VDDO).

#### 11.1.1 Power-Supply Filtering

High-performance clock buffers are sensitive to noise on the power supply, which can dramatically increase the additive jitter of the buffer. Thus, it is essential to reduce noise from the system power supply, especially when jitter or phase noise is critical to applications.

Use of filter capacitors eliminates the low-frequency noise from power supply, where the bypass capacitors provide the very low-impedance path for high-frequency noise and guard the power-supply system against induced fluctuations. The bypass capacitors also provide instantaneous current surges as required by the device, and should have low ESR. To use the bypass capacitors properly, place them very close to the power supply terminals and lay out traces with short loops to minimize inductance. TI recommends to adding as many high-frequency (for example, 0.1  $\mu\text{F}$ ) bypass capacitors as there are supply terminals in the package. It is recommended, but not required, to insert a ferrite bead between the board power supply and the chip power supply to isolate the high-frequency switching noises generated by the clock driver, preventing them from leaking into the board supply. Choosing an appropriate ferrite bead with very low DC resistance is important, because it is imperative to provide adequate isolation between the board supply and the chip supply. It is also imperative to maintain a voltage at the supply terminals that is greater than the minimum voltage required for proper operation.

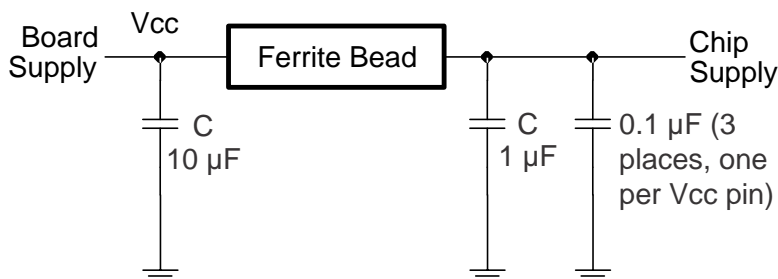

Figure 20. Power-Supply Decoupling

## Power Supply Considerations (continued)

### 11.1.2 Thermal Management

For reliability and performance reasons, limit the die temperature to a maximum of 125°C. That is, as an estimate,  $T_A$  (ambient temperature) plus device power consumption times  $\theta_{JA}$  should not exceed 125°C.

Assuming the conditions in the [Power Considerations](#) section and operating at an ambient temperature of 70°C with all outputs loaded, here is an estimate of the LMK00804B junction temperature:

$$T_J = T_A + P_{\text{Total}} \times \theta_{JA} = 70\text{ }^\circ\text{C} + (124\text{ mW} \times 116\text{ }^\circ\text{C/W}) = 70\text{ }^\circ\text{C} + 14.4\text{ }^\circ\text{C} = 84.4\text{ }^\circ\text{C} \quad (11)$$

Here are some recommendations for improving heat flow away from the die:

- Use multi-layer boards
- Specify a higher copper thickness for the board
- Increase the number of vias from the top level ground plane under and around the device to internal layers and to the bottom layer with as much copper area flow on each level as possible
- Apply air flow
- Leave unused outputs floating

## 12 Layout

### 12.1 Layout Guidelines

#### 12.1.1 Ground Planes

Solid ground planes are recommended as they provide a low-impedance return paths between the device and its bypass capacitors and its clock source and destination devices.

Avoid return paths of other system circuitry (for example, high-speed/digital logic, switching power supplies, and so forth) from passing through the local ground of the device to minimize noise coupling, which could induce added jitter and spurious noise.

#### 12.1.2 Power Supply Pins

Follow the power supply schematic and layout example described in [Power-Supply Filtering](#).

#### 12.1.3 Differential Input Termination

- Place input termination or biasing resistors as close as possible to the CLK/nCLK pins.
- Avoid or minimize vias in the 50  $\Omega$  input traces to minimize impedance discontinuities. Intra-pair skew should be also be minimized on the differential input traces.
- If not used, CLK/nCLK inputs may be left floating.

#### 12.1.4 LVCMOS Input Termination

- When the LVCMOS\_CLK input is driven from a LVCMOS driver that is series terminated to match the characteristic impedance of the trace, then input termination is not necessary; otherwise, place the input termination resistor as close as possible to the LVCMOS\_CLK input.
- Avoid or minimize vias in the 50  $\Omega$  input trace to minimize impedance discontinuities.
- If not used, LVCMOS\_CLK input may be left floating.

#### 12.1.5 Output Termination

- Place 43  $\Omega$  series termination resistors as close as possible to the Qx outputs at the launch of the 50  $\Omega$  traces.
- Avoid or minimize vias in the 50  $\Omega$  input traces to minimize impedance discontinuities.
- If not used, any Qx output should be left floating and not routed.

## 12.2 Layout Example

Please refer to the [LMK00804BEVM](#) for a layout example. A sample PCB layer is shown below.

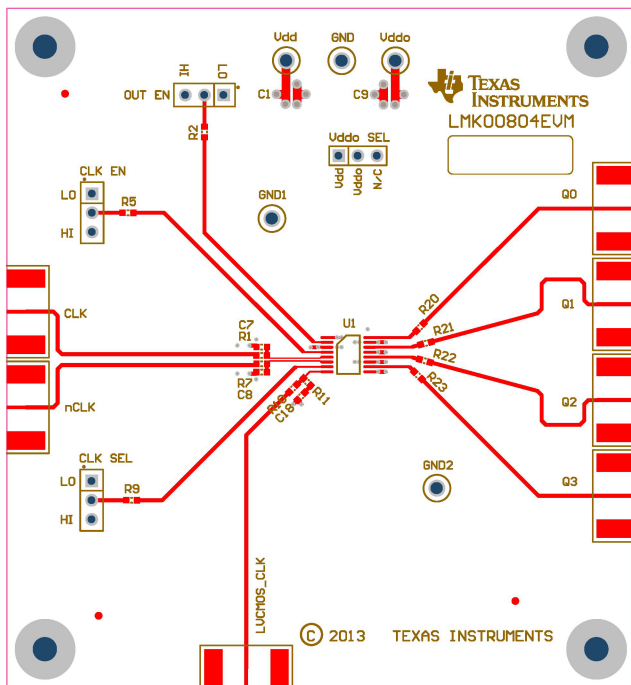

ALL ARTWORK VIEWED FROM TOP SIDE	BOARD #: SU600950	REV: A	SUN REV: Not In VersionControl
LAYER NAME = Top Overlay			
PLOT NAME = Top Layer	GENERATED : 8/29/2013 12:57:54 PM	TEXAS INSTRUMENTS	

Figure 21. Sample PCB Layout, Layer 1 (Top View)

## 13 Device and Documentation Support

### 13.1 Device Support

For device and documentation support, please direct your inquiries to the TI E2E Support Forums for Clocking Products.

### 13.2 Trademarks

All trademarks are the property of their respective owners.

### 13.3 Electrostatic Discharge Caution



These devices have limited built-in ESD protection. The leads should be shorted together or the device placed in conductive foam during storage or handling to prevent electrostatic damage to the MOS gates.

### 13.4 Glossary

[SLYZ022](#) — *TI Glossary*.

This glossary lists and explains terms, acronyms, and definitions.

## 14 Mechanical, Packaging, and Orderable Information

The following pages include mechanical packaging and orderable information. This information is the most current data available for the designated devices. This data is subject to change without notice and revision of this document. For browser-based versions of this data sheet, refer to the left-hand navigation.

**PACKAGING INFORMATION**

Orderable Device	Status (1)	Package Type	Package Drawing	Pins	Package Qty	Eco Plan (2)	Lead/Ball Finish (6)	MSL Peak Temp (3)	Op Temp (°C)	Device Marking (4/5)	Samples
LMK00804BPW	ACTIVE	TSSOP	PW	16	92	Green (RoHS & no Sb/Br)	CU SN	Level-1-260C-UNLIM	-40 to 85	K00804B	<a href="#">Samples</a>
LMK00804BPWR	ACTIVE	TSSOP	PW	16	2500	Green (RoHS & no Sb/Br)	CU SN	Level-1-260C-UNLIM	-40 to 85	K00804B	<a href="#">Samples</a>

(1) The marketing status values are defined as follows:

**ACTIVE:** Product device recommended for new designs.

**LIFEBUY:** TI has announced that the device will be discontinued, and a lifetime-buy period is in effect.

**NRND:** Not recommended for new designs. Device is in production to support existing customers, but TI does not recommend using this part in a new design.

**PREVIEW:** Device has been announced but is not in production. Samples may or may not be available.

**OBsolete:** TI has discontinued the production of the device.

(2) Eco Plan - The planned eco-friendly classification: Pb-Free (RoHS), Pb-Free (RoHS Exempt), or Green (RoHS & no Sb/Br) - please check <http://www.ti.com/productcontent> for the latest availability information and additional product content details.

**TBD:** The Pb-Free/Green conversion plan has not been defined.

**Pb-Free (RoHS):** TI's terms "Lead-Free" or "Pb-Free" mean semiconductor products that are compatible with the current RoHS requirements for all 6 substances, including the requirement that lead not exceed 0.1% by weight in homogeneous materials. Where designed to be soldered at high temperatures, TI Pb-Free products are suitable for use in specified lead-free processes.

**Pb-Free (RoHS Exempt):** This component has a RoHS exemption for either 1) lead-based flip-chip solder bumps used between the die and package, or 2) lead-based die adhesive used between the die and leadframe. The component is otherwise considered Pb-Free (RoHS compatible) as defined above.

**Green (RoHS & no Sb/Br):** TI defines "Green" to mean Pb-Free (RoHS compatible), and free of Bromine (Br) and Antimony (Sb) based flame retardants (Br or Sb do not exceed 0.1% by weight in homogeneous material)

(3) MSL, Peak Temp. - The Moisture Sensitivity Level rating according to the JEDEC industry standard classifications, and peak solder temperature.

(4) There may be additional marking, which relates to the logo, the lot trace code information, or the environmental category on the device.

(5) Multiple Device Markings will be inside parentheses. Only one Device Marking contained in parentheses and separated by a "~" will appear on a device. If a line is indented then it is a continuation of the previous line and the two combined represent the entire Device Marking for that device.

(6) Lead/Ball Finish - Orderable Devices may have multiple material finish options. Finish options are separated by a vertical ruled line. Lead/Ball Finish values may wrap to two lines if the finish value exceeds the maximum column width.

**Important Information and Disclaimer:** The information provided on this page represents TI's knowledge and belief as of the date that it is provided. TI bases its knowledge and belief on information provided by third parties, and makes no representation or warranty as to the accuracy of such information. Efforts are underway to better integrate information from third parties. TI has taken and continues to take reasonable steps to provide representative and accurate information but may not have conducted destructive testing or chemical analysis on incoming materials and chemicals. TI and TI suppliers consider certain information to be proprietary, and thus CAS numbers and other limited information may not be available for release.

In no event shall TI's liability arising out of such information exceed the total purchase price of the TI part(s) at issue in this document sold by TI to Customer on an annual basis.

**TAPE AND REEL INFORMATION**

**QUADRANT ASSIGNMENTS FOR PIN 1 ORIENTATION IN TAPE**

\*All dimensions are nominal

Device	Package Type	Package Drawing	Pins	SPQ	Reel Diameter (mm)	Reel Width W1 (mm)	A0 (mm)	B0 (mm)	K0 (mm)	P1 (mm)	W (mm)	Pin1 Quadrant
LMK00804BPWR	TSSOP	PW	16	2500	330.0	12.4	6.95	5.6	1.6	8.0	12.0	Q1

**TAPE AND REEL BOX DIMENSIONS**



\*All dimensions are nominal

Device	Package Type	Package Drawing	Pins	SPQ	Length (mm)	Width (mm)	Height (mm)
LMK00804BPWR	TSSOP	PW	16	2500	367.0	367.0	35.0

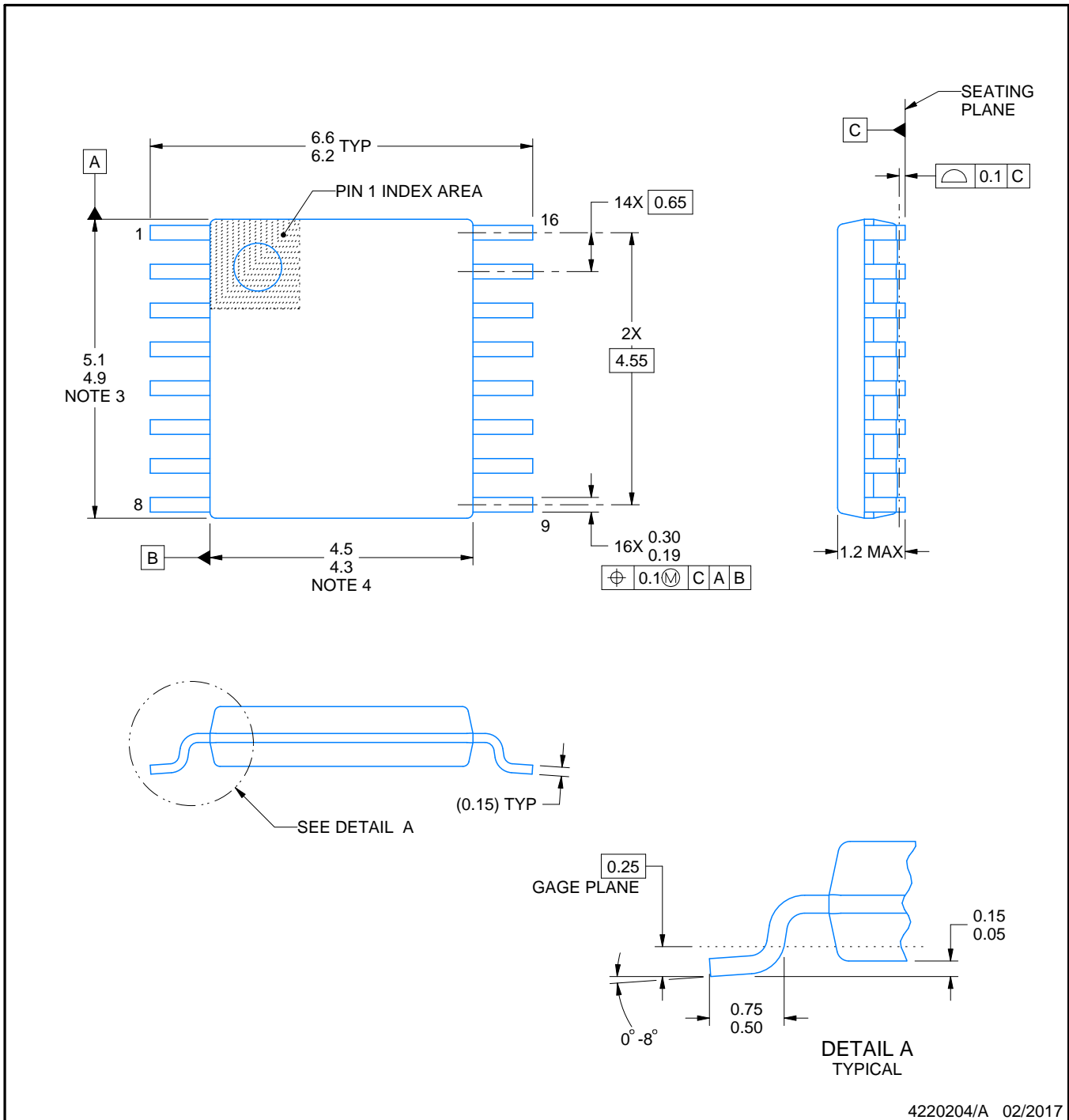

4220204/A 02/2017

NOTES:

1. All linear dimensions are in millimeters. Any dimensions in parenthesis are for reference only. Dimensioning and tolerancing per ASME Y14.5M.
2. This drawing is subject to change without notice.
3. This dimension does not include mold flash, protrusions, or gate burrs. Mold flash, protrusions, or gate burrs shall not exceed 0.15 mm per side.
4. This dimension does not include interlead flash. Interlead flash shall not exceed 0.25 mm per side.
5. Reference JEDEC registration MO-153.

# EXAMPLE BOARD LAYOUT

PW0016A

TSSOP - 1.2 mm max height

SMALL OUTLINE PACKAGE



LAND PATTERN EXAMPLE  
EXPOSED METAL SHOWN  
SCALE: 10X

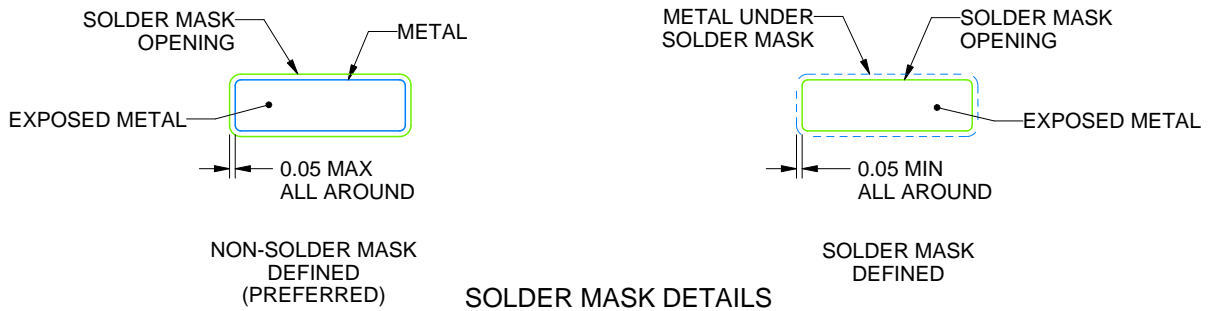

SOLDER MASK DETAILS

4220204/A 02/2017

NOTES: (continued)

- 6. Publication IPC-7351 may have alternate designs.
- 7. Solder mask tolerances between and around signal pads can vary based on board fabrication site.

# EXAMPLE STENCIL DESIGN

PW0016A

TSSOP - 1.2 mm max height

SMALL OUTLINE PACKAGE

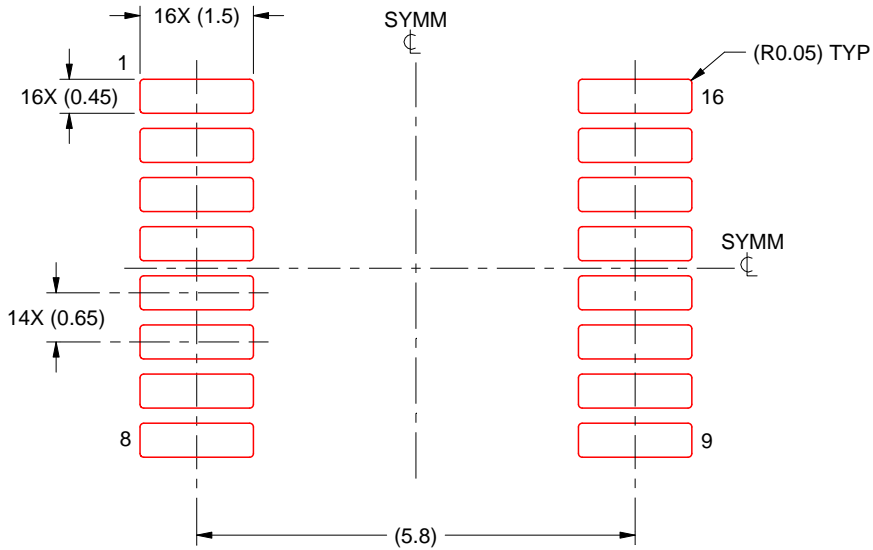

SOLDER PASTE EXAMPLE  
BASED ON 0.125 mm THICK STENCIL  
SCALE: 10X

4220204/A 02/2017

NOTES: (continued)

8. Laser cutting apertures with trapezoidal walls and rounded corners may offer better paste release. IPC-7525 may have alternate design recommendations.
9. Board assembly site may have different recommendations for stencil design.

## IMPORTANT NOTICE AND DISCLAIMER

TI PROVIDES TECHNICAL AND RELIABILITY DATA (INCLUDING DATASHEETS), DESIGN RESOURCES (INCLUDING REFERENCE DESIGNS), APPLICATION OR OTHER DESIGN ADVICE, WEB TOOLS, SAFETY INFORMATION, AND OTHER RESOURCES "AS IS" AND WITH ALL FAULTS, AND DISCLAIMS ALL WARRANTIES, EXPRESS AND IMPLIED, INCLUDING WITHOUT LIMITATION ANY IMPLIED WARRANTIES OF MERCHANTABILITY, FITNESS FOR A PARTICULAR PURPOSE OR NON-INFRINGEMENT OF THIRD PARTY INTELLECTUAL PROPERTY RIGHTS.

These resources are intended for skilled developers designing with TI products. You are solely responsible for (1) selecting the appropriate TI products for your application, (2) designing, validating and testing your application, and (3) ensuring your application meets applicable standards, and any other safety, security, or other requirements. These resources are subject to change without notice. TI grants you permission to use these resources only for development of an application that uses the TI products described in the resource. Other reproduction and display of these resources is prohibited. No license is granted to any other TI intellectual property right or to any third party intellectual property right. TI disclaims responsibility for, and you will fully indemnify TI and its representatives against, any claims, damages, costs, losses, and liabilities arising out of your use of these resources.

TI's products are provided subject to TI's Terms of Sale ([www.ti.com/legal/termsofsale.html](http://www.ti.com/legal/termsofsale.html)) or other applicable terms available either on [ti.com](http://ti.com) or provided in conjunction with such TI products. TI's provision of these resources does not expand or otherwise alter TI's applicable warranties or warranty disclaimers for TI products.

Mailing Address: Texas Instruments, Post Office Box 655303, Dallas, Texas 75265  
Copyright © 2018, Texas Instruments Incorporated

## Looking for pricing, stock, or lifecycle information?

Click below to explore more details on WIN SOURCE:

 [View LMK00804BEVM on WIN SOURCE](#)

 [Texas Instruments](#) Information

## Optimize Your Supply Chain with WIN SOURCE Solutions

-  Global Sourcing Solution
-  Obsolete Management
-  Cost Control Management
-  Shortage Management
-  Alternative Solution
-  Excess Inventory Management