



THE DATASHEET OF JZ060



2

3

4

CONFIGURATION TABLE (SEE NOTE 6.1)

PART NUMBER	C MIN [pF]	C MAX [pF]	TC [PPM/°C]	Q MIN. @ 1 MHZ	MARKING COLOR	ALTERNATE COLOR
JZ030	1.5	3.0 +50% / -0%	0 ± 200	500	BLACK	BLACK & GREEN
JZ060	2.0	6.0 +50% / -0%	0 ± 300	500	BLUE	BLUE & GREEN
JZ080	3.0	8.0 +50% / -0%	-750 ± 500	500	VIOLET	VIOLET & GREEN
JZ100	2.0	10.0 +100% / -0%	0 ± 300	500	WHITE	WHITE & GREEN
JZ150	3.0	15.0 +100% / -0%	0 ± 500	500	PINK	PINK & GREEN
JZ200	4.5	20.0 +100% / -0%	0 ± 500	500	RED	RED & GREEN
JZ300	5.5	30.0 +100% / -0%	-1500 ± 1000	200	ORANGE	ORANGE & GREEN
JZ400	8.0	40.0 +100% / -0%	-1500 ± 1000	200	YELLOW	GREEN OR YELLOW & GREEN
JZ500	8.0	50.0 +100% / -0%	-1500 ± 1000	200	GREEN	GREEN & GREEN

NOTES:

- INTERPRET DRAWING PER ANSI Y14.5M-1994.
- [ALTERNATE DIMENSIONS]** ARE IN MILLIMETERS.
- ELECTRICAL SPECIFICATIONS:
 - CAPACITANCE RANGE: *SEE CONFIGURATION TABLE.*
 - DC WORKING VOLTAGE AT MAX. RATED CAPACITANCE: 125 [VOLTS].
 - DC WITHSTANDING VOLTAGE AT MAX RATED CAPACITANCE: 220 [VOLTS].
 - Q FACTOR AT 1 [MHZ] AND MAX RATED CAPACITANCE: *SEE CONFIGURATION TABLE.*
 - INSULATION RESISTANCE: 10¹⁴ [MEGAOHMS] AT 25°C.
 - TEMPERATURE COEFFICIENT: *SEE CONFIGURATION TABLE.*
 - SELF RESONANT FREQUENCY MEASURED AT MAX RATED CAPACITANCE
- MECHANICAL SPECIFICATIONS:
 - TUNING TORQUE: 0.14 [in·oz] TO 1.00 [in·oz].
 - ALL PARTS FURNISHED ON 12 [mm] TAPE AND REEL; 1000 PIECES PER REEL.
- ENVIRONMENTAL:
 - OPERATING TEMPERATURE: -40°C TO +85°C.
 - RoHS COMPLIANT.
- MISCELLANEOUS:
 - IN ORDER TO PROVIDE THE HIGHEST LEVELS OF SERVICE, KNOWLES RESERVES THE RIGHT TO SUPPLY EQUIVALENT PRODUCTS WHERE SPECIFICATIONS ARE EQUIVALENT OR ENHANCED. THIS INCLUDES SUBSTITUTION OF JZ500 TO JZ400 AND HV SUFFIX FOR STANDARDS PARTS.



1. INTERPRET DRAWING PER ANSI Y14.5M-1994.

2. [ALTERNATE DIMENSIONS] ARE IN MILLIMETERS.

3. ELECTRICAL SPECIFICATIONS:

3.1. CAPACITANCE RANGE: SEE CONFIGURATION TABLE.

3.2. DC WORKING VOLTAGE AT MAX. RATED CAPACITANCE: 125 [VOLTS].

3.3. DC WITHSTANDING VOLTAGE AT MAX RATED CAPACITANCE: 220 [VOLTS].

3.4. Q FACTOR AT 1 [MHZ] AND MAX RATED CAPACITANCE: SEE CONFIGURATION TABLE.

3.5. INSULATION RESISTANCE: 10^14 [MEGAOHMS] AT 25°C.

3.6. TEMPERATURE COEFFICIENT: SEE CONFIGURATION TABLE.

3.7. SELF RESONANT FREQUENCY MEASURED AT MAX RATED CAPACITANCE

4. MECHANICAL SPECIFICATIONS:

4.1. TUNING TORQUE: 0.14 [in·oz] TO 1.00 [in·oz].

4.2. ALL PARTS FURNISHED ON 12 [mm] TAPE AND REEL; 1000 PIECES PER REEL.

5. ENVIRONMENTAL:

5.1. OPERATING TEMPERATURE: -40°C TO +85°C.

5.2. RoHS COMPLIANT.

6. MISCELLANEOUS:

6.1. IN ORDER TO PROVIDE THE HIGHEST LEVELS OF SERVICE, KNOWLES RESERVES THE RIGHT TO SUPPLY EQUIVALENT PRODUCTS WHERE SPECIFICATIONS ARE EQUIVALENT OR ENHANCED.

THIS INCLUDES SUBSTITUTION OF JZ500 TO JZ400 AND HV SUFFIX FOR STANDARDS PARTS.

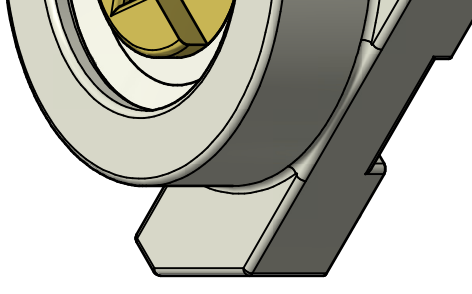

ISO VIEW
SCALE 20 : 1

"VOLTAGE CLASS" VERSION ID DOT NORMALLY LEFT UNPAINTED FOR STANDARD VOLTAGE PARTS. YELLOW-GREEN COLOR DOT TO BE PRESENT IF SUBSTITUTED BY ENHANCED HV PART. **SEE NOTE 6.1**

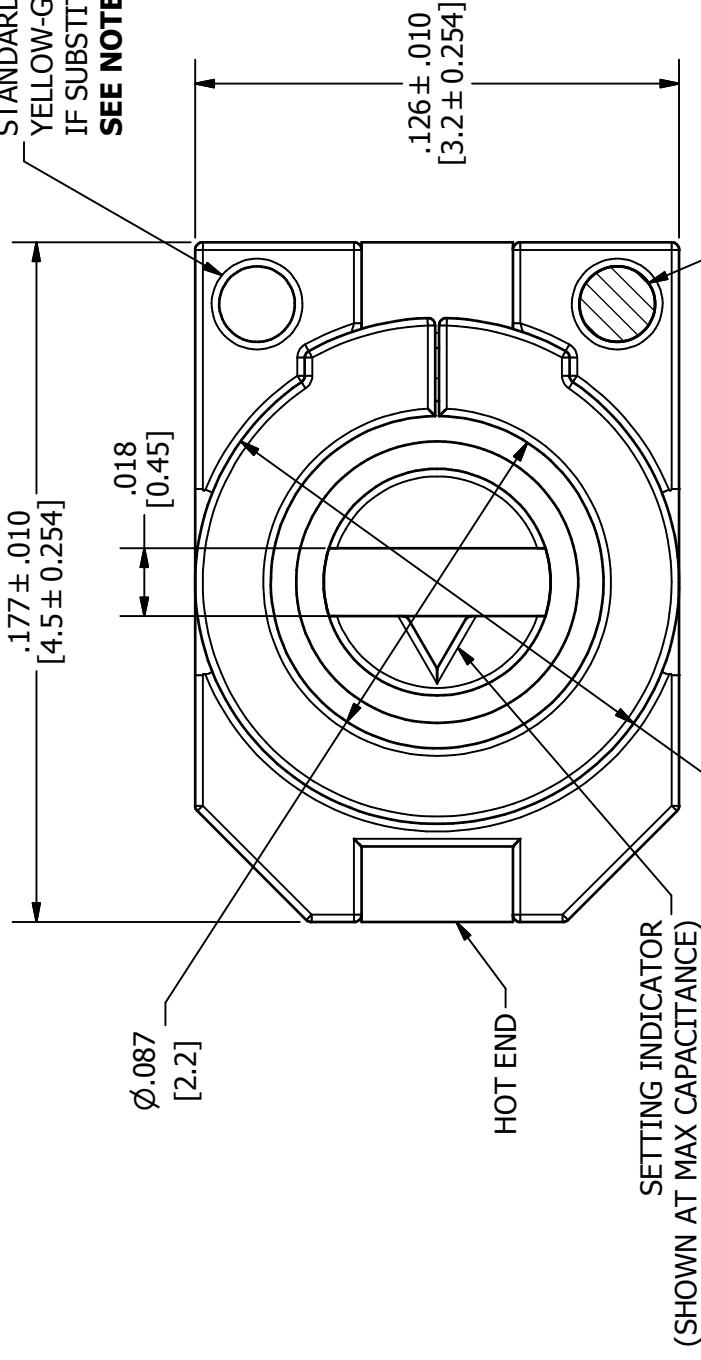

MAIN VIEW
SCALE 20 : 1

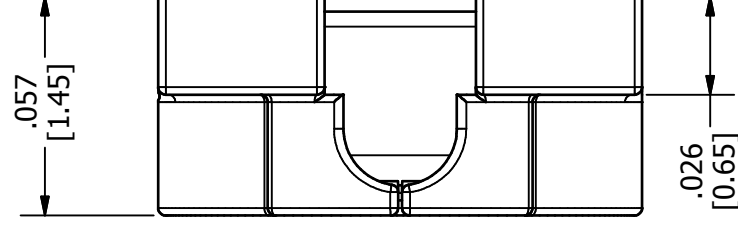

COLD (ROTOR) TERMINAL

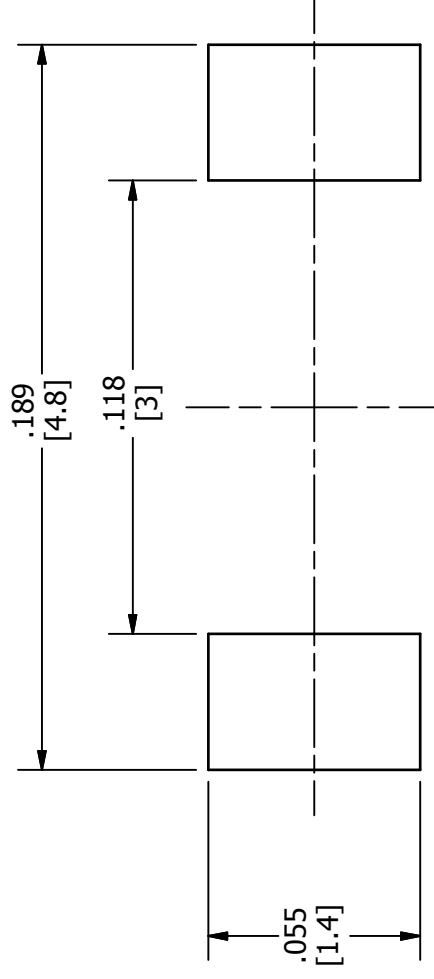
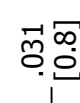

SUGGESTED FOOTPRINT
SOLDER PASTE THICKNESS OF 0.15 [mm] RECOMMENDED
SCALE 20 : 1

ECO #	ZONE	REV	DESCRIPTION
1392	ALL	C	JZ500 ADDED; UPDATED TO CURRENT SPECIFICATIONS
1474	TAG	E	NOTE 6.1 ADDED. SUBSTITUTION SPECIFICATIONS MATCHED TO CURRENT SALES
1607	TAG	F	SPECS MATCHED TO CURRENT SALES

MATERIAL	N/A	DRAWN	11/26/2013	DLI • Novatec
FINISH <td>N/A <td>E. CONTRERAS <td>12/10/2014 <td></td> </td></td></td>	N/A <td>E. CONTRERAS <td>12/10/2014 <td></td> </td></td>	E. CONTRERAS <td>12/10/2014 <td></td> </td>	12/10/2014 <td></td>	
TOLERANCES	SURFACE FINISH 32 .XX ± .XXX ±.008 .XXXX ± X°±1° X,X°±0.1°	CHECKED	12/12/2014	
3RD ANGLE PROJECTION		T. BYRNE	12/1/2014	
		G. SATTERFIELD	12/4/2014	
		F. KHALIFEH		
		ENGINEERING		
		T. DOLAN		
		CUSTOMER PART NUMBER		
		INVENTOR 2013 GENERATED DWG		



OUTLINE

SIZE	C
SCALE	1

2

3

4

2 3 4

HANDLING/STORAGE PRECAUTIONS:

- i.- DO NOT USE FLOW SOLDERING.
- ii.- DO NOT APPLY SOLDER OR FLUX TO ANY PART OF THE PRODUCT WHEN USING SOLDERING IRON, THE SOLDERING IRON SHOULD BE KEPT IN CONTACT WITH THE HOUSING OF THE PRODUCT.
- iii.- IN CONTACT WITH THE HOUSING OF THE PRODUCT.
- iv.- PLEASE REFER TO SOLDER RECOMMENDATIONS FOR THE PRODUCT.
- v.- NO-CLEAN METHOD IS PREFERRED OVER CLEANING AGENTS.
- vi.- DO NOT APPLY LOCKING SPRAY OR PAINT TO THE PRODUCT.
- vii.- ELECTRIC SPECIFICATIONS MAY BE AFFECTED BY THE USE OF PRODUCT SOLDERABILITY.
- viii.- USE OF CERAMIC SCREWDRIVERS IS RECOMMENDED.
- ix.- DO NOT APPLY AXIAL LOAD DURING TUNING.
- x.- KEEP PARTS OUT OF DIRECT SUNLIGHT EXPOSURE.

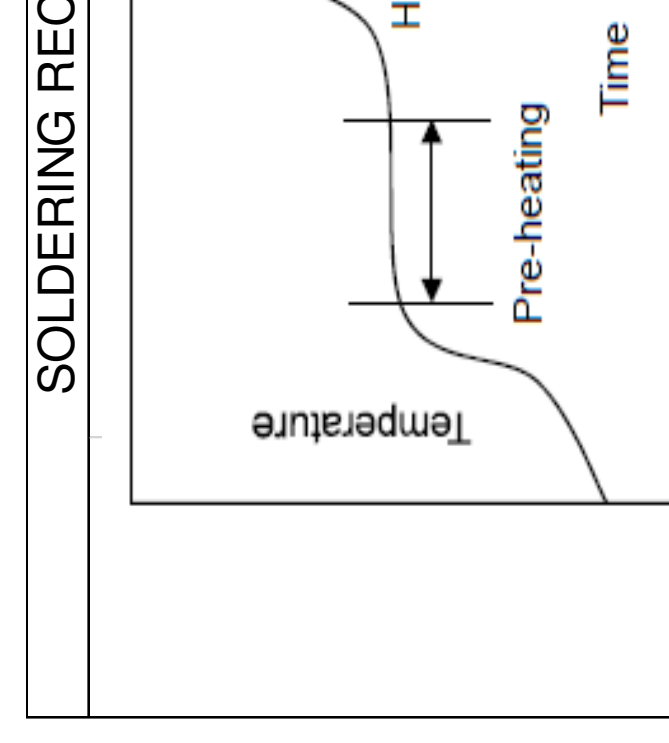
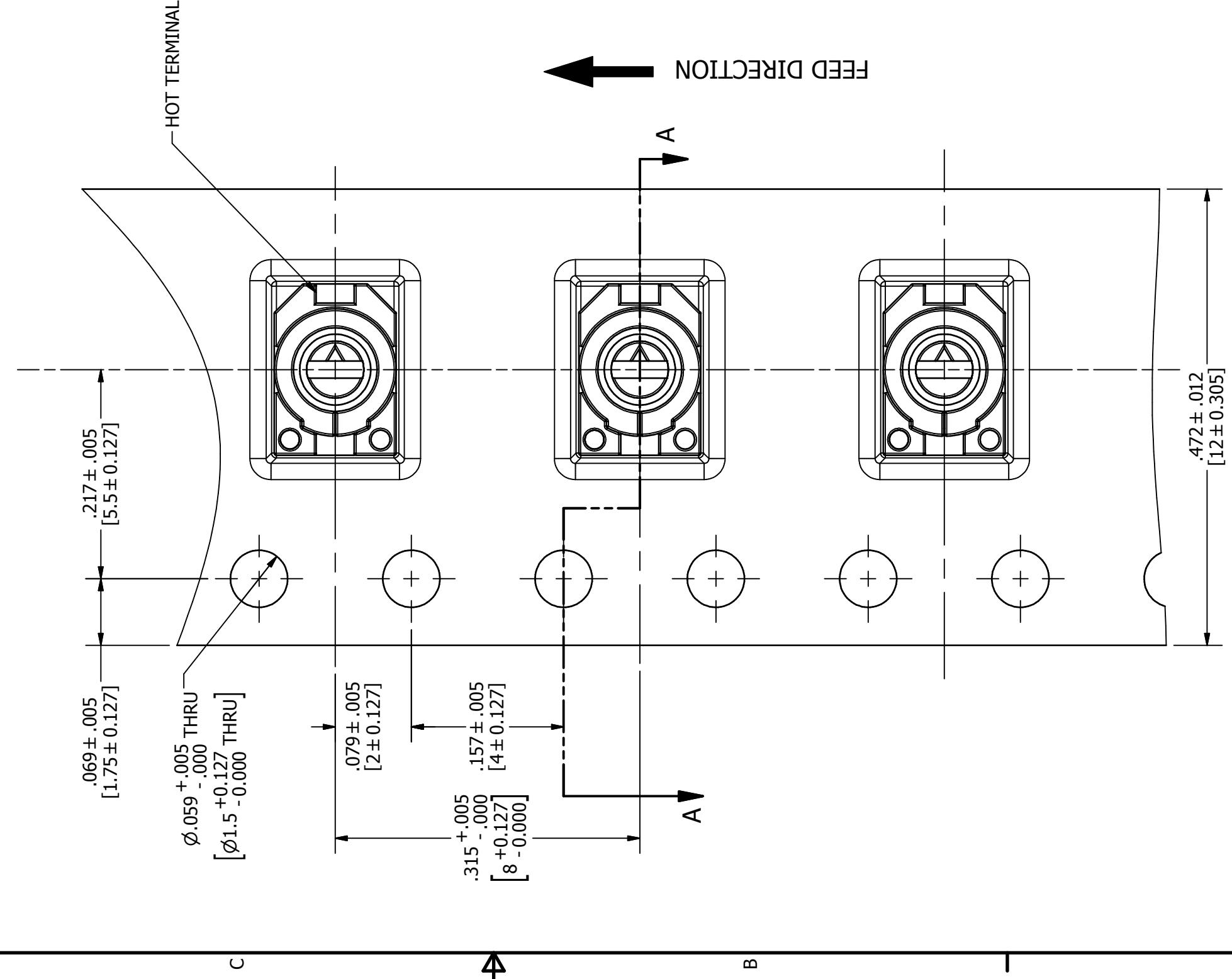
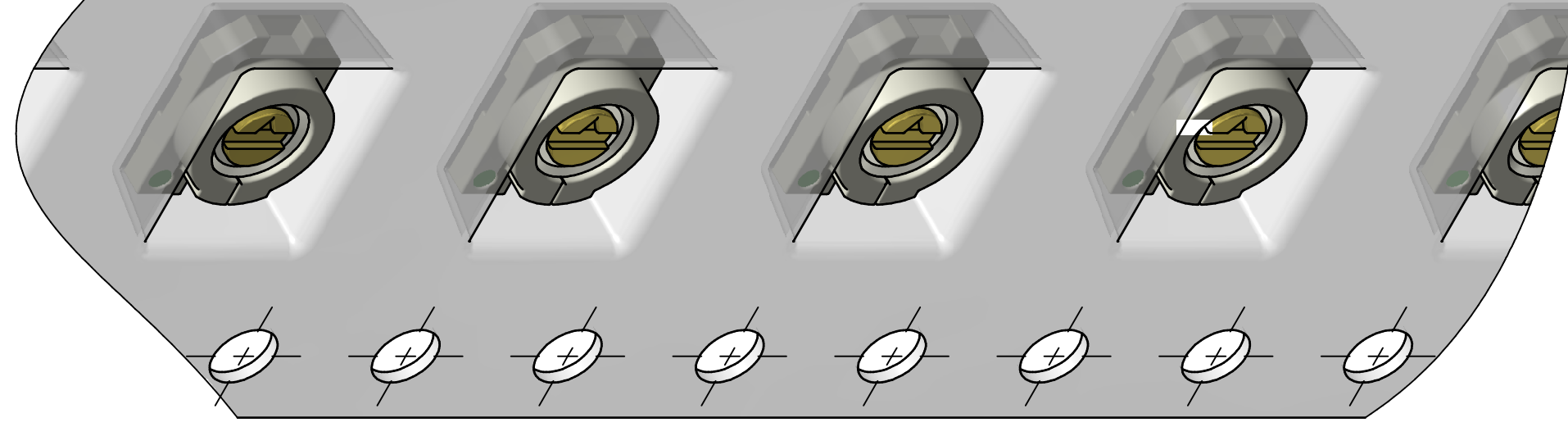
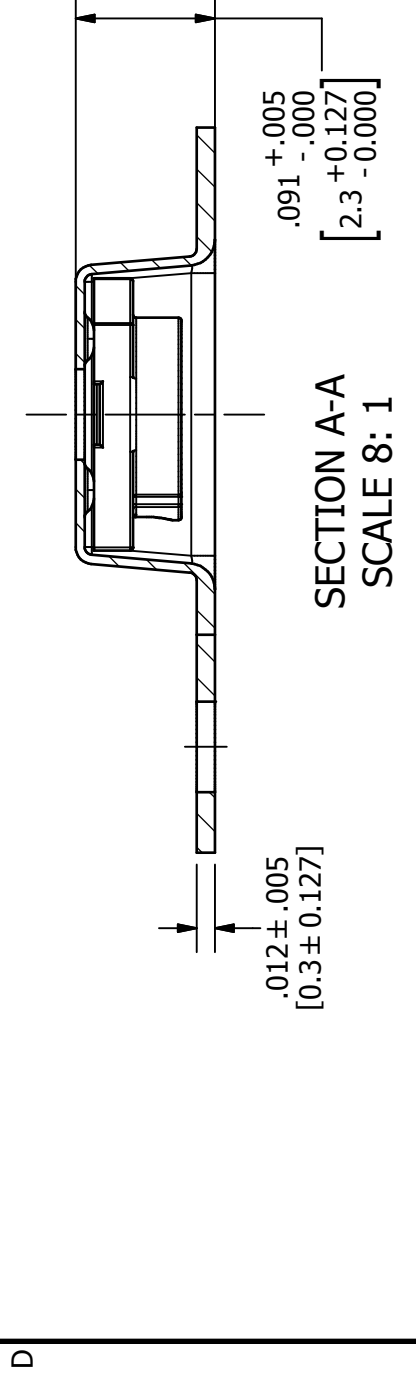

STANDARD LEAD-FREE	
STAGE	SAC305 SOLDER
PRE-HEATING	TEMPERATURE: 150[°C] - TIME: 60 - 120 SECONDS
HEATING	TEMPERATURE: 220[°C] - TIME: 30 - 60 SECONDS
PEAK HEAT	TEMPERATURE: 265[°C] - TIME: 3 SECONDS MAX
REFLOW CYCLES	2 TIMES MAX
SPEC	SOLDER TEMPERATURE 400[°C] - TIME: 3 SECONDS MAX

CARRIER TAPE DETAIL
SCALE 8: 1

DLI • Novatec
SIZE CA 1
SCALE

2 3 4

Looking for pricing, stock, or lifecycle information?

Click below to explore more details on WIN SOURCE:

- [View JZ060 on WIN SOURCE](#)
- [Knowles Voltronics Information](#)

Optimize Your Supply Chain with WIN SOURCE Solutions

- ✓ Global Sourcing Solution
- ✓ Obsolete Management
- ✓ Cost Control Management
- ✓ Shortage Management
- ✓ Alternative Solution
- ✓ Excess Inventory Management