

## Features

- **SuperWIDE HIGH-DENSITY IN-SYSTEM PROGRAMMABLE LOGIC**
  - 3.3V Power Supply
  - User Selectable 3.3V/2.5V I/O
  - 24000 PLD Gates / 512 Macrocells
  - Up to 288 I/O Pins
  - 512 Registers
  - High-Speed Global Interconnect
  - SuperWIDE 32 Generic Logic Block (GLB) Size for Optimum Performance
  - SuperWIDE Input Gating (68 Inputs) for Fast Counters, State Machines, Address Decoders, etc.
  - PCB Efficient Ball Grid Array (BGA) Package Options
  - Interfaces with Standard 5V TTL Devices
- **HIGH PERFORMANCE E<sup>2</sup>CMOS<sup>®</sup> TECHNOLOGY**
  - $f_{max} = 110$  MHz Maximum Operating Frequency
  - $t_{pd} = 8.5$  ns Propagation Delay
  - Enhanced  $t_{su2} = 7$  ns,  $t_{su3} (CLK0/1) = 4.5$  ns,  $t_{su3} (CLK2/3) = 3.5$  ns
  - TTL/3.3V/2.5V Compatible Input Thresholds and Output Levels
  - Electrically Erasable and Reprogrammable
  - Non-Volatile
  - Programmable Speed/Power Logic Path Optimization
- **IN-SYSTEM PROGRAMMABLE**
  - Increased Manufacturing Yields, Reduced Time-to-Market, and Improved Product Quality
  - Reprogram Soldered Devices for Faster Debugging
- **100% IEEE 1149.1 BOUNDARY SCAN TESTABLE AND 3.3V IN-SYSTEM PROGRAMMABLE**
- **ARCHITECTURE FEATURES**
  - Enhanced Pin-Locking Architecture with Single-Level Global Routing Pool and SuperWIDE GLBs
  - Wrap Around Product Term Sharing Array Supports up to 35 Product Terms Per Macrocell
  - Macrocells Support Concurrent Combinatorial and Registered Functions
  - Macrocell Registers Feature Multiple Control Options Including Set, Reset and Clock Enable
  - Four Dedicated Clock Input Pins Plus Macrocell Product Term Clocks
  - Slew and Skew Programmable I/O (SASPI/O) Supports Programmable Bus Hold, Pull-up, Open Drain and Slew and Skew Rate Options
  - Six Global Output Enable Terms, Two Global OE Pins and One Product Term OE per Macrocell

## Functional Block Diagram

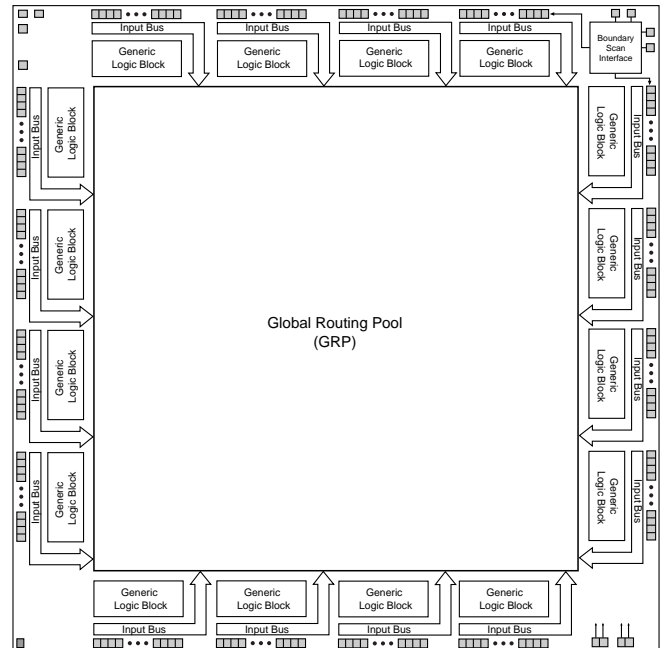

## ispLSI 5000V Description

The ispLSI 5000V Family of In-System Programmable High Density Logic Devices is based on Generic Logic Blocks (GLBs) of 32 registered macrocells and a single Global Routing Pool (GRP) structure interconnecting the GLBs.

Outputs from the GLBs drive the Global Routing Pool (GRP) between the GLBs. Switching resources are provided to allow signals in the Global Routing Pool to drive any or all the GLBs in the device. This mechanism allows fast, efficient connections across the entire device.

Each GLB contains 32 macrocells and a fully populated, programmable AND-array with 160 logic product terms and five extra control product terms. The GLB has 68 inputs from the Global Routing Pool which are available in both true and complement form for every product term. The 160 product terms are grouped in 32 sets of five and sent into a Product Term Sharing Array (PTSA) which allows sharing up to a maximum of 35 product terms for a single function. Alternatively, the PTSA can be bypassed for functions of five product terms or less. The

**Functional Block Diagram**

**Figure 1. ispLSI 5512VA Functional Block Diagram (388 BGA Option)**

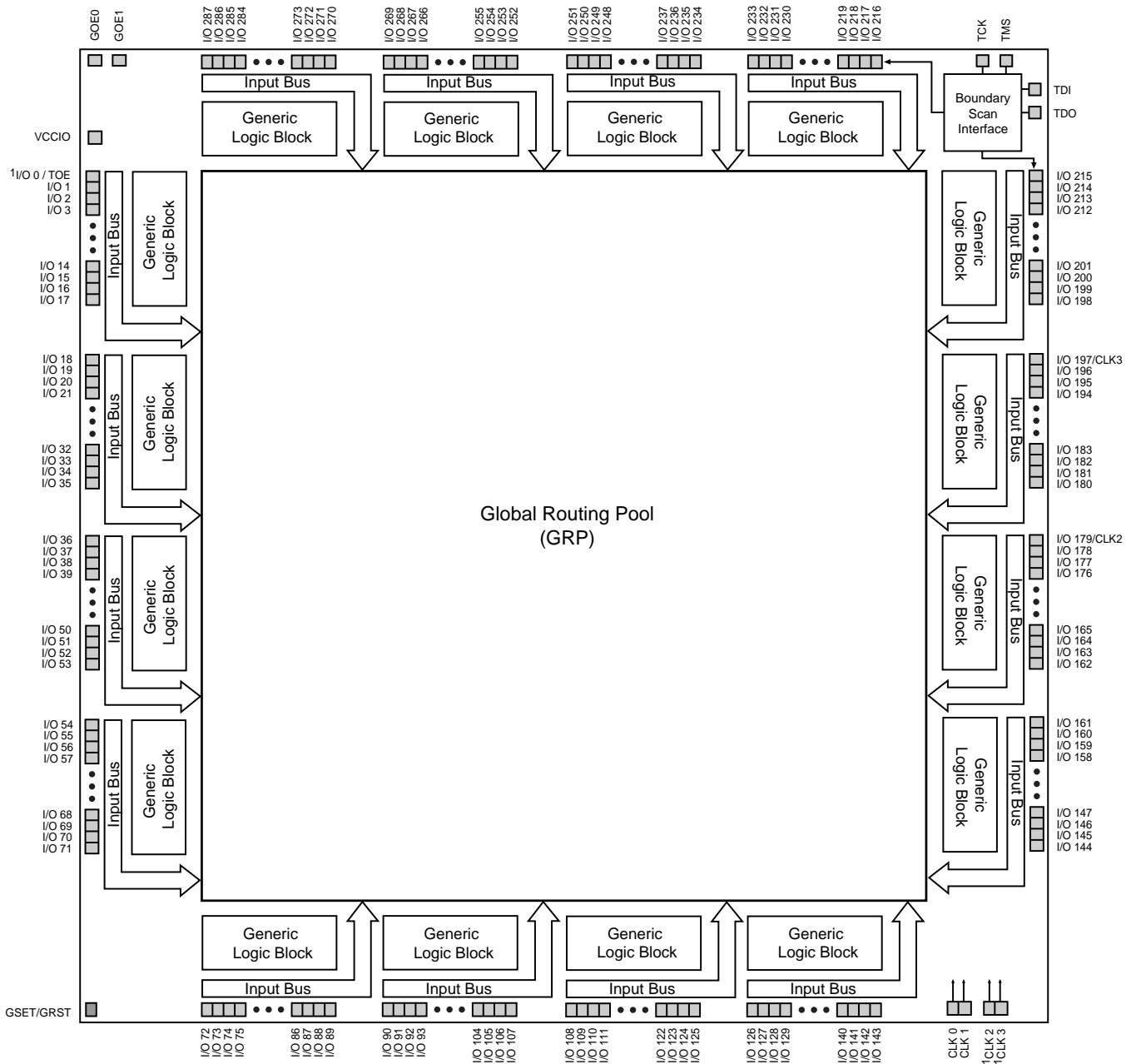

1. CLK2, CLK3 and TOE signals are multiplexed with I/O signals. Which I/O is multiplexed is determined by the package type used – see table below.

Package Type	Multiplexed Signals		
388 BGA	I/O 179 / CLK2	I/O 197 / CLK3	I/O 0 / TOE
272 BGA	I/O 119 / CLK2	I/O 131 / CLK 3	I/O 0 / TOE
208 PQFP	I/O 89 / CLK2	I/O 98 / CLK 3	I/O 0 / TOE

## ispLSI 5000V Description (Continued)

five extra product terms are used for shared GLB controls, set, reset, clock, clock enable and output enable.

The 32 registered macrocells in the GLB are driven by the 32 outputs from the PTSA or the PTSA bypass. Each macrocell contains a programmable XOR gate, a programmable register/latch/toggle flip-flop and the necessary clocks and control logic to allow combinatorial or registered operation. The macrocells each have two outputs, which can be fed back through the Global Routing Pool. This dual output capability from the macrocell allows efficient use of the hardware resources. One output can be a registered function for example, while the other output can be an unrelated combinatorial function. A direct register input from the I/O pad facilitates efficient use of this feature to construct high-speed input registers.

Macrocell registers can be clocked from one of several global or product term clocks available on the device. A global and product term clock enable is also provided, eliminating the need to gate the clock to the macrocell registers. Reset and preset for the macrocell register is provided from both global and product term signals. The macrocell register can be programmed to operate as a D-type register, a D-type latch or a T-type flip flop.

The 32 outputs from the GLB can drive both the Global Routing Pool and the device I/O cells. The Global Routing Pool contains one line from each macrocell output and one line from each I/O pin.

The input buffer threshold has programmable TTL/3.3V/2.5V compatible levels. The output driver can source 4mA and sink 8mA in 3.3V mode. The output drivers have a separate VCCIO reference input which is independent of the main VCC supply for the device. This feature allows the output drivers to drive either 3.3V or 2.5V output levels while the device logic and the output current drive

is always powered from 3.3V. The output drivers also provide individually programmable edge rates and open drain capability. A programmable pullup resistor is provided to tie off unused inputs and a programmable bus-hold latch is available to hold tristate outputs in their last valid state until the bus is driven again by some device.

The ispLSI 5000V Family features 3.3V, non-volatile in-system programmability for both the logic and the interconnect structures, providing the means to develop truly reconfigurable systems. Programming is achieved through the industry standard IEEE 1149.1-compliant Boundary Scan interface. Boundary Scan test is also supported through the same interface.

An enhanced, multiple cell security scheme is provided that prevents reading of the JEDEC programming file when secured. After the device has been secured using this mechanism, the only way to clear the security is to execute a bulk-erase instruction.

## ispLSI 5000V Family Members

The ispLSI 5000V Family ranges from 256 macrocells to 512 macrocells and operates from a 3.3V power supply. All family members will be available with multiple package options. The ispLSI 5000V Family device matrix showing the various bondout options is shown in the table below.

The interconnect structure (GRP) is very similar to Lattice's existing ispLSI 1000, 2000 and 3000 families, but with an enhanced interconnect structure for optimal pin locking and logic routing. This eliminates the need for registered I/O cells or an Output Routing Pool.

**Table 1. ispLSI 5000VA Family**

Device	GLBs	Macrocells	Package Type			
			208 fpBGA	208 PQFP	272 BGA	388 BGA
ispLSI 5256VA	8	256	144 I/O	144 I/O	192 I/O	—
ispLSI 5384VA	12	384	144 I/O	144 I/O	192 I/O	288 I/O
ispLSI 5512VA	16	512	—	144 I/O	192 I/O	288 I/O

Figure 2. ispLSI 5512VA Block Diagram (288 I/O Version)

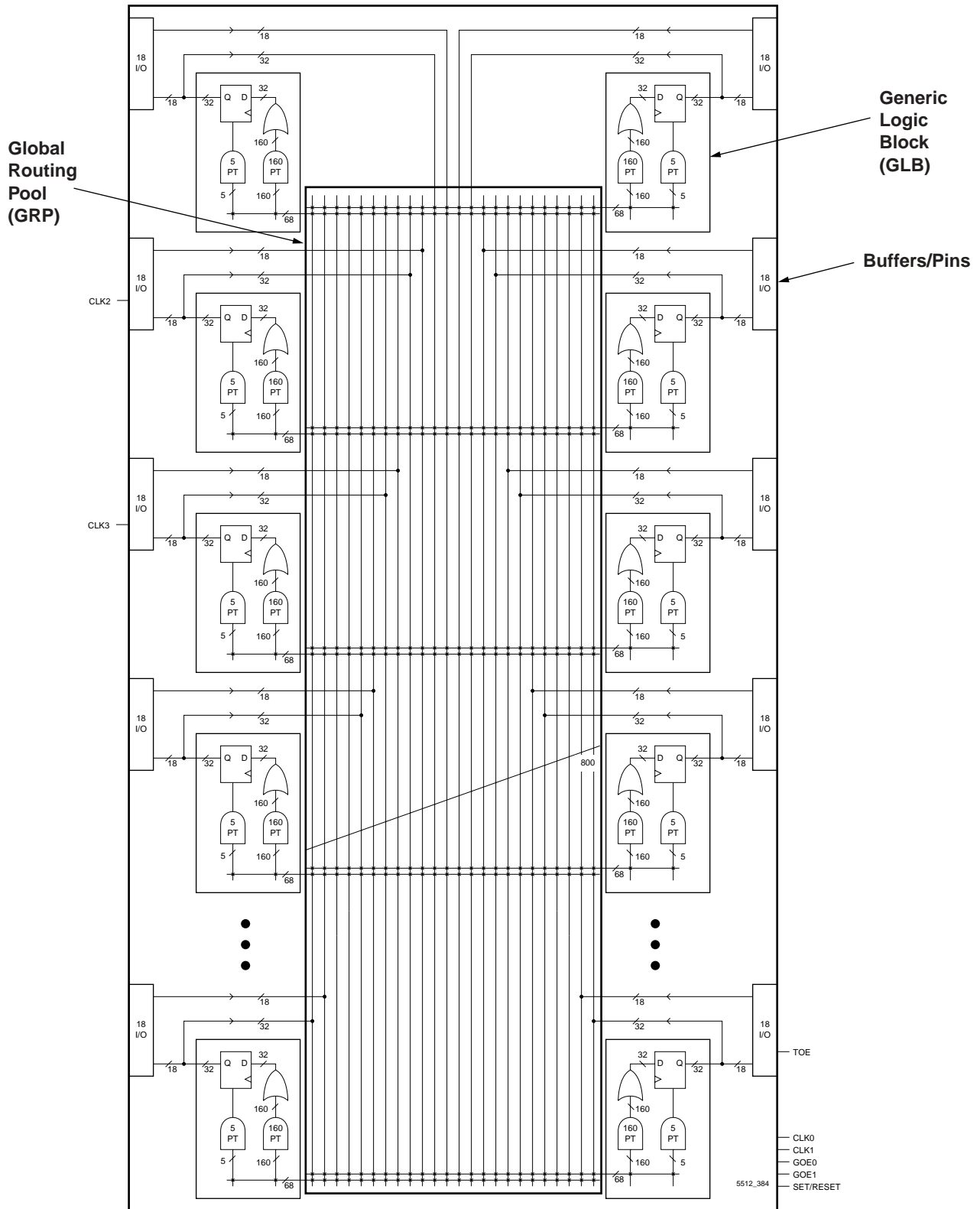

Figure 3. ispLSI 5000V Generic Logic Block (GLB)

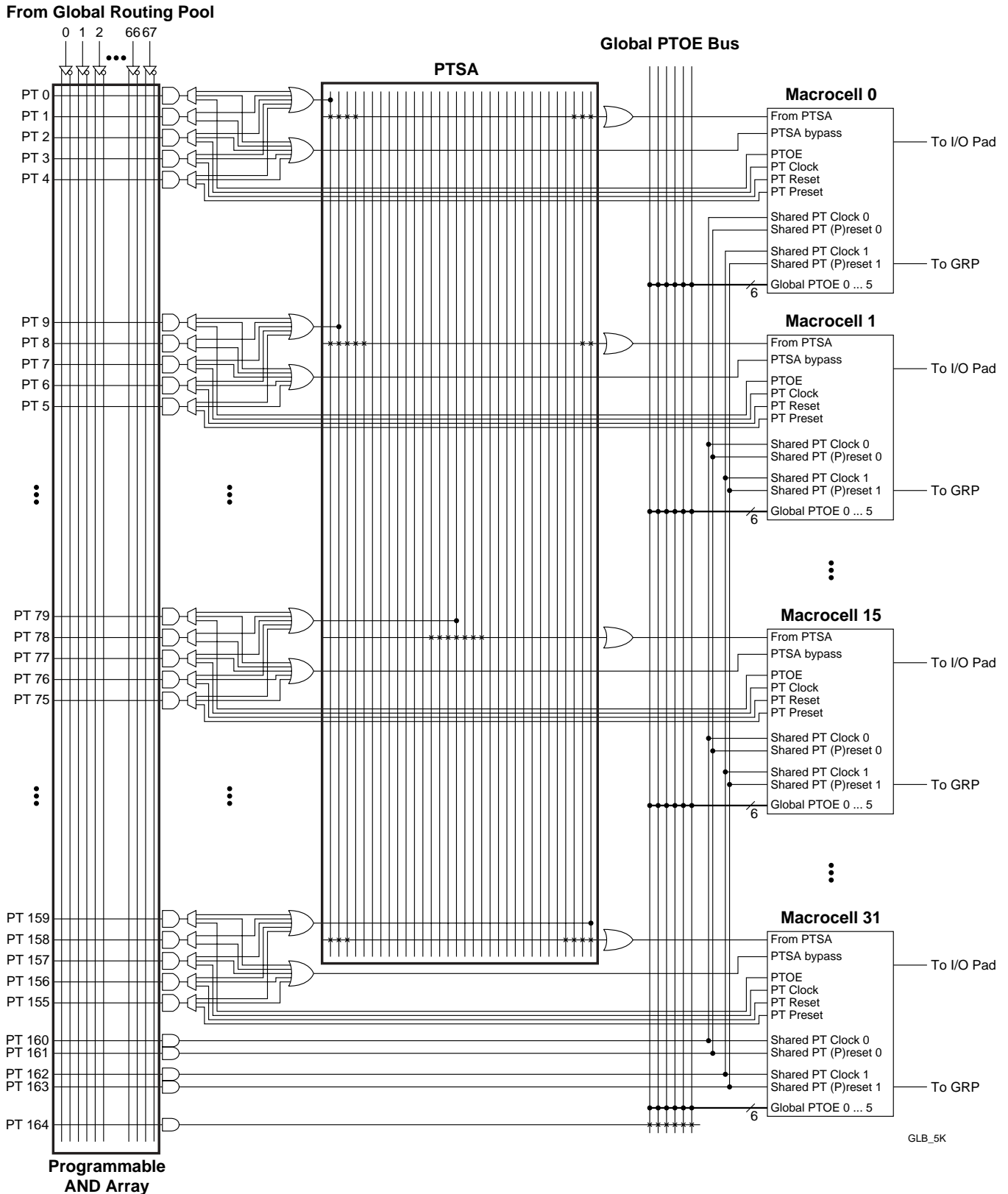
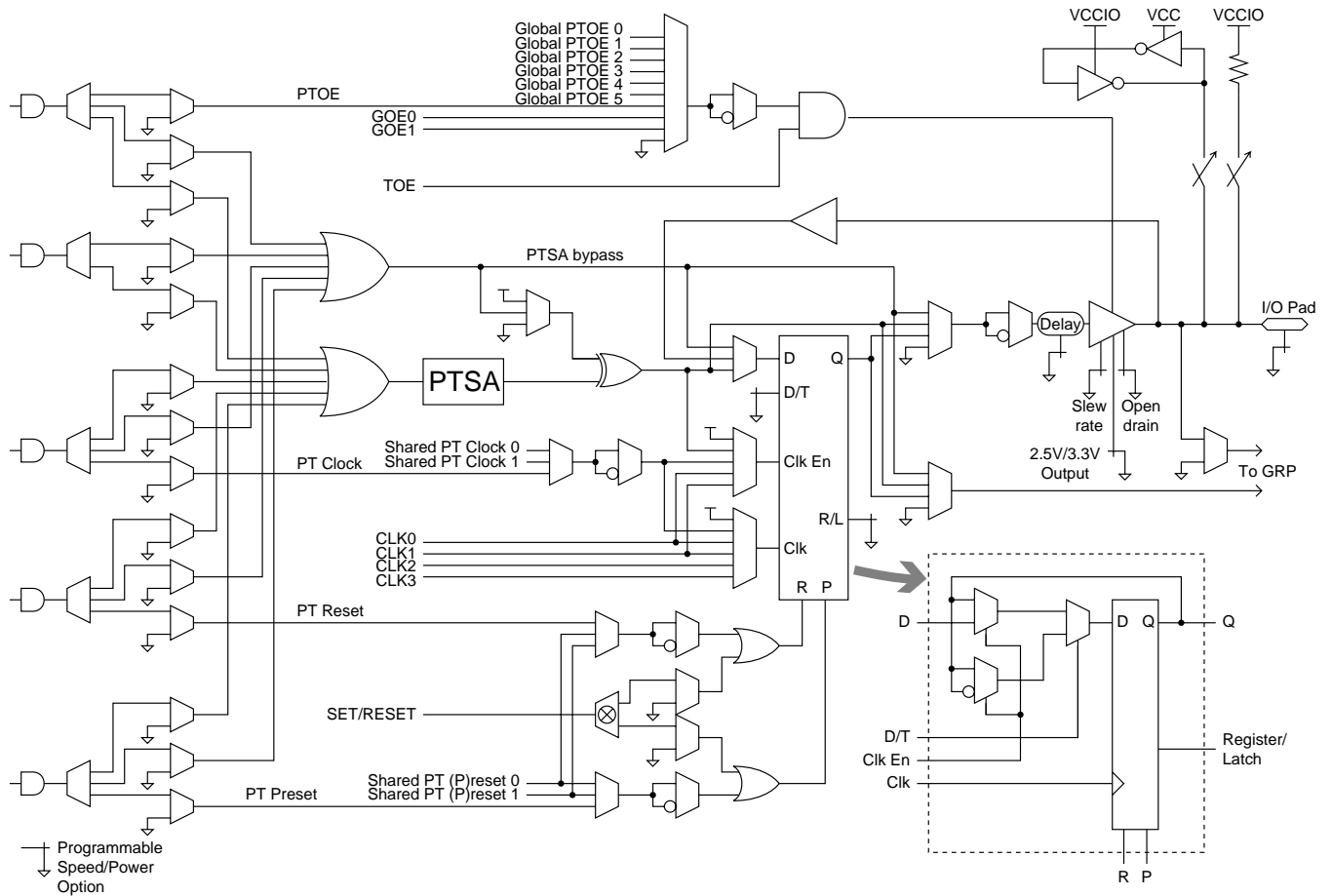

Figure 4. ispLSI 5000V Macrocell



**Global Clock Distribution**

The ispLSI 5000V Family has four dedicated clock input pins: CLK0 - CLK3. CLK0 input is used as the dedicated master clock that has the lowest internal clock skew with no clock inversion to maintain the fastest internal clock

speed. The clock inversion is available on the remaining CLK1 - CLK3 signals. By sharing the pins with the I/O pins, CLK2 and CLK3 can not only be inverted but also is available for logic implementation through GRP signal routing. Figure 5 shows these different clock distribution options.

**Figure 5. ispLSI 5000V Global Clock Structure**

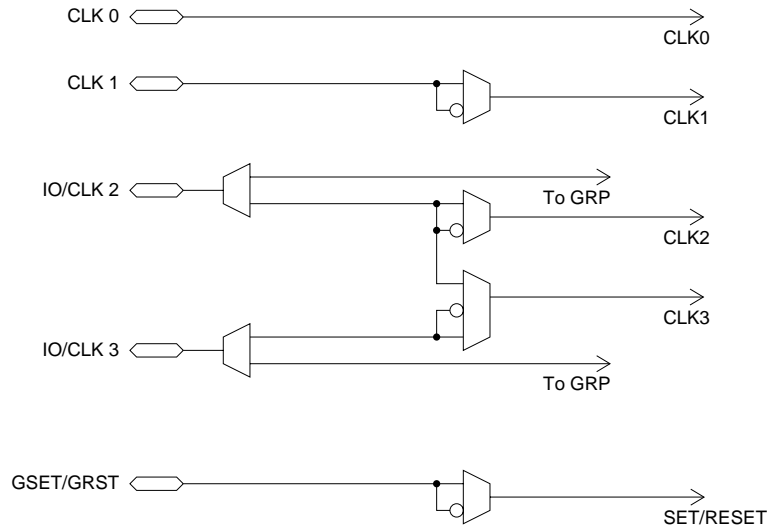

Figure 6. Boundary Scan Register Circuit for I/O Pins

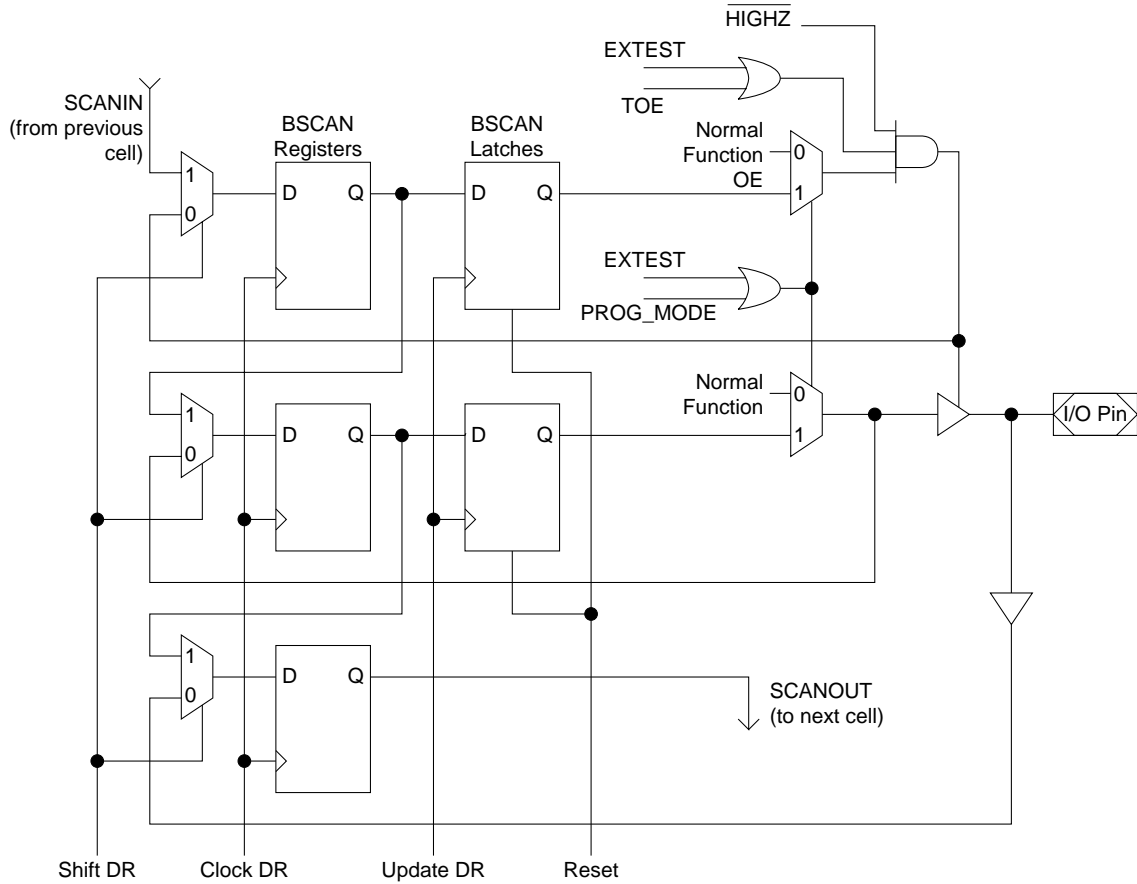

Figure 7. Boundary Scan Register Circuit for Input-Only Pins

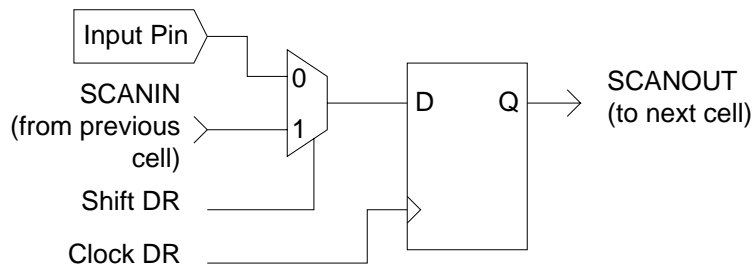
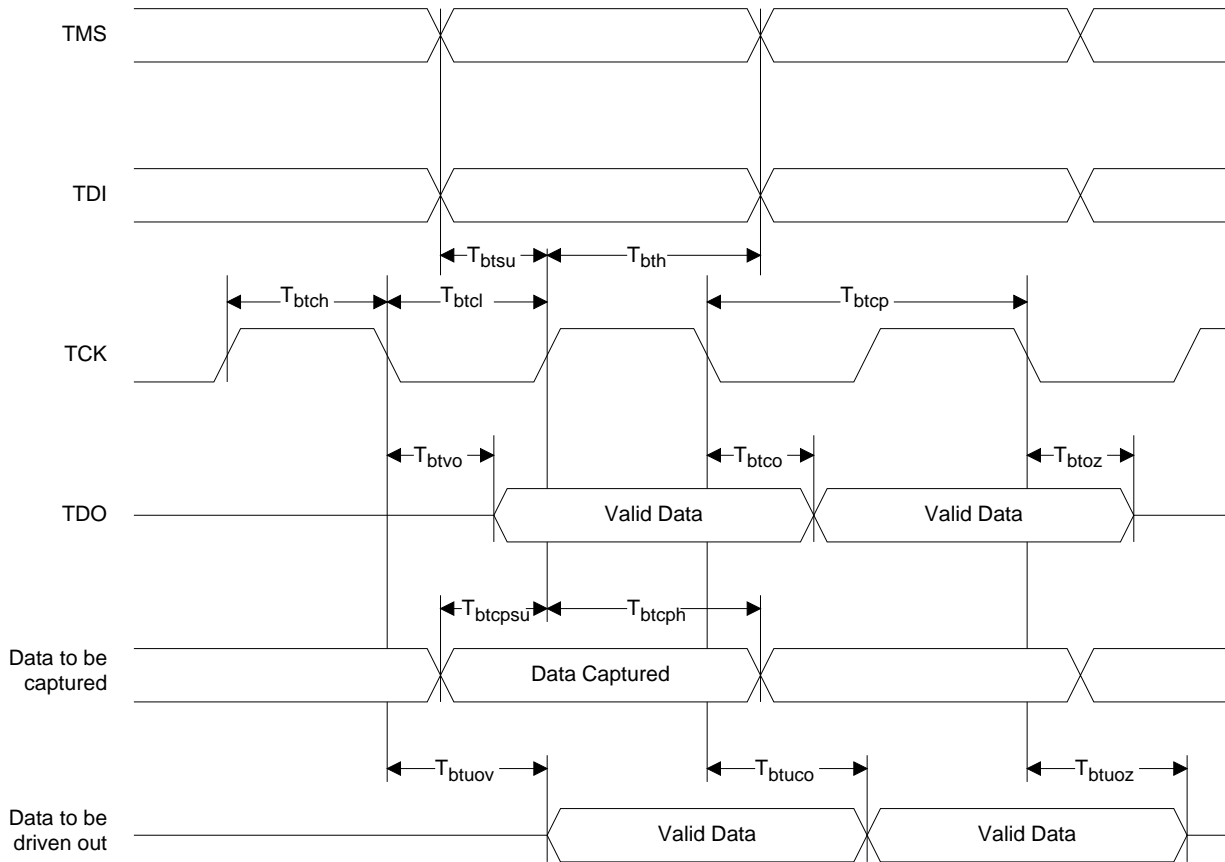

Figure 8. Boundary Scan Waveforms and Timing Specifications



SYMBOL	PARAMETER	MIN	MAX	UNITS
$t_{btcp}$	TCK [BSCAN test] clock pulse width	125	–	ns
$t_{btch}$	TCK [BSCAN test] pulse width high	62.5	–	ns
$t_{btcl}$	TCK [BSCAN test] pulse width low	62.5	–	ns
$t_{btso}$	TCK [BSCAN test] setup time	25	–	ns
$t_{btth}$	TCK [BSCAN test] hold time	25	–	ns
$t_{rf}$	TCK [BSCAN test] rise and fall time	50	–	mV/ns
$t_{btco}$	TAP controller falling edge of clock to valid output	–	25	ns
$t_{btuo}$	TAP controller falling edge of clock to data output disable	–	25	ns
$t_{btvo}$	TAP controller falling edge of clock to data output enable	–	25	ns
$t_{btcpso}$	BSCAN test Capture register setup time	25	–	ns
$t_{btcpsh}$	BSCAN test Capture register hold time	25	–	ns
$t_{btuco}$	BSCAN test Update reg, falling edge of clock to valid output	–	50	ns
$t_{btuoov}$	BSCAN test Update reg, falling edge of clock to output enable	–	50	ns
$t_{btuco}$	BSCAN test Update reg, falling edge of clock to valid output	–	50	ns
$t_{btuoaz}$	BSCAN test Update reg, falling edge of clock to output disable	–	50	ns
$t_{btuoov}$	BSCAN test Update reg, falling edge of clock to output enable	–	50	ns

## Absolute Maximum Ratings 1, 2

Supply Voltage  $V_{CC}$  ..... -0.5 to +5.4V  
 Input Voltage Applied ..... -0.5 to +5.6V  
 Tri-Stated Output Voltage Applied ..... -0.5 to +5.6V  
 Storage Temperature ..... -65 to 150°C  
 Case Temp. with Power Applied ..... -55 to 125°C  
 Max. Junction Temp. ( $T_J$ ) with Power Applied ... 150°C

1. Stresses above those listed under the “Absolute Maximum Ratings” may cause permanent damage to the device. Functional operation of the device at these or at any other conditions above those indicated in the operational sections of this specification is not implied (while programming, follow the programming specifications).
2. Compliance with the Thermal Management section of the Lattice Semiconductor Data Book or CD-ROM is a requirement.

## DC Recommended Operating Condition

SYMBOL	PARAMETER	MIN.	MAX.	UNITS	
$V_{CC}$	Supply Voltage	Commercial $T_A = 0^\circ\text{C}$ to $+70^\circ\text{C}$	3.00	3.60	V
		Industrial $T_A = -40^\circ\text{C}$ to $+85^\circ\text{C}$	3.00	3.60	V
$V_{CCIO}$	I/O Reference Voltage	2.3	3.60	V	

Table 2 - 0005/5000

## Capacitance ( $T_A=25^\circ\text{C}, f=1.0\text{ MHz}$ )

SYMBOL	PARAMETER	TYPICAL	UNITS	TEST CONDITIONS
$C_1$	I/O Capacitance	10	pf	$V_{CC} = 3.3\text{V}, V_{I/O} = 2.0\text{V}$
$C_2$	Clock Capacitance	10	pf	$V_{CC} = 3.3\text{V}, V_{CK} = 2.0\text{V}$
$C_3$	Global Input Capacitance	10	pf	$V_{CC} = 3.3\text{V}, V_G = 2.0\text{V}$

Table 2 - 0006/5384

## Erase Reprogram Specification

PARAMETER	MINIMUM	MAXIMUM	UNITS
ispLSI Erase/Reprogram Cycles	10000	–	Cycles

Table 2-0008/3320

**Switching Test Conditions**

Input Pulse Levels	GND to $V_{CCIO_{min}}$
Input Rise and Fall Time	$\leq 1.5ns$ 10% to 90%
Input Timing Reference Levels	1.5V
Output Timing Reference Levels	1.5V
Output Load	See figure

3-state levels are measured 0.5V from steady-state active level. Table 2 - 0003/5384

**Output Load Conditions (See Figure 8)**

		3.3V		2.5V		
TEST CONDITION		R1	R2	R1	R2	CL
A		316Ω	348Ω	511Ω	475Ω	35pF
B	Active High	∞	348Ω	∞	475Ω	35pF
	Active Low	316Ω	∞	511Ω	∞	35pF
C	Active High to Z at $V_{OH}-0.5V$	∞	348Ω	∞	475Ω	5pF
	Active Low to Z at $V_{OL}+0.5V$	316Ω	∞	511Ω	∞	5pF
D	Slow Slew	∞	∞	∞	∞	35pF

Table 2 - 0004A/5384

**Figure 9. Test Load**

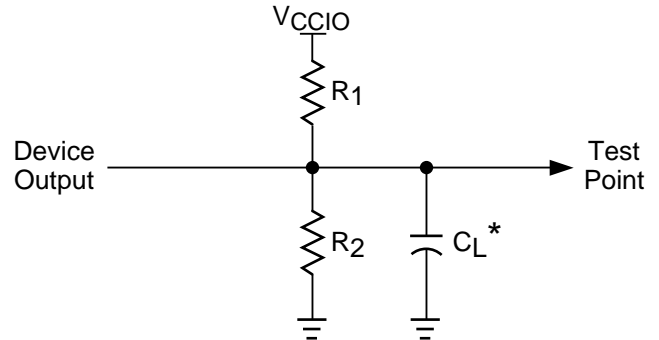

\* $C_L$  includes Test Fixture and Probe Capacitance.

0213D

**DC Electrical Characteristics for 3.3V Range<sup>1</sup>**

**Over Recommended Operating Conditions**

SYMBOL	PARAMETER	CONDITION	MIN.	TYP.	MAX.	UNITS
$V_{CCIO}$	I/O Reference Voltage		3.0	–	3.6	V
$V_{IL}$	Input Low Voltage	$V_{OH} \leq V_{OUT}$ or $V_{OUT} \leq V_{OL(max)}$	-0.3	–	0.8	V
$V_{IH}$	Input High Voltage	$V_{OH} \leq V_{OUT}$ or $V_{OUT} \leq V_{OL(max)}$	2.0	–	5.25	V
$V_{OL}$	Output Low Voltage	$I_{OL} = 8\text{ mA}$	–	–	0.4	V
$V_{OH}$	Output High Voltage	$I_{OH} = -4\text{ mA}$	2.4	–	–	V

Table 2-0007/5512VA

1. I/O voltage configuration must be set to VCC.

## DC Electrical Characteristics for 2.5V Range<sup>1</sup>

### Over Recommended Operating Conditions

SYMBOL	PARAMETER	CONDITION	MIN.	TYP.	MAX.	UNITS
V <sub>CCIO</sub>	I/O Reference Voltage		2.3	–	2.7	V
V <sub>IL</sub>	Input Low Voltage	$V_{OH(min)} \leq V_{OUT}$ or $V_{OUT} \leq V_{OL(max)}$	-0.3	–	0.7	V
V <sub>IH</sub>	Input High Voltage	$V_{OH(min)} \leq V_{OUT}$ or $V_{OUT} \leq V_{OL(max)}$	1.7	–	5.25	V
V <sub>OL</sub>	Output Low Voltage	$V_{CCIO=min}, V_{IN}=V_{IH}$ or $V_{IL}, I_{OL}=100\mu A$	–	–	0.2	V
		$V_{CCIO=min}, V_{IN}=V_{IH}$ or $V_{IL}, I_{OL}=2mA$	–	–	0.7	V
V <sub>OH</sub>	Output High Voltage	$V_{CCIO=min}, V_{IN}=V_{IH}$ or $V_{IL}, I_{OH}= -100\mu A$	2.1	–	–	V
		$V_{CCIO=min}, V_{IN}=V_{IH}$ or $V_{IL}, I_{OH}= -2mA$	1.7	–	–	V

1. I/O voltage configuration must be set to V<sub>CCIO</sub>.

2.5V/5512VA

## DC Electrical Characteristics

### Over Recommended Operating Conditions

SYMBOL	PARAMETER	CONDITION	MIN.	TYP.	MAX.	UNITS
I <sub>IL</sub>	Input or I/O Low Leakage Current	$0V \leq V_{IN} \leq V_{IL(Max)}$	–	–	-10	$\mu A$
I <sub>IH</sub>	Input or I/O High Leakage Current	$(V_{CCIO}-0.2)V \leq V_{IN} \leq V_{CCIO}$	–	–	10	$\mu A$
		$V_{CCIO} \leq V_{IN} \leq 5.25V$	–	–	50	$\mu A$
I <sub>PU</sub> <sup>1</sup>	I/O Active Pullup Current	$0V \leq V_{IN} \leq V_{IL}$	–	–	-150	$\mu A$
I <sub>BHL</sub>	Bus Hold Low Sustaining Current	$V_{IN} = V_{IL(max)}$	40	–	–	$\mu A$
I <sub>BHH</sub>	Bus Hold High Sustaining Current	$V_{IN} = V_{IH(min)}$	-40	–	–	$\mu A$
I <sub>BHLO</sub>	Bus Hold Low Overdrive Current	$0V \leq V_{IN} \leq V_{CCIO}$	–	–	550	$\mu A$
I <sub>BHLH</sub>	Bus Hold High Overdrive Current	$0V \leq V_{IN} \leq V_{CCIO}$	–	–	-550	$\mu A$
I <sub>BHT</sub>	Bus Hold Trip Points		V <sub>IL</sub>	–	V <sub>IH</sub>	V
I <sub>VCCIO</sub>	Current Needed for V <sub>CCIO</sub> Pin	All I/Os Pulled-up, (Total I/Os * I <sub>PUmax</sub> )	–	–	45	mA

1. Pullup is capable of pulling to a minimum voltage of V<sub>OH</sub> under no-load conditions.

DC Char\_5512VA

## External Switching Characteristics

### Over Recommended Operating Conditions

PARAM.	TEST <sup>3</sup> COND.	#	DESCRIPTION <sup>4,5</sup>	-110		-100		-70		UNITS
				MIN.	MAX.	MIN.	MAX.	MIN.	MAX.	
t <sub>pd1</sub> <sup>6</sup>	A	1	Data Prop. Delay, 5PT Bypass	—	8.5	—	10	—	15	ns
t <sub>pd2</sub> <sup>6</sup>	A	2	Data Propagation Delay	—	10	—	13	—	19	ns
f <sub>max</sub>	A	3	Clock Frequency with Internal Feedback <sup>1</sup>	110	—	100	—	70	—	MHz
f <sub>max</sub> (Ext.)	—	4	Clock Freq. with Ext. Feedback, 1/(tsu2 + tco1)	91	—	69	—	45	—	MHz
f <sub>max</sub> (Tog.)	—	5	Clock Frequency, Max Toggle <sup>2</sup>	143	—	125	—	83	—	MHz
t <sub>su1</sub>	—	6	GLB Reg. Setup Time before Clk, 5PT bypass	6	—	8	—	12	—	ns
t <sub>co1</sub> <sup>6</sup>	A	7	GLB Reg. Clock to Output Delay	—	4	—	5.5	—	8	ns
t <sub>h1</sub>	—	8	GLB Reg. Hold Time after Clock, 5PT bypass	0	—	0	—	0	—	ns
t <sub>su2</sub>	—	9	GLB Reg. Setup Time before Clock	7	—	9	—	14	—	ns
t <sub>h2</sub>	—	10	GLB Reg. Hold Time after Clock	0	—	0	—	0	—	ns
t <sub>su3</sub> (CLK0/1)	—	11	GLB Reg. Setup Time before Clock, Input Reg. Path (CLK0/1)	4.5	—	6	—	9	—	ns
t <sub>su3</sub> (CLK2/3)	—	12	GLB Reg. Setup Time before Clock, Input Reg. Path (CLK2/3)	3.5	—	5	—	7	—	ns
t <sub>h3</sub> (CLK0/1)	—	13	GLB Reg. Hold Time after Clock, Input Reg. Path (CLK0/1)	0	—	0	—	0	—	ns
t <sub>h3</sub> (CLK2/3)	—	14	GLB Reg. Hold Time after Clock, Input Reg. Path (CLK2/3)	0	—	0	—	0	—	ns
t <sub>r1</sub>	A	15	Ext. Reset Pin to Output Delay	—	17	—	20	—	30	ns
t <sub>rw1</sub>	—	16	Ext. Reset Pulse Duration	7.5	—	9	—	14	—	ns
t <sub>ptoe/dis</sub>	B/C	17	Local Product Term Output Enable/Disable	—	10	—	12	—	18	ns
t <sub>gptoe/dis</sub>	B/C	18	Global Product Term Output Enable/Disable	—	20	—	24	—	30	ns
t <sub>goe/dis</sub>	B/C	19	Global OE Input to Output Enable/Disable	—	6.5	—	8	—	12	ns
t <sub>wh</sub>	—	20	Ext. Sync. Clock Pulse Duration, High	3.5	—	4	—	6	—	ns
t <sub>wl</sub>	—	21	Ext. Sync. Clock Pulse Duration, Low	3.5	—	4	—	6	—	ns

- Standard 32-bit counter using GRP feedback.
- f<sub>max</sub> (Toggle) may be less than 1/(t<sub>wh</sub> + t<sub>wl</sub>). This is to allow for a clock duty cycle of other than 50%.
- Reference Switching Test Conditions section.
- Unless noted otherwise, all timing numbers are taken with worst case PTSA fanout, a GRP load of 1 GLB, and CLK0.
- Timing parameters measured using normal active output driver.
- The delay parameters are measured with V<sub>cc</sub> as I/O voltage reference. An additional 0.5ns delay is incurred when V<sub>ccio</sub> is used as I/O voltage reference.

Timing Ext.5512VA/4.0.eps

## Internal Timing Parameters<sup>1</sup>

### Over Recommended Operating Conditions

PARAM	# <sup>2</sup>	DESCRIPTION	-110		-100		-70		UNIT
			MIN	MAX	MIN	MAX	MIN	MAX	
<b>I/O Buffer</b>									
tidcom	22	Input Pad and Buffer, Combinatorial Input	–	0.7	–	0.9	–	1.4	ns
tidreg	23	Input Pad and Buffer, Registered Input	–	4.7	–	6.6	–	9.7	ns
todcom	24	Output Pad and Buffer, Combinatorial Output	–	2.4	–	1.7	–	2.6	ns
todreg	25	Output Pad and Buffer, Registered Output	–	1.0	–	2.8	–	4.6	ns
todz	26	Output Buffer Enable/Disable	–	1.7	–	1.7	–	2.6	ns
tslf	27	Slew Rate Adder, Fast Slew	–	0	–	0	–	0	ns
tsls	28	Slew Rate Adder, Slow Slew	–	8.5	–	10	–	15	ns
tslfd	29	Programmable Delay Adder, Fast Slew	–	0.5	–	0.7	–	1	ns
tslsd	30	Programmable Delay Adder, Slow Slew	–	9.5	–	10.7	–	16	ns
<b>GLB/Macrocell Delay Register</b>									
tmbp	31	Macrocell Register/Latch Bypass	–	0	–	0	–	0	ns
tmlat	32	Macrocell Latch Delay	–	1	–	1.4	–	2	ns
tmco	33	Macrocell Register/Latch Clock to Output	–	1.8	–	1	–	1	ns
tmsu	34	Macrocell Register/Latch Setup Time	1	–	1.1	–	1.7	–	ns
tmh	35	Macrocell Register/Latch Hold Time	2.5	–	3.9	–	5.3	–	ns
tmsuce	36	Macrocell Register/Latch CLKEN Setup Time	1	–	1.4	–	2	–	ns
tmhce	37	Macrocell Register/Latch CLKEN Hold Time	1	–	1.4	–	2	–	ns
tmrst	38	Macrocell Register/Latch Set/Reset Time	–	1.8	–	1.4	–	2	ns
tftog	39	Toggle Flip-Flop Feedback	–	1	–	1.3	–	2	ns
<b>AND Array</b>									
tandhs	40	AND Array, High Speed Mode	–	3	–	4	–	6	ns
tandlp	41	AND Array, Low Power Mode	–	5	–	6.6	–	10	ns
<b>PTSA</b>									
t5ptcom	42	5 Product Term Bypass, Combinatorial	–	0.7	–	1.4	–	2	ns
t5ptreg	43	5 Product Term Bypass, Registered	–	1	–	1.7	–	2.3	ns
t5ptxcom	44	5 Product Term XOR, Combinatorial	–	2.5	–	3.6	–	5	ns
t5ptxreg	45	5 Product Term XOR, Registered	–	2.3	–	2.2	–	3.3	ns
tptsacom	46	Product Term Sharing Array, Combinatorial	–	3	–	4.1	–	6	ns
tptsareg	47	Product Term Sharing Array, Registered	–	2	–	2.7	–	4.3	ns
<b>PTSA Controls</b>									
tpck	48	Product Term Clock Delay	–	0.5	–	0.7	–	1	ns
tpcken	49	Product Term CLKEN Delay	–	1	–	1.4	–	2	ns
tscken	50	Shared Product Term CLKEN Delay	–	1	–	1.4	–	2	ns
tsck	51	Shared Product Term Clock Delay	–	0.5	–	0.7	–	1	ns
tptsacken	52	Product Term Sharing Array CLKEN Delay	–	2.0	–	2.4	–	4	ns
tsrst	53	Shared Product Term Set/Reset Delay	–	2.5	–	3.4	–	5	ns
tprst	54	Product Term Set/Reset Delay	–	1.5	–	2	–	3	ns
tpoe	55	Product Term Output Enable/Disable	–	2.9	–	3.4	–	5	ns
tgpoe	56	Global PT Output Enable/Disable	–	13.1	–	15.4	–	17	ns

1. Internal Timing Parameters are not tested and are for reference only. Refer to Timing Model in this data sheet for further details.

**Internal Timing Parameters<sup>1</sup>**

**Over Recommended Operating Conditions**

PARAM	# <sup>2</sup>	DESCRIPTION	-110		-100		-70		UNIT
			MIN	MAX	MIN	MAX	MIN	MAX	
GRP									
tgrpi	57	GRP Delay from I/O Pad	–	1.5	–	2	–	3	ns
tgrpm	58	GRP Delay from Macrocell	–	1.2	–	1.2	–	1.2	ns
Global Control Delays									
tgclk01	59	Global Clock 0 or 1 Delay	–	1.2	–	1.7	–	2.4	ns
tgclk23	60	Global Clock 2 or 3 Delay	–	2.2	–	2.7	–	4.4	ns
tgclken0	61	Global CLKEN 0 Delay	–	1.7	–	2.4	–	3.4	ns
tgclken1	62	Global CLKEN 1 Delay	–	2.7	–	3.4	–	5.4	ns
tgrst	63	Global Set/Reset Delay	–	14.2	–	15.8	–	23.4	ns
tgoe	64	Global OE Delay	–	4.8	–	6.3	–	9.4	ns
ttoe	65	Test OE Delay	–	4.7	–	6.2	–	9.4	ns

1. Internal Timing Parameters are not tested and are for reference only. Refer to Timing Model in this data sheet for further details.

Timing Rev 4.0

**ispLSI 5512VA Timing Model**

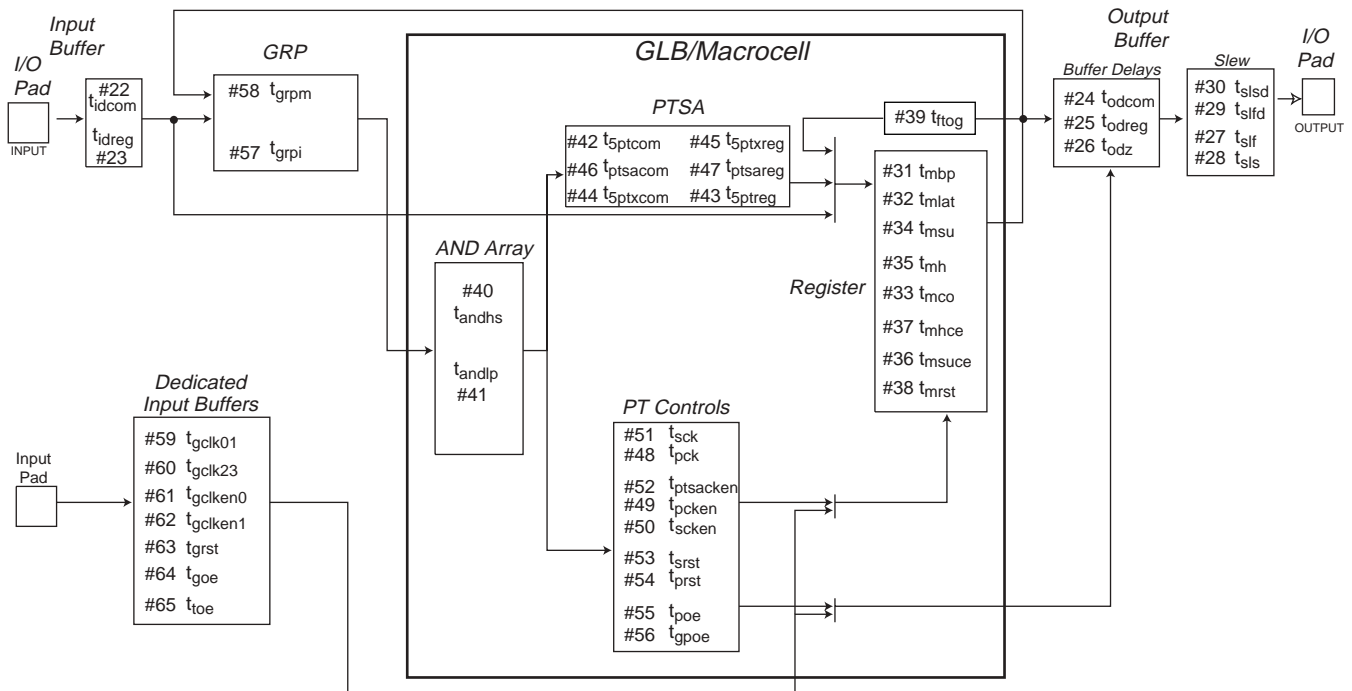

**Power Consumption**

Power consumption in the ispLSI 5512VA device depends on two primary factors: the speed at which the device is operating and the number of product terms used. The product terms have a fuse-selectable speed/power tradeoff setting. Each group of four product terms has a single speed/power tradeoff control fuse that acts on the complete group of four. The fast “high-speed”

setting operates product terms at their normal full power consumption. For portions of the logic that can tolerate longer propagation delays, selecting the slower “low-power” setting will significantly reduce the power dissipation for these product terms. Figure 10 shows the relationship between power and operating speed.

**Figure 10. Typical Device Power Consumption vs fmax**

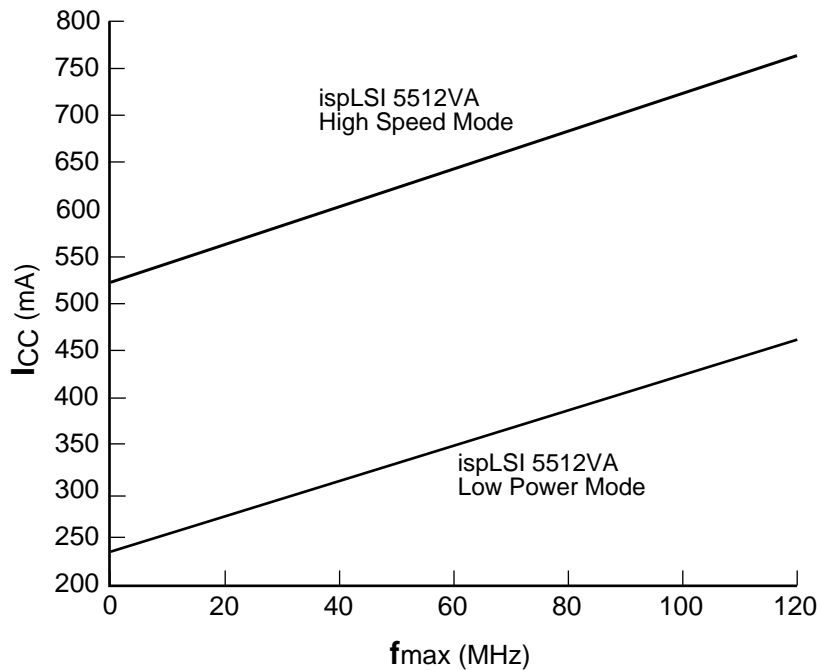

Notes: Configuration of 32 16-bit Counters  
Typical Current at 3.3V, 25° C

ICC can be estimated for the ispLSI 5512VA using the following equation:

**High Speed Mode:**  $ICC = 70 + (\# \text{ of PTs} * 0.4592) + (\# \text{ of nets} * \text{Max. freq} * 0.00391)$

**Low Power Mode:**  $ICC = 70 + (\# \text{ of PTs} * 0.160) + (\# \text{ of nets} * \text{Max. freq} * 0.00391)$

# of PTs = Number of Product Terms used in design

# of nets = Number of Signals used in device

Max. freq = Highest Clock Frequency to the device

The ICC estimate is based on typical conditions (VCC = 3.3V, room temperature) and an assumption of 2 GLB loads on average exists. These values are for estimates only. Since the value of ICC is sensitive to operating conditions and the program in the device, the actual ICC should be verified.

0127/5512va

## Signal Descriptions

Signal Name	Description
TMS	Input - This pin is the Test Mode Select input, which is used to control the JTAG state machine.
TCK	Input - This pin is the Test Clock input pin used to clock through the JTAG state machine.
TDI	Input - This pin is the JTAG Test Data In pin used to load data.
TDO	Output - This pin is the JTAG Test Data Out pin used to shift data out.
TOE / I/O0	Input/Output - This pin functions as either the Test Output Enable pin or an I/O pin based upon customer's design. TOE tristates all I/O pins when a logic low is driven.
GOE0, GOE1	Input - These two pins are the Global Output Enable input pins.
GSET/GRST	Dedicated Set/Reset Input - This pin is available to all registers in the device and can independently be configured as preset, reset or no effect on each register. The global polarity (active high or low input) for this pin is also selectable.
I/O	Input/Output – These are the general purpose I/O used by the logic array.
GND	Ground
NC <sup>1</sup>	No connect.
VCC	Vcc
CLK0, CLK1	Dedicated clock inputs for all registers. Both clocks are muxed before being used as the clock input to all registers in the device.
CLK2 / I/O, CLK3 / I/O	Input/Output - These pins function as either dedicated clock inputs for all registers or an I/O pin based upon customer's design. Both clocks are muxed before being used as the clock input to all registers in the device.
VCCIO	Input - This pin is used if an optional 2.5V output is to be used. Every I/O can independently select either 3.3V or the optional voltage as its output level. If the optional output voltage is not required, this pin must be connected to the Vcc supply. Programmable pull-up resistors and bus-hold latches only draw current from this supply.

1. NC pins are not to be connected to any active signals, VCC or GND.

## 208-Pin PQFP Signal Locations

Signal	Pin
GOE0, GOE1	78, 79
TOE / I/O0	32
GSET/GRST	138
TCK	29
TDI	30
TDO	136
TMS	28
CLK0, CLK1	184,185
CLK2 / I/O89	162
CLK3 / I/O98	173
VCCIO	137
GND	3, 12, 19, 27, 39, 48, 58, 69, 77, 88, 99, 113, 121, 128, 135, 150, 164, 170, 179, 191, 199
VCC	7, 14, 22, 31, 41, 61, 80, 90, 110, 123, 139, 152, 156, 177, 186, 201
NC	49, 50, 51, 52, 101, 102, 103, 104, 105, 106, 107, 108, 109, 157, 158, 207, 208

1. NCs are not to be connected to any active signals, VCC or GND.

## 208-Pin PQFP I/O Locations

I/O #	Pin	I/O #	Pin	I/O #	Pin	I/O #	Pin	I/O #	Pin	I/O #	Pin
0*	32	24	65	48	96	72	140	96	171	120	203
1	33	25	66	49	97	73	141	97	172	121	204
2	34	26	67	50	98	74	142	98*	173	122	205
3	35	27	68	51	100	75	143	99	174	123	206
4	36	28	70	52	111	76	144	100	175	124	1
5	37	29	71	53	112	77	145	101	176	125	2
6	38	30	72	54	114	78	146	102	178	126	4
7	40	31	73	55	115	79	147	103	180	127	5
8	42	32	74	56	116	80	148	104	181	128	6
9	43	33	75	57	117	81	149	105	182	129	8
10	44	34	76	58	118	82	151	106	183	130	9
11	45	35	81	59	119	83	153	107	187	131	10
12	46	36	82	60	120	84	154	108	188	132	11
13	47	37	83	61	122	85	155	109	189	133	13
14	53	38	84	62	124	86	159	110	190	134	15
15	54	39	85	63	125	87	160	111	192	135	16
16	55	40	86	64	126	88	161	112	193	136	17
17	56	41	87	65	127	89*	162	113	194	137	18
18	57	42	89	66	129	90	163	114	195	138	20
19	59	43	91	67	130	91	165	115	196	139	21
20	60	44	92	68	131	92	166	116	197	140	23
21	62	45	93	69	132	93	167	117	198	141	24
22	63	46	94	70	133	94	168	118	200	142	25
23	64	47	95	71	134	95	169	119	202	143	26

\* I/O 89 is multiplexed with CLK2, I/O 98 is multiplexed with CLK3 and I/O 0 is multiplexed with TOE.

**388-Ball BGA Signal Locations**

Signal	Ball
GOE0, GOE1	AF14, AD13
TOE / I/O0	T1
GSET/GRST	L25
TCK	T2
TDI	R3
TDO	N24
TMS	R1
CLK0, CLK1	A13, C14
CLK2 / I/O179	A23
CLK3 / I/O197	B17
VCCIO	M26
GND	A1, A2, A26, B2, B25, B26, C3, C24, D4, D9, D14, D19, D23, H4, J23, L11, L12, L13, L14, L15, L16, M11, M12, M13, M14, M15, M16, N4, N11, N12, N13, N14, N15, N16, P11, P12, P13, P14, P15, P16, P23, R11, R12, R13, R14, R15, R16, T11, T12, T13, T14, T15, T16, V4, W23, AC4, AC8, AC13, AC18, AC23, AD3, AD24, AE1, AE2, AE25, AF1, AF25, AF26
VCC	D6, D11, D16, D21, F4, F23, L4, L23, T4, T23, AA4, AA23, AC6, AC11, AC16, AC21
NC <sup>1</sup>	C9, D2, E24, L1, AC25, AF19

1. NCs are not to be connected to any active signals, VCC or GND.

**388-Ball BGA I/O Locations (Sorted by I/O)**

I/O #	Ball	I/O #	Ball	I/O #	Ball	I/O #	Ball	I/O #	Ball	I/O #	Ball
0*	T1	48	AC9	96	AE23	144	M24	192	D18	240	B4
1	R4	49	AF8	97	AC22	145	L26	193	A19	241	D5
2	U2	50	AD8	98	AF23	146	M23	194	C19	242	A4
3	T3	51	AE9	99	AD22	147	K25	195	B18	243	C5
4	U1	52	AF9	100	AE24	148	L24	196	A18	244	B3
5	U4	53	AE10	101	AD23	149	K26	197*	B17	245	C4
6	V2	54	AD9	102	AF24	150	K23	198	C18	246	A3
7	U3	55	AF10	103	AE26	151	J25	199	A17	247	B1
8	V1	56	AC10	104	AD25	152	K24	200	D17	248	C2
9	W2	57	AE11	105	AD26	153	J26	201	B16	249	C1
10	W1	58	AD10	106	AC24	154	H25	202	C17	250	D3
11	V3	59	AF11	107	AC26	155	H26	203	A16	251	D1
12	Y2	60	AE12	108	AB25	156	J24	204	B15	252	E2
13	W4	61	AF12	109	AB23	157	G25	205	A15	253	E4
14	Y1	62	AD11	110	AB24	158	H23	206	C16	254	E3
15	W3	63	AE13	111	AB26	159	G26	207	B14	255	E1
16	AA2	64	AC12	112	AA25	160	H24	208	D15	256	F2
17	Y4	65	AF13	113	Y23	161	F25	209	A14	257	G4
18	AA1	66	AD12	114	AA24	162	G23	210	C15	258	F3
19	Y3	67	AE14	115	AA26	163	F26	211	B13	259	F1
20	AB2	68	AC14	116	Y25	164	G24	212	D13	260	G2
21	AB1	69	AE15	117	Y26	165	E25	213	B12	261	G1
22	AA3	70	AD14	118	Y24	166	E26	214	C13	262	G3
23	AC2	71	AF15	119	W25	167	F24	215	A12	263	H2
24	AB4	72	AE16	120	V23	168	D25	216	B11	264	J4
25	AC1	73	AD15	121	W26	169	E23	217	C12	265	H1
26	AB3	74	AF16	122	W24	170	D26	218	A11	266	H3
27	AD2	75	AC15	123	V25	171	C25	219	D12	267	J2
28	AC3	76	AE17	124	V26	172	D24	220	B10	268	J1
29	AD1	77	AD16	125	U25	173	C26	221	C11	269	K2
30	AF2	78	AF17	126	V24	174	A25	222	A10	270	J3
31	AE3	79	AC17	127	U26	175	B24	223	D10	271	K1
32	AF3	80	AE18	128	U23	176	A24	224	B9	272	K4
33	AE4	81	AD17	129	T25	177	B23	225	C10	273	L2
34	AD4	82	AF18	130	U24	178	C23	226	A9	274	K3
35	AF4	83	AE19	131	T26	179*	A23	227	B8	275	M2
36	AE5	84	AD18	132	R25	180	B22	228	A8	276	M1
37	AC5	85	AE20	133	R26	181	D22	229	B7	277	L3
38	AD5	86	AC19	134	T24	182	C22	230	D8	278	N2
39	AF5	87	AF20	135	P25	183	A22	231	A7	279	M4
40	AE6	88	AD19	136	R23	184	B21	232	C8	280	N1
41	AC7	89	AE21	137	P26	185	D20	233	B6	281	M3
42	AD6	90	AC20	138	R24	186	C21	234	D7	282	P2
43	AF6	91	AF21	139	N25	187	A21	235	A6	283	P4
44	AE7	92	AD20	140	N23	188	B20	236	C7	284	P1
45	AF7	93	AE22	141	N26	189	A20	237	B5	285	N3
46	AD7	94	AF22	142	P24	190	C20	238	A5	286	R2
47	AE8	95	AD21	143	M25	191	B19	239	C6	287	P3

\* I/O 179 is multiplexed with CLK2, I/O 197 is multiplexed with CLK3 and I/O 0 is multiplexed with TOE.

## 388-Ball BGA I/O Locations (Sorted by Ball)

I/O #	Ball	I/O #	Ball	I/O #	Ball	I/O #	Ball	I/O #	Ball	I/O #	Ball
246	A03	243	C05	261	G01	282	P02	16	AA02	99	AD22
242	A04	239	C06	260	G02	287	P03	22	AA03	101	AD23
238	A05	236	C07	262	G03	283	P04	114	AA24	104	AD25
235	A06	232	C08	257	G04	142	P24	112	AA25	105	AD26
231	A07	225	C10	162	G23	135	P25	115	AA26	31	AE03
228	A08	221	C11	164	G24	137	P26	21	AB01	33	AE04
226	A09	217	C12	157	G25	286	R02	20	AB02	36	AE05
222	A10	214	C13	159	G26	1	R04	26	AB03	40	AE06
218	A11	210	C15	265	H01	136	R23	24	AB04	44	AE07
215	A12	206	C16	263	H02	138	R24	109	AB23	47	AE08
209	A14	202	C17	266	H03	132	R25	110	AB24	51	AE09
205	A15	198	C18	158	H23	133	R26	108	AB25	53	AE10
203	A16	194	C19	160	H24	0*	T01	111	AB26	57	AE11
199	A17	190	C20	154	H25	3	T03	25	AC01	60	AE12
196	A18	186	C21	155	H26	134	T24	23	AC02	63	AE13
193	A19	182	C22	268	J01	129	T25	28	AC03	67	AE14
189	A20	178	C23	267	J02	131	T26	37	AC05	69	AE15
187	A21	171	C25	270	J03	4	U01	41	AC07	72	AE16
183	A22	173	C26	264	J04	2	U02	48	AC09	76	AE17
179*	A23	251	D01	156	J24	7	U03	56	AC10	80	AE18
176	A24	250	D03	151	J25	5	U04	64	AC12	83	AE19
174	A25	241	D05	153	J26	128	U23	68	AC14	85	AE20
247	B01	234	D07	271	K01	130	U24	75	AC15	89	AE21
244	B03	230	D08	269	K02	125	U25	79	AC17	93	AE22
240	B04	223	D10	274	K03	127	U26	86	AC19	96	AE23
237	B05	219	D12	272	K04	8	V01	90	AC20	100	AE24
233	B06	212	D13	150	K23	6	V02	97	AC22	103	AE26
229	B07	208	D15	152	K24	11	V03	106	AC24	30	AF02
227	B08	200	D17	147	K25	120	V23	107	AC26	32	AF03
224	B09	192	D18	149	K26	126	V24	29	AD01	35	AF04
220	B10	185	D20	273	L02	123	V25	27	AD02	39	AF05
216	B11	181	D22	277	L03	124	V26	34	AD04	43	AF06
213	B12	172	D24	148	L24	10	W01	38	AD05	45	AF07
211	B13	168	D25	145	L26	9	W02	42	AD06	49	AF08
207	B14	170	D26	276	M01	15	W03	46	AD07	52	AF09
204	B15	255	E01	275	M02	13	W04	50	AD08	55	AF10
201	B16	252	E02	281	M03	122	W24	54	AD09	59	AF11
197*	B17	254	E03	279	M04	119	W25	58	AD10	61	AF12
195	B18	253	E04	146	M23	121	W26	62	AD11	65	AF13
191	B19	169	E23	144	M24	14	Y01	66	AD12	71	AF15
188	B20	165	E25	143	M25	12	Y02	70	AD14	74	AF16
184	B21	166	E26	280	N01	19	Y03	73	AD15	78	AF17
180	B22	259	F01	278	N02	17	Y04	77	AD16	82	AF18
177	B23	256	F02	285	N03	113	Y23	81	AD17	87	AF20
175	B24	258	F03	140	N23	118	Y24	84	AD18	91	AF21
249	C01	167	F24	139	N25	116	Y25	88	AD19	94	AF22
248	C02	161	F25	141	N26	117	Y26	92	AD20	98	AF23
245	C04	163	F26	284	P01	18	AA01	95	AD21	102	AF24

\* I/O 179 is multiplexed with CLK2, I/O 197 is multiplexed with CLK3 and I/O 0 is multiplexed with TOE.

**Signal Locations (272-Ball BGA)**

Signal	Ball
GOE0, GOE1	V11, U11
TOE / I/O 0	M2
GSET/GRST	J18
TCK	L4
TDI	M1
TDO	J20
TMS	L3
CLK0, CLK1	C10, D10
CLK2 / I/O 119	A18
CLK3 / I/O 131	B13
VCCIO	J19
GND	A1, D4, D8, D13, D17, H4, H17, J9, J10, J11, J12, K9, K10, K11, K12, L9, L10, L11, L12, M9, M10, M11, M12, N4, N17, U4, U8, U13, U17
VCC	D6, D11, D15, F4, F17, K4, L17, R4, R17, U6, U10, U15
NC <sup>1</sup>	A17, B3, B18, B19, B20, C3, C5, C18, C19, D3, D19, E2, P19, R3, T4, T17, T20, U1, U2, U3, W1, W2, W4, W17, W19, W20, Y2, Y12, Y20

1. NCs are not to be connected to any active signals, VCC or GND.

## 272-Ball BGA I/O Locations (Sorted by I/O)

I/O #	Ball	I/O #	Ball	I/O #	Ball	I/O #	Ball	I/O #	Ball	I/O #	Ball
0*	M2	32	W7	64	U16	96	J17	128	B14	160	A3
1	M3	33	Y7	65	V17	97	H20	129	A14	161	D5
2	M4	34	V8	66	W18	98	H19	130	C13	162	C4
3	N1	35	W8	67	Y19	99	H18	131*	B13	163	B2
4	N2	36	Y8	68	V18	100	G20	132	A13	164	A2
5	N3	37	U9	69	V19	101	G19	133	D12	165	B1
6	P1	38	V9	70	U19	102	F20	134	C12	166	C2
7	P2	39	W9	71	U18	103	G18	135	B12	167	D2
8	R1	40	Y9	72	V20	104	F19	136	A12	168	E4
9	P3	41	W10	73	U20	105	E20	137	B11	169	C1
10	R2	42	V10	74	T18	106	G17	138	C11	170	D1
11	T1	43	Y10	75	T19	107	F18	139	A11	171	E3
12	P4	44	Y11	76	R18	108	E19	140	A10	172	E1
13	T2	45	W11	77	P17	109	D20	141	B10	173	F3
14	T3	46	W12	78	R19	110	E18	142	A9	174	G4
15	V1	47	V12	79	R20	111	C20	143	B9	175	F2
16	V2	48	U12	80	P18	112	E17	144	C9	176	F1
17	V3	49	Y13	81	P20	113	D18	145	D9	177	G3
18	Y1	50	W13	82	N18	114	A20	146	A8	178	G2
19	W3	51	V13	83	N19	115	A19	147	B8	179	G1
20	V4	52	Y14	84	N20	116	B17	148	C8	180	H3
21	U5	53	W14	85	M17	117	C17	149	A7	181	H2
22	Y3	54	Y15	86	M18	118	D16	150	B7	182	H1
23	Y4	55	V14	87	M19	119*	A18	151	A6	183	J4
24	V5	56	W15	88	M20	120	C16	152	C7	184	J3
25	W5	57	Y16	89	L19	121	B16	153	B6	185	J2
26	Y5	58	U14	90	L18	122	A16	154	A5	186	J1
27	V6	59	V15	91	L20	123	C15	155	D7	187	K2
28	U7	60	W16	92	K20	124	D14	156	C6	188	K3
29	W6	61	Y17	93	K19	125	B15	157	B5	189	K1
30	Y6	62	V16	94	K18	126	A15	158	A4	190	L1
31	V7	63	Y18	95	K17	127	C14	159	B4	191	L2

\* I/O 119 is multiplexed with CLK2, I/O 131 is multiplexed with CLK3 and I/O 0 is multiplexed with TOE.

**272-Ball BGA I/O Locations (Sorted by Ball)**

I/O #	Ball	I/O #	Ball	I/O #	Ball	I/O #	Ball	I/O #	Ball	I/O #	Ball
164	A2	121	B16	108	E19	93	K19	11	T1	72	V20
160	A3	116	B17	105	E20	92	K20	13	T2	19	W3
158	A4	169	C1	176	F1	190	L1	14	T3	25	W5
154	A5	166	C2	175	F2	191	L2	74	T18	29	W6
151	A6	162	C4	173	F3	90	L18	75	T19	32	W7
149	A7	156	C6	107	F18	89	L19	21	U5	35	W8
146	A8	152	C7	104	F19	91	L20	28	U7	39	W9
142	A9	148	C8	102	F20	0*	M2	37	U9	41	W10
140	A10	144	C9	179	G1	1	M3	48	U12	45	W11
139	A11	138	C11	178	G2	2	M4	58	U14	46	W12
136	A12	134	C12	177	G3	85	M17	64	U16	50	W13
132	A13	130	C13	174	G4	86	M18	71	U18	53	W14
129	A14	127	C14	106	G17	87	M19	70	U19	56	W15
126	A15	123	C15	103	G18	88	M20	73	U20	60	W16
122	A16	120	C16	101	G19	3	N1	15	V1	66	W18
119*	A18	117	C17	100	G20	4	N2	16	V2	18	Y1
115	A19	111	C20	182	H1	5	N3	17	V3	22	Y3
114	A20	170	D1	181	H2	82	N18	20	V4	23	Y4
165	B1	167	D2	180	H3	83	N19	24	V5	26	Y5
163	B2	161	D5	99	H18	84	N20	27	V6	30	Y6
159	B4	155	D7	98	H19	6	P1	31	V7	33	Y7
157	B5	145	D9	97	H20	7	P2	34	V8	36	Y8
153	B6	133	D12	186	J1	9	P3	38	V9	40	Y9
150	B7	124	D14	185	J2	12	P4	42	V10	43	Y10
147	B8	118	D16	184	J3	77	P17	47	V12	44	Y11
143	B9	113	D18	183	J4	80	P18	51	V13	49	Y13
141	B10	109	D20	96	J17	81	P20	55	V14	52	Y14
137	B11	172	E1	189	K1	8	R1	59	V15	54	Y15
135	B12	171	E3	187	K2	10	R2	62	V16	57	Y16
131*	B13	168	E4	188	K3	76	R18	65	V17	61	Y17
128	B14	112	E17	95	K17	78	R19	68	V18	63	Y18
125	B15	110	E18	94	K18	79	R20	69	V19	67	Y19

\* I/O 119 is multiplexed with CLK2, I/O 131 is multiplexed with CLK3 and I/O 0 is multiplexed with TOE.

**Signal Configuration**

**ispLSI 5512VA 272-ball BGA**

	20	19	18	17	16	15	14	13	12	11	10	9	8	7	6	5	4	3	2	1																	
A	I/O 114	I/O 115	CLK2/ I/O 119	NC <sup>1</sup>	I/O 122	I/O 126	I/O 129	I/O 132	I/O 136	I/O 139	I/O 140	I/O 142	I/O 146	I/O 149	I/O 151	I/O 154	I/O 158	I/O 160	I/O 164	GND	A																
B	NC <sup>1</sup>	NC <sup>1</sup>	NC <sup>1</sup>	I/O 116	I/O 121	I/O 125	I/O 128	CLK3/ I/O 131	I/O 135	I/O 137	I/O 141	I/O 143	I/O 147	I/O 150	I/O 153	I/O 157	I/O 159	NC <sup>1</sup>	I/O 163	I/O 165	B																
C	I/O 111	NC <sup>1</sup>	NC <sup>1</sup>	I/O 117	I/O 120	I/O 123	I/O 127	I/O 130	I/O 134	I/O 138	CLK0	I/O 144	I/O 148	I/O 152	I/O 156	NC <sup>1</sup>	I/O 162	NC <sup>1</sup>	I/O 166	I/O 169	C																
D	I/O 109	NC <sup>1</sup>	I/O 113	GND	I/O 118	VCC	I/O 124	GND	I/O 133	VCC	CLK1	I/O 145	GND	I/O 155	VCC	I/O 161	GND	NC <sup>1</sup>	I/O 167	I/O 170	D																
E	I/O 105	I/O 108	I/O 110	I/O 112	<b>ispLSI 5512VA</b> Bottom View <table border="1" style="margin: 10px auto;"> <tr><td>GND</td><td>GND</td><td>GND</td><td>GND</td></tr> <tr><td>GND</td><td>GND</td><td>GND</td><td>GND</td></tr> <tr><td>GND</td><td>GND</td><td>GND</td><td>GND</td></tr> <tr><td>GND</td><td>GND</td><td>GND</td><td>GND</td></tr> </table>												GND	GND	GND	GND	GND	GND	GND	GND	GND	GND	GND	GND	GND	GND	GND	GND	I/O 168	I/O 171	NC <sup>1</sup>	I/O 172	E
GND	GND	GND	GND																																		
GND	GND	GND	GND																																		
GND	GND	GND	GND																																		
GND	GND	GND	GND																																		
F	I/O 102	I/O 104	I/O 107	VCC													VCC	I/O 173	I/O 175	I/O 176	F																
G	I/O 100	I/O 101	I/O 103	I/O 106													I/O 174	I/O 177	I/O 178	I/O 179	G																
H	I/O 97	I/O 98	I/O 99	GND													GND	I/O 180	I/O 181	I/O 182	H																
J	TDO	VCCIO	SET/ RST	I/O 96													I/O 183	I/O 184	I/O 185	I/O 186	J																
K	I/O 92	I/O 93	I/O 94	I/O 95													VCC	I/O 188	I/O 187	I/O 189	K																
L	I/O 91	I/O 89	I/O 90	VCC	TCK	TMS	I/O 191	I/O 190	L																												
M	I/O 88	I/O 87	I/O 86	I/O 85	I/O 2	I/O 1	TOE I/O 0	TDI	M																												
N	I/O 84	I/O 83	I/O 82	GND	GND	I/O 5	I/O 4	I/O 3	N																												
P	I/O 81	NC <sup>1</sup>	I/O 80	I/O 77	I/O 12	I/O 9	I/O 7	I/O 6	P																												
R	I/O 79	I/O 78	I/O 76	VCC	VCC	NC <sup>1</sup>	I/O 10	I/O 8	R																												
T	NC <sup>1</sup>	I/O 75	I/O 74	NC <sup>1</sup>	NC <sup>1</sup>	I/O 14	I/O 13	I/O 11	T																												
U	I/O 73	I/O 70	I/O 71	GND	I/O 64	VCC	I/O 58	GND	I/O 48	GOE1	VCC	I/O 37	GND	I/O 28	VCC	I/O 21	GND	NC <sup>1</sup>	NC <sup>1</sup>	NC <sup>1</sup>	U																
V	I/O 72	I/O 69	I/O 68	I/O 65	I/O 62	I/O 59	I/O 55	I/O 51	I/O 47	GOE0	I/O 42	I/O 38	I/O 34	I/O 31	I/O 27	I/O 24	I/O 20	I/O 17	I/O 16	I/O 15	V																
W	NC <sup>1</sup>	NC <sup>1</sup>	I/O 66	NC <sup>1</sup>	I/O 60	I/O 56	I/O 53	I/O 50	I/O 46	I/O 45	I/O 41	I/O 39	I/O 35	I/O 32	I/O 29	I/O 25	NC <sup>1</sup>	I/O 19	NC <sup>1</sup>	NC <sup>1</sup>	W																
Y	NC <sup>1</sup>	I/O 67	I/O 63	I/O 61	I/O 57	I/O 54	I/O 52	I/O 49	NC <sup>1</sup>	I/O 44	I/O 43	I/O 40	I/O 36	I/O 33	I/O 30	I/O 26	I/O 23	I/O 22	NC <sup>1</sup>	I/O 18	Y																

1. NCs are not to be connected to any active signals, Vcc or GND.

272 BGA/5512VA

Note: Ball A1 indicator dot on top side of package.

**Signal Configuration**

**ispLSI 5512VA 388-ball BGA**

	26	25	24	23	22	21	20	19	18	17	16	15	14	13	12	11	10	9	8	7	6	5	4	3	2	1	
<b>A</b>	GND	I/O 174	I/O 176	I/O 179/CLK2	I/O 183	I/O 187	I/O 189	I/O 193	I/O 196	I/O 199	I/O 203	I/O 205	I/O 209	CLK0	I/O 215	I/O 218	I/O 222	I/O 226	I/O 228	I/O 231	I/O 235	I/O 238	I/O 242	I/O 246	GND	GND	<b>A</b>
<b>B</b>	GND	GND	I/O 175	I/O 177	I/O 180	I/O 184	I/O 188	I/O 191	I/O 195	I/O 197/CLK3	I/O 201	I/O 204	I/O 207	I/O 211	I/O 213	I/O 216	I/O 220	I/O 224	I/O 227	I/O 229	I/O 233	I/O 237	I/O 240	I/O 244	GND	I/O 247	<b>B</b>
<b>C</b>	I/O 173	I/O 171	GND	I/O 178	I/O 182	I/O 186	I/O 190	I/O 194	I/O 198	I/O 202	I/O 206	I/O 210	CLK1	I/O 214	I/O 217	I/O 221	I/O 225	NC <sup>1</sup>	I/O 232	I/O 236	I/O 239	I/O 243	I/O 245	GND	I/O 248	I/O 249	<b>C</b>
<b>D</b>	I/O 170	I/O 168	I/O 172	GND	I/O 181	VCC	I/O 185	GND	I/O 192	I/O 200	VCC	I/O 208	GND	I/O 212	I/O 219	VCC	I/O 223	GND	I/O 230	I/O 234	VCC	I/O 241	GND	I/O 250	NC <sup>1</sup>	I/O 251	<b>D</b>
<b>E</b>	I/O 166	I/O 165	NC <sup>1</sup>	I/O 169																			I/O 253	I/O 254	I/O 252	I/O 255	<b>E</b>
<b>F</b>	I/O 163	I/O 161	I/O 167	VCC																			VCC	I/O 258	I/O 256	I/O 259	<b>F</b>
<b>G</b>	I/O 159	I/O 157	I/O 164	I/O 162																			I/O 257	I/O 262	I/O 260	I/O 261	<b>G</b>
<b>H</b>	I/O 155	I/O 154	I/O 160	I/O 158																			GND	I/O 266	I/O 263	I/O 265	<b>H</b>
<b>J</b>	I/O 153	I/O 151	I/O 156	GND																			I/O 264	I/O 270	I/O 267	I/O 268	<b>J</b>
<b>K</b>	I/O 149	I/O 147	I/O 152	I/O 150																			I/O 272	I/O 274	I/O 269	I/O 271	<b>K</b>
<b>L</b>	I/O 145	SET/RST	I/O 148	VCC	GND												VCC						I/O 277	I/O 273	NC <sup>1</sup>	<b>L</b>	
<b>M</b>	VCCIO	I/O 143	I/O 144	I/O 146	GND												I/O						I/O 279	I/O 281	I/O 275	I/O 276	<b>M</b>
<b>N</b>	I/O 141	I/O 139	TDO	I/O 140	GND												GND						I/O 285	I/O 278	I/O 280	<b>N</b>	
<b>P</b>	I/O 137	I/O 135	I/O 142	GND	GND												I/O						I/O 283	I/O 287	I/O 282	I/O 284	<b>P</b>
<b>R</b>	I/O 133	I/O 132	I/O 138	I/O 136	GND												I/O						I/O 1	TDI	I/O 286	TMS	<b>R</b>
<b>T</b>	I/O 131	I/O 129	I/O 134	VCC	GND												VCC						I/O 3	TCK	I/O 0/TOE	<b>T</b>	
<b>U</b>	I/O 127	I/O 125	I/O 130	I/O 128	GND												I/O						I/O 5	I/O 7	I/O 2	I/O 4	<b>U</b>
<b>V</b>	I/O 124	I/O 123	I/O 126	I/O 120	GND												GND						I/O 11	I/O 6	I/O 8	<b>V</b>	
<b>W</b>	I/O 121	I/O 119	I/O 122	GND	I/O												I/O						I/O 13	I/O 15	I/O 9	I/O 10	<b>W</b>
<b>Y</b>	I/O 117	I/O 116	I/O 118	I/O 113	I/O												I/O						I/O 17	I/O 19	I/O 12	I/O 14	<b>Y</b>
<b>AA</b>	I/O 115	I/O 112	I/O 114	VCC	VCC												VCC						I/O 22	I/O 16	I/O 18	<b>AA</b>	
<b>AB</b>	I/O 111	I/O 108	I/O 110	I/O 109	I/O												I/O						I/O 24	I/O 26	I/O 20	I/O 21	<b>AB</b>
<b>AC</b>	I/O 107	NC <sup>1</sup>	I/O 106	GND	I/O 97	VCC	I/O 90	I/O 86	GND	I/O 79	VCC	I/O 75	I/O 68	GND	I/O 64	VCC	I/O 56	I/O 48	GND	I/O 41	VCC	I/O 37	GND	I/O 28	I/O 23	I/O 25	<b>AC</b>
<b>AD</b>	I/O 105	I/O 104	GND	I/O 101	I/O 99	I/O 95	I/O 92	I/O 88	I/O 84	I/O 81	I/O 77	I/O 73	I/O 70	GOE1	I/O 66	I/O 62	I/O 58	I/O 54	I/O 50	I/O 46	I/O 42	I/O 38	I/O 34	GND	I/O 27	I/O 29	<b>AD</b>
<b>AE</b>	I/O 103	GND	I/O 100	I/O 96	I/O 93	I/O 89	I/O 85	I/O 83	I/O 80	I/O 76	I/O 72	I/O 69	I/O 67	I/O 63	I/O 60	I/O 57	I/O 53	I/O 51	I/O 47	I/O 44	I/O 40	I/O 36	I/O 33	I/O 31	GND	GND	<b>AE</b>
<b>AF</b>	GND	GND	I/O 102	I/O 98	I/O 94	I/O 91	NC <sup>1</sup>	I/O 87	I/O 82	I/O 78	I/O 74	I/O 71	GOE0	I/O 65	I/O 61	I/O 59	I/O 55	I/O 52	I/O 49	I/O 45	I/O 43	I/O 39	I/O 35	I/O 32	I/O 30	GND	<b>AF</b>

**ispLSI 5512VA**  
Bottom View

1. NC pins are not to be connected to any active signals, VCC or GND.  
Note: Ball A1 indicator dot on top side of package.

**Pin Configuration**

**ispLSI 5512VA 208-pin PQFP (with Heat Spreader)**

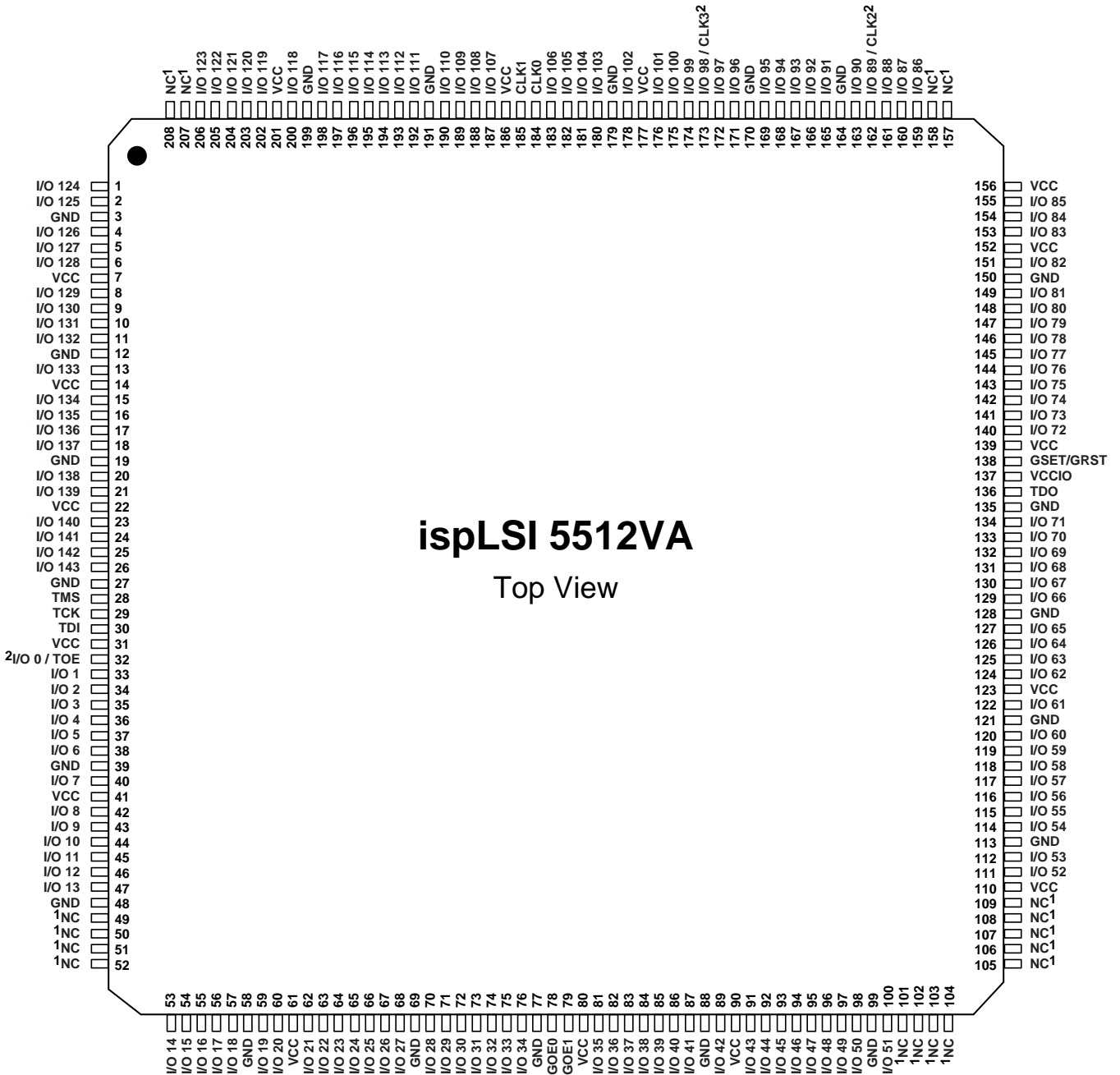

208-PQFP/5512VA

1. NC pins are not to be connected to any active signal, Vcc or GND.
2. Pins have dual function capability.

## Part Number Description

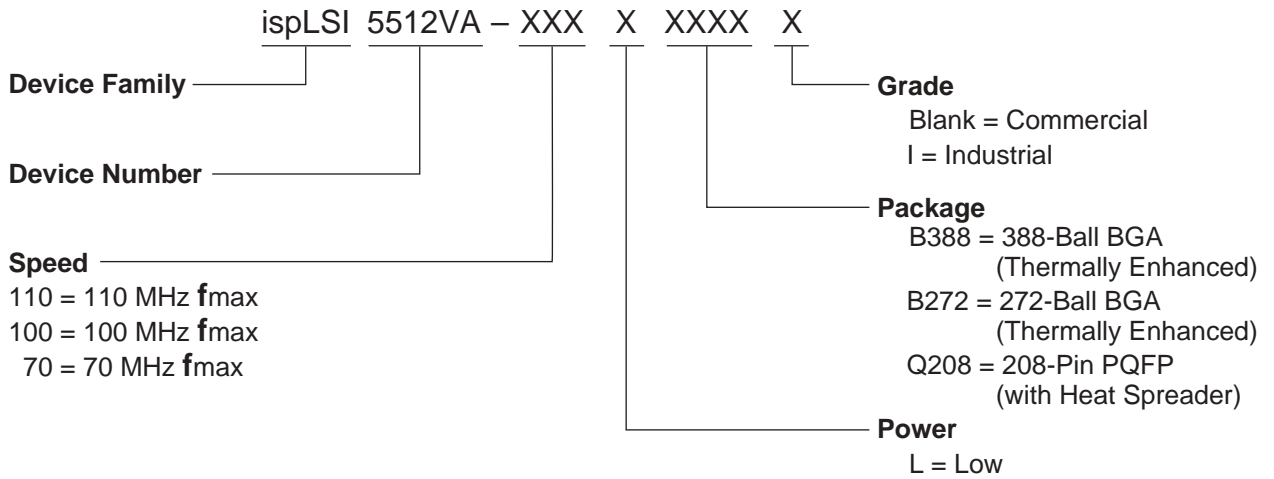

0212/5512va

## Ordering Information

### COMMERCIAL

Family	$f_{max}$	tpd	Ordering Number	Package
ispLSI	110	8.5	ispLSI5512VA-110LB272	272-Ball BGA
	110	8.5	ispLSI 5512VA-110LB388	388-Ball BGA
	110	8.5	ispLSI 5512VA-110LQ208	208-Pin PQFP
	100	10	ispLSI 5512VA-100LB272	272-Ball BGA
	100	10	ispLSI 5512VA-100LB388	388-Ball BGA
	100	10	ispLSI 5512VA-100LQ208	208-Pin PQFP
	70	15	ispLSI 5512VA-70LB272	272-Ball BGA
	70	15	ispLSI 5512VA-70LB388	388-Ball BGA
	70	15	ispLSI 5512VA-70LQ208	208-Pin PQFP

### INDUSTRIAL

Family	$f_{max}$	tpd	Ordering Number	Package
ispLSI	70	15	ispLSI 5512VA-70LB388I	388-Ball BGA

## Looking for pricing, stock, or lifecycle information?

Click below to explore more details on WIN SOURCE:

- [⊖ View ISPLSI 5512VA-110LB272 on WIN SOURCE](#)
- [⊖ Lattice Semiconductor Corporation Information](#)

## Optimize Your Supply Chain with WIN SOURCE Solutions

- ✓ Global Sourcing Solution
- ✓ Obsolete Management
- ✓ Cost Control Management
- ✓ Shortage Management
- ✓ Alternative Solution
- ✓ Excess Inventory Management