



NOT RECOMMENDED FOR NEW DESIGNS  
RECOMMENDED REPLACEMENT PART  
ISL97519A

ISL97516

600kHz/1.2MHz PWM Step-Up Regulator

FN9261  
Rev 6.00  
March 28, 2014

The ISL97516 is a high frequency, high efficiency step-up voltage regulator operated at constant frequency PWM mode. With a 2.0A typical switch current limit and 200mΩ MOSFET, it can deliver over 90% efficiency. The selectable 600kHz and 1.2MHz allows smaller inductors and faster transient response. An external compensation pin gives the user greater flexibility in setting frequency compensation allowing for the use of low ESR Ceramic output capacitors.

When shut down, it draws <1μA of current and can operate down to 2.3V input supply. These features along with 1.2MHz switching frequency make it an ideal device for portable equipment and TFT-LCD displays.

The ISL97516 is available in an 8 Ld MSOP package with a maximum height of 1.1mm. The device is specified for operation over the full -40°C to +85°C temperature range.

### Features

- >90% Efficiency
- 2.0A, 200mΩ Power MOSFET
- 2.3V to 5.5V Input
- 1.1\*VIN to 25V Output
- 600kHz/1.2MHz Switching Frequency Selection
- Adjustable Soft-Start
- Internal Thermal Protection
- 1.1mm Max Height 8 Ld MSOP Package
- Pb-free (RoHS compliant)

### Applications

- TFT-LCD displays
- DSL modems
- PCMCIA cards
- Digital cameras
- GSM/CDMA phones
- Portable equipment
- Handheld devices

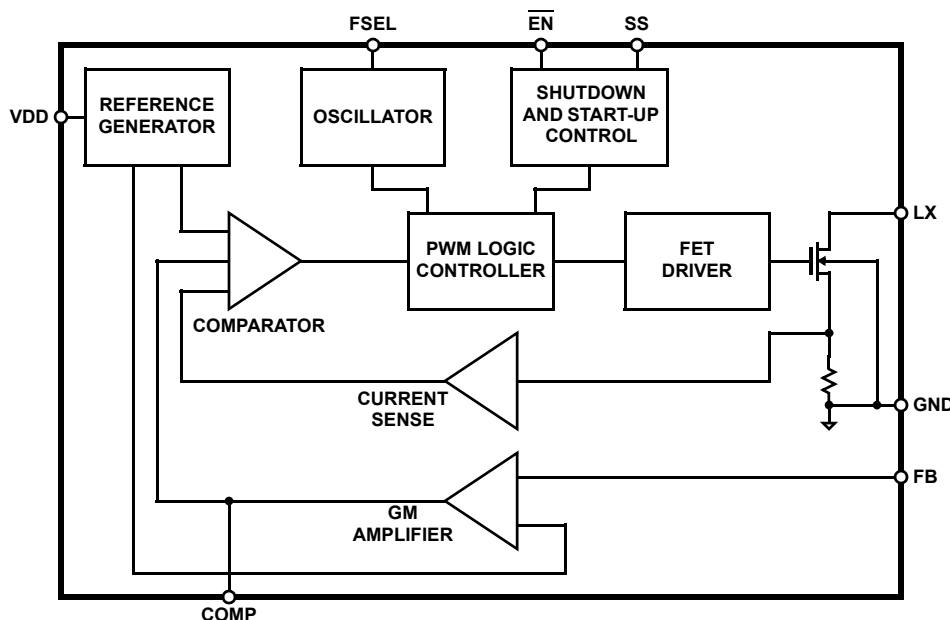
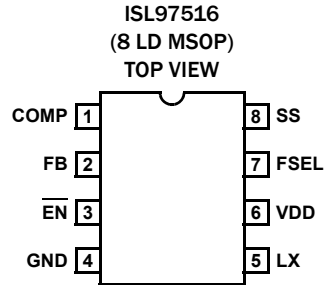

FIGURE 1. BLOCK DIAGRAM

## Pin Configuration



## Pin Descriptions

PIN NUMBER	PIN NAME	DESCRIPTION
1	COMP	Compensation pin. Output of the internal error amplifier. Capacitor and resistor from COMP pin to ground.
2	FB	Voltage feedback pin. Internal reference is 1.294V nominal. Connect a resistor divider from $V_{OUT}$ . $V_{OUT} = 1.294V (1 + R_1/R_2)$ . See "Typical Application Circuit" on page 2.
3	$\overline{EN}$	Shutdown control pin. Pull EN low to turn off the device.
4	GND	Analog and power ground.
5	LX	Power switch pin. Connected to the drain of the internal power MOSFET.
6	VDD	Analog power supply input pin.
7	FSEL	Frequency select pin. When FSEL is set low, switching frequency is set to 620kHz. When connected to high or $V_{DD}$ , switching frequency is set to 1.25MHz.
8	SS	Soft-start control pin. Connect a capacitor to control the converter start-up.

## Typical Application Circuit

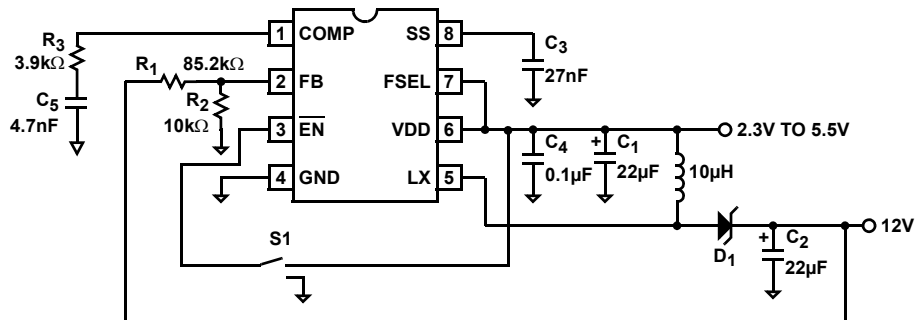

## Ordering Information

PART NUMBER (Notes 2, 3)	PART MARKING	PACKAGE (Pb-free)	PKG. DWG. #
ISL97516IUZ	7516Z	8 Ld MSOP	M8.118A
ISL97516IUZ-T (Note 1)	7516Z	8 Ld MSOP	M8.118A
ISL97516IUZ-TK (Note 1)	7516Z	8 Ld MSOP	M8.118A

### NOTES:

- Please refer to [TB347](#) for details on reel specifications.
- These Intersil Pb-free plastic packaged products employ special Pb-free material sets, molding compounds/die attach materials, and 100% matte tin plate plus anneal (e3 termination finish, which is RoHS compliant and compatible with both SnPb and Pb-free soldering operations). Intersil Pb-free products are MSL classified at Pb-free peak reflow temperatures that meet or exceed the Pb-free requirements of IPC/JEDEC J STD-020.
- For Moisture Sensitivity Level (MSL), please see device information page for [ISL97516](#). For more information on MSL please see techbrief [TB363](#).

**Absolute Maximum Ratings** ( $T_A = +25^\circ\text{C}$ )

LX to GND	27V
$V_{DD}$ to GND	6.5V
COMP, FB, EN, SS, FSEL to GND	-0.3V to ( $V_{DD} + 0.3V$ )

**Thermal Information**

Storage Temperature	-65°C to +150°C
Operating Ambient Temperature	-40°C to +85°C
Operating Junction Temperature	+135°C
Power Dissipation	See Curves
Pb-free Reflow Profile	see link below <a href="http://www.intersil.com/pbfree/Pb-FreeReflow.asp">http://www.intersil.com/pbfree/Pb-FreeReflow.asp</a>

CAUTION: Do not operate at or near the maximum ratings listed for extended periods of time. Exposure to such conditions may adversely impact product reliability and result in failures not covered by warranty.

IMPORTANT NOTE: All parameters having Min/Max specifications are guaranteed. Typical values are for information purposes only. Unless otherwise noted, all tests are at the specified temperature and are pulsed tests, therefore:  $T_J = T_C = T_A$

**Electrical Specifications**  $V_{IN} = 3.3V$ ,  $V_{OUT} = 12V$ ,  $I_{OUT} = 0mA$ , FSEL = GND,  $T_A = -40^\circ\text{C}$  to  $+85^\circ\text{C}$ . **Boldface limits apply over the operating temperature range, -40°C to +85°C.**

PARAMETER	DESCRIPTION	CONDITIONS	MIN (Note 4)	TYP	MAX (Note 4)	UNIT
IQ1	Quiescent Current - Shutdown	EN = 0V		1	5	$\mu\text{A}$
IQ2	Quiescent Current - Not Switching	EN = $V_{DD}$ , FB = 1.3V		0.7		mA
IQ3	Quiescent Current - Switching	EN = $V_{DD}$ , FB = 1.0V		3	4	mA
$V_{FB}$	Feedback Voltage		<b>1.272</b>	1.294	<b>1.309</b>	V
$I_{B-FB}$	Feedback Input Bias Current			0.01	<b>0.5</b>	$\mu\text{A}$
$V_{DD}$	Input Voltage Range		<b>2.3</b>		<b>5.5</b>	V
$D_{MAX} - 600\text{kHz}$	Maximum Duty Cycle	FSEL = 0V	<b>85</b>	92		%
$D_{MAX} - 1.2\text{MHz}$	Maximum Duty Cycle	FSEL = $V_{DD}$	<b>85</b>	90		%
$I_{LIM}$	Current Limit - Max Peak Input Current		<b>1.7</b>	2.0		A
$I_{EN}$	Shutdown Input Bias Current	EN = 0V		0.01	<b>0.5</b>	$\mu\text{A}$
$r_{DS(ON)}$	Switch ON-Resistance	$V_{DD} = 2.7V$ , $I_{LX} = 1A$		0.2		$\Omega$
$I_{LX-LEAK}$	Switch Leakage Current	VSW = 27V		0.01	<b>3</b>	$\mu\text{A}$
$\Delta V_{OUT}/\Delta V_{IN}$	Line Regulation	$3V < V_{IN} < 5.5V$ , $V_{OUT} = 12V$		0.2		%
$\Delta V_{OUT}/\Delta I_{OUT}$	Load Regulation	$V_{IN} = 3.3V$ , $V_{OUT} = 12V$ , $I_O = 30\text{mA}$ to 200mA		0.3		%
$f_{OSC1}$	Switching Frequency Accuracy	FSEL = 0V	<b>500</b>	620	<b>740</b>	kHz
$f_{OSC2}$	Switching Frequency Accuracy	FSEL = $V_{DD}$	<b>1000</b>	1250	<b>1500</b>	kHz
$V_{IL}$	EN, FSEL Input Low Level				<b>0.5</b>	V
$V_{IH}$	EN, FSEL Input High Level		<b>1.5</b>			V
$G_M$	Error Amp Transconductance	$\Delta I = 5\mu\text{A}$	<b>70</b>	130	<b>150</b>	$1\mu/\Omega$
$V_{DD-ON}$	$V_{DD}$ UVLO On Threshold		<b>2.1</b>	2.2	<b>2.3</b>	V
HYS	$V_{DD}$ UVLO Hysteresis			100		mV
$I_{SS}$	Soft-Start Charge Current		<b>4</b>	6	<b>8</b>	$\mu\text{A}$
OTP	Over-Temperature Protection			150		$^\circ\text{C}$

## NOTE:

4. Parameters with MIN and/or MAX limits are 100% tested at  $+25^\circ\text{C}$ , unless otherwise specified. Temperature limits established by characterization and are not production tested.

# Typical Performance Curves

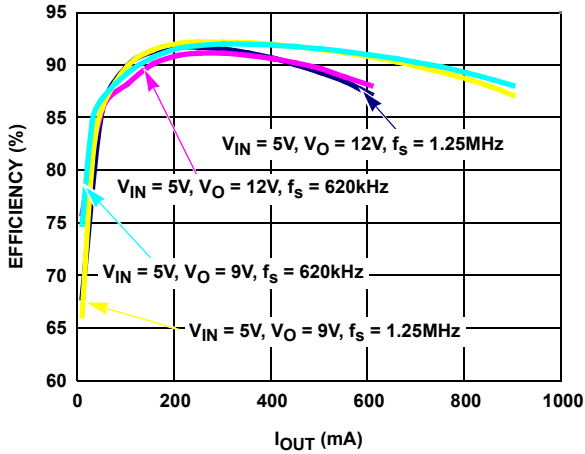

FIGURE 2. BOOST EFFICIENCY vs I<sub>OUT</sub>

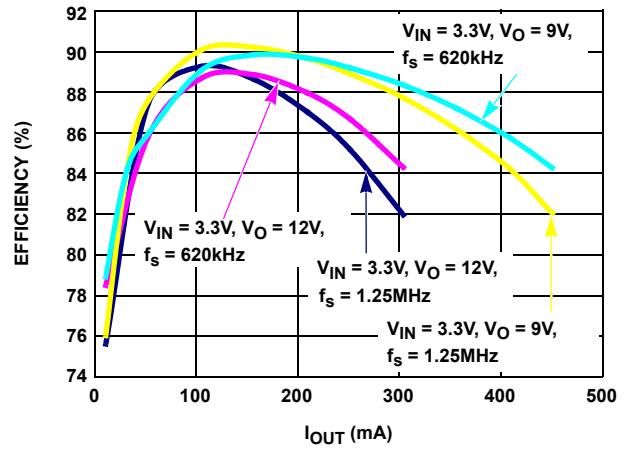

FIGURE 3. BOOST EFFICIENCY vs I<sub>OUT</sub>

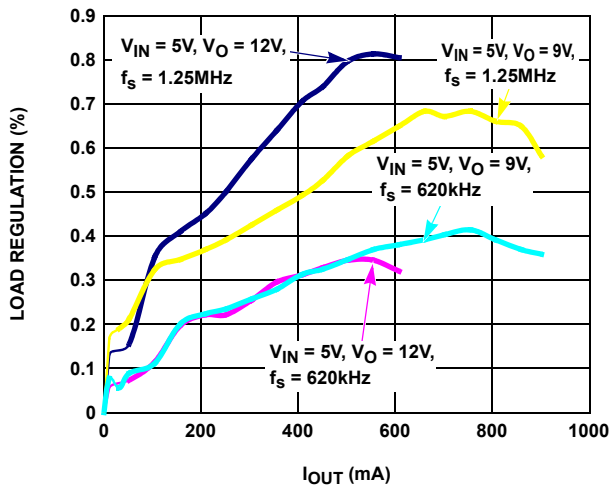

FIGURE 4. LOAD REGULATION vs I<sub>OUT</sub>

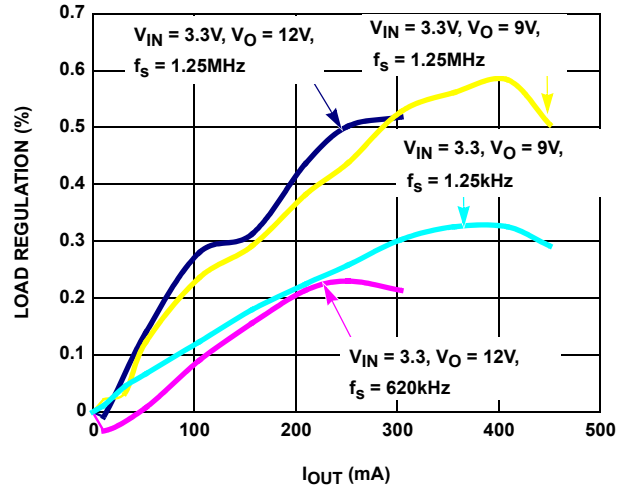

FIGURE 5. LOAD REGULATION vs I<sub>OUT</sub>

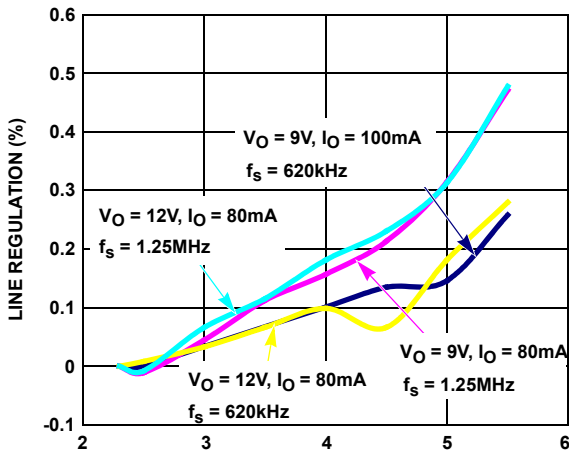

FIGURE 6. LINE REGULATION vs V<sub>IN</sub>

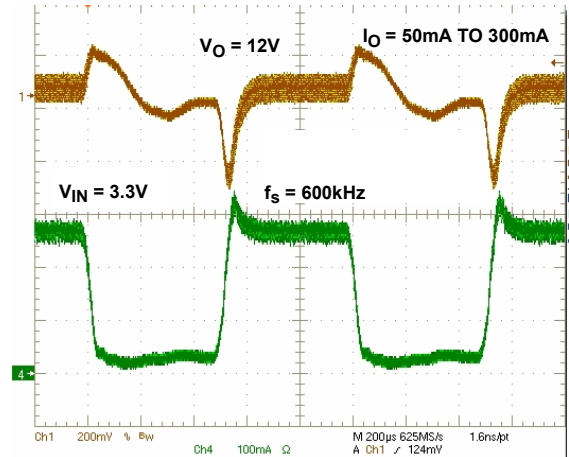

FIGURE 7. TRANSIENT RESPONSE

## Typical Performance Curves (Continued)

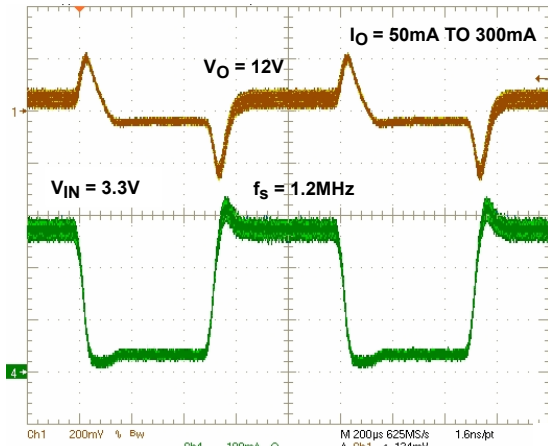

FIGURE 8. TRANSIENT RESPONSE

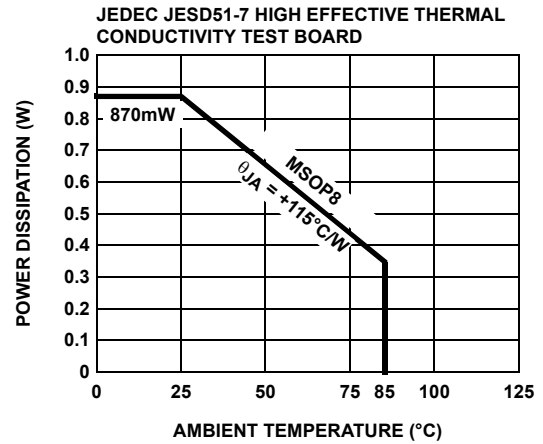

FIGURE 9. PACKAGE POWER DISSIPATION vs AMBIENT TEMPERATURE

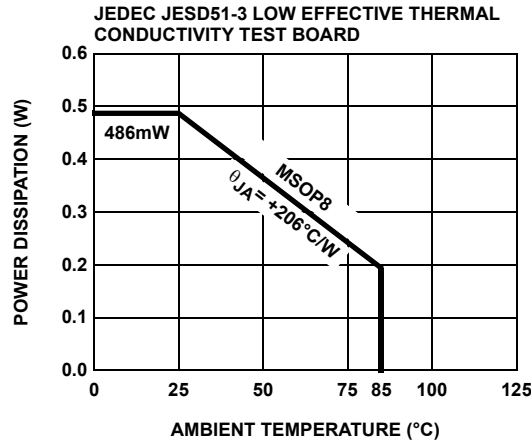

FIGURE 10. PACKAGE POWER DISSIPATION vs AMBIENT TEMPERATURE

## Applications Information

The ISL97516 is a high frequency, high efficiency boost regulator operated at constant frequency PWM mode. The boost converter stores energy from an input voltage source and deliver it to a higher output voltage. The input voltage range is 2.3V to 5.5V and output voltage range is 5V to 25V. The switching frequency is selectable between 600kHz and 1.2MHz allowing smaller inductors and faster transient response. An external compensation pin gives the user greater flexibility in setting output transient response and tighter load regulation. The converter soft-start characteristic can also be controlled by external  $C_{SS}$  capacitor. The  $\overline{EN}$  pin allows the user to completely shutdown the device.

### Boost Converter Operations

Figure 11 shows a boost converter with all the key components. In steady state operating and continuous conduction mode where the inductor current is continuous, the boost converter operates in two cycles. During the first cycle,

as shown in Figure 12, the internal power FET turns on and the Schottky diode is reverse biased and cuts off the current flow to the output. The output current is supplied from the output capacitor. The voltage across the inductor is  $V_{IN}$  and the inductor current ramps up in a rate of  $V_{IN}/L$ ,  $L$  is the inductance. The inductance is magnetized and energy is stored in the inductor. The change in inductor current is shown in Equation 1:

$$\Delta I_{L1} = \Delta t1 \times \frac{V_{IN}}{L}$$

$$\Delta t1 = \frac{D}{f_{SW}}$$

$D$  = Duty Cycle

$$\Delta V_O = \frac{I_{OUT}}{C_{OUT}} \times \Delta t1 \tag{EQ. 1}$$

During the second cycle, the power FET turns off and the Schottky diode is forward biased, (Figure 13). The energy stored in the inductor is pumped to the output supplying output current and charging the output capacitor. The Schottky diode side of the inductor is clamp to a Schottky diode above the output voltage. So the voltage drop across the inductor is  $V_{IN} - V_{OUT}$ . The change in inductor current during the second cycle is:

$$\Delta I_L = \Delta t_2 \times \frac{V_{IN} - V_{OUT}}{L}$$

$$\Delta t_2 = \frac{1-D}{f_{SW}} \tag{EQ. 2}$$

For stable operation, the same amount of energy stored in the inductor must be taken out. The change in inductor current during the two cycles must be the same.

$$\Delta I_1 + \Delta I_2 = 0$$

$$\frac{D}{f_{SW}} \times \frac{V_{IN}}{L} + \frac{1-D}{f_{SW}} \times \frac{V_{IN} - V_{OUT}}{L} = 0$$

$$\frac{V_{OUT}}{V_{IN}} = \frac{1}{1-D} \tag{EQ. 3}$$

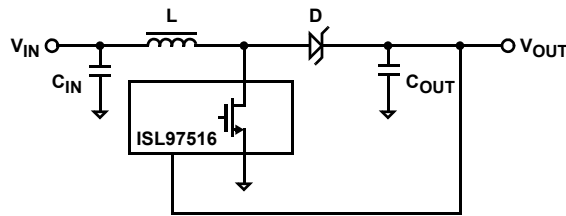

FIGURE 11. BOOST CONVERTER

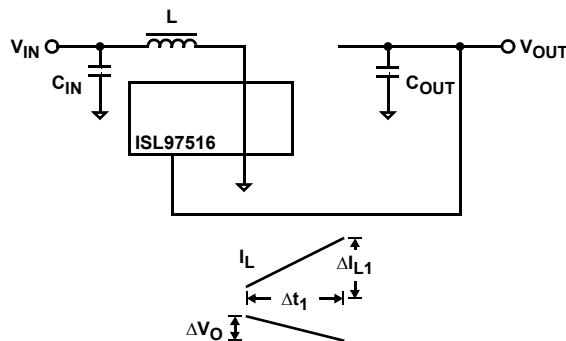

FIGURE 12. BOOST CONVERTER - CYCLE 1, POWER SWITCH CLOSED

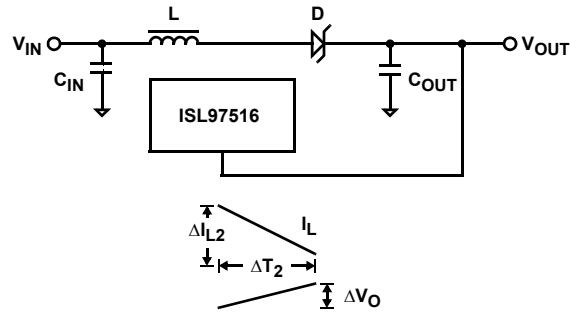

FIGURE 13. BOOST CONVERTER - CYCLE 2, POWER SWITCH OPEN

### Output Voltage

An external feedback resistor divider is required to divide the output voltage down to the nominal 1.294V reference voltage. The current drawn by the resistor network should be limited to maintain the overall converter efficiency. The maximum value of the resistor network is limited by the feedback input bias current and the potential for noise being coupled into the feedback pin. A resistor network less than 100k is recommended. The boost converter output voltage is determined by the relationship in Equation 4:

$$V_{OUT} = V_{FB} \times \left( 1 + \frac{R_1}{R_2} \right) \tag{EQ. 4}$$

The nominal VFB voltage is 1.294V.

### Inductor Selection

The inductor selection determines the output ripple voltage, transient response, output current capability, and efficiency. Its selection depends on the input voltage, output voltage, switching frequency, and maximum output current. For most applications, the inductance should be in the range of 2μH to 33μH. The inductor maximum DC current specification must be greater than the peak inductor current required by the regulator. The peak inductor current can be calculated using Equation 5:

$$I_{L(PEAK)} = \frac{I_{OUT} \times V_{OUT}}{V_{IN}} + 1/2 \times \frac{V_{IN} \times (V_{OUT} - V_{IN})}{L \times V_{OUT} \times \text{FREQ}} \tag{EQ. 5}$$

### Output Capacitor

Low ESR capacitors should be used to minimize the output voltage ripple. Multilayer ceramic capacitors (X5R and X7R) are preferred for the output capacitors because of their lower ESR and small packages. Tantalum capacitors with higher ESR can also be used. The output ripple can be calculated in Equation 6:

$$\Delta V_O = \frac{I_{OUT} \times D}{f_{SW} \times C_O} + I_{OUT} \times \text{ESR} \tag{EQ. 6}$$

For noise sensitive applications, a 0.1μF placed in parallel with the larger output capacitor is recommended to reduce the switching noise coupled from the LX switching node.

## Schottky Diode

In selecting the Schottky diode, the reverse break down voltage, forward current and forward voltage drop must be considered for optimum converter performance. The diode must be rated to handle 2.0A, the current limit of the ISL97516. The breakdown voltage must exceed the maximum output voltage. Low forward voltage drop, low leakage current, and fast reverse recovery will help the converter to achieve the maximum efficiency.

## Input Capacitor

The value of the input capacitor depends upon the input and output voltages, the maximum output current, the inductor value and the noise allowed to put back on the input line. For most applications, a minimum 10 $\mu$ F is required. For applications that run close to the maximum output current limit, input capacitor in the range of 22 $\mu$ F to 47 $\mu$ F is recommended.

The ISL97516 is powered from the VIN. A High frequency 0.1 $\mu$ F bypass capacitor is recommended to be close to the VIN pin to reduce supply line noise and ensure stable operation.

## Loop Compensation

The ISL97516 incorporates a transconductance amplifier in its feedback path to allow the user some adjustment on the transient response and better regulation. The ISL97516 uses current mode control architecture, which has a fast current sense loop and a slow voltage feedback loop. The fast current feedback loop does not require any compensation. The slow voltage loop must be compensated for stable operation. The compensation network is a series RC network from COMP pin to ground. The resistor sets the high frequency integrator gain for fast transient response and the capacitor sets the integrator zero to ensure loop stability. For most applications, the compensation resistor in the range of 2k to 7.5k and the compensation capacitor in the range of 3nF to 10nF.

## Soft-Start

The soft-start is provided by an internal 6 $\mu$ A current source which charges the external C<sub>SS</sub>; the peak MOSFET current is limited by the voltage on the capacitor. This in turn controls the rising rate of the output voltage. The regulator goes through the start-up sequence as well after the EN pin is pulled to HI. For most applications, the external C<sub>SS</sub> of 27nF is recommended.

## Frequency Selection

The ISL97516 switching frequency can be user selected to operate at either constant 620kHz or 1.25MHz. Connecting FSEL pin to ground sets the PWM switching frequency to 620kHz. When connecting FSEL high or VDD, the switching frequency is set to 1.25MHz.

## Shutdown Control

When the EN pin is pulled down, the ISL97516 is shutdown reducing the supply current to <1 $\mu$ A.

## Maximum Output Current

The MOSFET current limit is nominally 2.0A and guaranteed 1.7A. This restricts the maximum output current, I<sub>OMAX</sub>, based on Equation 7:

$$I_L = I_{L-AVG} + (1/2 \times \Delta I_L) \quad (\text{EQ. 7})$$

where:

I<sub>L</sub> = MOSFET current limit

I<sub>L-AVG</sub> = average inductor current

$\Delta I_L$  = inductor ripple current

$$\Delta I_L = \frac{V_{IN} \times [(V_O + V_{DIODE}) - V_{IN}]}{L \times (V_O + V_{DIODE}) \times f_S} \quad (\text{EQ. 8})$$

V<sub>DIODE</sub> = Schottky diode forward voltage, typically, 0.6V

f<sub>S</sub> = switching frequency, 600kHz or 1.2MHz

$$I_{L-AVG} = \frac{I_{OUT}}{1-D} \quad (\text{EQ. 9})$$

D = MOSFET turn-on ratio:

$$D = 1 - \frac{V_{IN}}{V_{OUT} + V_{DIODE}} \quad (\text{EQ. 10})$$

Table 1 gives typical maximum I<sub>OUT</sub> values for 1.2MHz switching frequency and 10 $\mu$ H inductor.

TABLE 1.

V <sub>IN</sub> (V)	V <sub>OUT</sub> (V)	I <sub>OMAX</sub> (mA)
2.5	5	870
2.5	9	500
2.5	12	380
3.3	5	1150
3.3	9	655
3.3	12	500
5	9	990
5	12	750

## Cascaded MOSFET Application

An 25V N-Channel MOSFET is integrated in the boost regulator. For the applications where the output voltage is greater than 25V, an external cascaded MOSFET is needed as shown in Figure 13. The voltage rating of the external MOSFET should be greater than A<sub>VDD</sub>.

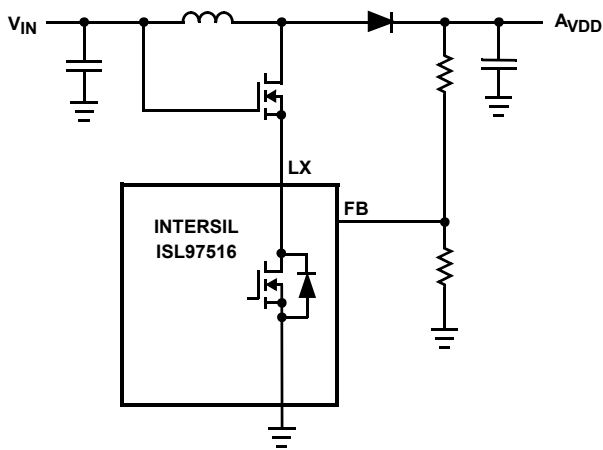

FIGURE 14. CASCADED MOSFET TOPOLOGY FOR HIGH OUTPUT VOLTAGE APPLICATIONS

### DC PATH BLOCK APPLICATION

Note that there is a DC path in the boost converter from the input to the output through the inductor and diode, hence the input voltage will be seen at output with a forward voltage drop of diode before the part is enabled. If this voltage is not desired, the following circuit can be inserted between input and inductor to disconnect the DC path when the part is disabled.

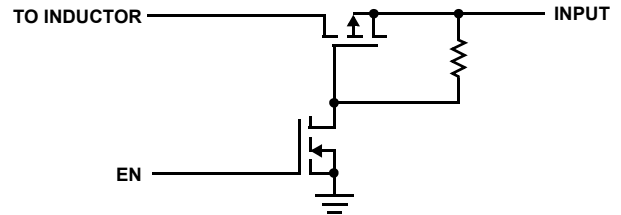

FIGURE 15. CIRCUIT TO DISCONNECT THE DC PATH OF BOOST CONVERTER

© Copyright Intersil Americas LLC 2006-2014. All Rights Reserved.  
All trademarks and registered trademarks are the property of their respective owners.

For additional products, see [www.intersil.com/en/products.html](http://www.intersil.com/en/products.html)

Intersil products are manufactured, assembled and tested utilizing ISO9001 quality systems as noted in the quality certifications found at [www.intersil.com/en/support/qualandreliability.html](http://www.intersil.com/en/support/qualandreliability.html)

*Intersil products are sold by description only. Intersil may modify the circuit design and/or specifications of products at any time without notice, provided that such modification does not, in Intersil's sole judgment, affect the form, fit or function of the product. Accordingly, the reader is cautioned to verify that datasheets are current before placing orders. Information furnished by Intersil is believed to be accurate and reliable. However, no responsibility is assumed by Intersil or its subsidiaries for its use; nor for any infringements of patents or other rights of third parties which may result from its use. No license is granted by implication or otherwise under any patent or patent rights of Intersil or its subsidiaries.*

For information regarding Intersil Corporation and its products, see [www.intersil.com](http://www.intersil.com)

# Package Outline Drawing

## M8.118A

8 LEAD MINI SMALL OUTLINE PLASTIC PACKAGE (MSOP)

Rev 0, 9/09

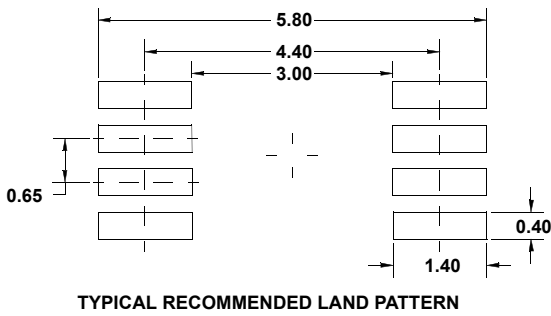
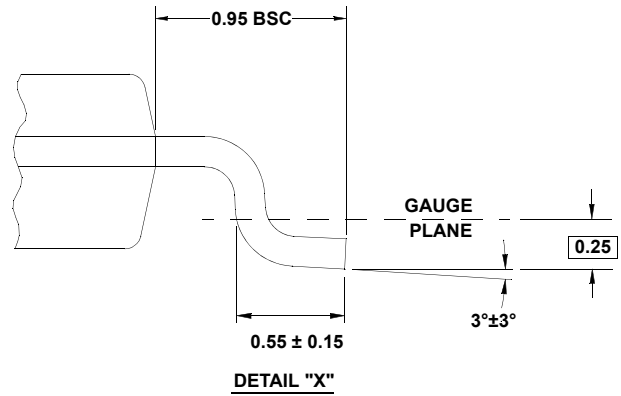
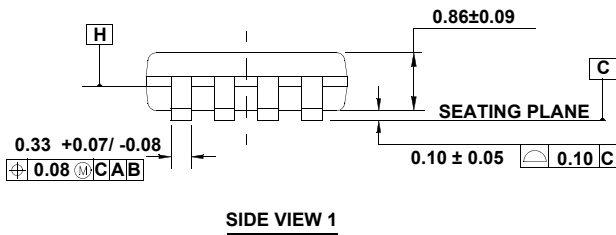
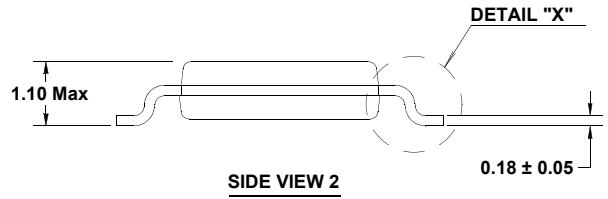
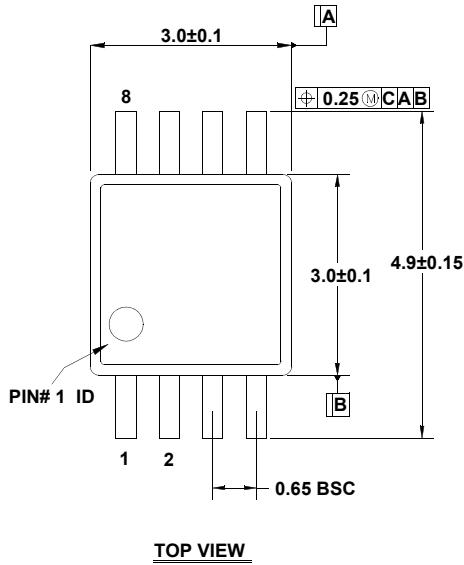

**NOTES:**

1. Dimensions are in millimeters.
2. Dimensioning and tolerancing conform to JEDEC MO-187-AA and AMSE Y14.5m-1994.
3. Plastic or metal protrusions of 0.15mm max per side are not included.
4. Plastic interlead protrusions of 0.25mm max per side are not included.
5. Dimensions "D" and "E1" are measured at Datum Plane "H".
6. This replaces existing drawing # MDP0043 MSOP 8L.

## Looking for pricing, stock, or lifecycle information?

Click below to explore more details on WIN SOURCE:

 [View ISL97516IUZEVALZ on WIN SOURCE](#)

 [Intersil Information](#)

## Optimize Your Supply Chain with WIN SOURCE Solutions

-  Global Sourcing Solution
-  Obsolete Management
-  Cost Control Management
-  Shortage Management
-  Alternative Solution
-  Excess Inventory Management