



**THE DATASHEET OF  
ISL94203IRTZ-T7A**



ISL94203

3-to-8 Cell Li-ion Battery Pack Monitor

FN7626  
 Rev.6.00  
 Apr 26, 2019

The **ISL94203** is a Li-ion battery monitor IC that supports from 3 to 8 series connected cells. It provides full battery monitoring and pack control. The ISL94203 provides automatic shutdown and recovery from out of bounds conditions and automatically controls pack cell balancing.

The ISL94203 is highly configurable as a stand-alone unit, but can be used with an external microcontroller, which communicates to the IC through an I<sup>2</sup>C interface.

**Applications**

- Power tools
- Battery back-up systems
- E-bikes

**Related Literature**

- [AN1952](#), "ISL94203EVKIT1Z Evaluation Kit User Guide"

**Features**

- Eight cell voltage monitors support Li-ion CoO<sub>2</sub>, Li-ion Mn<sub>2</sub>O<sub>4</sub> and Li-ion FePO<sub>4</sub> chemistries
- Stand-alone pack control - no microcontroller needed
- Multiple voltage protection options (each programmable to 4.8V; 12-bit digital value) and selectable overcurrent protection levels
- Programmable detection/recovery times for overvoltage, undervoltage, overcurrent and short-circuit conditions
- Configuration/calibration registers maintained in EEPROM
- Open battery connect detection
- Integrated charge/discharge FET drive circuitry with built-in charge pump supports high-side N-channel FETs
- Cell balancing uses external FETs with internal state machine or external microcontroller
- Enters low power states after periods of inactivity. Charge or discharge current detection resumes normal scan rates

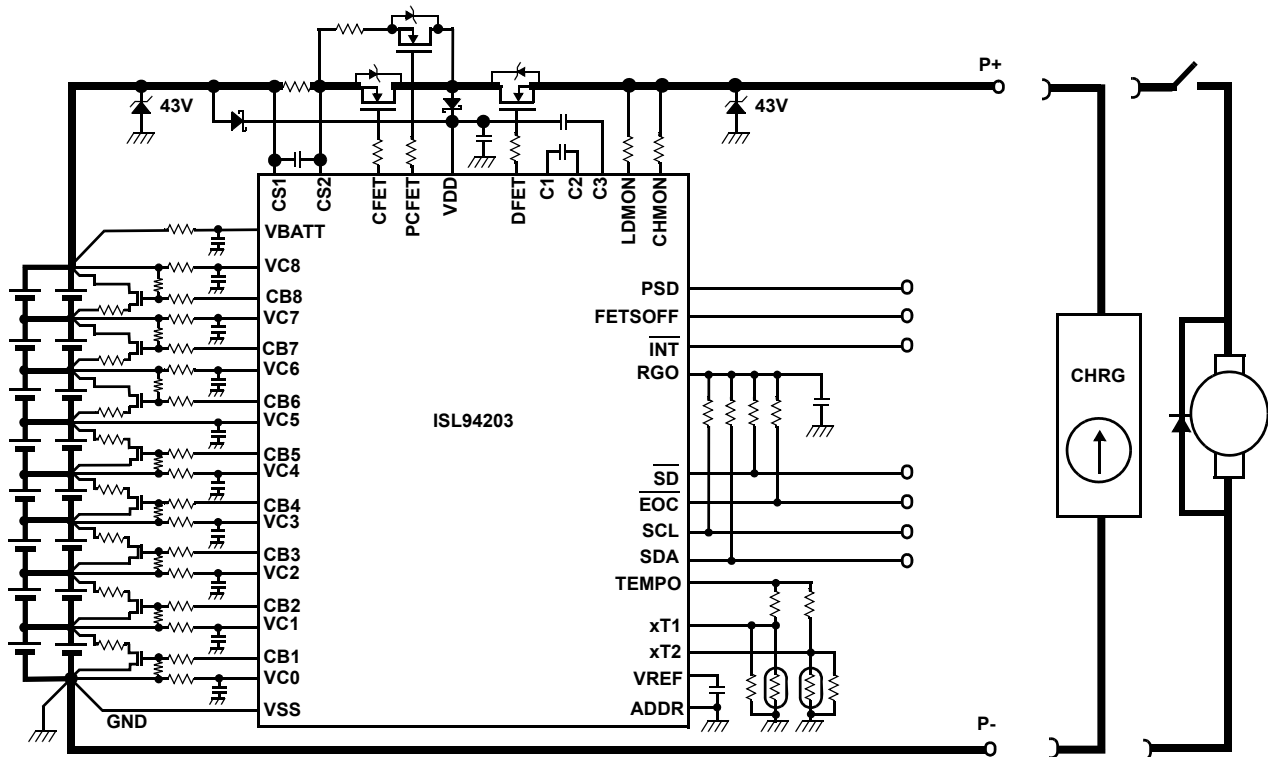

FIGURE 1. TYPICAL APPLICATION DIAGRAM

# Table of Contents

<b>Ordering Information</b> .....	<b>4</b>
<b>Pin Configuration</b> .....	<b>4</b>
<b>Pin Descriptions</b> .....	<b>5</b>
<b>Block Diagram</b> .....	<b>7</b>
<b>Absolute Maximum Ratings</b> .....	<b>8</b>
<b>Thermal Information</b> .....	<b>8</b>
<b>Recommended Operating Conditions</b> .....	<b>8</b>
<b>Electrical Specifications</b> .....	<b>8</b>
<b>Symbol Table</b> .....	<b>16</b>
<b>Timing Diagrams</b> .....	<b>16</b>
External Temperature Configuration .....	16
Wake-Up Timing .....	16
Power-Up Timing .....	17
Change in FET Control .....	17
Automatic Temperature Scan .....	18
Serial Interface Timing Diagrams .....	18
Discharge Overcurrent/Short-Circuit Monitor .....	19
Charge Overcurrent Monitor .....	19
<b>Functional Description</b> .....	<b>20</b>
<b>Battery Connections</b> .....	<b>20</b>
Power Path .....	20
Pack Configuration .....	20
Battery Cell Connections .....	20
<b>Operating Modes</b> .....	<b>21</b>
Power-Up Operation .....	21
Wake-Up Circuit .....	23
Low Power States .....	23
<b>Typical Operating Conditions</b> .....	<b>24</b>
<b>Cell Fail Detection</b> .....	<b>24</b>
<b>Open-Wire Detection</b> .....	<b>25</b>
<b>Current and Voltage Monitoring</b> .....	<b>27</b>
Current Monitor .....	27
Current Sense .....	27
Overcurrent and Short-Circuit Detection .....	28
Overcurrent and Short-Circuit Response (Discharge) .....	29
Overcurrent Response (Charge) .....	29
Microcontroller Overcurrent FET Control Protection .....	30
Voltage, Temperature and Current Scan .....	31
Cell Voltage Monitoring .....	32
Overvoltage Detection/Response .....	33
Undervoltage Detection/Response .....	34
Temperature Monitoring/Response .....	35
Microcontroller Read of Voltages .....	37
Voltage Conversions .....	37
<b>Microcontroller FET Control</b> .....	<b>38</b>
<b>Cell Balance</b> .....	<b>38</b>
$\mu$ C Control of Cell Balance FETs .....	40
Cell Balance FET Drive .....	41
<b>Watchdog Timer</b> .....	<b>42</b>
<b>Power FET Drive</b> .....	<b>42</b>
<b>General I/Os</b> .....	<b>42</b>
<b>Higher Voltage Microcontrollers</b> .....	<b>42</b>

---

<b>Packs with Fewer than 8 Cells</b> .....	<b>43</b>
<b>PC Board Layout</b> .....	<b>44</b>
QFN Package .....	44
Circuit Diagrams .....	44
<b>EEPROM</b> .....	<b>44</b>
<b>Serial Interface</b> .....	<b>45</b>
Serial Interface Conventions .....	45
Clock and Data .....	45
Start Condition .....	45
Stop Condition .....	45
Acknowledge .....	45
Write Operations .....	46
Read Operations .....	48
Synchronizing Microcontroller Operations with Internal Scan .....	49
<b>Register Protection</b> .....	<b>49</b>
<b>Registers: Summary (EEPROM)</b> .....	<b>50</b>
<b>Registers: Summary (RAM)</b> .....	<b>50</b>
<b>Registers: Detailed (EEPROM)</b> .....	<b>51</b>
<b>Registers: Detailed (RAM)</b> .....	<b>58</b>
<b>Revision History</b> .....	<b>63</b>
<b>Package Outline Drawing</b> .....	<b>64</b>

## Ordering Information

PART NUMBER (Notes 2, 3)	PART MARKING	TEMP. RANGE (°C)	TAPE AND REEL (UNITS) (Note 1)	PACKAGE (RoHS Compliant)	PKG. DWG. #
ISL94203IRTZ	94203 IRTZ	-40 to +85	-	48 Ld TQFN	L48.6x6
ISL94203IRTZ-T7	94203 IRTZ	-40 to +85	1k	48 Ld TQFN	L48.6x6
ISL94203IRTZ-T	94203 IRTZ	-40 to +85	4k	48 Ld TQFN	L48.6x6
ISL94203IRTZ-T7A	94203 IRTZ	-40 to +85	250	48 Ld TQFN	L48.6x6
ISL94203EVKIT1Z	Evaluation Kit				

### NOTES:

- Please refer to [TB347](#) for details on reel specifications.
- These Pb-free plastic packaged products employ special Pb-free material sets, molding compounds/die attach materials and 100% matte tin plate plus anneal (e3 termination finish, which is RoHS compliant and compatible with both SnPb and Pb-free soldering operations). Pb-free products are MSL classified at Pb-free peak reflow temperatures that meet or exceed the Pb-free requirements of IPC/JEDEC J STD-020.
- For Moisture Sensitivity Level (MSL), please see device information page for [ISL94203](#). For more information on MSL please see tech brief [TB363](#).

## Pin Configuration

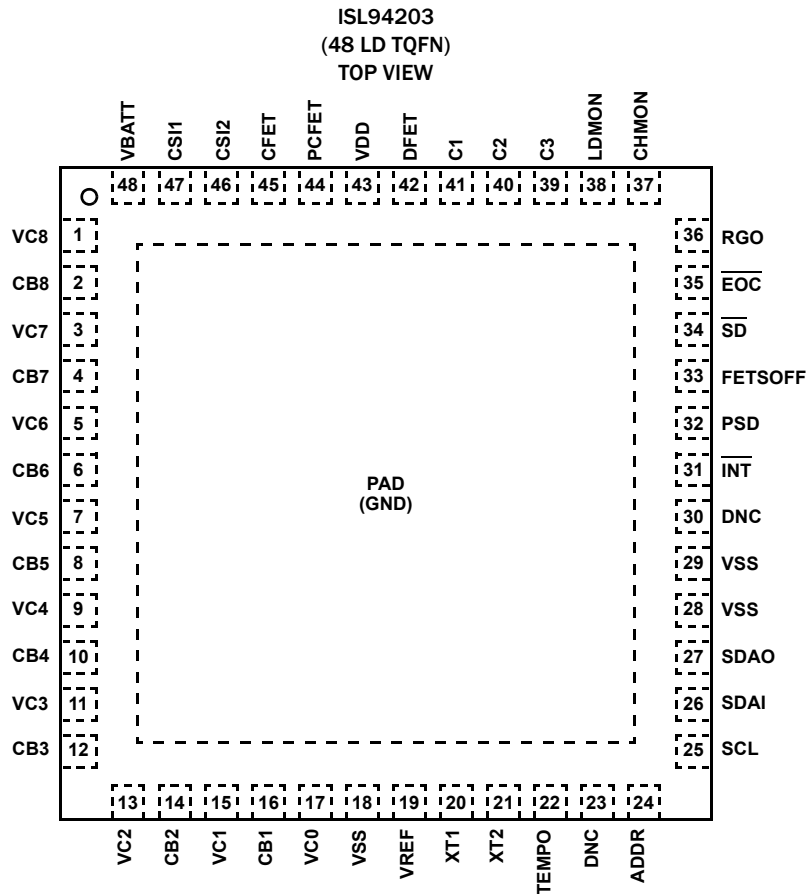

## Pin Descriptions

PIN NUMBER	SYMBOL	DESCRIPTION
1, 3, 5, 7, 9, 11, 13, 15, 17	VC8, VC7, VC6, VC5, VC4, VC3, VC2, VC1, VC0	<b>Battery cell n voltage input.</b> This pin is used to monitor the voltage of this battery cell. The voltage is level shifted to a ground reference and is monitored internally by an ADC converter. VCn connects to the positive terminal of a battery cell (CELLN) and VC(n-1) the negative terminal of CELLN (VSS connects with the negative terminal of CELL1).
2, 4, 6, 8, 10, 12, 14, 16	CB8, CB7, CB6, CB5, CB4, CB3, CB2, CB1	<b>Cell balancing FET control output n.</b> This internal drive circuit controls an external FET used to divert a portion of the current around a cell while the cell is being charged or adds to the current pulled from a cell during discharge in order to perform a cell voltage balancing operation. This function is generally used to reduce the voltage on an individual cell relative to other cells in the pack. The cell balancing FETs are turned on or off by an internal cell balance state machine or an external controller.
18, 28, 29	VSS	<b>Ground.</b> This pin connects to the most negative terminal in the battery string.
19	VREF	<b>Voltage Reference Output.</b> This output provides a 1.8V reference voltage for the internal circuitry and for the external microcontroller.
20, 21	XT1, XT2	<b>Temperature monitor inputs.</b> These pins input the voltage across two external thermistors used to determine the temperature of the cells and or the power FET. When this input drops below the threshold, an external over-temperature condition exists.
22	TEMPO	<b>Temperature monitor output control.</b> This pin outputs a voltage to be used in a divider that consists of a fixed resistor and a thermistor. The thermistor is located in close proximity to the cells or the power FET. The TEMPO output is connected internally to the VREF voltage through a PMOS switch only during a measurement of the temperature, otherwise the TEMPO output is off.
23, 30	DNC	Do Not Connect
24	ADDR	<b>Serial Address.</b> This is an address input for an I <sup>2</sup> C communication link to allow for two devices on one bus.
25	SCL	<b>Serial Clock.</b> This is the clock input for an I <sup>2</sup> C communication link.
26, 27	SDAI, SDAO	<b>Serial Data.</b> These are the data lines for an I <sup>2</sup> C interface. When connected together, they form the standard bidirectional interface for the I <sup>2</sup> C bus.
31	$\overline{\text{INT}}$	<b>Interrupt.</b> This pin goes active low, when there is an external $\mu\text{C}$ connected to the ISL94203 and $\mu\text{C}$ communication fails to send a slave byte within a watchdog timer period. This is a CMOS type output.
32	PSD	<b>Pack Shutdown.</b> This pin goes active high, when any cell voltage reaches the OVLO threshold (OVLO flag). Optionally, PSD is also set if there is a voltage differential between any two cells that is greater than a specified limit (CELLF flag) or if there is an open-wire condition. This pin can be used for blowing a fuse in the pack or as an interrupt to an external $\mu\text{C}$ .
33	FETSOFF	<b>FETSOFF.</b> This input allows an external microcontroller to turn off both Power FET and CB outputs. This pin should be pulled low when inactive.
34	$\overline{\text{SD}}$	<b>Shutdown.</b> This output indicates that the ISL94203 detected any failure condition that would result in the DFET turning off. This could be undervoltage, overcurrent, over-temperature, under-temperature, etc. The $\overline{\text{SD}}$ pin also goes active if there is any charge overcurrent condition. This is an open-drain output.
35	$\overline{\text{EOC}}$	<b>End-of-Charge.</b> This output indicates that the ISL94203 detected a fully charged condition. This is defined by any cell voltage exceeding an EOC voltage (as defined by an EOC value in EEPROM).
36	RG0	<b>Regulator Output.</b> This is the 2.5V regulator output.
37	CHMON	<b>Charge Monitor.</b> This input monitors the charger connection. When the IC is in the Sleep mode, connecting this pin to the charger wakes up the device. When the IC recovers from a charge overcurrent condition, this pin is used to monitor that the charger is removed prior to turning on the power FETs. In a single path configuration, this pin and the LDMON pin connect together.
38	LDMON	<b>Load Monitor.</b> This pin monitors the load connection. When the IC is in the Sleep mode, connecting this pin to a load wakes up the device. When the IC recovers from a discharge overcurrent or short-circuit condition, this pin is used to monitor that the load is removed prior to turning on the power FETs. In a single path configuration, this pin and the CHMON pin connect together.
39, 40, 41	C3, C2, C1	<b>Charge Pump Capacitor Pins.</b> These external capacitors are used for the charge pump driving the power FETs.

## Pin Descriptions (Continued)

PIN NUMBER	SYMBOL	DESCRIPTION
42	DFET	<b>Discharge FET Control.</b> The ISL94203 controls the gate of a discharge FET through this pin. The power FET is an N-channel device. The FET is turned on by the ISL94203 if all conditions are acceptable. The ISL94203 will turn off the FET in the event of an out of bounds condition. The FET can be turned off by an external microcontroller by writing to the CFET control bit. The CFET output is also turned off by the FETSOFF pin. The FET output cannot be turned on by an external microcontroller if there are any out of bounds conditions.
43	VDD	<b>IC Supply Pin.</b> This pin provides the operating voltage for the IC circuitry.
44	PCFET	<b>Precharge FET Control.</b> The ISL94203 controls the gate of a precharge FET through this pin. The power FET is an N-channel device. The FET is turned on by the ISL94203 if all conditions are acceptable. The ISL94203 will turn off the FET in the event of an out of bounds condition. The FET can be turned off by an external microcontroller by writing to the PCFET control bit. The PCFET output is also turned off by the FETSOFF pin. The FET output cannot be turned on by an external microcontroller if there are any out of bounds conditions. Either the PCFET or the CFET turn on, but not both.
45	CFET	<b>Charge FET Control.</b> The ISL94203 controls the gate of a charge FET through this pin. The power FET is an N-channel device. The FET is turned on by the ISL94203 if all conditions are acceptable. The ISL94203 will turn off the FET in the event of an out of bounds condition. The FET can be turned off by an external microcontroller by writing to the CFET control bit. The CFET output is also turned off by the FETSOFF pin. The FET output cannot be turned on by an external microcontroller if there are any out of bounds conditions. Either the PCFET or the CFET turn on, but not both.
46, 47	CSI2, CSI1	<b>Current Sense Inputs.</b> These pins connect to the ISL94203 current sense circuit. There is an external resistance across which the circuit operates. The sense resistor is typically in the range of 0.2mΩ to 5mΩ.
48	VBATT	<b>Input Level Shifter Supply and Battery pack voltage input.</b> This pin powers the input level shifters and is also used to monitor the voltage of the battery stack. The voltage is internally divided by 32 and connected to an ADC converter through a MUX.
PAD	GND	<b>Thermal Pad.</b> This pad should connect to ground.

# Block Diagram

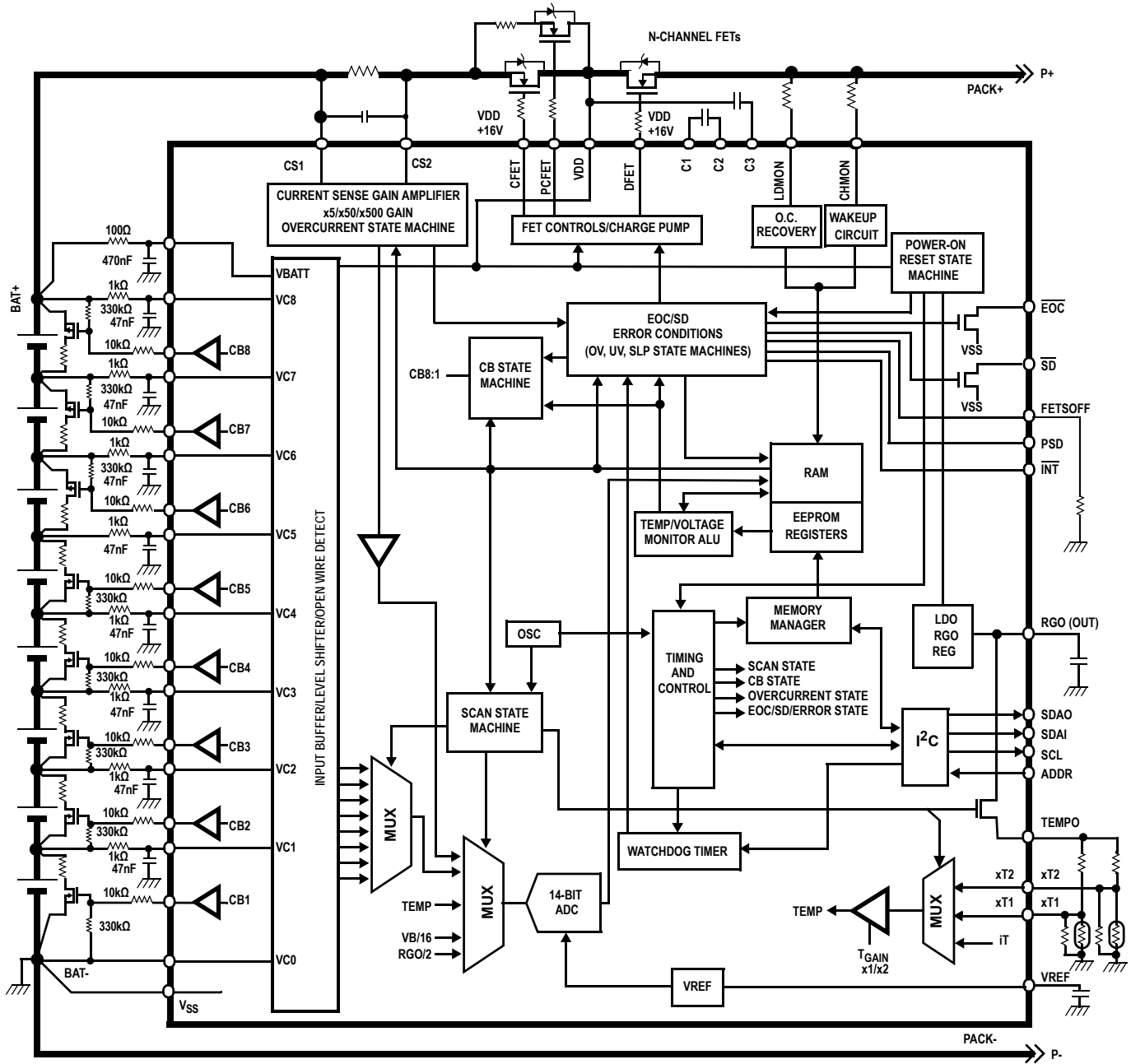

FIGURE 2. BLOCK DIAGRAM

**Absolute Maximum Ratings** (Note 4)

Power Supply Voltage, $V_{DD}$	$V_{SS} - 0.5V$ to $V_{SS} + 45.0V$
Cell Voltage (VC, VBATT)	
VCn	-0.5V to $V_{BATT} + 0.5V$
VCn - VSS (n = 8)	-0.5V to 45.0V
VCn - VSS (n = 6, 7)	-0.5V to 36.0V
VCn - VSS (n = 4, 5)	-0.5V to 27.0V
VCn - VSS (n = 2, 3)	-0.5V to 17.0V
VCn - VSS (n = 1)	-0.5V to 7.0V
VCn - VSS (n = 0)	-0.5V to 3.0V
VCn - VC(n-1) (n = 2 to 12)	-3.0V to 7.0V
VC1 - VC0	-0.5V to 7.0V
Cell Balance Pin Voltages (VCB)	
VCBn - VCn-1, n = 1 to 5	-0.5V to 7.0V
VCn - VCBn, n = 6 to 8	-0.5V to 7.0V
Terminal Voltage	
ADDR, xT1, xT2, FETSOFF, PSD, INT	-0.5 to $V_{RGO} + 0.5V$
SCL, SDAI, SDA0, EOC, SD	-0.5 to 5.5V
CFET, PCFET, C1, C2, C3	$V_{DD} - 0.5V$ to $V_{DD} + 15.5V$ (60V maximum)
DFET, CHMON, LDMON	-0.5V to $V_{DD} + 15.0V$ (60V maximum)
Current Sense Voltage	
VBATT, CS1, CS2	-0.5V to $V_{DD} + 1.0V$
VBATT - CS1, VBATT - CS2	-0.5V to +0.5V
CS1 - CS2	-0.5V to +0.5V
ESD Rating	
Human Body Model (Tested per JESD22-A114F)	2kV
Charged Device Model (Tested per JESD22-C101F)	1kV
Latch-Up (Tested per JESD-78D; Class 2, Level A)	100mA

**CAUTION:** Do not operate at or near the maximum ratings listed for extended periods of time. Exposure to such conditions may adversely impact product reliability and result in failures not covered by warranty.

## NOTES:

- Devices are characterized, but not production tested, at Absolute Maximum Voltages.
- $\theta_{JA}$  is measured in free air with the component mounted on a high effective thermal conductivity test board with "direct attach" features. See Tech Brief [TB379](#).
- For  $\theta_{JC}$ , the "case temp" location is the center of the exposed metal pad on the package underside.

**Thermal Information**

Thermal Resistance (Typical)	$\theta_{JA}$ ( $^{\circ}C/W$ )	$\theta_{JC}$ ( $^{\circ}C/W$ )
48 Ld QFN (Notes 5, 6)	28	0.75
Continuous Package Power Dissipation	.400mW	
Maximum Junction Temperature	+125 $^{\circ}C$	
Storage Temperature Range	-55 $^{\circ}C$ to +125 $^{\circ}C$	
Pb-Free Reflow Profile	see <a href="#">TB493</a>	

**Recommended Operating Conditions**

Temperature Range	-40 $^{\circ}C$ to +85 $^{\circ}C$
Operating Voltage:	
$V_{DD}$	4V to 36V
VCn-VC(n-1) Specified Range	2.0V to 4.3V
VCn-VC(n-1) Extended Range	1.0V to 4.4V
VCn-VC(n-1) Maximum Range (any cell)	0.5V to 4.8V

**Electrical Specifications**  $V_{DD} = 26.4V$ ,  $T_A = -40^{\circ}C$  to +85 $^{\circ}C$ , unless otherwise specified. **Boldface specification limits apply across operating temperature range, -40 $^{\circ}C$  to +85 $^{\circ}C$ .**

PARAMETER	SYMBOL	TEST CONDITIONS	MIN (Note 7)	TYP	MAX (Note 7)	UNIT
Power-up Condition – Threshold Rising (Device becomes Operational)	VPORR1	$V_{DD}$ minimum voltage at which device operation begins (CFET turns on; CHMON = $V_{DD}$ )		6.0		V
	VPORR2	CHMON minimum voltage at which device operation begins (CFET turns on; $V_{DD} > 6.0V$ )		VDD		V
Power-Down Condition – Threshold Falling	VPORF	$V_{DD}$ minimum voltage device remains operational (RGO turns off)		3.0		V
2.5V Regulated Voltage	$V_{RGO}$	$I_{RGO} = 3mA$	<b>2.4</b>	2.5	<b>2.6</b>	V
1.8V Reference Voltage	$V_{REF}$		<b>1.79</b>	1.8	<b>1.81</b>	V
VBATT Input Current - $V_{BATT}$	$I_{VBATT}$	Input current; Normal/Idle/Doze $V_{DD} = 33.6V$		38	<b>45</b>	$\mu A$
		Input current; Sleep/Power-Down $V_{DD} = 33.6V$			<b>1</b>	$\mu A$

**Electrical Specifications**  $V_{DD} = 26.4V$ ,  $T_A = -40^\circ C$  to  $+85^\circ C$ , unless otherwise specified. **Boldface specification limits apply across operating temperature range,  $-40^\circ C$  to  $+85^\circ C$ .** (Continued)

PARAMETER	SYMBOL	TEST CONDITIONS	MIN (Note 7)	TYP	MAX (Note 7)	UNIT
$V_{DD}$ Supply Current	$I_{VDD1}$	Device active (Normal mode) (No error conditions) CFET, PCFET, DFET = OFF; $V_{DD} = 33.6V$		310	<b>370</b>	$\mu A$
	$I_{VDD2}$	Device active (Idle mode) (No error conditions) Idle = 1 CFET, PCFET, DFET = OFF; $V_{DD} = 33.6V$		215	<b>275</b>	$\mu A$
	$I_{VDD3}$	Device active (Doze mode) (No error conditions) Doze = 1 CFET, PCFET, DFET = OFF; $V_{DD} = 33.6V$		210	<b>265</b>	$\mu A$
	$I_{VDD4}$	FET Drive Current ( $I_{VDD}$ increase when FETs are on - Normal/Idle/Doze modes); $V_{DD} = 33.6V$		215		$\mu A$
	$I_{VDD5}$	Device active (Sleep mode); Sleep = 1; $V_{DD} = 33.6V$  $0^\circ C$ to $+60^\circ C$ $-40^\circ C$ to $+85^\circ C$		13	<b>30</b> <b>50</b>	$\mu A$
	$I_{VDD6}$	Power-down PDWN = 1; $V_{DD} = 33.6V$			<b>1</b>	$\mu A$
Input Bias Current	ICS1	$V_{DD} = V_{BATT} = V_{CS1} = V_{CS2} = 33.6V$ (Normal, idle, doze)		10	<b>15</b>	$\mu A$
		$V_{DD} = V_{BATT} = V_{CS1} = V_{CS2} = 33.6V$ (Sleep, Power-Down)  $0^\circ C$ to $+60^\circ C$ $-40^\circ C$ to $+85^\circ C$			<b>1</b> <b>3</b>	$\mu A$
	ICS2	$V_{DD} = V_{BATT} = V_{CS1} = V_{CS2} = 33.6V$ (Normal, Idle, Doze)		10	<b>15</b>	$\mu A$
		$V_{DD} = V_{BATT} = V_{CS1} = V_{CS2} = 33.6V$ (Sleep, Power-Down)  $0^\circ C$ to $+60^\circ C$ $-40^\circ C$ to $+85^\circ C$			<b>1</b> <b>3</b>	$\mu A$
$V_{CN}$ Input Current	$I_{VCN}$	Cell input leakage current A02:A00 = 0000H (Normal/Idle/Doze; not sampling cells)	<b>-1</b>		<b>1</b>	$\mu A$
$C_{BN}$ Input Current	$I_{CBN}$	Cell Balance pin leakage current (no balance active)	<b>-1</b>		<b>1</b>	$\mu A$

**TEMPERATURE MONITOR SPECIFICATIONS**

External Temperature Accuracy	$V_{XT1}$	External temperature monitoring error. ADC voltage error when monitoring xT1 input. TGain = 0; (xTn = 0.2V to 0.737V)	<b>-25</b>		<b>15</b>	mV
Internal Temperature Monitor Output (See <a href="#">"Temperature Monitoring/Response" on page 35</a> )	$T_{INT25}$	$[iTB:iTO]_{10} * 1.8 / 4095 / GAIN$ GAIN = 2 (TGain bit = 0) Temperature = $+25^\circ C$		0.276		V
	$V_{INTMON}$	Change in $[iTB:iTO]_{10} * 1.8 / 4095 / GAIN$ GAIN = 2 (TGain bit = 0) Temperature = $-40^\circ C$ to $+85^\circ C$		1.0		mV/ $^\circ C$

**Electrical Specifications**  $V_{DD} = 26.4V$ ,  $T_A = -40^\circ C$  to  $+85^\circ C$ , unless otherwise specified. **Boldface specification limits apply across operating temperature range,  $-40^\circ C$  to  $+85^\circ C$ .** (Continued)

PARAMETER	SYMBOL	TEST CONDITIONS	MIN (Note 7)	TYP	MAX (Note 7)	UNIT
<b>CELL VOLTAGE MONITOR SPECIFICATIONS</b>						
Cell Monitor Voltage Accuracy	$V_{ADCR}$	Relative cell measurement error (Maximum absolute cell measurement error - Minimum absolute cell measurement error) $V_{Cn} - V_{C(n-1)} = 2.4V$ to $4.2V$ ; $0^\circ C$ to $+60^\circ C$ $V_{Cn} - V_{C(n-1)} = 0.1V$ to $4.7V$ ; $0^\circ C$ to $+60^\circ C$ $V_{Cn} - V_{C(n-1)} = 0.1V$ to $4.7V$ ; $-40^\circ C$ to $+85^\circ C$		3	10 15 <b>30</b>	mV
Cell Monitor Voltage Accuracy	$V_{ADC}$	Absolute cell measurement error (Cell measurement error compared with voltage at the cell) $V_{Cn} - V_{C(n-1)} = 2.4V$ to $4.2V$ ; $0^\circ C$ to $+60^\circ C$ $V_{Cn} - V_{C(n-1)} = 0.1V$ to $4.7V$ ; $0^\circ C$ to $+60^\circ C$ $V_{Cn} - V_{C(n-1)} = 0.1V$ to $4.7V$ ; $-40^\circ C$ to $+85^\circ C$	-15 -20 <b>-30</b>		15 20 <b>30</b>	mV
$V_{BATT}$ Voltage Accuracy	$V_{BATT}$	$V_{BATT} - [V_{BB}:V_{B0}]_{10} * 32 * 1.8 / 4095$ ; $0^\circ C$ to $+60^\circ C$ $-40^\circ C$ to $+85^\circ C$	-200 <b>-270</b>		200 <b>270</b>	mV
<b>CURRENT SENSE AMPLIFIER SPECIFICATIONS</b>						
Charge Current Threshold	VCCTH	VCS1-VCS2, CHING indicates charge current $V_{CS1} = 26.4V$		-100		$\mu V$
Discharge Current Threshold	VDCTH	VCS1-VCS2, DCHING indicates discharge current; $V_{CS1} = 26.4V$		100		$\mu V$
Current Sense Accuracy	VIA1	$V_{IA1} = ([ISNSB:ISNS0]_{10} * 1.8 / 4095) / 5$ ; CHING bit set Gain = 5 $V_{CS1} = 26.4V$ , $V_{CS2} - V_{CS1} = +100mV$	<b>97</b>	102	<b>107</b>	mV
	VIA2	$V_{IA2} = ([ISNSB:ISNS0]_{10} * 1.8 / 4095) / 5$ ; DCHING bit set Gain = 5 $V_{CS1} = 26.4V$ , $V_{CS2} - V_{CS1} = -100mV$	<b>-107</b>	-102	<b>-97</b>	mV
	VIA3	$V_{IA3} = ([ISNSB:ISNS0]_{10} * 1.8 / 4095) / 50$ ; CHING bit set Gain = 50 $V_{CS1} = 26.4V$ , $V_{CS2} - V_{CS1} = +10mV$	<b>8.0</b>	10.0	<b>12.0</b>	mV
	VIA4	$V_{IA4} = ([ISNSB:ISNS0]_{10} * 1.8 / 4095) / 50$ ; DCHING bit set Gain = 50 $V_{CS1} = 26.4V$ , $V_{CS2} - V_{CS1} = -10mV$	<b>-12.0</b>	-10.0	<b>-8.0</b>	mV
	VIA5	$V_{IA3} = ([ISNSB:ISNS0]_{10} * 1.8 / 4095) / 500$ ; CHING bit set Gain = 500 $V_{CS1} = 26.4V$ , $V_{CS2} - V_{CS1} = +1mV$ $0^\circ C$ to $+60^\circ C$ $-40^\circ C$ to $+85^\circ C$	0.5 <b>0.4</b>	1.0	1.5 <b>1.6</b>	mV
	VIA6	$V_{IA4} = ([ISNSB:ISNS0]_{10} * 1.8 / 4095) / 500$ ; DCHING bit set Gain = 500 $V_{CS1} = 26.4V$ , $V_{CS2} - V_{CS1} = -1mV$ $0^\circ C$ to $+60^\circ C$ $-40^\circ C$ to $+85^\circ C$	-1.5 <b>-1.6</b>	-1.0	-0.5 <b>-0.4</b>	mV

**Electrical Specifications**  $V_{DD} = 26.4V$ ,  $T_A = -40^{\circ}C$  to  $+85^{\circ}C$ , unless otherwise specified. **Boldface specification limits apply across operating temperature range,  $-40^{\circ}C$  to  $+85^{\circ}C$ .** (Continued)

PARAMETER	SYMBOL	TEST CONDITIONS	MIN (Note 7)	TYP	MAX (Note 7)	UNIT
<b>OVERCURRENT/SHORT-CIRCUIT PROTECTION SPECIFICATIONS</b>						
Discharge Overcurrent Detection Threshold	$V_{OCD}$	$V_{OCD} = 4mV$ [OCD2:0] = 0,0,0	<b>2.6</b>	4.0	<b>5.4</b>	mV
		$V_{OCD} = 8mV$ [OCD2:0] = 0,0,1	<b>6.4</b>	8.0	<b>9.6</b>	mV
		$V_{OCD} = 16mV$ [OCD2:0] = 0,1,0	<b>12.8</b>	16.0	<b>19.2</b>	mV
		$V_{OCD} = 24mV$ [OCD2:0] = 0,1,1	<b>20</b>	25	<b>30</b>	mV
		$V_{OCD} = 32mV$ [OCD2:0] = 1,0,0 (default)	<b>26.4</b>	33.0	<b>39.6</b>	mV
		$V_{OCD} = 48mV$ [OCD2:0] = 1,0,1	<b>42.5</b>	50.0	<b>57.5</b>	mV
		$V_{OCD} = 64mV$ [OCD2:0] = 1,1,0	<b>60.3</b>	67.0	<b>73.7</b>	mV
		$V_{OCD} = 96mV$ [OCD2:0] = 1,1,1	<b>90</b>	100	<b>110</b>	mV
Discharge Overcurrent Detection Time	$t_{OCDT}$	[OCDTA:OCDDT0] = 0A0H (160ms) (default) Range: 0ms to 1023ms 1ms/step 0s to 1023s; 1s/step		160		ms
Short-Circuit Detection Threshold	$V_{SCD}$	$V_{SCD} = 16mV$ [SCD2:0] = 0,0,0	<b>10.4</b>	16.0	<b>21.6</b>	mV
		$V_{SCD} = 24mV$ [SCD2:0] = 0,0,1	<b>18</b>	24	<b>30</b>	mV
		$V_{SCD} = 32mV$ [SCD2:0] = 0,1,0	<b>26</b>	33	<b>40</b>	mV
		$V_{SCD} = 48mV$ [SCD2:0] = 0,1,1	<b>42</b>	49	<b>56</b>	mV
		$V_{SCD} = 64mV$ [SCD2:0] = 1,0,0	<b>60</b>	67	<b>74</b>	mV
		$V_{SCD} = 96mV$ [SCD2:0] = 1,0,1 (default)	<b>90</b>	100	<b>110</b>	mV
		$V_{SCD} = 128mV$ [SCD2:0] = 1,1,0	<b>127</b>	134	<b>141</b>	mV
		$V_{SCD} = 256mV$ [SCD2:0] = 1,1,1	<b>249</b>	262	<b>275</b>	mV
Short-Circuit Current Detection Time	$t_{SCT}$	[SCTA:SCT0] = 0C8H (200 $\mu$ s) (default) Range: 0 $\mu$ s to 1023 $\mu$ s; 1 $\mu$ s/step 0ms to 1023ms 1ms/step		200		$\mu$ s
Charge Overcurrent Detection Threshold	$V_{OCC}$	$V_{OCC} = 1mV$ [OCC2:0] = 0,0,0	<b>0.2</b>	1.0	<b>2.1</b>	mV
		$V_{OCC} = 2mV$ [OCC2:0] = 0,0,1	<b>0.7</b>	2.0	<b>3.3</b>	mV
		$V_{OCC} = 4mV$ [OCC2:0] = 0,1,0	<b>2.8</b>	4.0	<b>5.2</b>	mV
		$V_{OCC} = 6mV$ [OCC2:0] = 0,1,1	<b>4.5</b>	6.0	<b>7.5</b>	mV
		$V_{OCC} = 8mV$ [OCC2:0] = 1,0,0 (default)	<b>6.6</b>	8.0	<b>9.8</b>	mV
		$V_{OCC} = 12mV$ [OCC2:0] = 1,0,1	<b>9.6</b>	12.0	<b>14.4</b>	mV
		$V_{OCC} = 16mV$ [OCC2:0] = 1,1,0	<b>14.5</b>	17.0	<b>19.6</b>	mV
		$V_{OCC} = 24mV$ [OCC2:0] = 1,1,1	<b>22.5</b>	25.0	<b>27.5</b>	mV
Overcurrent Charge Detection Time	$t_{OCCT}$	[OCCTA:OCCT0] = 0A0H (160ms) (default) Range: 0ms to 1023ms 1ms/step 0s to 1023s; 1s per step		160		ms
Charge Monitor Input Threshold (Falling Edge)	$V_{CHMON}$	$\mu$ CCMON bit = "1"; CMON_EN bit = "1"	<b>8.2</b>	8.9	<b>9.8</b>	V
Load Monitor Input Threshold (Rising Edge)	$V_{LDMON}$	$\mu$ CLMON bit = "1"; LMON_EN bit = "1"	<b>0.45</b>	0.6	<b>0.75</b>	V
Load Monitor Output Current	$I_{LDMON}$	$\mu$ CLMON bit = "1"; LMON_EN bit = "1"		62		$\mu$ A

**Electrical Specifications**  $V_{DD} = 26.4V$ ,  $T_A = -40^{\circ}C$  to  $+85^{\circ}C$ , unless otherwise specified. **Boldface specification limits apply across operating temperature range,  $-40^{\circ}C$  to  $+85^{\circ}C$ .** (Continued)

PARAMETER	SYMBOL	TEST CONDITIONS	MIN (Note 7)	TYP	MAX (Note 7)	UNIT
<b>VOLTAGE PROTECTION SPECIFICATIONS</b>						
Overvoltage Lockout Threshold (Rising Edge - Any Cell) [VCn-VC(n-1)]	$V_{OVLO}$	[OVLOB:OVLO0] = 0E80H (4.35V) (default) Range: 12-bit value (0V to 4.8V)		4.35		V
Overvoltage Lockout Recovery Threshold - All Cells	$V_{OVLOR}$	Falling edge		$V_{OVR}$		V
Undervoltage Lockout Threshold (Falling Edge - Any Cell) [VCn-VC(n-1)]	$V_{UVLO}$	[UVLOB:UVLO0] = 0600H (1.8V) (default) Range: 12-bit value (0V to 4.8V)		1.8		V
Undervoltage Lockout Recovery Threshold - All Cells	$V_{UVLOR}$	Rising edge		$V_{UVR}$		V
Overvoltage Lockout Detection Time	$t_{OVLO}$	Normal operating mode 5 consecutive samples over the limit (minimum = 160ms, maximum = 192ms)		176		ms
Undervoltage Lockout Detection Time	$t_{UVLO}$	Normal operating mode 5 consecutive samples under the limit (minimum = 160ms, maximum = 192ms)		176		ms
Overvoltage Threshold (Rising Edge - Any Cell) [VCn-VC(n-1)]	$V_{OV}$	[OVLB:OVLO] = 0E2AH (4.25V) (default) Range: 12-bit value (0V to 4.8V)		4.25		V
Overvoltage Recovery Voltage (Falling Edge - All Cells) [VCn-VC(n-1)]	$V_{OVR}$	[OVRB:OVR0] = 0DD5H (4.15V) (default) Range: 12-bit value (0V to 4.8V)		4.15		V
Overvoltage Detection/Release Time	$t_{OVT}$	[OVTA:OVT0] = 201H (1s) (default) Range: 0ms to 1023ms; 1ms/step 0s to 1023s; 1s/step		1		s
Undervoltage Threshold (Falling Edge - Any Cell) [VCn-VC(n-1)]	$V_{UV}$	[UVLB:UVLO] = 0900H (2.7V) (default) Range: 12-bit value (0V to 4.8V)		2.7		V
Undervoltage Recovery Voltage (Rising Edge - All Cells) [VCn-VC(n-1)]	$V_{UVR}$	[UVRB:UVR0] = 0A00H (3.0V) (default) Range: 12-bit value (0V to 4.8V)		3.0		V
Undervoltage Detection Time	$t_{UVT}$	[UVTA:UVT0] = 201H (1s) (default) Range: 0ms to 1023ms; 1ms/step 0s to 1023s; 1s/step		1		s
Undervoltage Release Time	$t_{UVTR}$	[UVTA:UVT0] = 201H (1s) + 2s (default) Range: (0ms to 1023ms) + 2s; 1ms/step (0s to 1023s) + 2s; 1s/step		3		s
Sleep Voltage Threshold (Falling Edge - Any Cell) [VCn-VC(n-1)]	$V_{SLL}$	[SLLB:SLL0] = 06AAH (2.0V) (default) Range: 12-bit value (0V to 4.8V)		2.0		V
Sleep Detection Time	$t_{SLT}$	[SLTA:SLT0] = 201H (1s) (default) Range: 0ms to 1023ms; 1ms/step 0s to 1023s; 1s/step		1		s
Low Voltage Charge Threshold (Falling Edge - Any Cell) [VCn-VC(n-1)]	$V_{LVCH}$	[LVCHB:LVCH0] = 07AAH (2.3V) (default) Range: 12-bit value (0V to 4.8V) Pre-charge if any cell is below this voltage		2.3		V
Low Voltage Charge Threshold Hysteresis	$V_{LVCHH}$			117		mV

**Electrical Specifications**  $V_{DD} = 26.4V$ ,  $T_A = -40^\circ C$  to  $+85^\circ C$ , unless otherwise specified. **Boldface specification limits apply across operating temperature range,  $-40^\circ C$  to  $+85^\circ C$ .** (Continued)

PARAMETER	SYMBOL	TEST CONDITIONS	MIN (Note 7)	TYP	MAX (Note 7)	UNIT
End-of-Charge Threshold (Rising Edge - Any Cell) [VCn-VC(n-1)]	$V_{EOC}$	[EOCSB:EOCS0] = 0E00H (4.2V) (default) Range: 12-bit value (0V to 4.8V)		4.2		V
End-of-Charge Threshold Hysteresis	$V_{EOCH}$			117		mV
Sleep Mode Timer	$t_{SMT}$	[MOD7:MOD0] = 0DH (off) (default) Range: 0s to 255 minutes		90		min
Watchdog Timer	$t_{WDT}$	[WDT4:WDT0] = 1FH (31s) (default) Range: 0s to 31s		31		s
<b>TEMPERATURE PROTECTION SPECIFICATIONS</b>						
Internal Temperature Shutdown Threshold	$T_{ITSD}$	[IOTSB:IOTS0] = 02D8H		115		$^\circ C$
Internal Temperature Recovery	$T_{ITRCV}$	[IOTRB:IOTR0] = 027DH		95		$^\circ C$
External Temperature Output Voltage	$V_{TEMPO}$	Voltage output at TEMPO pin (during temperature scan); $I_{TEMPO} = 1mA$	<b>2.30</b>	2.45	<b>2.60</b>	V
External Temperature Limit Threshold (Hot) - xT1 or xT2 Charge, Discharge, Cell Balance (see <a href="#">Figure 3</a> )	$T_{XTH}$	xTn Hot threshold. Voltage at $V_{TEMPi}$ . xT1 or xT2 = 04B6H TGain = 0 ~+55 $^\circ C$ ; thermistor = 3.535k Detected by COT, DOT, CBOT bits = 1		0.265		V
External Temperature Recovery Threshold (Hot) - xT1 or xT2 Charge, Discharge, Cell Balance (see <a href="#">Figure 3</a> )	$T_{XTHR}$	xTn Hot recovery voltage at $V_{TEMPi}$ . xT1 or xT2 = 053EH TGain = 0 (~+50 $^\circ C$ ; thermistor = 4.161k) Detected by COT, DOT, CBOT bits = 0		0.295		V
External Temperature Limit Threshold (Cold) - xT1 or xT2 Charge, Discharge, Cell Balance (see <a href="#">Figure 3</a> )	$T_{XTC}$	xTn Cold threshold. Voltage at $V_{TEMPi}$ . xT1 or xT2 = 0BF2H TGain = 0 (~ -10 $^\circ C$ ; thermistor = 42.5k) Detected by CUT, DUT, CBUT bits		0.672		V
External Temperature Recovery Threshold (Cold) - xT1 or xT2 Charge, Discharge, Cell Balance (see <a href="#">Figure 3</a> )	$T_{XTCH}$	xTn Cold recovery voltage at $V_{TEMPi}$ . xT1 or xT2 = 0A93H TGain = 0 (~5 $^\circ C$ ; thermistor = 22.02k) Detected by CUT, DUT, CBUT bits		0.595		V
<b>CELL BALANCE SPECIFICATIONS</b>						
Cell Balance FET Gate Drive Current		VC1 to VC5 (current out of pin)	<b>15</b>	25	<b>35</b>	$\mu A$
		VC6 to VC8 (current into pin)	<b>15</b>	25	<b>35</b>	$\mu A$
Cell Balance Maximum Voltage Threshold (Rising Edge - Any cell) [VCMAX]	$V_{CBMX}$	[CBVUB:CBVU0] = 0E00H (4.2V) (default) Range: 12-bit value (0V to 4.8V)		4.2		V
Cell Balance Maximum Threshold Hysteresis	$V_{CBMXH}$			117		mV
Cell Balance Minimum Voltage Threshold (Falling Edge - Any cell) [VCMIN]	$V_{CBMN}$	[CBVLB:CBVLO] = 0A00H (3.0V) (default) Range: 12-bit value (0V to 4.8V)		3.0		V
Cell Balance Minimum Threshold Hysteresis	$V_{CBMNH}$			117		mV

**Electrical Specifications**  $V_{DD} = 26.4V$ ,  $T_A = -40^{\circ}C$  to  $+85^{\circ}C$ , unless otherwise specified. **Boldface specification limits apply across operating temperature range,  $-40^{\circ}C$  to  $+85^{\circ}C$ .** (Continued)

PARAMETER	SYMBOL	TEST CONDITIONS	MIN (Note 7)	TYP	MAX (Note 7)	UNIT
Cell Balance Maximum Voltage Delta Threshold (Rising Edge - Any Cell) [VCn-VC(n-1)]	V <sub>CBDU</sub>	[CBDUB:CBDO] = 06AAH (2.0V) (default) Range: 12-bit value (0V to 4.8V)		2.0		V
Cell Balance Maximum Voltage Delta Threshold Hysteresis	V <sub>CBDUH</sub>			117		mV
<b>WAKE-UP SPECIFICATIONS</b>						
Device CHMON Pin Voltage Threshold (Wake on Charge) (Rising Edge)	V <sub>WKUP1</sub>	CHMON pin rising edge Device wakes up and sets Sleep flag LOW	<b>7.0</b>	8.0	<b>9.0</b>	V
Device LDMON Pin Voltage Threshold (Wake on Load) (Falling Edge)	V <sub>WKUP2</sub>	LDMON pin falling edge Device wakes up and sets Sleep flag LOW	<b>0.15</b>	0.40	<b>0.70</b>	V
<b>OPEN-WIRE SPECIFICATIONS</b>						
Open-Wire Current	I <sub>OW</sub>			1.0		mA
Open-Wire Detection Threshold	V <sub>OW1</sub>	VCn-VC(n-1); VCn is open. (n = 2, 3, 4, 5, 6, 7, 8). Open-wire detection active on the VCn input.		-0.3		V
	V <sub>OW2</sub>	VC1-VCO; VC1 is open. Open-wire detection active on the VC1 input.		0.4		V
	V <sub>OW3</sub>	VCO-VSS; VCO is open. Open-wire detection active on the VCO input.		1.25		V
<b>FET CONTROL SPECIFICATIONS</b>						
DFET Gate Voltage	V <sub>DFET1</sub>	(ON) 100 $\mu$ A load; V <sub>DD</sub> = 36V	<b>47</b>	52	<b>57</b>	V
	V <sub>DFET2</sub>	(ON) 100 $\mu$ A load; V <sub>DD</sub> = 6V	<b>8</b>	9	<b>10</b>	V
	V <sub>DFET3</sub>	(OFF)		0		V
CFET Gate Voltage (ON)	V <sub>CFET1</sub>	(ON) 100 $\mu$ A load; V <sub>DD</sub> = 36V	<b>47</b>	52	<b>57</b>	V
	V <sub>CFET2</sub>	(ON) 100 $\mu$ A load; V <sub>DD</sub> = 6V	<b>8</b>	9	<b>10</b>	V
	V <sub>CFET3</sub>	(OFF)		V <sub>DD</sub>		V
PCFET Gate Voltage (ON)	V <sub>PFET1</sub>	(ON) 100 $\mu$ A load; V <sub>DD</sub> = 36V	<b>47</b>	52	<b>57</b>	V
	V <sub>PFET2</sub>	(ON) 100 $\mu$ A load; V <sub>DD</sub> = 6V	<b>8</b>	9	<b>10</b>	V
	V <sub>PFET3</sub>	(OFF)		V <sub>DD</sub>		V
FET Turn-Off Current (DFET)	I <sub>DF(OFF)</sub>		<b>14</b>	15	<b>16</b>	mA
FET Turn-Off Current (CFET)	I <sub>CF(OFF)</sub>		<b>9</b>	13	<b>17</b>	mA
FET Turn-Off Current (PCFET)	I <sub>PF(OFF)</sub>		<b>9</b>	13	<b>17</b>	mA
FETSOFF Rising Edge Threshold	V <sub>FO(IH)</sub>	FETSOFF rising edge threshold. Turn off FETs		1.8		V
FETSOFF Falling Edge Threshold	V <sub>FO(IL)</sub>	FETSOFF falling edge threshold. Turn on FETs		1.2		V
<b>SERIAL INTERFACE CHARACTERISTICS (Note 8)</b>						
Input Buffer Low Voltage (SCL, SDA)	V <sub>IL</sub>	Voltage relative to V <sub>SS</sub> of the device	<b>-0.3</b>		<b>V<sub>RGO</sub> x 0.3</b>	V
Input Buffer High Voltage (SCL, SDAI, SDAO)	V <sub>IH</sub>	Voltage relative to V <sub>SS</sub> of the device	<b>V<sub>RGO</sub> x 0.7</b>		<b>V<sub>RGO</sub> + 0.1</b>	V
Output Buffer Low Voltage (SDA)	V <sub>OL</sub>	I <sub>OL</sub> = 1mA			<b>0.4</b>	V
SDA and SCL Input Buffer Hysteresis	I <sup>2</sup> CHYST	Sleep bit = 0	<b>0.05 x V<sub>RGO</sub></b>			V
SCL Clock Frequency	f <sub>SCL</sub>				<b>400</b>	kHz

**Electrical Specifications**  $V_{DD} = 26.4V$ ,  $T_A = -40^{\circ}C$  to  $+85^{\circ}C$ , unless otherwise specified. **Boldface specification limits apply across operating temperature range,  $-40^{\circ}C$  to  $+85^{\circ}C$ . (Continued)**

PARAMETER	SYMBOL	TEST CONDITIONS	MIN (Note 7)	TYP	MAX (Note 7)	UNIT
Pulse Width Suppression Time at SDA and SCL Inputs	$t_{IN}$	Any pulse narrower than the maximum spec is suppressed.			<b>50</b>	ns
SCL Falling Edge to SDA Output Data Valid	$t_{AA}$	From SCL falling crossing $V_{IH}$ (minimum), until SDA exits the $V_{IL}$ (maximum) to $V_{IH}$ (minimum) window			<b>0.9</b>	$\mu s$
Time the Bus Must Be Free Before Start of New Transmission	$t_{BUF}$	SDA crossing $V_{IH}$ (minimum) during a STOP condition to SDA crossing $V_{IH}$ (minimum) during the following START condition	<b>1.3</b>			$\mu s$
Clock Low Time	$t_{LOW}$	Measured at the $V_{IL}$ (maximum) crossing	<b>1.3</b>			$\mu s$
Clock High Time	$t_{HIGH}$	Measured at the $V_{IH}$ (minimum) crossing	<b>0.6</b>			$\mu s$
Start Condition Set-Up Time	$t_{SU:STA}$	SCL rising edge to SDA falling edge, both crossing the $V_{IH}$ (minimum) level	<b>0.6</b>			$\mu s$
Start Condition Hold Time	$t_{HD:STA}$	From SDA falling edge crossing $V_{IL}$ (maximum) to SCL falling edge crossing $V_{IH}$ (minimum)	<b>0.6</b>			$\mu s$
Input Data Set-Up Time	$t_{SU:DAT}$	From SDA exiting the $V_{IL}$ (maximum) to $V_{IH}$ (minimum) window to SCL rising edge crossing $V_{IL}$ (minimum)	<b>100</b>			ns
Input Data Hold Time	$t_{HD:DAT}$	From SCL falling edge crossing $V_{IH}$ (minimum) to SDA entering the $V_{IL}$ (maximum) to $V_{IH}$ (minimum) window	<b>0</b>		<b>0.9</b>	$\mu s$
Stop Condition Set-Up Time	$t_{SU:STO}$	From SCL rising edge crossing $V_{IH}$ (minimum) to SDA rising edge crossing $V_{IL}$ (maximum)	<b>0.6</b>			$\mu s$
Stop Condition Hold Time	$t_{HD:STO}$	From SDA rising edge to SCL falling edge. Both crossing $V_{IH}$ (minimum)	<b>0.6</b>			$\mu s$
Data Output Hold Time	$t_{DH}$	From SCL falling edge crossing $V_{IL}$ (maximum) until SDA enters the $V_{IL}$ (maximum) to $V_{IH}$ (minimum) window	<b>0</b>			ns
SDA and SCL Rise Time	$t_R$	From $V_{IL}$ (maximum) to $V_{IH}$ (minimum)			<b>300</b>	ns
SDA and SCL Fall Time	$t_F$	From $V_{IH}$ (minimum) to $V_{IL}$ (maximum)			<b>300</b>	ns
SDA and SCL Bus Pull-Up Resistor Off-Chip	$R_{OUT}$	Maximum is determined by $t_R$ and $t_F$ For $C_B = 400pF$ , maximum is $2k\Omega \sim 2.5k\Omega$ For $C_B = 40pF$ , maximum is $15k\Omega \sim 20k\Omega$	<b>1</b>			$k\Omega$
Input Leakage (SCL, SDA)	$I_{LI}$		<b>-10</b>		<b>10</b>	$\mu A$
EEPROM Write Cycle Time	$t_{WR}$	$+25^{\circ}C$			<b>30</b>	ms

## NOTES:

- Parameters with MIN and/or MAX limits are 100% tested at  $+25^{\circ}C$ , unless otherwise specified. Device MIN and/or MAX values are based on temperature limits established by characterization and are not production tested.
- Compliance to datasheet limits is assured by one or more methods: production test, characterization and/or design.

## Symbol Table

WAVEFORM	INPUTS	OUTPUTS	WAVEFORM	INPUTS	OUTPUTS
	MUST BE STEADY	WILL BE STEADY		DON'T CARE: CHANGES ALLOWED	CHANGING: STATE NOT KNOWN
	MAY CHANGE FROM LOW TO HIGH	WILL CHANGE FROM LOW TO HIGH		N/A	CENTER LINE IS HIGH IMPEDANCE
	MAY CHANGE FROM HIGH TO LOW	WILL CHANGE FROM HIGH TO LOW			

## Timing Diagrams

### External Temperature Configuration

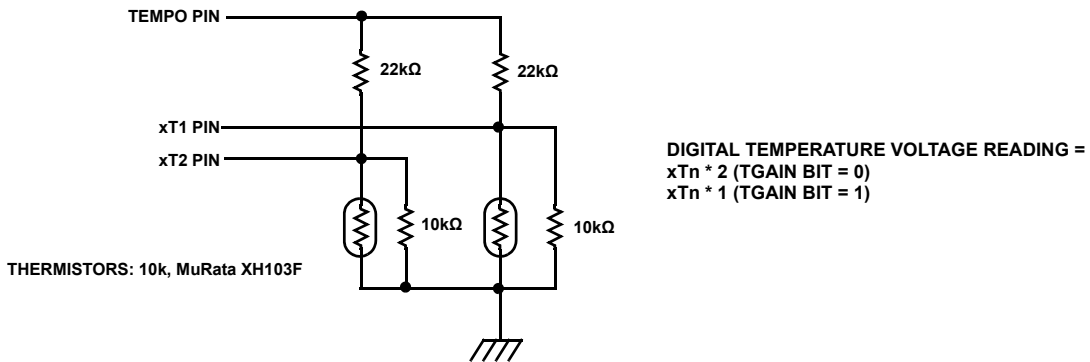

FIGURE 3. EXTERNAL TEMPERATURE CONFIGURATION

### Wake-Up Timing

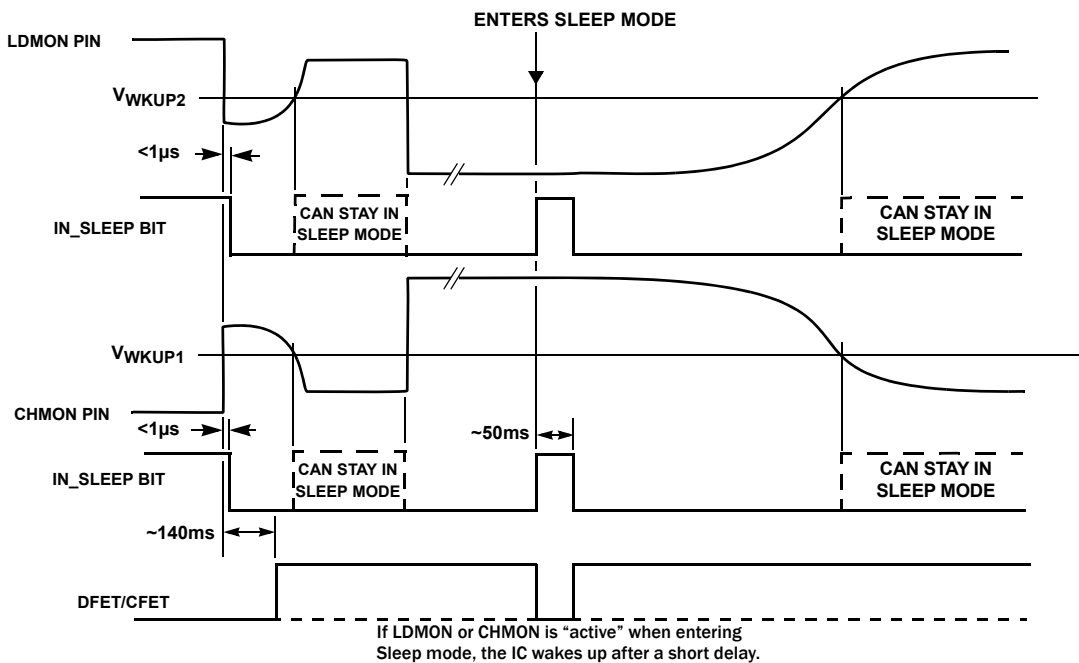

FIGURE 4. WAKE-UP TIMING (FROM SLEEP)

## Power-Up Timing

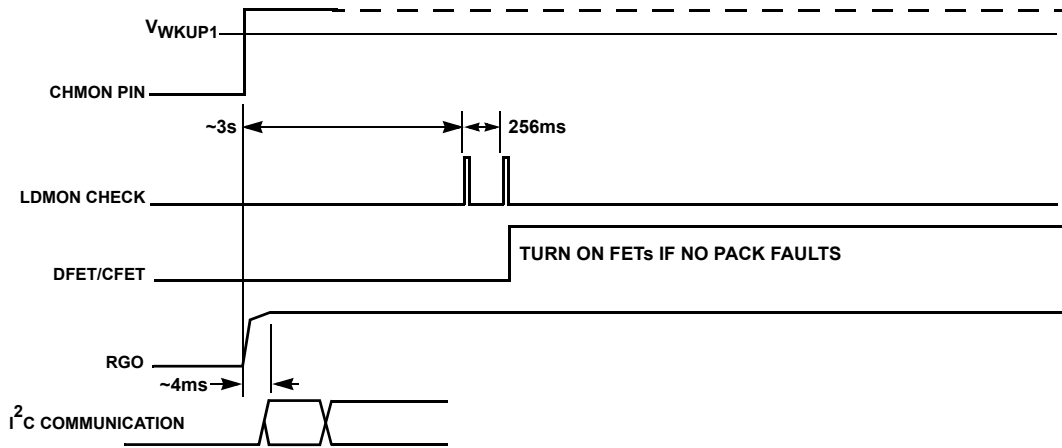

FIGURE 5. POWER-UP TIMING (FROM POWER UP/SHUTDOWN)

## Change in FET Control

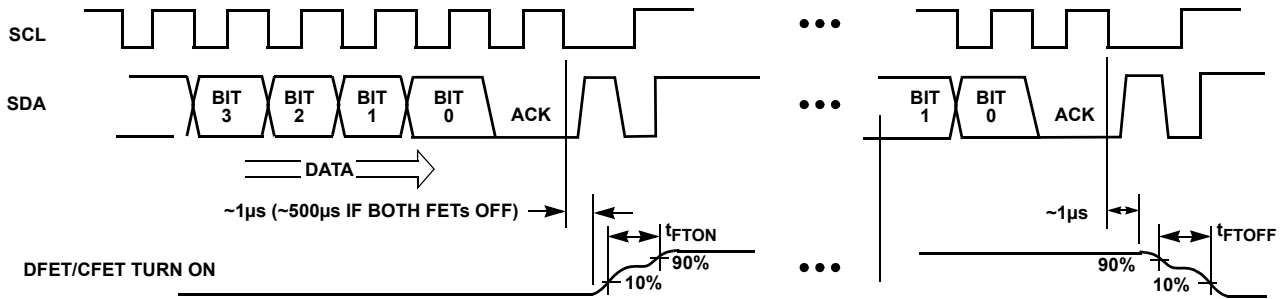

FIGURE 6.  $I^2C$  FET CONTROL TIMING

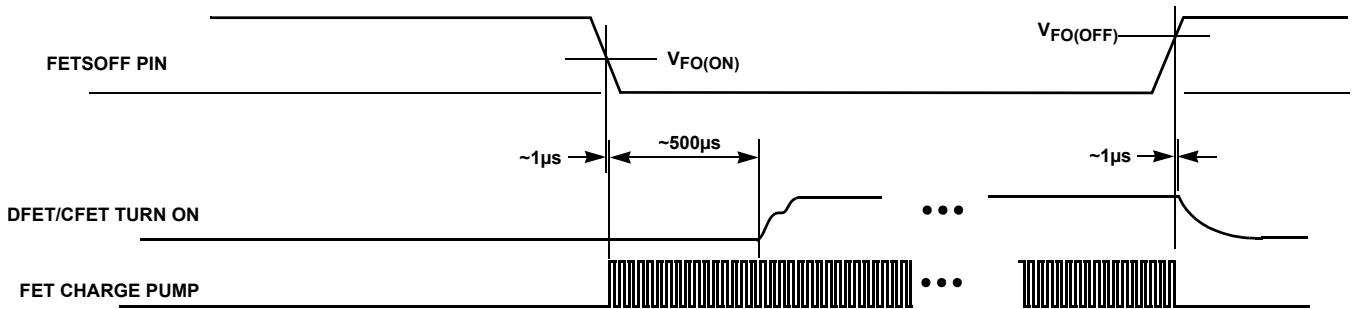

FIGURE 7. FETSOFF FET CONTROL TIMING

## Automatic Temperature Scan

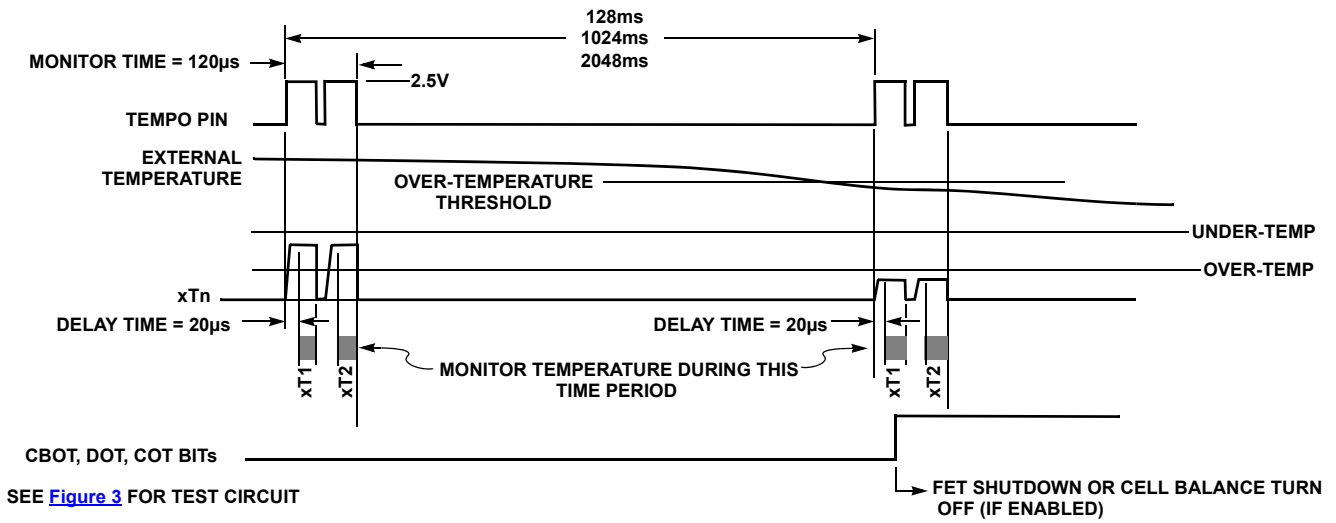

FIGURE 8. AUTOMATIC TEMPERATURE SCAN

## Serial Interface Timing Diagrams

### BUS TIMING

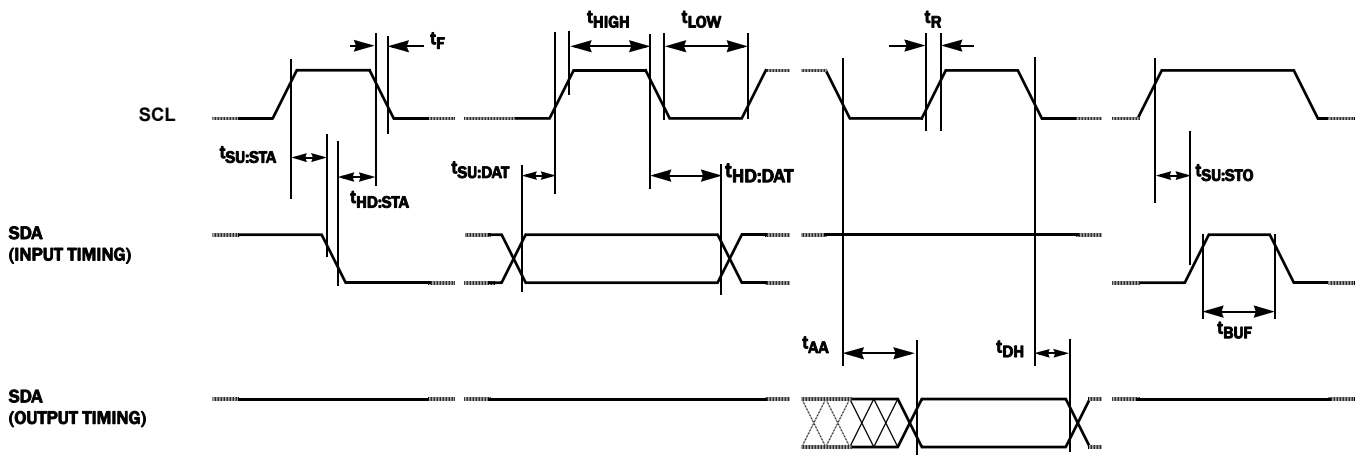

FIGURE 9. SERIAL INTERFACE BUS TIMING

## Discharge Overcurrent/Short-Circuit Monitor

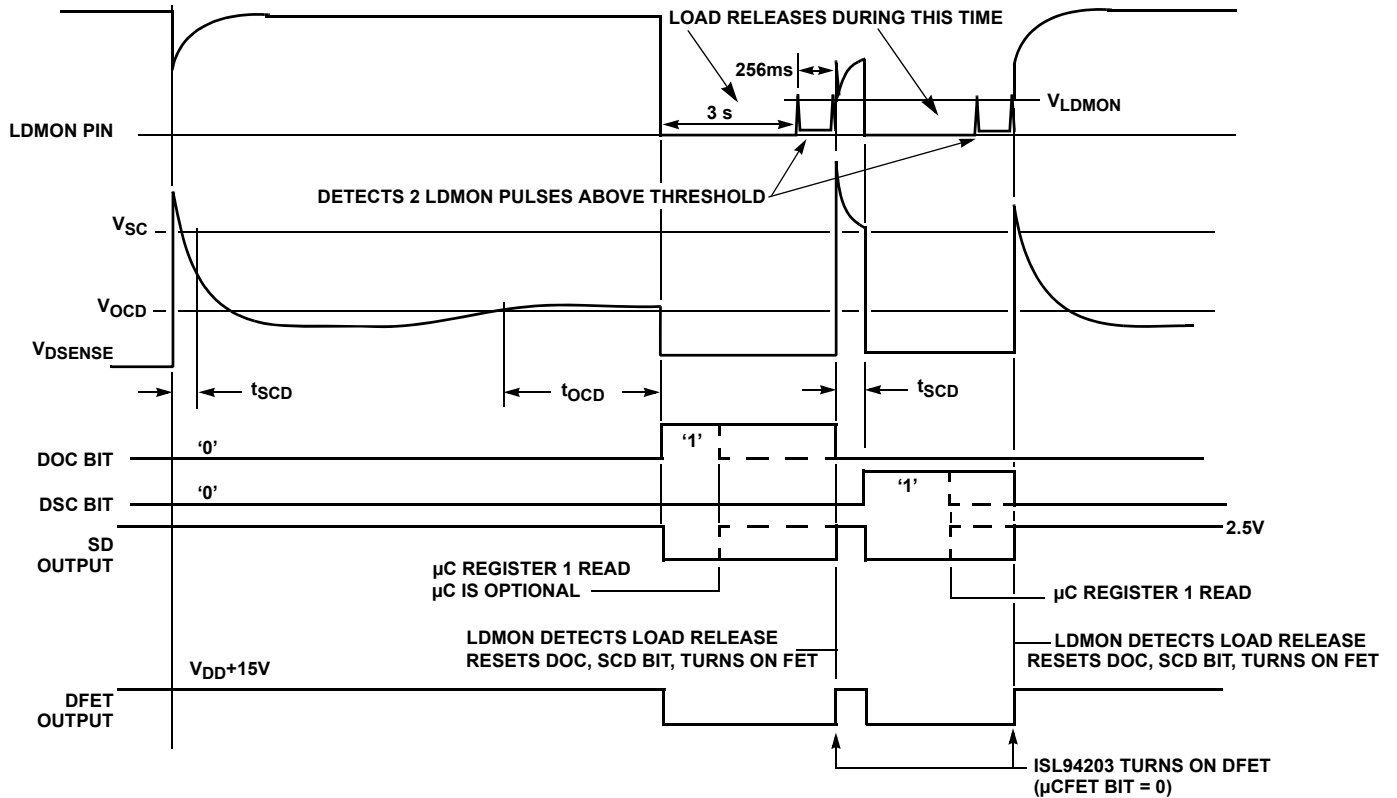

FIGURE 10. DISCHARGE/SHORT-CIRCUIT MONITOR

## Charge Overcurrent Monitor

(Assumes NO\_OCCR bit is '0')

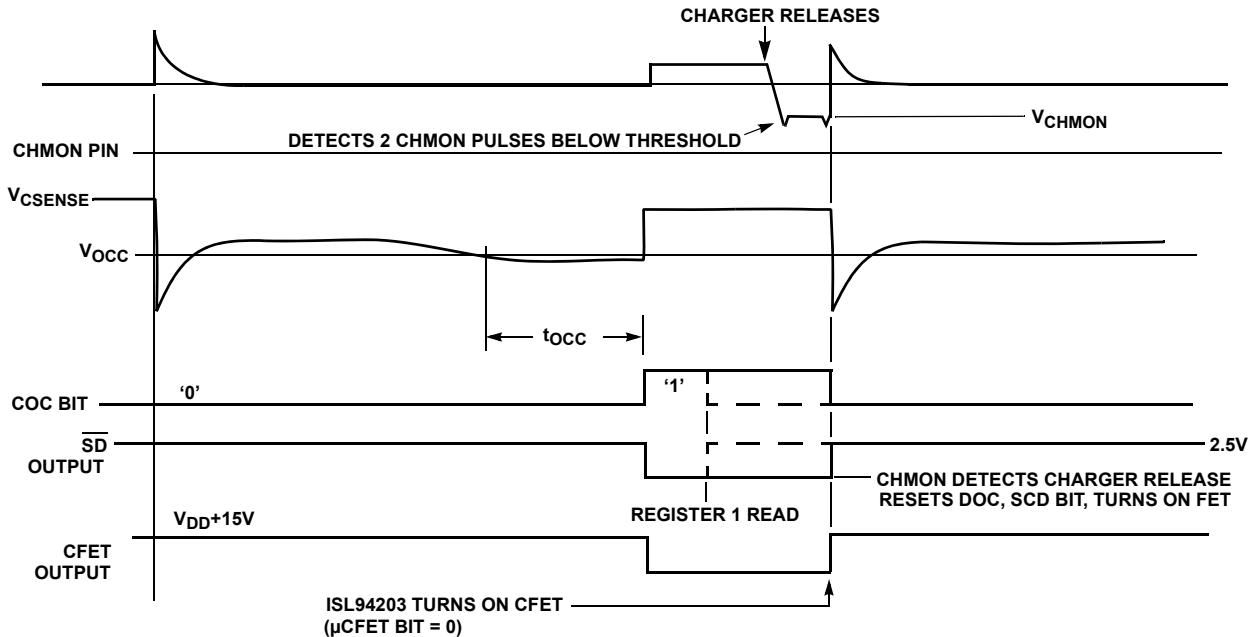

FIGURE 11. CHARGE OVERCURRENT MONITOR

## Functional Description

This IC is intended to be a stand-alone battery pack monitor, so it provides monitor and protection functions without using an external microcontroller.

The part locates the power control FETs on the high side with a built-in charge pump for driving N-channel FETs. The current sense resistor is also on the high side.

Power is minimized in all areas, with parts of the circuit powered down a majority of the time, to extend battery life. At the same time, the RGO output stays on so that any connected microcontroller can remain on most of the time.

The ISL94203 includes:

- Input level shifter to enable monitoring of battery stack voltages
- 14-bit ADC converter, with voltage readings trimmed and saved as 12-bit results
- 1.8V voltage reference (0.8% accurate)
- 2.5V regulator, with the voltage maintained during sleep
- Automatic scan of the cell voltages; overvoltage, undervoltage and sleep voltage monitoring
- Selectable overcurrent detection settings
  - 8 Discharge overcurrent thresholds
  - 8 Charge overcurrent thresholds
  - 8 Short-circuit thresholds
  - 12-bit programmable discharge overcurrent delay time
  - 12-bit programmable charge overcurrent delay time
  - 12-bit programmable short-circuit delay time
- Current sense monitor with gain that provides the ability to read the current sense voltage
- Second external temperature sensor for use in monitoring the pack or power FET temperatures
- EEPROM for storing operating parameters and a user area for general purpose pack information

## Battery Connections

### Power Path

[Figure 12](#) shows the main power path connections for a single charge/discharge path. [Figure 13](#) shows the connection for separate charge/discharge paths.

These figures show Schottky diodes on the VDD pin. These are to maintain the voltage on the VDD pin during high current conditions or when the Charge FET is OFF. These are not needed if V<sub>DD</sub> can be maintained within 0.5V of V<sub>BATT</sub>.

The CHMON pin connects to the pack pin that receives the charge and the LDMON pin connects to the pack pin that drives the load. For the single path application, these pins can tie together.

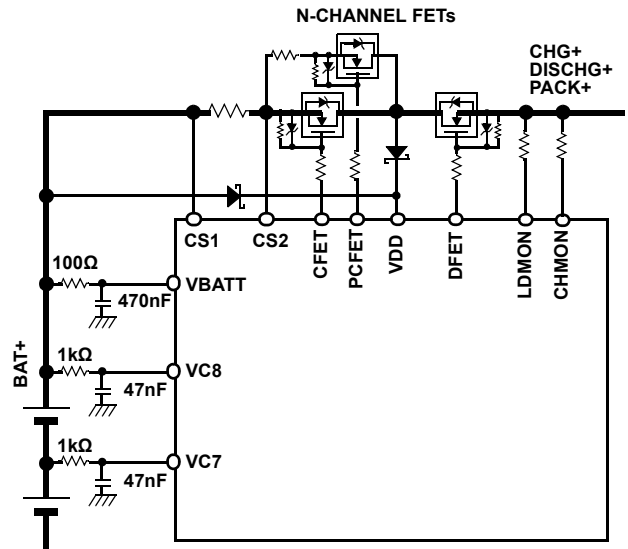

FIGURE 12. SINGLE PATH FET DRIVE/POWER SUPPLY DETAIL

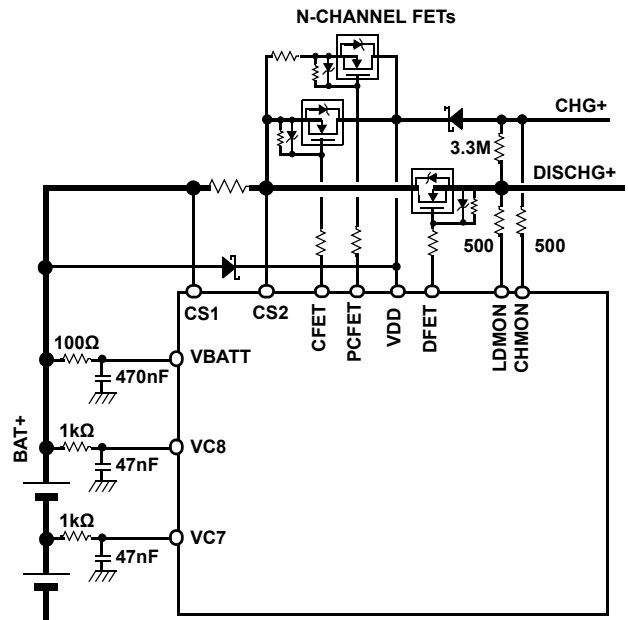

FIGURE 13. DUAL PATH FET DRIVE/POWER SUPPLY DETAIL

### Pack Configuration

A register in EEPROM (CELLS) identifies the number of cells that are supposed to be present, so the ISL94203 only scans these cells. This register is also used for the cell balance operation. The register contents are a 1:1 representation of the cells connected to the pack. For example, in a 6 cell pack, the value in CELLS is '11100111' (CFH), which indicates that cells 1, 2, 3, 6, 7 and 8 are connected. Also see [Figure 14 on page 21](#).

### Battery Cell Connections

Suggested connections for pack configurations varying from 3 cells to 8 cells are shown in [Figure 14](#).

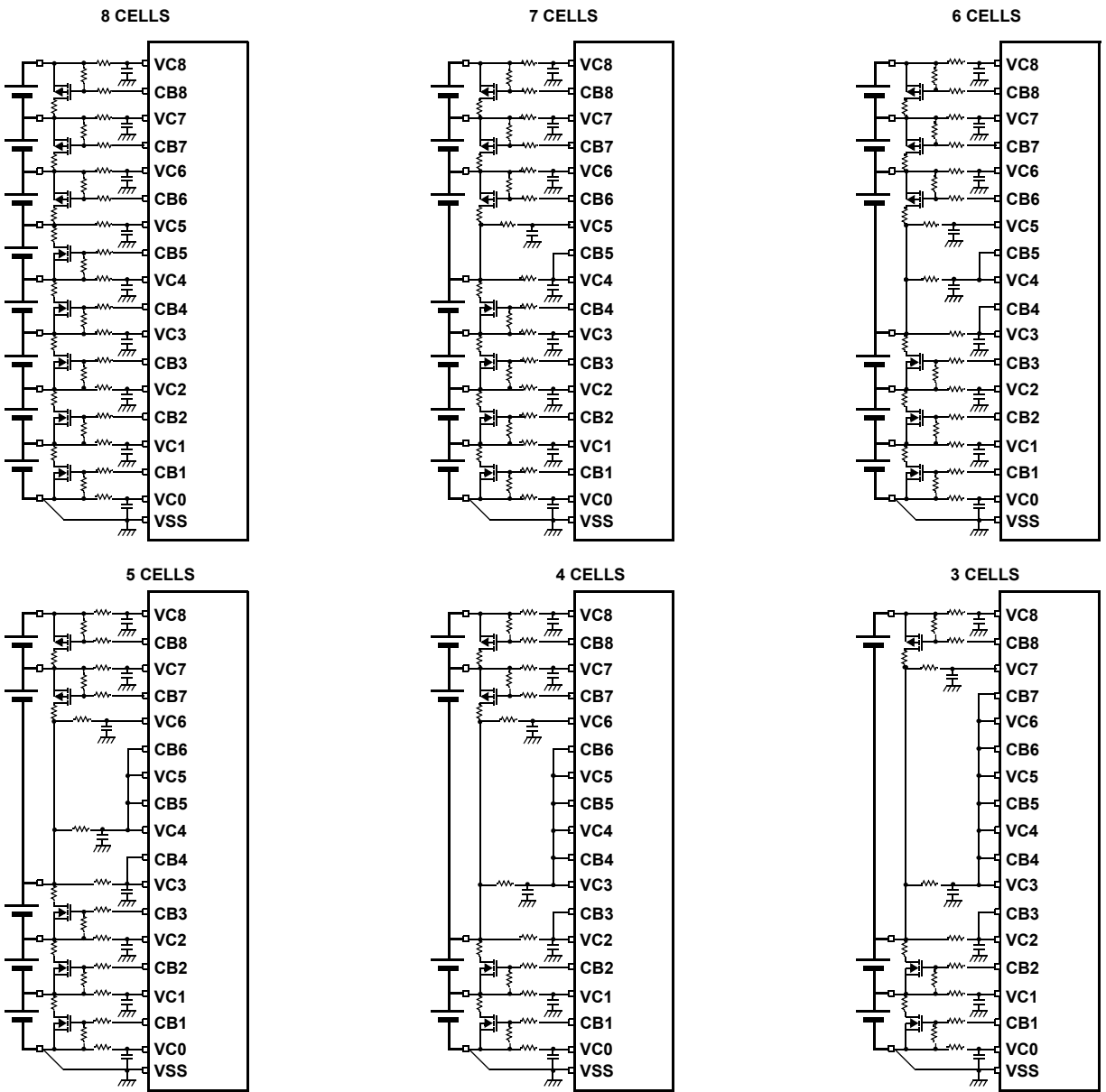

NOTE: MULTIPLE CELLS CAN BE CONNECTED IN PARALLEL

FIGURE 14. BATTERY CONNECTION OPTIONS

## Operating Modes

### Power-Up Operation

When the ISL94203 first connects to the battery pack, it is unknown which pins connect first or in what order. When the VDD and VSS pins connect, the device enters the power-down state. It remains in this state until a charger is connected. The device will also power up if the CHMON pin is connected to the VDD pin through an outside resistor to simplify the PCB manufacture. It is possible that the pack powers up automatically when the battery stack is connected due to momentary conduction through the power FET G-S and G-D capacitors.

Once the charger connects (or CHMON connects), the internal power supply turns on. This powers up all internal supplies and

starts the state machine. If some cells are not connected, the state machine recognizes this, either through the open-wire test (see [“Typical Operating Conditions” on page 24](#)) or because the monitored cell voltage reads zero, when the “CELLS” register indicates that there should be a voltage at that pin. If the cell voltages do not read correctly, then the ISL94203 remains in the POR loop until conditions are valid for power-up (It is for this reason that the factory default for the device is 3 Cells. When manufacturing the application board, cells 1, 2 and 8 must be connected to power up. If other cells are connected it is OK, but for the other cells to be monitored, the CELLS register needs to be changed).

If the inputs all read good during this sequence, then the state machine enters the normal monitor state. In the normal state, if all cell voltages read good and there are no overcurrent or

temperature issues and there is no load, the FETs turn on. To determine if there is a load, the device does a load check. This operation waits for about three seconds and then must see no load for two successive load monitor cycles (256ms apart).

During the POR operation, the RAM registers are all reset to default conditions from values saved in the EEPROM.

When the cell voltages drop, the ISL94203 remains on if the VDD voltage remains above 1V and the VRGO voltage is above 2.25V. This is to maintain operation of the device in the event of a short drop in cell voltage due to a pack short-circuit condition. In the event of a longer battery stack voltage drop, then the device will return to a power-down condition if VDD drops below a POR threshold of about 3.5V when VRGO is below 2.25V (see [Figures 15](#) and [16](#)).

- DO A VOLTAGE SCAN.
- ONLY LOOK AT CELLS THAT ARE SPECIFIED IN THE "CELL" REG.
- IF ALL CELL VOLTAGES AND TEMPS ARE OK, DO A LOAD TEST.
- IF THERE ARE ANY ERRORS, KEEP SCANNING VOLTAGES, TEMPERATURES AND LOAD AT NORMAL SCAN RATES.

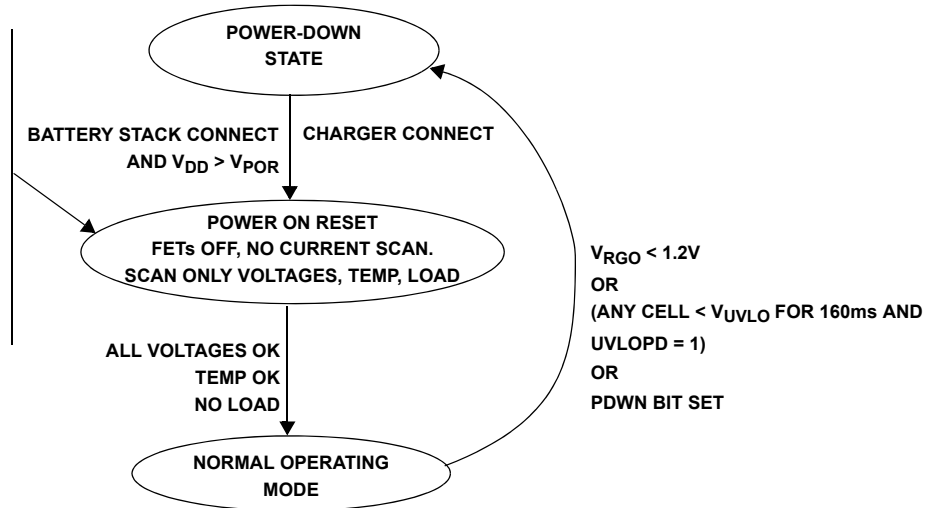

FIGURE 15. POWER-ON RESET STATE MACHINE

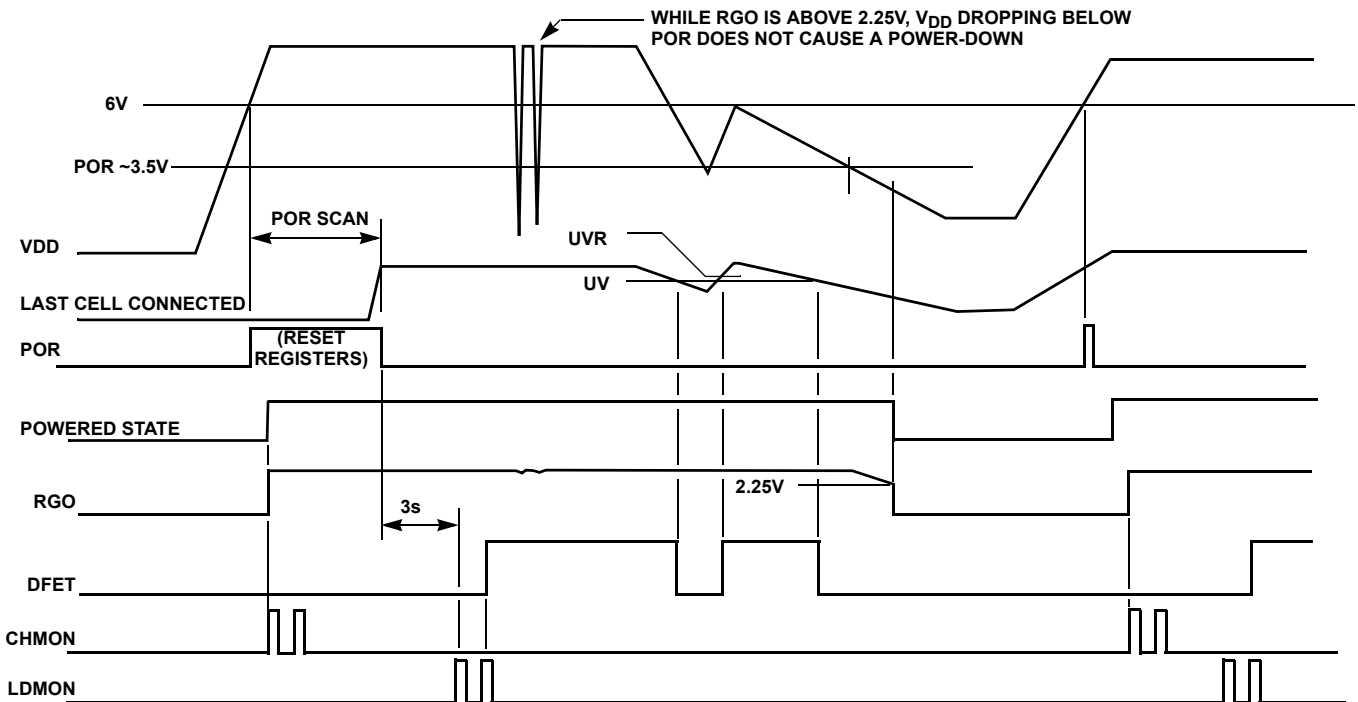

FIGURE 16. POWER-UP/POWER-DOWN/LOW VOLTAGE WAVEFORMS

## Wake-Up Circuit

When in a Sleep mode, the wake-up circuit detects that the output pin is pulled low (as might be the case when a load is attached to the pack and the FETs are off) or pulled high (as might be the case when the charger is connected and the FETs are off).

The wake-up circuit does not draw significant continuous current from the battery.

## Low Power States

In order to minimize power consumption, most circuits are kept off when not being used and items are sampled when possible.

There are five power states in the device (see [Figure 17](#)).

### NORMAL MODE

This is the normal monitoring/scan mode. In this mode, the device monitors the current continuously and scans the voltages every 32ms. If balancing is called for, then the device activates external balancing components. All necessary circuits are on and unnecessary circuits are off.

During the scan, the ISL94203 draws more current as it activates the input level shifter, the ADC and data processing. Between scans, circuits turn off to minimize power consumption.

### IDLE MODE

If there is no current flowing for 0 to 15 minutes (set in the MOD register), then the device enters the Idle mode. In this mode, voltage scanning slows to every 256ms per scan. The FETs and the LDO remain on. In this mode, the device consumes less current, because there is more time between scans.

When the ISL94203 detects any charge or discharge current, the device exits the Idle mode and returns to the Normal mode of operation.

The device does not automatically enter the Idle mode if the  $\mu$ CSCAN bit is set to "1", because the microcontroller is in charge of performing the scan and controlling the operation.

Setting the Idle bit to "1" forces the device to enter Idle mode, regardless of current flow. When a  $\mu$ C sets the Idle bit, the device remains in Idle, regardless of the timer or the current. Setting the mode control bits to 0 allows the device to control the mode.

### DOZE MODE

While in Idle mode, if there is no current flowing for another 0 to 16 minutes (same value as the idle timer), the device enters the Doze mode, where cell voltage sampling occurs every 512ms. The FETs and the LDO remain on. In this mode, the device consumes less current than Idle mode, because there is more time between scans.

When the ISL94203 detects any charge or discharge current, the device exits Doze mode and returns to the Normal mode.

The device does not automatically enter the Idle mode if the  $\mu$ CSCAN bit is set to "1", because the microcontroller is in charge of performing the scan and controlling the operation.

Setting the Doze bit forces the device to enter the Doze mode, regardless of the current flow. When a microcontroller sets the

Doze bit, the device remains in Doze mode regardless of the timer or the current. Setting the mode control bits to 0 allows the device to control the mode.

Note: Setting the Idle/Doze timer to 0 immediately forces the device into the Doze mode when there is no current.

### SLEEP MODE

The ISL94203 enters the Sleep mode when the voltage on the cells drops below the sleep voltage threshold for a period of time, specified by the Sleep Delay Timer. To prevent the device from entering the Sleep mode by a low voltage on the cells, the Sleep Voltage Level (SLL) register can be set to 0.

The device can also enter the Sleep mode from the Doze mode, if there has been no detected current for more than the duration of the Sleep mode timer (set in the MOD register). In this case, the device remains in Doze mode until there has been no current for 0 to 240 minutes (with 16 minute steps).

The external microcontroller forces the ISL94203 to enter Sleep mode by writing to the Sleep bit (Register 88H). Setting the Sleep bit forces the Sleep mode, regardless of the current flow.

Note: If both Idle/Doze and Sleep timers are set to 0, the device immediately goes to sleep. To recover from this condition, apply current to the device or hold the LDMON pin low (or CHMON pin high) and write non-zero values to the registers.

While in the Sleep mode, everything is off except for the 2.5V regulator and the wake up circuits. The device can be waken by LDMON connection to a load or CHMON connection to a charger.

### POWER-DOWN MODE

This mode occurs when the voltage on the pack is too low for proper operation. This occurs when:

- $V_{DD}$  is less than the POR threshold and  $RGO < 2.25V$ . This condition occurs if cells discharge over a long period of time.
- $V_{DD}$  is less than 1V and  $RGO > 2.25V$ . This condition can occur during a short-circuit with minimum capacity cells. The  $V_{DD}$  drops out, but the RGO cap maintains the logic supply.
- When any cell voltage is less than the UVLO threshold for more than about 160ms (and  $UVLOPD = 1$ ).
- If commanded by an external  $\mu$ C.

Recovering out of any low power state brings the ISL94203 into the Normal operating mode.

### EXCEPTIONS

There is one exception to the normal sequence of mode management. When the microcontroller sets the  $\mu$ CSCAN bit, the internal scan stops. This means that the device no longer looks for the conditions required for sleep. The external microcontroller needs to manage the modes of operation.

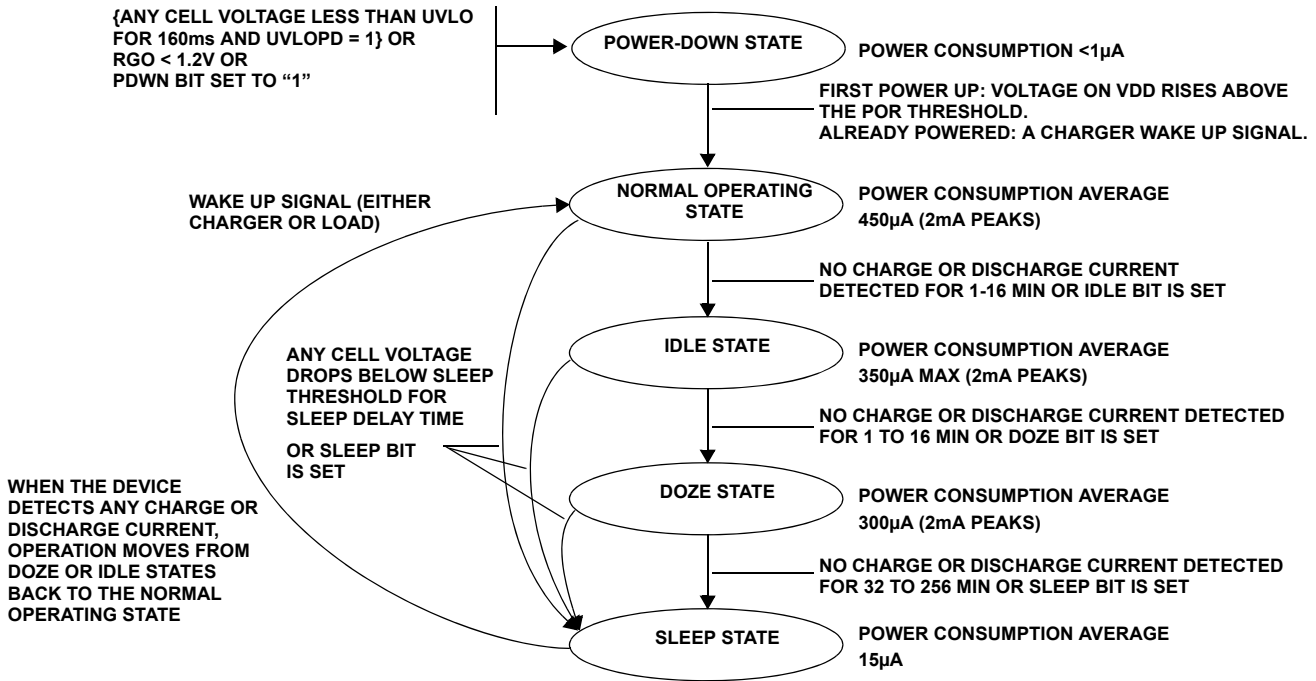

FIGURE 17. ISL94203 POWER STATES

## Typical Operating Conditions

Table 1 shows some typical device operating parameters.

TABLE 1. TYPICAL OPERATING CONDITIONS

FUNCTION	TYPICAL	UNIT
ADC Resolution	14	Bits
ADC Results Saved (and calibrated)	12	Bits
ADC Conversion Time	10	$\mu\text{s}$
Overcurrent/Short-Circuit Scan Time	Continuous	
Voltage Scan Time (Time per Cell) Includes Settling Time	125	$\mu\text{s}$
Voltage Protection Scan Rate (Time between scans) Normal Mode;	32	ms
Idle Mode	256	
Doze Mode	512	
Internal Over-temperature Turn-on/Turn-off Delay Time	128	ms
External Temperature Autoscan On Time; TEMPO = 2.5V	0.2	ms
External Temperature Autoscan Off Time; TEMPO = 0V Normal Mode	128	ms
Idle Mode	1024	
Doze Mode	2048	
Wake-Up Delay from Sleep. Time to Turn On Power FETs Following Load or Charger Connection. All Pack Conditions OK.	140	ms

TABLE 1. TYPICAL OPERATING CONDITIONS (Continued)

FUNCTION	TYPICAL	UNIT
Wake-Up Delay from Shutdown or Initial Power-Up. Time to Turn On Power FETs Following Charger Connection. All Pack Conditions OK.	3	sec
Default Idle/Doze Mode Delay Times	10	min
Default Sleep Mode Delay Time	90	min

## Cell Fail Detection

The Cell Fail (CELLF) condition indicates that the difference between the highest voltage cell and the lowest voltage cell exceeds a programmed threshold (as specified in the CBDU register). Once detected, the CELLF condition turns off the cell balance FETs and the power FETs, but only if the  $\mu\text{CFET}$  bit = "0." Setting the  $\mu\text{CFET}$  bit = "1" prevents the power FETs from turning off during a CELLF condition. The microcontroller is then responsible for the power FET control.

An EEPROM bit, CFPSD, when set to "1", enables the PSD activation when the ISL94203 detects a Cell Fail condition. When  $\text{CELLF} = "1"$  and  $\text{CFPSD} = "1"$ , the power FETs and cell balance FETs turn off, PLUS the PSD output goes active. The pack designer can use the PSD pin output to deactivate the pack by blowing a fuse.

The CELLF function can be disabled by setting the CBDU value to FFFH. In this case, the voltage differential can never exceed the limit. However, disabling the cell fail condition also disables the open-wire detection (see "Open-Wire Detection" on page 25).

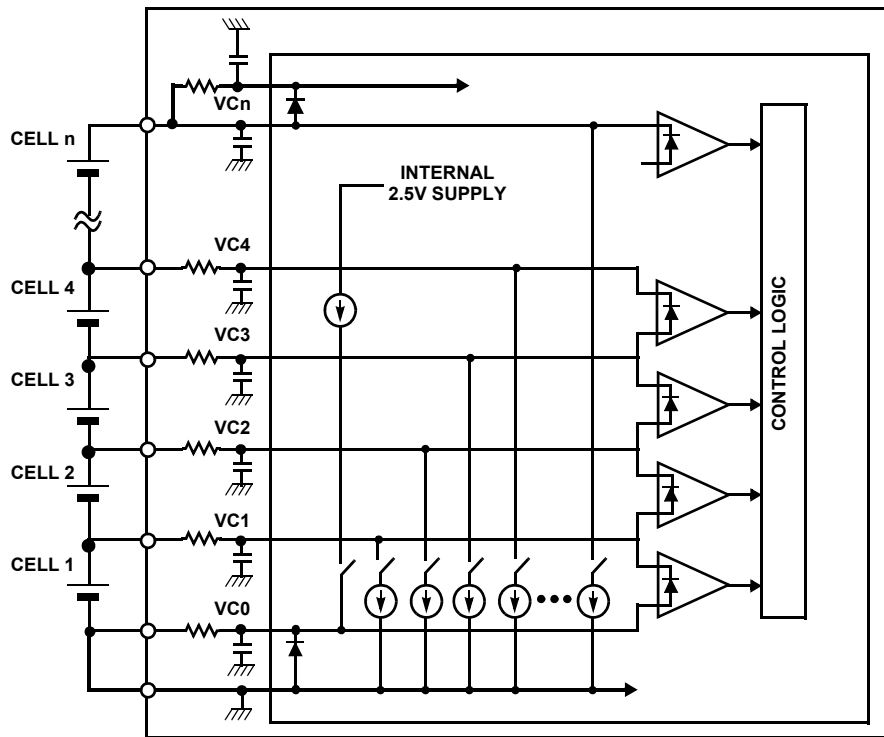

FIGURE 18. OPEN-WIRE DETECTION

NOTE: THE OPEN-WIRE TEST IS RUN ONLY IF THE DEVICE DETECTS THE CELLF CONDITION AND THEN ONCE EVERY 32 VOLTAGE SCANS WHILE A CELLF CONDITION EXISTS. EACH CURRENT SOURCE IS TURNED ON SEQUENTIALLY.

## Open-Wire Detection

There is a special open battery wire detection function on this device. The most important reason for an open-wire detection is to turn off the power FETs if there is an open wire to prevent the cells from being excessively charged or discharged.

Secondarily, the open-wire function prevents the operation of cell balancing when there is an open wire. There are two reasons for this. First, if there is an open wire, cell balancing is compromised. Second, when the cell balance turns on the external balancing FET and there is an open wire, excessive voltage may appear on the ISL94203 VCn input pins. Internal clamps and input series resistors prevent damage as a result of short term exposure to higher input voltages.

The open-wire feature uses built in circuits to force short pulses of current into or out of the input capacitors (see [Figure 18](#)). When there is no open wire, the battery cell itself changes little in response to the open-wire test.

The open-wire operation is disabled by setting a control bit (DOWD) to "1". When enabled (DOWD = "0"), the ISL94203 performs an open-wire test when the CELLF condition exists and then once every 32 voltage scans as long as the CELLF condition remains. A CELLF condition is the first indication that there might be an open wire.

In operation, the open-wire circuit pulls (or pushes) 1mA of current sequentially on each VCn input for a period of time. The open-wire on-time is programmable by a value in the OWT register. The pulse duration is programmable between 1μs and 512ms. The default values for current and time are 1mA current and 1ms duration. Note: In the absence of a battery cell, 1mA input current, along with an external capacitor of 4.7nF, changes

the voltage of the input to the open-wire threshold of -1.4V (relative to the adjacent cell) within 30μs. With the cell present, the voltage will have a negligible change.

Each input has a comparator that detects if the voltage on an input drops more than 1.4V below the voltage of the cell below. Exceptions are VC1 and VC0. For VC1, the circuit looks to see if the voltage drops below 1V. For VC0, the circuit looks to see if the voltage exceeds 1.4V. If any comparator trips, then the device sets an OPEN error flag indicating an open-wire failure and disables cell balancing. See [Figure 19](#) for sample timing.

With the open-wire setting of 1mA, input resistors of 1kΩ create a voltage drop of 1V. This voltage drop, combined with the body diode clamp of the cell balance FET, provides the -1.4V needed to detect an open wire. For this reason and for the increased protection, it is not recommended that smaller input series resistors be used. For example, with a 100Ω input resistor, the voltage across the input resistor drops only 0.1V. This will not allow the input open-wire detection hardware to trigger (although the digital detection of an open wire still works, the hardware detection automatically turns off the open-wire current).

Input resistors larger than 1kΩ may be desired to increase the input filtering. This is allowed in the open-wire test, by providing an increase in the detection time (by changing the OWT value.) However, increasing the input resistors can significantly affect measurement accuracy. The ISL94203 has up to 2μA variation in the input measurement current. This amounts to about 2mV measurement error with 1k resistors (this error has been factory calibrated out). However, 10kΩ resistors can result in up to 20mV measurement errors. To increase the input filtering, the preferred method is to increase the size of the capacitors.

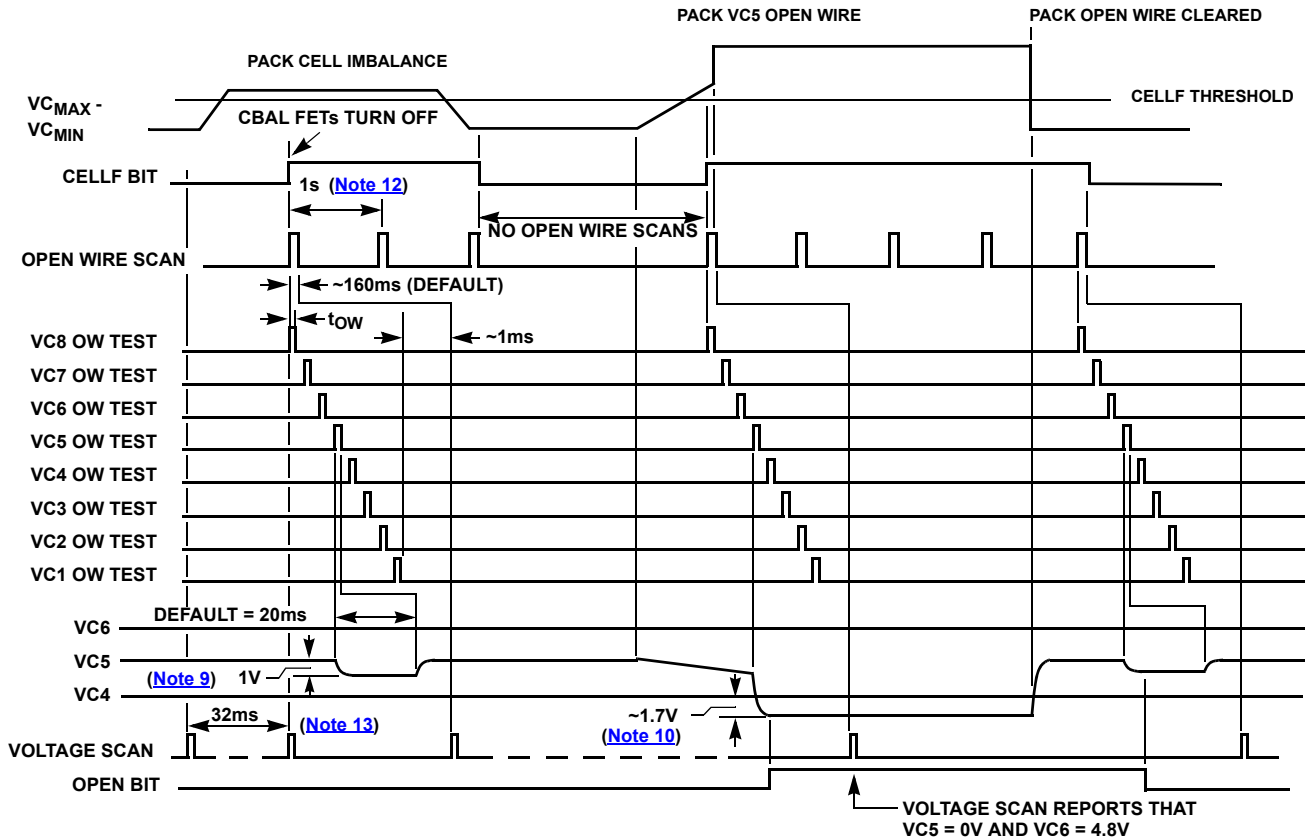

## NOTES:

9. Voltage drop =  $1\text{mA} * 1\text{k}\Omega = 1\text{V}$
10. Voltage =  $V_f$  of CB5 Balance FET body diode +  $(1\text{mA} * 1\text{k}\Omega)$
11. OWPSD bit = 0
12. This time is 8s in Idle and 16s in Doze
13. This 32ms scan rate increases to 256ms in Idle and 512ms in Doze

FIGURE 19. OPEN-WIRE TEST TIMING

Depending on the selection of the input filter components, the internal open-wire comparators may not detect an open-wire condition. This might happen if the input resistor is small. In this case, the body diode of the cell balance FET may clamp the input before it reaches the open-wire detection threshold. To overcome this limitation and provide a redundant open-wire detection, at the end of the open-wire scan, all input voltages are converted to digital values. If any digital value equals 0V (minimum) or 4.8V (maximum), the device sets an OPEN error flag indicating an open-wire failure.

When an open-wire condition occurs and the "Open-Wire Power Shutdown" (OWPSD) bit is equal to "0", the ISL94203 turns off all power FETs and the cell balance FETs, but does not set the PSD output. While in this condition, the device continues to operate normally in all other ways (i.e., the cells are scanned and the current monitored. As time passes, the device drops into lower power modes).

When an open-wire condition occurs and OWPSD = "1", the OPEN flag is set, the ISL94203 turns off all power FETs and the cell balance FETs and the ISL94203 sets the PSD output port active.

The device can automatically recover from an open-wire condition, because the open-wire test is still functional, unless the OWPSD bit equals 1 and the PSD pin blows a fuse in the pack. If the open-wire test finds that the open wire has been cleared, then OPEN bit is reset and other tests determine whether conditions allow the power FETs to turn back on.

The open-wire test hardware has two limitations. First, it depends on the CELLF indicator. If the Cell Balance Maximum Voltage Delta (CBDU) value is set to high (FFFh for example), then the device may never detect a CELLF condition. The second limitation is that the open-wire test does not happen immediately. First, a scan must detect a CELLF condition. CELLF detection happens in a maximum of 32ms (Normal mode) or in a maximum of 256ms (Doze mode). Once CELLF is detected, the open-wire test occurs on the next scan, 32ms to 256ms later.

## Current and Voltage Monitoring

There are two main automatic processes in the ISL94203. The first are the current monitor and overcurrent shutdown circuits. The second are the voltage, temperature and current analog to digital scan circuits.

### Current Monitor

The current monitor is an analog detection circuit that tracks the charge and discharge current and current direction. The current monitor circuit is on all the time, except in Sleep and Power-Down modes.

The current monitor compares the voltage across the sense resistor to several different thresholds. These are short-circuit (discharge), overcurrent (discharge) and overcurrent (charge). If the measured voltage exceeds the specified limit, for a specified duration of time, the ISL94203 acts to protect the system, as described in the following.

The current monitor also tracks the direction of the current. This is a low level detection and indicates the presence of a charge or discharge current. If either condition is detected, the ISL94203 sets an appropriate flag.

### Current Sense

The current sense element is on the high-side of the battery pack.

The current sense circuit has a gain x5, x50 or x500. The sense amplifier allows a very wide range of currents to be monitored. The gain settings allow a sense resistor in the range of 0.3mΩ to 5mΩ. A diagram of the current sense circuit is shown in [Figure 20](#).

There are two parts of the current sense circuit. The first part is a digital current monitor circuit. This circuit allows the current to be tracked by an external microcontroller or computer. The current sense amplifier gain in this current measurement is set by the [CG1:CG0] bits. The 14-bit offset adjusted ADC result of the conversion of the voltage across the current sense resistor is saved to RAM, as well as a 12-bit value that is used for threshold comparisons. The offset adjustment is based on a "factory calibration" value saved in EEPROM.

The digital readouts cover the input voltage ranges shown in [Table 2](#).

TABLE 2. MAXIMUM CURRENT MEASUREMENT RANGE

GAIN SETTING	VOLTAGE RANGE (mV)	CURRENT RANGE (R <sub>SENSE</sub> = 1mΩ)
5x	-250 to 250	-250A to 250A
50x	-25 to 25	-25A to 25A
500x	-2.5 to 2.5	-2.5A to 2.5A

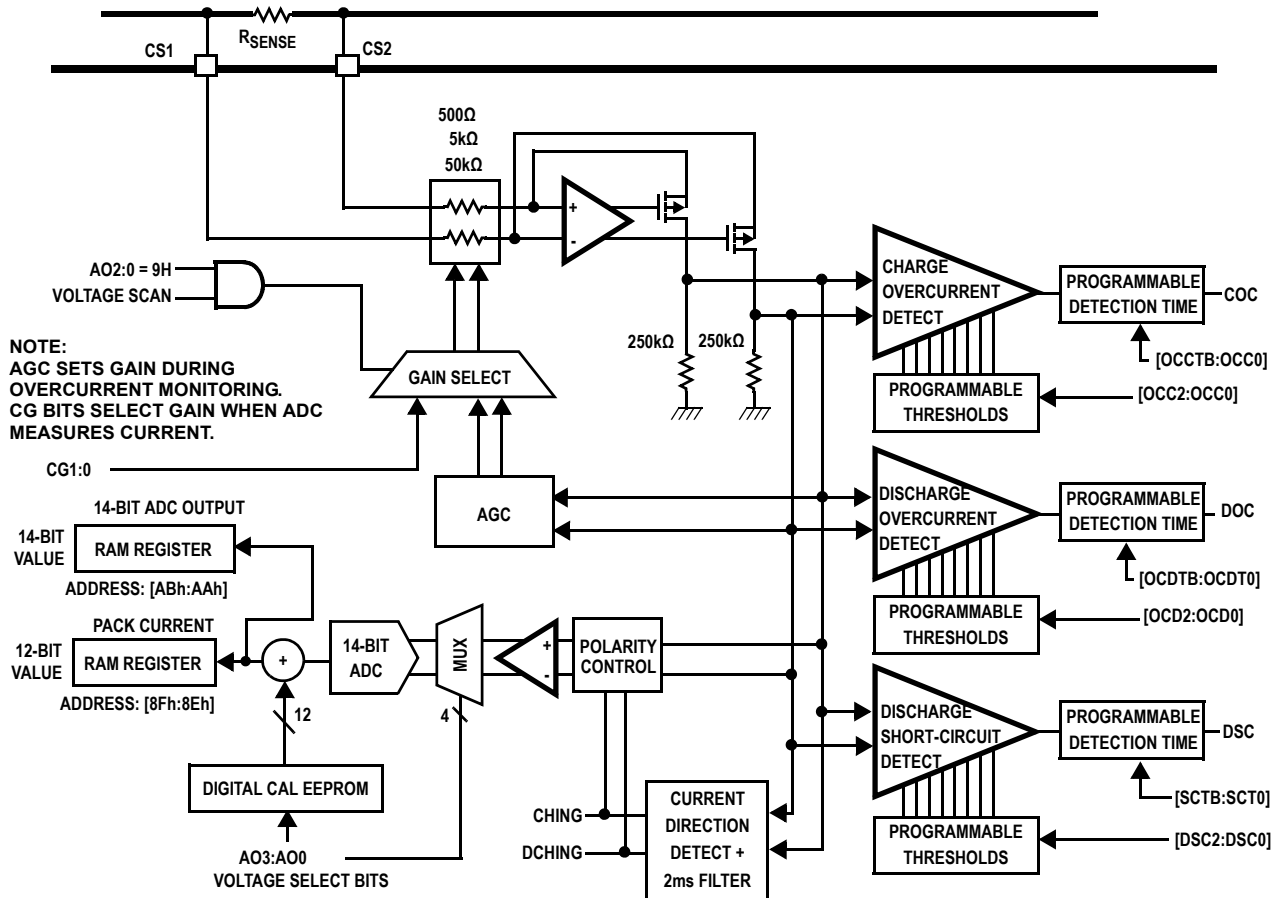

FIGURE 20. BLOCK DIAGRAM FOR OVERCURRENT DETECT AND CURRENT MONITORING

The second part is the analog current direction, overcurrent and short-circuit detect mechanisms. This circuit is on all the time. During the operation of the overcurrent detection circuit, the sense amplifier gain is automatically controlled.

For current direction detection, there is a 2ms digital delay for getting into or out of either direction condition. This means that charge current detection circuit needs to detect an uninterrupted flow of current out of the pack for more than 2ms to indicate a discharge condition. Then, the current detector needs to identify that there is a charge current or no current for a continuous 2ms to remove the discharge condition.

The overvoltage and short-circuit detection thresholds are programmable using values in the EEPROM. The discharge overcurrent thresholds are shown in [Table 3](#). The charge overcurrent thresholds are shown in [Table 4](#). The discharge short-circuit thresholds are shown in [Table 5](#).

**TABLE 3. DISCHARGE OVERCURRENT THRESHOLD VOLTAGES**

OCD SETTING	THRESHOLD (mV)	EQUIVALENT CURRENT (A)				
		0.3mΩ	0.5mΩ	1mΩ	2mΩ	5mΩ
000	4	13.3	8	4	2	0.8
001	8	26.6	16	8	4	1.6
010	16	53.3	32	16	8	3.2
011	24	80	48	24	12	4.8
100	32	106.7	64	32	16	6.4
101	48	(Note 14)	96	48	24	9.6
110	64	(Note 14)	(Note 14)	64	32	12.8
111	96	(Note 14)	(Note 14)	(Note 14)	48	19.2

NOTE:

14. These selections may not be reasonable due to sense resistor power dissipation.

**TABLE 4. CHARGE OVERCURRENT THRESHOLD VOLTAGES**

OCC SETTING	THRESHOLD (mV)	EQUIVALENT CURRENT (A)				
		0.3mΩ	0.5mΩ	1mΩ	2mΩ	5mΩ
000	1	3.3	2	1	0.5	0.2
001	2	6.7	4	2	1	0.4
010	4	13.3	8	4	2	0.8
011	6	20	12	6	3	1.2
100	8	26.6	16	8	4	1.6
101	12	40	24	12	6	2.4
110	16	53.3	32	16	8	3.2
111	24	80	48	24	12	4.8

**TABLE 5. DISCHARGE SHORT-CIRCUIT CURRENT THRESHOLD VOLTAGES**

DSC SETTING	THRESHOLD (mV)	EQUIVALENT CURRENT (A)				
		0.3mΩ	0.5mΩ	1mΩ	2mΩ	5mΩ
000	16	53.3	32	16	8	3.2
001	24	80	48	24	12	4.8
010	32	106.7	64	32	16	6.4
011	48	160	96	48	24	9.6

**TABLE 5. DISCHARGE SHORT-CIRCUIT CURRENT THRESHOLD VOLTAGES (Continued)**

DSC SETTING	THRESHOLD (mV)	EQUIVALENT CURRENT (A)				
		0.3mΩ	0.5mΩ	1mΩ	2mΩ	5mΩ
100	64	213.3	128	64	32	12.8
101	96	(Note 15)	192	96	48	19.2
110	128	(Note 15)	(Note 15)	128	64	25.6
111	256	(Note 15)	(Note 15)	Note	128	51.2

NOTE:

15. These selections may not be reasonable due to sense resistor power dissipation. Assumes short-circuit FET turn off in 10ms or less.

The Charge and Discharge overcurrent conditions and the Discharge Short-circuit condition need to be continuous for a period of time before an overcurrent condition is detected. These times are set by individual 12-bit timers. The timers consist of a 10-bit timer value and a 2-bit scale value (see [Table 6](#)).

**TABLE 6. CHARGE/DISCHARGE OVERCURRENT/SHORT-CIRCUIT DELAY TIMES**

[OCCTB:A] [OCDTB:A] [SCTB:A] SCALE VALUE	[OCCT9:0] [OCDT9:0] [SCT9:0] DELAY (10-bit VALUE)
00	0 to 1024μs
01	0 to 1024ms
10	0 to 1024s
11	0 to 1024 minutes

## Overcurrent and Short-Circuit Detection

The ISL94203 continually monitors current by mirroring the current across a current sense resistor (between the CS1 and CS2 pins) to a resistor to ground.

- A discharge overcurrent condition exists when the voltage across the external sense resistor exceeds the discharge overcurrent threshold, set by the discharge overcurrent threshold bits [OCD2:OCD0], for an overcurrent time delay, set by the discharge overcurrent time out bits [OCDTB:OCDT0]. This condition sets the DOC bit high. The LD\_PRSENT bit is also set high at this time. If the μCFET bit is 0, then the power FETs turn off automatically. If the μCFET bit is 1, then the external μC must control the power FETs.
- A charge overcurrent condition exists when the voltage across the external sense resistor exceeds the charge overcurrent threshold, set by the charge overcurrent threshold bits [OCC2:OCC0], for an overcurrent time delay, set by the discharge overcurrent time out bits [OCCTB:OCCT0]. This condition sets the COC bit high. The CH\_PRSENT bit is also set high at this time. If the μCFET bit is 0, then the power FETs turn off automatically. If the μCFET bit is 1, then the external μC must control the power FETs.
- A discharge short-circuit condition exists when the voltage across the external sense resistor exceeds the discharge short-circuit threshold, set by the discharge short-circuit threshold bits [SCD2:SCD0], for an overcurrent time delay, set

by the discharge short-circuit time out bits [SCDTB:SCDT0]. This condition sets the DSC bit high. The LD\_PRSENT bit is also set high at this time. The power FETs turn off automatically in a short-circuit condition, regardless of the condition of the  $\mu$ CFET bit.

### Overcurrent and Short-Circuit Response (Discharge)

Once the ISL94203 enters the discharge overcurrent protection or short-circuit protection mode, the ISL94203 begins a load monitor state. In the load monitor state, the ISL94203 waits three seconds and then periodically checks the load by turning on the LDMON output for 0 to 15ms every 256ms. Program the pulse duration with the [LPW3:LPW0] bits in EEPROM.

When turned on, the recovery circuit outputs a small current (~60 $\mu$ A) to flow from the device and into the load. With a load present, the voltage on the LDMON pin is low and the LD\_PRSENT bit remains set to "1". When the load rises to a sufficiently high resistance, the voltage on the LDMON pin rises above the LDMON threshold and the LD\_PRSENT bit is reset. When the load has been released for a sufficiently long period of time (two successive load sample periods) the ISL94203 recognizes that the conditions are OK and resets the DOC or DSC bits.

If the  $\mu$ CFET bit is 0, then the device automatically re-enables the power FETs by setting the DFET and CFET (or PCFET) bits to "1" (assuming all other conditions are within normal ranges). If the  $\mu$ CFET bit is 1, then the  $\mu$ C must turn on the power FETs.

An external microcontroller can override the automatic load monitoring of the device. It does this by taking control of the load monitor circuit (set the  $\mu$ CLMON bit = "1") and periodically pulsing the LMON\_EN bit. When the microcontroller detects that

LD\_PRSENT = "0", the  $\mu$ C sets the CLR\_LERR bit to "1" (to clear the error condition and reset the DOC or DSC bit) and sets the DFET and CFET (or PCFET) bits to "1" to turn on the power FETs.

### Overcurrent Response (Charge)

Once the ISL94203 enters the charge overcurrent protection mode, the ISL94203 begins a charger monitor state. In the charger monitor state, the ISL94203 periodically checks the charger connection by turning on the CHMON output for 0ms to 15ms every 256ms. Program the use duration with the [CPW3:CP0] bits in EEPROM.

When turned on, the recovery circuit checks the voltage on the CHMON pin. With a charger present, the voltage on the CHMON pin is high (>9V) and the CH\_PRSENT bit remains set to "1". When the charger connection is removed, the voltage on the CHMON pin falls below the CHMON threshold and the CH\_PRSENT bit is reset. When the charger has been released for a sufficiently long period of time (two successive sample periods) the ISL94203 recognizes that the conditions are OK and clears the COC bit.

If the  $\mu$ CFET bit is 0, the device automatically reenables the power FETs by setting the DFET and CFET (or PCFET) bits to "1" (assuming all other conditions are within normal ranges). If the  $\mu$ CFET bit is 1, then the  $\mu$ C must turn on the power FETs.

An external microcontroller can override the automatic charger monitoring of the device. It does this by taking control of the load monitor circuit (set the  $\mu$ CMMON bit = "1") and periodically pulsing the CMON\_EN bit. When the microcontroller detects that CH\_PRSENT = "0", the  $\mu$ C sets the CLR\_CERR bit to "1" (to clear the error condition and reset the COC bit) and sets the DFET and CFET (or PCFET) bits to "1" to turn on the power FETs.

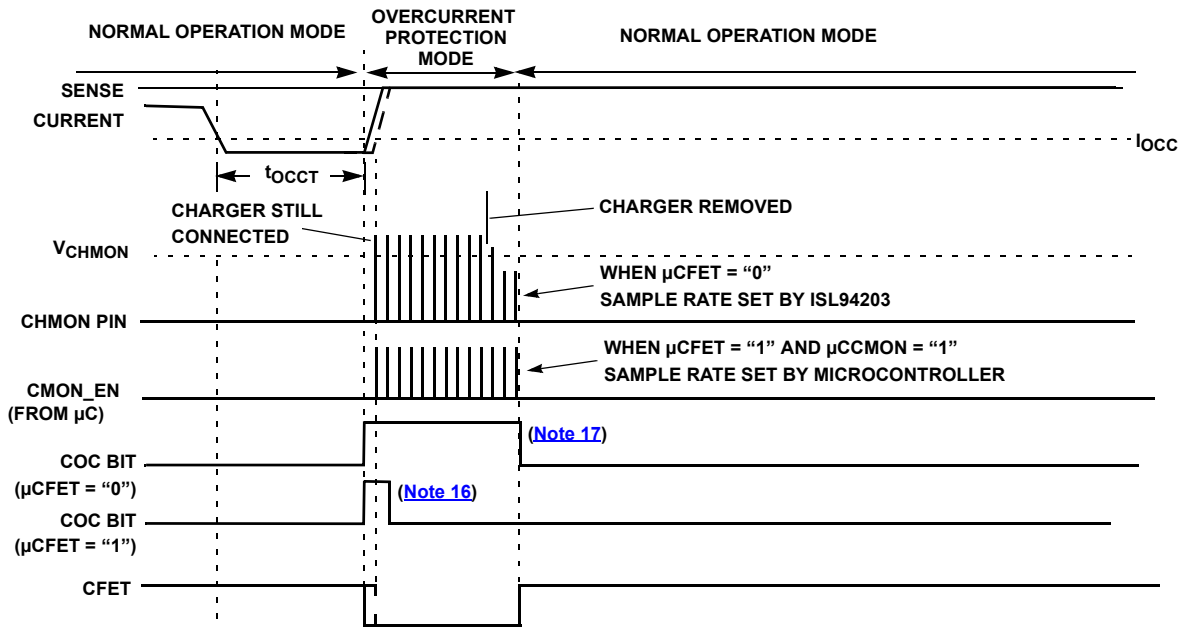

NOTES:

- 16. When  $\mu$ CFET = "1", COC bit is reset when the CLR\_CERR is set to "1".
- 17. When  $\mu$ CFET = "0", COC is reset by the ISL94203 when the condition is released

FIGURE 21. CHARGE OVERCURRENT PROTECTION MODE - EVENT DIAGRAM

## Microcontroller Overcurrent FET Control Protection

If any of the microcontroller override bits ( $\mu$ CSCAN,  $\mu$ CFET,  $\mu$ CLMON,  $\mu$ CCMON or  $\mu$ CBAL) are set to "1" and the microcontroller does not send a valid slave byte to the ISL94203

within the watchdog time out period, then the microcontroller control bits are all reset, the device turns off the power FETs and the balance FETs and the  $\overline{\text{INT}}$  output provides a 1 $\mu$ s pulse one time per second.

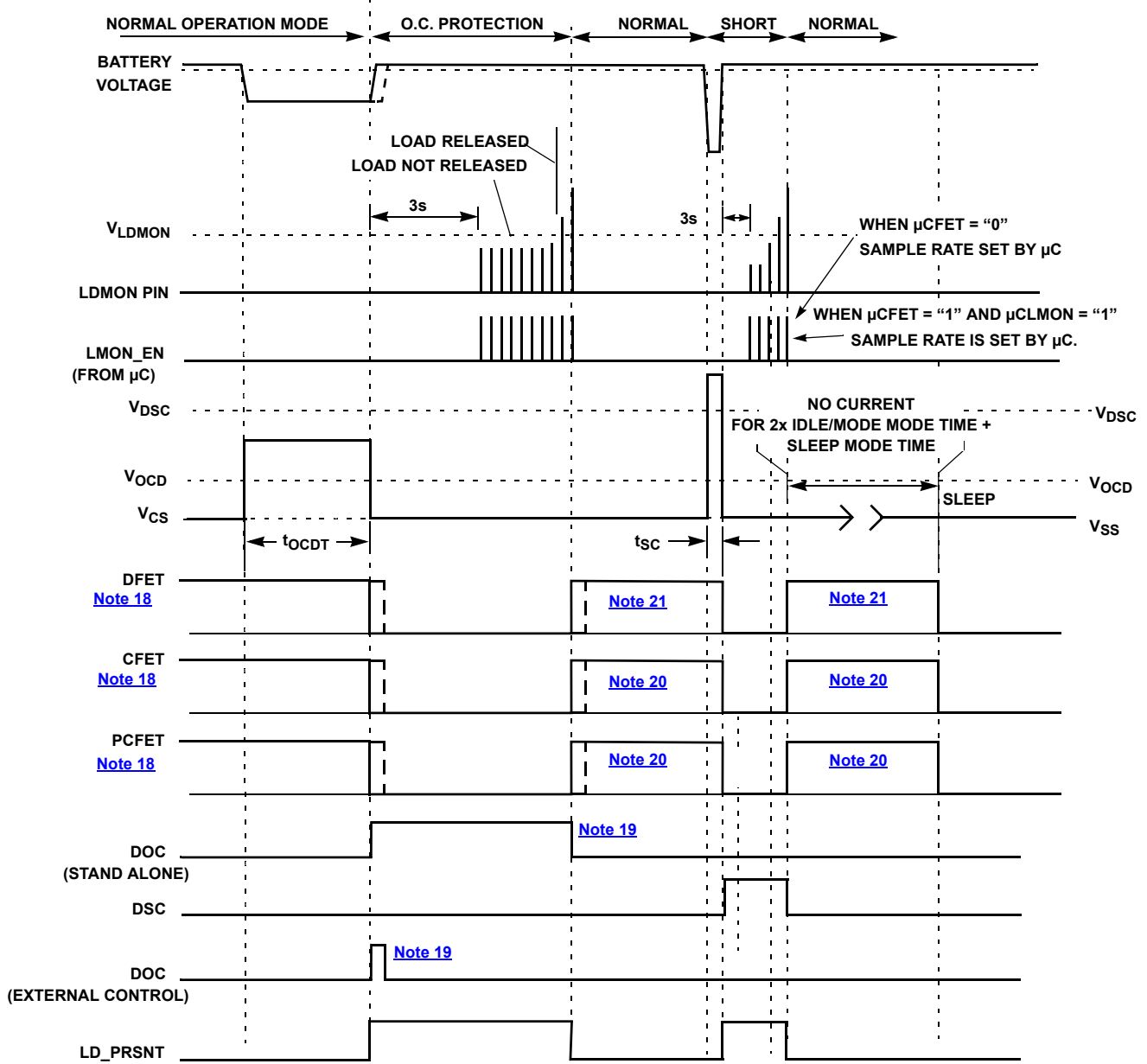

FIGURE 22. DISCHARGE OVERCURRENT PROTECTION MODE - EVENT DIAGRAM

NOTES:

- 18. When  $\mu$ CFET = "1", CFET, DFET and PCFET are controlled by external  $\mu$ C.  
When  $\mu$ CFET = "0", CFET, DFET and PCFET are controlled automatically by the ISL94203.
- 19. When  $\mu$ CFET = "1", DOC and DSC bits are reset by setting the CLR\_LERR bit.  
When  $\mu$ CFET = "0", DOC and DSC are reset by the ISL94203 when the condition is released.
- 20. PCFET turns on if any cell voltage is less than LVCHG threshold. Otherwise CFET turns on.
- 21. DFET does not turn on if any cell is less than the UV threshold, unless the DFODUV bit is set.

### Voltage, Temperature and Current Scan

The voltage scan consists of the monitoring of the digital representation of the current, cell voltages, temperatures, pack voltage and regulator voltage. This scan occurs once every 32ms, 256ms or 512ms (depending on the mode of operation, see [Figure 23](#)). The temperature, pack voltage and regulator voltage are scanned only every 4th scan. The open wire is scanned every 32nd scan as long as the CELLF condition exists.

After each measurement scan, the ISL94203 performs an offset adjustment and stores the values in RAM. After the values are stored, the state machine executes compare operations that determine if the pack is operating within limits. See [Figure 23](#) for details on the scan sequence.

During manufacture, Renesas provides calibration values in the EEPROM for each cell voltage reading. When there is a new conversion for a particular voltage, the calibration is applied to the conversion.

CURRENT/VOLTAGE MONITOR (EVERY CYCLE)

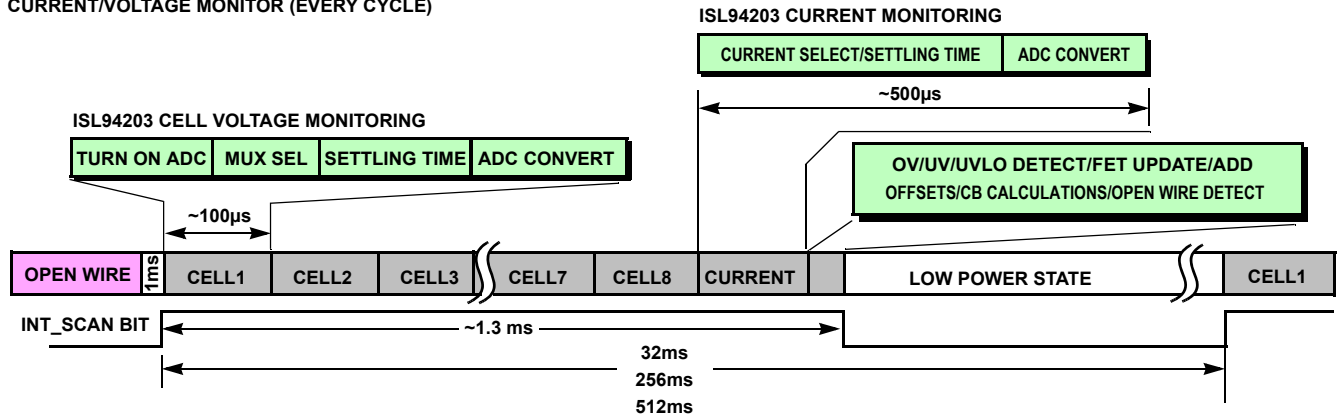

CURRENT/VOLTAGE/TEMPERATURE MONITOR (EVERY 4TH CYCLE)

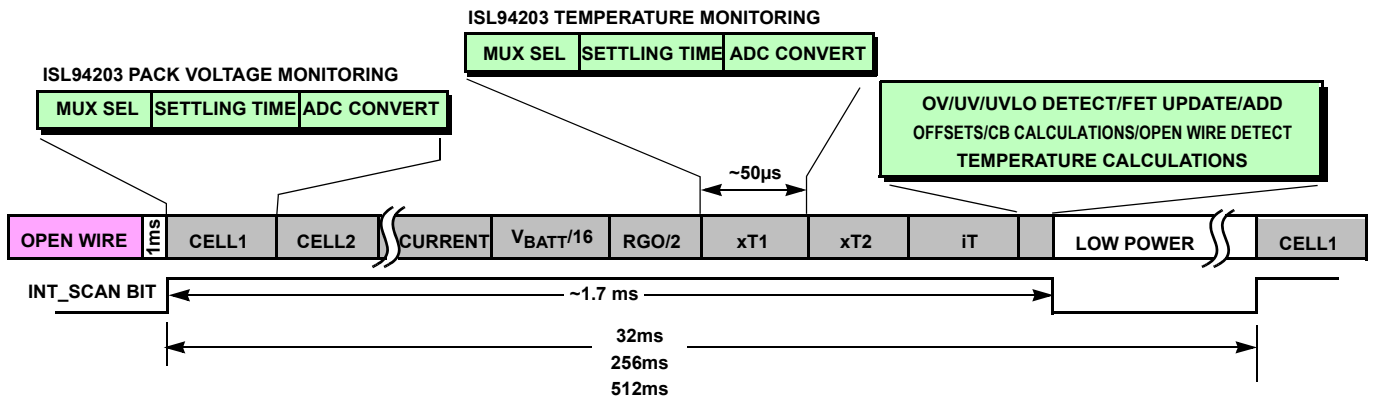

FIGURE 23. CELL VOLTAGE, CURRENT, TEMPERATURE SCANNING

NOTES:

- 22. The open-wire test performed every 32 voltage scans, if CELLF = 1, just prior to the scan.
- 23. FETs turn off immediately if there is an error, but they do not turn on until the end of the voltage scan (at "FET update" if everything else is OK). An exception to this is when a device wakes up when connected to a load. In this case, the FETs turn on immediately on wake-up, then a scan begins.
- 24. The voltage scan can be turned off by an external microcontroller by setting the µSCAN bit. This bit is monitored by the watchdog timer, so if an external microcontroller stops communicating with the ISL94203 for more than the WDT period, this bit is automatically reset and the scan resumes.

## Cell Voltage Monitoring

The circuit that monitors the input cell voltage multiplies the cell voltage by 3/8. The ADC converts this voltage to a digital value, using a 1.8V internal reference. The ADC produces a calibrated 14-bit value, but only 12 bits are stored in the cell registers (see [Figure 24](#).)

In manufacturing, each cell voltage is calibrated at 3.6V per cell and at +25 °C. This calibrated value is used for all subsequent voltage threshold comparisons.

The ISL94203 has two different overvoltage and undervoltage level comparisons, OVLO/UVLO and OV/UV. While both use the ADC converter output values and a digital comparator, the responses are different. The OVLO and UVLO levels are meant to be secondary thresholds above and below the OV and UV thresholds.

### UVLO AND OVLO

OVLO and UVLO, because they provide a secondary safety condition, can cause the pack to shut down, either permanently, as is the case of an OVLO when the PSD pin connects to an external fuse; or severely, as is the case of an UVLO when the device powers down and requires connection to a charger to recover.

The OVLO condition can be overridden by setting the OVLO threshold to FFFh or by an external  $\mu$ C setting the  $\mu$ CSCAN bit to override the internal automatic scan, then turning on the CFET. However, if the  $\mu$ C takes permanent control of the scan, the  $\mu$ C needs to take over the scan for all cells and all control functions, including comparisons of the cell voltage to OV and UV thresholds, managing time delays and controlling all cell balance functions.

The UVLO response can be overridden by setting the UVLO threshold to 0V. The device can respond to the UVLO condition by entering the Power-Down mode (set UVLOPD in EEPROM to "1")

or by turning off the FETs and setting the UVLO bit (UVLOPD = "0").

When the UVLOPD bit is set to "1" (indicating that the ISL94203 should power down during a UVLO condition) and the  $\mu$ CFET bit is set to "1" (indicating that the  $\mu$ C is in control of the FETs), the automatic UVLO control forces a power-down condition, overriding the  $\mu$ C FET control.

The UVLO and OVLO detection both have delays of 5 sample cycles (typically 160ms) to prevent noise generated entry into the mode.

The OVLO and UVLO values are each set by 12-bit values in EEPROM.

The OVLO has a recovery threshold of OVR and UVLO has a recovery threshold of UVR (if the response overrides have been set). If the response overrides are not set, then the recovery thresholds are usually irrelevant; for example, when the UVLO forces the device into a power down condition or the OVLO condition caused a PSD controlled fuse to blow.

### UV, OV AND SLEEP

UV, OV and SLP thresholds are set by individual 12-bit values.

UV and OV recovery thresholds are set by individual 12-bit values.

The voltage protection scan occurs once every 32ms in normal operation. If there has been no activity (no charge or discharge current) detected in a programmable period of 1 to 16 minutes, then the scan occurs every 256ms (Idle mode). If no charge or discharge condition has been detected in Idle mode for the programmable period, then the scan occurs every 512ms.

If an overvoltage, undervoltage or sleep condition is detected and is pending, the scan rate remains unchanged. It can take longer to detect the fault condition in Idle or Doze modes. The scan rate is determined by the mode of operation and the mode of operation is determined solely by the time since pack charge/discharge current was detected.

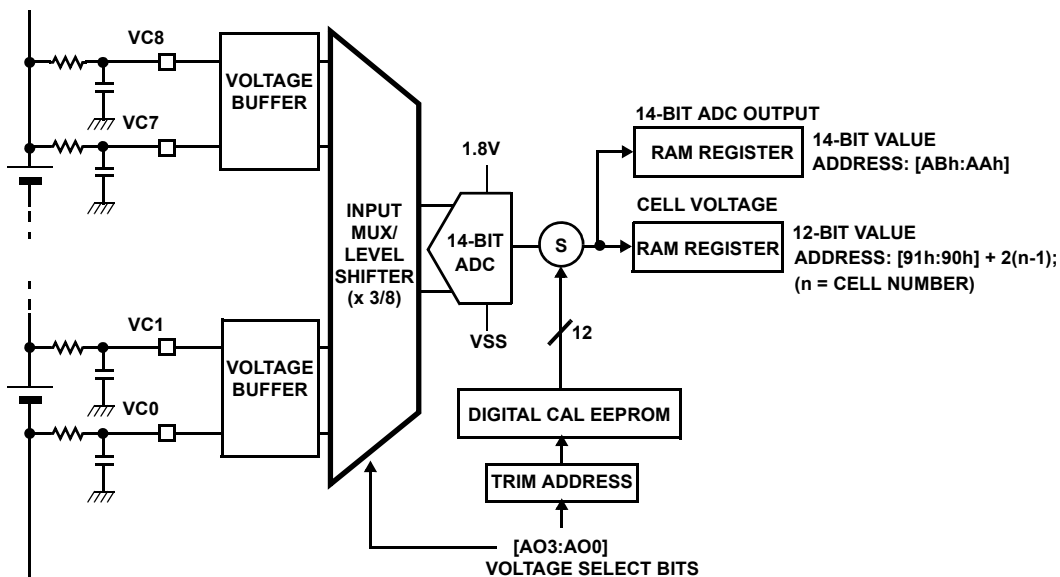

FIGURE 24. BLOCK DIAGRAM OF CELL VOLTAGE CAPTURE

During a scan, each cell is monitored for overvoltage, undervoltage and sleep voltage. The voltage will also be converted to an ADC value and be stored in memory.

If, during the scan, a voltage is outside the set limit, then a timer starts. There is one timer for all of the cells. If the condition remains on any cell or combination of cells for the duration of the time period, an error condition exists. This sets the appropriate flag and notifies the protection circuitry to take action (if automatic action is enabled).

The time out delays for OV, UV and Sleep are each 12-bit values stored in EEPROM (see [Table 7](#)).

TABLE 7. OV, UV, SLEEP DELAY TIMES

SCALE VALUE	DELAY (10-BIT VALUE)
00	0 to 1024µs
01	0 to 1024ms
10	0 to 1024s
11	0 to 1024min

The control logic for overvoltage, undervoltage and sleep conditions is shown in [Table 7](#) and [Figures 25](#) and [26](#).

### Overvoltage Detection/Response

The device needs to monitor the voltage on each battery cell ( $V_{Cn}$ ). If for any cell,  $[V_{Cn} - VC(n-1)] > V_{OV}$  for a time exceeding  $t_{OV}$ ,

the device sets an OV flag. Then (if  $\mu CFET = 0$ ), the ISL94203 turns the charge FET OFF, by setting the CFET bit to "0". Once the OV flag is set the pack has entered Overcharge Protection mode. The status of the discharge FET remains unaffected.

The charge FET remains off until the voltage on the overcharged cell drops back below a recovery level,  $V_{OVR}$ , for a recovery time period,  $t_{OVR}$ . The  $t_{OVR}$  time equals the  $t_{OV}$  time.

Note: The detection timer and recovery timer are asynchronous to the voltage threshold. As a result, a setting of 1s can result in a delay time of 1s to 2s, depending on when the OV/OVR is detected. For a setting of 1000ms, the detection time will be within 1ms.

The device further continues to monitor the battery cell voltages and is released from overcharge protection mode when  $[V_{Cn} - VC(n-1)] < V_{OVR}$  for more than the overcharge release time, for all cells.

When the device is released from overcharge protection mode, the charge FET is automatically switched ON (if  $\mu CFET = 0$ ). When the device returns from Overcharge Protection mode, the status of the discharge FET remains unaffected.

During charge, if the voltage on any cell exceeds an End Of Charge threshold (EOCS) then an EOCHG bit is set and the  $\overline{EOC}$  output is pulled low. The EOCHG bit and the  $\overline{EOC}$  output resume normal conditions when the voltage on all cells drops back below the [EOCS - 117mV] threshold.

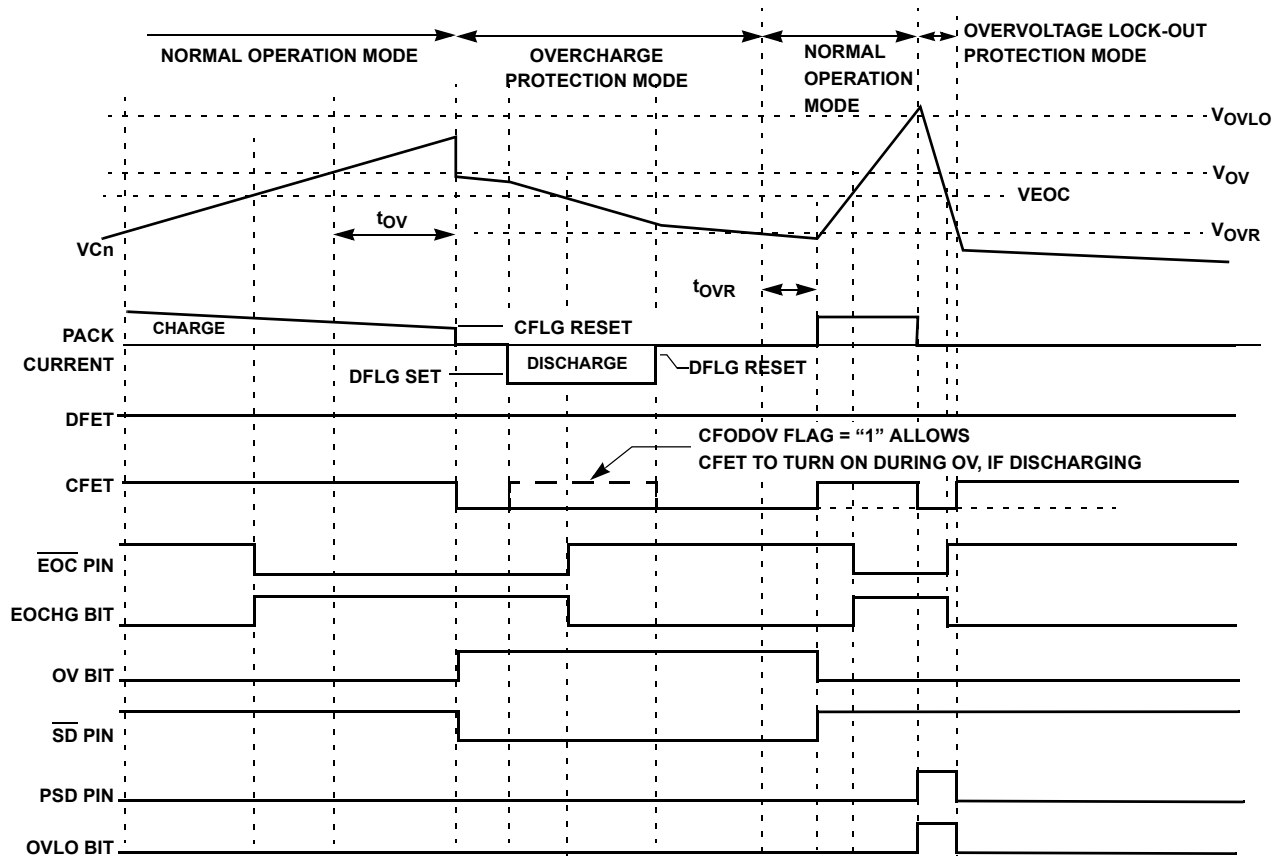

FIGURE 25. OVERVOLTAGE PROTECTION MODE-EVENT DIAGRAM

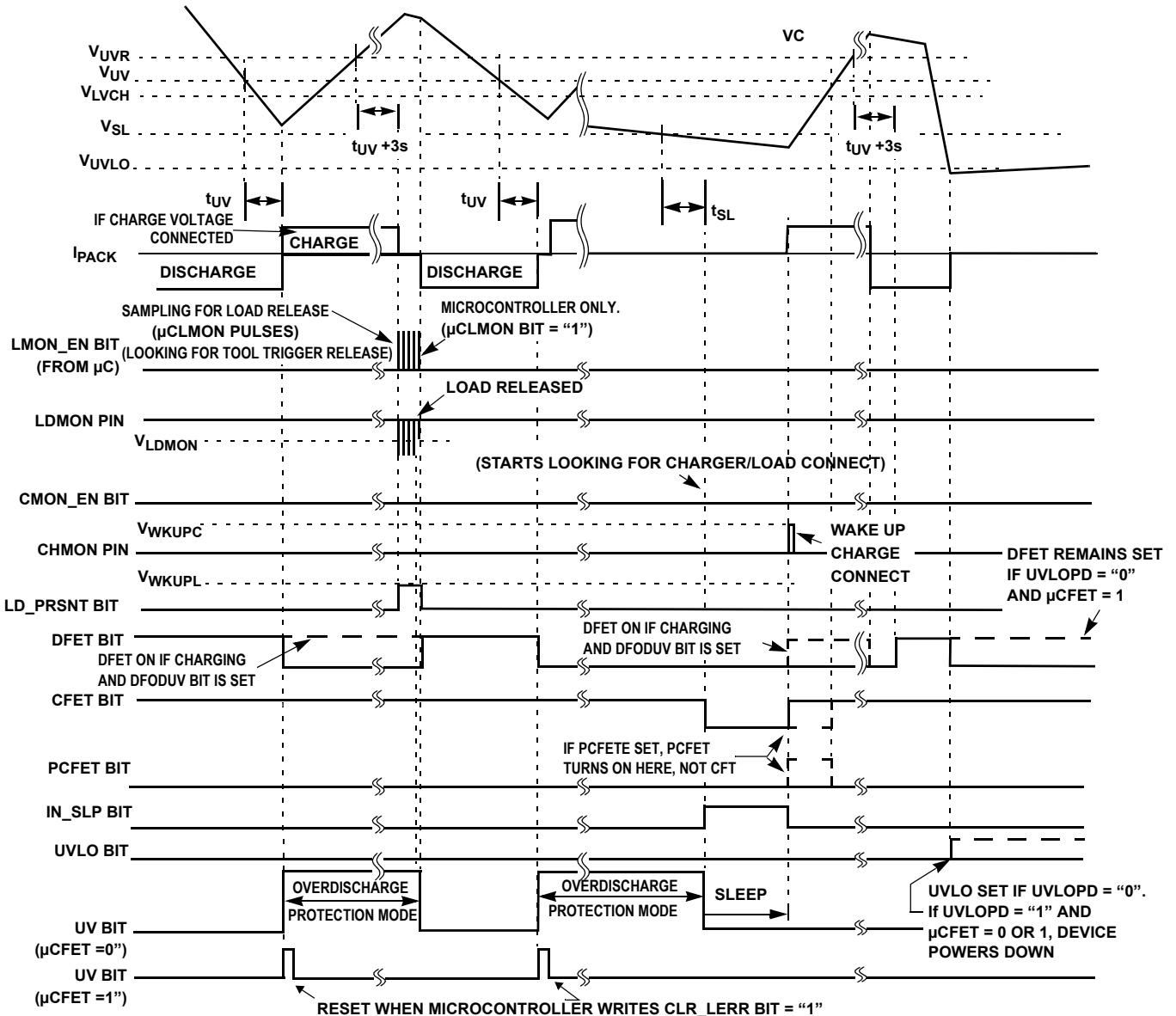

FIGURE 26. UNDERVOLTAGE PROTECTION MODE-EVENT DIAGRAM

There is also an overvoltage lockout. When this level is reached, an OVLO bit is set, the PSD output is set and the charge FET or precharge FET is immediately turned off (by setting the CFET or PCFET bit to "0"). The PSD output can be used to blow a fuse to protect the cells in the pack.

If, during an OV condition, the μCFET bit is set to "1", the microcontroller must control both turn off and turn on of the charge and precharge power FETs. This does not apply to the OVLO condition.

The device includes an option to turn the charge FET back on in an overvoltage condition, if there is discharge current flowing out of the pack. This option is set by the CFODOV (CFET ON During Overvoltage) Flag stored in EEPROM. Then, if the discharge current stops and there is still an overcharge condition on the cell, the device again disables the charge FET.

### Undervoltage Detection/Response

If  $V_{Cn} < V_{UV}$ , for a time exceeding  $t_{UVT}$ , the cells are said to be in an over discharge (undervoltage) state. In this condition, the ISL94203 sets a UV bit. If the μCFET bit is set to "0", the ISL94203 also switches the discharge FET OFF (by setting the DFET bit = "0").

While any cell voltage is less than a low voltage charge threshold and if the PCFETE bit is set, the PCFET output is turned on instead of the CFET output. This enables a precharge condition to limit the charge current to undervoltage cells.

From the undervoltage mode, if the cells recover to above a  $V_{UVR}$  level for a time exceeding  $t_{UVT}$  plus three seconds, the ISL94203 pulses the LD\_MON output once every 256ms and looks for the absence of a load. The pulses are of programmable duration (0ms to 15ms) using the [LPW3:LPW0] bits. During the pulse period, a small current (~60μA) is output into the load. If there is

no load, then the LDMON voltage will be higher than the recovery threshold of 0.6V. When the load has been removed and the cells are above the undervoltage recovery level, the ISL94203 clears the UV bit and (if  $\mu\text{CFET} = 0$ ) turns on the discharge FET and resumes normal operation.

Note: The  $t_{UV}$  detection timer and  $t_{UVR}$  recovery timer are asynchronous to the voltage threshold. As a result, a setting of 1s can result in a delay time of 1s to 2s (and a recovery time of 3s to 4s), depending on when the UV/UVR is detected. For a setting of 1000ms, the detection time will be within 1ms.

If any of the cells drop below a sleep threshold ( $V_{Cn} < V_{SLP}$ ) for a period of time ( $t_{SLT}$ ), the device sets the Sleep bit and (if  $\mu\text{CFET} = 0$ ) the ISL94203 turns off both FETs (DFET and CFET = "0") and puts the pack into a Sleep mode by setting the Sleep bit to "1". If the  $\mu\text{CFET}$  bit is set, the device does not go to sleep.

There is also an undervoltage lockout condition. This is detected by comparing the cell voltages to a programmable UVLO threshold. When any cell voltage drops below the UVLO threshold and remains below the threshold for 5 voltage scan periods (~160ms), a UVLO bit is set and the  $\overline{SD}$  output pin goes active. If UVLOPD = 0 and  $\mu\text{CFET} = 0$ , the DFET is also turned off. If UVLOPD = 1, then the ISL94203 goes into a power-down state.

If the  $\mu\text{CFET}$  bit is set to "1", the microcontroller must both turn off and turn on the discharge power FETs and control the sleep and power-down conditions.

The device includes an option to turn the discharge FET back on in an undervoltage condition, if there is a charge current flowing into the pack. This option is set by the DFODUV (DFET ON During Undervoltage) Flag stored in EEPROM. Then, if the charge current stops and there is still an undervoltage condition on the cell, the device again disables the discharge FET.

**Temperature Monitoring/Response**

As part of the normal voltage scan, the ISL94203 monitors both the temperature of the device and the temperature of two external temperature sensors. External temperature 2 can be used to monitor the temperature of the FETs, instead of the cells, by setting the xT2M bit to "1".

The temperature voltages have two gain settings (the same gain for all temperature inputs). For external temperatures, a TGain bit = 0, sets the gain to 2x (full scale input voltage = 0.9V), see

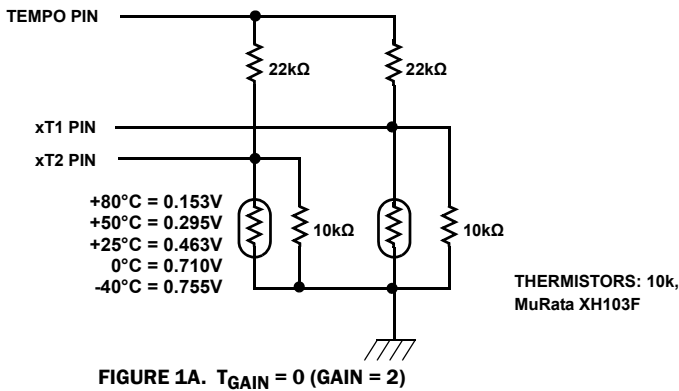

FIGURE 1A. TGAIN = 0 (GAIN = 2)

Figure 1A. A TGain bit = 1 and sets the gain to 1x (full scale input voltage = 1.8V). See Figure 1B.

The default temperature gain setting is x2, so the temperature monitoring circuit of Figure 27A is preferred. This configuration has other advantages. The temperature response is more linear and covers a wider temperature range before nearing the limits of the ADC reading.

The internal temperature reading converts from voltage to temperature using Equations 1 and 2:

$$TGain = 1 \quad \frac{intTemp(mV) \times 1000}{0.92635} - 273.15 = ICTemp(^{\circ}C) \quad (EQ. 1)$$

$$TGain = 0 \quad \frac{intTemp(mV) \times 1000}{1.8527} - 273.15 = ICTemp(^{\circ}C) \quad (EQ. 2)$$

If the temperature of the IC (Internal Temp) goes above a programmed over-temperature threshold, then the ISL94203 sets an over-temp flag (IOT), prevents cell balancing and turns off the FETs.

**OVER-TEMPERATURE**

If the temperature of either of the external temperature sensors (xT1 or xT2), as determined by an external resistor and thermistor, goes below any of the thresholds (charge, discharge and cell balance as set by internal EEPROM values), indicating an over-temperature condition, the ISL94203 sets the corresponding over-temp flag.

If the automatic responses are enabled ( $\mu\text{CFET} = 0$ ), the Charge Over-Temperature (COT) or Discharge Over-Temperature (DOT) flag is set and the corresponding charge or discharge FET is turned off. If the Cell Balance Over-Temperature (CBOT) flag is set, the device turns off the balancing outputs and prevents cell balancing while the condition exists.

If the automatic responses are disabled ( $\mu\text{CFET} = 1$ ) then the ISL94203 only sets the flags and an external microcontroller responds to the condition.

An exception to the above occurs if the xT2 sensor is configured as a FET temperature indicator (XT2M = "1"). In this case, the xT2 is not compared to the cell balance temperature thresholds, it is used only for power FET control.

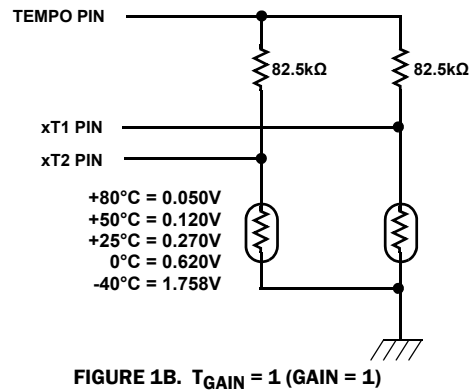

FIGURE 1B. TGAIN = 1 (GAIN = 1)

FIGURE 27. EXTERNAL TEMPERATURE CIRCUITS

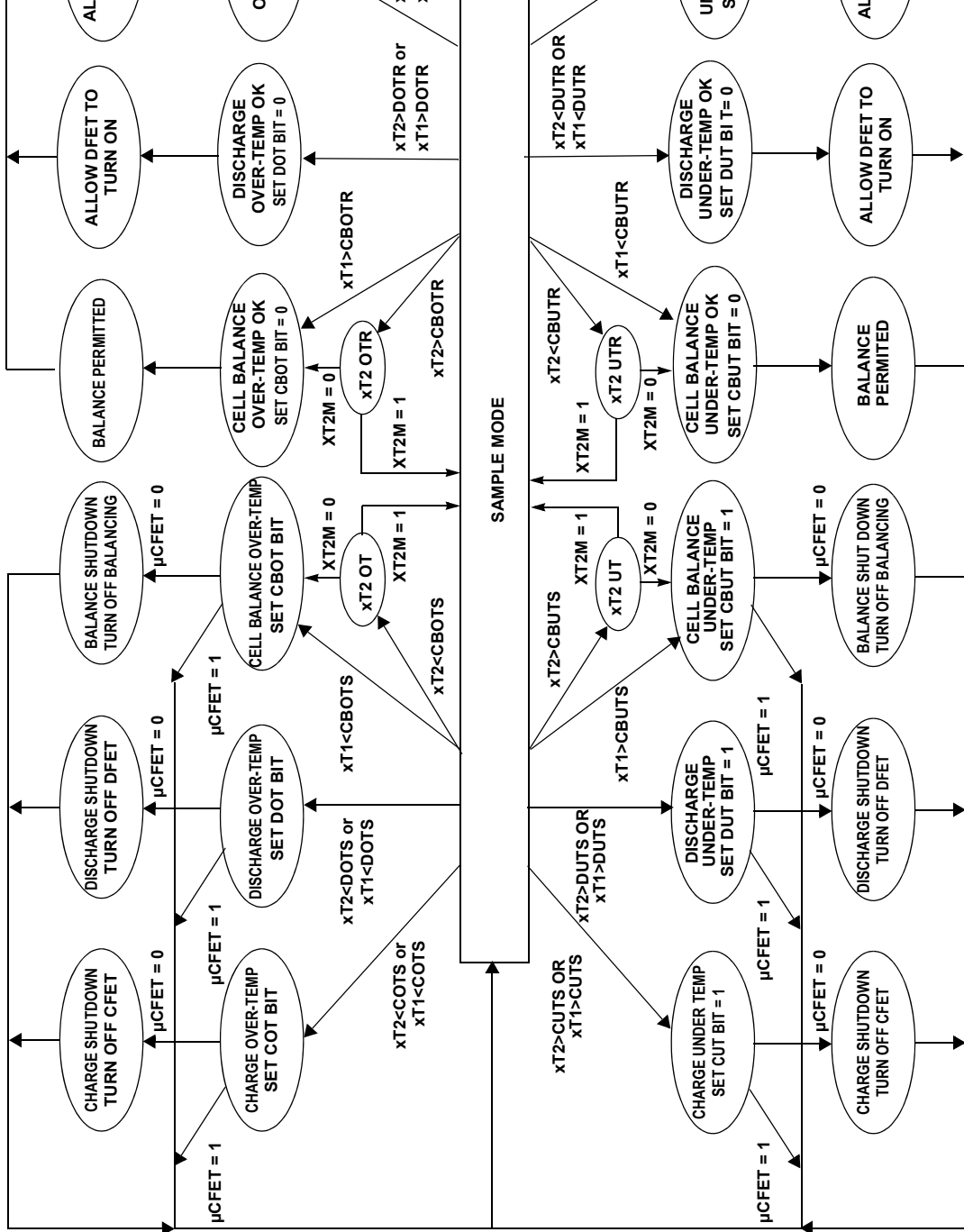

FIGURE 28. TEMPERATURE MANAGEMENT STATE MACHINE

## UNDER-TEMPERATURE

If the temperature of either of the external temperature sensors (xT1 or xT2), as determined by an external resistor and thermistor, goes above any of the thresholds (charge, discharge and cell balance as set by internal EEPROM values), indicating an under-temperature condition, the ISL94203 sets the corresponding under-temperature flag.

If the xT1 automatic responses are enabled ( $\mu\text{CFET} = 0$ ), then the Charge Under-Temperature (CUT) or Discharge Under-Temperature (DUT) flag is set the corresponding charge or discharge FET is turned off. If the Cell Balance Under-Temperature (CBUT) flag is set, the device turns off cell balancing outputs and prevents cell balancing.

If the xT2 automatic responses are disabled ( $\mu\text{CFET} = 1$ ) then the ISL94203 only sets the flags and an external microcontroller responds to the condition.

An exception to the above occurs if the xT2 sensor is configured as a FET temperature indicator (XT2M = "1"). In this case, the xT2 is not compared to the cell balance temperature thresholds. It is used only for power FET control).

For both xT1 and xT2, when the temperature drops back within a normal operating range, the over- or under-temperature condition is reset.

## Microcontroller Read of Voltages

An external microcontroller can read the value of any of the internally monitored voltages independently of the normal voltage scan. To do this requires that the  $\mu\text{C}$  first set the  $\mu\text{CSCAN}$  bit. This stops the internal scan and starts the watchdog timer. If the  $\mu\text{C}$  maintains this state, then communication must continue and the  $\mu\text{C}$  must manage all voltage and current pack control operations as well as implement the cell balance algorithms. However, if the  $\mu\text{CSCAN}$  bit remains set for a short period of time, the device continues to monitor voltages and control the pack operation.

Once the  $\mu\text{CSCAN}$  bit is set, the external  $\mu\text{C}$  writes to register 85H to select the desired voltage and to start the ADC conversion (set the ADCSTRT bit to 1 to start an ADC conversion). Once the conversion is complete, the results are read from the ADC registers [ADCD:ADC0]. The result is a 14-bit value. The ADC conversion takes about 100 $\mu\text{s}$  or the  $\mu\text{C}$  can poll the I<sup>2</sup>C link waiting for an ACK to indicate that the ADC conversion is complete.

If the  $\mu\text{CSCAN}$  bit is set when the ISL94203 internal scan is scheduled, then the internal scan pauses until the  $\mu\text{CSCAN}$  bit is cleared and the internal scan occurs immediately.

Reading an ADC value from the  $\mu\text{C}$  requires the following sequence (and time) to complete:

TABLE 8.  $\mu\text{C}$  CONTROLLED MEASUREMENT OF INDIVIDUAL VOLTAGES

STEP	OPERATION	NUMBER I <sup>2</sup> C CYCLES	TIME AT 400kHz I <sup>2</sup> C CLK (ea.) ( $\mu\text{s}$ )	TIME (CUMULATIVE) ( $\mu\text{s}$ )
1	Set $\mu\text{CSCAN}$ bit	29	72.5	72.5
2	Set voltage and start ADC	29	72.5	145
3	Wait for ADC complete	N/A	110	255
4	Read register AB	29	72.5	327.5
5	Read register AA	29	72.5	410
6	Clear $\mu\text{CSCAN}$ bit	29	100	472.5

To sample more than one time (for averaging) repeat steps 2 through 5 as many times as desired. However, if this is a continuous operation, care must be taken to monitor other pack functions or to pause long enough for the ISL94203 internal operations to collect data to control the pack. A burst of five measurements takes about 1.8ms.

## Voltage Conversions

To convert from the digital value stored in the register to a "real world" voltage, the following conversion equations should be used.

The term "HEXvalue<sub>10</sub>" means the Binary to Decimal conversion of the register value.

## CELL VOLTAGES

$$\text{Cell Voltage} = \frac{\text{HEXvalue}_{10} \times 1.8 \times 8}{4095 \times 3} \quad (\text{EQ. 3})$$

The cell voltage conversion equation is also used to set the voltage thresholds.

## PACK CURRENT

$$\text{Pack Current} = \frac{\text{HEXvalue}_{10} \times 1.8}{4095 \times \text{Gain} \times \text{SenseR}} \quad (\text{EQ. 4})$$

Gain is the gain setting in register 85H, set by the [CG1:CG0] bits.

SenseR is the sense resistor value in Ohms.

This pack current reading is valid only when the current direction indicators show that there is a charge or discharge current. If the current is too low for the indicators to show current flowing, then use the 14-bit value to estimate the current. [See "14-bit Register" on page 38.](#)

## TEMPERATURE

$$\text{Temperature} = \frac{\text{HEXvalue}_{10} \times 1.8}{4095} \quad (\text{EQ. 5})$$

[Equation 5](#) converts the register value to a voltage, but the temperature then is converted to a temperature depending on the external arrangement of thermistor and resistors. See ["Temperature Monitoring/Response" on page 35.](#)

## 14-BIT REGISTER

If  $\text{HEXvalue}_{10}$  is greater than or equal to 8191, then:

$$\text{14-bit value} = \frac{(\text{HEXvalue}_{10} - 16384) \times 1.8}{8191} \quad (\text{EQ. 6})$$

If  $\text{HEXvalue}_{10}$  is less than 8191, then:

$$\text{14-bit value} = \frac{\text{HEXvalue}_{10} \times 1.8}{8191} \quad (\text{EQ. 7})$$

Once the voltage value is obtained, if the measurement is a cell voltage, then the value should be multiplied by 8/3. A temperature value is used “as-is”, but the voltage value is converted to temperature by including the external temperature circuits into the conversion.

To determine pack current from this 14-bit value requires the following computations.

First, if both current direction flags show zero current, then the external controller must apply an offset. Measure the 14-bit voltage when there is a pack current of 0. Then subtract this offset from the 14-bit current sense measurement value and take the absolute value of the result. If either of the current direction flags indicate a current, then do not subtract the offset value, but use the 14-bit value directly. In either case, divide the 14-bit voltage value by the current sense gain and the current sense resistor to arrive at the pack current.

## Microcontroller FET Control

The external microcontroller can override the device control of the FETs. With the  $\mu\text{CFET}$  bit set to “1”, the external microcontroller can turn the FETs on or off under all conditions except the following:

- If there is a discharge short-circuit condition, the device turns the FETs off. The external microcontroller is responsible for turning the FETs back on once the short-circuit condition clears.
- If there is an internal over-temperature condition, the device turns the FETs off. The external microcontroller is responsible for turning the FETs back on once the temperature returns to within normal operating limits.
- If there is an overvoltage lockout condition, the device turns the charge or precharge FETs off. The external microcontroller is responsible for turning the FETs back on, once the OVLO condition clears. This assumes that the PSD output has not blown a fuse to disable the pack.
- If there is an open-wire detection, the device turns the FETs off. The external microcontroller is responsible for turning the FET back on. This assumes that the open wire did not cause the PSD output to blow a fuse to disable the pack.
- If the FETSOFF input is HIGH, the FETs turn off and remain off. The external  $\mu\text{C}$  is responsible for turning the FETs on once the FETSOFF condition clears.

- If there is a sleep condition, the device turns the FETs off. On wake up, the microcontroller is responsible for turning on the FETs.

The microcontroller can also control the FETs by setting the  $\mu\text{CSCAN}$  bit. However, this also stops the scan, requiring the microcontroller to manage the scan, voltage comparisons, FET control and cell balance. While the  $\mu\text{CSCAN}$  bit is set to “1”, the only operations controlled by the device are:

- Discharge short-circuit FET control. The external  $\mu\text{C}$  cannot override the turn off of the FETs during the short-circuit.
- FETSOFF external control. The FETSOFF pin has priority on control of the FETs, even when the microcontroller is managing the scan.
- In all other cases, the microcontroller must manage the FET control, because it is also managing the voltage scan and all comparisons.

## Cell Balance

At the same rate as the scan of the cell voltages, if cell balancing is on, the system checks for proper cell balance conditions. The ISL94203 prevents cell balancing if proper temperature, current and voltage conditions are not met. The cells only balance during a CBON time period. When the CBOFF timer is running, the cell balance is off. Three additional bits determine whether the balancing happens only during charge, only during discharge, during both charge and discharge, during the end of charge condition or not at any time.

- The cell balance circuit depends on the 14-bit ADC converter built into the device and the results of the cell voltage scan (after calibration).
- The ADC converter loads a set of registers with each cell voltage during every cell voltage measurement.
- At the end of the cell voltage measurement scan, the ISL94203 updates the minimum (CELMIN) and maximum (CELMAX) cell voltages.
- After calculating the CELMIN and CELMAX values, all of the cell voltages are compared with the CELMIN value. When any of the cells exceed CELMIN by CBDL (the minimum CB delta voltage), a flag is set in RAM indicating that the cell needs balancing (this is the CBnON bit).
- If any of the cells exceed the lowest cell by CBDU (maximum CB delta voltage) then a flag is set indicating that a Cell voltage failure occurred (CELLF).
- When the CELLF flag indicates that there is too great a cell to cell differential, the balancing is turned off.
- If CELMAX is below CBMIN (all the cell voltages are too low for balancing) then the CBUV bit is set and there will be no cell balancing. Cell balance does not start again until the CBMIN value rises above (CBMIN + 1.17mV). When this happens, the ISL94203 clears the CBUV bit.
- If the CELMIN voltage is greater than the CBMAX voltage (all the cell voltages are too high for balancing) then the CBOV bit is set and there will be no cell balancing. Cell balancing does not start

again until the CBMAX value drops below (CBMAX - 117mV). When this happens, the ISL94203 clears the CBOV bit.

- A register in EEPROM (CELLS) identifies the number of cells that are supposed to be present so only the cells present are used for the cell balance operation. Note: This is also used in the cell voltage scan and open-wire detect operation.
- There are no limits to the number of cells that can be balanced at any one time, because the balancing is done external to the device.
- The cell balance block updates at the start of the cell balance ON period to determine if balancing is needed and that the right cells are being balanced. The cells selected at this time will be balanced for the duration of the cell balance period.
- The cell balance is disabled if any external temperature is out of a programmed range set by CBUTS (cell balance under temperature) and CBOTS (cell balance over-temperature).
- The cell balance operation can be disabled by setting the Cell Balance During Charge (CBDC), the Cell Balance During Discharge (CBDD) and the Cell Balance During End-of-Charge (CB\_EOC) bits to zero. See [Table 9 on page 39](#).
- Cell balancing turns off when set to balance in the charge mode and there is no charging current detected (see CB\_EOC exception below).
- Cell balancing turns off when set to balance in the discharge mode and there is no discharge current detected (see CB\_EOC exception below).
- If cell balancing is set to operate during both charge and discharge, then ISL94203 balances while there is charge current or discharge current, but does not balance when no current flow is detected (all other limiting factors continue to apply). See CB\_EOC exception in the following.
- The CB\_EOC bit provides an exception to the cell balance current direction limit. When the CB\_EOC bit is set, balancing occurs while an end of charge condition exists (EOC bit = 1), regardless of current flow. This allows the ISL94203 to “drain” high voltage cells when the charge is complete. This speeds the balancing of the pack, especially when there is a large capacity differential between cells. Once the end of charge condition clears, the cell balance operation returns to normal programming.
- Balance is disabled by asserting the FETSOFF external pin.
- The cell balance outputs are on only while the cell balance on timer is counting down. This is a 12-bit timer. The cell balance outputs are all off while the cell balance off timer is counting down. This is also a 12-bit timer. The timer values are set as in [Table 10](#).

TABLE 9. CELL BALANCE TRUTH TABLE (SEE [Figure 29](#))

CB_EOC BIT	EOC PIN	CBDC	CHING	CBDD	DCHING	ENABLE
0 1	x 1	0	0	0	0	0
0 1	x 1	0	0	0	1	0
0 1	x 1	0	0	1	0	0
0 1	x 1	0	0	1	1	1
0 1	x 1	0	1	0	0	0
0 1	x 1	0	1	0	1	0
0 1	x 1	0	1	1	0	0
0 1	x 1	0	1	1	1	0
0 1	x 1	1	0	0	0	0
0 1	x 1	1	0	0	1	0
0 1	x 1	1	0	1	0	0
0 1	x 1	1	0	1	1	1
0 1	x 1	1	1	0	0	1
0 1	x 1	1	1	0	1	0
0 1	x 1	1	1	1	0	1
0 1	x 1	1	1	1	1	0
1	0	x	x	x	x	1

TABLE 10. CBON AND CBOFF TIMES

SCALE VALUE	TIME (10-BIT VALUE)
00	0 to 1024µs
01	0 to 1024ms
10	0 to 1024s
11	0 to 1024min

## µC Control of Cell Balance FETs

To control the cell balance FETs, the external microcontroller first needs to set the µCCBAL bit to turn off the automatic cell balance operation.

To turn on a cell balance FET, the µC needs to turn on the cell balance output FET using the Cell Balance Control Register 84H. In this register, each bit corresponds to a specific cell balance output.

With the cell balance outputs specified, the microcontroller sets the CBAL\_ON bit. This turns on the cell balance output control circuit.

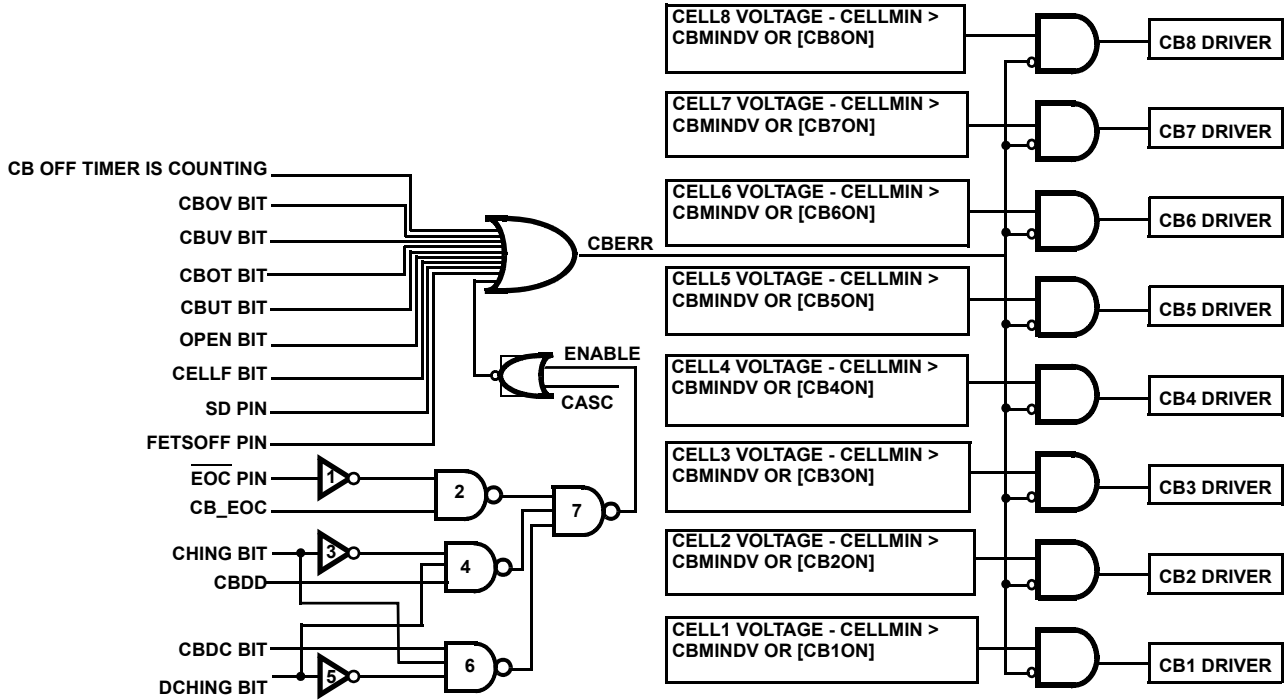

FIGURE 29. CELL BALANCE OPERATION

### Cell Balance FET Drive

The cell balance FETs are driven by a current source or sink of 25µA. The gate voltage on the external FET is set by the gate to source resistor. This resistor should be set such that the gate voltage does not exceed 9V. An external 9V zener diode across the gate to source resistor can help to prevent overvoltage conditions on the cell balance pin.

The cell balance circuit connection is shown in [Figure 30 on page 41](#).

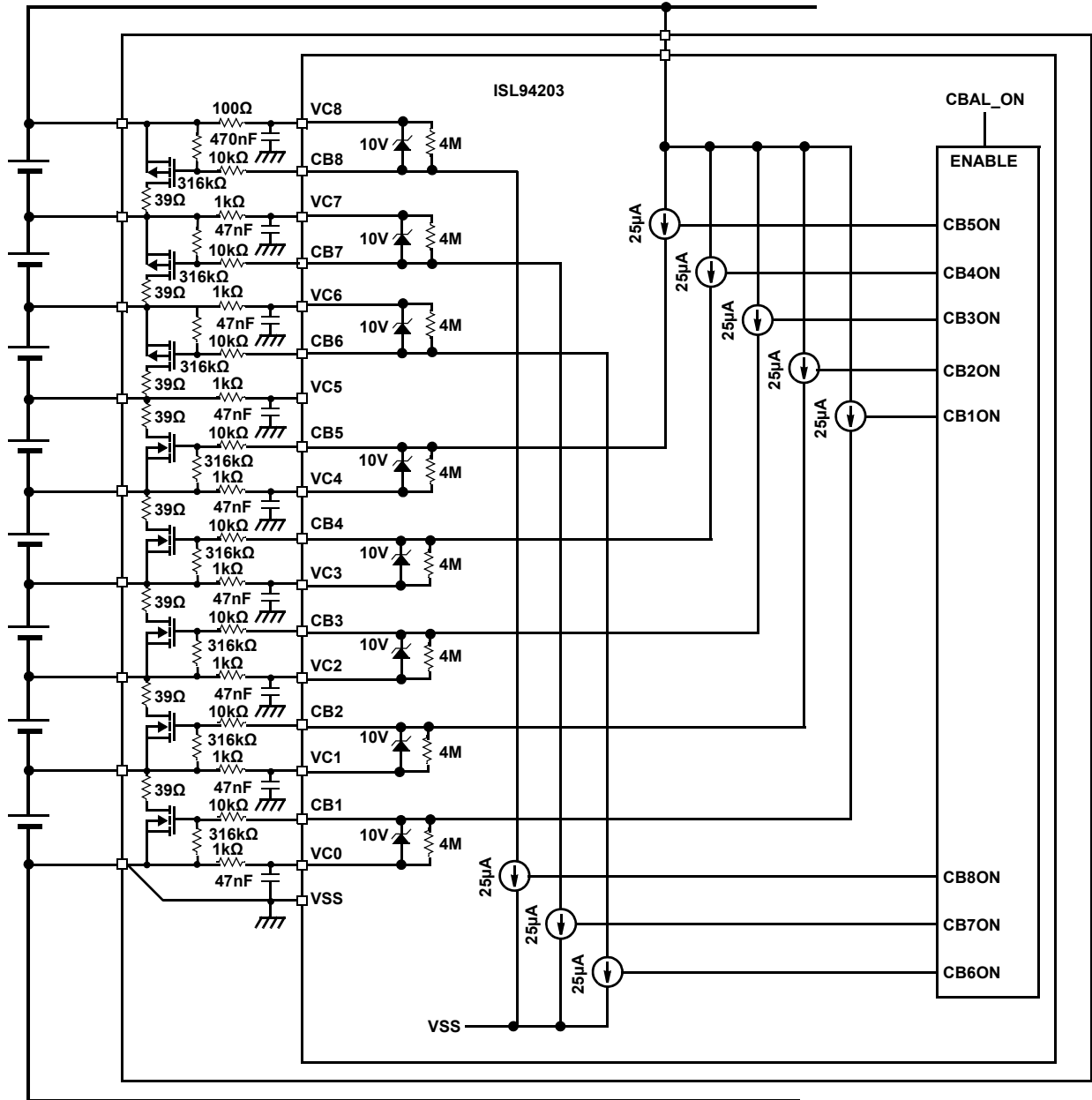

FIGURE 30. CELL BALANCE DRIVE CIRCUITS AND CELL CONNECTION OPTIONS

## Watchdog Timer

The I<sup>2</sup>C watchdog timer prevents an external microcontroller from initiating an action that it cannot undo through the I<sup>2</sup>C port, which can result in poor or unexpected operation of the pack.

The watchdog timer is normally inactive when operating the device in a stand-alone operation. When the pack is expected to have a  $\mu$ C along with the ISL94203, the WDT is activated by setting any of the following bits:

$\mu$ CSCAN,  $\mu$ CCMON,  $\mu$ CLMON,  $\mu$ CCBAL,  $\mu$ CFET, EEEN.

When active (an external  $\mu$ C is assumed to be connected), the absence of I<sup>2</sup>C communications for the watchdog timeout period causes a timeout event. The ISL94203 needs to see a start bit and a valid slave byte to restart the timer.

The watchdog timeout signal turns off the cell balance and power FET outputs, resets the serial interface and pulses the  $\overline{\text{INT}}$  output once per second in an attempt to get the microcontroller to respond. If the  $\overline{\text{INT}}$  is unsuccessful in restarting the communication interface, the part operates normally, except the power FETs and cell balance FETs are forced off. The ISL94203 remains in this condition until I<sup>2</sup>C communications resumes.

When I<sup>2</sup>C communication resumes, the  $\mu$ CSCAN,  $\mu$ CCMON,  $\mu$ CLMON,  $\mu$ CFET and EEEN bits are automatically cleared and the  $\mu$ CCBAL bit remains set. The power FETs and cell balance FETs turn on, if conditions allow.

## Power FET Drive

The ISL94203 drives the power FETs gates with a voltage higher than the supply voltage by using external capacitors as part of a charge pump. The capacitors connect (as shown in [Figure 2 on page 7](#)) and are nominally 4.7nF. The charge pump applies approximately ( $V_{DD} * 2$ ) voltage to the gate, although the voltage is clamped at  $V_{DD} + 16V$ .

The Power FET turn-on times are limited by the capacitance of the power FET and the current supplied by the charge pump. The power FET turn-off times are limited by the capacitance of the power FET and the pull-down current of the ISL94203. The ISL94203 provides a pull-down current for up to 300 $\mu$ s. This should be long enough to discharge any FET capacitance.

[Table 11](#) shows typical turn-on and turn-off times for the ISL94203 under specific conditions.

TABLE 11. POWER FET GATE CONTROL (TYPICAL)

PARAMETER	CONDITIONS	TYPICAL
Power FET Gate Turn-On Current	DFET, CFET, PCFET Charge pump caps = 4.7nF	32kHz 5mA, pulses, 50% duty cycle
Power FET Gate Turn-On Time	10% to 90% of final voltage $V_{DD} = 28V$ ; DFET, CFET = IRF1404 PCFET = FDD8451	160 $\mu$ s 160 $\mu$ s
Power FET Gate Turn-Off Current	CFET, CFET, PCFET	13mA(CFET, PCFET) 15mA (DFET)

TABLE 11. POWER FET GATE CONTROL (TYPICAL)

PARAMETER	CONDITIONS	TYPICAL
Power FET Gate Turn-Off Pulse Width	Pulse duration	300 $\mu$ s
Power FET Gate Fall Time	90% to 10% of final voltage $V_{DD} = 28V$ ; DFET: IRF1404 CFET: IRF1404 PCFET: FDD8451	6 $\mu$ s 6 $\mu$ s 2 $\mu$ s

## General I/Os

There is an open-drain output ( $\overline{\text{SD}}$ ) that is pulled up to RGO (using an external resistor) and indicates if there are any error conditions, such as overvoltage, undervoltage, over-temperature, open input and overcurrent. The output goes active (LOW) when there is any cell or pack failure condition. The output returns HIGH when all error conditions clear.

There is an open-drain output ( $\overline{\text{EOC}}$ ) that is pulled up to RGO (using an external resistor) and indicates that the cells have reached an end of conversion state. The output goes active (LOW) when all cell voltages are above a threshold specified by a 12-bit value in EEPROM. The output returns HIGH, when all cells are below the EOC threshold.

Factory programmable options offer inverse polarity of  $\overline{\text{SD}}$  or  $\overline{\text{EOC}}$ . Please contact [Automotive Marketing](#) if there is interest in either of these options.

The PSD pin goes active high, when any cell voltage reaches the OVLO threshold (OVLO flag). Optionally, PSD also goes high if there is a voltage differential between any two cells that is greater than a specified limit (CELLF flag) or if there is an open-wire condition. This pin can be used for blowing a fuse in the pack or as an interrupt to an external  $\mu$ C.

An input pin (FETSOFF), when pulled high, turns off the power FETs and the cell balance FETs, regardless of any other condition.

## Higher Voltage Microcontrollers

When using a microcontroller powered by 3.3V or 5V, the design can include pull-up resistors to the microcontroller supply on the communication link and the open-drain  $\overline{\text{SD}}$  and  $\overline{\text{EOC}}$  pins (instead of pull-up resistors to RGO.)

The  $\overline{\text{INT}}$  pin is a CMOS output with a maximum voltage of  $RGO+0.5V$ . It is OK to connect this directly to a microcontroller as long as the microcontroller pin does not have a pull up to the 3.3/5V supply. If it does, then a series resistor is recommended.

The FETSOFF input on the ISL94203 is also limited to  $RGO+0.5V$ . This is limited by an input ESD structure that clamps the voltage. The connection from the  $\mu$ C to this pin should include a series resistor to limit any current resulting from the clamp.

An example of this connection is shown in [Figure 31 on page 43](#).

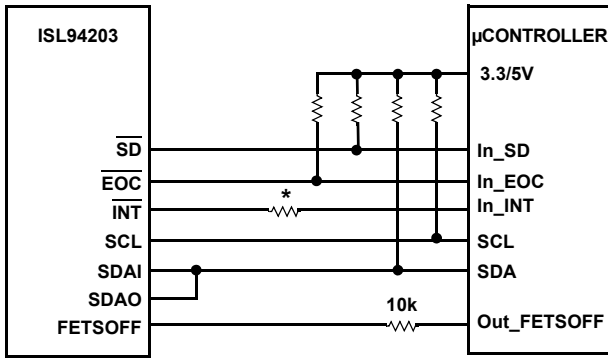

\* Resistor needed only if  $\mu$ C has a pull-up on the In\_INT pin

FIGURE 31. CONNECTION OF HIGHER VOLTAGE MICROCONTROLLER

## Packs with Fewer than 8 Cells

See “Pack Configuration” on page 20 for help when using fewer than 8 cells. This section presents options for minimum number of components. However, when using the ISL94203EVAL1Z evaluation board with fewer than 8 cells, it is not necessary to remove components from the PCB. Simply tie the unused connections together, as shown in Figure 32. This normally requires only a different cable.

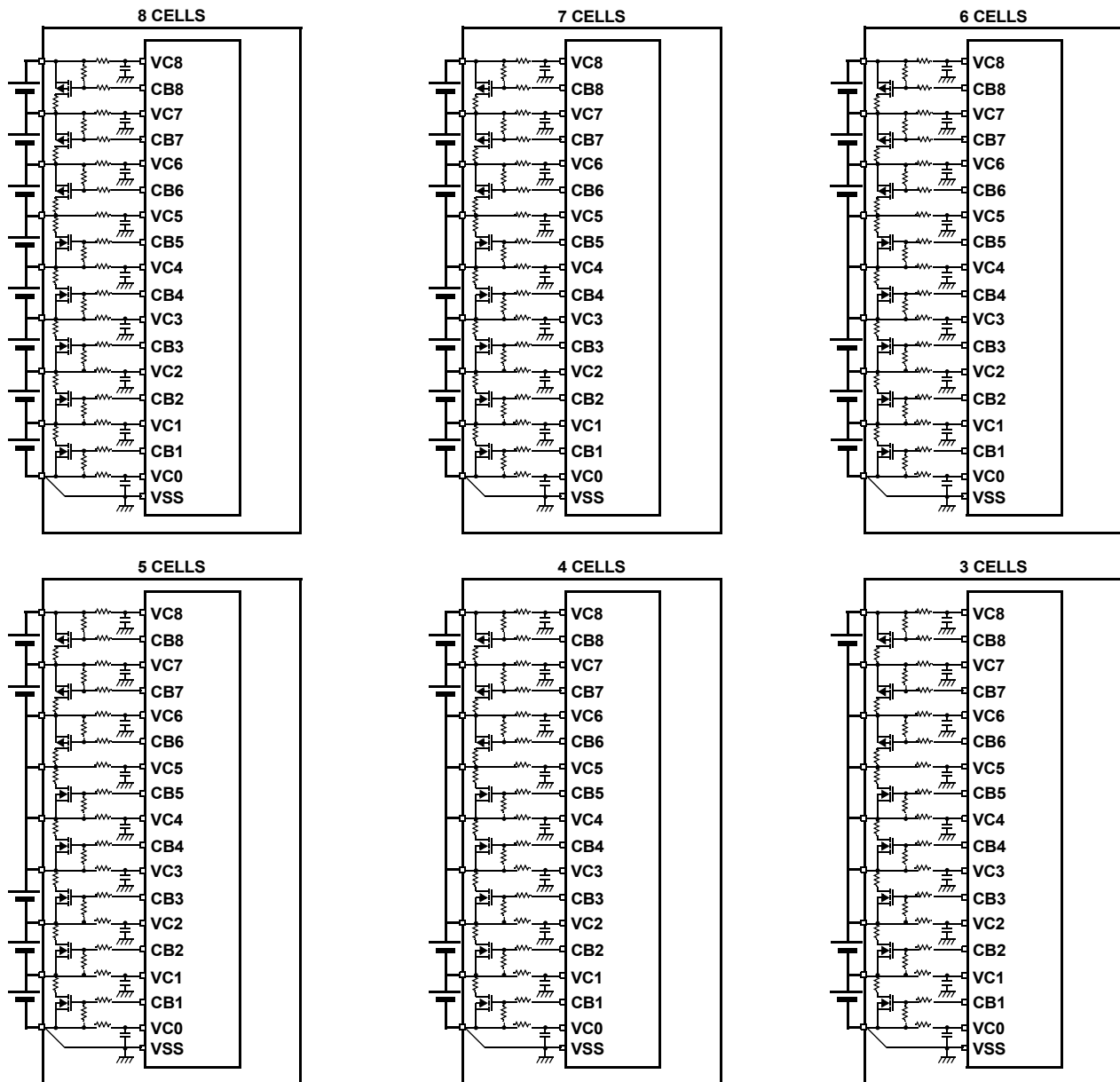

FIGURE 32. BATTERY CONNECTION OPTIONS USING THE ISL94203EVAL1Z BOARD

## PC Board Layout

The AC performance of this circuit depends greatly on the care taken in designing the PC board. The following are recommendations to achieve optimum high performance from your PC board.

- The use of low inductance components, such as chip resistors and chip capacitors, is strongly recommended.
- Minimize signal trace lengths. This is especially true for the CS1, CS2 and VC0-VC8 inputs. Trace inductance and capacitance can easily affect circuit performance. Vias in the signal lines add inductance at high frequency and should be avoided.
- Match channel-to-channel analog I/O trace lengths and layout symmetry. This is especially true for the CS1 and CS2 lines, since their inputs are normally very low voltage.
- Maximize use of AC decoupled PCB layers. All signal I/O lines should be routed over continuous ground planes (i.e. no split planes or ground plane gaps under these lines). Avoid vias in the signal I/O lines.
- VDD bypass and charge pump capacitors should use wide temperature and high frequency dielectric (X7R or better) with capacitors rated at 2X the maximum operating voltage.
- The charge pump and VDD bypass capacitors should be located close to the ISL94203 pins and VDD should have a good ground connection.
- When testing use good quality connectors and cables, matching cable types and keeping cable lengths to a minimum.
- An example PCB layout is shown in [Figure 33](#). This shows placement of the VDD bypass capacitor close to the VDD pin and with a good ground connection. The charge pump capacitors are also close to the IC. The current sense lines are shielded by ground plane as much as possible. The ground plane under the IC is shown as an “island”. The intent of this layout was to minimize voltages induced by EMI on the ground

plane in the vicinity of the IC. This example assumes a 4-layer board with most signals on the inner layers.

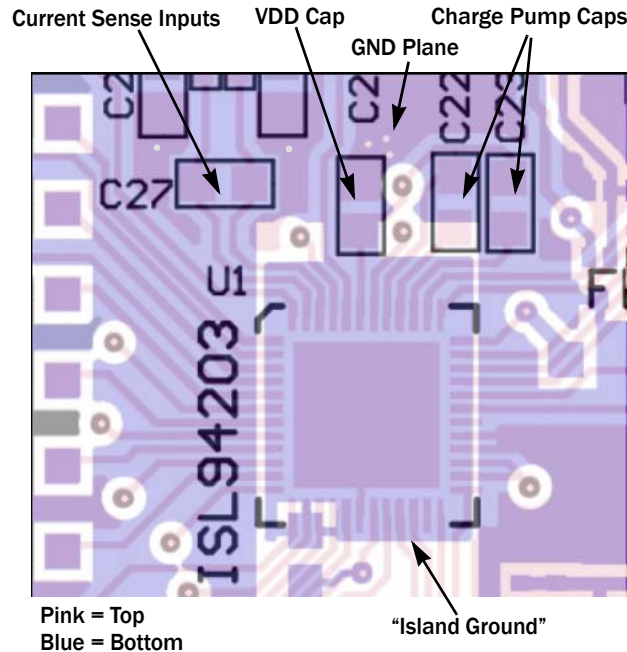

FIGURE 33. EXAMPLE 4-LAYER PCB LAYOUT FOR VDD BYPASS, CHARGE PUMP AND CURRENT SENSE

### QFN Package

The QFN package requires additional PCB layout rules for the thermal pad. The thermal pad is electrically connected to VSS supply through the high resistance IC substrate. The thermal pad provides heat sinking for the IC. In normal operation, the device should generate little heat, so thermal pad design and layout are not too important. However, if the design uses the RGO pin to supply power to external components, then the IC can experience some internal power dissipation. In this case, careful layout of the thermal pad and the use of thermal vias to direct the heat away from the IC is an important consideration. Besides heat dissipation, the thermal pad also provides noise reduction by providing a ground plane under the IC.

### Circuit Diagrams

The [“Block Diagram” on page 7](#) shows a simple application diagram with 8 cells in series and two cells in parallel (8S2P).

## EEPROM

The ISL94203 contains an EEPROM array for storing the device configuration parameters, the device calibration values and some user available registers. Access to the EEPROM is through the I<sup>2</sup>C port of the device. Memory is organized in a memory map as described in [“Registers: Summary \(EEPROM\)” on page 50](#), [“Registers: Summary \(RAM\)” on page 50](#), [“Registers: Detailed \(EEPROM\)” on page 51](#) and [“Registers: Detailed \(RAM\)” on page 58](#).

When the device powers up, the ISL94203 transfers the contents of the configuration EEPROM memory areas to RAM (Note: the user EEPROM has no associated RAM). An external

microcontroller can read the contents of the Configuration RAM or the contents of the EEPROM. Prior to reading the EEPROM, set the EEEN bit to "1". This enables access to the EEPROM area. If EEEN is "0", then a read or write occurs in the shadow RAM area.

The content of the Shadow Ram determines the operation of the device.

Reading from the RAM or EEPROM can be done using a byte or page read. See:

- ["Current Address Read" on page 48](#)
- ["Random Read" on page 48](#)
- ["Sequential Read" on page 48](#)
- ["EEPROM Access" on page 49](#)
- ["Register Protection" on page 49](#)

Writing to the Configuration or User EEPROM must use a Page Write operation. Each Page is four bytes in length and pages begin at address 0.

See:

- ["Page Write" on page 47](#)
- ["Register Protection" on page 49](#)

The EEPROM contains an error detection and correction mechanism. When reading a value from the EEPROM, the device checks the data value for an error.

If there are no errors, then the EEPROM value is valid and the ECC\_USED and ECC\_FAIL bits are set to "0". If there is a 1-bit error, the ISL94203 corrects the error and sets the ECC\_USED bit. This is a valid operation and value read from the EEPROM is correct. During an EEPROM read, if there is an error consisting of two or more bits, the ISL94203 sets the ECC\_FAIL bit (ECC\_USED = 0). This read contains invalid data.

The error correction is also active during the initial power-on recall of the EEPROM values to the shadow RAM. The circuit corrects for any one-bit errors. Two-bit errors are not corrected and the contents of the shadow RAM maintain the previous value.

Internally, the Power-on Recall circuit uses the ECC\_USED and ECC\_FAIL bits to determine there is a proper recall before allowing the device operation to start. However, an external  $\mu\text{C}$  cannot use these bits to detect the validity of the shadow RAM on power-up or determine the use of the error correction mechanism, because the bits automatically reset on the next valid read.

## Serial Interface

- The ISL94203 uses a standard I<sup>2</sup>C interface, except the design separates the SDA input and output (SDAI and SDAO)
- Separate SDAI and SDAO lines can be tied together and operate as a typical I<sup>2</sup>C bus
- Interface speed is 400kHz, maximum
- A separate pin is provided to select the slave address of device.

## Serial Interface Conventions

The device supports a bidirectional bus oriented protocol. The protocol defines any device that sends data onto the bus as a transmitter and the receiving device as the receiver. The device controlling the transfer is called the master and the device being controlled is called the slave. The master always initiates data transfers and provides the clock for both transmit and receive operations. Therefore, the ISL94203 devices operate as slaves in all applications.

When sending or receiving data, the convention is the most significant bit (MSB) is sent first. Therefore, the first address bit sent is Bit 7.

## Clock and Data

Data states on the SDA line can change only while SCL is LOW. SDA state changes during SCL HIGH are reserved for indicating start and stop conditions (see [Figure 34](#)).

## Start Condition

All commands are preceded by the start condition, which is a HIGH-to-LOW transition of SDA when SCL is HIGH. The device continuously monitors the SDA and SCL lines for the start condition and will not respond to any command until this condition has been met (see [Figure 35](#)).

## Stop Condition

All communications must be terminated by a stop condition, which is a LOW-to-HIGH transition of SDA when SCL is HIGH. The stop condition is also used to place the device into the Standby power mode after a read sequence. A stop condition is only issued after the transmitting device has released the bus (see [Figure 35](#)).

## Acknowledge

Acknowledge is a software convention used to indicate successful data transfer. The transmitting device, either master or slave, releases the bus after transmitting eight bits. During the ninth clock cycle, the receiver pulls the SDA line LOW to acknowledge that it received the eight bits of data (see [Figure 36](#)).

The device responds with an acknowledge after recognition of a start condition and the correct slave byte. If a write operation is selected, the device responds with an acknowledge after the receipt of each subsequent eight bits. The device acknowledges all incoming data and address bytes, except for the slave byte when the contents do not match the device's internal slave address.

In the read mode, the device transmits eight bits of data, releases the SDA line, then monitor the line for an acknowledge. If an acknowledge is detected and no stop condition is generated by the master, the device will continue to transmit data. The device terminates further data transmissions if an acknowledge is not detected. The master must then issue a stop condition to return the device to Standby mode and place the device into a known state.

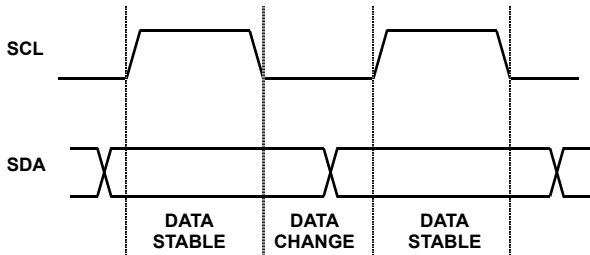

FIGURE 34. VALID DATA CHANGES ON I<sup>2</sup>C BUS

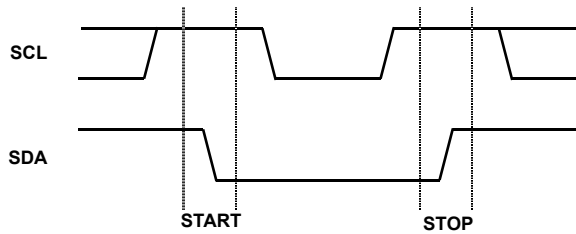

FIGURE 35. I<sup>2</sup>C START AND STOP BITS

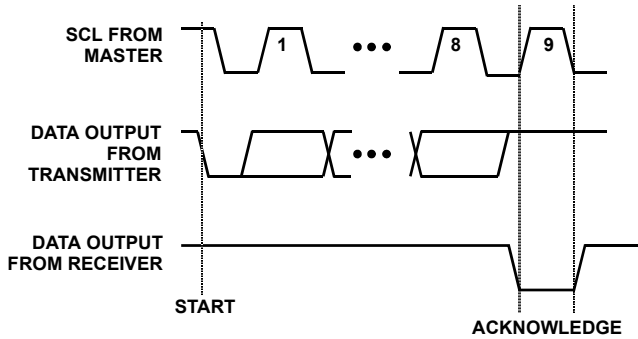

FIGURE 36. ACKNOWLEDGE RESPONSE FROM RECEIVER

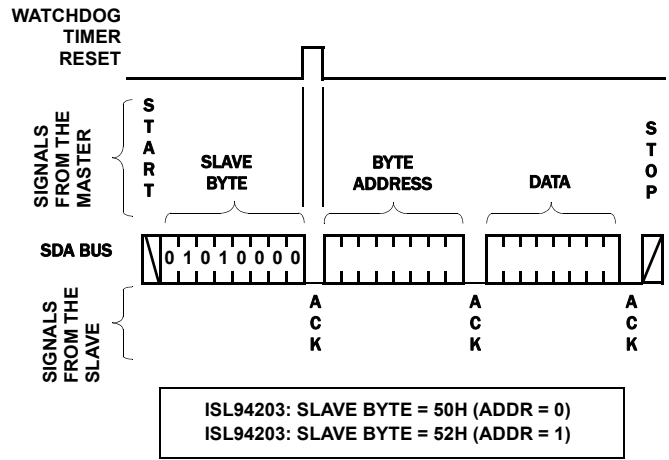

FIGURE 37. BYTE WRITE SEQUENCE

## Write Operations

### BYTE WRITE

For a byte write operation, the device requires the Slave Address Byte and a Word Address Byte. This gives the master access to any one of the words in the array. After receipt of the Word Address Byte, the device responds with an acknowledge and awaits the next eight bits of data. After receiving the 8 bits of the Data Byte, the device again responds with an acknowledge. The master then terminates the transfer by generating a stop condition, at which time the device begins the internal write cycle to the nonvolatile memory. During this internal write cycle, the device inputs are disabled, so the device will not respond to any requests from the master. The SDA output is at high impedance. See [Figure 37 on page 46](#).

A write to a protected block of memory suppresses the acknowledge bit.

When writing to the EEPROM, write to all addresses of a page without an intermediate read operation or use a page write command. Each page is 4 bytes long, starting at address 0.

**PAGE WRITE**

A page write operation is initiated in the same manner as the byte write operation; but instead of terminating the write cycle after the first data byte is transferred, the master can transmit an unlimited number of 8-bit bytes. After the receipt of each byte, the device will respond with an acknowledge and the address is internally incremented by one. The page address remains constant. When the counter reaches the end of the page, it “rolls over” and goes back to ‘0’ on the same page. This means that the master can write 4 bytes to the page starting at any location on that page. If the master begins writing at location 2 and loads 4 bytes, then the first 2 bytes are written to locations 2 and 3 and the last 2 bytes are written to locations 0 and 1. Afterwards, the

address counter would point to location 2 of the page that was just written. If the master supplies more than 4 bytes of data, then new data overwrites the previous data, one byte at a time. See [Figure 38](#).

Do not write to addresses 58H through 7FH or locations higher than address ABH, since these addresses access registers that are reserved. Writing to these locations can result in unexpected device operation.

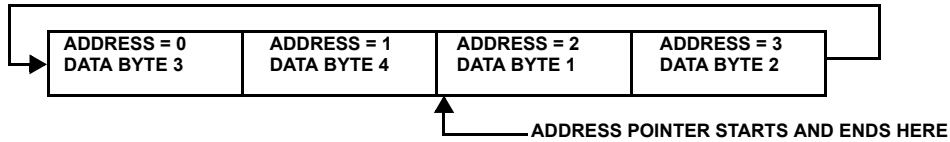

FIGURE 38. WRITING 4 BYTES TO A 4-BYTE PAGE STARTING AT LOCATION 2

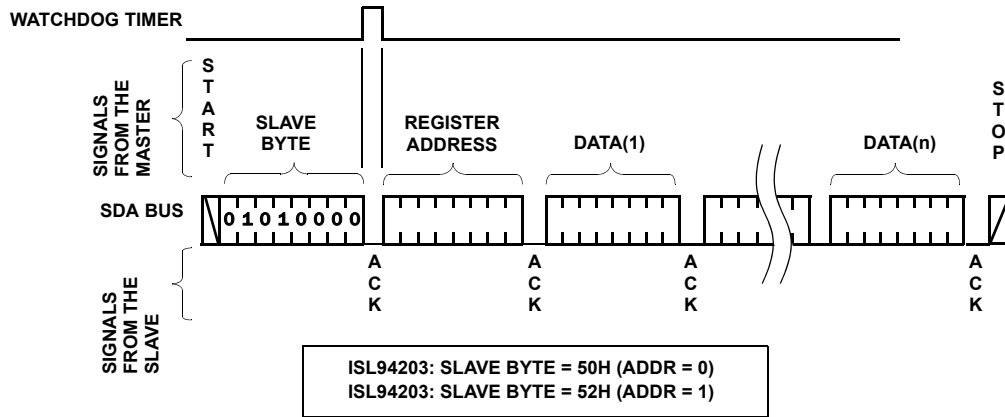

FIGURE 39. PAGE WRITE SEQUENCE

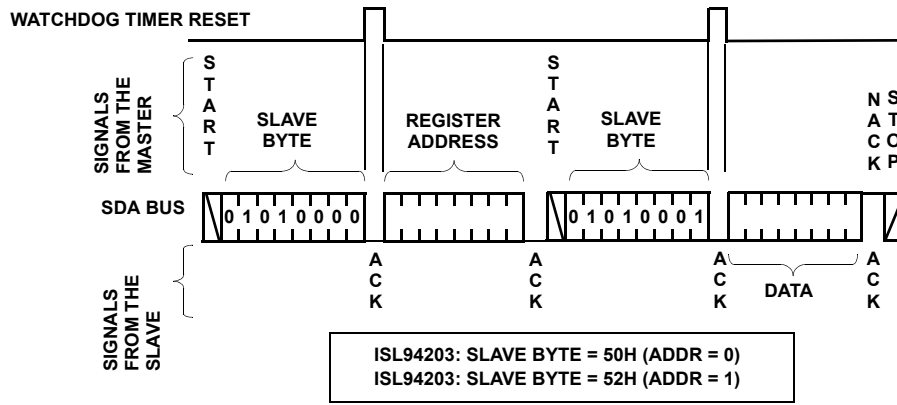

FIGURE 40. RANDOM READ SEQUENCE

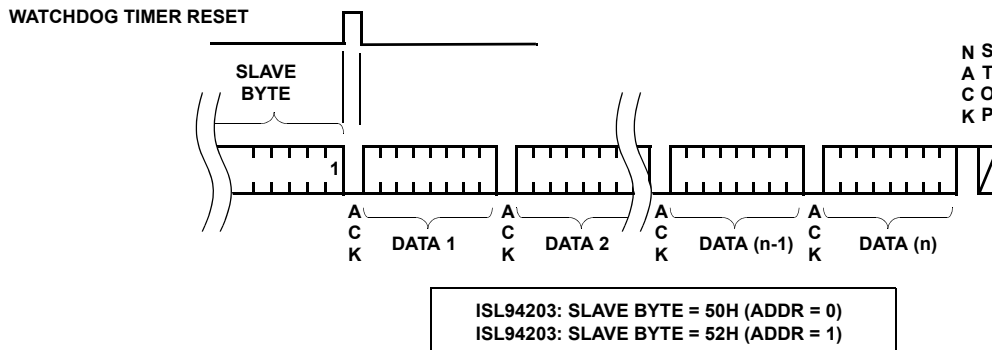

FIGURE 41. SEQUENTIAL READ SEQUENCE

**Read Operations**

Read operations are initiated in the same manner as write operations with the exception that the  $R/\bar{W}$  bit of the Slave Address Byte is set to one. There are three basic read operations: Current Address Reads, Random Reads and Sequential Reads.

**CURRENT ADDRESS READ**

Internally the device contains an address counter that maintains the address of the last word read incremented by one. Therefore, if the last read was to address  $n$ , the next read operation would access data from address  $n+1$ . On power-up, the address of the address counter is undefined, requiring a read or write operation for initialization. See [Figure 42](#).

Upon receipt of the Slave Address Byte with the  $R/\bar{W}$  bit set to one, the device issues an acknowledge and then transmits the eight bits of the Data Byte. The master terminates the read operation when it does not respond with an acknowledge during the ninth clock and then issues a stop condition.

It should be noted that the ninth clock cycle of the read operation is not a “don’t care.” To terminate a read operation, the master must either issue a stop condition during the ninth cycle or hold SDA HIGH during the ninth clock cycle and then issue a stop condition.

**RANDOM READ**

Random read operation allows the master to access any memory location in the array. Prior to issuing the Slave Address Byte with

the  $R/\bar{W}$  bit set to one, the master must first perform a “dummy” write operation. The master issues the start condition and the Slave Address Byte, receives an acknowledge, then issues the Word Address Bytes. After acknowledging receipts of the Word Address Bytes, the master immediately issues another start condition and the Slave Address Byte with the  $R/\bar{W}$  bit set to one. This is followed by an acknowledge from the device and then by the eight bit word. The master terminates the read operation by not responding with an acknowledge and then issuing a stop condition (see [Figure 40](#)).

**SEQUENTIAL READ**

Sequential reads can be initiated as either a current address read or random address read. The first Data Byte is transmitted as with the other modes; however, the master now responds with an acknowledge, indicating it requires additional data. The device continues to output data for each acknowledge received. The master terminates the read operation by not responding with an acknowledge and then issuing a stop condition.

The data output is sequential, with the data from address  $n$  followed by the data from address  $n + 1$ . The address counter for read operations increments through all page and column addresses, allowing the entire memory contents to be serially read during one operation. At the end of the address space the counter “rolls over” to address 0000H and the device continues to output data for each acknowledge received. See [Figure 41](#) for the acknowledge and data transfer sequence.

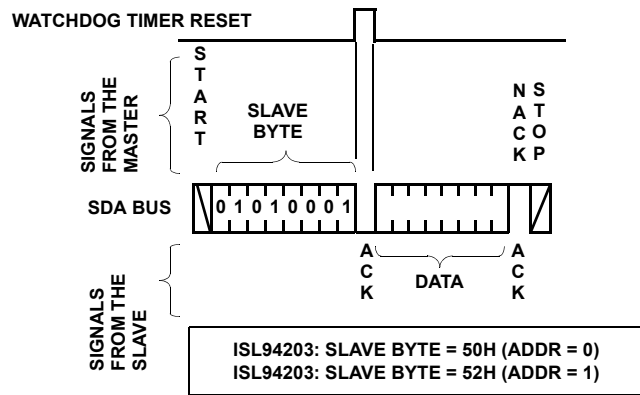

FIGURE 42. CURRENT ADDRESS READ SEQUENCE

## EEPROM ACCESS

The user is advised not to use page transfers when reading or writing to EEPROM. Only single byte I<sup>2</sup>C transactions should be used. In addition, “Write” transactions should be separated with a 30ms delay to enable each byte write operation to complete.

## EEPROM READ

The ISL94203 has a special requirement when reading the EEPROM. An EEPROM read operation from the first byte of a four byte page (locations 0H, 4H, 8H, etc.) initiates a recall of the EEPROM page. This recall takes more than 200 $\mu$ s, so the first byte may not be ready in time for a standard I<sup>2</sup>C response. It is necessary to read this first byte of every page two times.

## EEPROM WRITE

The ISL94203 also has a special requirement when writing the EEPROM. An EEPROM write operation to the first byte of a four byte page (locations 0H, 4H, 8H, etc.) initiates a recall of the EEPROM page. This recall takes more than 200 $\mu$ s, so the first byte may not be ready in time for a standard I<sup>2</sup>C response. It is necessary to write this first byte of every page two times. These “duplicate” writes should be separated with a 30ms delay and followed with a 30ms delay. Again, only single byte transactions should be used with a 30ms delay between each write operation.

## Synchronizing Microcontroller Operations with Internal Scan

Internal scans occur every 32ms in Normal mode, 256ms in Idle mode and 512ms in Doze mode. The internal scan normally takes about 1.3ms, with every fourth scan taking about 1.7ms. While the percentage of time taken by the scan is small, it is long

enough that random communications from the microcontroller can coincide with the internal scan. When the two scans happen at the same time, errors can occur in the recorded values.

To avoid errors in the recorded values, the goal is to synchronize external I<sup>2</sup>C transactions so that they only occur during the device’s Low Power State (see [Figure 23 on page 31](#).) To assist in the synchronization, the microcontroller can use the INT\_SCAN bit. This bit is “0” during the internal scan and “1” during the “Low Power State”.

The microcontroller software should look for the INT\_SCAN bit to go from a “0” to a “1” to allow the maximum time to complete read or write operations. This insures that the results reported to the  $\mu$ C are from a single scan and changes made do not interfere with state machine detection and timing.

## Register Protection

The entire EEPROM memory is write protected on initial power-up and during normal operation. An enable byte allows writing to various areas of the memory array.

The enable byte is encoded, so that a value of ‘0’ in the EEPROM Enable register (89H) enables access to the shadow memory (RAM), a value of ‘1’ allows access to the EEPROM.

**After a read or write of the EEPROM, the microcontroller should reset the EEPROM Enable register value back to zero to prevent inadvertent writes to the EEPROM and to turn off the EEPROM block to reduce current consumption.** If the microcontroller fails to reset the EEPROM bit and communications to the chip stops, then the Watchdog timer will reset the EEPROM select bit.

## Registers: Summary (EEPROM)

TABLE 12. EEPROM REGISTER SUMMARY

EEPROM (CONFIGURED AS 32 4-BYTE PAGES)							
PAGE	ADDR	0x	1x	2x	3x	4x	5x
0	0	Overvoltage Level	Overvoltage Delay Timer	Minimum CB Delta	Charge Over-Temperature Level	Internal Over-Temperature Level	User EEPROM
	1						
	2	Overvoltage recovery	Undervoltage Delay Timer	Maximum CB Delta	Charge Over-Temp Recovery	Internal Over-Temperature Recovery	
	3						
1	4	Undervoltage Level	Open Wire Timing	Cell Balance On time	Charge Under-Temperature Level	Sleep Voltage	
	5						
	6	Undervoltage Recovery	Discharge Overcurrent Timeout Settings, Discharge Setting	Cell Balance Off Time	Charge Under-Temperature Recovery	Sleep Delay Timer/ Watchdog Timer	
	7						
2	8	OVLO Threshold	Charge overcurrent Timeout Settings, Charge overcurrent Setting	Minimum CB Temperature Level	Discharge Over-Temperature Level	Sleep Mode Timer	
	9					CELLS Config	
	A	UVLO Threshold	Short-Circuit Timeout Settings/ Recovery Settings, Short-Circuit Setting	Minimum CB Temperature Recovery	Discharge Over-Temperature Recovery	Features 1	
	B					Features 2	
3	C	EOC Voltage Level	Minimum CB Volts	Maximum CB Temperature Level	Discharge Under-Temperature Level	Reserved	
	D						
	E	Low Voltage Charge Level	Maximum CB Volts	Maximum CB Temperature Recovery	Discharge Under-Temperature Recovery		
	F						

## Registers: Summary (RAM)

TABLE 13. RAM REGISTER SUMMARY

RAM				
PAGE	ADDR	8x	9x	Ax
0	0	Status1	CELL1 Voltage	iT Voltage
	1	Status2		
	2	Status3	CELL2 Voltage	xT1 Voltage
	3	Status4		
1	4	Cell Balance	CELL3 Voltage	xT2 Voltage
	5	Analog Out		
	6	FET Cntl/Override Control Bits	CELL4 Voltage	VBATT/16 Voltage
	7	Override Control Bits		
2	8	Force Ops	CELL5 Voltage	VRGO/2 Voltage
	9	EE Write Enable		
	A	CELLMIN Voltage	CELL6 Voltage	14-bit ADC Voltage
	B			

TABLE 13. RAM REGISTER SUMMARY (Continued)

RAM				
PAGE	ADDR	8x	9x	Ax
3	C	CELLMAX Voltage	CELL7 Voltage	Reserved
	D			
	E	ISense Voltage	CELL8 Voltage	
	F			

## Registers: Detailed (EEPROM)

TABLE 14. EEPROM REGISTER DETAIL

BIT/ ADDR	F 7	E 6	D 5	C 4	B 3	A 2	9 1	8 0	7	6	5	4	3	2	1	0
00 01	<b>Overvoltage Threshold</b> Default (Hex): 1E2A (V): 4.25 If any cell voltage is above this threshold voltage for an overvoltage delay time, the charge FET is turned off.															
<b>Charge Detect Pulse Width</b> These bits set the duration of the charger monitor pulse width.				OVLB	OVL9	OVL8	OVL7	OVL6	OVL5	OVL4	OVL3	OVL2	OVL1	OVL0		
CPW3 CPW2 CPW1 CPW0				$\text{Threshold} = \frac{\text{HEXvalue}_{10} \times 1.8 \times 8}{4095 \times 3}$												
0000 = 0ms to 1111 = 15ms; Default = 1ms																
02 03	<b>Overvoltage Recovery</b> Default (Hex): 0DD4 (V): 4.15 If all cells fall below this overvoltage recovery level, the charge FET is turned on.															
Reserved				OVRB	OVR9	OVR8	OVR7	OVR6	OVR5	OVR4	OVR3	OVR2	OVR1	OVR0		
04 05	<b>Undervoltage Threshold</b> Default (Hex): 18FF (V): 2.7 If any cell voltage is below this threshold voltage for an undervoltage delay time, the discharge FET is turned off.															
<b>Load Detect Pulse Width</b> These bits set the duration of the charger monitor pulse width.				UVLB	UVL9	UVL8	UVL7	UVL6	UVL5	UVL4	UVL3	UVL2	UVL1	UVL0		
LPW3 LPW2 LPW1 LPW0				$\text{Threshold} = \frac{\text{HEXvalue}_{10} \times 1.8 \times 8}{4095 \times 3}$												
0000 = 0 ms to 1111 = 15ms; Default = 1ms																
06 07	<b>Undervoltage Recovery</b> Default (Hex): 09FF (V): 3.0 If all cells rise above this overvoltage recovery level (and there is no load), the discharge FET is turned on.															
Reserved				UVRB	UVR9	UVR8	UVR7	UVR6	UVR5	UVR4	UVR3	UVR2	UVR1	UVR0		
08 09	<b>Overvoltage Lockout Threshold</b> Default (Hex): 0E7F (V): 4.35 If any cell voltage is above this threshold for five successive scans, then the device is in an overvoltage lockout condition. In this condition, the Charge FET is turned off, the cell balance FETs are turned off, the OVLO bit is set and the PSD output is set to active.															
Reserved				OVLOB	OVLO9	OVLO8	OVLO7	OVLO6	OVLO5	OVLO4	OVLO3	OVLO2	OVLO1	OVLO0		
0A 0B	<b>Undervoltage Lockout Threshold</b> Default (Hex): 0600 (V): 1.8 If any cell voltage is below this threshold for five successive scans, then the device is in an undervoltage lockout condition. In this condition, the Discharge FET is turned off and the UVLO bit is set. The device also powers down (unless overridden).															
Reserved				UVLOB	UVLO9	UVLO8	UVLO7	UVLO6	UVLO5	UVLO4	UVLO3	UVLO2	UVLO1	UVLO0		

**TABLE 14. EEPROM REGISTER DETAIL (Continued)**

BIT/ ADDR	F 7	E 6	D 5	C 4	B 3	A 2	9 1	8 0	7	6	5	4	3	2	1	0	
0C 0D	<b>End-of-Charge (EOC) Threshold</b> If any cell exceeds this level, then the EOC output and the EOC bit are set.															Default (Hex): 0DFF	(V): 4.2
	Reserved				EOCB	EOCA	EOC9	EOC8	EOC7	EOC6	EOC5	EOC4	EOC3	EOC2	EOC1	EOC0	
0E 0F	<b>Low Voltage Charge Level</b> If the voltage on any cell is less than this level, then the PCFET output turns on instead of the PC output. To disable this function, set the value to zero or set the PCFETE bit to 0.															Default (Hex): 07AA	(V): 2.3
	Reserved				LVCHB	LVCHA	LVCH9	LVCH8	LVCH7	LVCH6	LVCH5	LVCH4	LVCH3	LVCH2	LVCH1	LVCH0	
10 11	<b>Overvoltage Delay Time Out</b> This value sets the time that is required for any cell to be above the overvoltage threshold before an overvoltage condition is detected.															Default (Hex): 0801	(s): 1
	Reserved				OVRTB	OVRTA	OVRT9	OVRT8	OVRT7	OVRT6	OVRT5	OVRT4	OVRT3	OVRT2	OVRT1	OVRT0	
					00 = $\mu$ s 01 = ms 10 = s 11 = min	0 to 1024											
12 13	<b>Undervoltage Delay Time Out</b> This value sets the time that is required for any cell to be below the undervoltage threshold before an undervoltage condition is detected.															Default (Hex): 0801	(s): 1
	Reserved				UVDTB	UVDTA	UVDT9	UVDT8	UVDT7	UVDT6	UVDT5	UVDT4	UVDT3	UVDT2	UVDT1	UVDT0	
					00 = $\mu$ s 01 = ms 10 = s 11 = min	0 to 1024											
14 15	<b>Open-Wire Timing (OWT)</b> This value sets the width of the open-wire test pulse for each cell input.															Default (Hex): 0214	(ms): 20
	Reserved						OWT9	OWT8	OWT7	OWT6	OWT5	OWT4	OWT3	OWT2	OWT1	OWT0	
							0 = $\mu$ s 1 = ms	0 to 512									
16 17	<b>Discharge Overcurrent Time Out/Threshold Time Out</b> A discharge overcurrent needs to remain for this time period prior to entering a discharge overcurrent condition. This is an 12-bit value: Lower 10 bits sets the time. Upper bits sets the time base.															Default (Hex): 44A0	(ms): 160 (mV): 32
	<b>Threshold</b> This value sets the voltage across current sense resistor that creates a discharge overcurrent condition.				OCDTB	OCDTA	OCDT9	OCDT8	OCDT7	OCDT6	OCDT5	OCDT4	OCDT3	OCDT2	OCDT1	OCDT0	
	000 = 4mV 001 = 8mV 010 = 16mV 011 = 24mV 100 = 32mV 101 = 48mV 110 = 64mV 111 = 96mV				00 = $\mu$ s 01 = ms 10 = s 11 = min		0 to 1024										

TABLE 14. EEPROM REGISTER DETAIL (Continued)

BIT/ ADDR	F 7	E 6	D 5	C 4	B 3	A 2	9 1	8 0	7	6	5	4	3	2	1	0
18 19	Charge Overcurrent Time Out/Threshold <b>Time Out</b> A charge overcurrent needs to remain for this time period prior to entering a charge overcurrent condition. This is an 12-bit value: Lower 10 bits sets the time. Upper bits set the time base.										Default (Hex): 44A0		(ms): 160	(mV): 8		
<b>Threshold</b> This value sets the voltage across current sense resistor that creates a charge overcurrent condition																
	OCC2	OCC1	OCC0	OCCTB	OCCTA	OCCT9	OCCT8	OCCT7	OCCT6	OCCT5	OCCT4	OCCT3	OCCT2	OCCT1	OCCT0	
	000 = 1mV 001 = 2mV 010 = 4mV 011 = 6mV 100 = 8mV 101 = 12mV 110 = 16mV 111 = 24mV			00 = $\mu$ s 01 = ms 10 = s 11 = min		0 to 1024										
1A 1B	Discharge Short-Circuit Time Out/Threshold <b>Time Out</b> A short-circuit current needs to remain for this time period prior to entering a short-circuit condition. This is an 12 bit value: Lower 10 bits sets the time. Upper bits set the time base										Default (Hex): 60C8		( $\mu$ s): 200	(mV): 128		
<b>Threshold</b> This value sets the voltage across current sense resistor that creates a short-circuit condition																
	SCD2	SCD1	SCD0	SCTB	SCTA	SCT9	SCT8	SCT7	SCT6	SCT5	SCT4	SCT3	SCT2	SCT1	SCT0	
	000 = 16mV 001 = 24mV 010 = 32mV 011 = 48mV 100 = 64mV 101 = 96mV 110 = 128mV 111 = 256mV			00 = $\mu$ s 01 = ms 10 = s 11 = min		0 to 1024										
1C 1D	<b>Cell Balance Minimum Voltage (CBMIN)</b> If all cell voltages are less than this voltage, then cell balance stops.										Default (Hex): 0A55		(V): 3.1			
	Reserved			CBVLB	CBVLA	CBVL9	CBVL8	CBVL7	CBVL6	CBVL5	CBVL4	CBVL3	CBVL2	CBVL1	CBVL0	
1E 1F	<b>Cell Balance Maximum Voltage (CBMAX)</b> If all cell voltages are greater than this voltage, then cell balance stops.										Default (Hex): 0D70		(V): 4.0			
	Reserved			CBVUB	CBVUA	CBVU9	CBVU8	CBVU7	CBVU6	CBVU5	CBVU4	CBVU3	CBVU2	CBVU1	CBVU0	
20 21	<b>Cell Balance Minimum Differential Voltage (CBMINDV)</b> If the difference between the voltage on CELLN and the lowest voltage cell is less than this voltage, then cell balance for CELLN stops.										Default (Hex): 0010		(mV): 20			
	Reserved			CBDLB	CBDLA	CBDL9	CBDL8	CBDL7	CBDL6	CBDL5	CBDL4	CBDL3	CBDL2	CBDL1	CBDL0	
22 23	<b>Cell Balance Maximum Differential Voltage (CBMAXDV)</b> If the difference between the voltage on CELLN and the lowest voltage cell is greater than this voltage, then cell balance for CELLN stops and the CELLF flag is set.										Default (Hex): 01AB		(mV): 500			
	Reserved			CBDUB	CBDUA	CBDU9	CBDU8	CBDU7	CBDU6	CBDU5	CBDU4	CBDU3	CBDU2	CBDU1	CBDU0	

TABLE 14. EEPROM REGISTER DETAIL (Continued)

BIT/ ADDR	F 7	E 6	D 5	C 4	B 3	A 2	9 1	8 0	7	6	5	4	3	2	1	0
24 25	<b>Cell Balance On Time (CBON)</b> Default (Hex): 0802 (s): 2															
Cell balance is on for this set amount of time, unless another condition indicates that there should be no cell balance. This is a 12-bit value: Lower 10 bits sets the time. Upper 2 bits set the time base.																
Reserved				CBONT B	CBONT A	CBONT 9	CBONT 8	CBONT 7	CBONT 6	CBONT 5	CBONT 4	CBONT 3	CBONT 2	CBONT 1	CBONT 0	
				00 = $\mu$ s 01 = ms 10 = s 11 = min		0 to 1024										
26 27	<b>Cell Balance Off Time (CBOFF)</b> Default (Hex): 0802 (s): 2															
Cell balance is off for the set amount of time. This is a 12-bit value: Lower 10 bits sets the time. Upper 2 bits set the time base.																
Reserved				CBOFT B	CBOFT A	CBOFT 9	CBOFT 8	CBOFT 7	CBOFT 6	CBOFT 5	CBOFT 4	CBOFT 3	CBOFT 2	CBOFT 1	CBOFT 0	
				00 = $\mu$ s 01 = ms 10 = s 11 = min		0 to 1024										
28 29	<b>Cell Balance Minimum Temperature Limit (CBUTS)</b> Default (Hex): 0BF2 (V): 1.344 (°C): -10															
If the external 1 temperature or the external 2 temperature (XT2M = 0) is greater than this voltage, then cell balance stops. The voltage is based on recommended external components (see <a href="#">Figure 27 on page 35</a> ).																
Reserved				CBUTS B	CBUTS A	CBUTS 9	CBUTS 8	CBUTS 7	CBUTS 6	CBUTS 5	CBUTS 4	CBUTS 3	CBUTS 2	CBUTS 1	CBUTS 0	
2A 2B	<b>Cell Balance Minimum Temperature Recovery Level (CBUTR)</b> Default (Hex): 0A93 (V): 1.19 (°C): +5															
If the external 1 temperature and the external 2 temperature (XT2M = 0) all recover and fall below this voltage, then cell balance can resume (all other conditions OK). The voltage is based on recommended external components (see <a href="#">Figure 27 on page 35</a> ).																
Reserved				CBUTR B	CBUTR A	CBUTR 9	CBUTR 8	CBUTR 7	CBUTR 6	CBUTR 5	CBUTR 4	CBUTR 3	CBUTR 2	CBUTR 1	CBUTR 0	
2C 2D	<b>Cell Balance Maximum Temperature Limit (CBOTS)</b> Default (Hex): 04B6 (V): 0.530 (°C): +55															
If the external 1 temperature or the external 2 temperature (XT2M = 0) is less than this voltage, then cell balance stops. The voltage is based on recommended external components (see <a href="#">Figure 27 on page 35</a> ).																
Reserved				CBOTS B	CBOTS A	CBOTS 9	CBOTS 8	CBOTS 7	CBOTS 6	CBOTS 5	CBOTS 4	CBOTS 3	CBOTS 2	CBOTS 1	CBOTS 0	
2E 2F	<b>Cell Balance Maximum Temperature Recovery Level (CBOTR)</b> Default (Hex): 053E (V): 0.590 (°C): +50															
If the external 1 temperature and the external 2 temperature (XT2M = 0) all recover and rise above this voltage, then cell balance can resume (all other conditions OK). The voltage is based on recommended external components (see <a href="#">Figure 27 on page 35</a> ).																
Reserved				CBOTR B	CBOTR A	CBOTR 9	CBOTR 8	CBOTR 7	CBOTR 6	CBOTR 5	CBOTR 4	CBOTR 3	CBOTR 2	CBOTR 1	CBOTR 0	
For All Temperature Limits, TGain bit = 0, Temperature Gain = 2																
30 31	<b>Charge Over-Temperature Voltage</b> Default (Hex): 04B6 (mV): 0.530 (°C): +55															
If external 1 temperature or the external 2 temperature is less than this voltage, then the charge FET is turned off and the COT bit is set. The voltage is based on recommended external components (see <a href="#">Figure 27 on page 35</a> ).																
Reserved				COTSB	COTSA	COTS9	COTS8	COTS7	COTS6	COTS5	COTS4	COTS3	COTS2	COTS1	COTS0	

TABLE 14. EEPROM REGISTER DETAIL (Continued)

BIT/ ADDR	F 7	E 6	D 5	C 4	B 3	A 2	9 1	8 0	7	6	5	4	3	2	1	0
32 33	<b>Charge Over-Temperature Recovery Voltage</b> If external 1 temperature or the external 2 temperature rise above this setting, then the charge FET is turned on and the COT bit is reset (unless overrides are in place). The voltage is based on recommended external components (see <a href="#">Figure 27 on page 35</a> ).										Default (Hex): 053E		(mV): 0.590 (°C): +50			
	Reserved				COTRB	COTRA	COTR9	COTR8	COTR7	COTR6	COTR5	COTR4	COTR3	COTR2	COTR1	COTR0
34 35	<b>Charge Under-Temperature Voltage</b> If external 1 temperature or the external 2 temperature is greater than this voltage, then the charge FET is turned off and the CUT bit is set. The voltage is based on recommended external components (see <a href="#">Figure 27 on page 35</a> ).										Default (Hex): 0BF2		(mV): 1.344 (°C): -10			
	Reserved				CUTSB	CUTSA	CUTS9	CUTS8	CUTS7	CUTS6	CUTS5	CUTS4	CUTS3	CUTS2	CUTS1	CUTS0
36 37	<b>Charge Under-Temperature Recovery Voltage</b> If external 1 temperature or the external 2 temperature fall below this setting, then the charge FET is turned on and the CUT bit is reset (unless overrides are in place). The voltage is based on recommended external components (see <a href="#">Figure 27 on page 35</a> ).										Default (Hex): 0A93		(mV): 1.190 (°C): +5			
	Reserved				CUTRB	CUTRA	CUTR9	CUTR8	CUTR7	CUTR6	CUTR5	CUTR4	CUTR3	CUTR2	CUTR1	CUTR0
38 39	<b>Discharge Over-Temperature Voltage</b> If external 1 temperature or the external 2 temperature is less than this voltage, then the discharge FET is turned off and the DOT bit is set. The voltage is based on recommended external components (see <a href="#">Figure 27 on page 35</a> ).										Default (Hex): 4B6		(mV): 0.530 (°C): +55			
	Reserved				DOTSB	DOTSA	DOTS9	DOTS8	DOTS7	DOTS6	DOTS5	DOTS4	DOTS3	DOTS2	DOTS1	DOTS0
3A 3B	<b>Discharge Over-Temperature Recovery Voltage</b> If external 1 temperature or the external 2 temperature rise above this setting, then the discharge FET is turned on and the DOT bit is reset (unless overrides are in place). The voltage is based on recommended external components (see <a href="#">Figure 27 on page 35</a> ).										Default (Hex): 053E		(mV): 0.590 (°C): +50			
	Reserved				DOTRB	DOTRA	DOTR9	DOTR8	DOTR7	DOTR6	DOTR5	DOTR4	DOTR3	DOTR2	DOTR1	DOTR0
3C 3D	<b>Discharge Under-Temperature Voltage</b> If external 1 temperature or the external 2 temperature is greater than this voltage, then the discharge FET is turned off and the DUT bit is set. The voltage is based on recommended external components (see <a href="#">Figure 27 on page 35</a> ).										Default (Hex): 0BF2		(mV): 1.344 (°C): -10			
	Reserved				DUTSB	DUTSA	DUTS9	DUTS8	DUTS7	DUTS6	DUTS5	DUTS4	DUTS3	DUTS2	DUTS1	DUTS0
3E 3F	<b>Discharge Under-Temperature Recovery Voltage</b> If external 1 temperature or the external 2 temperature fall below this setting, then the discharge FET is turned on and the DUT bit is reset (unless overrides are in place). The voltage is based on recommended external components (see <a href="#">Figure 27 on page 35</a> ).										Default (Hex): 0A93		(mV): 1.190 (°C): +5			
	Reserved				DUTRB	DUTRA	DUTR9	DUTR8	DUTR7	DUTR6	DUTR5	DUTR4	DUTR3	DUTR2	DUTR1	DUTR0
40 41	<b>Internal Over-Temperature Voltage</b> If the internal temperature is greater than this voltage, then all FETs are turned off and the IOT bit is set.										Default (Hex): 67CH		(mV): 0.73 (°C): +115			
	Reserved				IOTS B	IOTS A	IOTS 9	IOTS 8	IOTS 7	IOTS 6	IOTS 5	IOTS 4	IOTS 3	IOTS 2	IOTS 1	IOTS 0
42 43	<b>Internal Over-Temperature Recovery Voltage</b> When the internal temperature voltage drops below this level, then the FETs can be turned on again and the IOT bit is reset on the next $\mu$ C read.										Default (Hex): 621H		(mV): 0.69 (°C): +95			
	Reserved				IOTR B	IOTR A	IOTR 9	IOTR 8	IOTR 7	IOTR 6	IOTR 5	IOTR 4	IOTR 3	IOTR 2	IOTR 1	IOTR 0

**TABLE 14. EEPROM REGISTER DETAIL (Continued)**

BIT/ ADDR	F 7	E 6	D 5	C 4	B 3	A 2	9 1	8 0	7	6	5	4	3	2	1	0	
44	<b>Sleep Level Voltage</b>															Default (Hex): 06AA	(V): 2.0
45	If any cell voltage is below this threshold voltage for a sleep delay time, the device goes into the Sleep mode.																
	Reserved				SLLB	SLLA	SLL9	SLL8	SLL7	SLL6	SLL5	SLL4	SLL3	SLL2	SLL1	SLL0	
46	<b>Sleep Delay Timer/Watchdog Timer</b>															Default (Hex): FCOF	Sleep (s) 1
47	<b>Sleep Delay</b>															WDT (s) 31	
	This value sets the time that is required for any cell to be below the sleep voltage threshold before the device enters the Sleep mode. Lower 10 bits sets the time. Upper 1 bit sets the time base.																
	<b>Watchdog Timer (WDT)</b>																
	Time allowed the microcontroller between I <sup>2</sup> C slave byte writes to the ISL94203 after setting any override bit.																
	WDT4	WDT3	WDT2	WDT1	WDT0	SLTA	SLT9	SLT8	SLT7	SLT6	SLT5	SLT4	SLT3	SLT2	SLT1	SLT0	
	0 to 31 seconds				00 = μs 01 = ms 10 = s 11 = min			0 to 511									
48	<b>Sleep Mode Timer/Cell Configuration</b>															Default (Hex): 83FF	Idle/Doze: (min) 16
49	<b>Mode Timer</b>															Sleep (min) 240	Mode Cells 3
	Time required to enter Sleep mode from the Doze mode when no current is detected.																
	<b>Cell Configuration</b>																
	Only these combinations are acceptable. Any other combination will prevent any FET from turning on.																
	CELL8	CELL7	CELL6	CELL5	CELL4	CELL3	CELL2	CELL1	MOD7	MOD6	MOD5	MOD4	MOD3	MOD2	MOD1	MOD0	
	8 7 6 5 4 3 2 1				NUMBER OF CELLS				Idle and Doze Mode: [MOD3:0] = 0 to 16 Minutes								
	1 0 0 0 0 1 1				3 Cells connected				Sleep Mode [MOD7:0] = 0 to 240 Minutes								
	1 1 0 0 0 1 1				4 Cells connected				Example: Value = 0101 1010 Idle/Doze = 10 minutes Sleep = 90 minutes								
	1 1 0 0 1 1 1				5 Cells connected												
	1 1 1 0 0 1 1 1				6 Cells connected												
	1 1 1 0 1 1 1 1				7 Cells connected												
	1 1 1 1 1 1 1 1				8 Cells connected												

TABLE 15. EEPROM REGISTER DETAIL (FEATURE CONTROLS)

BIT/ ADDR	7	6	5	4	3	2	1	0
4A	<b>CFPSD</b> <b>CELLF PSD</b>  1 = Activates PSD output when a "Cell Fail" condition occurs. 0 = Does NOT activate PSD output when a cell fails condition occurs.	Reserved	<b>XT2M</b> <b>xTemp 2 Mode</b> <b>Control</b>  1 = xT2 monitors FET temp. Cell balance outputs are not shut off when xT2 temperature exceeds Cell Balance limits 0 = xT2 monitors cell temp. (Normal operation.)	<b>TGain</b> <b>External Temp</b> <b>Gain</b>  1= Gain of iT, xT1 and xT2 inputs is 1x. 0 = Gain of iT, xT1 and xT2 inputs is 2x.	Reserved, this bit must be 0.	<b>PCFETE</b> <b>Precharge FET</b> <b>Enable</b>  1 = Precharge FET output turns on instead of the CFET output when any of the cell voltages are below the under the LVCHG threshold. 0= Precharge FET is not used	<b>DOWD</b> <b>Disable</b> <b>Open-Wire Scan</b>  1 = Disable the input open-wire detection scan 0 = Enable the input open-wire detection scan	<b>OWPSD</b> <b>Open-Wire PSD</b>  1 = Responds automatically to the input Open Wire condition AND sets PSD. 0 = Responds automatically to the input Open Wire condition and DOES NOT set PSD.
4B	<b>CBDD</b> <b>CB during</b> <b>Discharge</b>  1 = Do balance during discharge 0 = No balance during discharge When both CBDD and CBDC equal "0", cell balance is turned off.	<b>CBDC</b> <b>CB during</b> <b>Charge</b>  1 = Do balance during charge 0 = No balance during charge When both CBDD and CBDC equal "0", cell balance is turned off.	<b>DFODUV</b> <b>DFET on during</b> <b>UV (Charging)</b>  1 = Keep DFET on while the pack is charging, regardless of the cell voltage. This minimizes DFET power dissipation during UV, when the pack is charging 0 = Normal DFET operation.	<b>CFODOV</b> <b>CFET on during</b> <b>OV (Discharging)</b>  1 = Keep CFET on while the pack is discharging, regardless of the cell voltage. This minimizes CFET power dissipation during OV, when the pack is discharging 0 = Normal CFET operation.	<b>UVLOPD</b> <b>Enable UVLO</b> <b>Power-Down</b>  1 = The device powers down when detecting an UVLO condition. 0 = When a UVLO condition is detected, the device remains powered.	Reserved	Reserved	<b>CB_EOC</b> <b>Enable CBAL</b> <b>during EOC</b>  1= Cell balance occurs during EOC condition regardless of current direction. 0 = Cell balance turns off during EOC if there is no current flowing.
4C 4F	Reserved							
50 57	User EEPROM Available to the user (Note: There is no shadow memory associated with these registers).							

## Registers: Detailed (RAM)

TABLE 16. RAM REGISTER DETAIL (STATUS AND CONTROL)

BIT/ ADDR	7	6	5	4	3	2	1	0
<b>80</b> (Read only)	<b>CUT</b> Charge Under-Temp	<b>COT</b> Charge Over-Temp	<b>DUT</b> Discharge Under-Temp	<b>DOT</b> Discharge Over-Temp	<b>UVLO</b> Undervoltage Lockout	<b>UV</b> Undervoltage	<b>OVLO</b> Overvoltage Lockout	<b>OV</b> Overvoltage
These bits are set and reset by the device.	An external thermistor shows the temp is lower than the minimum charge temp limit.	An external thermistor shows the temp is higher than the maximum charge temp limit.	An external thermistor shows the temp is lower than the minimum discharge temp limit.	An external thermistor shows the temp is higher than the maximum discharge temp limit.	At least one cell is below the undervoltage lockout threshold.	At least one cell has an undervoltage condition.	At least one cell is above the overvoltage lockout threshold.	At least one cell has an overvoltage condition.
<b>81</b> (Read only)	<b>EOCHG</b> End of charge	Reserved	<b>OPEN</b> Open wire	<b>CELLF</b> Cell Fail	<b>DSC</b> Discharge Short-Circuit	<b>DOC</b> Discharge Overcurrent	<b>COC</b> Charge Overcurrent	<b>IOT</b> Internal Over-Temp
These bits are set and reset by the device	End of charge voltage reached.		An open input circuit is detected.	Indicates that there is more than the maximum allowable voltage difference between cells.	Short-circuit current detected.	Excessive Discharge current detected.	Excessive Charge current detected.	The internal sensor indicates an over-temperature condition.
<b>82</b> (Read only)	<b>LVCHG</b> Low Voltage Charge	<b>INT_SCAN</b> Internal Scan In-Progress	<b>ECC_FAIL</b> EEPROM Error Correct Fail	<b>ECC_USED</b> EEPROM Error Correct	<b>DCHING</b> Discharging	<b>CHING</b> Charging	<b>CH_PRSNT</b> Chgr Present	<b>LD_PRSNT</b> Load Present
These bits are set and reset by the device	At least one cell voltage < LVCHG threshold. If set, PCFET turns on instead of CFET.	When this bit is "0" for the duration of the internal scan.	EEPROM error correction failed. Two bits failed, error not corrected. Previous value retained.	EEPROM error correction used. One bit failed, bit error corrected.	Indicates that a discharge current is detected. Charge current is flowing out of the pack.	Indicates that a charge current is detected. Charge current is flowing into the pack.	Set to "1" during COC, while charger is attached. (CHMON > threshold.) If $\mu\text{CLMON} = "0"$ , bit resets automatically. If $\mu\text{CLMON} = "1"$ , bit resets by $\mu\text{C}$ read of register.	Set to "1" during DOC or DSC, while load attached. (LDMON < threshold.) If $\mu\text{CCMON} = "0"$ , bit resets automatically. If $\mu\text{CCMON} = "1"$ , bit resets by $\mu\text{C}$ read of register.
<b>83</b> (Read only)	Reserved	<b>IN_SLEEP</b> In Sleep Mode	<b>IN_DOZE</b> In Doze mode	<b>IN_IDLE</b> In Idle Mode	<b>CBUV</b> Cell Balance Undervoltage	<b>CBOV</b> Cell Balance Overvoltage	<b>CBUT</b> Cell Balance Under-Temp	<b>CBOT</b> Cell Balance Over-Temp
These bits are set and reset by the device		No scans. RGO remains on, VREF off. Monitors for a charger or load connection.	Scans every 512ms.	Scans every 256ms	All cell voltages < the minimum allowable cell balance voltage threshold.	All cell voltages > the maximum allowable cell balance voltage threshold.	xT1 or xT2 indicates temp < allowable cell balance low temperature threshold	xT1 or xT2 indicates temp > allowable cell balance high temperature threshold
<b>84</b> (R/W)	Cell balance FET control bits These bits control the cell balance when the external controller overrides the internal cell balance operation.							
	<b>CB80N</b>	<b>CB70N</b>	<b>CB60N</b>	<b>CB50N</b>	<b>CB40N</b>	<b>CB30N</b>	<b>CB20N</b>	<b>CB10N</b>
	If $\mu\text{CCBAL} = 1$ , $\text{CBAL\_ON} = 1$ and $\text{CBnON}$ bit = 1 the cell balance FET is on. If $\mu\text{CCBAL} = 0$ , $\text{CBAL\_ON} = 0$ or $\text{CBnON}$ bit = 0 the cell balance FET is off.							

TABLE 16. RAM REGISTER DETAIL (STATUS AND CONTROL) (Continued)

BIT/ ADDR	7	6	5	4	3	2	1	0
85 (R/W)	Analog MUX control bits Voltage monitored by ADC when microcontroller overrides the internal scan operation.							
	Current Gain Setting Current gain set when current is monitored by ADC. Only used when microcontroller overrides the internal scan.							
	ADC Conversion Start							
	Reserved	ADCSTRT	CG1	CG0	A03	A02	A01	A00
	Ext $\mu$ C sets this bit to 1 to start a conversion	CG1 0 Gain 0 0 x50 0 1 x5 1 0 x500 1 1 x500		A03 2 1 0 0 0 0 0 OFF 0 0 0 1 VC1 0 0 1 0 VC2 0 0 1 1 VC3 0 1 0 0 VC4 0 1 0 1 VC5 0 1 1 0 VC6 0 1 1 1 VC7		A03 2 1 0 1 0 0 0 VC8 1 0 0 1 Pack current 1 0 1 0 VBAT/16 1 0 1 1 RGO/2 1 1 0 0 xT1 1 1 0 1 xT2 1 1 1 0 IT 1 1 1 1 OFF		
86 (R/W)	<b>CLR_LERR</b> Clear load error  1 = Resets load monitor error condition. This bit is automatically cleared. Only active when $\mu$ CCMON = 1	<b>LMON_EN</b> Load monitor enable  1 = Load monitor on 0 = Load monitor off  Only active when $\mu$ CLMON = 1	<b>CLR_ERR</b> Clear charge error  1 = Resets charge monitor error condition. This bit is automatically cleared. Only active when $\mu$ CCMON = 1	<b>CMON_EN</b> Charge monitor enable  1 = Charger monitor on 0 = Charger monitor off. Only active when $\mu$ CCMON = 1	<b>PSD</b> Pack shut down  1 = PSD on 0 = PSD off	<b>PCFET</b> Pre-charge FET  1 = PCFET on 0 = PCFET off Bit = 0 if DOC or DSC, unless the automatic response is disabled by $\mu$ CFET bit. (28)	<b>CFET</b> Charge FET  1 = CFET on 0 = CFET off Bit = 0 if COC, unless the automatic response is disabled by $\mu$ CFET bit. (28)	<b>DFET</b> Discharge FET  1 = DFET on 0 = DFET off Bit = 0 if DOC or DSC unless the automatic response is disabled by $\mu$ CFET bit. (28)
87 (R/W)	Reserved	<b><math>\mu</math>CFET</b> $\mu$ C does FET control  1 = FETs controlled by external $\mu$ C. 0 = Norm automatic FET control (31), (34)	<b><math>\mu</math>CCBAL</b> $\mu$ C does cell balance  1 = Internal balance disabled. $\mu$ C manages cell balance 0 = internal balance enabled. (31)	<b><math>\mu</math>CLMON</b> $\mu$ C does load monitor  1 = Load monitor on 0 = Load monitor off (31)	<b><math>\mu</math>CCMON</b> $\mu$ C does charger mon  1 = Charge monitor on 0 = Charge monitor off (31)	<b><math>\mu</math>CSCAN</b> $\mu$ C does scan  1 = No auto scan. System controlled by $\mu$ C. 0 = Normal scan (31), (3333)	<b>OW_STRT</b> Open wire start  1 = Does one open-wire scan (bit auto reset to 0) 0 = No scan Only active if DOWD = 1 or $\mu$ CSCAN = 1	<b>CBAL_ON</b> Cell balance On  1 = (CBnON = 1) outputs ON 0 = Cell bal outputs OFF Only active if $\mu$ CCBAL = 1.
88 (R/W)	Reserved	Reserved	Reserved	Reserved	<b>PDWN</b> Power-Down  1 = Power-down the device. 0 = Normal operation	<b>SLEEP</b> Set Sleep  1 = Put device into Sleep mode. 0 = Normal operation	<b>DOZE</b> Set Doze  1 = Put device into Doze mode. 0 = Normal operation	<b>IDLE</b> Set Idle  1 = Put device into Idle mode 0 = Normal operation.
89 (R/W)	EEPROM Enable							EEEN
	Reserved. These bits should be zero.							0 = RAM access 1 = EEPROM access

**TABLE 17. RAM REGISTER DETAIL (MONITORED VOLTAGES)**

BIT/ ADDR	F 7	E 6	D 5	C 4	B 3	A 2	9 1	8 0	7	6	5	4	3	2	1	0
8A 8B	<b>Cell Minimum Voltage</b> This is the voltage of the cell with the minimum voltage.								$\frac{\text{HEXvalue}_{10} \times 1.8 \times 8}{4095 \times 3}$							
Reserved				CELLMI NB	CELLMI NA	CELLMI N9	CELLMI N8	CELLMI N7	CELLMI N6	CELLMI N5	CELLMI N4	CELLMI N3	CELLMI N2	CELLMI N1	CELLMI N0	
8C 8D	<b>Cell Maximum Voltage</b> This is the voltage of the cell with the maximum voltage.								$\frac{\text{HEXvalue}_{10} \times 1.8 \times 8}{4095 \times 3}$							
Reserved				CELLM AXB	CELLM AXA	CELLM AX9	CELLM AX8	CELLM AX7	CELLM AX6	CELLM AX5	CELLM AX4	CELLM AX3	CELLM AX2	CELLM AX1	CELLM AX0	
8E 8F	<b>Pack Current</b> This is the current flowing into or out of the pack.								$\frac{\text{HEXvalue}_{10} \times 1.8}{4095 \times \text{Gain} \times \text{SenseR}}$ <p style="text-align: right;">Polarity identified by CHING and DCHING bits.</p>							
Reserved				ISNSB	ISNSA	ISNS9	ISNS8	ISNS7	ISNS6	ISNS5	ISNS4	ISNS3	ISNS2	ISNS1	ISNS0	
90 91	<b>Cell 1 Voltage</b> This is the voltage of CELL1.								$\frac{\text{HEXvalue}_{10} \times 1.8 \times 8}{4095 \times 3}$							
Reserved				CELL1 B	CELL1 A	CELL1 9	CELL1 8	CELL1 7	CELL1 6	CELL1 5	CELL1 4	CELL1 3	CELL1 2	CELL1 1	CELL1 0	
92 93	<b>Cell 2 Voltage</b> This is the voltage of CELL2.								$\frac{\text{HEXvalue}_{10} \times 1.8 \times 8}{4095 \times 3}$							
Reserved				CELL2 B	CELL2 A	CELL2 9	CELL2 8	CELL2 7	CELL2 6	CELL2 5	CELL2 4	CELL2 3	CELL2 2	CELL2 1	CELL2 0	
94 95	<b>Cell 3 Voltage</b> This is the voltage of CELL3.								$\frac{\text{HEXvalue}_{10} \times 1.8 \times 8}{4095 \times 3}$							
Reserved				CELL3 B	CELL3 A	CELL3 9	CELL3 8	CELL3 7	CELL3 6	CELL3 5	CELL3 4	CELL3 3	CELL3 2	CELL3 1	CELL3 0	
96 97	<b>Cell 4 Voltage</b> This is the voltage of CELL4.								$\frac{\text{HEXvalue}_{10} \times 1.8 \times 8}{4095 \times 3}$							
Reserved				CELL4 B	CELL4 A	CELL4 9	CELL4 8	CELL4 7	CELL4 6	CELL4 5	CELL4 4	CELL4 3	CELL4 2	CELL4 1	CELL4 0	
98 99	<b>Cell 5 Voltage</b> This is the voltage of CELL5.								$\frac{\text{HEXvalue}_{10} \times 1.8 \times 8}{4095 \times 3}$							
Reserved				CELL5 B	CELL5 A	CELL5 9	CELL5 8	CELL5 7	CELL5 6	CELL5 5	CELL5 4	CELL5 3	CELL5 2	CELL5 1	CELL5 0	
9A 9B	<b>Cell 6 Voltage</b> This is the voltage of CELL6.								$\frac{\text{HEXvalue}_{10} \times 1.8 \times 8}{4095 \times 3}$							
Reserved				CELL6 B	CELL6 A	CELL6 9	CELL6 8	CELL6 7	CELL6 6	CELL6 5	CELL6 4	CELL6 3	CELL6 2	CELL6 1	CELL6 0	

**TABLE 17. RAM REGISTER DETAIL (MONITORED VOLTAGES) (Continued)**

BIT/ ADDR	F 7	E 6	D 5	C 4	B 3	A 2	9 1	8 0	7	6	5	4	3	2	1	0
9C 9D	<b>Cell 7 Voltage</b> This is the voltage of CELL7.								$\frac{\text{HEXvalue}_{10} \times 1.8 \times 8}{4095 \times 3}$							
Reserved				CELL7 B	CELL7 A	CELL7 9	CELL7 8	CELL7 7	CELL7 6	CELL7 5	CELL7 4	CELL7 3	CELL7 2	CELL7 1	CELL7 0	
9E 9F	<b>Cell 8 Voltage</b> This is the voltage of CELL8.								$\frac{\text{HEXvalue}_{10} \times 1.8 \times 8}{4095 \times 3}$							
Reserved				CELL8 B	CELL8 A	CELL8 9	CELL8 8	CELL8 7	CELL8 6	CELL8 5	CELL8 4	CELL8 3	CELL8 2	CELL8 1	CELL8 0	
A0 A1	<b>Internal Temperature</b> This is the voltage reported by the ISL94203 internal temperature sensor.								$\frac{\text{HEXvalue}_{10} \times 1.8}{4095}$							
Reserved				iTB	iTA	iT9	iT8	iT7	iT6	iT5	iT4	iT3	iT2	iT1	iT0	
A2 A3	<b>External 1 Temperature</b> This is the voltage reported by an external thermistor divider on the xT1 pin.								$\frac{\text{HEXvalue}_{10} \times 1.8}{4095}$							
Reserved				xT1B	xT1A	xT19	xT18	xT17	xT16	xT15	xT14	xT13	xT12	xT11	xT10	
A4 A5	<b>External 2 Temperature</b> This is the voltage reported by an external thermistor divider on the xT2 pin.								$\frac{\text{HEXvalue}_{10} \times 1.8}{4095}$							
Reserved				xT2B	xT2A	xT29	xT28	xT27	xT26	xT25	xT24	xT23	xT22	xT21	xT20	
A6 A7	<b>VBATT Voltage</b> This is the voltage of Pack.								$\frac{\text{HEXvalue}_{10} \times 1.8 \times 32}{4095}$							
Reserved				VBB	VBA	VB9	VB8	VB7	VB6	VB5	VB4	VB3	VB2	VB1	VB0	
A8 A9	<b>VRGO Voltage</b> This is the voltage of ISL94203 2.5V regulator.								$\frac{\text{HEXvalue}_{10} \times 1.8 \times 2}{4095}$							
Reserved				RGOB	RGOA	RGO 9	RGO 8	RGO 7	RGO 6	RGO 5	RGO 4	RGO 3	RGO 2	RGO 1	RGO 0	

**TABLE 17. RAM REGISTER DETAIL (MONITORED VOLTAGES) (Continued)**

BIT/ ADDR	F 7	E 6	D 5	C 4	B 3	A 2	9 1	8 0	7	6	5	4	3	2	1	0
AA AB	<p><b>14-Bit ADC Voltage</b>                      This is the calibrated voltage out of the ISL94203 ADC. In normal scan mode, this value is not usable, because it cannot be associated with a specific monitored voltage. However, when the <math>\mu</math>C takes over the scan operations, this value can be useful. This is a 2's complement number.</p> $\text{if } \dots \text{HEXvalue}_{10} \geq 8191 \rightarrow \frac{(\text{HEXvalue}_{10} - 16384) \times 1.8}{8191}$ $\text{else } \rightarrow \frac{\text{HEXvalue}_{10} \times 1.8}{8191}$															
	Reserved	ADC D	ADC C	ADC B	ADC A	ADC 9	ADC 8	ADC 7	ADC 6	ADC 5	ADC 4	ADC 3	ADC 2	ADC 1	ADC 0	

**NOTES:**

25. A "1" written to a control or configuration bit causes the action to be taken. A "1" read from a status bit indicates that the condition exists.
26. "Reserved" indicates that the bit or register is reserved for future expansion. When writing to RAM addresses, write a reserved bit with the value "0". Do not write to reserved registers at addresses 4CH through 4FH, 58H through 7FH or ACH through FFH. Ignore reserved bits that are returned in a read operation.
27. The IN\_SLEEP bit is cleared on initial power up, by the CHMON pin going high or by the LDMON pin going low.
28. When the automatic responses are enabled, these bits are automatically set and reset by hardware when any conditions indicate. When automatic responses are over-ridden, an external microcontroller I<sup>2</sup>C write operation controls the respective FET and a read of the register returns the current state of the FET drive output circuit (though not the actual voltage at the output pin).
29. Setting EEEN to 0 prior to a read or write to the EEPROM area results in a read or write to the shadow memory. Setting EEEN to "1" prior to a read or write from the EEPROM area results in a read or write from the non-volatile array locations.
30. Writes to EEPROM registers require that the EEEN bit be set to "1" and all other bits in EEPROM enable register set to "0" prior to the write operation.
31. This bit is reset when the Watchdog timer is active and expires.
32. The memory is configured as 8 pages of 16 bytes. The I<sup>2</sup>C can perform a "page write" to write all values on one page in a single cycle.
33. Setting this bit to "1" disables all internal voltage and temperature scans. When set to "1", the external  $\mu$ C needs to process all overvoltage, undervoltage, over-temp, under temp and all cell balance operations.
34. Short-Circuit, Open Wire, Internal Over Temperature, OVLO and UVLO faults, plus Sleep and FETSOFF conditions override the  $\mu$ CFET control bit and automatically force the appropriate power FETs off.

## Revision History

The revision history provided is for informational purposes only and is believed to be accurate, but not warranted. Please go to web to make sure you have the latest Revision.

DATE	REVISION	CHANGE
Apr 26, 2019	FN7626.6	Updated Links throughout document. Removed all references to "cascade" throughout document. Updated disclaimer.
Feb 17, 2016	FN7626.5	Added Related Literature section on page 1. Added ISL94203IRTZ-T7A to the Ordering Information table on page 4. Updated Figure 2 on page 7. Updated Figure 26 on page 34. Updated Figure 29 on page 40. Added "EEPROM Access" on page 49. Added "EEPROM Write" on page 49. Updated "EEPROM Read" on page 49. Updated "Synchronizing Microcontroller Operations with Internal Scan" on page 49. Updated Table 15 "82 (Read only)" on page 58.
Aug17, 2015	FN7626.4	Ordering Information table, page 4: Changed ISL94203EVAL1Z to ISL94203EVKIT1Z
Feb 11, 2015	FN7626.3	-Updated datasheet applying Intersil's standards. -Added RC circuit to VBATT in Figure 1 on page 1. -Moved Table of Contents to page 2. -In the "Pin Descriptions" on page 5 for FETSOFF, add the statement, "This pin should be pulled low when inactive." -Updated VBATT Pin Description on page 6. -Electrical Specifications, page 8, IVBATT, removed "leakage" from Test Condition. -Absolute Maximum Ratings, page 8. Updated ESD Ratings standard revision for HBM to JESD22-A114F and replaced Machine Model ratings with Charge Device Model, per current JEDEC standards. -In Figures 2, 12, 13 and 30: changed the VBATT series R to 100Ω and VBATT cap to ground to 470nF and the VCn cap to ground to 47nF. -Updated Figure 4 on page 16 to show response if LDMON and CHMON are active when device enters Sleep. -Updated Figure 7 on page 17 to show charge pump timing relative to FET turn on/off and corrected the turn on delay time. -Added INT_SCAN bit in RAM location 0x82 in Table 16 on page 58. The addition of the bit is not a change to the device. This bit and descriptions about its use, are provided to make use of a previously undocumented feature. -Added INT_SCAN bit to Figure 23 on page 31. -Moved Sections "PC Board Layout" and "QFN Package" to precede Section "EEPROM" on page 44. -"PC Board Layout" on page 44, fourth bullet, changed "PCB" to "ground plane" and added new bullet "VDD bypass and charge pump capacitors should use wide temperature and high frequency dielectric (X7R or better) and it is recommended that the rated voltage be 2X the maximum operating voltage." Added a second new bullet, "The charge pump and VDD bypass capacitors should be located close to the ISL94203 pins and VDD should have a good ground connection." Added a third new bullet, "An example PCB layout..." along with a new figure, Figure 33. -In Figure 2, added a pull-down resistor on FETSOFF. -In Equations 1 and 2 on page 35, Reversed the TGain values. Now, Equation 1 is for TGain = 1 and Equation 2 is for TGain = 0. -On page 38, in "Cell Balance" section updated the 7th bullet by changing from "If CELMAX is below CBUV" to "If CELMAX is below CBMIN" and "(CBUV + 117mV)" to "(CBMIN + 117mV)". -On page 38 in section updated the 8th bullet by changing from "If the CELMIN voltage is greater than the CBOV voltage" to "If the CELMIN voltage is greater than the CBMAX voltage" and "[CBOV - 117mV]" to "(CBMAX - 117mV)". -In Table 11 on page 42, updated Row1, Column 3 to read "32kHz 5mA pulses, 50% duty cycle" and Row 3, the Power FET turn-off current was changed from "20mA" to "13mA (CFET, PCFET) and 15mA (DFET)". -On page 53, CBMIN: Changed "If any cell is less than this voltage" to "If all cell voltages are less than this voltage". -On Page 52, CBMAX: Changed "If any cell is greater than this voltage" to "If all cell voltages are greater than this voltage". -In Table 16 on page 58, the description for COC is changed to read, "Excessive Charge current detected" and change DOC to read "Excessive Discharge current detected." -Updated the About Intersil verbiage -Updated POD from revision 1 to revision 2 changes are as follows: "added tolerance ± values"
Dec 5, 2012	FN7626.2	Initial Release.

# Package Outline Drawing

## L48.6x6

48 LEAD THIN QUAD FLAT NO-LEAD PLASTIC PACKAGE

Rev 2, 7/14

For the most recent package outline drawing, see [L48.6x6](#).

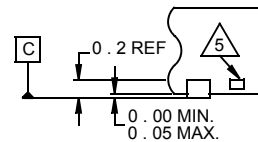
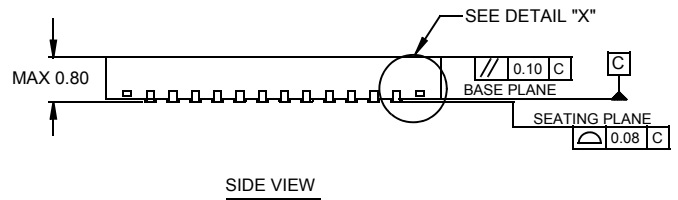
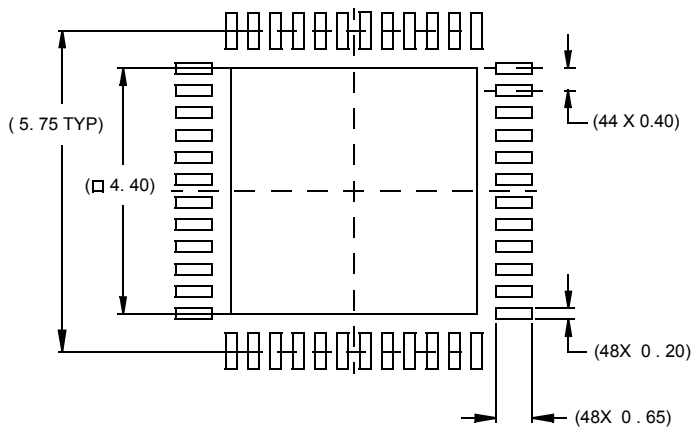
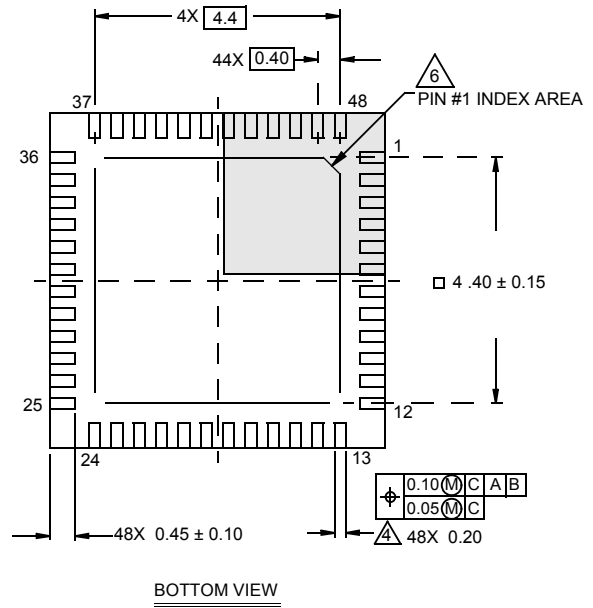
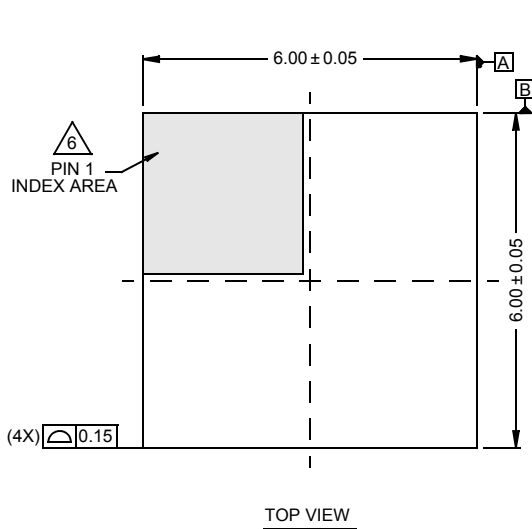

NOTES:

1. Dimensions are in millimeters.  
Dimensions in ( ) for Reference Only.
2. Dimensioning and tolerancing conform to AMSE Y14.5m-1994.
3. Unless otherwise specified, tolerance: Decimal ± 0.05
4. Dimension b applies to the metallized terminal and is measured between 0.15mm and 0.30mm from the terminal tip.
5. Tiebar shown (if present) is a non-functional feature.
6. The configuration of the pin #1 identifier is optional, but must be located within the zone indicated. The pin #1 identifier may be either a mold or mark feature.

## Notice

1. Descriptions of circuits, software and other related information in this document are provided only to illustrate the operation of semiconductor products and application examples. You are fully responsible for the incorporation or any other use of the circuits, software, and information in the design of your product or system. Renesas Electronics disclaims any and all liability for any losses and damages incurred by you or third parties arising from the use of these circuits, software, or information.
  2. Renesas Electronics hereby expressly disclaims any warranties against and liability for infringement or any other claims involving patents, copyrights, or other intellectual property rights of third parties, by or arising from the use of Renesas Electronics products or technical information described in this document, including but not limited to, the product data, drawings, charts, programs, algorithms, and application examples.
  3. No license, express, implied or otherwise, is granted hereby under any patents, copyrights or other intellectual property rights of Renesas Electronics or others.
  4. You shall not alter, modify, copy, or reverse engineer any Renesas Electronics product, whether in whole or in part. Renesas Electronics disclaims any and all liability for any losses or damages incurred by you or third parties arising from such alteration, modification, copying or reverse engineering.
  5. Renesas Electronics products are classified according to the following two quality grades: "Standard" and "High Quality". The intended applications for each Renesas Electronics product depends on the product's quality grade, as indicated below.
    - "Standard": Computers; office equipment; communications equipment; test and measurement equipment; audio and visual equipment; home electronic appliances; machine tools; personal electronic equipment; industrial robots; etc.
    - "High Quality": Transportation equipment (automobiles, trains, ships, etc.); traffic control (traffic lights); large-scale communication equipment; key financial terminal systems; safety control equipment; etc.Unless expressly designated as a high reliability product or a product for harsh environments in a Renesas Electronics data sheet or other Renesas Electronics document, Renesas Electronics products are not intended or authorized for use in products or systems that may pose a direct threat to human life or bodily injury (artificial life support devices or systems; surgical implantations; etc.), or may cause serious property damage (space system; undersea repeaters; nuclear power control systems; aircraft control systems; key plant systems; military equipment; etc.). Renesas Electronics disclaims any and all liability for any damages or losses incurred by you or any third parties arising from the use of any Renesas Electronics product that is inconsistent with any Renesas Electronics data sheet, user's manual or other Renesas Electronics document.
  6. When using Renesas Electronics products, refer to the latest product information (data sheets, user's manuals, application notes, "General Notes for Handling and Using Semiconductor Devices" in the reliability handbook, etc.), and ensure that usage conditions are within the ranges specified by Renesas Electronics with respect to maximum ratings, operating power supply voltage range, heat dissipation characteristics, installation, etc. Renesas Electronics disclaims any and all liability for any malfunctions, failure or accident arising out of the use of Renesas Electronics products outside of such specified ranges.
  7. Although Renesas Electronics endeavors to improve the quality and reliability of Renesas Electronics products, semiconductor products have specific characteristics, such as the occurrence of failure at a certain rate and malfunctions under certain use conditions. Unless designated as a high reliability product or a product for harsh environments in a Renesas Electronics data sheet or other Renesas Electronics document, Renesas Electronics products are not subject to radiation resistance design. You are responsible for implementing safety measures to guard against the possibility of bodily injury, injury or damage caused by fire, and/or danger to the public in the event of a failure or malfunction of Renesas Electronics products, such as safety design for hardware and software, including but not limited to redundancy, fire control and malfunction prevention, appropriate treatment for aging degradation or any other appropriate measures. Because the evaluation of microcomputer software alone is very difficult and impractical, you are responsible for evaluating the safety of the final products or systems manufactured by you.
  8. Please contact a Renesas Electronics sales office for details as to environmental matters such as the environmental compatibility of each Renesas Electronics product. You are responsible for carefully and sufficiently investigating applicable laws and regulations that regulate the inclusion or use of controlled substances, including without limitation, the EU RoHS Directive, and using Renesas Electronics products in compliance with all these applicable laws and regulations. Renesas Electronics disclaims any and all liability for damages or losses occurring as a result of your noncompliance with applicable laws and regulations.
  9. Renesas Electronics products and technologies shall not be used for or incorporated into any products or systems whose manufacture, use, or sale is prohibited under any applicable domestic or foreign laws or regulations. You shall comply with any applicable export control laws and regulations promulgated and administered by the governments of any countries asserting jurisdiction over the parties or transactions.
  10. It is the responsibility of the buyer or distributor of Renesas Electronics products, or any other party who distributes, disposes of, or otherwise sells or transfers the product to a third party, to notify such third party in advance of the contents and conditions set forth in this document.
  11. This document shall not be reprinted, reproduced or duplicated in any form, in whole or in part, without prior written consent of Renesas Electronics.
  12. Please contact a Renesas Electronics sales office if you have any questions regarding the information contained in this document or Renesas Electronics products.
- (Note1) "Renesas Electronics" as used in this document means Renesas Electronics Corporation and also includes its directly or indirectly controlled subsidiaries.
- (Note2) "Renesas Electronics product(s)" means any product developed or manufactured by or for Renesas Electronics.

(Rev.4.0-1 November 2017)

## Corporate Headquarters

TOYOSU FORESIA, 3-2-24 Toyosu,  
Koto-ku, Tokyo 135-0061, Japan  
[www.renesas.com](http://www.renesas.com)

## Contact Information

For further information on a product, technology, the most up-to-date version of a document, or your nearest sales office, please visit:  
[www.renesas.com/contact/](http://www.renesas.com/contact/)

## Trademarks

Renesas and the Renesas logo are trademarks of Renesas Electronics Corporation. All trademarks and registered trademarks are the property of their respective owners.

## Looking for pricing, stock, or lifecycle information?

Click below to explore more details on WIN SOURCE:

 [View ISL94203IRTZ-T7A on WIN SOURCE](#)

 [Intersil Information](#)

## Optimize Your Supply Chain with WIN SOURCE Solutions

-  Global Sourcing Solution
-  Obsolete Management
-  Cost Control Management
-  Shortage Management
-  Alternative Solution
-  Excess Inventory Management