

ISL81334, ISL41334

±15kV ESD Protected, Two Port, Dual Protocol Transceivers

FN6202
Rev.4.00
Mar 24, 2017

The [ISL81334](#) and [ISL41334](#) are two-port interface ICs in which each port can be independently configured as a single RS-485, RS-422 transceiver, or as a dual (2 Tx, 2 Rx) RS-232 transceiver. With both ports set to the same mode, two RS-485, RS-422 transceivers, or four RS-232 transceivers are available.

If either port is in RS-232 mode, the onboard charge pump generates RS-232 compliant ±5V Tx output levels from a single V_{CC} supply as low as 4.5V. Four small 0.1µF capacitors are required for the charge pump. The transceivers are RS-232 compliant, with the Rx inputs handling up to ±25V, and the Tx outputs handling ±12V.

In RS-485 mode, the transceivers support both the RS-485 and RS-422 differential communication standards. The receivers feature “full fail-safe” operation, so the Rx outputs remain in a high state if the inputs are open or shorted together. The transmitters support up to three data rates, two of which are slew rate limited for problem-free communications. The charge pump disables when both ports are in RS-485 mode, thereby saving power, minimizing noise, and eliminating the charge pump capacitors.

Both RS-232 and RS-485 modes feature loopback and shutdown functions. Loopback internally connects the Tx outputs to the corresponding Rx input, to facilitate board level self-test implementation. The outputs remain connected to the loads during loopback, so connection problems (such as shorted connectors or cables) can be detected. Shutdown mode disables the Tx and Rx outputs, disables the charge pumps, and places the IC in a low current (µA) mode.

The ISL41334 is a QFN packaged device that includes two additional user selectable, lower speed, and edge rate options for EMI-sensitive designs, or to allow longer bus lengths. It also features a logic supply pin (V_L) that sets the V_{OH} level of logic outputs, and the switching points of logic inputs, to be compatible with another supply voltage in mixed voltage systems. The QFN also adds active low Rx enable pins to increase design flexibility, allowing Tx/Rx direction control, through a single signal per port, by connecting the corresponding DE and $\overline{\text{RXEN}}$ pins together.

For a single port version of these devices, please see the [ISL81387](#), [ISL41387](#) datasheet.

Features

- ±15kV (HBM) ESD protected bus pins (RS-232 or RS-485)
- Two independent ports, each user selectable for RS-232 (2 transceivers) or RS-485, RS-422 (1 transceiver)
- Single 5V (10% tolerance) supply
- Flow-through pinouts simplify board layouts
- Pb-Free (RoHS compliant)
- Large (2.7V) differential V_{OUT} for improved noise immunity in RS-485, RS-422 networks
- Full fail-safe (open/short) Rx in RS-485, RS-422 mode
- Loopback mode facilitates board self-test functions
- User selectable RS-485 data rates (ISL41334 only)
 - Fast speed. 20Mbps
 - Slew rate limited 460kbps
 - Slew rate limited 115kbps
- Fast RS-232 data rate up to 650kbps
- Low current Shutdown mode 42µA
- QFN package saves board space (ISL41334 only)
- Logic supply pin (V_L) eases operation in mixed supply systems (ISL41334 only)

Applications

- Gaming applications (such as, slot machines)
- Single board computers
- Factory automation
- Security networks
- Industrial/process control networks
- Level translators, such as RS-232 to RS-422
- Point of sale equipment
- Dual channel RS-485 interfaces

Related Literature

- For a full list of related documents, visit our website
 - [ISL81334](#), [ISL41334](#) product pages

Table of Contents

Ordering Information	3
Pin Configurations	3
Pin Descriptions	4
ISL81334 Truth Tables	5
ISL41334 Truth Tables	6
Typical Operating Circuit	7
Absolute Maximum Ratings	8
Thermal Information	8
Operating Conditions	8
Electrical Specifications	8
Test Circuits and Waveforms	12
Typical Application	14
RS-232 to RS-485 Converter	14
Detailed Description	14
ISL81334 and ISL41334 Advantages	15
RS-232 Mode	16
Rx Features	16
Tx Features	16
Charge Pumps	16
Data Rates and Cabling	16
RS-485 Mode	16
Rx Features	16
Tx Features	17
Speed Options	17
Data Rate, Cables, and Terminations	17
High ESD	17
Small Packages	18
Flow Through Pinouts	18
Low Power Shutdown (SHDN) Mode	18
Internal Loopback Mode	18
ISL41334 (QFN Package) Special Features	18
Logic Supply (VL Pin)	18
Active Low Rx Enable (RXEN)	19
RS-485 Slew Rate Limited Data Rates	19
Evaluation Board	20
Typical Performance Curves	20
Die Characteristics	26
Revision History	27
About Intersil	27
Package Outline Drawing	28
L40.6x6	28
M28.3	29
M28.209	30

TABLE 1. SUMMARY OF FEATURES

PART NUMBER	NO. OF PORTS	PACKAGE OPTIONS	RS-485 DATA RATE (bps)	RS-232 DATA RATE (kbps)	V _L PIN?	ACTIVE H or L Rx ENABLE?	LOW POWER SHUTDOWN?
ISL81334	2	28 Ld SOIC, 28 Ld SSOP	20M	650	NO	NONE	YES
ISL41334	2	40 Ld QFN (6mmx6mm)	20M, 460k, 115k	650	YES	L	YES

Ordering Information

PART NUMBER (Notes 2, 3)	PART MARKING	TEMP. RANGE (°C)	TAPE AND REEL (UNITS) (Note 1)	PACKAGE (RoHS COMPLIANT)	PKG. DWG. #
ISL81334IAZ	81334 IAZ	-40 to +85	-	28 Ld SSOP	M28.209
ISL81334IAZ-T	81334 IAZ	-40 to +85	1k	28 Ld SSOP	M28.209
ISL81334IBZ	ISL81334IBZ	-40 to +85	-	28 Ld SOIC	M28.3
ISL81334IBZ-T	ISL81334IBZ	-40 to +85	1k	28 Ld SOIC	M28.3
ISL41334IRZ	41334 IRZ	-40 to +85	-	40 Ld QFN	L40.6x6
ISL41334IRZ-T	41334 IRZ	-40 to +85	4k	40 Ld QFN	L40.6x6
ISL41334IRZ-T7A	41334 IRZ	-40 to +85	250	40 Ld QFN	L40.6x6
ISL41334EVAL1Z	Evaluation board				

NOTES:

1. Refer to [TB347](#) for details on reel specifications.
2. These Intersil Pb-free plastic packaged products employ special Pb-free material sets, molding compounds/die attach materials, and 100% matte tin plate plus anneal (e3 termination finish, which is RoHS compliant and compatible with both SnPb and Pb-free soldering operations). Intersil Pb-free products are MSL classified at Pb-free peak reflow temperatures that meet or exceed the Pb-free requirements of IPC/JEDEC J STD-020.
3. For Moisture Sensitivity Level (MSL), see product information page for [ISL81334](#), [ISL41334](#). For more information on MSL, see tech brief [TB363](#).

Pin Configurations

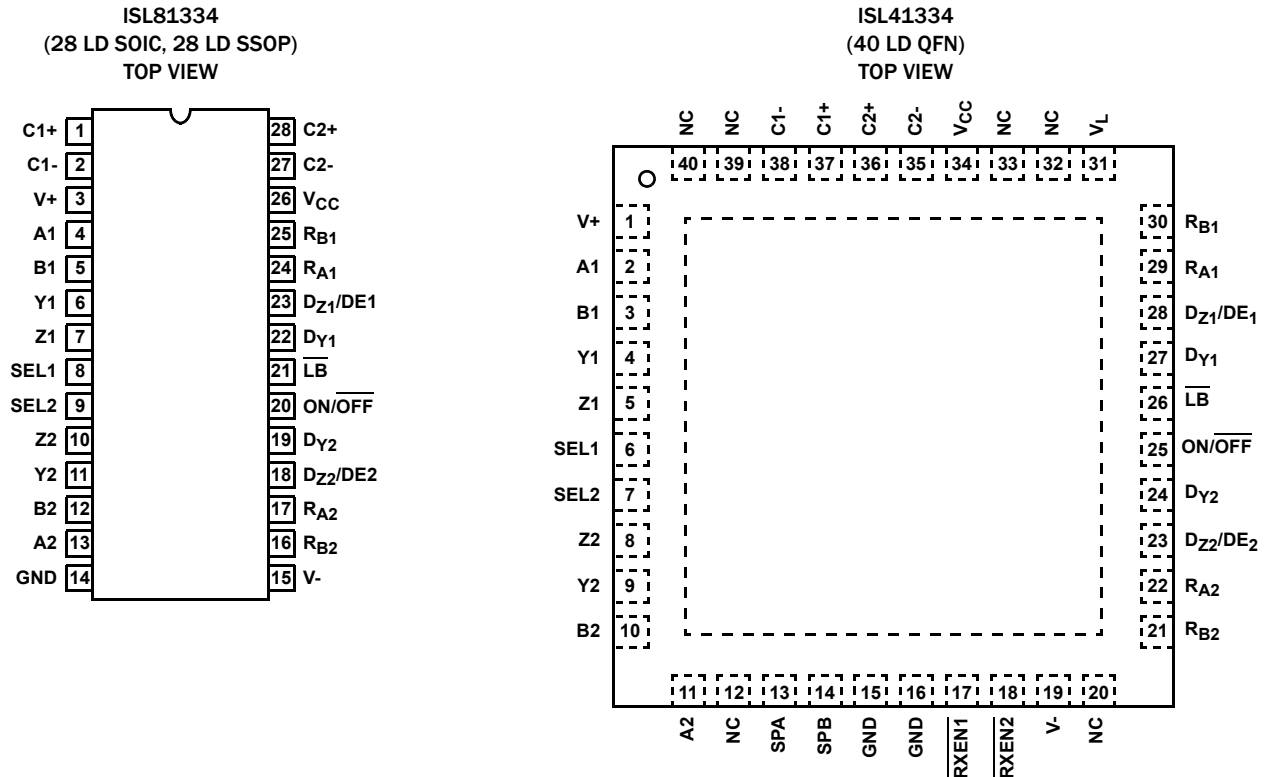

Pin Descriptions

PIN	MODE	FUNCTION
GND	BOTH	Ground connection.
$\overline{\text{LB}}$	BOTH	Loopback mode. In the ISL81334, Loopback mode is enabled when $\overline{\text{LB}}$ is low. In the ISL41334, Loopback mode is enabled when $\overline{\text{LB}}$ and $\overline{\text{RXEN}}$ are low.
NC	BOTH	No Connection.
$\text{ON}/\overline{\text{OFF}}$	BOTH	If either port is in RS-232 mode, a low on $\text{ON}/\overline{\text{OFF}}$ disables the charge pumps. In either mode, a low disables all the outputs, and places the device in low power shutdown. Internally pulled-high. ON = 1 for normal operation.
$\overline{\text{RXEN1}}$ $\overline{\text{RXEN2}}$	BOTH	Active low receiver output enable. Rx is enabled when $\overline{\text{RXEN}}$ is low; Rx is high impedance when $\overline{\text{RXEN}}$ is high. Internally pulled low. (QFN only)
SEL_x	BOTH	Interface mode Select input. High puts corresponding port in RS-485 mode, while a low puts it in RS-232 mode.
V_{CC}	BOTH	System power supply input (5V).
V_{L}	BOTH	Logic-Level Supply. All TTL/CMOS inputs and outputs are powered by this supply. QFN logic input pins that are externally tied high in the application should use the V_{L} supply for the high voltage level. (QFN only)
A_x	RS-232 RS-485	Receiver input with $\pm 15\text{kV}$ ESD protection. A low on A_x forces R_{A_x} high; a high on A_x forces R_{A_x} low. Inverting receiver input with $\pm 15\text{kV}$ ESD protection.
B_x	RS-232 RS-485	Receiver input with $\pm 15\text{kV}$ ESD protection. A low on B_x forces R_{B_x} high; a high on B_x forces R_{B_x} low. Noninverting receiver input with $\pm 15\text{kV}$ ESD protection.
D_{Y_x}	RS-232 RS-485	Driver input. A low on D_{Y_x} forces output Y_x high. Similarly, a high on D_{Y_x} forces output Y_x low. Driver input. A low on D_{Y_x} forces output Y_x high and output Z low. Similarly, a high on D_Y forces output Y_x low and output Z_x high.
D_{Z_x}	RS-232	Driver input. A low on D_{Z_x} forces output Z_x high. Similarly, a high on D_Z forces output Z_x low.

Pin Descriptions

PIN	MODE	FUNCTION
DEx	RS-485	Driver output enable. The driver outputs, Yx and Zx, are enabled by bringing DE high. They are high impedance when DE is low. Internally pulled high when port selected for RS-485 mode.
RAx	RS-232	Receiver output.
	RS-485	Receiver output: If Bx > Ax by at least -40mV, RAx is high; If Bx < Ax by -200mV or more, RAx is low; RAx = High if Ax and Bx are unconnected (floating) or shorted together (i.e., full fail-safe).
RBx	RS-232	Receiver output.
	RS-485	Not used. Internally pulled-high, and unaffected by RXEN.
Yx	RS-232	Driver output with ±15kV ESD protection.
	RS-485	Inverting driver output with ±15kV ESD protection.
Zx	RS-232	Driver output with ±15kV ESD protection.
	RS-485	Noninverting driver output with ±15kV ESD protection.
SPx	RS-485	Speed control. Internally pulled-high. (QFN only)
C1+	RS-232	External capacitor (voltage doubler) is connected to this lead. Not needed if both ports in RS-485 mode.
C1-	RS-232	External capacitor (voltage doubler) is connected to this lead. Not needed if both ports in RS-485 mode.
C2+	RS-232	External capacitor (voltage inverter) is connected to this lead. Not needed if both ports in RS-485 mode.
C2-	RS-232	External capacitor (voltage inverter) is connected to this lead. Not needed if both ports in RS-485 mode.
V+	RS-232	Internally generated positive RS-232 transmitter supply (+5.5V). C3 not needed if both ports in RS-485 mode.
V-	RS-232	Internally generated negative RS-232 transmitter supply (-5.5V). C4 not needed if both ports in RS-485 mode.

TABLE 2. ISL81334 FUNCTION TABLE

INPUTS			RECEIVER OUTPUTS		DRIVER OUTPUTS		CHARGE PUMPS (Note 4)	MODE
SEL1 or 2	ON/OFF	DE1 or 2	R _{Ax}	R _{Bx}	Yx	Zx		
0	1	N.A.	ON	ON	ON	ON	ON	RS-232
X	0	X	High-Z	High-Z	High-Z	High-Z	OFF	Shutdown
1	1	0	ON	High-Z (Note 5)	High-Z	High-Z	OFF	RS-485
1	1	1	ON	High-Z (Note 5)	ON	ON	OFF	RS-485

NOTE:

- Charge pumps are off if SEL1 = SEL2 = 1, or if ON/OFF = 0. If ON = 1, and either port is programmed for RS-232 mode, then the charge pumps are on.
- Internally pulled high through a 40kΩ resistor.

ISL81334 Truth Tables (for each port)

RS-232 TRANSMITTING MODE					
INPUTS				OUTPUTS	
SEL1 or 2	ON/OFF	D _{Yx}	D _{Zx}	Yx	Zx
0	1	0	0	1	1
0	1	0	1	1	0
0	1	1	0	0	1
0	1	1	1	0	0
0	0	X	X	High-Z	High-Z

RS-232 RECEIVING MODE					
INPUTS				OUTPUT	
SEL1 or 2	ON/OFF	Ax	Bx	R _{Ax}	R _{Bx}
0	1	0	0	1	1
0	1	0	1	1	0
0	1	1	0	0	1
0	1	1	1	0	0
0	1	Open	Open	1	1
0	0	X	X	High-Z	High-Z

RS-485 TRANSMITTING MODE					
INPUTS				OUTPUTS	
SEL1 or 2	ON/OFF	DE1 or 2	D _{Yx}	Yx	Zx
1	1	1	0	1	0
1	1	1	1	0	1
1	1	0	X	High-Z	High-Z
1	0	X	X	High-Z	High-Z

RS-485 RECEIVING MODE				
INPUTS			OUTPUT	
SEL1 or 2	ON/OFF	Bx-Ax	R _{Ax}	R _{Bx} (Note 6)
1	1	≥ -40mV	1	High-Z
1	1	≤ -200mV	0	High-Z
1	1	Open or Shorted together	1	High-Z
1	0	X	High-Z	High-Z

NOTE:

- Internally pulled high through a 40kΩ resistor.

TABLE 3. ISL41334 FUNCTION TABLE

INPUTS						RECEIVER OUTPUTS		DRIVER OUTPUTS		CHARGE PUMPS (Note 7)	DRIVER DATA RATE (Mbps)	MODE
SEL1 or 2	ON/OFF	SPA	SPB	RXEN1 or 2	DE1 or 2	R _{Ax}	R _{Bx}	Yx	Zx			
0	1	X	X	0	N.A.	ON	ON	ON	ON	ON	0.46	RS-232
0	1	X	X	1	N.A.	High-Z	High-Z	ON	ON	ON	0.46	RS-232
X	0	X	X	X	X	High-Z	High-Z	High-Z	High-Z	OFF	N.A.	Shutdown
1	1	X	X	0	0	ON	High-Z (Note 8)	High-Z	High-Z	OFF	N.A.	RS-485
1	1	0	0	0	1	ON	High-Z (Note 8)	ON	ON	OFF	0.46	RS-485
1	1	0	1	0	1	ON	High-Z (Note 8)	ON	ON	OFF	0.115	RS-485
1	1	1	0	0	1	ON	High-Z (Note 8)	ON	ON	OFF	20	RS-485
1	1	1	1	0	1	ON	High-Z (Note 8)	ON	ON	OFF	20	RS-485
1	1	X	X	1	0	High-Z	High-Z (Note 8)	High-Z	High-Z	OFF	N.A.	RS-485
1	1	0	0	1	1	High-Z	High-Z (Note 8)	ON	ON	OFF	0.46	RS-485
1	1	0	1	1	1	High-Z	High-Z (Note 8)	ON	ON	OFF	0.115	RS-485
1	1	1	0	1	1	High-Z	High-Z (Note 8)	ON	ON	OFF	20	RS-485
1	1	1	1	1	1	High-Z	High-Z (Note 8)	ON	ON	OFF	20	RS-485

NOTE:

- 7. Charge pumps are off if SEL1 = SEL2 = 1, or if ON/OFF = 0. If ON = 1, and either port is programmed for RS-232 mode, then the charge pumps are on.
- 8. Internally pulled high through a 40kΩ resistor.

ISL41334 Truth Tables (for each port)

RS-232 TRANSMITTING MODE					
INPUTS				OUTPUTS	
SEL1 or 2	ON/OFF	D _{Yx}	D _{Zx}	Yx	Zx
0	1	0	0	1	1
0	1	0	1	1	0
0	1	1	0	0	1
0	1	1	1	0	0
0	0	X	X	High-Z	High-Z

RS-485 TRANSMITTING MODE								
INPUTS						OUTPUTS		DATA RATE (Mbps)
SEL1 or 2	ON/OFF	DE1 or 2	SPA	SPB	D _{Yx}	Yx	Zx	
1	1	1	0	0	0/1	1/0	0/1	0.46
1	1	1	0	1	0/1	1/0	0/1	0.115
1	1	1	1	X	0/1	1/0	0/1	20
1	1	0	X	X	X	High-Z	High-Z	N.A.
1	0	X	X	X	X	High-Z	High-Z	N.A.

RS-232 RECEIVING MODE						
INPUTS					OUTPUT	
SEL1 or 2	ON/OFF	RXEN1 or 2	Ax	Bx	R _{Ax}	R _{Bx}
0	1	0	0	0	1	1
0	1	0	0	1	1	0
0	1	0	1	0	0	1
0	1	0	1	1	0	0
0	1	0	Open	Open	1	1
0	1	1	X	X	High-Z	High-Z
0	0	X	X	X	High-Z	High-Z

RS-485 RECEIVING MODE					
INPUTS				OUTPUT	
SEL1 or 2	ON/OFF	RXEN1 or 2	Bx-Ax	R _{Ax}	R _{Bx} (Note 9)
1	1	0	≥ -40mV	1	High-Z
1	1	0	≤ -200mV	0	High-Z
1	1	0	Open or Shorted together	1	High-Z
1	1	1	X	High-Z	High-Z
1	0	X	X	High-Z	High-Z

NOTE:

- 9. Internally pulled high through a 40kΩ resistor.

Typical Operating Circuits

Red pin numbers = Port 1, Blue pin numbers = Port 2

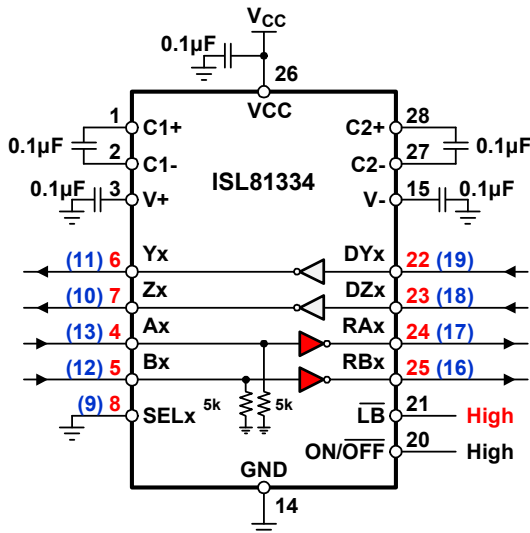

NOTE: PINOUT FOR SOIC AND SSOP SAME FOR PORT 2.

FIGURE 1. RS-232 MODE WITHOUT LOOPBACK

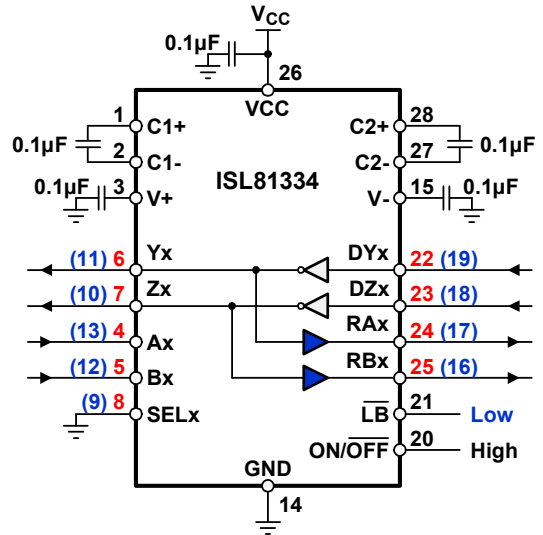

NOTE: PINOUT FOR SOIC AND SSOP SAME FOR PORT 2.

FIGURE 2. RS-232 MODE WITH LOOPBACK

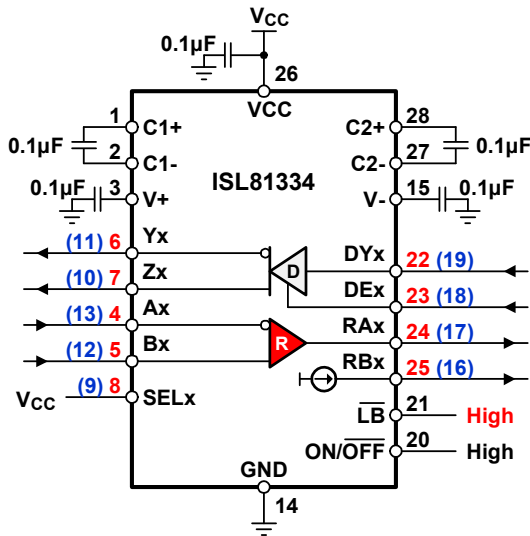

NOTE: PINOUT FOR SOIC AND SSOP SAME FOR PORT 2.

FIGURE 3. RS-485 MODE WITHOUT LOOPBACK

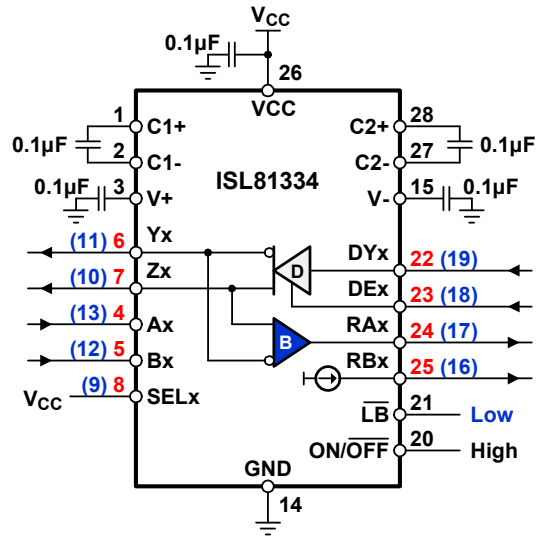

NOTE: PINOUT FOR SOIC AND SSOP SAME FOR PORT 2.

FIGURE 4. RS-485 MODE WITH LOOPBACK

Typical Operating Circuits (Continued)

Red pin numbers = Port 1, Blue pin numbers = Port 2

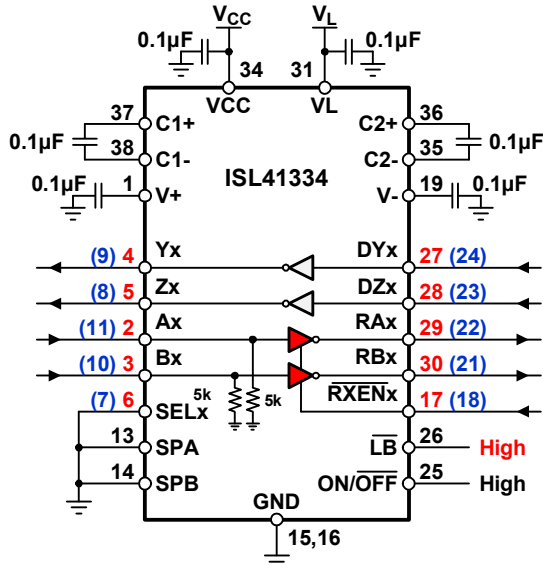

NOTE: PINOUT FOR SOIC AND SSOP SAME FOR PORT 2.

FIGURE 5. RS-232 MODE WITHOUT LOOPBACK

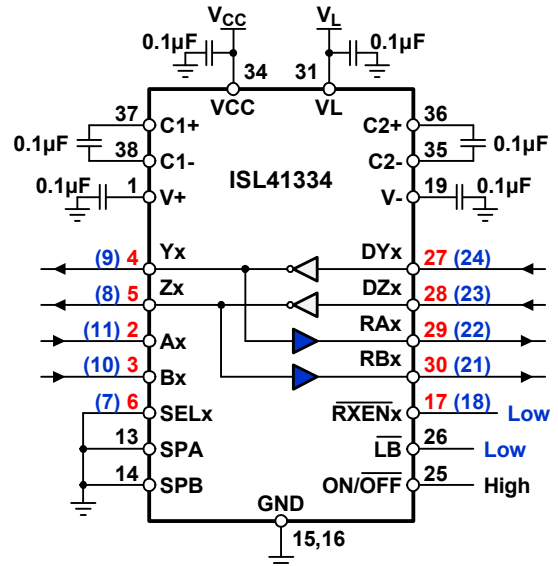

NOTE: PINOUT FOR SOIC AND SSOP SAME FOR PORT 2.

FIGURE 6. RS-232 MODE WITH LOOPBACK

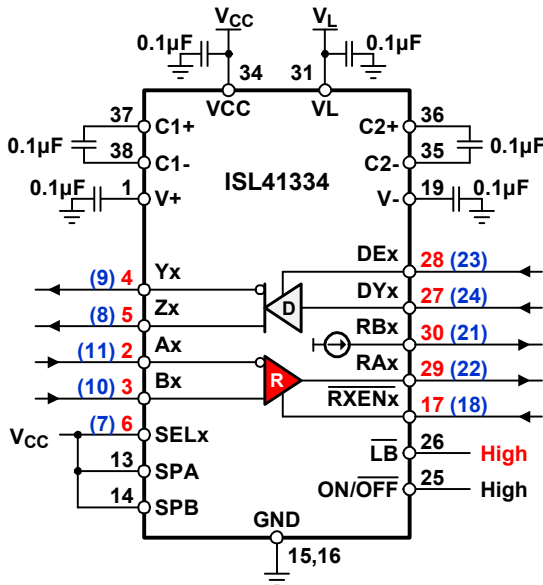

NOTE: PINOUT FOR SOIC AND SSOP SAME FOR PORT 2.

FIGURE 7. RS-485 MODE WITHOUT LOOPBACK

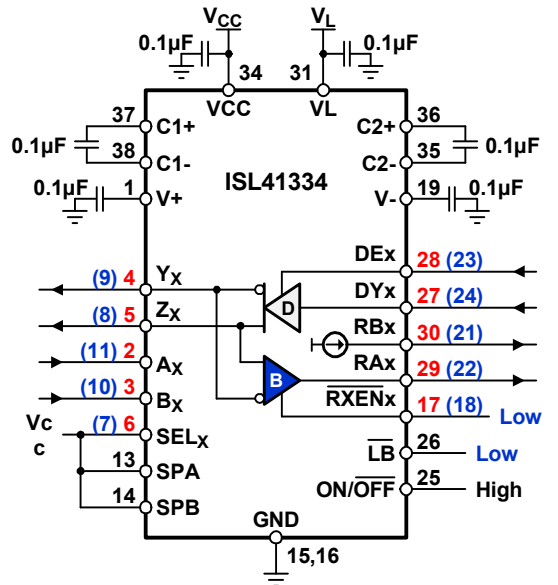

NOTE: PINOUT FOR SOIC AND SSOP SAME FOR PORT 2.

FIGURE 8. RS-485 MODE WITH LOOPBACK

Absolute Maximum Ratings ($T_A = +25^\circ\text{C}$)

V_{CC} to Ground	7V
V_L (QFN only)	-0.5V to $V_{CC} + 0.5V$
Input Voltages	
All Except Ax, Bx	-0.5V to 7V
Input/Output Voltages	
Ax, Bx (Any Mode)	-25V to +25V
Yx, Zx (Any Mode, Note 10)	-12.5V to +12.5V
R_{Ax} , R_{Bx} (Non-QFN Package)	-0.5V to ($V_{CC} + 0.5V$)
R_{Ax} , R_{Bx} (QFN Package)	-0.5V to ($V_L + 0.5V$)
Output Short-Circuit Duration	
Yx, Zx, R_{Ax} , R_{Bx}	Indefinite
ESD Rating	See Specification Table

Thermal Information

Thermal Resistance	θ_{JA} ($^\circ\text{C}/\text{W}$)
28 Ld SOIC Package (Note 12)	65
28 Ld SSOP Package (Note 12)	60
40 Ld QFN Package (Note 11)	32
Maximum Junction Temperature (Plastic Package)	+150 $^\circ\text{C}$
Maximum Storage Temperature Range	-65 $^\circ\text{C}$ to +150 $^\circ\text{C}$
Pb-Free Reflow Profile	see TB493

Operating Conditions

Temperature Range	-40 $^\circ\text{C}$ to +85 $^\circ\text{C}$
-------------------	--

CAUTION: Do not operate at or near the maximum ratings listed for extended periods of time. Exposure to such conditions may adversely impact product reliability and result in failures not covered by warranty.

NOTES:

- One output at a time, $I_{OUT} \leq 100\text{mA}$ for ≤ 10 mins.
- θ_{JA} is measured in free air with the component mounted on a high-effective thermal conductivity test board with "direct attach" features. See tech brief [TB379](#).
- θ_{JA} is measured with the component mounted on a high-effective thermal conductivity test board in free air. See tech brief [TB379](#) for details.

Electrical Specifications Test Conditions: $V_{CC} = 4.5V$ to $5.5V$, $C_1 - C_4 = 0.1\mu\text{F}$, $V_L = V_{CC}$ (for QFN only); unless otherwise specified. Typical values are at $V_{CC} = 5V$, $T_A = +25^\circ\text{C}$ ([Note 13](#)).

PARAMETER	SYMBOL	TEST CONDITIONS	TEMP ($^\circ\text{C}$)	MIN (Note 18)	TYP	MAX (Note 18)	UNIT	
DC CHARACTERISTICS - RS-485 DRIVER (SELx = V_{CC})								
Driver Differential V_{OUT} (no load)	V_{OD1}		Full	-	-	V_{CC}	V	
Driver Differential V_{OUT} (with load)	V_{OD2}	$R = 50\Omega$ (RS-422) (Figure 9)	Full	2.5	3.1	-	V	
		$R = 27\Omega$ (RS-485) (Figure 9)	Full	2.2	2.7	5	V	
	V_{OD3}	$R_D = 60\Omega$, $R = 375\Omega$, $V_{CM} = -7V$ to $12V$ (Figure 9)	Full	2	2.7	5	V	
Change in Magnitude of Driver Differential V_{OUT} for Complementary Output States	ΔV_{OD}	$R = 27\Omega$ or 50Ω (Figure 9)	Full	-	0.01	0.2	V	
Driver Common-Mode V_{OUT}	V_{OC}	$R = 27\Omega$ or 50Ω (Figure 9) (Note 17)	Full	-	-	3.1	V	
Change in Magnitude of Driver Common-Mode V_{OUT} for Complementary Output States	ΔV_{OC}	$R = 27\Omega$ or 50Ω (Figure 9) (Note 17)	Full	-	0.01	0.2	V	
Driver Short-Circuit Current, $V_{OUT} = \text{High or Low}$	I_{OS}	$-7V \leq (V_Y \text{ or } V_Z) \leq 12V$ (Note 15)	Full	35	-	250	mA	
Driver Three-State Output Leakage Current (Yx, Zx)	I_{OZ}	Outputs Disabled, $V_{CC} = 0V$ or $5.5V$	$V_{OUT} = 12V$	Full	-	-	500	μA
			$V_{OUT} = -7V$	Full	-200	-	-	μA
DC CHARACTERISTICS - RS-232 DRIVER (SELx = GND)								
Driver Output Voltage Swing	V_O	All T_{OUTS} Loaded with $3k\Omega$ to Ground	Full	± 5.0	+6/-7	-	V	
Driver Output Short-Circuit Current	I_{OS}	$V_{OUT} = 0V$	Full	-60	25/-35	60	mA	
DC CHARACTERISTICS - LOGIC PINS (SUCH AS DRIVER AND CONTROL INPUT PINS)								
Input High Voltage	V_{IH1}	$V_L = V_{CC}$ if QFN	Full	2	1.6	-	V	
	V_{IH2}	$V_L = 3.3V$ (QFN only)	Full	2	1.2	-	V	
	V_{IH3}	$V_L = 2.5V$ (QFN only)	Full	1.5	1	-	V	

Electrical Specifications Test Conditions: $V_{CC} = 4.5V$ to $5.5V$, $C_1 - C_4 = 0.1\mu F$, $V_L = V_{CC}$ (for QFN only); unless otherwise specified. Typical values are at $V_{CC} = 5V$, $T_A = +25^\circ C$ (Note 13). (Continued)

PARAMETER	SYMBOL	TEST CONDITIONS	TEMP (°C)	MIN (Note 18)	TYP	MAX (Note 18)	UNIT	
Input Low Voltage	V_{IL1}	$V_L = V_{CC}$ if QFN	Full	-	1.4	0.8	V	
	V_{IL2}	$V_L = 3.3V$ (QFN only)	Full	-	1	0.7	V	
	V_{IL3}	$V_L = 2.5V$ (QFN only)	Full	-	-	0.5	V	
Input Current	I_{IN1}	Pins Without pull-ups or pull-downs	Full	-2	-	2	μA	
	I_{IN2}	\overline{LB} , ON/\overline{OFF} , DEX , SPx (QFN), \overline{RXENx} (QFN)	Full	-25	-	25	μA	
DC CHARACTERISTICS - RS-485 RECEIVER INPUTS (SELx = V_{CC})								
Receiver Differential Threshold Voltage	V_{TH}	$-7V \leq V_{CM} \leq 12V$, full fail-safe	Full	-0.2	-	-0.04	V	
Receiver Input Hysteresis	ΔV_{TH}	$V_{CM} = 0V$	25	-	35	-	mV	
Receiver Input Current (Ax, Bx)	I_{IN}	$V_{CC} = 0V$ or 4.5 to $5.5V$	$V_{IN} = 12V$	Full	-	-	0.8	mA
			$V_{IN} = -7V$	Full	-0.64	-	-	mA
Receiver Input Resistance	R_{IN}	$-7V \leq V_{CM} \leq 12V$, $V_{CC} = 0$ (Note 16) or $4.5V \leq V_{CC} \leq 5.5V$	Full	15	-	-	k Ω	
DC CHARACTERISTICS - RS-232 RECEIVER INPUTS (SELx = GND)								
Receiver Input Voltage Range	V_{IN}		Full	-25	-	25	V	
Receiver Input Threshold	V_{IL}		Full	-	1.4	0.8	V	
	V_{IH}		Full	2.4	1.9	-	V	
Receiver Input Hysteresis	ΔV_{TH}		25	-	0.5	-	V	
Receiver Input Resistance	R_{IN}	$V_{IN} = \pm 15V$, V_{CC} Powered Up (Note 16)	Full	3	5	7	k Ω	
DC CHARACTERISTICS - RECEIVER OUTPUTS (485 OR 232 MODE)								
Receiver Output High Voltage	V_{OH1}	$I_O = -2mA$ ($V_L = V_{CC}$ if QFN)	Full	3.5	4.6	-	V	
	V_{OH2}	$I_O = -650\mu A$, $V_L = 3V$ (QFN only)	Full	2.6	2.9	-	V	
	V_{OH3}	$I_O = -500\mu A$, $V_L = 2.5V$ (QFN only)	Full	2	2.4	-	V	
Receiver Output Low Voltage	V_{OL}	$I_O = 3mA$	Full	-	0.1	0.4	V	
Receiver Short-Circuit Current	I_{OSR}	$0V \leq V_O \leq V_{CC}$	Full	7	-	85	mA	
Receiver Three-State Output Current	I_{OZR}	Output disabled, $0V \leq V_O \leq V_{CC}$ (or V_L for QFN)	Full	-	-	± 10	μA	
Unused Receiver (R_{Bx}) Pull-Up Resistance	R_{OBZ}	$ON/\overline{OFF} = V_{CC}$, $SELx = V_{CC}$ (RS-485 mode)	25	-	40	-	k Ω	
POWER SUPPLY CHARACTERISTICS								
No-Load Supply Current (Note 14)	I_{CC232}	$SEL1$ or $SEL2 = GND$, $\overline{LB} = ON/\overline{OFF} = V_{CC}$	Full	-	3.7	7	mA	
	I_{CC485}	$SEL1$ and $2 = \overline{LB} = DE = ON/\overline{OFF} = V_{CC}$	Full	-	1.6	5	mA	
Shutdown Supply Current	$I_{SHDN232}$	$ON/\overline{OFF} = SELx = GND$, $\overline{LB} = V_{CC}$, ($SPx = V_{CC}$ if QFN)	Full	-	25	50	μA	
		$I_{SHDN485}$	$ON/\overline{OFF} = DEX = GND$, $SELx = \overline{LB} = V_{CC}$, ($SPx = GND$ if QFN)	SOIC/SSOP	Full	-	42	80
	QFN			Full	-	80	160	μA
ESD CHARACTERISTICS								
Bus Pins (Ax, Bx, Yx, Zx) Any Mode		Human body model	25	-	15	-	kV	
All Other Pins		Human body model	25	-	4	-	kV	

Electrical Specifications Test Conditions: $V_{CC} = 4.5V$ to $5.5V$, $C_1 - C_4 = 0.1\mu F$, $V_L = V_{CC}$ (for QFN only); unless otherwise specified. Typical values are at $V_{CC} = 5V$, $T_A = +25^\circ C$ (Note 13). (Continued)

PARAMETER	SYMBOL	TEST CONDITIONS	TEMP (°C)	MIN (Note 18)	TYP	MAX (Note 18)	UNIT	
RS-232 DRIVER AND RECEIVER SWITCHING CHARACTERISTICS (SELx = GND, ALL VERSIONS AND SPEEDS)								
Driver Output Transition Region Slew Rate	SR	$R_L = 3k\Omega$, Measured From 3V to -3V or -3V to 3V	$C_L \geq 15pF$	Full	-	18	30	V/ μs
			$C_L \leq 2500pF$	Full	4	12	-	V/ μs
Driver Output Transition Time	t_r, t_f	$R_L = 3k\Omega$, $C_L = 2500pF$, 10% to 90%	Full	0.22	1.2	3.1	μs	
Driver Propagation Delay	t_{DPHL}	$R_L = 3k\Omega$, $C_L = 1000pF$ (Figure 14)	Full	-	1	2	μs	
	t_{DPLH}		Full	-	1.2	2	μs	
Driver Propagation Delay Skew	t_{DSKEW}	$t_{DPHL} - t_{DPLH}$ (Figure 14)	Full	-	240	400	ns	
Driver Enable Time from Shutdown	t_{DENSD}	$V_{OUT} = \pm 3.0V$	25	-	20	-	μs	
Driver Maximum Data Rate	DR_D	$R_L = 3k\Omega$, $C_L = 1000pF$, One Transmitter Switching per port	Full	460	650	-	kbps	
Receiver Propagation Delay	t_{RPHL}	$C_L = 15pF$ (Figure 15)	Full	-	50	120	ns	
	t_{RPLH}		Full	-	40	120	ns	
Receiver Propagation Delay Skew	t_{RSKEW}	$t_{RPHL} - t_{RPLH}$ (Figure 15)	Full	-	10	40	ns	
Receiver Maximum Data Rate	DR_R	$C_L = 15pF$	Full	0.46	2	-	Mbps	
RS-485 DRIVER SWITCHING CHARACTERISTICS (FAST DATA RATE (20Mbps), SELx = V_{CC}, ALL VERSIONS (SPA = V_{CC} if QFN))								
Driver Differential Input to Output Delay	t_{DLH}, t_{DHL}	$R_{DIFF} = 54\Omega$, $C_L = 100pF$ (Figure 10)	Full	15	30	50	ns	
Driver Output Skew	t_{SKEW}	$R_{DIFF} = 54\Omega$, $C_L = 100pF$ (Figure 10)	Full	-	3	10	ns	
Driver Differential Rise or Fall Time	t_r, t_f	$R_{DIFF} = 54\Omega$, $C_L = 100pF$ (Figure 10)	Full	3	11	20	ns	
Driver Enable to Output Low	t_{ZL}	$C_L = 100pF$, SW = V_{CC} (Figure 11)	Full	-	27	60	ns	
Driver Enable to Output High	t_{ZH}	$C_L = 100pF$, SW = GND (Figure 11)	Full	-	24	60	ns	
Driver Disable from Output Low	t_{LZ}	$C_L = 15pF$, SW = V_{CC} (Figure 11)	Full	-	31	60	ns	
Driver Disable from Output High	t_{HZ}	$C_L = 15pF$, SW = GND (Figure 11)	Full	-	24	60	ns	
Driver Enable from Shutdown to Output Low	$t_{ZL(SHDN)}$	$R_L = 500\Omega$, $C_L = 100pF$, SW = V_{CC} (Figure 11)	Full	-	65	250	ns	
Driver Enable from Shutdown to Output High	$t_{ZH(SHDN)}$	$R_L = 500\Omega$, $C_L = 100pF$, SW = GND (Figure 11)	Full	-	152	250	ns	
Driver Maximum Data Rate	f_{MAX}	$R_{DIFF} = 54\Omega$, $C_L = 100pF$ (Figure 10)	Full	-	30	-	Mbps	
RS-485 DRIVER SWITCHING CHARACTERISTICS (MEDIUM DATA RATE (460kbps, QFN ONLY), SELx = V_{CC}, SPA = SPB = GND)								
Driver Differential Input to Output Delay	t_{DLH}, t_{DHL}	$R_{DIFF} = 54\Omega$, $C_L = 100pF$ (Figure 10)	Full	200	490	1000	ns	
Driver Output Skew	t_{SKEW}	$R_{DIFF} = 54\Omega$, $C_L = 100pF$ (Figure 10)	Full	-	110	400	ns	
Driver Differential Rise or Fall Time	t_r, t_f	$R_{DIFF} = 54\Omega$, $C_L = 100pF$ (Figure 10)	Full	300	600	1100	ns	
Driver Enable to Output Low	t_{ZL}	$C_L = 100pF$, SW = V_{CC} (Figure 11)	Full	-	30	300	ns	
Driver Enable to Output High	t_{ZH}	$C_L = 100pF$, SW = GND (Figure 11)	Full	-	128	300	ns	
Driver Disable from Output Low	t_{LZ}	$C_L = 15pF$, SW = V_{CC} (Figure 11)	Full	-	31	60	ns	
Driver Disable from Output High	t_{HZ}	$C_L = 15pF$, SW = GND (Figure 11)	Full	-	24	60	ns	
Driver Enable from Shutdown to Output Low	$t_{ZL(SHDN)}$	$R_L = 500\Omega$, $C_L = 100pF$, SW = V_{CC} (Figure 11)	Full	-	65	500	ns	
Driver Enable from Shutdown to Output High	$t_{ZH(SHDN)}$	$R_L = 500\Omega$, $C_L = 100pF$, SW = GND (Figure 11)	Full	-	255	500	ns	

Electrical Specifications Test Conditions: $V_{CC} = 4.5V$ to $5.5V$, $C_1 - C_4 = 0.1\mu F$, $V_L = V_{CC}$ (for QFN only); unless otherwise specified. Typical values are at $V_{CC} = 5V$, $T_A = +25^\circ C$ (Note 13). (Continued)

PARAMETER	SYMBOL	TEST CONDITIONS	TEMP (°C)	MIN (Note 18)	TYP	MAX (Note 18)	UNIT	
Driver Maximum Data Rate	f_{MAX}	$R_{DIFF} = 54\Omega$, $C_L = 100pF$ (Figure 10)	Full	-	2000	-	kbps	
RS-485 DRIVER SWITCHING CHARACTERISTICS (SLOW DATA RATE (115kbps, QFN ONLY), SELx = V_{CC}, SPA = GND, SPB = V_{CC})								
Driver Differential Input to Output Delay	t_{DLH} , t_{DHL}	$R_{DIFF} = 54\Omega$, $C_L = 100pF$ (Figure 10)	Full	800	1500	2500	ns	
Driver Output Skew	t_{SKEW}	$R_{DIFF} = 54\Omega$, $C_L = 100pF$ (Figure 10)	Full	-	350	1250	ns	
Driver Differential Rise or Fall Time	t_R , t_F	$R_{DIFF} = 54\Omega$, $C_L = 100pF$ (Figure 10)	Full	1000	2000	3100	ns	
Driver Enable to Output Low	t_{ZL}	$C_L = 100pF$, $SW = V_{CC}$ (Figure 11)	Full	-	32	600	ns	
Driver Enable to Output High	t_{ZH}	$C_L = 100pF$, $SW = GND$ (Figure 11)	Full	-	300	600	ns	
Driver Disable from Output Low	t_{LZ}	$C_L = 15pF$, $SW = V_{CC}$ (Figure 11)	Full	-	31	60	ns	
Driver Disable from Output High	t_{HZ}	$C_L = 15pF$, $SW = GND$ (Figure 11)	Full	-	24	60	ns	
Driver Enable from Shutdown to Output Low	$t_{ZL(SHDN)}$	$R_L = 500\Omega$, $C_L = 100pF$, $SW = V_{CC}$ (Figure 11)	Full	-	65	800	ns	
Driver Enable from Shutdown to Output High	$t_{ZH(SHDN)}$	$R_L = 500\Omega$, $C_L = 100pF$, $SW = GND$ (Figure 11)	Full	-	420	800	ns	
Driver Maximum Data Rate	f_{MAX}	$R_{DIFF} = 54\Omega$, $C_L = 100pF$ (Figure 10)	Full	-	800	-	kbps	
RS-485 RECEIVER SWITCHING CHARACTERISTICS (SELx = V_{CC}, ALL VERSIONS AND SPEEDS)								
Receiver Input to Output Delay	t_{PLH} , t_{PHL}	(Figure 12)	Full	20	50	90	ns	
Receiver Skew $t_{PLH} - t_{PHL}$	t_{SKEW}	(Figure 12)	Full	-	0.1	10	ns	
Receiver Maximum Data Rate	f_{MAX}		Full	-	40	-	Mbps	
RECEIVER ENABLE/DISABLE CHARACTERISTICS (ALL MODES AND SPEEDS)								
Receiver Enable to Output Low	t_{ZL}	QFN Only, $C_L = 15pF$, $SW = V_{CC}$ (Figure 13)	Full	-	22	60	ns	
Receiver Enable to Output High	t_{ZH}	QFN Only, $C_L = 15pF$, $SW = GND$ (Figure 13)	Full	-	23	60	ns	
Receiver Disable from Output Low	t_{LZ}	QFN Only, $C_L = 15pF$, $SW = V_{CC}$ (Figure 13)	Full	-	24	60	ns	
Receiver Disable from Output High	t_{HZ}	QFN Only, $C_L = 15pF$, $SW = GND$ (Figure 13)	Full	-	25	60	ns	
Receiver Enable from Shutdown to Output Low	t_{ZLSHDN}	$C_L = 15pF$, $SW = V_{CC}$ (Figure 13)	RS-485 mode	Full	-	260	700	ns
			RS-232 mode	25	-	35	-	ns
Receiver Enable from Shutdown to Output High	t_{ZHSHDN}	$C_L = 15pF$, $SW = GND$ (Figure 13)	RS-485 mode	Full	-	260	700	ns
			RS-232 mode	25	-	25	-	ns

NOTES:

- All currents into device pins are positive; all currents out of device pins are negative. All voltages are referenced to device ground unless otherwise specified.
- Supply current specification is valid for loaded drivers when $DE = 0V$ (RS-485 mode only).
- Applies to peak current. See "Typical Performance Curves" starting on 22 for more information.
- R_{IN} defaults to RS-485 mode ($>15k\Omega$) when the device is unpowered ($V_{CC} = 0V$), or in SHDN, regardless of the state of the SELx inputs.
- $V_{CC} \leq 5.25V$.
- Parts are 100% tested at $+25^\circ C$. Over-temperature limits established by characterization and are not production tested.

Test Circuits and Waveforms

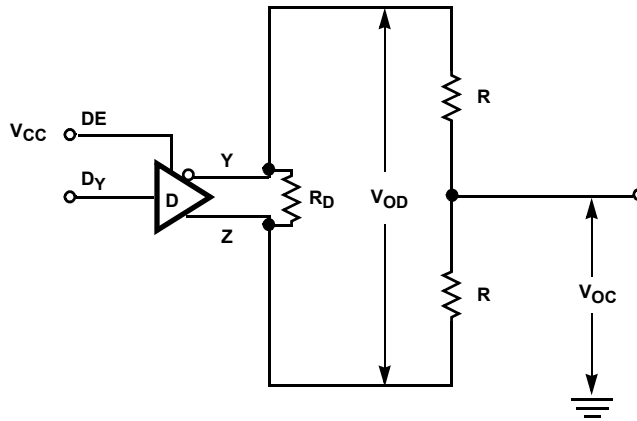

FIGURE 9. RS-485 DRIVER V_{OD} AND V_{OC} TEST CIRCUIT

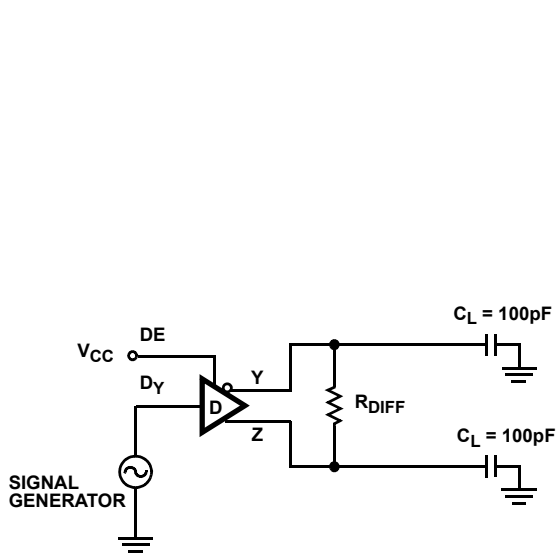

FIGURE 10A. TEST CIRCUIT

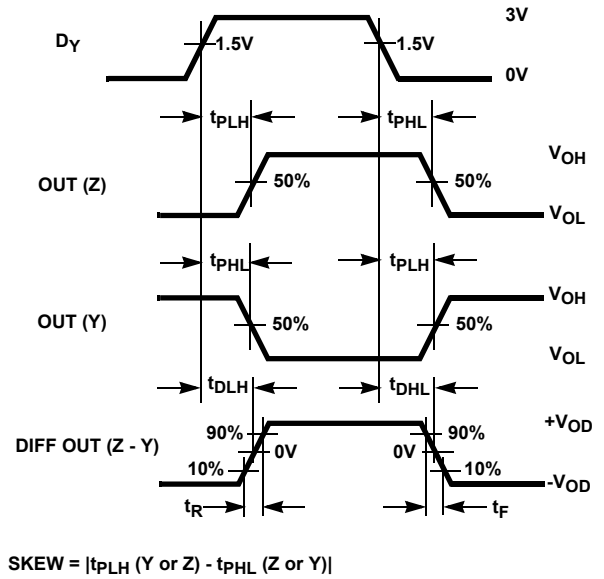
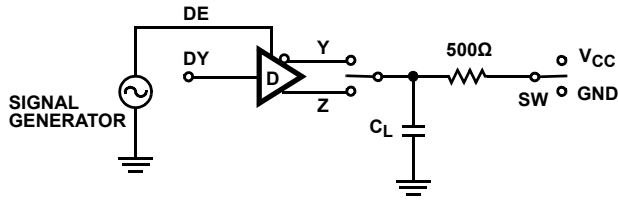

FIGURE 10B. MEASUREMENT POINTS

FIGURE 10. RS-485 DRIVER PROPAGATION DELAY AND DIFFERENTIAL TRANSITION TIMES

Test Circuits and Waveforms (Continued)



FOR SHDN TESTS, SWITCH ON/OFF RATHER THAN DE

PARAMETER	ON/DE	OUTPUT	DY	SW	CL (pF)
t _{HZ}	1/-	Y/Z	0/1	GND	15
t _{LZ}	1/-	Y/Z	1/0	V _{CC}	15
t _{ZH}	1/-	Y/Z	0/1	GND	100
t _{ZL}	1/-	Y/Z	1/0	V _{CC}	100
t _{ZH(SHDN)}	-/1	Y/Z	0/1	GND	100
t _{ZL(SHDN)}	-/1	Y/Z	1/0	V _{CC}	100

FIGURE 11A. TEST CIRCUIT

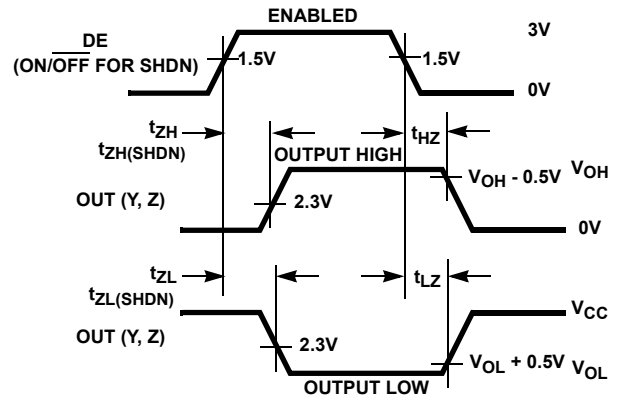

FIGURE 11B. MEASUREMENT POINTS

FIGURE 11. RS-485 DRIVER ENABLE AND DISABLE TIMES

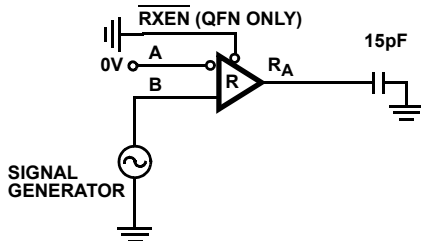

FIGURE 12A. TEST CIRCUIT

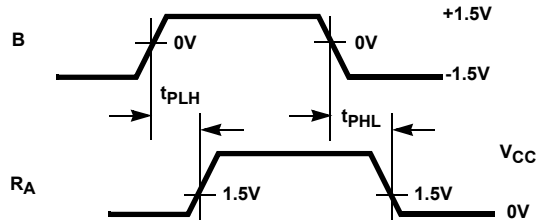
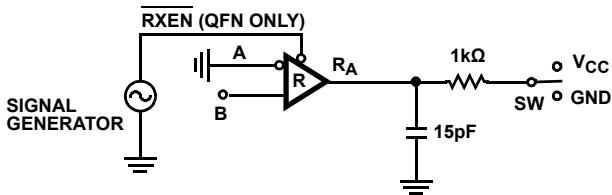

FIGURE 12B. MEASUREMENT POINTS

FIGURE 12. RS-485 RECEIVER PROPAGATION DELAY



FOR SHDN TESTS, SWITCH ON/OFF RATHER THAN RXEN

PARAMETER	ON/RXEN	B	SW
t _{HZ} (QFN Only)	1/-	+1.5V	GND
t _{LZ} (QFN Only)	1/-	-1.5V	V _{CC}
t _{ZH} (QFN Only)	1/-	+1.5V	GND
t _{ZL} (QFN Only)	1/-	-1.5V	V _{CC}
t _{ZH(SHDN)}	-/0	+1.5V	GND
t _{ZL(SHDN)}	-/0	-1.5V	V _{CC}

FIGURE 13A. TEST CIRCUIT

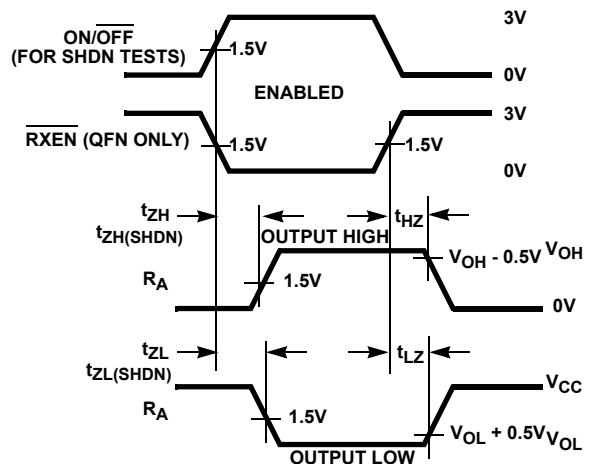

FIGURE 13B. MEASUREMENT POINTS

FIGURE 13. RS-485 RECEIVER ENABLE AND DISABLE TIMES

Test Circuits and Waveforms (Continued)

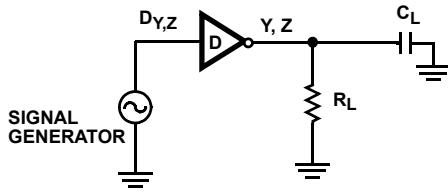

FIGURE 14A. TEST CIRCUIT

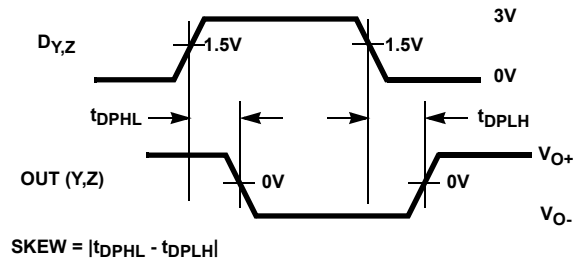

FIGURE 14B. MEASUREMENT POINTS

FIGURE 14. RS-232 DRIVER PROPAGATION DELAY AND TRANSITION TIMES

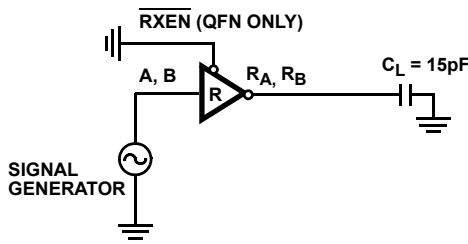

FIGURE 15A. TEST CIRCUIT

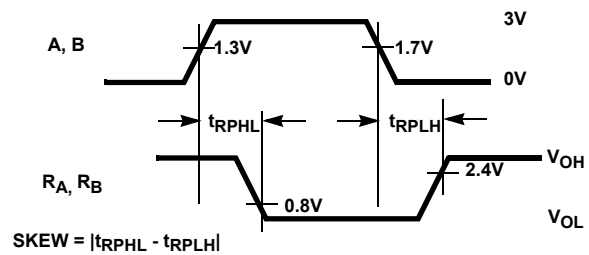

FIGURE 15B. MEASUREMENT POINTS

FIGURE 15. RS-232 RECEIVER PROPAGATION DELAY AND TRANSITION TIMES

Typical Application

RS-232 to RS-485 Converter

The ISL81334 and ISL41334 are ideal for implementing a single IC 2-wire (Tx Data, Rx Data) protocol converter, because each port can be programmed for a different protocol. Figure 16 illustrates the simple connections to create a single transceiver RS-232 to RS-485 converter. Depending on the RS-232 data rate, using an RS-422 bus as an RS-232 “extension cord” can extend the transmission distance up to 4000’ (1220m). A similar circuit on the other end of the cable completes the conversion to/from RS-232.

Detailed Description

Each of the two ISL81334 and ISL41334 ports support dual protocols: RS-485/422 and RS-232. RS-485 and RS-422 are differential (balanced) data transmission standards for use in high speed (up to 20Mbps) networks, or long haul and noisy environments. The differential signaling, coupled with RS-485’s requirement for extended Common-Mode Range (CMR) of +12V to -7V make these transceivers extremely tolerant of ground potential differences, as well as voltages induced in the cable by external fields. Both of these effects are real concerns when communicating over the RS-485, RS-422 maximum distance of 4000’ (1220m). It is important to note that the ISL81334 and ISL41334 do not follow the RS-485 convention whereby the inverting I/O is labeled “B/Z”, and the noninverting I/O is “A/Y”. Thus, in the application diagrams below the 1334 A/Y (B/Z) pins connect to the B/Z (A/Y) pins of the generic RS-485, RS-422 ICs.

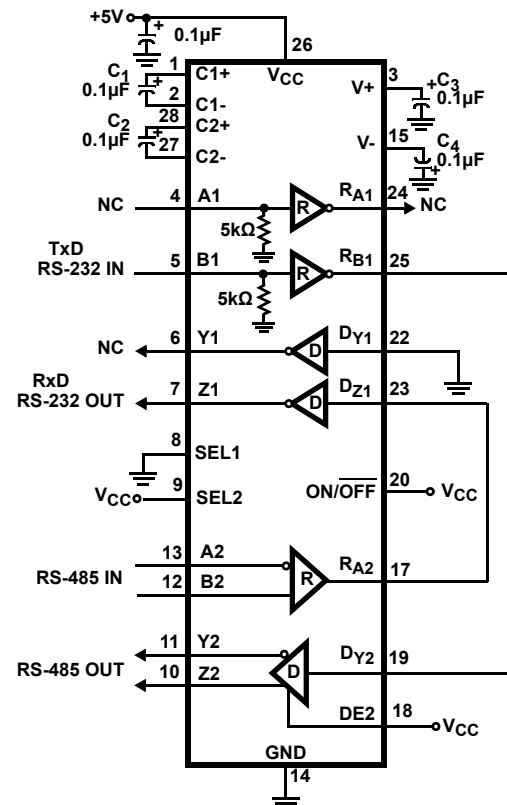

NOTE: PINOUT FOR SOIC AND SSOP

FIGURE 16. SINGLE IC RS-232 TO RS-485 CONVERTER

RS-422 is typically a point-to-point (one driver talking to one receiver on a bus) or a point-to-multipoint (multidrop) standard that allows only one driver and up to 10 receivers on each bus. Because of the one driver per bus limitation, RS-422 networks use a two bus, full duplex structure for bidirectional communication, and the Rx inputs and Tx outputs (no tri-state required) connect to different busses, as shown in [Figure 18](#).

Conversely, RS-485 is a true multipoint standard, which allows up to 32 devices (any combination of drivers—must be tri-statable—and receivers) on each bus. Now bidirectional communication takes place on a single bus, so the Rx inputs and Tx outputs of a port connect to the same bus lines, as shown in [Figure 17](#). Each port set to RS-485 /422 mode includes one Rx and one Tx.

RS-232 is a point-to-point, singled ended (signal voltages referenced to GND) communication protocol targeting fairly short (<150', 46m) and low data rate (<1Mbps) applications. Each port contains two transceivers (2 Tx and 2 Rx) in RS-232 mode.

Protocol selection is handled through a logic pin (SELx) for each port.

ISL81334 and ISL41334 Advantages

These dual protocol ICs offer many parametric improvements compared to those offered on competing dual protocol devices. Some of the major improvements are:

- 15kV bus pin ESD - Eases board level requirements
- 2.7V Diff V_{OUT} - Better noise immunity and/or distance
- Full fail-safe RS-485 Rx - Eliminates bus biasing
- Selectable RS-485 Data Rate - Up to 20Mbps, or slew rate limited for low EMI and fewer termination issues
- High RS-232 data rate - >460kbps
- Lower Tx and Rx skews - Wider, consistent bit widths
- Lower I_{CC} - Maximum I_{CC} is 2x to 4x lower than competition
- Flow-through pinouts - Tx and Rx bus pins on one side/logic pins on the other, for easy routing to connector/UART
- Smaller (SSOP and QFN) and RoHS compliant packaging.

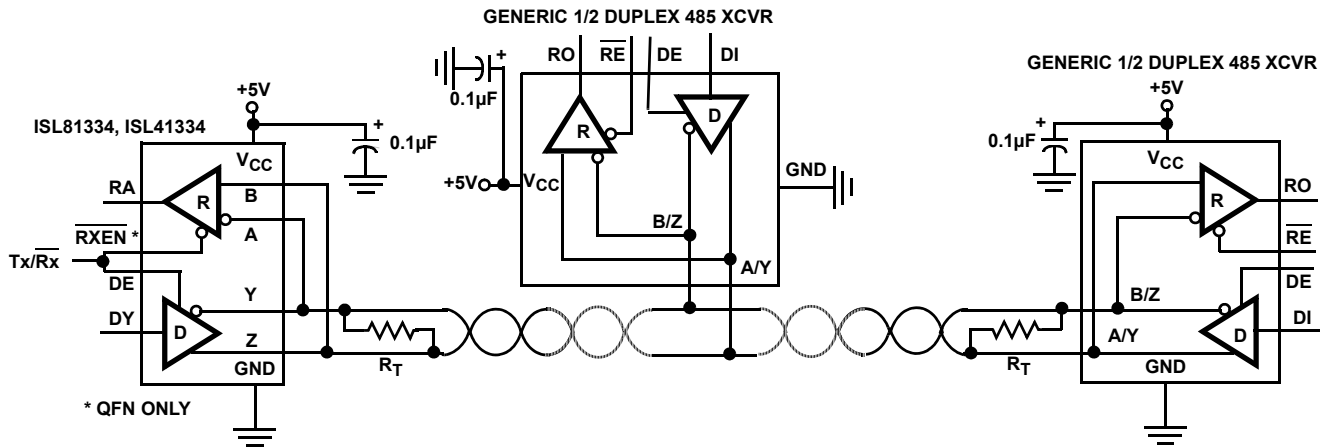

FIGURE 17. TYPICAL HALF DUPLEX RS-485 NETWORK

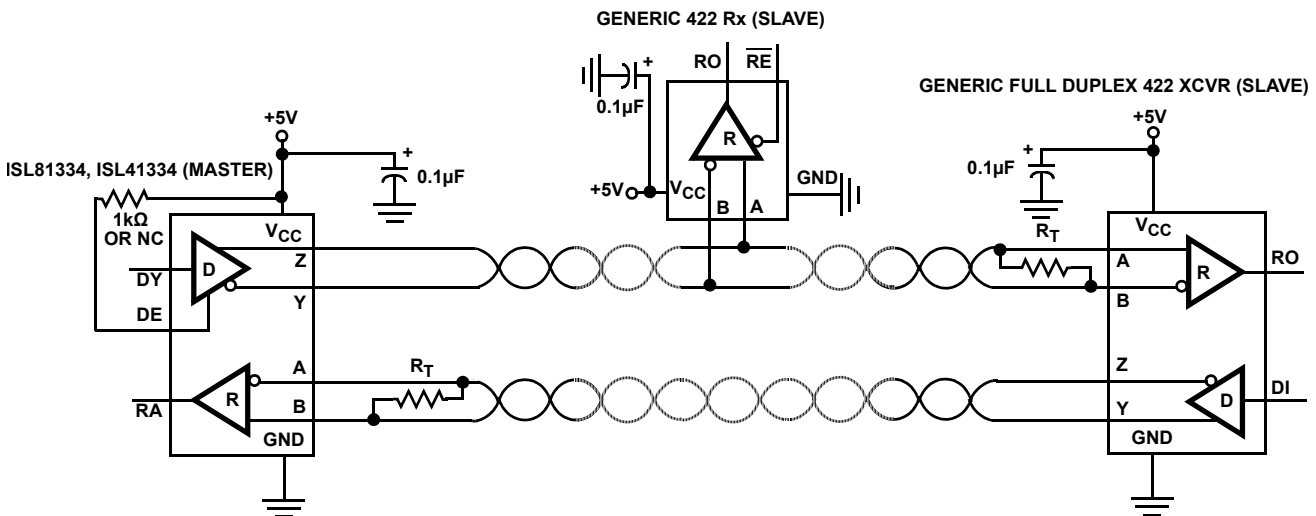

FIGURE 18. TYPICAL RS-422 NETWORK

RS-232 Mode

Rx Features

RS-232 receivers invert and convert RS-232 input levels ($\pm 3V$ to $\pm 25V$) to the standard TTL/CMOS levels required by a UART, ASIC, or microcontroller serial port. Receivers are designed to operate at faster data rates than the drivers, and they feature very low skews (10ns) so the receivers contribute negligibly to bit width distortion. Inputs include the standards required 3k Ω to 7k Ω pull-down resistor, so unused inputs may be left unconnected. Rx inputs also have built-in hysteresis to increase noise immunity, and to decrease erroneous triggering due to slowly transitioning input signals.

Rx outputs are short-circuit protected, and are only tri-statable when the entire IC is shut down through the ON/OFF pin, or through the active low RXEN pin available on the QFN package option (see [“ISL41334 \(QFN Package\) Special Features” on page 20](#) for more details).

Tx Features

RS-232 drivers invert and convert the standard TTL/CMOS levels from a UART or microcontroller serial port to RS-232 compliant levels ($\pm 5V$ minimum). The Tx delivers these compliant output levels even at data rates of 650kbps, and with loads of 1000pF. The drivers are designed for low skew (typically 12% of the 500kbps bit width), and are compliant to the RS-232 slew rate specification (4V/ μ s to 30V/ μ s) for a wide range of load capacitances. Tx inputs float if left unconnected, and may cause I_{CC} increases. For the best results, connect unused inputs to GND.

Tx outputs are short-circuit protected, and incorporate a thermal SHDN feature to protect the IC in situations of severe power dissipation. See [“RS-485 Mode”](#) for more details. Drivers tri-state only in SHDN, or when the 5V power supply is off. The SHDN function is useful for tri-stating the outputs if both ports will always be tri-stated together (for example, used as a four transceiver RS-232 port), and if it is acceptable for the Rx to be disabled as well. A single port Tx disable can be accomplished by switching the port to RS-485 mode, and then using the corresponding DE pin to tri-state the drivers. Of course, the Rx is now an RS-485 Rx, so this option is feasible only if the Rx are not needed when the Tx are disabled.

Charge Pumps

The on-chip charge pumps create the RS-232 transmitter power supplies (typically +6/-7V) from a single supply as low as 4.5V, and are enabled only if either port is configured for RS-232 operation. The efficient design requires only four small 0.1 μ F capacitors for the voltage doubler and inverter functions. By operating discontinuously (for example, turning off as soon as V+ and V- pump up to the nominal values), the charge pump contribution to RS-232 mode I_{CC} is reduced significantly. Unlike competing devices that require the charge pump in RS-485 mode, disabling the charge pump saves power, and minimizes noise. If the application keeps both ports in RS-485 mode (for example, a dedicated dual channel RS-485 interface), then the charge pump capacitors are not even required.

Data Rates and Cabling

Drivers operate at data rates of up to 650kbps, and are guaranteed for data rates of up to 460kbps. The charge pumps and drivers are designed so that one driver in each port can be operated at the rated load and at 460kbps (see [Figure 42](#)). [Figure 42](#) also shows that drivers can easily drive several thousands of picofarads at data rates up to 250kbps, while still delivering compliant $\pm 5V$ output levels.

Receivers operate at data rates up to 2Mbps. They are designed for a higher data rate to facilitate faster factory downloading of software into the final product, thereby improving the user's manufacturing throughput.

[Figures 45](#) and [46](#) illustrate driver and receiver waveforms at 250kbps and 500kbps, respectively. For these graphs, one driver of each port drives the specified capacitive load, and a receiver in the port.

RS-232 does not require anything special for cabling; just a single bus wire per transmitter and receiver, and another wire for GND. So ISL81334 and ISL41334 RS-232 ports use a five conductor cable for interconnection. Bus terminations are not required, nor allowed, by the RS-232 standard.

RS-485 Mode

Rx Features

RS-485 receivers convert differential input signals as small as 200mV to TTL/CMOS output levels, as required by the RS-485 and RS-422 standards. The differential Rx provides maximum sensitivity, noise immunity, and common-mode rejection. According to the RS-485 standard, receiver inputs function with common-mode voltages as great as $\pm 7V$ outside the power supplies (that is, +12V and -7V), making them ideal for long networks where induced voltages are a realistic concern. Each RS-485, RS-422 port includes a single receiver (RA), and the unused Rx output (RB) is disabled, but pulled high by an internal current source. The internal current source turns off in SHDN.

Worst case receiver input currents are 20% lower than the 1 “unit load” (1mA) RS-485 limit, which translates to a 15k Ω minimum input resistance.

These receivers include a “full fail-safe” function that ensures a high level receiver output if the receiver inputs are unconnected (floating), shorted together, or if the bus is terminated but undriven (that is, differential voltage collapses to near zero due to termination). Fail-safe with shorted, or terminated and undriven inputs is accomplished by setting the Rx upper switching point at -40mV, thereby ensuring that the Rx recognizes a 0V differential as a high level.

All the Rx outputs are short-circuit protected, and are tri-state when the IC is forced into SHDN, but ISL81334 (SOIC and SSOP) receiver outputs are not independently tri-statable. ISL41334 (QFN) receiver outputs are tri-statable via an active low RXEN input for each port (see [“ISL41334 \(QFN Package\) Special Features” on page 20](#) for more details).

Tx Features

The RS-485 and RS-422 driver is a differential output device that delivers at least 2.2V across a 54Ω load (RS-485), and at least 2.5V across a 100Ω load (RS-422). Both levels significantly exceed the standards requirements, and these exceptional output voltages increase system noise immunity, and/or allow for transmission over longer distances. The drivers feature low propagation delay skew to maximize bit widths, and to minimize EMI.

To allow multiple drivers on a bus, the RS-485 spec requires that drivers survive worst case bus contentions undamaged. ISL81334 and ISL41334 drivers meet this requirement through driver output short-circuit current limits, and on-chip thermal shutdown circuitry. The output stages incorporate current limiting circuitry that ensures that the output current never exceeds the RS-485 specification, even at the common-mode voltage range extremes. In the event of a major short-circuit condition, devices also include a thermal shutdown feature that disables the drivers whenever the die temperature becomes excessive. This eliminates the power dissipation, allowing the die to cool. The drivers automatically re-enable after the die temperature drops about 15°. If the contention persists, the thermal shutdown/re-enable cycle repeats until the fault is cleared. Receivers stay operational during thermal shutdown.

RS-485 multi-driver operation also requires drivers to include tri-state functionality, so each port has a DE pin to control this function. If the driver is used in an RS-422 network, such that driver tri-state is not required, then the DE pin can be left unconnected and an internal pull-up keeps it in the enabled state. Drivers are also tri-stated when the IC is in SHDN, or when the 5V power supply is off.

Speed Options

The ISL81334 (SOIC, SSOP) has fixed, high slew rate driver outputs optimized for 20Mbps data rates. The ISL41334 (QFN) offers three user selectable data rate options: “Fast” for high slew rate and 20Mbps, “Medium” with slew rate limiting set for 460kbps, and “Slow” with even more slew rate limiting for 115kbps operation. See [“Data Rate, Cables, and Terminations” on page 19](#) and [“RS-485 Slew Rate Limited Data Rates” on page 21](#) for more information.

Receiver performance is the same for all three speed options.

Data Rate, Cables, and Terminations

RS-485, RS-422 are intended for network lengths up to 4000' (1220m), but the maximum system data rate decreases as the transmission length increases. Devices operating at the maximum data rate of 20Mbps are limited to lengths of 20' to 30' (6m to 9m), while devices operating at or below 115kbps can operate at the maximum length of 4000' (1220m).

Higher data rates require faster edges, so both ISL81334 and ISL41334 versions offer an edge rate capable of 20Mbps data rates. The ISL41334 also offers two slew rate limited edge rates to minimize problems at slower data rates. Nevertheless, for the best jitter performance when driving long cables, the faster speed settings may be preferable, even at low data rates. See [“RS-485 Slew Rate Limited Data Rates” on page 21](#) for details.

Twisted pair is the cable of choice for RS-485/RS-422 networks. Twisted pair cables tend to pick up noise and other electromagnetically induced voltages as common-mode signals, which are effectively rejected by the differential receivers in these ICs.

The preferred cable connection technique is “daisy-chaining”, in which the cable runs from the connector of one device directly to the connector of the next device, such that cable stub lengths are negligible. A “backbone” structure, where stubs run from the main backbone cable to each device’s connector, is the next best choice, but care must be taken to ensure that each stub is electrically “short”. See [Table 4](#) for recommended maximum stub lengths for each speed option.

TABLE 4. RECOMMENDED STUB LENGTHS

SPEED OPTION	MAXIMUM STUB LENGTH ft (m)
SLOW	350 to 500 (107 to 152)
MED	100 to 150 (30.5 to 46)
FAST	1 to 3 (0.3 to 0.9)

Proper termination is imperative to minimize reflections when using the 20Mbps speed option. Short networks using the medium and slow speed options need not be terminated, but terminations are recommended unless power dissipation is an overriding concern. Note that the RS-485 specification allows a maximum of two terminations on a network, otherwise the Tx output voltage may not meet the required V_{OD} .

In point-to-point, or point-to-multipoint (RS-422) networks, the main cable should be terminated in its characteristic impedance (typically 120Ω) at the end farthest from the driver. In multi-receiver applications, stubs connecting receivers to the main cable should be kept as short as possible, but definitely shorter than the limits shown in [Table 4](#). Multipoint (RS-485) systems require that the main cable be terminated in its characteristic impedance at both ends. Again, keep stubs connecting a transceiver to the main cable as short as possible, and refer to [Table 4](#). Avoid “star”, and other configurations, that have many “ends”, which would require more than the two allowed terminations to prevent reflections.

High ESD

All pins on ISL81334 and ISL41334 include ESD protection structures rated at ±4kV (HBM), which is good enough to survive ESD events commonly seen during manufacturing. However, the bus pins (Tx outputs and Rx inputs) are particularly vulnerable to ESD events because they connect to an exposed port on the exterior of the finished product. Simply touching the port pins, or connecting a cable, can destroy an unprotected port. ISL81334 and ISL41334 bus pins are fitted with advanced structures that deliver ESD protection in excess of ±15kV (HBM), without interfering with any signal in the RS-485 or the RS-232 range. This high level of protection may eliminate the need for board level protection, or at the very least will increase the robustness of any board level scheme.

Small Packages

Many competing dual protocol ICs are available only in excessively large 24 to 28 Ld SOIC packages. The ISL81334's 28 Ld SSOP is 50% smaller than even a 24 Ld SOIC, and the ISL41334's tiny 6mmx6mm QFN is 80% smaller than a 28 Ld SOIC.

Flow Through Pinouts

Even the ISL81334 and ISL41334 pinouts are features, in that the "flow-through" design simplifies board layout. Having the bus pins all on one side of the package for easy routing to a cable connector, and the Rx outputs and Tx inputs on the other side for easy connection to a UART, avoids costly and problematic crossovers. [Figure 19](#) illustrates the flow-through nature of the pinout.

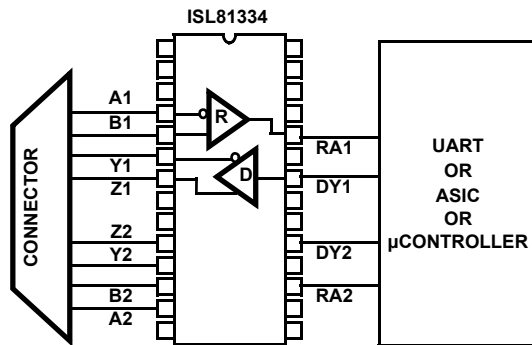

FIGURE 19. ILLUSTRATION OF FLOW THROUGH PINOUT

Low Power Shutdown (SHDN) Mode

The ON/ $\overline{\text{OFF}}$ pin is driven low to place the IC (both ports) in the SHDN mode, and the already low supply current drops to as low as 25 μA . If this functionality is not desired, the pin can be left disconnected (thanks to the internal pull-up), or it can be connected to V_{CC} (V_{L} for the QFN), through a 1k Ω resistor. SHDN disables the Tx and Rx outputs, and disables the charge pumps if either port is in RS-232 mode, so V_{+} collapses to V_{CC} , and V_{-} collapses to GND.

All but 5 μA of SHDN I_{CC} current is due to control input (ON, $\overline{\text{LB}}$, SP, DE) pull-up resistors ($\sim 20\mu\text{A}/\text{resistor}$), so SHDN I_{CC} varies depending on the ISL81334 and ISL41334 configuration. The specification tables indicate the worst case values, but careful selection of the configuration yields lower currents. For example, in RS-232 mode the SP pins are not used, so if both ports are configured for RS-232, floating or tying the SP pins high minimizes SHDN I_{CC} . Likewise in RS-485 mode, the drivers are disabled in SHDN, so driving the DE pins high during this time also reduces I_{CC} .

On the ISL41334, the SHDN I_{CC} increases as V_{L} decreases. V_{L} powers the input stage and sets its V_{OH} at V_{L} rather than V_{CC} . V_{CC} powers the second stage, but the second stage input is not driven to the rail, so some I_{CC} current flows. See [Figure 29 on page 23](#) for details.

When enabling from SHDN in RS-232 mode, allow at least 20 μs for the charge pumps to stabilize before transmitting data. The charge pumps are not used in RS-485 mode, so the transceiver is ready to send or receive data in less than 1 μs , which is much

faster than competing devices that require the charge pump for all modes of operation.

Internal Loopback Mode

Driving the $\overline{\text{LB}}$ pin low (ISL81334), or the $\overline{\text{LB}}$ pin and the $\overline{\text{RXEN}}$ pin low (ISL41334), places both ports in the loopback mode, a mode that facilitates implementing board level self-test functions. In loopback, internal switches disconnect the Rx inputs from the Rx outputs, and feed back the Tx outputs to the appropriate Rx output. This way the data driven at the Tx input appears at the corresponding Rx output (refer to "[Typical Operating Circuits](#)" on [pages 8](#) and [9](#)). The Tx outputs remain connected to their terminals, so the external loads are reflected in the loopback performance. This allows the loopback function to potentially detect some common bus faults such as one or both driver outputs shorted to GND, or outputs shorted together.

Note that the loopback mode uses an additional set of receivers, as shown in "[Typical Operating Circuits](#)" on [pages 8](#) and [9](#). These loopback receivers are not standards compliant, so the loopback mode cannot be used to implement a half-duplex RS-485 transceiver.

If loopback is not used, the pin can be left disconnected (thanks to the internal pull-up), or it should be connected to V_{CC} (V_{L} for the QFN), through a 1k Ω resistor.

ISL41334 (QFN Package) Special Features

Logic Supply (V_{L} Pin)

The ISL41334 (QFN) includes a V_{L} pin that powers the logic inputs (Tx inputs and control pins) and Rx outputs. These pins interface with "logic" devices such as UARTs, ASICs, and microcontrollers, and today most of these devices use power supplies significantly lower than 5V. Thus, a 5V output level from a 5V powered dual protocol IC might seriously overdrive and damage the logic device input. Similarly, the logic device's low V_{OH} might not exceed the V_{IH} of a 5V powered dual protocol input. Connecting the V_{L} pin to the power supply of the logic device (as shown in [Figure 20 on page 21](#)) limits the ISL41334's Rx output V_{OH} to V_{L} (see [Figure 23 on page 22](#)), and reduces the Tx and control input switching points to values compatible with the logic device output levels. Tailoring the logic pin input switching points and output levels to the supply voltage of the UART, ASIC, or microcontroller eliminates the need for a level shifter/translator between the two ICs.

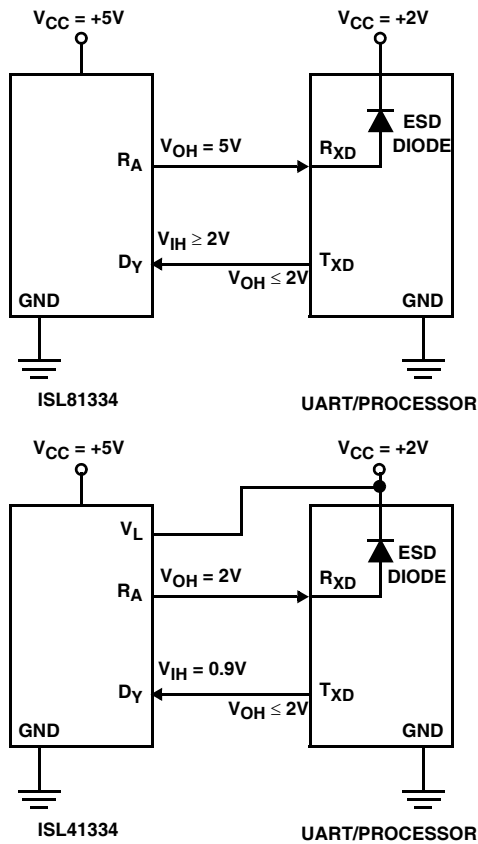

FIGURE 20. USING V_L PIN TO ADJUST LOGIC LEVELS

V_L can be anywhere from V_{CC} down to 1.65V, but the input switching points may not provide enough noise margin when $V_L < 1.8V$. Table 5 indicates typical V_{IH} and V_{IL} values for various V_L values so users can ascertain whether or not a particular V_L voltage meets their needs.

TABLE 5. V_{IH} AND V_{IL} vs V_L FOR $V_{CC} = 5V$

V_L (V)	V_{IH} (V)	V_{IL} (V)
1.65V	0.79	0.50
1.8V	0.82	0.60
2.0V	0.87	0.69
2.5V	0.99	0.86
3.3V	1.19	1.05

The V_L supply current (I_L) is typically less than $100\mu A$, as shown in Figures 28 and 29. All of the DC V_L current is due to inputs with internal pull-up resistors (DE, SP, LB, ON/OFF) being driven to the low input state. The worst case I_L current occurs during SHDN (see Figure 28), due to the I_L through the ON/OFF pin pull-up resistor when that pin is driven low. I_L through an input pull-up resistor is $\sim 20\mu A$, so the I_L in Figure 28 drops by about $40\mu A$ (at $V_L = 5V$) when the two SP inputs are high (middle vs top curve). I_L is lowest in the RS-232 mode, because only the ON/OFF pin should be driven low. When all these inputs are driven high, I_L drops to $< 1\mu A$, so to minimize power dissipation drive these inputs high when

unneded (SP inputs are not used in RS-232 mode, so drive them high).

Active Low Rx Enable (RXEN)

In many RS-485 applications, especially half duplex configurations, users like to accomplish “echo cancellation” by disabling the corresponding receiver while its driver is transmitting data. This function is available on the QFN package via an active low RXEN pin for each port. The active low function also simplifies direction control, by allowing a single Tx/Rx direction control line. If an active high RXEN were used, either two valuable I/O pins would be used for direction control, or an external inverter is required between DE and RXEN. Figure 21 details the advantage of using the RXEN pin.

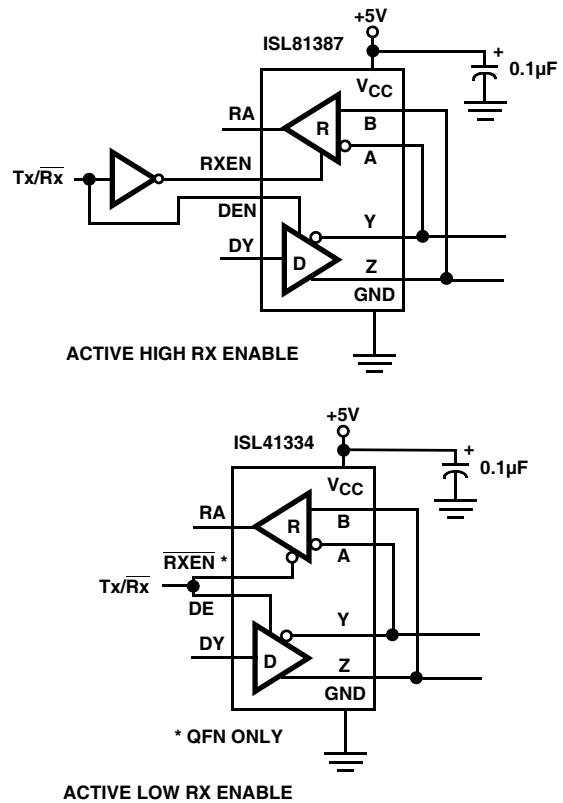

FIGURE 21. USING ACTIVE LOW vs ACTIVE HIGH RX ENABLE

RS-485 Slew Rate Limited Data Rates

The SOIC and SSOP versions of this IC operate with Tx output transitions optimized for a 20Mbps data rate. These fast edges may increase EMI and reflection issues, even though fast transitions are not required at the lower data rates used by many applications. The ISL41334 (QFN version) solves this problem by offering two additional, slew rate limited, data rates that are optimized for speeds of 115kbps, and 460kbps. The slew limited edges permit longer unterminated networks, or longer stubs off terminated busses, and help minimize EMI and reflections. Nevertheless, for the best jitter performance when driving long cables, the faster speed options may be preferable, even at lower data rates. The faster output transitions deliver less variability (jitter) when loaded with the large capacitance associated with long cables.

Figures 51, 52, and 53 detail the jitter performance of the three speed options while driving three different cable lengths. The figures show that under all conditions the faster the edge rate, the better the jitter performance. Of course, faster transitions require more attention to ensuring short stub lengths, and quality terminations, so there are trade-offs to be made. Assuming a jitter budget of 10%, it is likely better to go with the slow speed option for data rates of 115kbps or less to minimize fast edge effects. Likewise, the medium speed option is a good choice for data rates between 115kbps and 460kbps. For higher data rates, or when the absolute best jitter is required, use the high speed option.

Speed selection is via the SPA and SPB pins (see Table 3 on page 7), and the selection pertains to each port programmed for RS-485 mode.

Evaluation Board

An evaluation board, part number ISL41334EVAL1Z, is available to assist in assessing the dual protocol IC's performance. The evaluation board contains a QFN packaged device, but because the same die is used in all packages, the board is also useful for evaluating the functionality of the other versions. The board's design allows for evaluation of all standard features, plus the QFN-specific features. Refer to the eval board application note for details, and contact your sales representative for ordering information.

Typical Performance Curves

$V_{CC} = V_L = 5V, T_A = +25^\circ C$; unless otherwise specified.

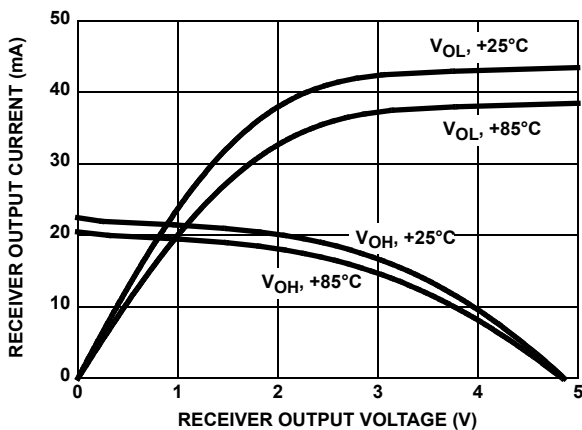

FIGURE 22. RECEIVER OUTPUT CURRENT vs RECEIVER OUTPUT VOLTAGE

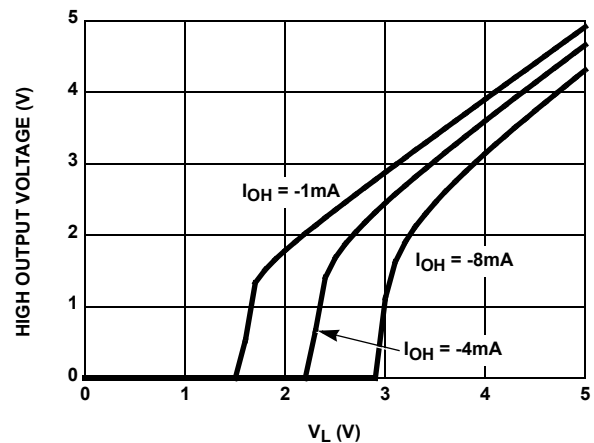

FIGURE 23. RECEIVER HIGH OUTPUT VOLTAGE vs LOGIC SUPPLY VOLTAGE (V_L)

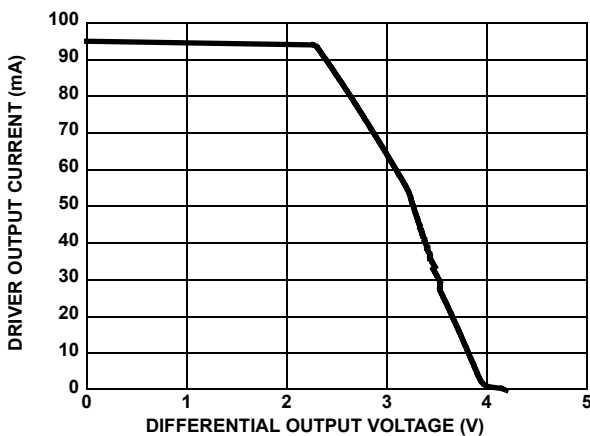

FIGURE 24. RS-485, DRIVER OUTPUT CURRENT vs DIFFERENTIAL OUTPUT VOLTAGE

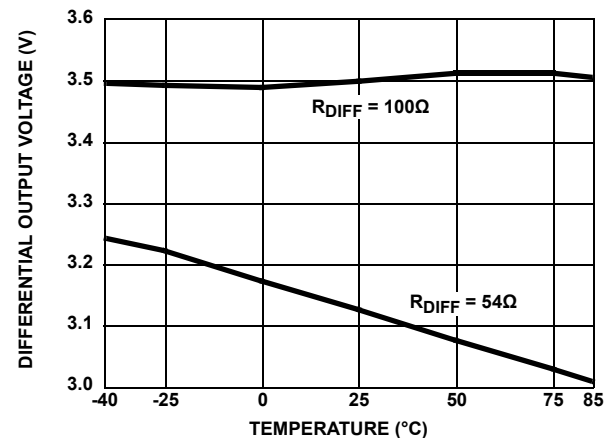

FIGURE 25. RS-485, DRIVER DIFFERENTIAL OUTPUT VOLTAGE vs TEMPERATURE

Typical Performance Curves $V_{CC} = V_L = 5V, T_A = +25^\circ C$; unless otherwise specified. (Continued)

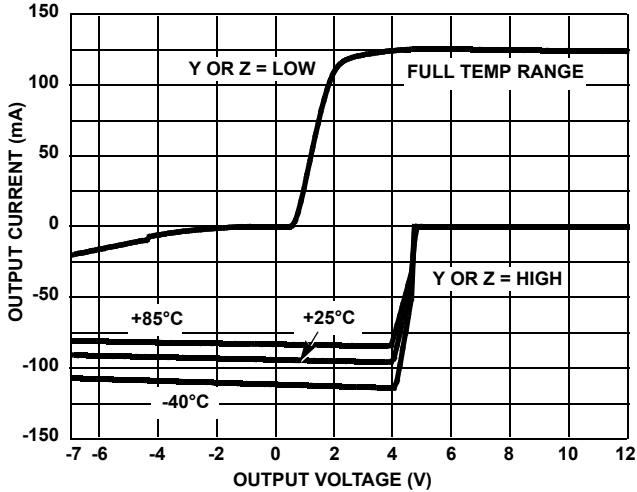

FIGURE 26. RS-485, DRIVER OUTPUT CURRENT vs SHORT-CIRCUIT VOLTAGE

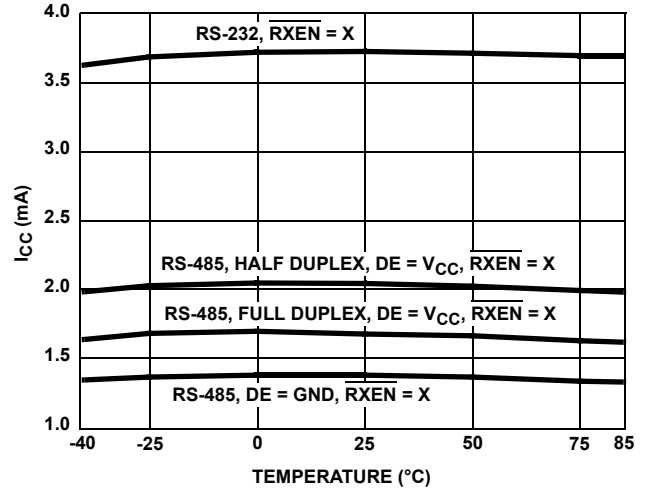

FIGURE 27. SUPPLY CURRENT vs TEMPERATURE

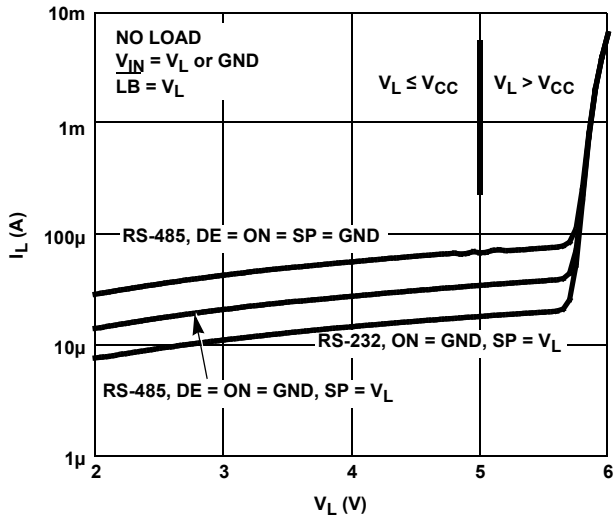

FIGURE 28. RS-232, V_L SUPPLY CURRENT vs V_L VOLTAGE (QFN ONLY)

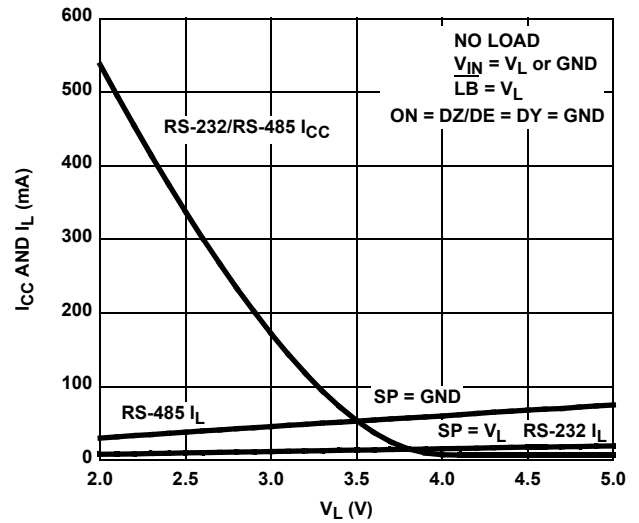

FIGURE 29. V_{CC} and V_L SHDN SUPPLY CURRENTS vs V_L VOLTAGE (QFN ONLY)

Typical Performance Curves $V_{CC} = V_L = 5V, T_A = +25^\circ C$; unless otherwise specified. (Continued)

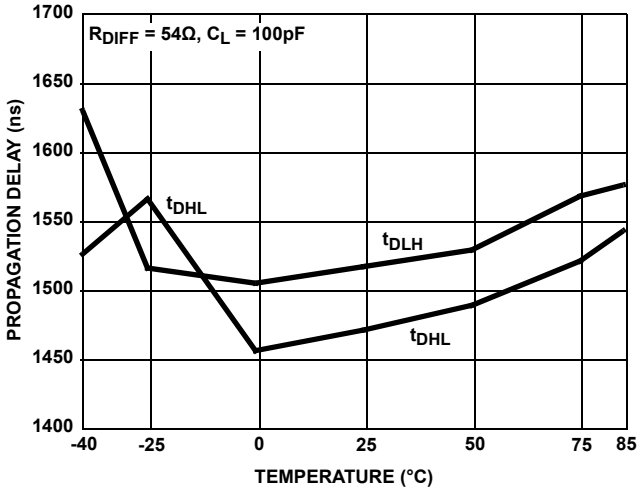

FIGURE 30. RS-485, DRIVER PROPAGATION DELAY vs TEMPERATURE (SLOW DATA RATE, QFN ONLY)

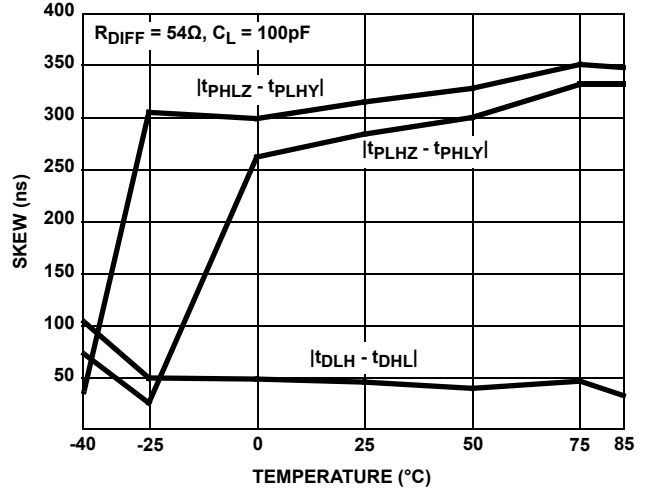

FIGURE 31. RS-485, DRIVER SKEW vs TEMPERATURE (SLOW DATA RATE, QFN ONLY)

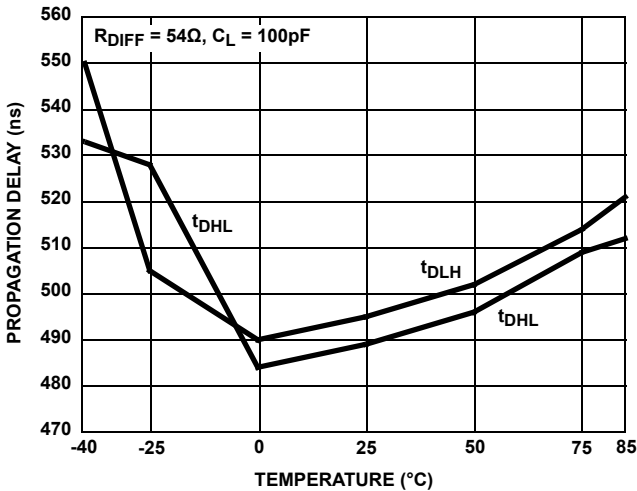

FIGURE 32. RS-485, DRIVER PROPAGATION DELAY vs TEMPERATURE (MEDIUM DATA RATE, QFN ONLY)

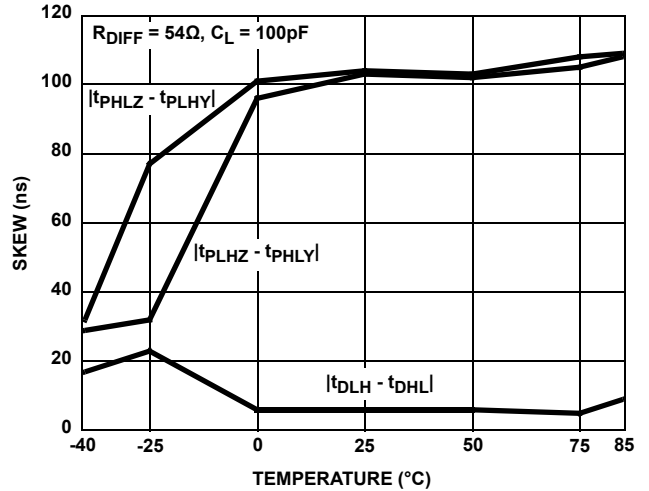

FIGURE 33. RS-485, DRIVER SKEW vs TEMPERATURE (MEDIUM DATA RATE, QFN ONLY)

Typical Performance Curves

$V_{CC} = V_L = 5V$, $T_A = +25^\circ C$; unless otherwise specified. (Continued)

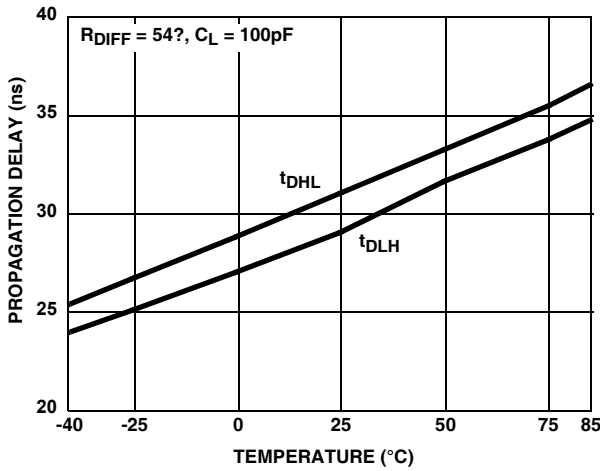

FIGURE 34. RS-485, DRIVER PROPAGATION DELAY vs TEMPERATURE (FAST DATA RATE)

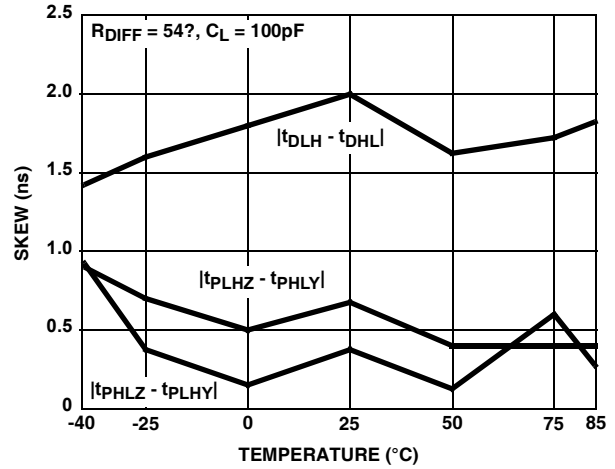

FIGURE 35. RS-485, DRIVER SKEW vs TEMPERATURE (FAST DATA RATE)

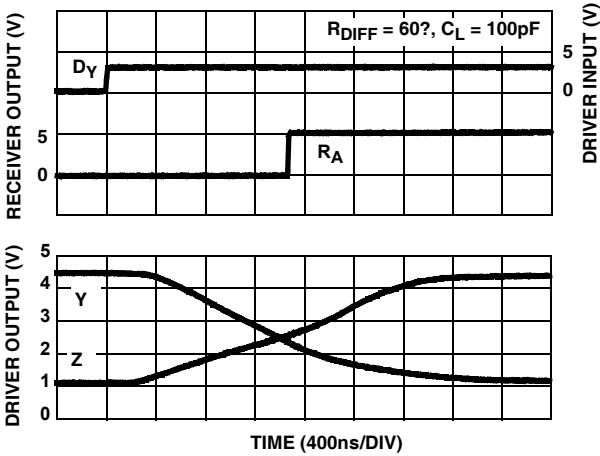

FIGURE 36. RS-485, DRIVER AND RECEIVER WAVEFORMS, LOW TO HIGH (SLOW DATA RATE, QFN ONLY)

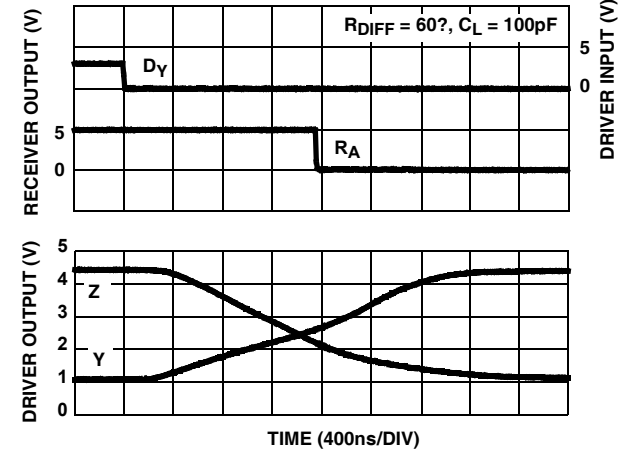

FIGURE 37. RS-485, DRIVER AND RECEIVER WAVEFORMS, HIGH TO LOW (SLOW DATA RATE, QFN ONLY)

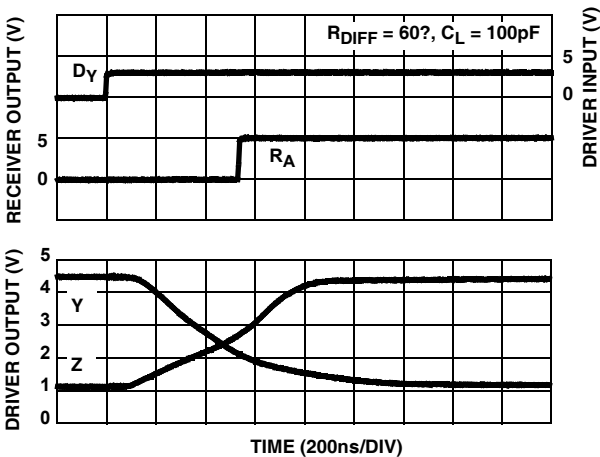

FIGURE 38. RS-485, DRIVER AND RECEIVER WAVEFORMS, LOW TO HIGH (MEDIUM DATA RATE, QFN ONLY)

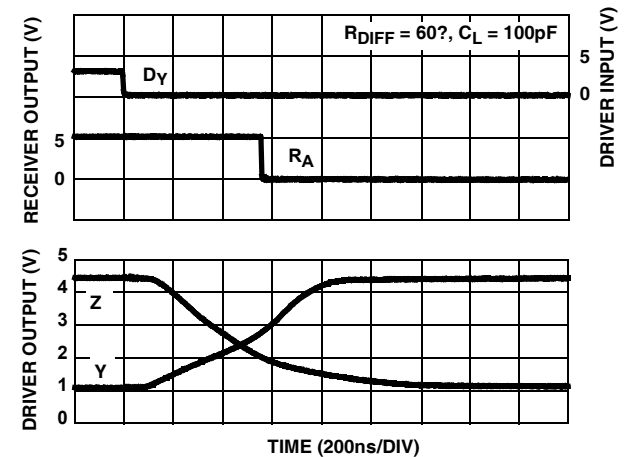

FIGURE 39. RS-485, DRIVER AND RECEIVER WAVEFORMS, HIGH TO LOW (MEDIUM DATA RATE, QFN ONLY)

Typical Performance Curves

$V_{CC} = V_L = 5V, T_A = +25^\circ C$; unless otherwise specified. (Continued)

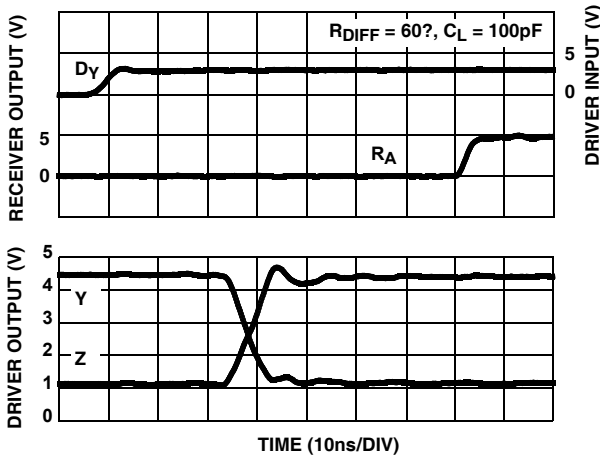

FIGURE 40. RS-485, DRIVER AND RECEIVER WAVEFORMS, LOW TO HIGH (FAST DATA RATE)

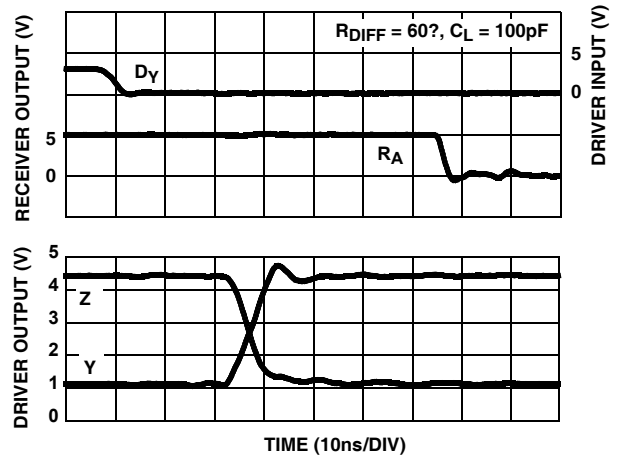

FIGURE 41. RS-485, DRIVER AND RECEIVER WAVEFORMS, HIGH TO LOW (FAST DATA RATE)

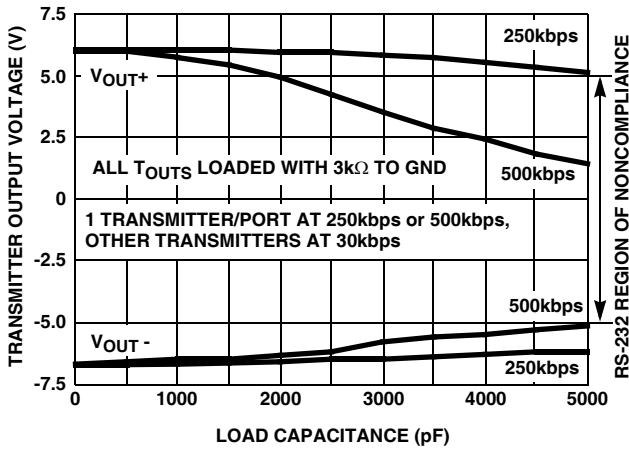

FIGURE 42. RS-232, TRANSMITTER OUTPUT VOLTAGE vs LOAD CAPACITANCE

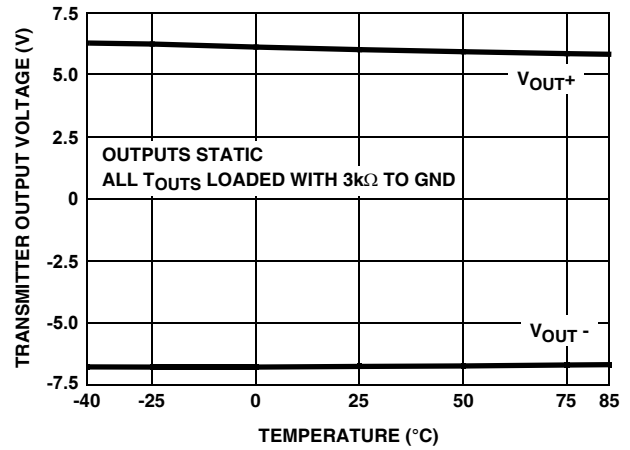

FIGURE 43. RS-232, TRANSMITTER OUTPUT VOLTAGE vs TEMPERATURE

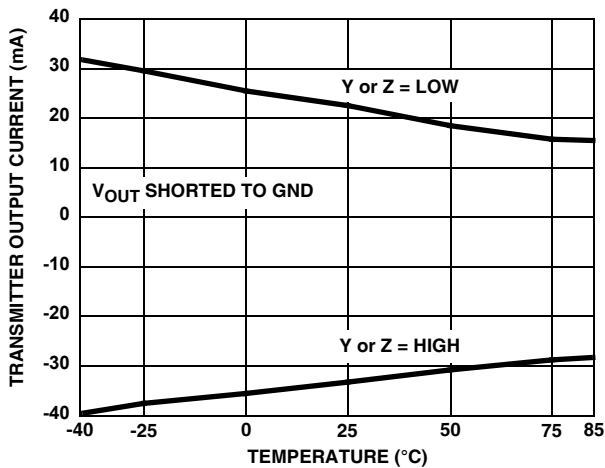

FIGURE 44. RS-232, TRANSMITTER SHORT-CIRCUIT CURRENT vs TEMPERATURE

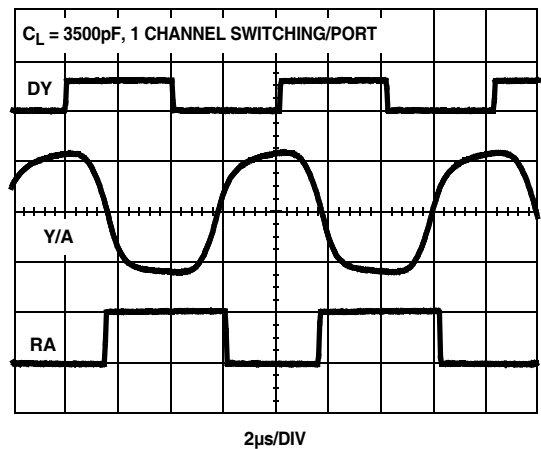

FIGURE 45. RS-232, TRANSMITTER AND RECEIVER WAVEFORMS AT 250kbps

Typical Performance Curves $V_{CC} = V_L = 5V, T_A = +25^\circ C$; unless otherwise specified. (Continued)

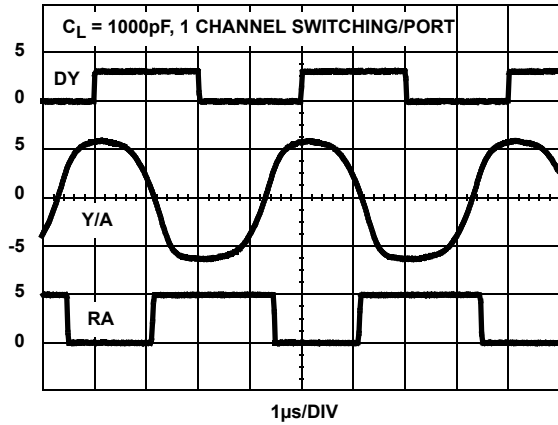

FIGURE 46. RS-232, TRANSMITTER AND RECEIVER WAVEFORMS AT 500kbps

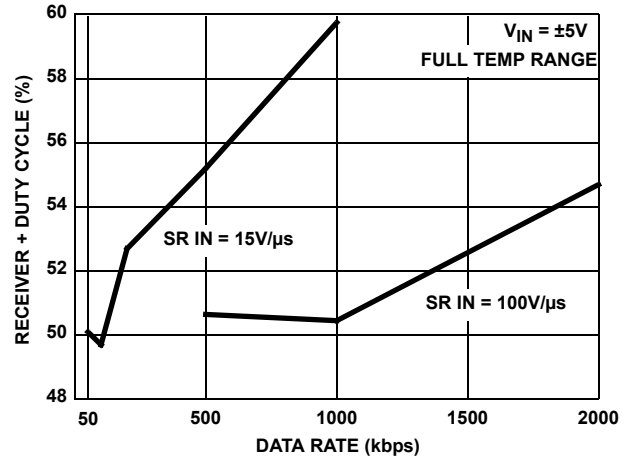

FIGURE 47. RS-232, RECEIVER OUTPUT + DUTY CYCLE vs DATA RATE

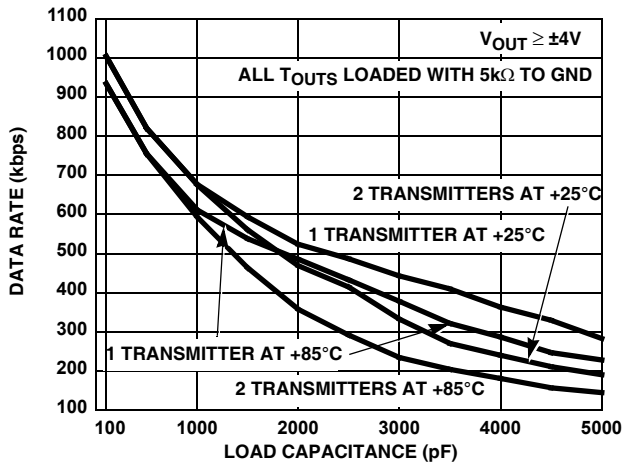

FIGURE 48. RS-232, TRANSMITTER MAXIMUM DATA RATE vs LOAD CAPACITANCE

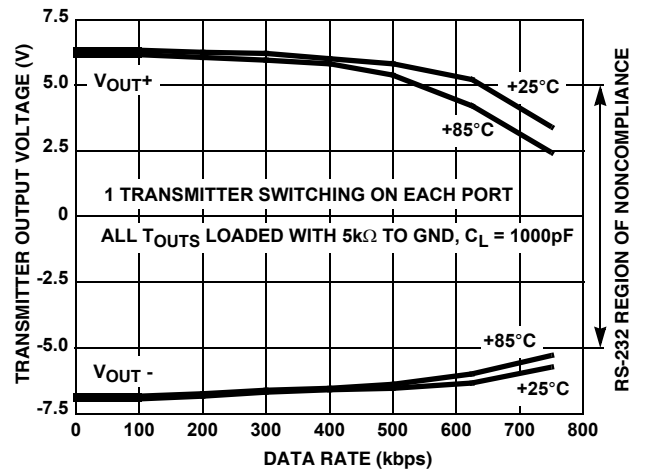

FIGURE 49. RS-232, TRANSMITTER OUTPUT VOLTAGE vs DATA RATE

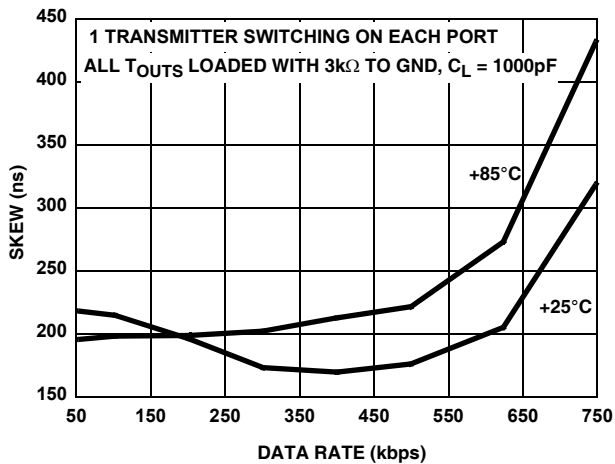

FIGURE 50. RS-232, TRANSMITTER SKEW vs DATA RATE

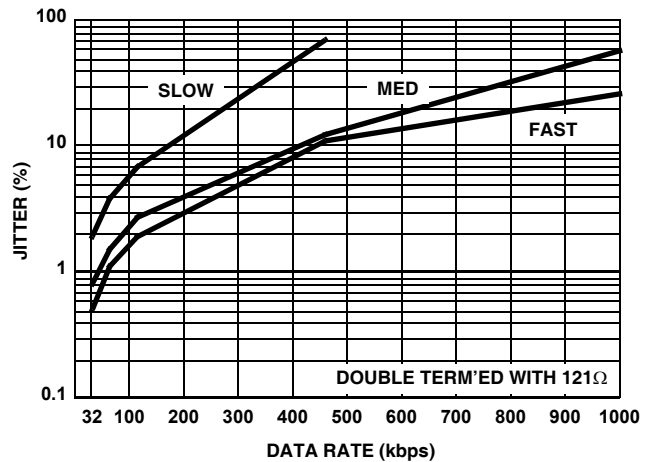

FIGURE 51. RS-485, TRANSMITTER JITTER vs DATA RATE WITH 2000' CAT-5 CABLE

Typical Performance Curves

$V_{CC} = V_L = 5V$, $T_A = +25^\circ C$; unless otherwise specified. (Continued)

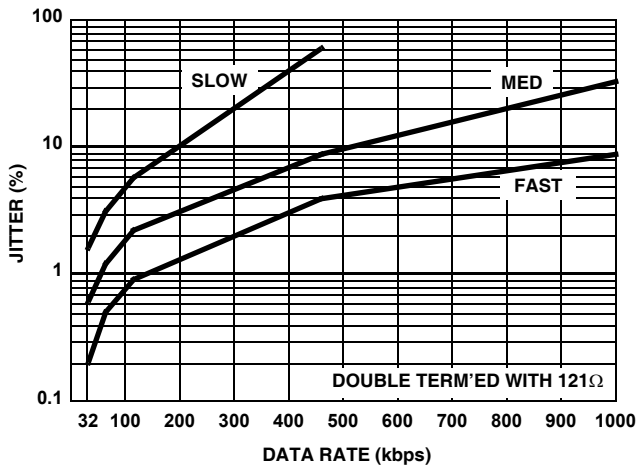

FIGURE 52. RS-485, TRANSMITTER JITTER vs DATA RATE WITH 1000' CAT-5 CABLE

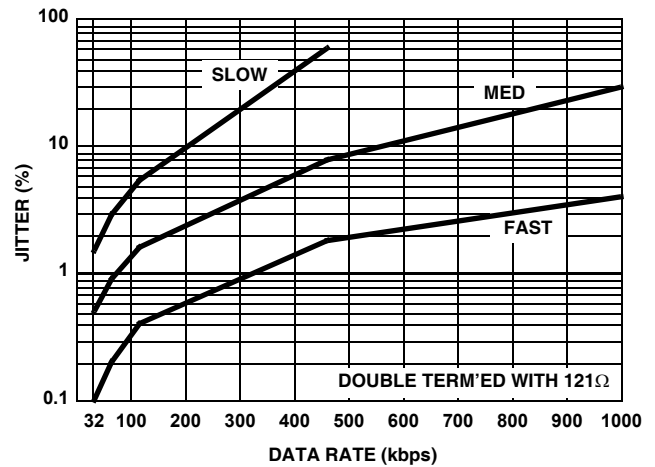

FIGURE 53. RS-485, TRANSMITTER JITTER vs DATA RATE WITH 350' CAT-5 CABLE

Die Characteristics

SUBSTRATE AND QFN THERMAL PAD POTENTIAL (POWERED UP)

GND

TRANSISTOR COUNT

4838

PROCESS

BiCMOS

Revision History The revision history provided is for informational purposes only and is believed to be accurate, but not warranted. Please visit our website to make sure you have the latest revision.

DATE	REVISION	CHANGE
Mar 24, 2017	FN6202.4	<p>Updated entire datasheet applying new standards.</p> <p>Added Related Literature section.</p> <p>Updated ordering information table - added evaluation board, updated Notes 1 and 2, and added Tape and reel quantity, added Note 3.</p> <p>Updated Pin \overline{LB} description on 4.</p> <p>Added Notes 5 and 8.</p> <p>Updated Figures 1 through 4.</p> <p>Added Figures 5 through 8.</p> <p>Updated first sentence in "Internal Loopback Mode" on page 20 to add clarification.</p> <p>Added Revision History and About Intersil sections.</p> <p>Updated POD M28.3 to the latest revision. Changes were as follows:</p> <ul style="list-style-type: none"> -Added land pattern

About Intersil

Intersil Corporation is a leading provider of innovative power management and precision analog solutions. The company's products address some of the largest markets within the industrial and infrastructure, mobile computing, and high-end consumer markets. For the most updated datasheet, application notes, related documentation, and related parts, see the respective product information page found at www.intersil.com.

For a listing of definitions and abbreviations of common terms used in our documents, visit www.intersil.com/glossary.

You can report errors or suggestions for improving this datasheet by visiting www.intersil.com/ask.

Reliability reports are also available from our website at www.intersil.com/support.

© Copyright Intersil Americas LLC 2005-2017. All Rights Reserved.
All trademarks and registered trademarks are the property of their respective owners.

For additional products, see www.intersil.com/en/products.html

Intersil products are manufactured, assembled and tested utilizing ISO9001 quality systems as noted in the quality certifications found at www.intersil.com/en/support/qualandreliability.html

Intersil products are sold by description only. Intersil may modify the circuit design and/or specifications of products at any time without notice, provided that such modification does not, in Intersil's sole judgment, affect the form, fit or function of the product. Accordingly, the reader is cautioned to verify that datasheets are current before placing orders. Information furnished by Intersil is believed to be accurate and reliable. However, no responsibility is assumed by Intersil or its subsidiaries for its use; nor for any infringements of patents or other rights of third parties which may result from its use. No license is granted by implication or otherwise under any patent or patent rights of Intersil or its subsidiaries.

For information regarding Intersil Corporation and its products, see www.intersil.com

Package Outline Drawing

For the most recent package outline drawing, see [L40.6x6](#).

L40.6x6

40 LEAD QUAD FLAT NO-LEAD PLASTIC PACKAGE

Rev 3, 10/06

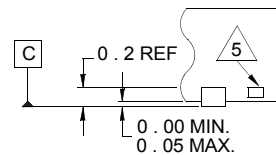
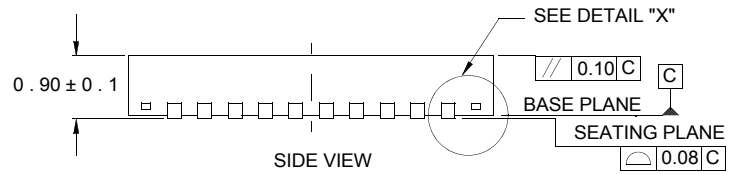
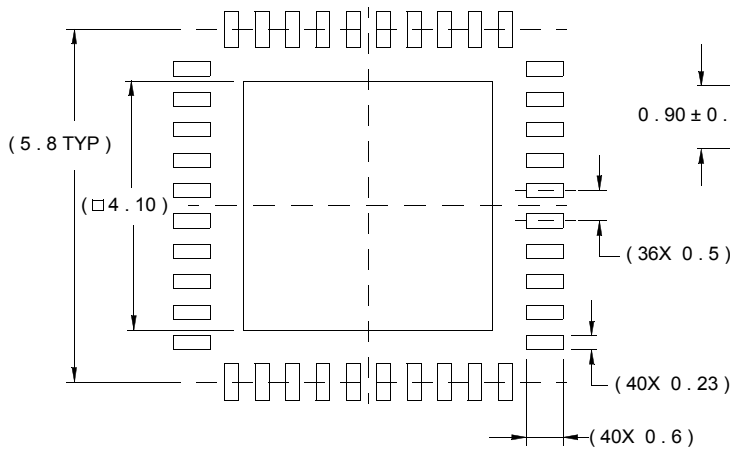
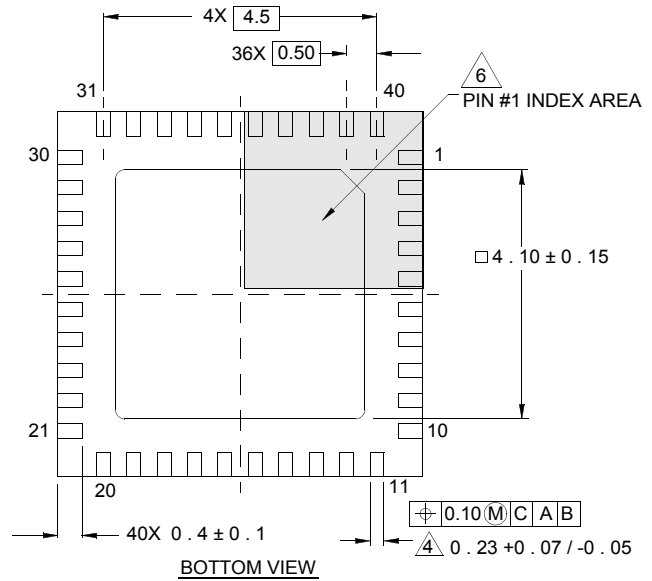
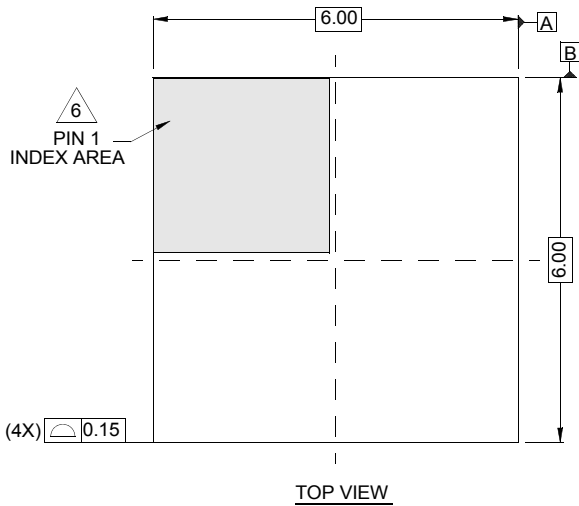

NOTES:

1. Dimensions are in millimeters.
Dimensions in () for Reference Only.
2. Dimensioning and tolerancing conform to AMSE Y14.5m-1994.
3. Unless otherwise specified, tolerance : Decimal ± 0.05
4. Dimension b applies to the metallized terminal and is measured between 0.15mm and 0.30mm from the terminal tip.
5. Tiebar shown (if present) is a non-functional feature.
6. The configuration of the pin #1 identifier is optional, but must be located within the zone indicated. The pin #1 identifier may be either a mold or mark feature.

Small Outline Plastic Packages (SOIC)

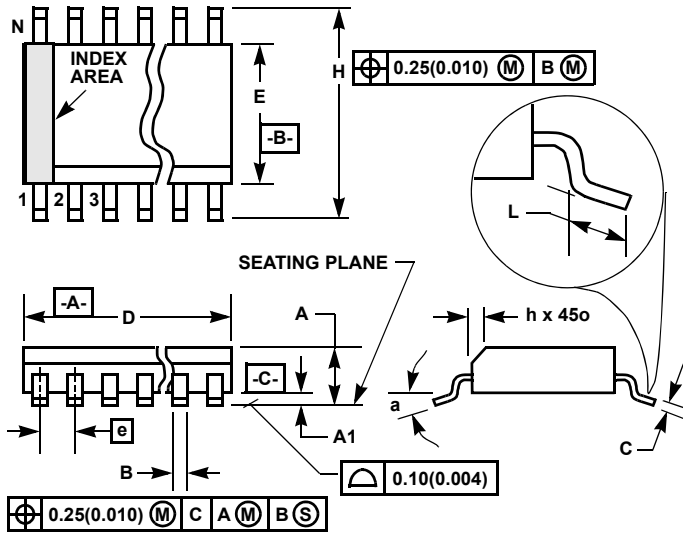

M28.3

(JEDEC MS-013-AE ISSUE C)

28 LEAD WIDE BODY SMALL OUTLINE PLASTIC PACKAGE

SYMBOL	INCHES		MILLIMETERS		NOTES
	MIN	MAX	MIN	MAX	
A	0.0926	0.1043	2.35	2.65	-
A1	0.0040	0.0118	0.10	0.30	-
B	0.013	0.0200	0.33	0.51	9
C	0.0091	0.0125	0.23	0.32	-
D	0.6969	0.7125	17.70	18.10	3
E	0.2914	0.2992	7.40	7.60	4
e	0.05 BSC		1.27 BSC		-
H	0.394	0.419	10.00	10.65	-
h	0.01	0.029	0.25	0.75	5
L	0.016	0.050	0.40	1.27	6
N	28		28		7
α	0°	8°	0°	8°	-

Rev. 1, 1/13

NOTES:

1. Symbols are defined in the "MO Series Symbol List" in Section 2.2 of Publication Number 95.
2. Dimensioning and tolerancing per ANSI Y14.5M-1982.
3. Dimension "D" does not include mold flash, protrusions or gate burrs. Mold flash, protrusion and gate burrs shall not exceed 0.15mm (0.006 inch) per side.
4. Dimension "E" does not include interlead flash or protrusions. Interlead flash and protrusions shall not exceed 0.25mm (0.010 inch) per side.
5. The chamfer on the body is optional. If it is not present, a visual index feature must be located within the crosshatched area.
6. "L" is the length of terminal for soldering to a substrate.
7. "N" is the number of terminal positions.
8. Terminal numbers are shown for reference only.
9. The lead width "B", as measured 0.36mm (0.014 inch) or greater above the seating plane, shall not exceed a maximum value of 0.61mm (0.024 inch)
10. Controlling dimension: MILLIMETER. Converted inch dimensions are not necessarily exact.

TYPICAL RECOMMENDED LAND PATTERN

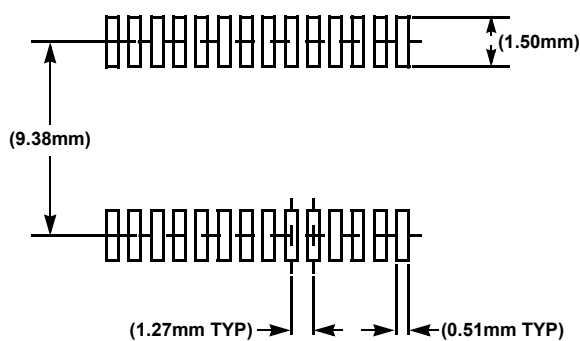

For the most recent package outline drawing, see [M28.3](#).

Shrink Small Outline Plastic Packages (SSOP)

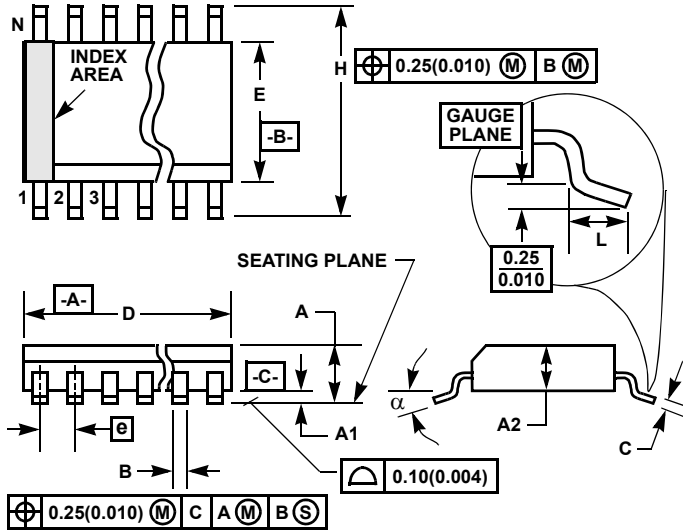

M28.209
(JEDEC MO-150-AH ISSUE B)
28 LEAD SHRINK SMALL OUTLINE PLASTIC PACKAGE

SYMBOL	INCHES		MILLIMETERS		NOTES
	MIN	MAX	MIN	MAX	
A	-	0.078	-	2.00	-
A1	0.002	-	0.05	-	-
A2	0.065	0.072	1.65	1.85	-
B	0.009	0.014	0.22	0.38	9
C	0.004	0.009	0.09	0.25	-
D	0.390	0.413	9.90	10.50	3
E	0.197	0.220	5.00	5.60	4
e	0.026 BSC		0.65 BSC		-
H	0.292	0.322	7.40	8.20	-
L	0.022	0.037	0.55	0.95	6
N	28		28		7
alpha	0°	8°	0°	8°	-

NOTES:

1. Symbols are defined in the "MO Series Symbol List" in Section 2.2 of Publication Number 95.
2. Dimensioning and tolerancing per ANSI Y14.5M-1982.
3. Dimension "D" does not include mold flash, protrusions or gate burrs. Mold flash, protrusion and gate burrs shall not exceed 0.20mm (0.0078 inch) per side.
4. Dimension "E" does not include interlead flash or protrusions. Interlead flash and protrusions shall not exceed 0.20mm (0.0078 inch) per side.
5. The chamfer on the body is optional. If it is not present, a visual index feature must be located within the crosshatched area.
6. "L" is the length of terminal for soldering to a substrate.
7. "N" is the number of terminal positions.
8. Terminal numbers are shown for reference only.
9. Dimension "B" does not include dambar protrusion. Allowable dambar protrusion shall be 0.13mm (0.005 inch) total in excess of "B" dimension at maximum material condition.
10. Controlling dimension: MILLIMETER. Converted inch dimensions are not necessarily exact.

Rev. 2 6/05

For the most recent package outline drawing, see [M28.209](#).

Looking for pricing, stock, or lifecycle information?

Click below to explore more details on WIN SOURCE:

 [View ISL81334IAZ on WIN SOURCE](#)

 [Intersil Information](#)

Optimize Your Supply Chain with WIN SOURCE Solutions

-  Global Sourcing Solution
-  Obsolete Management
-  Cost Control Management
-  Shortage Management
-  Alternative Solution
-  Excess Inventory Management