



**THE DATASHEET OF  
IS64LV25616AL-12TLA3-TR**



## 256K x 16 HIGH SPEED ASYNCHRONOUS CMOS STATIC RAM WITH 3.3V SUPPLY

JULY 2006

### FEATURES

- High-speed access time: 10, 12 ns
- CMOS low power operation
- Low stand-by power:  
Less than 5 mA (typ.) CMOS stand-by
- TTL compatible interface levels
- Single 3.3V power supply
- Fully static operation: no clock or refresh required
- Three state outputs
- Data control for upper and lower bytes
- Industrial temperature available
- Temperature Offerings:  
Option A1: -40°C to +85°C  
Option A2: -40°C to +105°C  
Option A3: -40°C to +125°C
- Lead-free available

### DESCRIPTION

The *ISSI* IS64LV25616AL is a high-speed, 4,194,304-bit static RAM organized as 262,144 words by 16 bits. It is fabricated using *ISSI*'s high-performance CMOS technology. This highly reliable process coupled with innovative circuit design techniques, yields high-performance and low power consumption devices.

When  $\overline{CE}$  is HIGH (deselected), the device assumes a standby mode at which the power dissipation can be reduced down with CMOS input levels.

Easy memory expansion is provided by using Chip Enable and Output Enable inputs,  $\overline{CE}$  and  $\overline{OE}$ . The active LOW Write Enable ( $\overline{WE}$ ) controls both writing and reading of the memory. A data byte allows Upper Byte ( $\overline{UB}$ ) and Lower Byte ( $\overline{LB}$ ) access.

The IS64LV25616AL is packaged in the JEDEC standard 44-pin TSOP Type II and 48-pin Mini BGA (8mm x 10mm).

### FUNCTIONAL BLOCK DIAGRAM

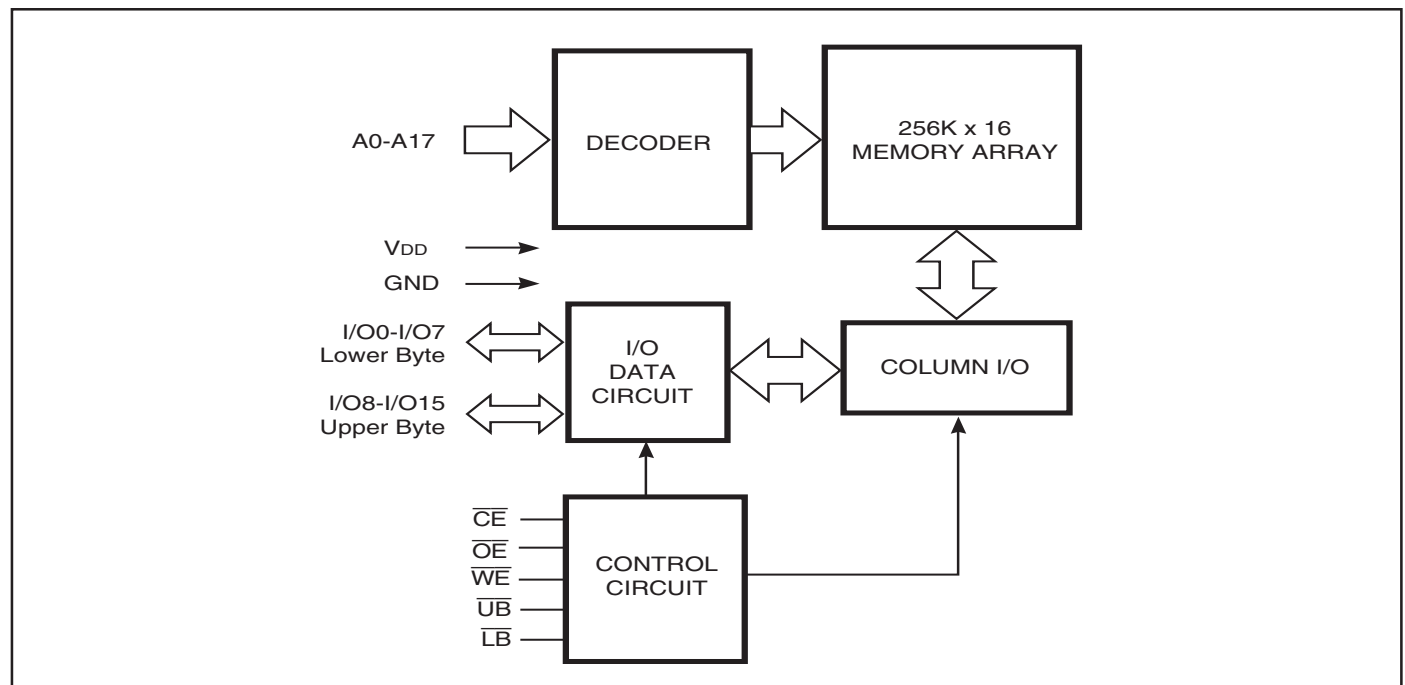

Copyright © 2006 Integrated Silicon Solution, Inc. All rights reserved. ISSI reserves the right to make changes to this specification and its products at any time without notice. ISSI assumes no liability arising out of the application or use of any information, products or services described herein. Customers are advised to obtain the latest version of this device specification before relying on any published information and before placing orders for products.

TRUTH TABLE

Mode	WE	CE	OE	LB	UB	I/O PIN		V <sub>DD</sub> Current
						I/O0-I/O7	I/O8-I/O15	
Not Selected	X	H	X	X	X	High-Z	High-Z	I <sub>SB1</sub> , I <sub>SB2</sub>
Output Disabled	H	L	H	X	X	High-Z	High-Z	I <sub>CC</sub>
	X	L	X	H	H	High-Z	High-Z	
Read	H	L	L	L	H	DOUT	High-Z	I <sub>CC</sub>
	H	L	L	H	L	High-Z	DOUT	
	H	L	L	L	L	DOUT	DOUT	
Write	L	L	X	L	H	DIN	High-Z	I <sub>CC</sub>
	L	L	X	H	L	High-Z	DIN	
	L	L	X	L	L	DIN	DIN	

PIN CONFIGURATIONS

44-Pin TSOP (Type II)

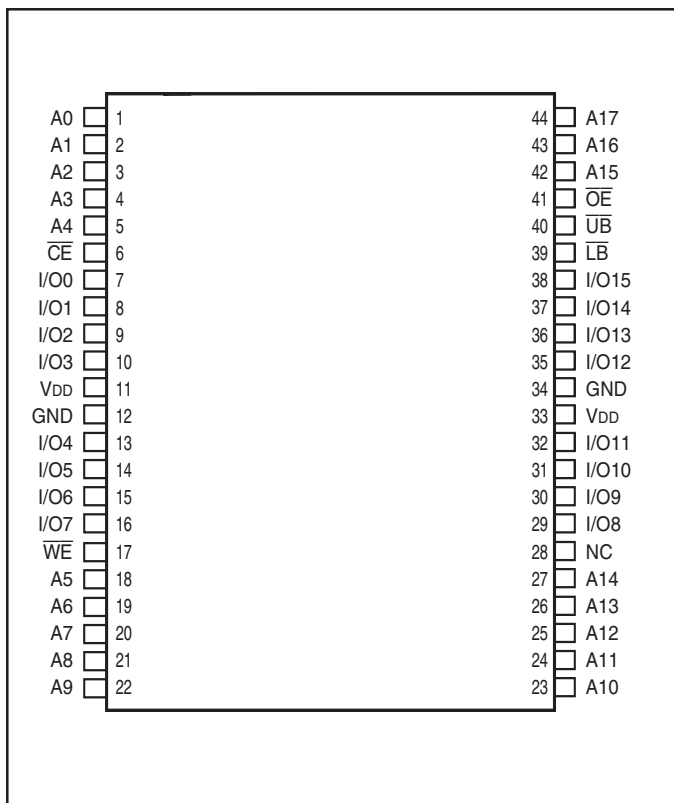

PIN DESCRIPTIONS

A0-A17	Address Inputs
I/O0-I/O15	Data Inputs/Outputs
CE	Chip Enable Input
OE	Output Enable Input
WE	Write Enable Input
LB	Lower-byte Control (I/O0-I/O7)
UB	Upper-byte Control (I/O8-I/O15)
NC	No Connection
V <sub>DD</sub>	Power
GND	Ground

**PIN CONFIGURATIONS**

**48-Pin mini BGA**

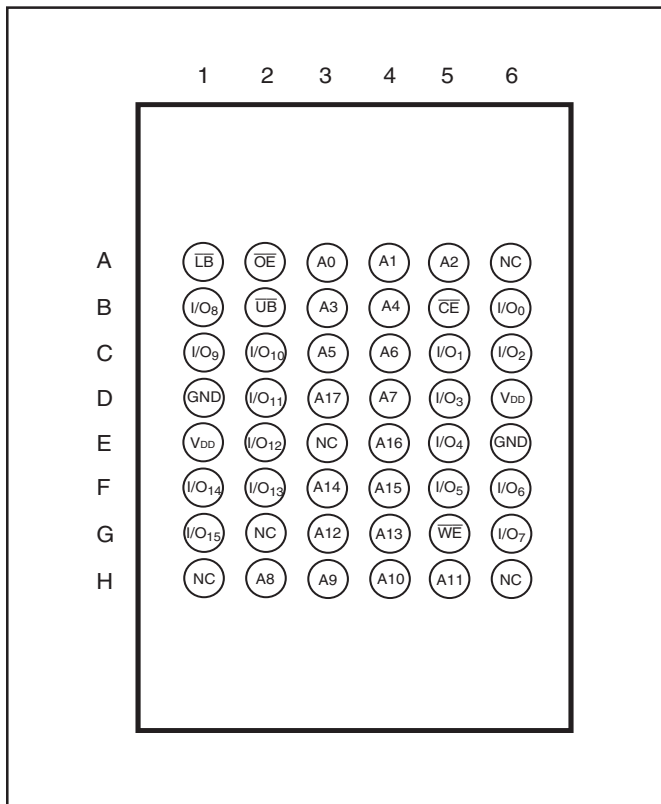

**PIN DESCRIPTIONS**

A0-A17	Address Inputs
I/O0-I/O15	Data Inputs/Outputs
$\overline{CE}$	Chip Enable Input
$\overline{OE}$	Output Enable Input
$\overline{WE}$	Write Enable Input
$\overline{LB}$	Lower-byte Control (I/O0-I/O7)
$\overline{UB}$	Upper-byte Control (I/O8-I/O15)
NC	No Connection
V <sub>DD</sub>	Power
GND	Ground

ABSOLUTE MAXIMUM RATINGS<sup>(1)</sup>

Symbol	Parameter	Value	Unit
V <sub>TERM</sub>	Terminal Voltage with Respect to GND	-0.5 to V <sub>DD</sub> +0.5	V
V <sub>DD</sub>	V <sub>DD</sub> Related to GND	-0.3 to +4.0	V
T <sub>STG</sub>	Storage Temperature	-65 to +150	°C
P <sub>T</sub>	Power Dissipation	1.0	W

**Note:**

1. Stress greater than those listed under ABSOLUTE MAXIMUM RATINGS may cause permanent damage to the device. This is a stress rating only and functional operation of the device at these or any other conditions above those indicated in the operational sections of this specification is not implied. Exposure to absolute maximum rating conditions for extended periods may affect reliability.

## OPERATING RANGE

Options	Ambient Temperature	V <sub>DD</sub>
A1	-40°C to +85°C	3.3V +10%, -5%
A2	-40°C to +105°C	3.3V +10%, -5%
A3	-40°C to +125°C	3.3V +10%, -5%

## DC ELECTRICAL CHARACTERISTICS (Over Operating Range)

Symbol	Parameter	Test Conditions	Options	Min.	Max.	Unit
V <sub>OH</sub>	Output HIGH Voltage	V <sub>DD</sub> = Min., I <sub>OH</sub> = -4.0 mA		2.4	—	V
V <sub>OL</sub>	Output LOW Voltage	V <sub>DD</sub> = Min., I <sub>OL</sub> = 8.0 mA		—	0.4	V
V <sub>IH</sub>	Input HIGH Voltage			2.0	V <sub>DD</sub> + 0.3	V
V <sub>IL</sub>	Input LOW Voltage <sup>(1)</sup>			-0.3	0.8	V
I <sub>LI</sub>	Input Leakage	GND ≤ V <sub>IN</sub> ≤ V <sub>DD</sub>	A1 A2 A3	-2 -5 -10	2 5 10	μA
I <sub>LO</sub>	Output Leakage	GND ≤ V <sub>OUT</sub> ≤ V <sub>DD</sub> , Outputs Disabled	A1 A2 A3	-2 -5 -10	2 5 10	μA

**Notes:**

1. V<sub>IL</sub> (min.) = -2.0V for pulse width less than 10 ns.

**POWER SUPPLY CHARACTERISTICS<sup>(1)</sup>** (Over Operating Range)

Symbol	Parameter	Test Conditions	Options	-10		-12		Unit
				Min.	Max.	Min.	Max.	
I <sub>CC</sub>	V <sub>DD</sub> Dynamic Operating Supply Current	V <sub>DD</sub> = Max., I <sub>OUT</sub> = 0 mA, f = f <sub>MAX</sub>	A1	—	100	—	—	mA
			A2	—	—	—	110	
			A3	—	—	—	120	
I <sub>SB</sub>	TTL Standby Current (TTL Inputs)	V <sub>DD</sub> = Max., V <sub>IN</sub> = V <sub>IH</sub> or V <sub>IL</sub> $\overline{CE} \geq V_{IH}$ , f = f <sub>MAX</sub> .	A1	—	50	—	—	mA
			A2	—	—	—	55	
			A3	—	—	—	60	
I <sub>SB1</sub>	TTL Standby Current (TTL Inputs)	V <sub>DD</sub> = Max., V <sub>IN</sub> = V <sub>IH</sub> or V <sub>IL</sub> $\overline{CE} \geq V_{IH}$ , f = 0	A1	—	20	—	—	mA
			A2	—	—	—	30	
			A3	—	—	—	40	
I <sub>SB2</sub>	CMOS Standby Current (CMOS Inputs)	V <sub>DD</sub> = Max., $\overline{CE} \geq V_{DD} - 0.2V$ , V <sub>IN</sub> ≥ V <sub>DD</sub> - 0.2V, or V <sub>IN</sub> ≤ 0.2V, f = 0	A1	—	15	—	—	mA
			A2	—	—	—	25	
			A3	—	—	—	35	
			typ <sup>(2)</sup>	—	5	—	5	

**Note:**

- At f = f<sub>MAX</sub>, address and data inputs are cycling at the maximum frequency, f = 0 means no input lines change. Shaded area product in development
- Typical values are measured at V<sub>DD</sub> = 3.3V, T<sub>A</sub> = 25°C and not 100% tested.

**CAPACITANCE<sup>(1)</sup>**

Symbol	Parameter	Conditions	Max.	Unit
C <sub>IN</sub>	Input Capacitance	V <sub>IN</sub> = 0V	6	pF
C <sub>OUT</sub>	Input/Output Capacitance	V <sub>OUT</sub> = 0V	8	pF

**Note:**

- Tested initially and after any design or process changes that may affect these parameters.

**READ CYCLE SWITCHING CHARACTERISTICS<sup>(1)</sup>** (Over Operating Range)

Symbol	Parameter	-10		-12		Unit
		Min.	Max.	Min.	Max.	
t <sub>RC</sub>	Read Cycle Time	10	—	12	—	ns
t <sub>AA</sub>	Address Access Time	—	10	—	12	ns
t <sub>OH</sub>	Output Hold Time	2	—	2	—	ns
t <sub>ACE</sub>	$\overline{CE}$ Access Time	—	10	—	12	ns
t <sub>DOE</sub>	$\overline{OE}$ Access Time	—	4	—	5	ns
t <sub>HZOE<sup>(2)</sup></sub>	$\overline{OE}$ to High-Z Output	—	4	—	5	ns
t <sub>LZOE<sup>(2)</sup></sub>	$\overline{OE}$ to Low-Z Output	0	—	0	—	ns
t <sub>HZCE<sup>(2)</sup></sub>	$\overline{CE}$ to High-Z Output	0	4	0	6	ns
t <sub>LZCE<sup>(2)</sup></sub>	$\overline{CE}$ to Low-Z Output	3	—	3	—	ns
t <sub>BA</sub>	$\overline{LB}$ , $\overline{UB}$ Access Time	—	4	—	5	ns
t <sub>HZB<sup>(2)</sup></sub>	$\overline{LB}$ , $\overline{UB}$ to High-Z Output	0	3	0	4	ns
t <sub>LZB<sup>(2)</sup></sub>	$\overline{LB}$ , $\overline{UB}$ to Low-Z Output	0	—	0	—	ns
t <sub>PU</sub>	Power Up Time	0	—	0	—	ns
t <sub>PD</sub>	Power Down Time	—	10	—	12	ns

**Notes:**

1. Test conditions assume signal transition times of 3 ns or less, timing reference levels of 1.5V, input pulse levels of 0V to 3.0V and output loading specified in Figure 1.
2. Tested with the load in Figure 2. Transition is measured ±500 mV from steady-state voltage.

**AC TEST LOADS**

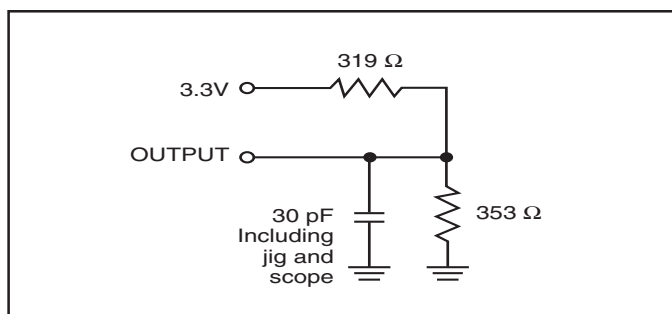

Figure 1

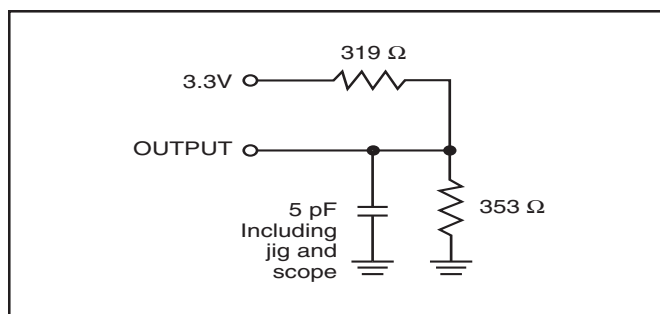

Figure 2

**AC TEST CONDITIONS**

Parameter	Unit
Input Pulse Level	0V to 3.0V
Input Rise and Fall Times	3 ns
Input and Output Timing and Reference Level	1.5V
Output Load	See Figures 1 and 2

AC WAVEFORMS

READ CYCLE NO. 1<sup>(1,2)</sup> (Address Controlled) ( $\overline{CE} = \overline{OE} = V_{IL}$ ,  $\overline{UB}$  or  $\overline{LB} = V_{IL}$ )

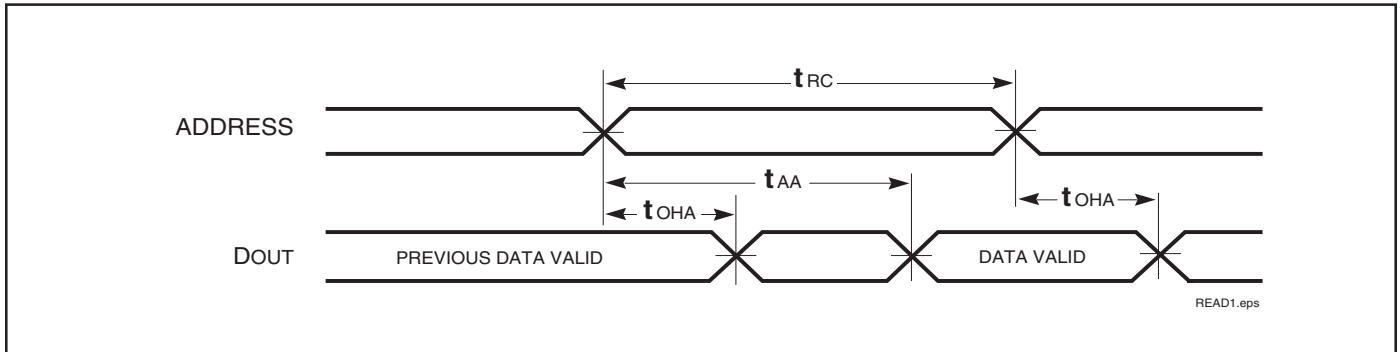

READ CYCLE NO. 2<sup>(1,3)</sup>

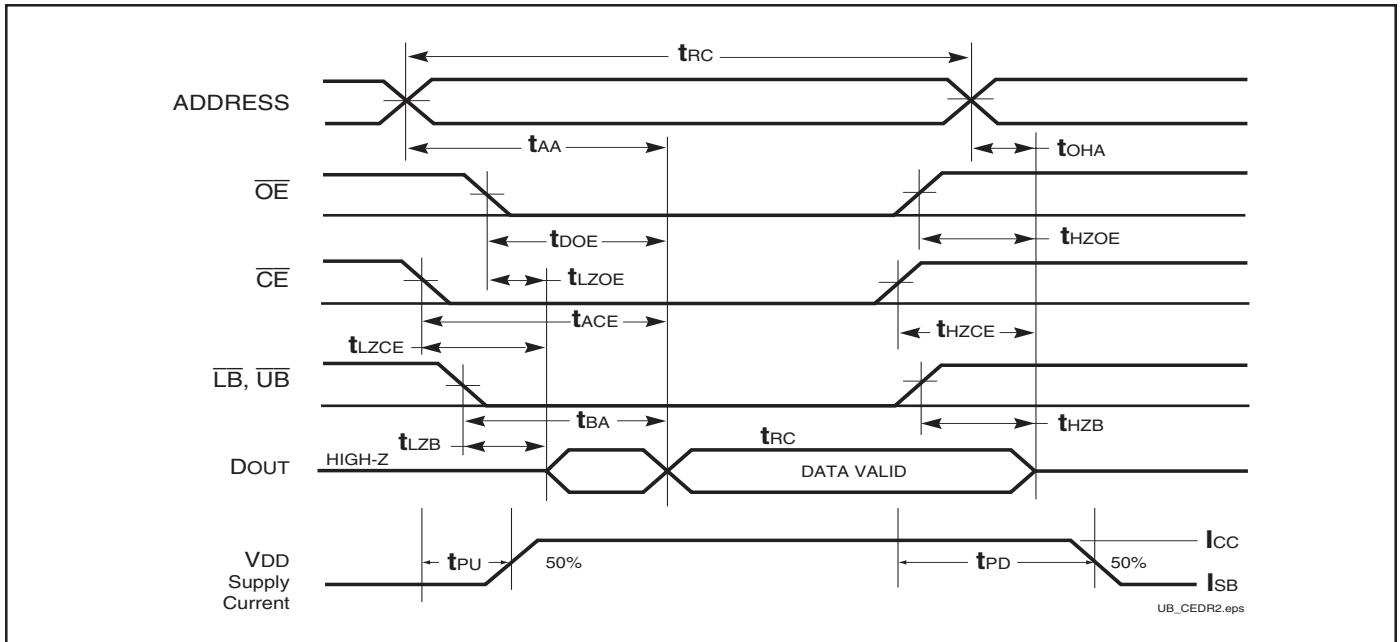

Notes:

1.  $\overline{WE}$  is HIGH for a Read Cycle.
2. The device is continuously selected.  $\overline{OE}$ ,  $\overline{CE}$ ,  $\overline{UB}$ , or  $\overline{LB} = V_{IL}$ .
3. Address is valid prior to or coincident with  $\overline{CE}$  LOW transition.

WRITE CYCLE SWITCHING CHARACTERISTICS<sup>(1,3)</sup> (Over Operating Range)

Symbol	Parameter	-10		-12		Unit
		Min.	Max.	Min.	Max.	
t <sub>WC</sub>	Write Cycle Time	10	—	12	—	ns
t <sub>SCE</sub>	$\overline{CE}$ to Write End	9	—	10	—	ns
t <sub>AW</sub>	Address Setup Time to Write End	8	—	8	—	ns
t <sub>HA</sub>	Address Hold from Write End	0	—	0	—	ns
t <sub>SA</sub>	Address Setup Time	0	—	0	—	ns
t <sub>PBW</sub>	$\overline{LB}$ , $\overline{UB}$ Valid to End of Write	8	—	8	—	ns
t <sub>PWE1</sub>	$\overline{WE}$ Pulse Width	8	—	8	—	ns
t <sub>PWE2</sub>	$\overline{WE}$ Pulse Width ( $\overline{OE}$ = LOW)	10	—	10	—	ns
t <sub>SD</sub>	Data Setup to Write End	6	—	6	—	ns
t <sub>HD</sub>	Data Hold from Write End	0	—	0	—	ns
t <sub>HZWE</sub> <sup>(2)</sup>	$\overline{WE}$ LOW to High-Z Output	—	5	—	6	ns
t <sub>LZWE</sub> <sup>(2)</sup>	$\overline{WE}$ HIGH to Low-Z Output	2	—	2	—	ns

**Notes:**

1. Test conditions assume signal transition times of 3 ns or less, timing reference levels of 1.5V, input pulse levels of 0V to 3.0V and output loading specified in Figure 1.
2. Tested with the load in Figure 2. Transition is measured  $\pm 500$  mV from steady-state voltage. Not 100% tested.
3. The internal write time is defined by the overlap of  $\overline{CE}$  LOW and  $\overline{UB}$  or  $\overline{LB}$  and  $\overline{WE}$  LOW. All signals must be in valid states to initiate a Write, but any one can go inactive to terminate the Write. The Data Input Setup and Hold timing are referenced to the rising or falling edge of the signal that terminates the write.

AC WAVEFORMS

WRITE CYCLE NO. 1 ( $\overline{CE}$  Controlled,  $\overline{OE}$  is HIGH or LOW) <sup>(1)</sup>

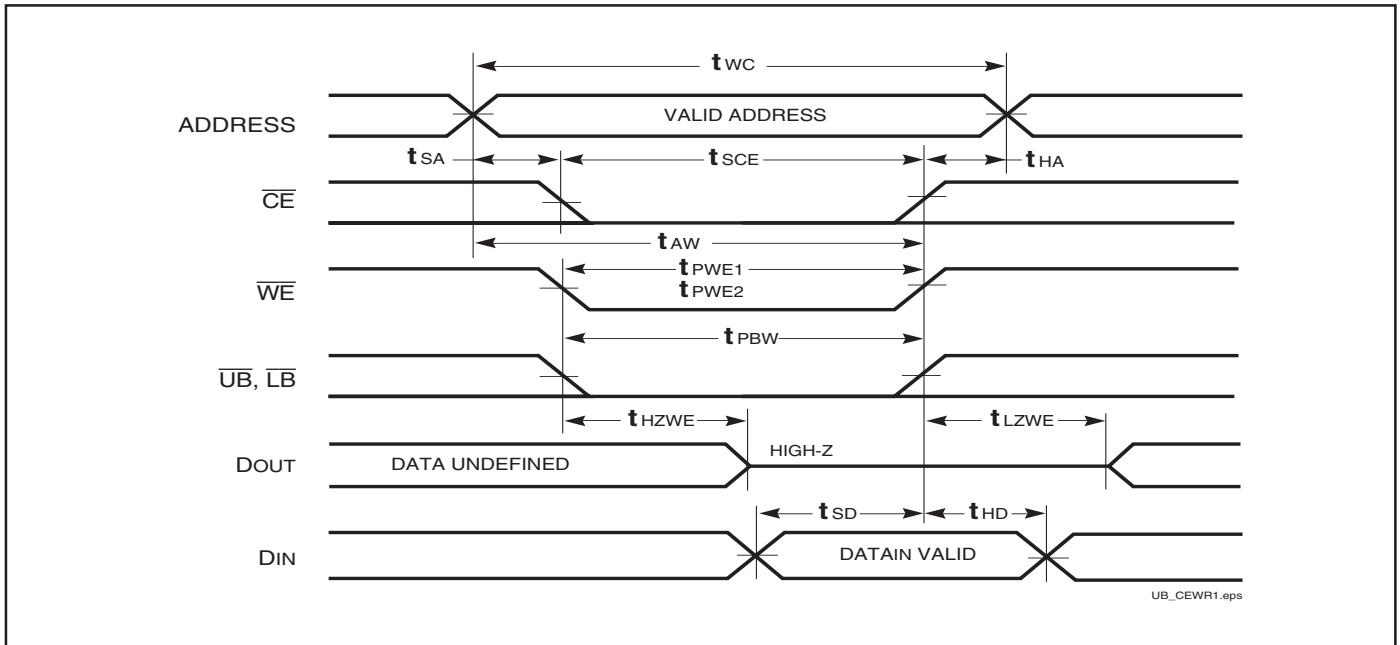

Notes:

1. WRITE is an internally generated signal asserted during an overlap of the LOW states on the  $\overline{CE}$  and  $\overline{WE}$  inputs and at least one of the  $\overline{LB}$  and  $\overline{UB}$  inputs being in the LOW state.
2.  $WRITE = (\overline{CE}) [ (\overline{LB}) = (\overline{UB}) ] (\overline{WE})$ .

WRITE CYCLE NO. 2 ( $\overline{WE}$  Controlled.  $\overline{OE}$  is HIGH During Write Cycle) <sup>(1,2)</sup>

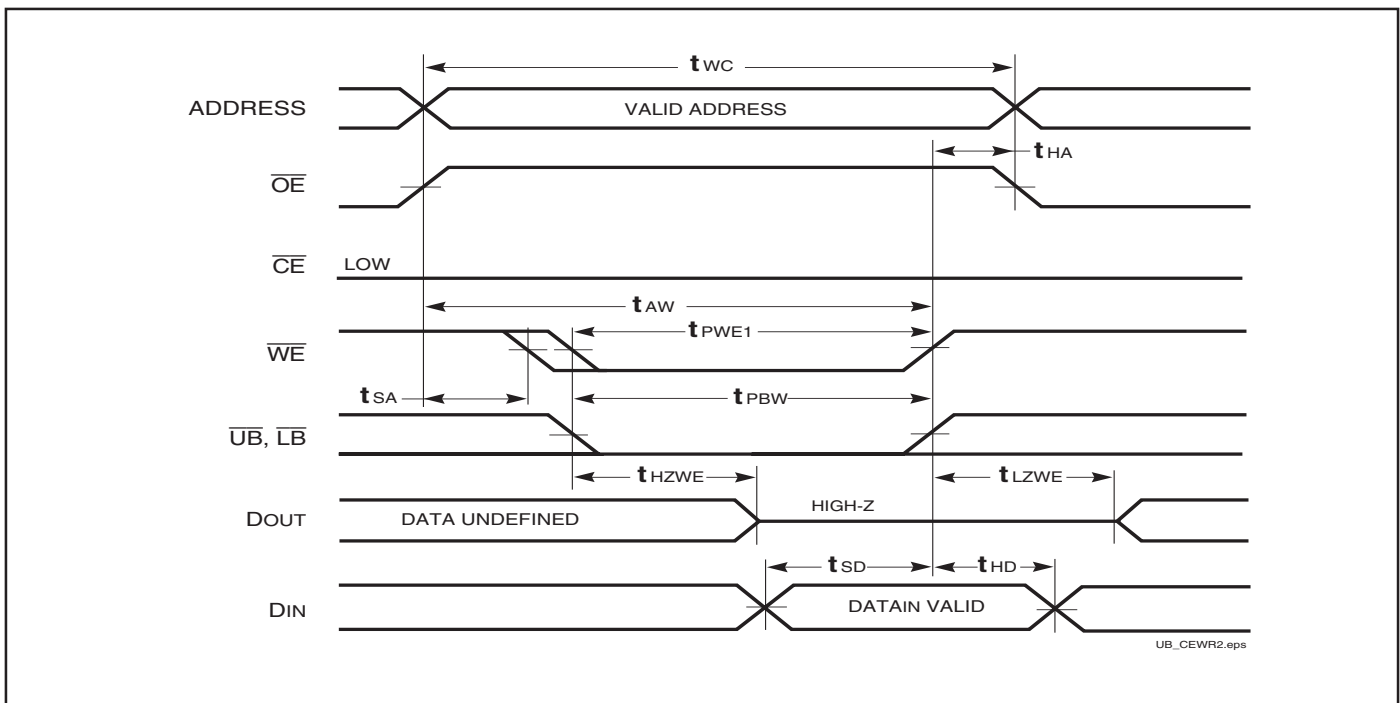

## AC WAVEFORMS

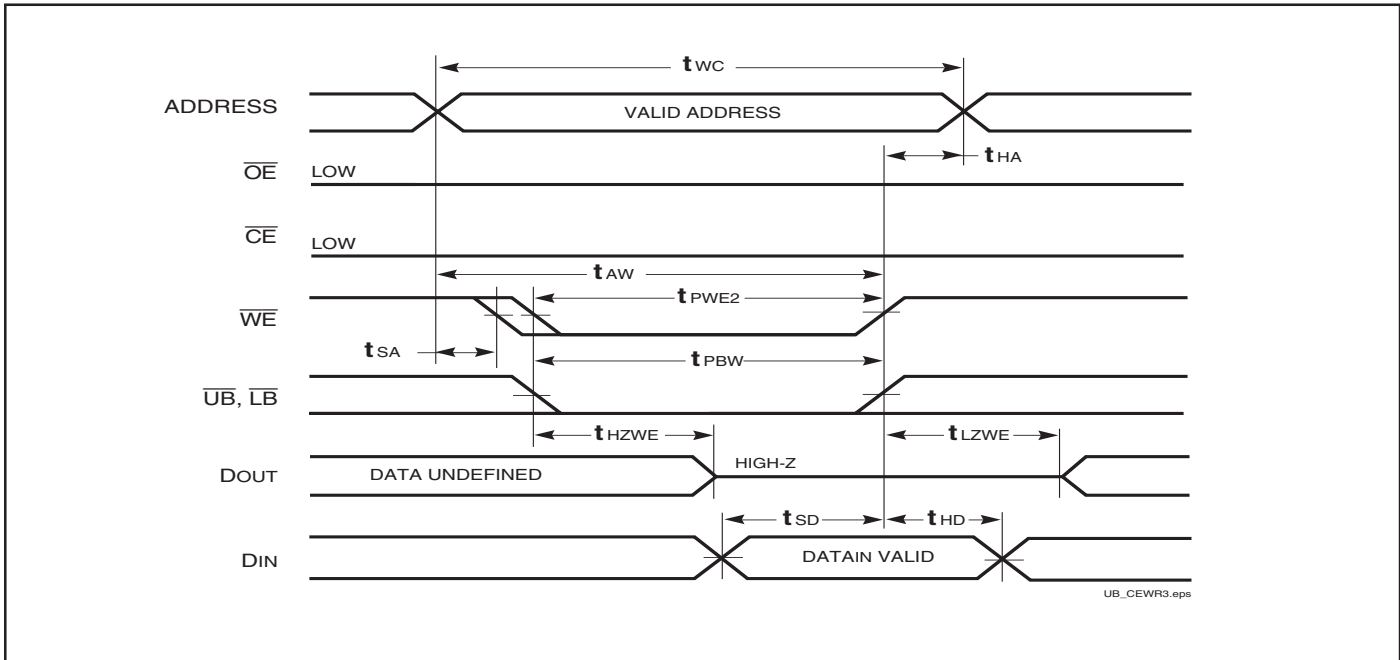
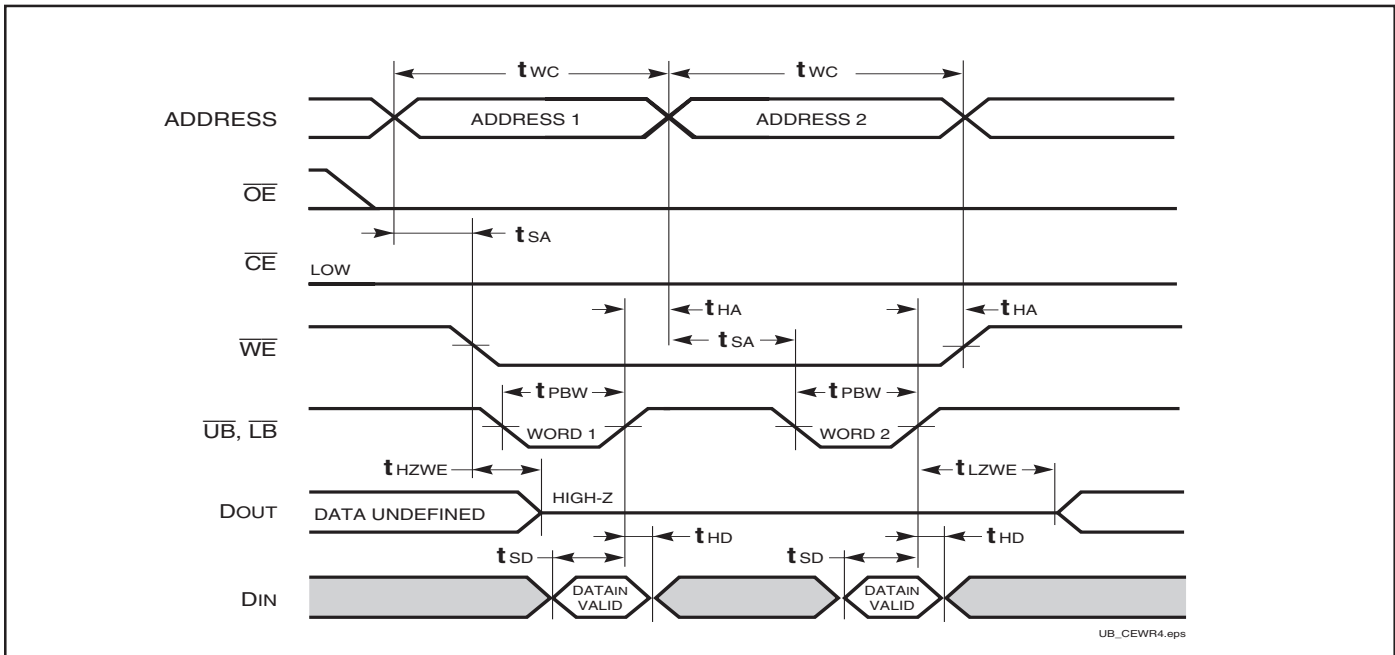
WRITE CYCLE NO. 3 ( $\overline{WE}$  Controlled,  $\overline{OE}$  is LOW During Write Cycle) <sup>(1)</sup>WRITE CYCLE NO. 4 ( $\overline{LB}$ ,  $\overline{UB}$  Controlled, Back-to-Back Write) <sup>(1,3)</sup>

## Notes:

1. The internal Write time is defined by the overlap of  $\overline{CE} = \text{LOW}$ ,  $\overline{UB}$  and/or  $\overline{LB} = \text{LOW}$ , and  $\overline{WE} = \text{LOW}$ . All signals must be in valid states to initiate a Write, but any can be deasserted to terminate the Write. The  $t_{SA}$ ,  $t_{HA}$ ,  $t_{SD}$ , and  $t_{HD}$  timing is referenced to the rising or falling edge of the signal that terminates the Write.
2. Tested with  $\overline{OE}$  HIGH for a minimum of 4 ns before  $\overline{WE} = \text{LOW}$  to place the I/O in a HIGH-Z state.
3.  $\overline{WE}$  may be held LOW across many address cycles and the  $\overline{LB}$ ,  $\overline{UB}$  pins can be used to control the Write function.

## DATA RETENTION SWITCHING CHARACTERISTICS

Symbol	Parameter	Test Condition	Options	Min.	Typ. <sup>(1)</sup>	Max.	Unit
V <sub>DR</sub>	V <sub>DD</sub> for Data Retention	See Data Retention Waveform		2.0	—	3.6	V
I <sub>DR</sub>	Data Retention Current	V <sub>DD</sub> = 2.0V, $\overline{CE} \geq V_{DD} - 0.2V$	A1 A2 A3	—	5	10 15 20	mA
t <sub>SDR</sub>	Data Retention Setup Time	See Data Retention Waveform		0	—	—	ns
t <sub>RDR</sub>	Recovery Time	See Data Retention Waveform		t <sub>RC</sub>	—	—	ns

**Note 1:** Typical values are measured at V<sub>DD</sub> = 3.0V, T<sub>A</sub> = 25°C and not 100% tested.

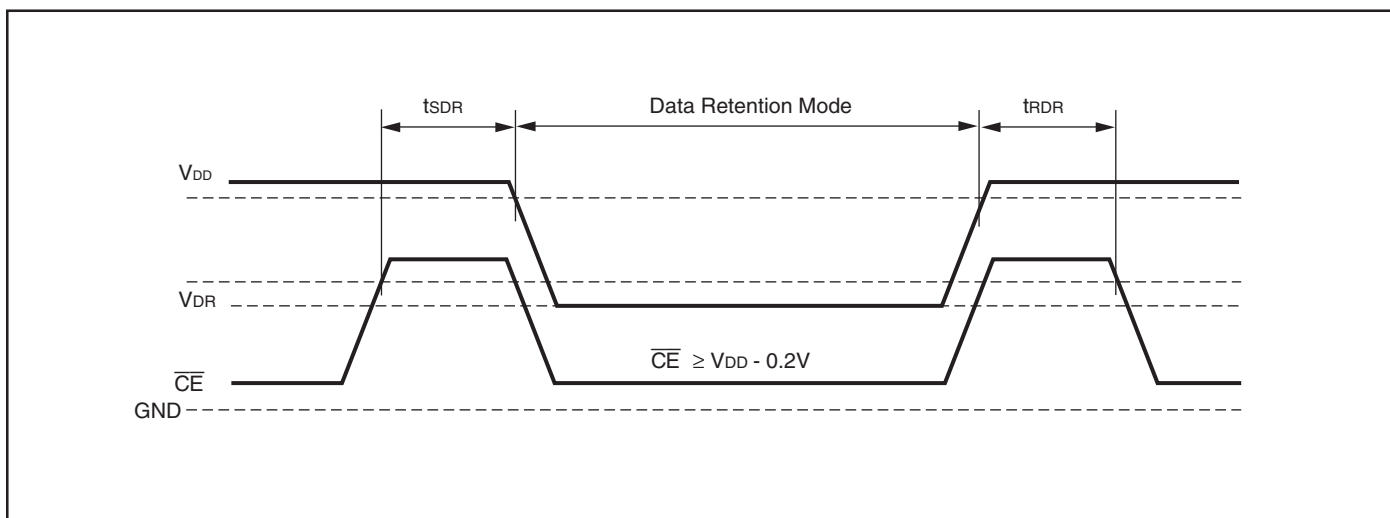
DATA RETENTION WAVEFORM ( $\overline{CE}$  Controlled)

## ORDERING INFORMATION

Temperature Range (A1): -40°C to +85°C

Speed (ns)	Order Part No.	Package
10	IS64LV25616AL-10TA1	TSOP (Type II)

Temperature Range (A2): -40°C to +105°C

Speed (ns)	Order Part No.	Package
12	IS64LV25616AL-12TA2	TSOP (Type II)
	IS64LV25616AL-12TLA2	TSOP (Type II), Lead-free
	IS64LV25616AL-12BA2	Mini BGA (8mm x 10mm)

Temperature Range (A3): -40°C to +125°C

Speed(ns)	Order Part No.	Package
12	IS64LV25616AL-12TA3	TSOP (Type II)
	IS64LV25616AL-12TLA3	TSOP (Type II), Lead-free
	IS64LV25616AL-12BA3	Mini BGA (8mm x 10mm)
	IS64LV25616AL-12BLA3	Mini BGA (8mm x 10mm), Lead-free

# PACKAGING INFORMATION



## Mini Ball Grid Array Package Code: B (48-pin)

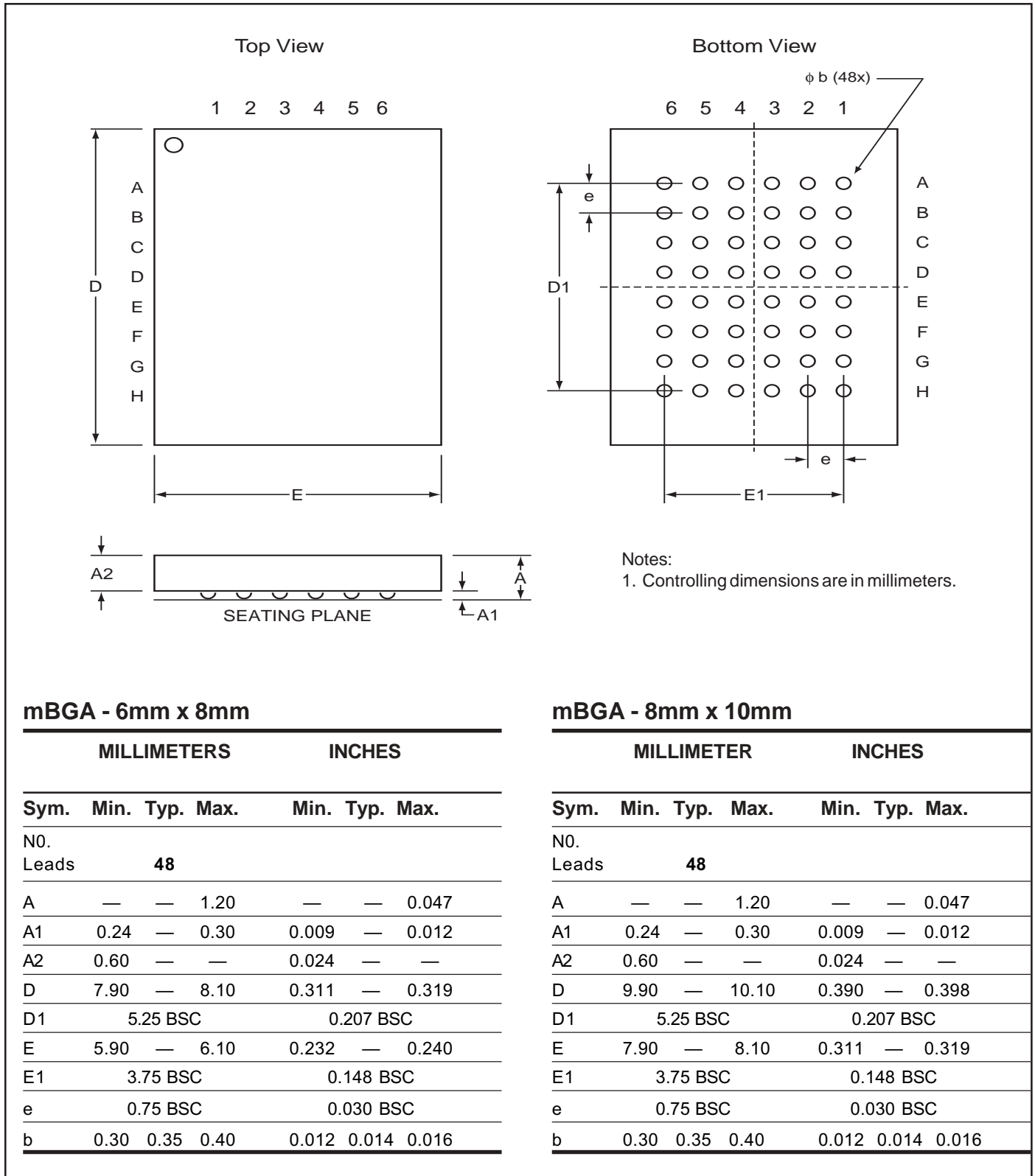

Copyright © 2003 Integrated Silicon Solution, Inc. All rights reserved. ISSI reserves the right to make changes to this specification and its products at any time without notice. ISSI assumes no liability arising out of the application or use of any information, products or services described herein. Customers are advised to obtain the latest version of this device specification before relying on any published information and before placing orders for products.

Integrated Silicon Solution, Inc. — [www.issi.com](http://www.issi.com) — 1-800-379-4774

Rev. D  
01/15/03

# PACKAGING INFORMATION



## Plastic TSOP Package Code: T (Type II)

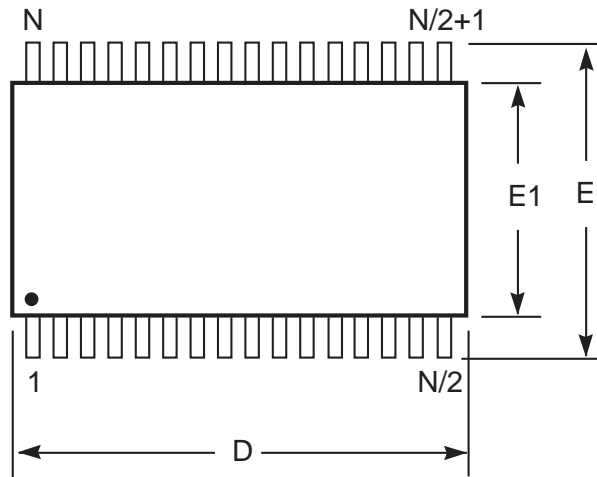

### Notes:

1. Controlling dimension: millimeters, unless otherwise specified.
2. BSC = Basic lead spacing between centers.
3. Dimensions D and E1 do not include mold flash protrusions and should be measured from the bottom of the package.
4. Formed leads shall be planar with respect to one another within 0.004 inches at the seating plane.

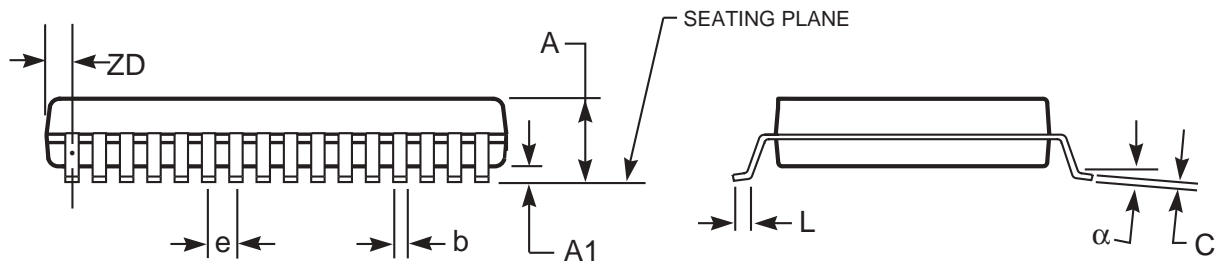

Plastic TSOP (T - Type II)

Symbol	Millimeters		Inches		Millimeters		Inches		Millimeters		Inches	
	Min	Max	Min	Max	Min	Max	Min	Max	Min	Max	Min	Max
Ref. Std.												
No. Leads (N)	32				44				50			
A	—	1.20	—	0.047	—	1.20	—	0.047	—	1.20	—	0.047
A1	0.05	0.15	0.002	0.006	0.05	0.15	0.002	0.006	0.05	0.15	0.002	0.006
b	0.30	0.52	0.012	0.020	0.30	0.45	0.012	0.018	0.30	0.45	0.012	0.018
C	0.12	0.21	0.005	0.008	0.12	0.21	0.005	0.008	0.12	0.21	0.005	0.008
D	20.82	21.08	0.820	0.830	18.31	18.52	0.721	0.729	20.82	21.08	0.820	0.830
E1	10.03	10.29	0.391	0.400	10.03	10.29	0.395	0.405	10.03	10.29	0.395	0.405
E	11.56	11.96	0.451	0.466	11.56	11.96	0.455	0.471	11.56	11.96	0.455	0.471
e	1.27 BSC		0.050 BSC		0.80 BSC		0.032 BSC		0.80 BSC		0.031 BSC	
L	0.40	0.60	0.016	0.024	0.41	0.60	0.016	0.024	0.40	0.60	0.016	0.024
ZD	0.95 REF		0.037 REF		0.81 REF		0.032 REF		0.88 REF		0.035 REF	
alpha	0°	5°	0°	5°	0°	5°	0°	5°	0°	5°	0°	5°

Copyright © 2003 Integrated Silicon Solution, Inc. All rights reserved. ISSI reserves the right to make changes to this specification and its products at any time without notice. ISSI assumes no liability arising out of the application or use of any information, products or services described herein. Customers are advised to obtain the latest version of this device specification before relying on any published information and before placing orders for products.

## Looking for pricing, stock, or lifecycle information?

Click below to explore more details on WIN SOURCE:

- ⊖ [View IS64LV25616AL-12TLA3-TR on WIN SOURCE](#)
- ⊖ [ISSI, Integrated Silicon Solution Inc Information](#)

## Optimize Your Supply Chain with WIN SOURCE Solutions

- ✓ Global Sourcing Solution
- ✓ Obsolete Management
- ✓ Cost Control Management
- ✓ Shortage Management
- ✓ Alternative Solution
- ✓ Excess Inventory Management