



## 64Kx32, 64Kx36 SYNCHRONOUS FLOW-THROUGH STATIC RAM

MAY 2017

### FEATURES

- Internal self-timed write cycle
- Individual Byte Write Control and Global Write
- Clock controlled, registered address, data and control
- Interleaved or linear burst sequence control using MODE input
- Three chip enables for simple depth expansion and address pipelining
- Common data inputs and data outputs
- Power-down control by ZZ input
- JEDEC 100-Pin TQFP package
- Power Supply:
  - +3.3V V<sub>DD</sub>
  - +3.3V or 2.5V V<sub>DDQ</sub>
- Control pins mode upon power-up:
  - MODE in interleave burst mode
  - ZZ in normal operation mode
- Industrial Temperature Available:  
(-40°C to +85°C)
- Lead-free available

### DESCRIPTION

The *ISSI* IS61LF6432A and IS61LF6436A are high-speed, low-power synchronous static RAM designed to provide a burstable, high-performance, memory. IS61LF6432A is organized as 65,536 words by 32 bits. IS61LF6436A is organized as 65,536 words by 36 bits. They are fabricated with *ISSI*'s advanced CMOS technology. The device integrates a 2-bit burst counter, high-speed SRAM core, and high-drive capability outputs into a single monolithic circuit. All synchronous inputs pass through registers controlled by a positive-edge-triggered single clock input.

Write cycles are internally self-timed and are initiated by the rising edge of the clock input. Write cycles can be from one to four bytes wide as controlled by the write control inputs.

Separate byte enables allow individual bytes to be written.  $\overline{BWA}$  controls DQa,  $\overline{BWb}$  controls DQb,  $\overline{BWc}$  controls DQc,  $\overline{BWD}$  controls DQd, conditioned by  $\overline{BWE}$  being LOW. A LOW on  $\overline{GW}$  input would cause all bytes to be written.

Bursts can be initiated with either  $\overline{ADSP}$  (Address Status Processor) or  $\overline{ADSC}$  (Address Status Cache Controller) input pins. Subsequent burst addresses can be generated internally by the IS61LF6432A/36A and controlled by the  $\overline{ADV}$  (burst address advance) input pin.

The mode pin is used to select the burst sequence order. Linear burst is achieved when this pin is tied LOW. Interleave burst is achieved when this pin is tied HIGH or left floating.

### FAST ACCESS TIME

Symbol	Parameter	8.5	Unit
t <sub>KQ</sub>	Clock Access Time	8.5	ns
t <sub>KC</sub>	Cycle Time	11	ns
	Frequency	90	MHz

Copyright © 2017 Integrated Silicon Solution, Inc. All rights reserved. ISSI reserves the right to make changes to this specification and its products at any time without notice. ISSI assumes no liability arising out of the application or use of any information, products or services described herein. Customers are advised to obtain the latest version of this device specification before relying on any published information and before placing orders for products.

Integrated Silicon Solution, Inc. does not recommend the use of any of its products in life support applications where the failure or malfunction of the product can reasonably be expected to cause failure of the life support system or to significantly affect its safety or effectiveness. Products are not authorized for use in such applications unless Integrated Silicon Solution, Inc. receives written assurance to its satisfaction, that:

- a.) the risk of injury or damage has been minimized;
- b.) the user assume all such risks; and
- c.) potential liability of Integrated Silicon Solution, Inc is adequately protected under the circumstances

**BLOCK DIAGRAM**

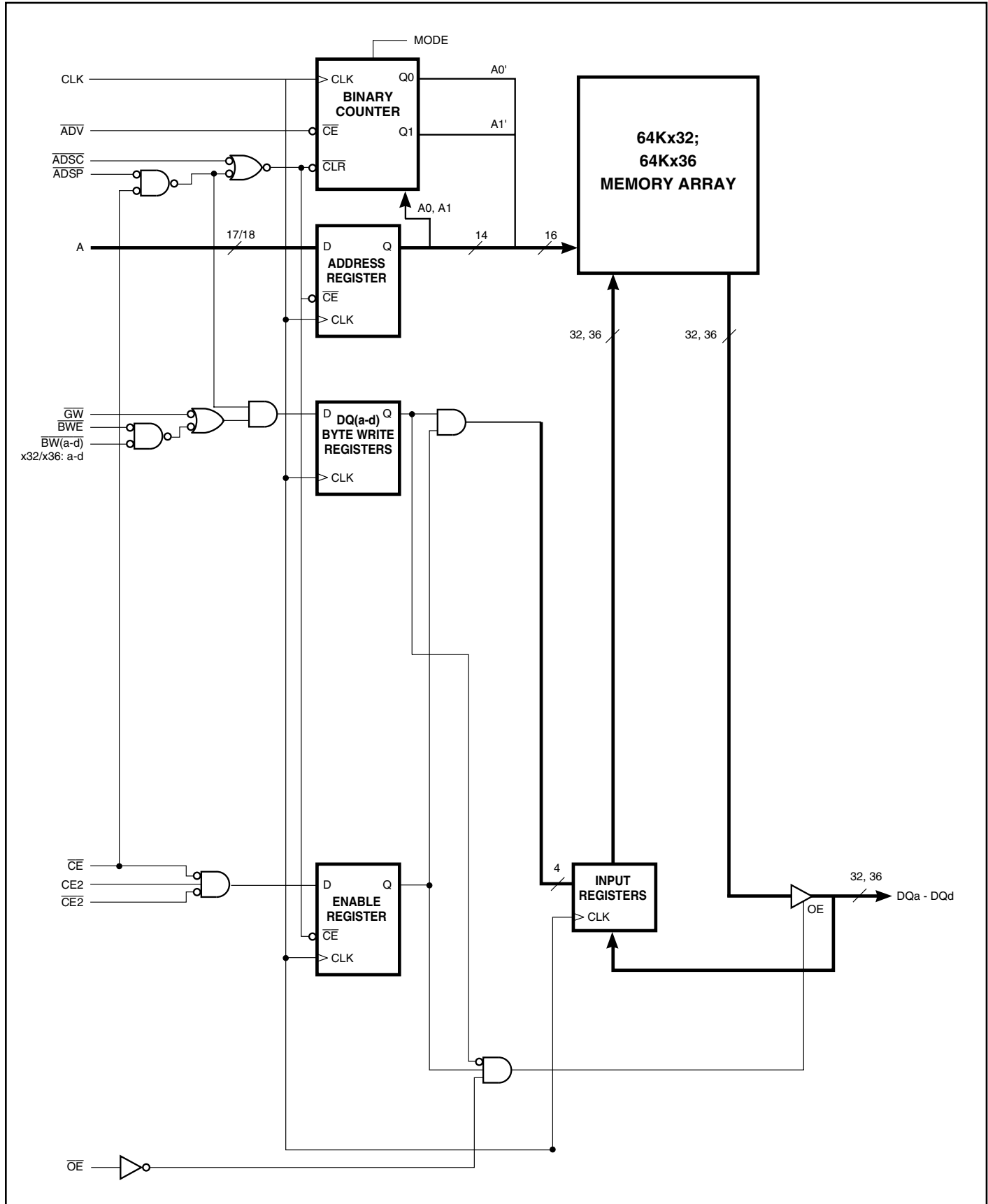

**PIN CONFIGURATION**

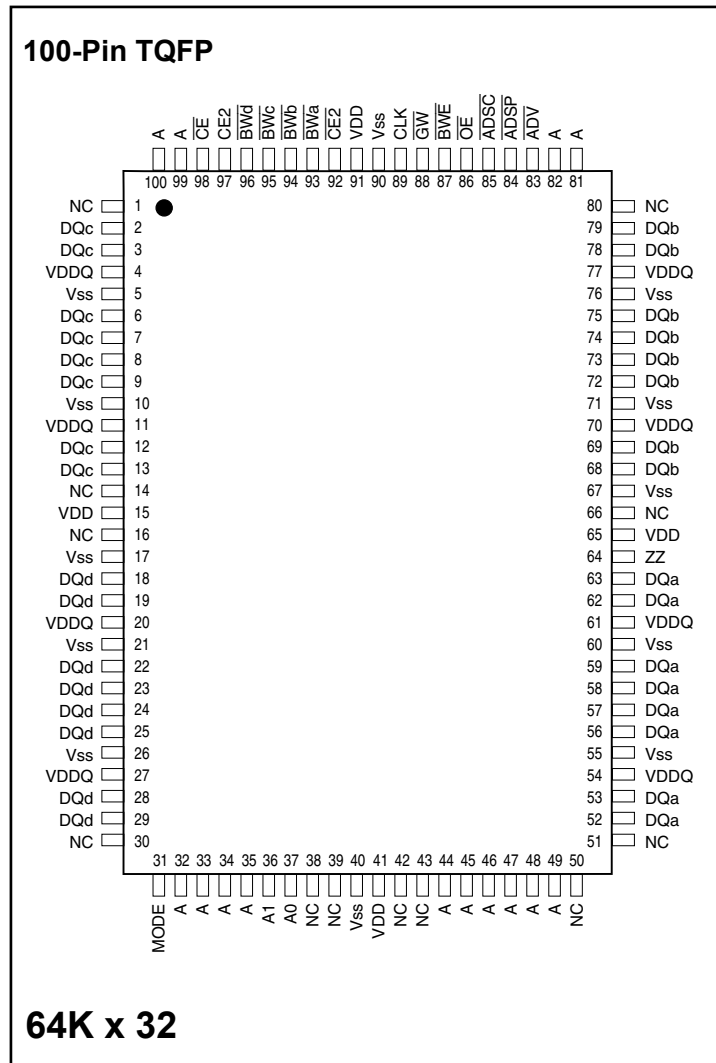

**PIN DESCRIPTIONS**

A0, A1	Synchronous Address Inputs. These pins must be tied to the two LSBs of the address bus.	$\overline{GW}$	Synchronous Global Write Enable
A	Synchronous Address Inputs	$\overline{CE}$ , $\overline{CE2}$ , $CE2$	Synchronous Chip Enable
CLK	Synchronous Clock	$\overline{OE}$	Output Enable
$\overline{ADSP}$	Synchronous Processor Address Status	DQa-DQd	Synchronous Data Input/Output
$\overline{ADSC}$	Synchronous Controller Address Status	MODE	Burst Sequence Mode Selection
$\overline{ADV}$	Synchronous Burst Address Advance	VDD	+3.3V Power Supply
$\overline{BWA}$ - $\overline{BWD}$	Individual Byte Write Enable	Vss	Ground
BWE	Synchronous Byte Write Enable	VDDQ	Isolated Output Buffer Supply: +3.3V or 2.5V
		ZZ	Snooze Enable



**TRUTH TABLE**

Operation	Address Used	Address								
		$\overline{CE}$	CE2	$\overline{CE2}$	$\overline{ADSP}$	$\overline{ADSC}$	$\overline{ADV}$	$\overline{WRITE}$	$\overline{OE}$	DQ
Deselected, Power-down	None	H	X	X	X	L	X	X	X	High-Z
Deselected, Power-down	None	L	X	H	L	X	X	X	X	High-Z
Deselected, Power-down	None	L	L	X	L	X	X	X	X	High-Z
Deselected, Power-down	None	X	X	H	H	L	X	X	X	High-Z
Deselected, Power-down	None	X	L	X	H	L	X	X	X	High-Z
Read Cycle, Begin Burst	External	L	H	L	L	X	X	X	X	Q
Read Cycle, Begin Burst	External	L	H	L	H	L	X	Read	X	Q
Write Cycle, Begin Burst	External	L	H	L	H	L	X	Write	X	D
Read Cycle, Continue Burst	Next	X	X	X	H	H	L	Read	L	Q
Read Cycle, Continue Burst	Next	X	X	X	H	H	L	Read	H	High-Z
Read Cycle, Continue Burst	Next	H	X	X	X	H	L	Read	L	Q
Read Cycle, Continue Burst	Next	H	X	X	X	H	L	Read	H	High-Z
Write Cycle, Continue Burst	Next	X	X	X	H	H	L	Write	X	D
Write Cycle, Continue Burst	Next	H	X	X	X	H	L	Write	X	D
Read Cycle, Suspend Burst	Current	X	X	X	H	H	H	Read	L	Q
Read Cycle, Suspend Burst	Current	X	X	X	H	H	H	Read	H	High-Z
Read Cycle, Suspend Burst	Current	H	X	X	X	H	H	Read	L	Q
Read Cycle, Suspend Burst	Current	H	X	X	X	H	H	Read	H	High-Z
Write Cycle, Suspend Burst	Current	X	X	X	H	H	H	Write	X	D
Write Cycle, Suspend Burst	Current	H	X	X	X	H	H	Write	X	D

**PARTIAL TRUTH TABLE**

Function	$\overline{GW}$	$\overline{BWE}$	$\overline{BWA}$	$\overline{BWb}$	$\overline{BWC}$	$\overline{BWd}$
Read	H	H	X	X	X	X
Read	H	L	H	H	H	H
Write Byte 1	H	L	L	H	H	H
Write All Bytes	H	L	L	L	L	L
Write All Bytes	L	X	X	X	X	X

**INTERLEAVED BURST ADDRESS TABLE (MODE = V<sub>DD</sub> or No Connect)**

External Address A1 A0	1st Burst Address A1 A0	2nd Burst Address A1 A0	3rd Burst Address A1 A0
00	01	10	11
01	00	11	10
10	11	00	01
11	10	01	00

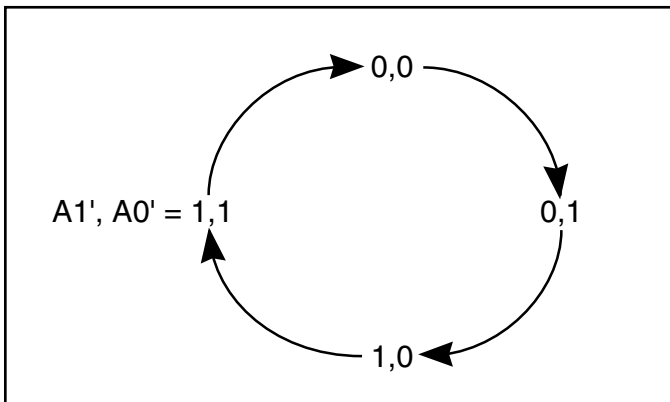

**ABSOLUTE MAXIMUM RATINGS<sup>(1)</sup>**

Symbol	Parameter	Value	Unit
T <sub>STG</sub>	Storage Temperature	-55 to +150	°C
P <sub>D</sub>	Power Dissipation	1.6	W
I <sub>OUT</sub>	Output Current (per I/O)	100	mA
V <sub>IN</sub> , V <sub>OUT</sub>	Voltage Relative to V <sub>SS</sub> for I/O Pins	-0.5 to V <sub>DDQ</sub> + 0.3	V
V <sub>IN</sub>	Voltage Relative to V <sub>SS</sub> for for Address and Control Inputs	-0.5 to V <sub>DD</sub> + 0.5	V
V <sub>DD</sub>	Voltage on V <sub>DD</sub> Supply Relative to V <sub>SS</sub>	-0.5 to 4.6	V

**Notes:**

1. Stress greater than those listed under ABSOLUTE MAXIMUM RATINGS may cause permanent damage to the device. This is a stress rating only and functional operation of the device at these or any other conditions above those indicated in the operational sections of this specification is not implied. Exposure to absolute maximum rating conditions for extended periods may affect reliability.
2. This device contains circuitry to protect the inputs against damage due to high static voltages or electric fields; however, precautions may be taken to avoid application of any voltage higher than maximum rated voltages to this high-impedance circuit.
3. This device contains circuitry that will ensure the output devices are in High-Z at power up.

## OPERATING RANGE

Range	Ambient Temperature	V <sub>DD</sub>	3.3V (I/O) V <sub>DDQ</sub>	2.5V (I/O) V <sub>DDQ</sub>
Industrial	-40°C to +85°C	3.3V, +10%, -5%	3.3V, +10%, -5%	2.5V ± 5%

## DC ELECTRICAL CHARACTERISTICS<sup>(1)</sup> (Over Operating Range)

Symbol	Parameter	Test Conditions	2.5V (I/O)		3.3V (I/O)		Unit
			Min.	Max.	Min.	Max.	
V <sub>OH</sub>	Output HIGH Voltage	I <sub>OH</sub> = -4.0 mA (3.3V) I <sub>OH</sub> = 1.0 mA (2.5V)	2.0	—	2.4	—	V
V <sub>OL</sub>	Output LOW Voltage	I <sub>OL</sub> = 8.0 mA (3.3V) I <sub>OL</sub> = 1.0 mA (2.5V)	—	0.4	—	0.4	V
V <sub>IH</sub>	Input HIGH Voltage		1.7	V <sub>DD</sub> + 0.3	2.0	V <sub>DD</sub> + 0.3	V
V <sub>IL</sub>	Input LOW Voltage			-0.3	0.7	-0.3	0.8 V
I <sub>LI</sub>	Input Leakage Current	V <sub>SS</sub> ≤ V <sub>IN</sub> ≤ V <sub>DD</sub>	-5	5	-5	5	μA
I <sub>LO</sub>	Output Leakage Current	V <sub>SS</sub> ≤ V <sub>OUT</sub> ≤ V <sub>DDQ</sub> , OE = V <sub>I</sub>	-5	5	-5	5	μA

## POWER SUPPLY CHARACTERISTICS (Over Operating Range)

Symbol	Parameter	Test Conditions		8.5 Max.	Unit
I <sub>CC</sub>	AC Operating Supply Current	Device Selected, OE = V <sub>IH</sub> , ZZ ≤ V <sub>IL</sub> , All Inputs ≤ 0.2V or ≥ V <sub>DD</sub> - 0.2V, Cycle Time ≥ t <sub>KC</sub> min.	IND.	150	mA
I <sub>SB1</sub>	Standby Current CMOS Input	Device Deselected, V <sub>DD</sub> = Max., V <sub>IN</sub> ≤ V <sub>SS</sub> + 0.2V or ≥ V <sub>DD</sub> - 0.2V f = 0	IND.	75	mA
I <sub>ZZ</sub>	Sleep Mode	ZZ > V <sub>IH</sub>	IND.	35	mA

### Notes:

- The MODE pin has an internal pullup. This pin may be a No Connect, tied to V<sub>SS</sub>, or tied to V<sub>DD</sub>.
- The MODE pin should be tied to V<sub>DD</sub> or V<sub>SS</sub>. It exhibits ±10 μA maximum leakage current when tied to ≤ V<sub>SS</sub> + 0.2V or ≥ V<sub>DD</sub> - 0.2V.

**CAPACITANCE**<sup>(1,2)</sup>

Symbol	Parameter	Conditions	Max.	Unit
C <sub>IN</sub>	Input Capacitance	V <sub>IN</sub> = 0V	6	pF
C <sub>OUT</sub>	Input/Output Capacitance	V <sub>OUT</sub> = 0V	8	pF

**Notes:**

1. Tested initially and after any design or process changes that may affect these parameters.
2. Test conditions: T<sub>A</sub> = 25°C, f = 1 MHz, V<sub>DD</sub> = 3.3V.

**3.3V I/O AC TEST CONDITIONS**

Parameter	Unit
Input Pulse Level	0V to 3.0V
Input Rise and Fall Times	1.5 ns
Input and Output Timing and Reference Level	1.5V
Output Load	See Figures 1 and 2

**3.3V I/O OUTPUT LOAD EQUIVALENT**

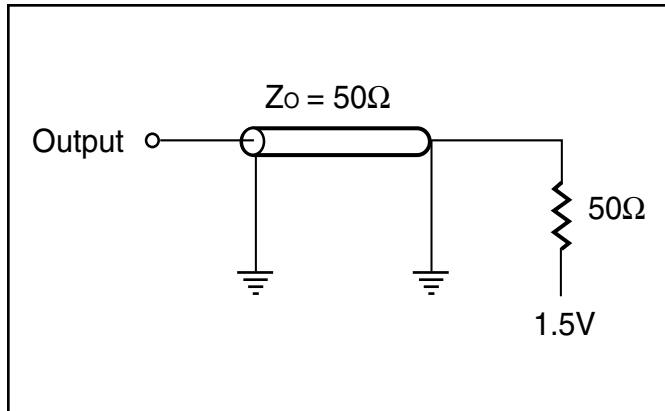

**Figure 1**

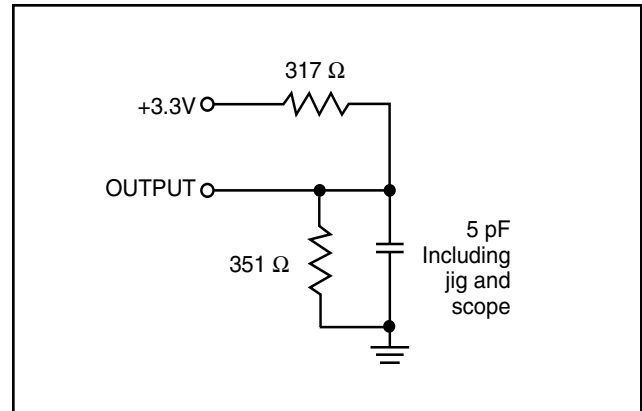
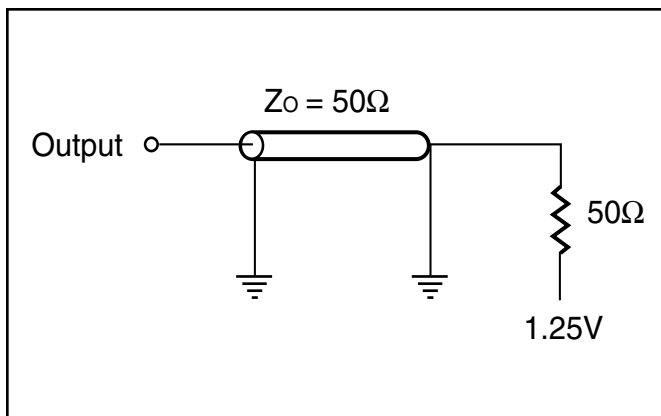

**Figure 2**

**2.5V I/O AC TEST CONDITIONS**

Parameter	Unit
Input Pulse Level	0V to 2.5V
Input Rise and Fall Times	1ns
Input and Output Timing and Reference Level	1.25V
Output Load	See Figures 3 and 4

**2.5V I/O OUTPUT LOAD EQUIVALENT**



**Figure 3**

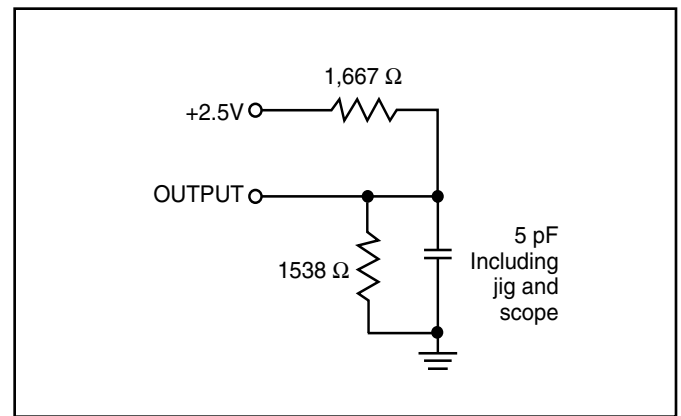

**Figure 4**

**READ/WRITE CYCLE SWITCHING CHARACTERISTICS (Over Operating Range)**

Symbol	Parameter	8.5		Unit
		Min.	Max.	
f <sub>MAX</sub> <sup>(3)</sup>	Clock Frequency	—	90	MHz
t <sub>KC</sub> <sup>(3)</sup>	Cycle Time	11	—	ns
t <sub>KH</sub>	Clock High Time	4.5	—	ns
t <sub>KL</sub> <sup>(3)</sup>	Clock Low Time	4.5	—	ns
t <sub>KQ</sub> <sup>(3)</sup>	Clock Access Time	—	8.5	ns
t <sub>KQX</sub> <sup>(1)</sup>	Clock High to Output Invalid	2	—	ns
t <sub>KQLZ</sub> <sup>(1,2)</sup>	Clock High to Output Low-Z	0	—	ns
t <sub>KQHZ</sub> <sup>(1,2)</sup>	Clock High to Output High-Z	2	3.5	ns
t <sub>OEQ</sub> <sup>(3)</sup>	Output Enable to Output Valid	—	4.0	ns
t <sub>OEQX</sub> <sup>(1)</sup>	Output Enable to Output Invalid		2	ns
t <sub>OELZ</sub> <sup>(1,2)</sup>	Output Enable to Output Low-Z		0	ns
t <sub>OEHZ</sub> <sup>(1,2)</sup>	Output Disable to Output High-Z	—	5.0	ns
t <sub>AS</sub> <sup>(3)</sup>	Address Setup Time	2	—	ns
t <sub>SS</sub> <sup>(3)</sup>	Address Status Setup Time	2	—	ns
t <sub>WS</sub> <sup>(3)</sup>	Write Setup Time	2	—	ns
t <sub>CES</sub> <sup>(3)</sup>	Chip Enable Setup Time	2	—	ns
t <sub>AVS</sub> <sup>(3)</sup>	Address Advance Setup Time	2	—	ns
t <sub>AH</sub> <sup>(3)</sup>	Address Hold Time	1	—	ns
t <sub>SH</sub> <sup>(3)</sup>	Address Status Hold Time	0.5	—	ns
t <sub>WH</sub> <sup>(3)</sup>	Write Hold Time	0.5	—	ns
t <sub>CEH</sub> <sup>(3)</sup>	Chip Enable Hold Time	0.5	—	ns
t <sub>AVH</sub> <sup>(3)</sup>	Address Advance Hold Time	0.5	—	ns

**Notes:**

1. Guaranteed but not 100% tested. This parameter is periodically sampled.
2. Tested with load in Figure 2.
3. Tested with load in Figure 1.

**READ/WRITE CYCLE TIMING**

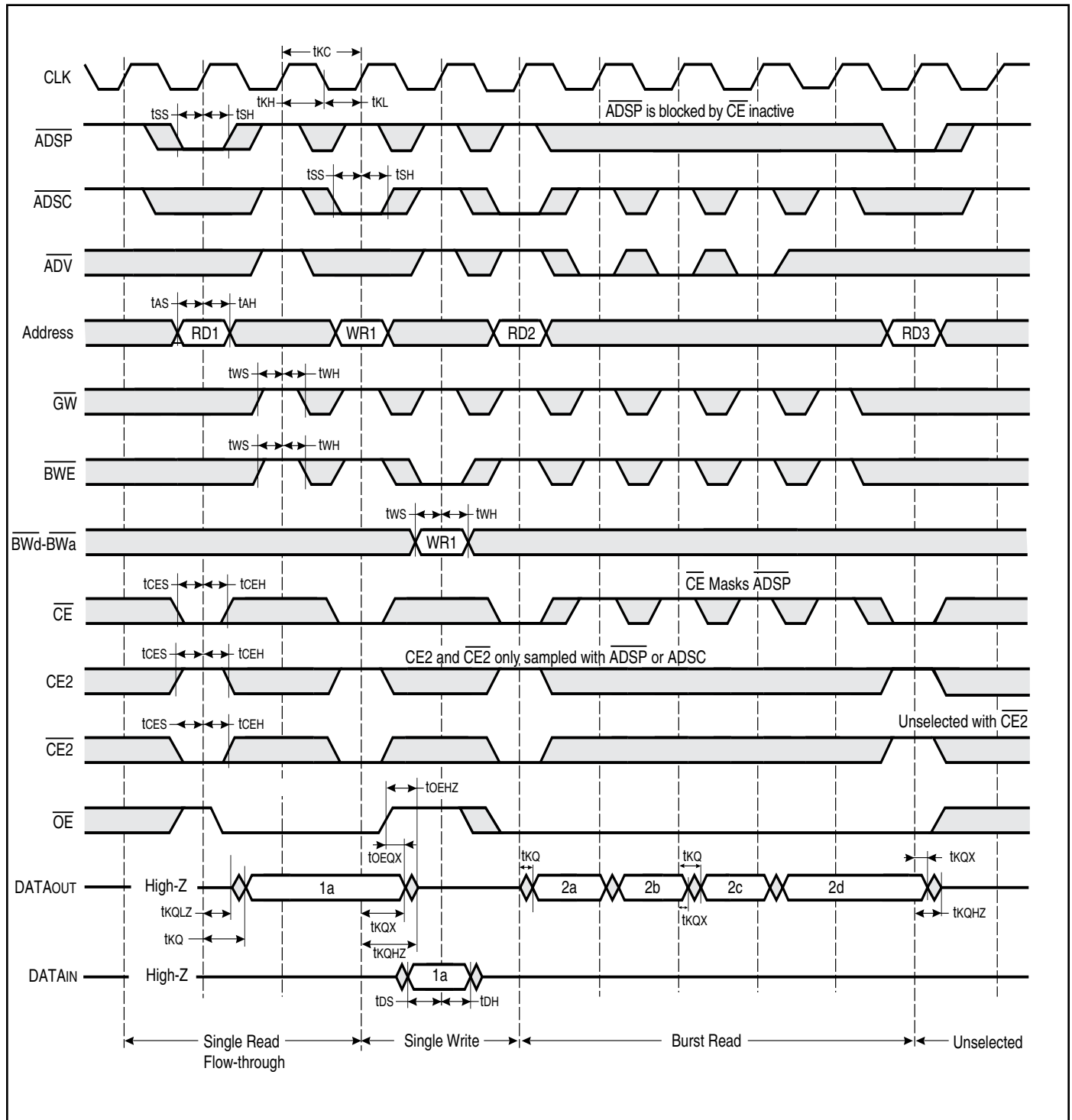

**WRITE CYCLE SWITCHING CHARACTERISTICS (Over Operating Range)**

Symbol	Parameter	8.5		Unit
		Min.	Max.	
t <sub>CC</sub> <sup>(1)</sup>	Cycle Time	11	—	ns
t <sub>KH</sub> <sup>(1)</sup>	Clock High Time	4.5	—	ns
t <sub>KL</sub> <sup>(1)</sup>	Clock Low Time	4.5	—	ns
t <sub>AS</sub> <sup>(1)</sup>	Address Setup Time	2	—	ns
t <sub>SS</sub> <sup>(1)</sup>	Address Status Setup Time	2	—	ns
t <sub>WS</sub> <sup>(1)</sup>	Write Setup Time	2	—	ns
t <sub>DS</sub> <sup>(1)</sup>	Data In Setup Time	3	—	ns
t <sub>CES</sub> <sup>(1)</sup>	Chip Enable Setup Time	2	—	ns
t <sub>AVS</sub> <sup>(1)</sup>	Address Advance Setup Time	2	—	ns
t <sub>AH</sub> <sup>(1)</sup>	Address Hold Time	1	—	ns
t <sub>SH</sub> <sup>(1)</sup>	Address Status Hold Time	0.5	—	ns
t <sub>DH</sub> <sup>(1)</sup>	Data In Hold Time	1	—	ns
t <sub>WH</sub> <sup>(1)</sup>	Write Hold Time	0.5	—	ns
t <sub>CEH</sub> <sup>(1)</sup>	Chip Enable Hold Time	0.5	—	ns
t <sub>AVH</sub> <sup>(1)</sup>	Address Advance Hold Time	0.5	—	ns

**Notes:**

1. Tested with load in Figure 1.

**WRITE CYCLE TIMING**

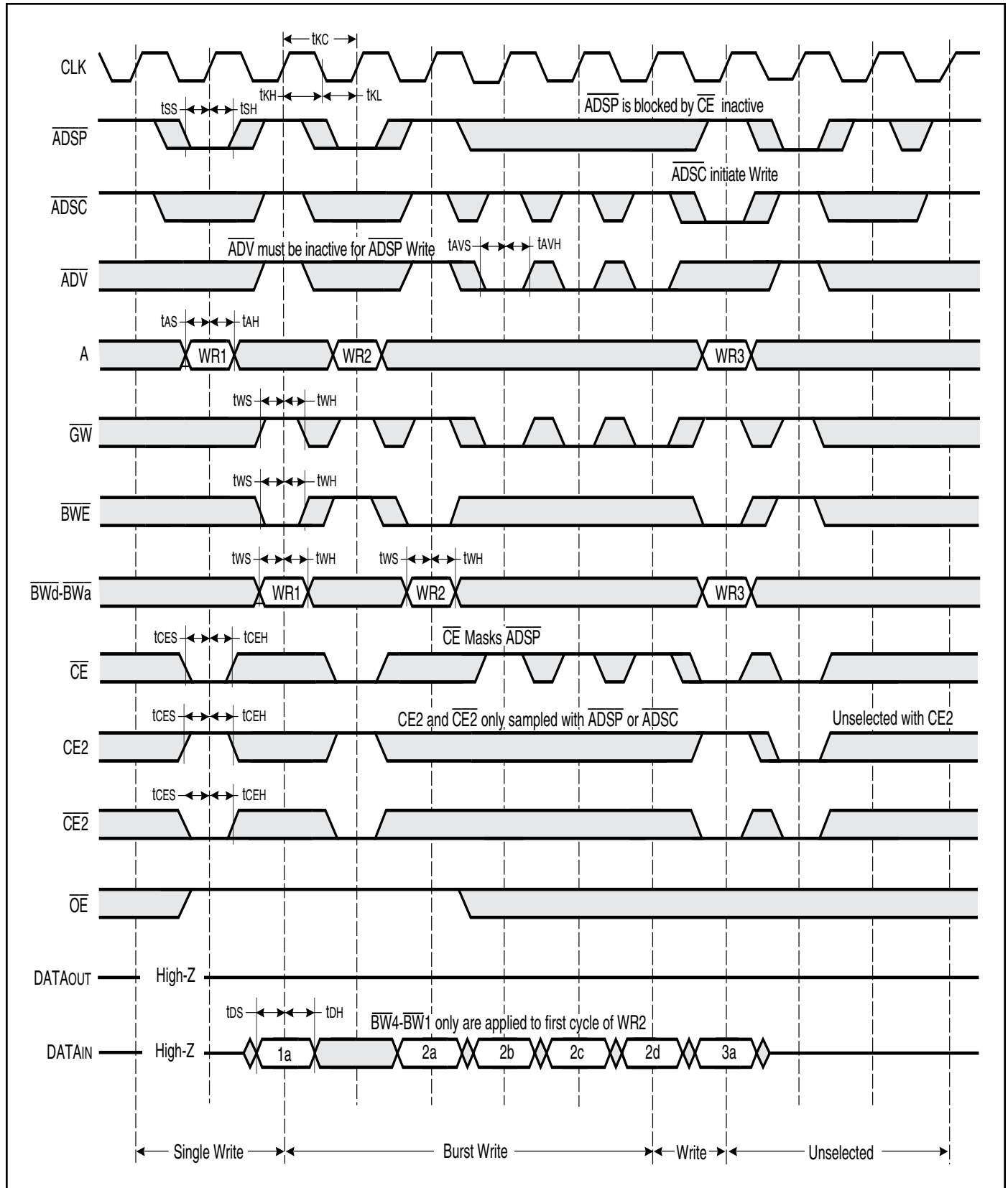

**SNOOZE MODE ELECTRICAL CHARACTERISTICS**

Symbol	Parameter	Conditions	Min.	Max.	Unit
I <sub>SB2</sub>	Current during SNOOZE MODE	ZZ ≥ V <sub>ih</sub>	—	35	mA
t <sub>PDS</sub>	ZZ active to input ignored		—	2	cycle
t <sub>PUS</sub>	ZZ inactive to input sampled		2	—	cycle
t <sub>ZZI</sub>	ZZ active to SNOOZE current		—	2	cycle
t <sub>RZZI</sub>	ZZ inactive to exit SNOOZE current		0	—	ns

**SNOOZE MODE TIMING**

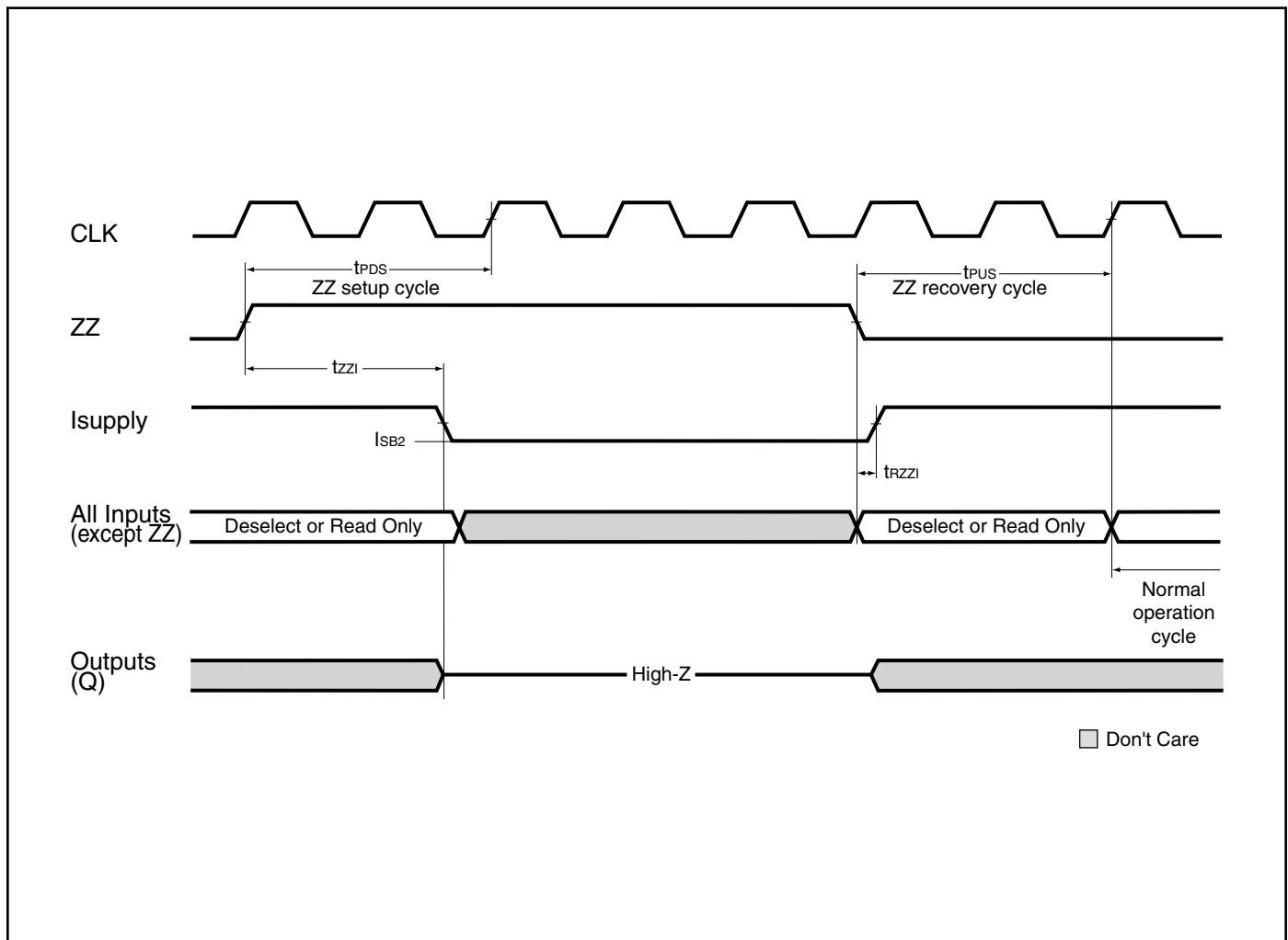

**ORDERING INFORMATION**

**3.3V I/O OR 2.5V I/O**

**Industrial Range: -40°C TO +85°C**

<b>Speed (ns)</b>	<b>Order Part No.</b>	<b>Package</b>
8.5	IS61LF6432A-8.5TQLI	TQFP, Lead-free
8.5	IS61LF6436A-8.5TQLI	TQFP, Lead-free

PACKAGE OUTLINE DRAWING

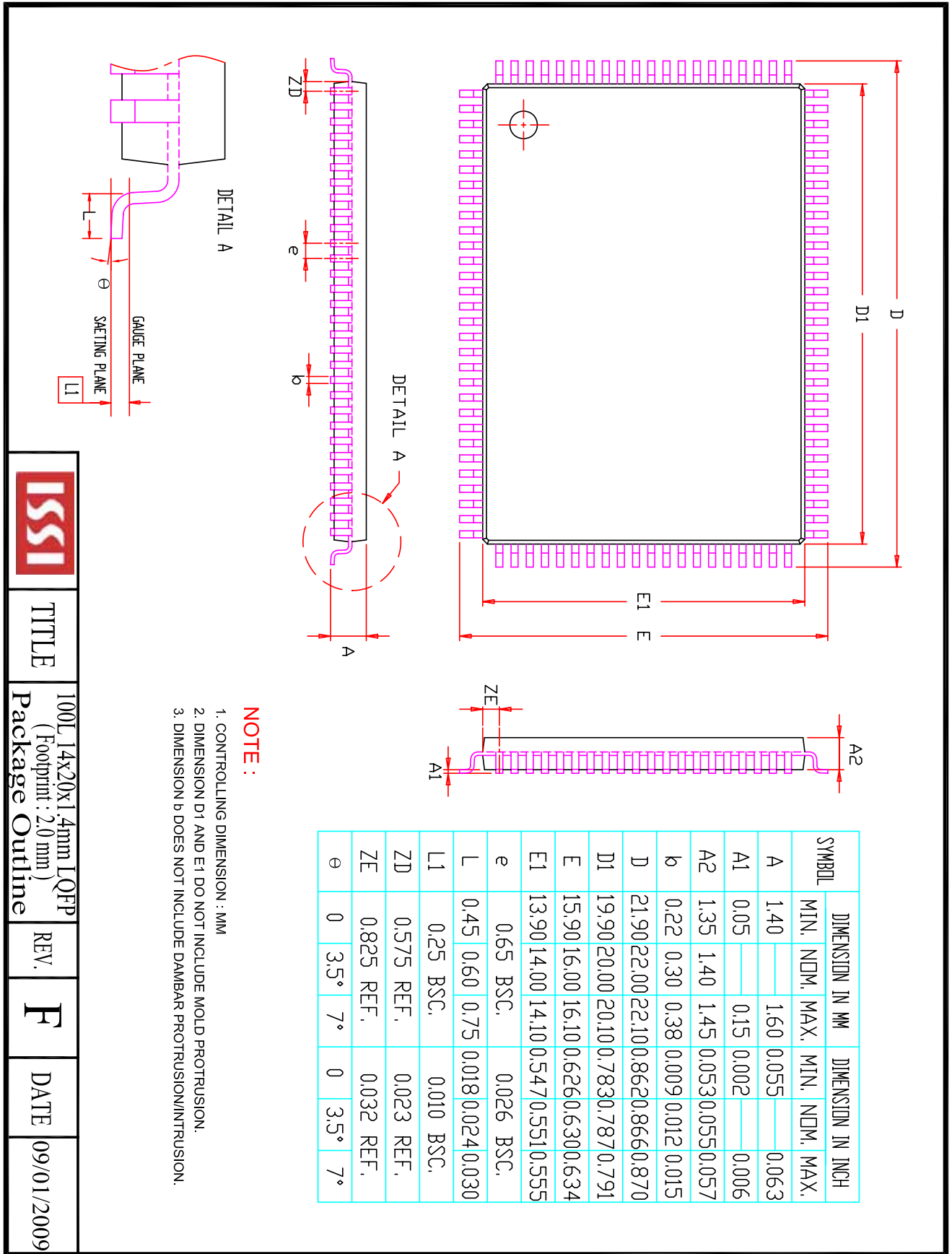

	TITLE	100L14x20x1 4mm LQFP (Footprint : 2.0 mm)	REV.	F	DATE	09/01/2009
	Package Outline					

## Looking for pricing, stock, or lifecycle information?

Click below to explore more details on WIN SOURCE:

- ⊖ [View IS61LF6436A-8.5TQLI-TR on WIN SOURCE](#)
- ⊖ [ISSI, Integrated Silicon Solution Inc Information](#)

## Optimize Your Supply Chain with WIN SOURCE Solutions

- ✓ Global Sourcing Solution
- ✓ Obsolete Management
- ✓ Cost Control Management
- ✓ Shortage Management
- ✓ Alternative Solution
- ✓ Excess Inventory Management