



# THE DATASHEET OF IRAM630-1562F2



Intelligent Power Module for  
 Energy Efficient Compressor  
 Applications

**15A, 600V IPM  
 with Integrated PFC  
 and Open Emitter Pins**

### Description

International Rectifier's IRAM630-1562F is a 15A, 600V PFC+Inverter Intelligent Power Module (IPM) with Open Emitter pins specifically designed for energy efficient Air Conditioners application. IR's technology offers an extremely compact, high performance compressor motor-driver with both PFC and Inverter stage in a single isolated package to simplify design.

This advanced IPM is a combination of IR's low  $V_{CE(on)}$  Trench IGBT technology and the industry benchmark 3 phase high voltage, high speed driver (3.3V compatible) in a fully isolated thermally enhanced package. A built-in high precision temperature monitor and over-current protection feature, along with the short-circuit rated IGBTs and integrated under-voltage lockout function, deliver high level of protection and fail-safe operation. Using a Single in line package with full transfer mold structure and CTI>600 minimizes PCB space and resolves isolation problems to heatsink.

### Features

- Integrated boost PFC power stage and gate driver
- Integrated gate drivers and bootstrap circuits
- Temperature monitor
- Protection shutdown pin
- Low  $V_{CE(on)}$  Trench IGBT technology
- Undervoltage lockout for all channels
- Matched propagation delay for all channels
- 3.3V Schmitt-triggered input logic
- Cross-conduction prevention logic
- Motor Power range up to 2kW / 85~253 Vac
- Isolation 2000VRMS min and CTI> 600
- RoHS Compliant
- Recognized by UL (File Number: E252584)

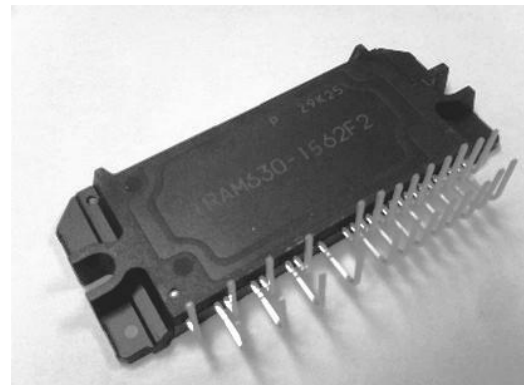

### Absolute Maximum Ratings

$V_{CES} / V_{RRM}$	IGBT/ FW Diode Blocking Voltage	600	V
$V_{AC}$	AC Input Voltage	253	$V_{RMS}$
$V^+$	Positive Bus Voltage	450	V
$I_{in} @ T_C=25^\circ C$	PFC RMS Current at $F_{PWM}=20kHz$	20	A
$I_{in} @ T_C=100^\circ C$	PFC RMS Current at $F_{PWM}=20kHz$	10	
$I_{pk\_PFC}$	PFC Maximum Peak Phase Current (Note 1)	30	
$F_{p\_PFC}$	PFC Maximum PWM Carrier Frequency	20	kHz
$P_{d\_PFC}$	PFC Maximum Power dissipation per IGBT @ $T_C = 25^\circ C$	62	W

Note 1:  $t_p < 100ms$ ,  $V_{CC} = 15V$ ,  $T_C = 25^\circ C$ ,  $F_{PWM} = 20kHz$ .



$T_J$ (IGBT & Diode & IC)	Maximum Operating Junction Temperature	+150	°C
$T_C$	Operating Case Temperature Range	-20 to +100	
$T_{STG}$	Storage Temperature Range	-40 to +125	
$T$	Mounting torque Range (M3 screw)	0.8 to 1.0	Nm

Note 1:  $t_p < 100\text{ms}$ ,  $V_{CC} = 15\text{V}$ ,  $T_C = 25^\circ\text{C}$ ,  $F_{PWM} = 20\text{kHz}$ .

Note 2: Sinusoidal Modulation at  $V^+ = 400\text{V}$ ,  $V_{CC} = 15\text{V}$ ,  $T_J = 150^\circ\text{C}$ ,  $MI = 0.8$ ,  $PF = 0.6$ , See Figure 4.

Note 3:  $t_p < 100\text{ms}$ ,  $V_{CC} = 15\text{V}$ ,  $T_C = 25^\circ\text{C}$ ,  $F_{PWM} = 6\text{kHz}$ .

### Absolute Maximum Ratings (Continued)

Symbol	Parameter	Min	Max	Units	Conditions
$V_{S1,2,3}$	High side floating supply offset voltage	$V_{B1,2,3} - 20$	$V_{B1,2,3} + 0.3$	V	
$V_{B1,2,3}$	High side floating supply voltage	-0.3	600	V	
$V_{CC}$	Low Side and logic fixed supply voltage	-0.3	20	V	
$V_{IN}$	Input voltage LIN, HIN, PFCIN, $I_{TRIP}$ , FLT/EN	-0.3	Lower of $(V_{SS} + 15\text{V})$ or $V_{CC} + 0.3\text{V}$	V	
$V_{PFC_{TRIP}}$	PFC <sub>TRIP</sub> input voltage	-2	Lower of $(V_{SS} + 15\text{V})$ or $V_{CC} + 0.3\text{V}$	V	

### PFC Section Electrical Characteristics

 $V_{BIAS} (V_{CC}, V_{BS1,2,3})=15V, T_J=25^{\circ}C$ , unless otherwise specified.

Symbol	Parameter	Min	Typ	Max	Units	Conditions
$V_{(BR)CES}$	Collector-to-Emitter Breakdown Voltage	600	---	---	V	$V_{IN}=0V, I_C=250\mu A$
$\Delta V_{(BR)CES} / \Delta T$	Temperature Coeff. Of Breakdown Voltage	---	0.3	---	V/ $^{\circ}C$	$V_{IN}=0V, I_C=1mA$ ( $25^{\circ}C - 150^{\circ}C$ )
$V_{CE(ON)}$	Collector-to-Emitter Saturation Voltage	---	1.15	1.4	V	$I_C=10A, T_J=25^{\circ}C$
		---	1.25	---		$I_C=10A, T_J=150^{\circ}C$
$I_{CES}$	Zero Gate Voltage Collector Current	---	10	150	$\mu A$	$V_{IN}=0V, V^+=600V$
		---	100	---		$V_{IN}=0V, V^+=600V, T_J=150^{\circ}C$
$V_{FM}$	Diode D8 Forward Voltage Drop	--	1.75	2.2	V	$I_F=10A$
		---	1.25	---		$I_F=10A, T_J=150^{\circ}C$
$V_{FM}$	Diode D7 Forward Voltage Drop	---	1.95	---	V	$I_F=3.5A$

### PFC Section Switching Characteristics

 $V_{BIAS} (V_{CC}, V_{BS1,2,3})=15V, T_J=25^{\circ}C$ , unless otherwise specified.

Symbol	Parameter	Min	Typ	Max	Units	Conditions
$E_{ON}$	Turn-On Switching Loss	---	540	700	$\mu J$	$I_C=10A, V^+=400V$ $V_{CC}=15V, L=1.2mH$ Energy losses include "tail" and diode reverse recovery
$E_{OFF}$	Turn-Off Switching Loss	---	220	350		
$E_{TOT}$	Total Switching Loss	---	760	1050		
$E_{REC}$	Diode Reverse Recovery energy	---	15	35		
$t_{RR}$	Diode Reverse Recovery time	---	140	---	ns	See CT1
$E_{ON}$	Turn-on Switching Loss	---	930	---	$\mu J$	$I_C=10A, V^+=400V$ $V_{CC}=15V, L=1.2mH, T_J=150^{\circ}C$ Energy losses include "tail" and diode reverse recovery
$E_{OFF}$	Turn-off Switching Loss	---	310	---		
$E_{TOT}$	Total Switching Loss	---	1240	---		
$E_{REC}$	Diode Reverse Recovery energy	---	75	---		
$t_{RR}$	Diode Reverse Recovery time	---	180	---	ns	See CT1
$Q_G$	Turn-On IGBT Gate Charge	---	95	140	nC	$I_C=48A, V^+=400V, V_{GE}=15V$
RBSOA	Reverse Bias Safe Operating Area	FULL SQUARE				$T_J=150^{\circ}C, I_C=40A, V_P=600V$ $V^+=450V,$ $V_{GE}=+15V$ to 0V See CT3
SCSOA	Short Circuit Safe Operating Area	2	---	---	$\mu s$	$T_J=150^{\circ}C, V^+=360V,$ $V_{GE}=+15V$ to 0V

### Inverter Section Electrical Characteristics

$V_{BIAS} (V_{CC}, V_{BS1,2,3})=15V, T_J=25^{\circ}C$ , unless otherwise specified.

Symbol	Parameter	Min	Typ	Max	Units	Conditions
$V_{(BR)CES}$	Collector-to-Emitter Breakdown Voltage	600	---	---	V	$V_{IN}=0V, I_C=250\mu A$
$\Delta V_{(BR)CES} / \Delta T$	Temperature Coeff. Of Breakdown Voltage	---	0.3	---	V/ $^{\circ}C$	$V_{IN}=0V, I_C=250\mu A$ ( $25^{\circ}C - 150^{\circ}C$ )
$V_{CE(ON)}$	Collector-to-Emitter Saturation Voltage	---	1.5	1.7	V	$I_C=5A, T_J=25^{\circ}C$
		---	1.7	---		$I_C=5A, T_J=150^{\circ}C$
$I_{CES}$	Zero Gate Voltage Collector Current	---	5	80	$\mu A$	$V_{IN}=0V, V^+=600V$
		---	80	---		$V_{IN}=0V, V^+=600V, T_J=150^{\circ}C$
$V_{FM}$	Diode Forward Voltage Drop	--	1.8	2.35	V	$I_F=5A$
		---	1.45	---		$I_F=5A, T_J=150^{\circ}C$
$C_{1,2,3,4}$	$V_{CC} / V_{BS}$ Capacitor Value	---	47	---	nF	$T_J=25^{\circ}C$
$C_{6,7}$	Itrip / PFCTrip Capacitor Value	---	1	---	nF	$T_J=25^{\circ}C$

### Inverter Section Switching Characteristics

$V_{BIAS} (V_{CC}, V_{BS1,2,3})=15V, T_J=25^{\circ}C$ , unless otherwise specified.

Symbol	Parameter	Min	Typ	Max	Units	Conditions
$E_{ON}$	Turn-On Switching Loss	---	220	350	$\mu J$	$I_C=5A, V^+=400V$ $V_{CC}=15V, L=1.2mH$ Energy losses include "tail" and diode reverse recovery
$E_{OFF}$	Turn-Off Switching Loss	---	85	140		
$E_{TOT}$	Total Switching Loss	---	305	490		
$E_{REC}$	Diode Reverse Recovery energy	---	15	35		
$t_{RR}$	Diode Reverse Recovery time	---	115	---	ns	See CT1
$E_{ON}$	Turn-on Switching Loss	---	320	---	$\mu J$	$I_C=5A, V^+=400V$ $V_{CC}=15V, L=1.2mH, T_J=150^{\circ}C$ Energy losses include "tail" and diode reverse recovery
$E_{OFF}$	Turn-off Switching Loss	---	115	---		
$E_{TOT}$	Total Switching Loss	---	435	---		
$E_{REC}$	Diode Reverse Recovery energy	---	50	---		
$t_{RR}$	Diode Reverse Recovery time	---	160	---	ns	See CT1
$Q_G$	Turn-On IGBT Gate Charge	---	19	29	nC	$I_C=8A, V^+=400V, V_{GE}=15V$
RBSOA	Reverse Bias Safe Operating Area	FULL SQUARE				$T_J=150^{\circ}C, I_C=5A, V_P=600V$ $V^+=450V,$ $V_{CC}=+15V$ to 0V See CT3
SCSOA	Short Circuit Safe Operating Area	2	---	---	$\mu s$	$T_J=150^{\circ}C, V^+=360V,$ $V_{GE}=+17.5V$ to 0V

## Recommended Operating Conditions Driver Function

The Input/Output logic timing diagram is shown in Figure 1. For proper operation the device should be used within the recommended conditions. All voltages are absolute referenced to COM. The  $V_S$  offset is tested with all supplies biased at 15V differential (Note 4)

Symbol	Definition	Min	Typ	Max	Units
$V_{B1,2,3}$	High side floating supply voltage	$V_S+12.5$	$V_S+15$	$V_S+17.5$	V
$V_{S1,2,3}$	High side floating supply offset voltage	Note 5	---	450	V
$V_{CC}$	Low side and logic fixed supply voltage	13.5	15	16.5	V
$V_{IN}$	Logic input voltage LIN, HIN, PFCIN, $\overline{I_{TRIP}}$ , $\overline{FLT/EN}$	0	---	5	V
$V_{PFC_{TRIP}}$	PFC <sub>TRIP</sub> input voltage	-2	---	0	V
HIN	High side PWM pulse width	1	---	---	μs
Deadtime	External dead time between HIN and LIN	1	---	---	μs

Note 4: For more details, see IRS26302D data sheet

Note 5: Logic operational for  $V_S$  from COM-5V to COM+600V. Logic state held for  $V_S$  from COM-5V to COM- $V_{BS}$ . (please refer to DT97-3 for more details)

## Static Electrical Characteristics Driver Function

$V_{BIAS}$  ( $V_{CC}$ ,  $V_{BS1,2,3}$ )=15V,  $T_J=25^\circ\text{C}$ , unless otherwise specified. The  $V_{IN}$  and  $I_{IN}$  parameters are referenced to COM and are applicable to all six channels. (Note 4)

Symbol	Definition	Min	Typ	Max	Units
$V_{IN,th+}$	Positive going input threshold for LIN, HIN, PFCIN, $\overline{FLT/EN}$	2.5	---	---	V
$V_{IN,th-}$	Negative going input threshold for LIN, HIN, PFCIN, $\overline{FLT/EN}$	---	---	0.8	V
$V_{CCUV+}$ , $V_{BSUV+}$	$V_{CC}/V_{BS}$ supply undervoltage, Positive going threshold	10.2	11.1	12	V
$V_{CCUV-}$ , $V_{BSUV-}$	$V_{CC}/V_{BS}$ supply undervoltage, Negative going threshold	10	10.9	11.8	V
$V_{CCUVH}$ , $V_{BSUVH}$	$V_{CC}$ and $V_{BS}$ supply undervoltage lock-out hysteresis	---	0.2	---	V
$V(I_{TRIP})$	$I_{TRIP}$ threshold Voltage	0.4	0.5	0.6	V
$V(I_{TRIP}, HYS)$	$I_{TRIP}$ Input Hysteresis	---	0.05	---	V
$V(PFC_{TRIP})$	PFC <sub>TRIP</sub> threshold Voltage	-0.16	-0.2	-0.24	V
$V(PFC_{TRIP}, HYS)$	PFC <sub>TRIP</sub> Input Hysteresis	---	0.02	---	V
$I_{QBS}$	Quiescent $V_{BS}$ supply current	---	---	120	μA
$I_{QCC}$	Quiescent $V_{CC}$ supply current	---	---	4	mA
$I_{LK}$	Offset Supply Leakage Current	---	---	50	μA
$I_{IN+}$	Input bias current $V_{IN}=3.3\text{V}$ for LIN, HIN, PFCIN, $\overline{FLT/EN}$	350	--	860	μA
$I_{IN-}$	Input bias current $V_{IN}=0\text{V}$ for LIN, HIN, PFCIN, $\overline{FLT/EN}$	--	0	1	μA
$I_{TRIP+}$	$I_{TRIP}$ bias current $V_{T/ITRIP}=3.3\text{V}$	---	1	2	μA
$I_{TRIP-}$	$I_{TRIP}$ bias current $V_{T/ITRIP}=0\text{V}$	---	0	5	μA
$PFC_{TRIP+}$	PFC $I_{TRIP}$ bias current $V_{PFC\_ITRIP}=-250\text{mV}$	---	20	---	μA
$PFC_{TRIP-}$	PFC $I_{TRIP}$ bias current $V_{PFC\_ITRIP}=0\text{V}$	---	0	5	μA
$R_{on\_FLT}$	Fault low on resistance	---	50	100	Ω
$R_{BS}$	Internal bootstrap FET on resistance	---	200	400	Ω

## Dynamic Electrical Characteristics

$V_{BIAS}$  ( $V_{CC}$ ,  $V_{BS1,2,3}$ )=15V,  $T_J$ =25°C, unless otherwise specified. Driver only timing unless otherwise specified.

Symbol	Parameter	Min	Typ	Max	Units	Conditions
$T_{ON}$	Input to Output propagation turn-on delay time (see fig.11)	---	---	1.15	$\mu$ s	$I_C=5A$ , $V^+=400V$
$T_{OFF}$	Input to Output propagation turn-off delay time (see fig. 11)	---	---	1.15	$\mu$ s	
$T_{FILIN}$	Input filter time (HIN,LIN,PFC,EN)	200	350	---	ns	$V_{IN}=0$ or $V_{IN}=3.3V$
$T_{FILEN}$	Input filter time ( $\overline{FLT}$ /EN)	100	200	---	ns	$V_{IN}=0$ or $V_{IN}=5V$
$T_{EN}$	EN low to six switch turn-off propagation delay (see fig. 3)	---	---	1.15	$\mu$ s	$V_{IN}=0$ or $V_{IN}=3.3V$ , $V_{EN}=0$
$T_{FLT}$	$I_{TRIP}$ to Fault propagation delay	---	800	---	ns	$V_{IN}=0$ or $V_{IN}=3.3V$ , $V_{ITRIP}=3.3V$
$T_{BLT-ITRIP}$	$I_{TRIP}$ Blanking Time	---	500	---	ns	$V_{IN}=0$ or $V_{IN}=3.3V$ , $V_{ITRIP}=3.3V$
$T_{ITRIP}$	$I_{TRIP}$ to six switch turn-off propagation delay (see fig. 2)	---	---	1.5	$\mu$ s	$I_C=5A$ , $V^+=400V$
$T_{PFCTRIP}$	$PFC_{TRIP}$ to switch turn-off propagation delay (see fig. 2)	---	---	1.5	$\mu$ s	$I_C=10A$ , $V^+=400V$
$D_T$	Internal Dead Time injected by driver	190	290	420	ns	$V_{IN}=0$ or $V_{IN}=3.3V$
$M_T$	Matching Propagation Delay Time (On & Off) all channels	---	---	50	ns	External dead time > 400ns
$T_{FLT-CLR}$	Post $I_{TRIP}$ to six switch turn-off clear time (see fig. 2)	1.17	1.7	2.19	ms	$T_C = 25^\circ C$
		---	1.5	---		$T_C = 100^\circ C$

### Thermal and Mechanical Characteristics

Symbol	Parameter	Min	Typ	Max	Units	Conditions
$R_{th(J-C)}$	Thermal resistance, PFC IGBT	---	1.6	2.0	°C/W	Inverter Operating Condition Flat, greased surface. Heatsink compound thermal conductivity 1W/mK
$R_{th(J-C)}$	Thermal resistance, PFC Diode	---	3.0	3.6		
$R_{th(J-C)}$	Thermal resistance, per IGBT	---	3.8	4.6		
$R_{th(J-C)}$	Thermal resistance, per Diode	---	5.8	6.9		
$R_{th(C-S)}$	Thermal resistance, C-S	---	0.1	---		
CTI	Comparative Tracking Index	600	---	---	V	

### Internal NTC - Thermistor Characteristics

Parameter	Definition	Min	Typ	Max	Units	Conditions
$R_{25}$	Resistance	44.65	47	49.35	k $\Omega$	$T_C = 25^\circ\text{C}$
$R_{125}$	Resistance	1.27	1.41	1.56	k $\Omega$	$T_C = 125^\circ\text{C}$
B	B-constant (25-50°C)	3989	4050	4111	k	$R_2 = R_1 e^{[B(1/T_2 - 1/T_1)]}$
Temperature Range		-40	---	125	°C	
Typ. Dissipation constant		---	1	---	mW/°C	$T_C = 25^\circ\text{C}$

### Input-Output Logic Level Table

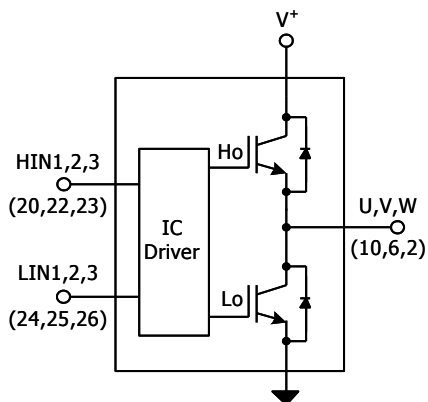

$\overline{\text{FLT/EN}}$	$I_{\text{TRIP}}$	HIN1,2,3	LIN1,2,3	U,V,W
1	0	1	0	V+
1	0	0	1	0
1	0	0	0	Off
1	0	1	1	Off
1	1	X	X	Off
0	X	X	X	Off

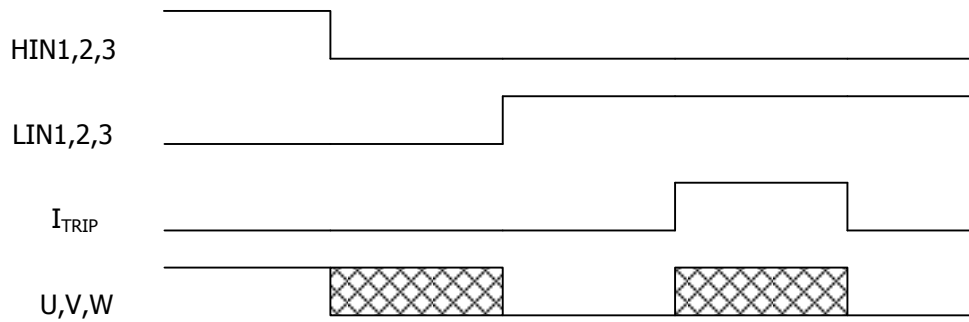

Figure 1. Input/Output Timing Diagram

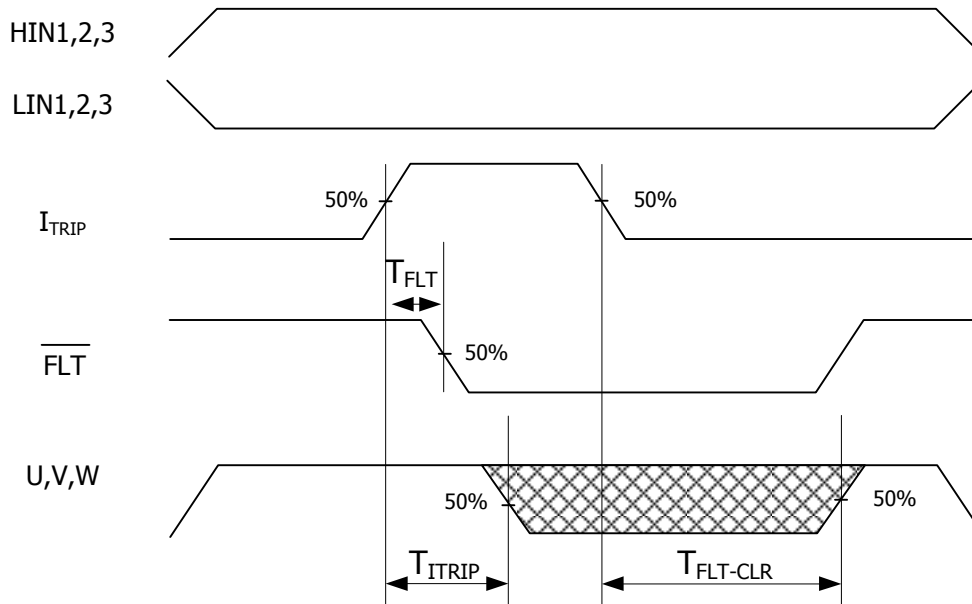

Figure 2.  $I_{TRIP}$  Timing Waveform

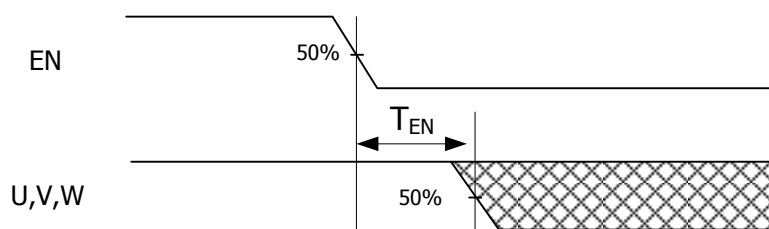
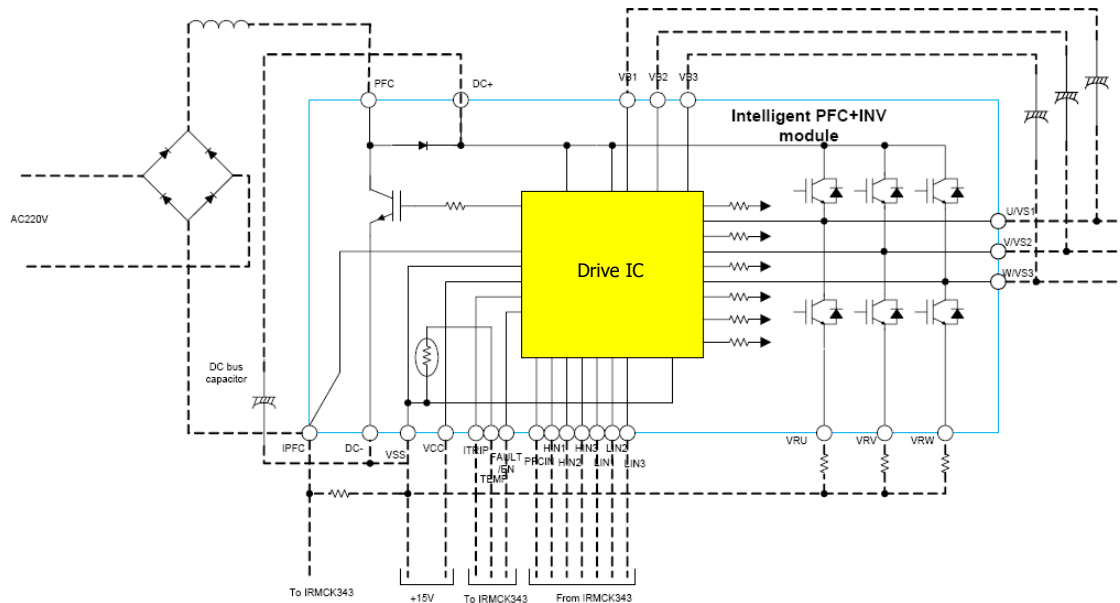

Figure 3. Output Enable Timing Diagram

Note 6: The shaded area indicates that both high-side and low-side switches are off and therefore the half-bridge output voltage would be determined by the direction of current flow in the load.

**Module Pin-Out Description**

Pin	Name	Description
1	PFC	PFC
2	na	none
3	na	none
4	VB3	High Side Floating Supply Voltage 3
5	W,VS3	Output 3 - High Side Floating Supply Offset Voltage
6	na	none
7	na	none
8	VB2	High Side Floating Supply voltage 2
9	V,VS2	Output 2 - High Side Floating Supply Offset Voltage
10	na	none
11	na	none
12	VB1	High Side Floating Supply voltage 1
13	U,VS1	Output 1 - High Side Floating Supply Offset Voltage
14	na	none
15	na	none
16	V <sup>+</sup>	Positive Bus Input Voltage
17	na	none
18	na	none
19	V <sup>-</sup>	Negative Bus Input Voltage
20	VRW	Low Side Emitter Connection - Phase 3
21	VRV	Low Side Emitter Connection - Phase 2
22	VRU	Low Side Emitter Connection - Phase 1
23	HIN1	Logic Input High Side Gate Driver - Phase 1
24	HIN2	Logic Input High Side Gate Driver - Phase 2
25	HIN3	Logic Input High Side Gate Driver - Phase 3
26	LIN1	Logic Input Low Side Gate Driver - Phase 1
27	LIN2	Logic Input Low Side Gate Driver - Phase 2
28	LIN3	Logic Input Low Side Gate Driver - Phase 3
29	PFCIN	PFC input
30	$\overline{\text{FLT/EN}}$	Fault Output and Enable Pin
31	PFC <sub>TRIP</sub>	Current Protection Pin for PFC
32	I <sub>TRIP</sub>	Current Protection Pin for Inverter
33	V <sub>TH</sub>	Temperature Feedback
34	V <sub>CC</sub>	+15V Main Supply
35	V <sub>SS</sub>	Negative Main Supply

**Typical Application Connection IRAM630-1562F**

1. Electrolytic bus capacitors should be mounted as close to the module bus terminals as possible to reduce ringing and EMI problems. Additional high frequency ceramic capacitor mounted close to the module pins will further improve performance.
2. In order to provide good decoupling between VCC-VSS and VB1,2,3-VS1,2,3 terminals, the capacitors shown connected between these terminals should be located very close to the module pins. Additional high frequency capacitors, typically 0.1 $\mu$ F, are strongly recommended.
3. Value of the boot-strap capacitors depends upon the switching frequency. Their selection should be made based on IR design tip DT04-4, application note AN-1044 or Figure 11. Bootstrap capacitor value must be selected to limit the power dissipation of the internal resistor in series with the VCC. (see maximum ratings Table on page 3).
4. After approx. 2ms the FAULT is reset. (see Dynamic Characteristics Table on page 5).
5. PWM generator must be disabled within Fault duration to guarantee shutdown of the system, overcurrent condition must be cleared before resuming operation.

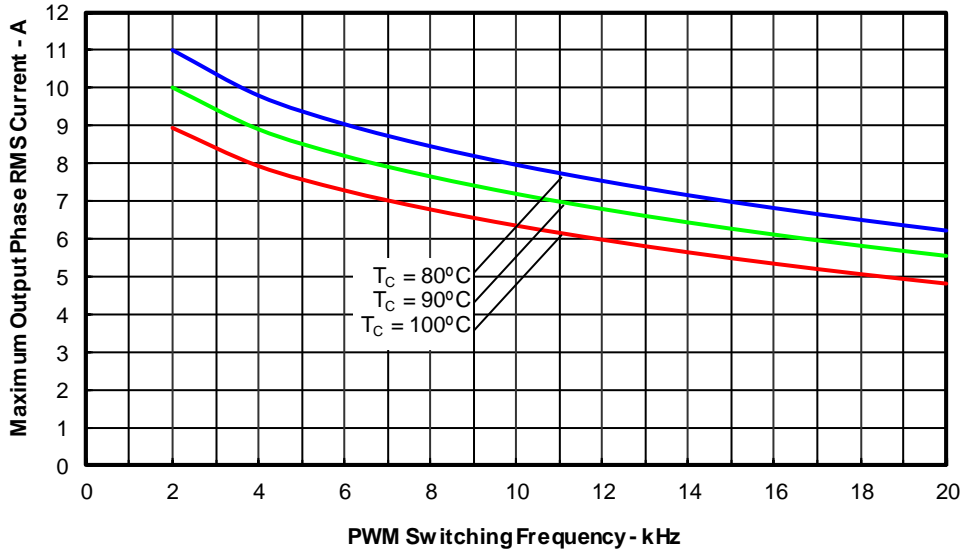

Figure 4. Maximum Sinusoidal Phase Current vs. PWM Switching Frequency  
Sinusoidal Modulation,  $V^+=400V$ ,  $T_J=150^\circ C$ ,  $MI=0.8$ ,  $PF=0.6$ ,  $f_{mod}=50Hz$

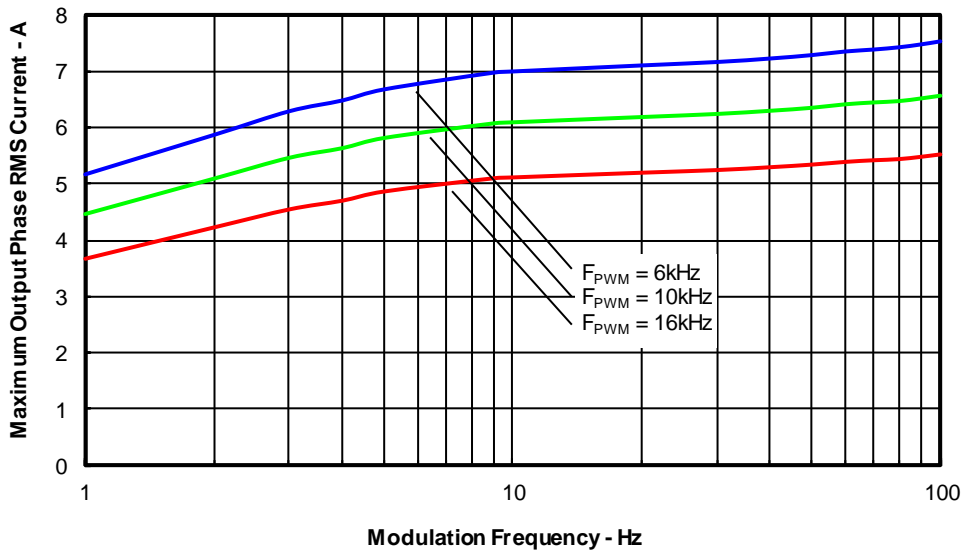

Figure 5. Maximum Sinusoidal Phase Current vs. Modulation Frequency  
Sinusoidal Modulation,  $V^+=400V$ ,  $T_J=150^\circ C$ ,  $T_C=100^\circ C$ ,  $MI=0.8$ ,  $PF=0.6$

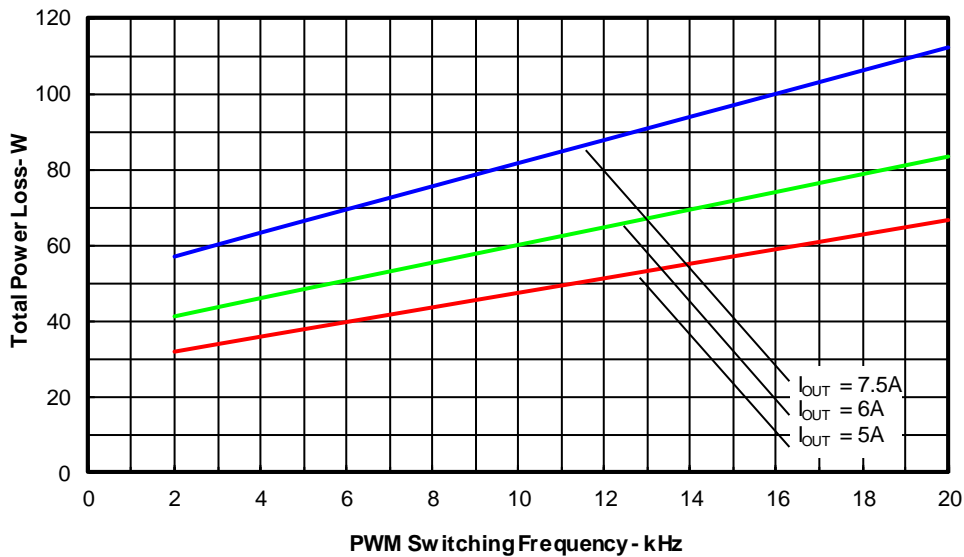

Figure 6. Total Power Losses vs. PWM Switching Frequency  
 Sinusoidal Modulation,  $V^+ = 400V$ ,  $T_J = 150^\circ C$ ,  $MI = 0.8$ ,  $PF = 0.6$ ,  $f_{mod} = 50Hz$

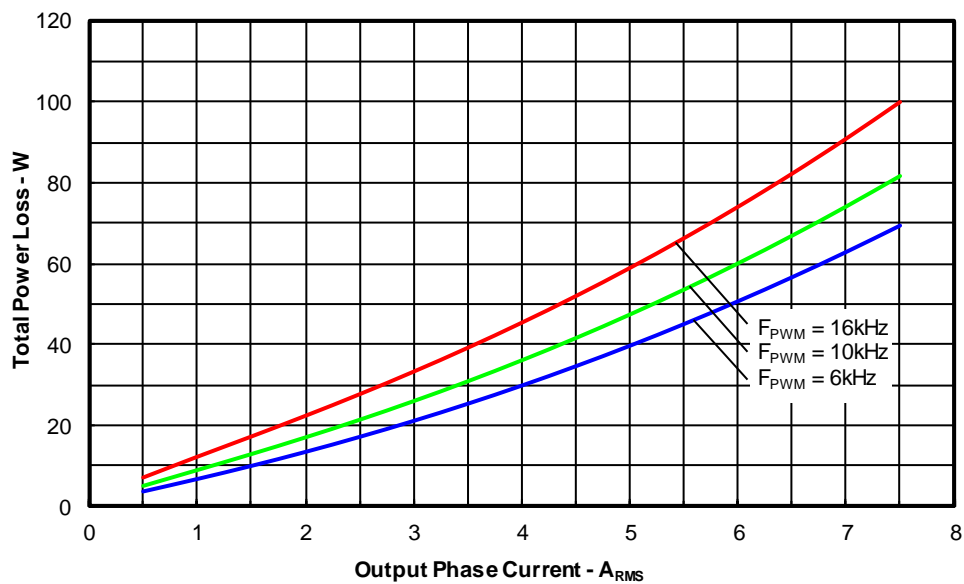

Figure 7. Total Power Losses vs. Output Phase Current  
 Sinusoidal Modulation,  $V^+ = 400V$ ,  $T_J = 150^\circ C$ ,  $MI = 0.8$ ,  $PF = 0.6$ ,  $f_{mod} = 50Hz$

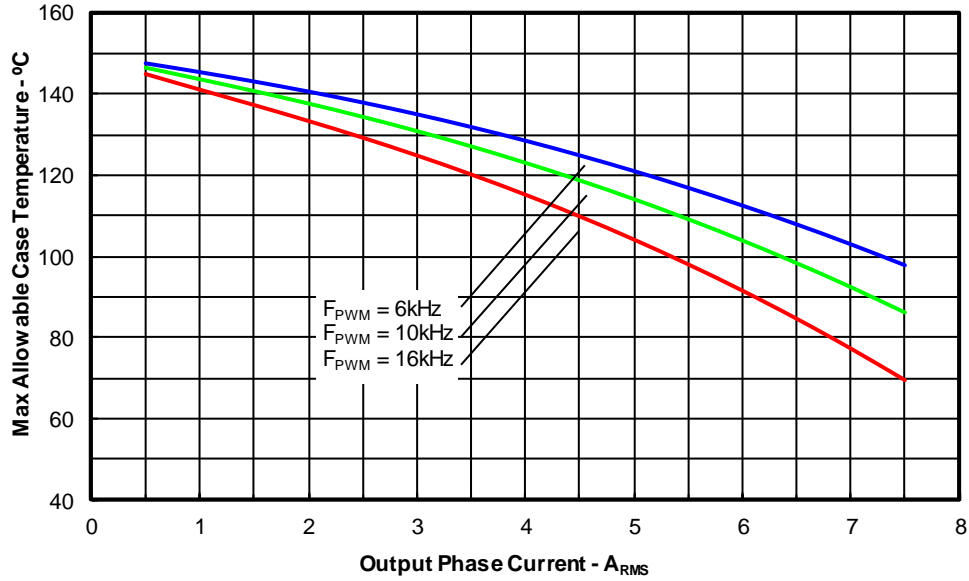

Figure 8. Maximum Allowable Case Temperature vs. Output RMS Current per Phase Sinusoidal Modulation,  $V^+=400V$ ,  $T_J=150^\circ C$ ,  $MI=0.8$ ,  $PF=0.6$ ,  $f_{mod}=50Hz$

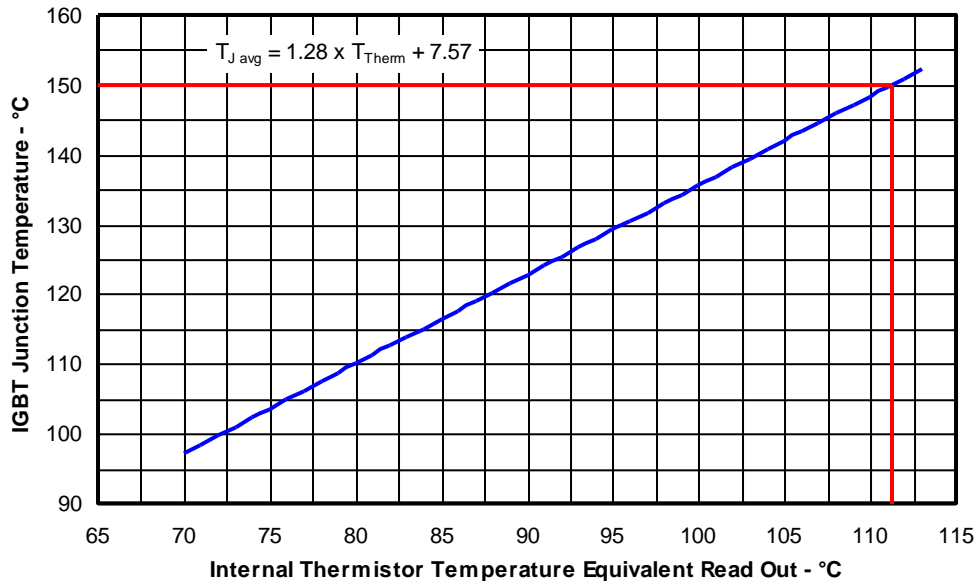

Figure 9. Estimated Maximum IGBT Junction Temperature vs. Thermistor Temperature Sinusoidal Modulation,  $V^+=400V$ ,  $I_{phase}=5A_{rms}$ ,  $f_{sw}=16kHz$ ,  $f_{mod}=50Hz$ ,  $MI=0.8$ ,  $PF=0.6$

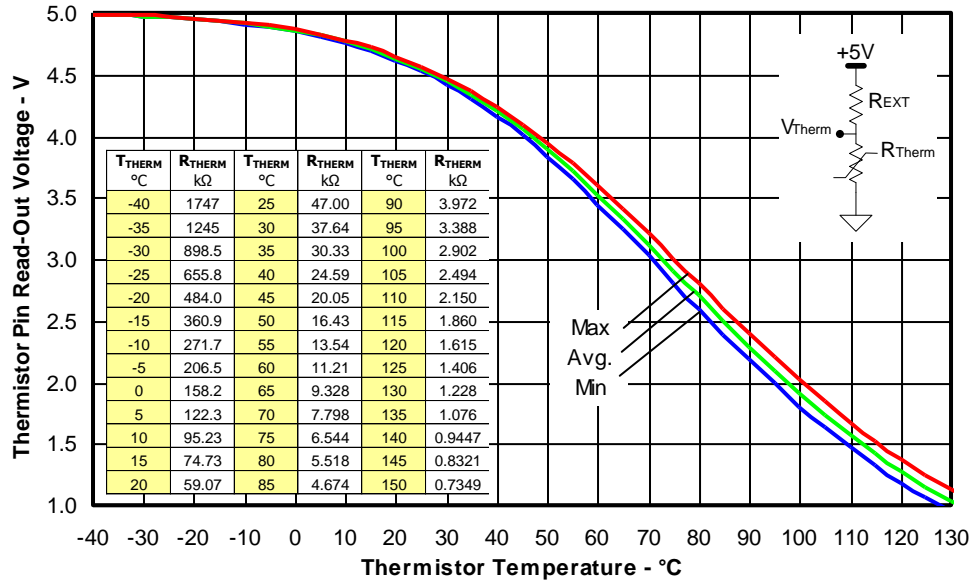

Figure 10. Thermistor Readout vs. Temperature (4.7kohm pull-up resistor, 5V) and Normal Thermistor Resistance values vs. Temperature Table.

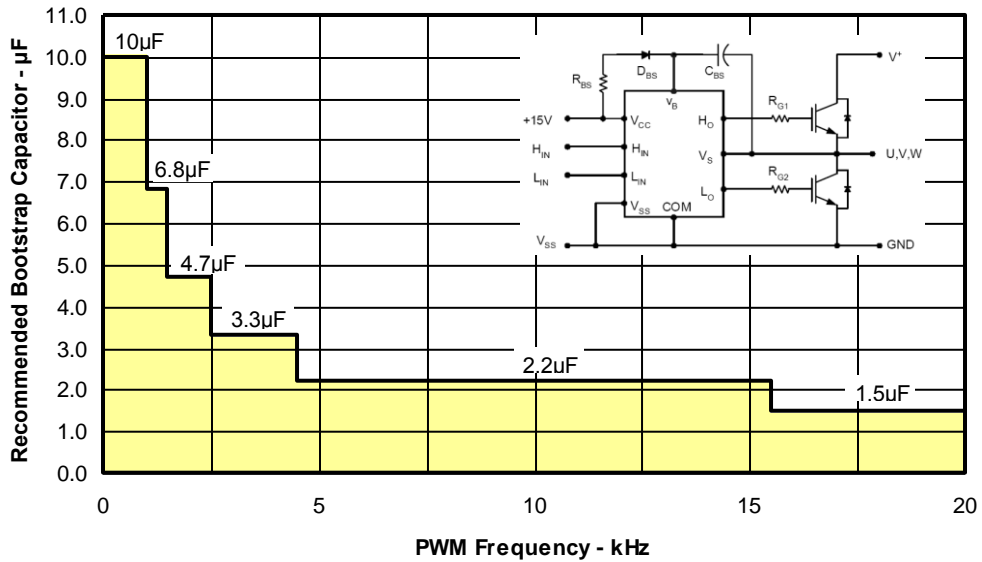

Figure 11. Recommended Bootstrap Capacitor Value vs. Switching Frequency

Figure 12. Switching Parameter Definitions

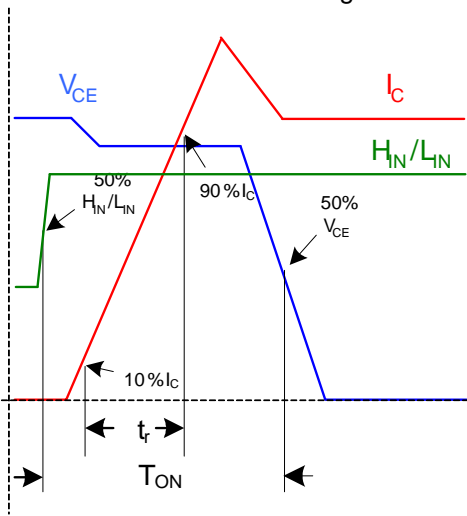

Figure 12a. Input to Output propagation turn-on delay time.

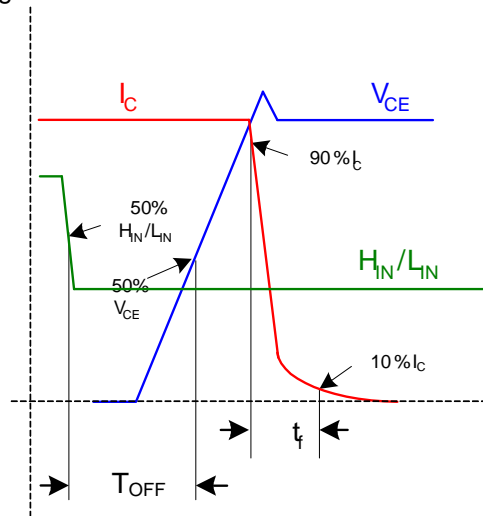

Figure 12b. Input to Output propagation turn-off delay time.

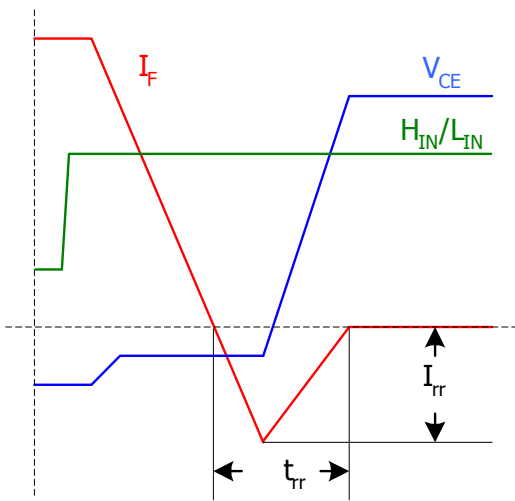

Figure 12c. Diode Reverse Recovery.

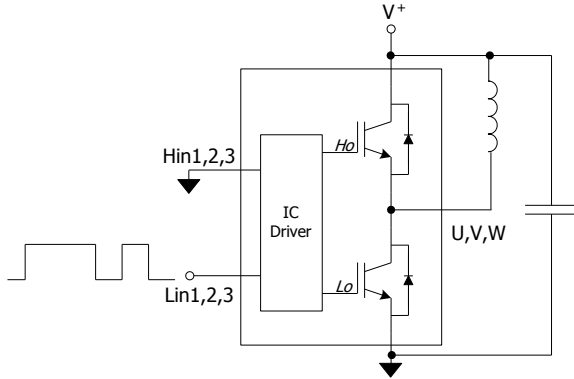

Figure CT1. Switching Loss Circuit

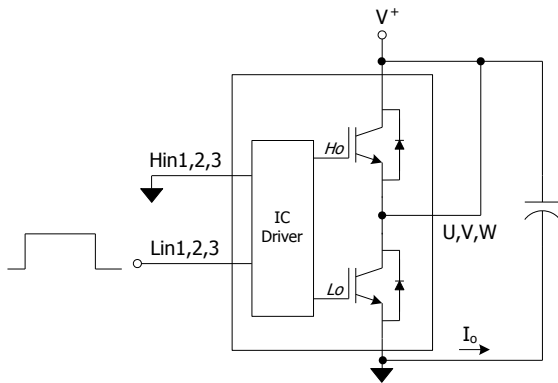
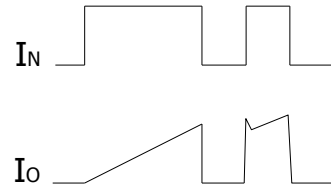

Figure CT2. S.C.SOA Circuit

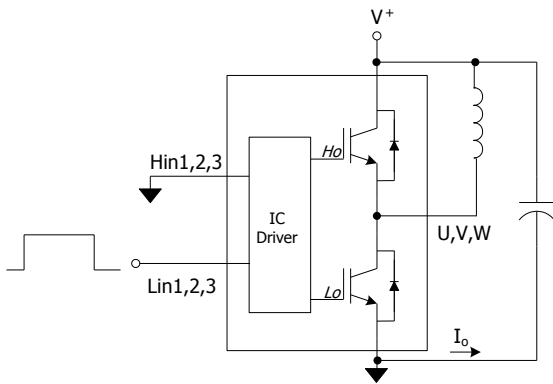
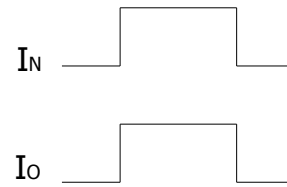
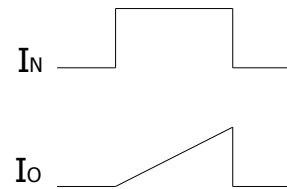
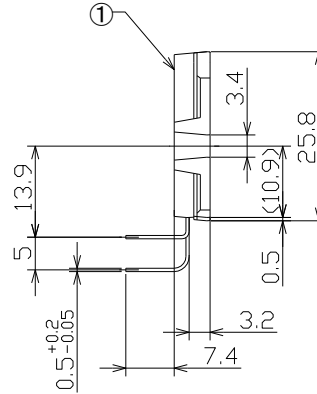
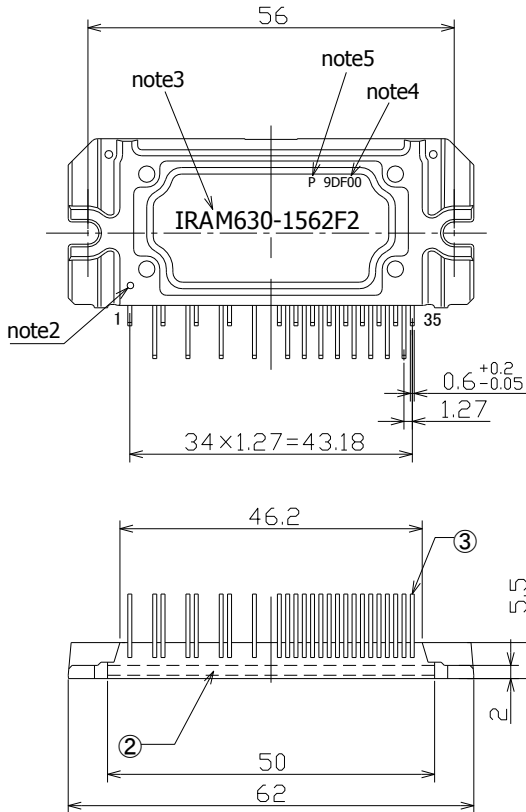

Figure CT3. R.B.SOA Circuit



**Package Outline IRAM630-1562F2**

missing pin : 2,3,6,7,10,11,14,15,17,18



- note1: Unit Tolerance is +0.5mm, Unless Otherwise Specified.
- note2: Mirror Surface Mark indicates Pin1 Identification.
- note3: Part Number Marking. Characters Font in this drawing differs from Font shown on Module.
- note4: Lot Code Marking. Characters Font in this drawing differs from Font shown on Module.
- note5: "P" Character denotes Lead Free. Characters Font in this drawing differs from Font shown on Module.

Dimensions in mm  
For mounting instruction see AN-1049



## Looking for pricing, stock, or lifecycle information?

Click below to explore more details on WIN SOURCE:

 [View IRAM630-1562F2 on WIN SOURCE](#)

 [Infineon Technologies](#) Information

## Optimize Your Supply Chain with WIN SOURCE Solutions

-  Global Sourcing Solution
-  Obsolete Management
-  Cost Control Management
-  Shortage Management
-  Alternative Solution
-  Excess Inventory Management