

International
IR Rectifier

Integrated Power Hybrid IC for
High Voltage Motor Applications

IRAM136-3063B
iMOTION™ Series
30A, 600V
with Internal Shunt Resistor

Description

International Rectifier's IRAM136-3063B is a 30A, 600V Integrated Power Hybrid IC with Internal Shunt Resistor for Appliance Motor Drives applications such air conditioning systems and compressor drivers as well as for light industrial application. IR's technology offers an extremely compact, high performance AC motor driver in a single isolated package to simplify design.

This advanced HIC is a combination of IR's low $V_{CE(on)}$ Punch-Through IGBT technology and the industry benchmark 3-Phase high voltage, high speed driver in a fully isolated thermally enhanced package. A built-in temperature monitor and over-current and over-temperature protections, along with the short-circuit rated IGBTs and integrated under-voltage lockout function, deliver high level of protection and failsafe operation. Using a new developed single in line package (SiP3) with heat spreader for the power die along with full transfer mold structure minimizes PCB space and resolves isolation problems to heatsink.

Features

- Integrated Gate Drivers
- Temperature Monitor and Protection
- Overcurrent shutdown
- Low $V_{CE(on)}$ Advance Planar Super Rugged Technology
- Undervoltage lockout for all channels
- Matched propagation delay for all channels
- 5V Schmitt-triggered input logic
- Cross-conduction prevention logic
- Lower di/dt gate driver for better noise immunity
- Motor Power up to 3.3kW / 85~253 Vdc
- Fully Isolated Package, Isolation 2000V_{RMS} min

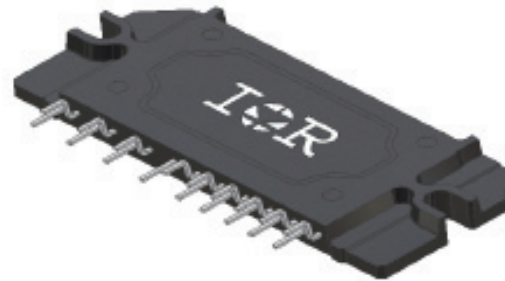

Absolute Maximum Ratings

Parameter	Description	Value	Units
V_{CES} / V_{RRM}	IGBT/Diode Blocking Voltage	600	V
V^+	Positive Bus Input Voltage	450	
$I_O @ T_C=25^\circ\text{C}$	Maximum Output Current	30	A
$I_O @ T_C=100^\circ\text{C}$	RMS Phase Current (Note 1)	15	
I_O	Pulsed RMS Phase Current (Note 2)	50	
F_{PWM}	PWM Carrier Frequency	20	kHz
P_D	Power dissipation per IGBT @ $T_C = 25^\circ\text{C}$	73	W
V_{ISO}	Isolation Voltage (1min)	2000	V _{RMS}
T_J (IGBT & Diode & IC)	Maximum Operating Junction Temperature	+150	°C
T_C	Operating Case Temperature Range	-20 to +100	
T_{STG}	Storage Temperature Range	-40 to +125	
T	Mounting torque Range (M4 screw)	0.7 to 1.17	
			Nm

Note 1: Sinusoidal Modulation at $V^+=400\text{V}$, $T_J=150^\circ\text{C}$, $F_{PWM}=6\text{kHz}$, Modulation Depth=0.8, PF=0.6, See Figure 3.

Note 2: $t_p < 100\text{ms}$; $T_C=25^\circ\text{C}$; $F_{PWM}=6\text{kHz}$. Limited by $I_{BUS-ITRIP}$, see Table "Inverter Section Electrical Characteristics"

IRAM136-3063B

Internal Electrical Schematic – IRAM136-3063B

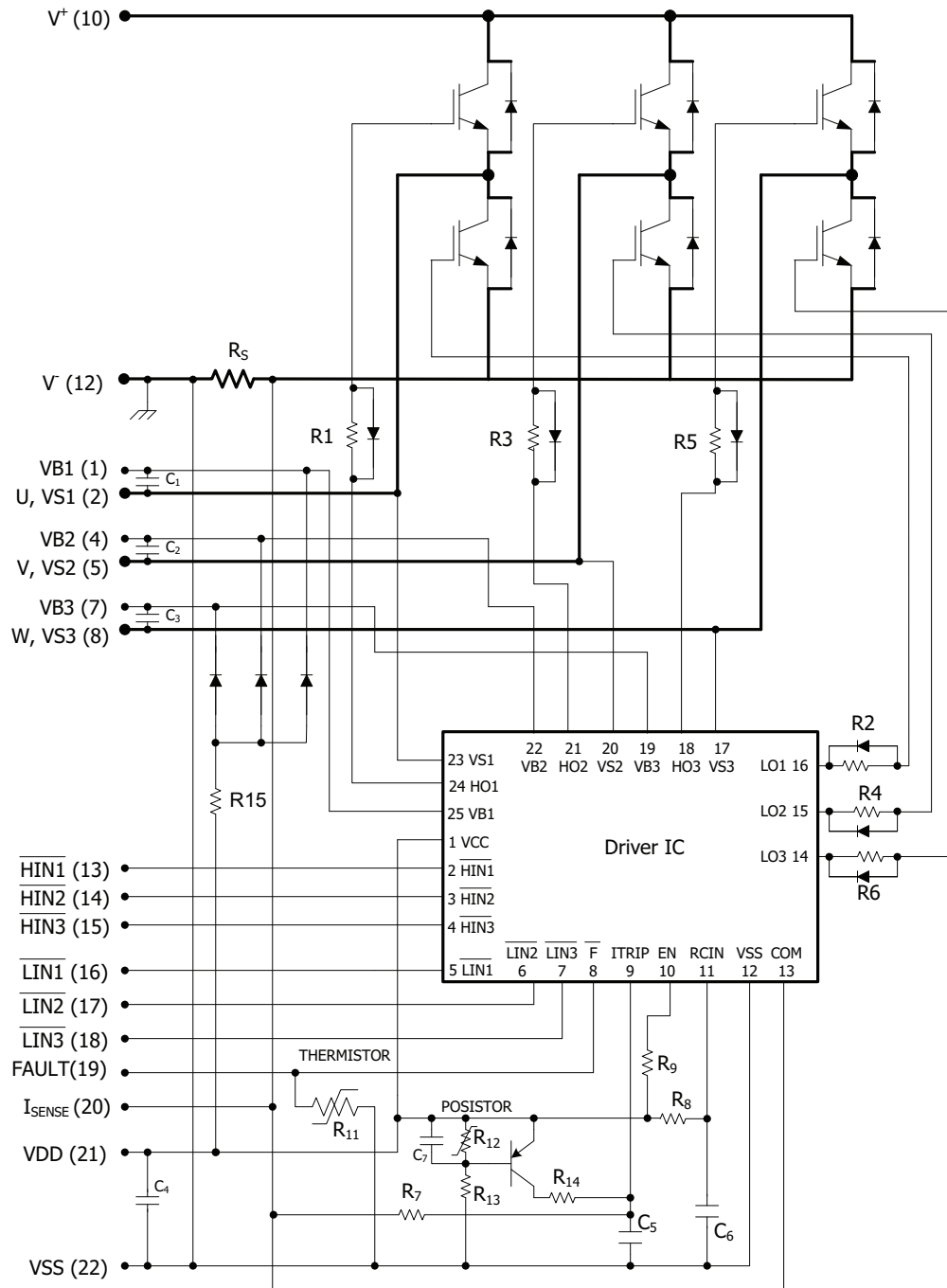

Absolute Maximum Ratings (Continued)

Symbol	Parameter	Min	Max	Units	Conditions
I_{BDF}	Bootstrap Diode Peak Forward Current	---	4.5	A	$t_p=10\text{ms}$, $T_J=150^\circ\text{C}$, $T_C=100^\circ\text{C}$
$P_{BR\text{ Peak}}$	Bootstrap Resistor Peak Power (Single Pulse)	---	25.0	W	$t_p=100\mu\text{s}$, $T_C=100^\circ\text{C}$
$V_{S1,2,3}$	High side floating supply offset voltage	$V_{B1,2,3} - 25$	$V_{B1,2,3} + 0.3$	V	
$V_{B1,2,3}$	High side floating supply voltage	-0.3	600	V	
V_{CC}	Low Side and logic fixed supply voltage	-0.3	20	V	
V_{IN}	Input voltage LIN, HIN, I_{Trip}	-0.3	Lower of ($V_{SS}+15\text{V}$) or $V_{CC}+0.3\text{V}$	V	

Inverter Section Electrical Characteristics @ $T_J=25^\circ\text{C}$

Symbol	Parameter	Min	Typ	Max	Units	Conditions
$V_{(BR)CES}$	Collector-to-Emitter Breakdown Voltage	600	---	---	V	$V_{IN}=5\text{V}$, $I_C=500\mu\text{A}$
$\Delta V_{(BR)CES} / \Delta T$	Temperature Coeff. Of Breakdown Voltage	---	0.5	---	V/ $^\circ\text{C}$	$V_{IN}=5\text{V}$, $I_C=1.0\text{mA}$ ($25^\circ\text{C} - 150^\circ\text{C}$)
$V_{CE(ON)}$	Collector-to-Emitter Saturation Voltage	---	1.90	2.7	V	$I_C=15\text{A}$, $V_{CC}=15\text{V}$
		---	2.10	2.8		$I_C=15\text{A}$, $V_{CC}=15\text{V}$, $T_J=125^\circ\text{C}$
I_{CES}	Zero Gate Voltage Collector Current	---	5	150	μA	$V_{IN}=5\text{V}$, $V^+=600\text{V}$
		---	80	---		$V_{IN}=5\text{V}$, $V^+=600\text{V}$, $T_J=125^\circ\text{C}$
V_{FM}	Diode Forward Voltage Drop	---	1.6	2.5	V	$I_C=15\text{A}$
		---	1.5	2.2		$I_C=15\text{A}$, $T_J=125^\circ\text{C}$
V_{BDFM}	Bootstrap Diode Forward Voltage Drop	--	--	1.25	V	$I_F=1\text{A}$
		---	---	1.10		$I_F=1\text{A}$, $T_J=125^\circ\text{C}$
R_{BR}	Bootstrap Resistor Value	---	22	---	Ω	$T_J=25^\circ\text{C}$
$\Delta R_{BR}/R_{BR}$	Bootstrap Resistor Tolerance	---	---	± 5	%	$T_J=25^\circ\text{C}$
I_{BUS_TRIP}	Current Protection Threshold (positive going)	44	---	58	A	$t_{ON} > 175\mu\text{s}$

Inverter Section Switching Characteristics @ $T_J = 25^\circ\text{C}$

Symbol	Parameter	Min	Typ	Max	Units	Conditions
E_{ON}	Turn-On Switching Loss	---	550	870	μJ	$I_C=15\text{A}$, $V^+=400\text{V}$ $V_{CC}=15\text{V}$, $L=2\text{mH}$ Energy losses include "tail" and diode reverse recovery
E_{OFF}	Turn-Off Switching Loss	---	240	300		
E_{TOT}	Total Switching Loss	---	790	1170		
E_{REC}	Diode Reverse Recovery energy	---	65	125		
t_{RR}	Diode Reverse Recovery time	---	50	---	ns	See CT1
E_{ON}	Turn-On Switching Loss	---	830	1180	μJ	$I_C=15\text{A}$, $V^+=400\text{V}$ $V_{CC}=15\text{V}$, $L=2\text{mH}$, $T_J=125^\circ\text{C}$ Energy losses include "tail" and diode reverse recovery
E_{OFF}	Turn-off Switching Loss	---	400	550		
E_{TOT}	Total Switching Loss	---	1230	1730		
E_{REC}	Diode Reverse Recovery energy	---	120	205		
t_{RR}	Diode Reverse Recovery time	---	140	---	ns	See CT1
Q_G	Turn-On IGBT Gate Charge	---	72	108	nC	$I_C=20\text{A}$, $V^+=400\text{V}$, $V_{GE}=15\text{V}$
RBSOA	Reverse Bias Safe Operating Area	FULL SQUARE				$T_J=150^\circ\text{C}$, $I_C=60\text{A}$, $V_p=600\text{V}$ $V^+=480\text{V}$ $V_{CC}=+15\text{V}$ to 0V See CT3
SCSOA	Short Circuit Safe Operating Area	10	---	---	μs	$T_J=150^\circ\text{C}$, $V_p=600\text{V}$, $V^+=500\text{V}$, $V_{CC}=+15\text{V}$ to 0V See CT2

Recommended Operating Conditions Driver Function

The Input/Output logic timing diagram is shown in Figure 1. For proper operation the device should be used within the recommended conditions. All voltages are absolute referenced to COM. The V_S offset is tested with all supplies biased at 15V differential

Symbol	Definition	Min	Typ	Max	Units
$V_{B1,2,3}$	High side floating supply voltage	V_S+12	V_S+15	V_S+20	V
$V_{S1,2,3}$	High side floating supply offset voltage	Note 4	---	400	
V_{CC}	Low side and logic fixed supply voltage	12	15	20	V
$V_{T/ITRIP}$	T/I_{TRIP} input voltage	V_{SS}	---	$V_{SS}+5$	
V_{IN}	Logic input voltage LIN, HIN	V_{SS}	---	$V_{SS}+5$	V
HIN	High side PWM pulse width	1	---	---	μs
Deadtime	External dead time between HIN and LIN	2	---	---	μs

Note 3: For more details, see IR21363 data sheet

Note 4: Logic operational for V_S from COM-5V to COM+600V. Logic state held for V_S from COM-5V to COM- V_{BS} . (please refer to DT97-3 for more details)

Static Electrical Characteristics Driver Function

V_{BIAS} (V_{CC} , $V_{BS1,2,3}$)=15V, unless otherwise specified. The V_{IN} and I_{IN} parameters are referenced to COM/ I_{TRIP} and are applicable to all six channels. (Note 3)

Symbol	Definition	Min	Typ	Max	Units
V_{IH}	Logic "0" input voltage	3.0	---	---	V
V_{IL}	Logic "1" input voltage	---	---	0.8	V
V_{CCUV+} , V_{BSUV+}	V_{CC} and V_{BS} supply undervoltage positive going threshold	10.6	11.1	11.6	V
V_{CCUV-} , V_{BSUV-}	V_{CC} and V_{BS} supply undervoltage negative going threshold	10.4	10.9	11.4	V
V_{CCUVH} , V_{BSUVH}	V_{CC} and V_{BS} supply undervoltage lock-out hysteresis	---	0.2	---	V
$V_{IN,Clamp}$	Input Clamp Voltage (HIN , LIN , T/I_{TRIP}) $I_{IN}=10\mu A$	4.9	5.2	5.5	V
I_{QBS}	Quiescent V_{BS} supply current $V_{IN}=0V$	---	---	165	μA
I_{QCC}	Quiescent V_{CC} supply current $V_{IN}=0V$	---	---	3.35	mA
I_{LK}	Offset Supply Leakage Current	---	---	60	μA
I_{IN+}	Input bias current $V_{IN}=5V$	---	200	300	μA
I_{IN-}	Input bias current $V_{IN}=0V$	---	100	220	μA
I_{TRIP+}	I_{TRIP} bias current $V_{ITRIP}=5V$	---	30	100	μA
I_{TRIP-}	I_{TRIP} bias current $V_{ITRIP}=0V$	---	0	1	μA
$V(I_{TRIP})$	I_{TRIP} threshold Voltage	440	490	540	mV
$V(I_{TRIP},HYS)$	I_{TRIP} Input Hysteresis	---	70	---	mV

Dynamic Electrical Characteristics

Driver only timing unless otherwise specified.)

Symbol	Parameter	Min	Typ	Max	Units	Conditions
T_{ON}	Input to Output propagation turn-on delay time (see fig.11)	---	600	---	ns	$V_{CC}=V_{BS}= 15V$, $I_C=15A$, $V^+=400V$
T_{OFF}	Input to Output propagation turn-off delay time (see fig. 11)	---	700	---	ns	
T_{FLIN}	Input Filter time (HIN , LIN)	100	200	---	ns	$V_{IN}=0$ & $V_{IN}=5V$
$T_{BLT-Trip}$	I_{TRIP} Blanking Time	100	150	---	ns	$V_{IN}=0$ & $V_{IN}=5V$
D_T	Dead Time ($V_{BS}=V_{DD}=15V$)	220	290	360	ns	$V_{BS}=V_{CC}=15V$
M_T	Matching Propagation Delay Time (On & Off)	---	40	75	ns	$V_{CC}= V_{BS}= 15V$, external dead time> 400ns
T_{ITrip}	I_{Trip} to six switch to turn-off propagation delay (see fig. 2)	---	---	3.75	μs	$V_{CC}=V_{BS}= 15V$, $I_C=15A$, $V^+=400V$
$T_{FLT-CLR}$	Post I_{Trip} to six switch to turn-off clear time (see fig. 2)	---	34	---	ms	$T_C = 25^\circ C$
		---	29	---		$T_C = 100^\circ C$

Thermal and Mechanical Characteristics

Symbol	Parameter	Min	Typ	Max	Units	Conditions
$R_{th(J-C)}$	Thermal resistance, per IGBT	---	1.5	1.7	°C/W	Flat, greased surface. Heatsink compound thermal conductivity 1W/mK
$R_{th(J-C)}$	Thermal resistance, per Diode	---	2.5	---		
$R_{th(C-S)}$	Thermal resistance, C-S	---	0.1	---		
C_D	Creepage Distance	3.5	---	---	mm	See outline Drawings

Internal Current Sensing Resistor - Shunt Characteristics

Symbol	Parameter	Min	Typ	Max	Units	Conditions
R_{Shunt}	Resistance	9.4	9.6	9.8	mΩ	$T_C = 25^\circ\text{C}$
T_{Coeff}	Temperature Coefficient	0	---	200	ppm/°C	
P_{Shunt}	Power Dissipation	---	---	4.5	W	$-40^\circ\text{C} < T_C < 100^\circ\text{C}$
T_{Range}	Temperature Range	-20	---	125	°C	

Internal NTC - Thermistor Characteristics

Parameter	Definition	Min	Typ	Max	Units	Conditions
R_{25}	Resistance	97	100	103	kΩ	$T_C = 25^\circ\text{C}$
R_{125}	Resistance	2.25	2.52	2.8	kΩ	$T_C = 125^\circ\text{C}$
B	B-constant (25-50°C)	4165	4250	4335	k	$R_2 = R_1 e^{[B(1/T_2 - 1/T_1)]}$
Temperature Range		-40	---	125	°C	
Typ. Dissipation constant		---	1	---	mW/°C	$T_C = 25^\circ\text{C}$

Input-Output Logic Level Table

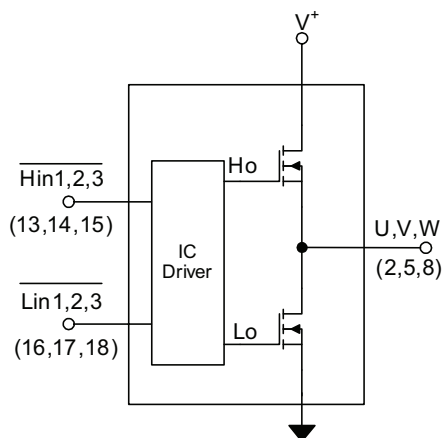

I_{TRIP}	$\overline{HIN1,2,3}$	$\overline{LIN1,2,3}$	U,V,W
0	0	1	V^+
0	1	0	0
0	1	1	X
1	X	X	X

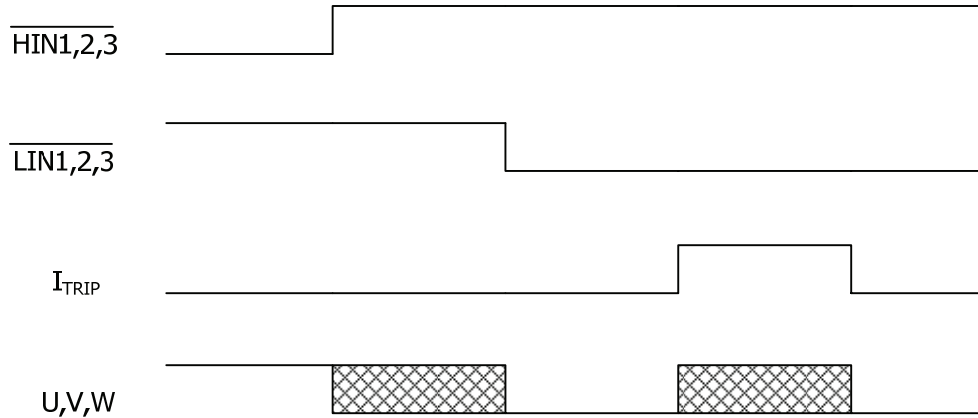

Figure 1. Input/Output Timing Diagram

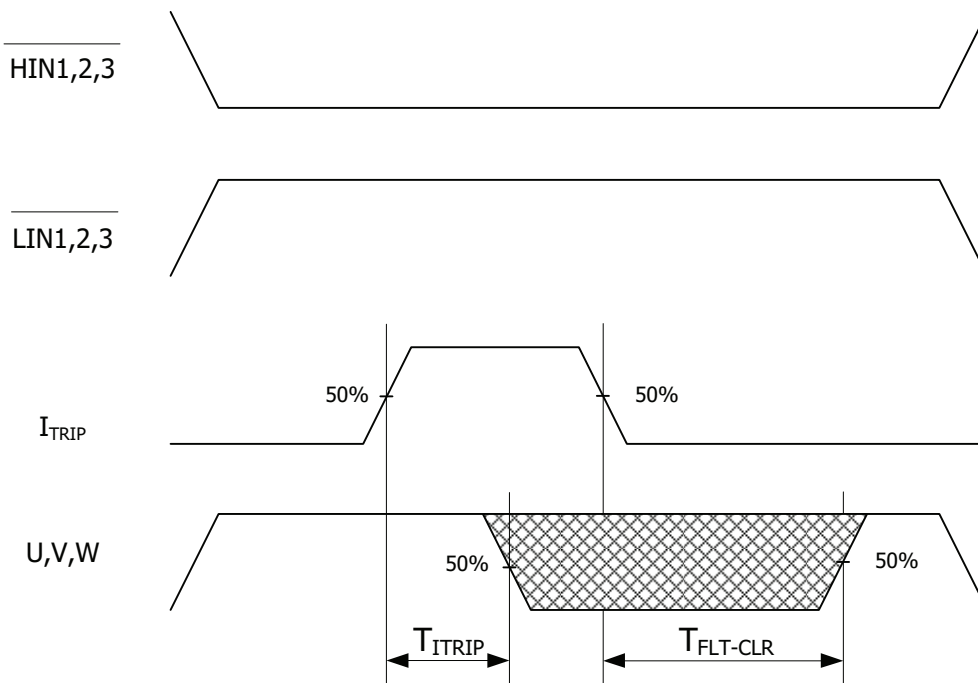

Figure 2. I_{TRIP} Timing Waveform

Note 7: The shaded area indicates that both high-side and low-side switches are off and therefore the half-bridge output voltage would be determined by the direction of current flow in the load.

IRAM136-3063B

Module Pin-Out Description

Pin	Name	Description
1	V_{B1}	High Side Floating Supply Voltage 1
2	U, V_{S1}	Output 1 - High Side Floating Supply Offset Voltage
3	NA	none
4	V_{B2}	High Side Floating Supply voltage 2
5	V, V_{S2}	Output 2 - High Side Floating Supply Offset Voltage
6	NA	none
7	V_{B3}	High Side Floating Supply voltage 3
8	W, V_{S3}	Output 3 - High Side Floating Supply Offset Voltage
9	NA	none
10	V^+	Positive Bus Input Voltage
11	NA	none
12	V^-	Negative Bus Input Voltage
13	\overline{H}_{IN1}	Logic Input High Side Gate Driver - Phase 1
14	\overline{H}_{IN2}	Logic Input High Side Gate Driver - Phase 2
15	\overline{H}_{IN3}	Logic Input High Side Gate Driver - Phase 3
16	\overline{L}_{IN1}	Logic Input Low Side Gate Driver - Phase 1
17	\overline{L}_{IN2}	Logic Input Low Side Gate Driver - Phase 2
18	\overline{L}_{IN3}	Logic Input Low Side Gate Driver - Phase 3
19	$\overline{\text{Fault}}/T_{\text{MON}}$	Temperature Monitor and Fault Function
20	I_{Sense}	Current Monitor
21	V_{CC}	+15V Main Supply
22	V_{SS}	Negative Main Supply

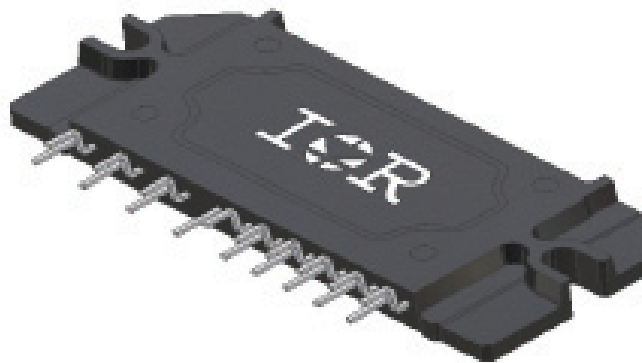

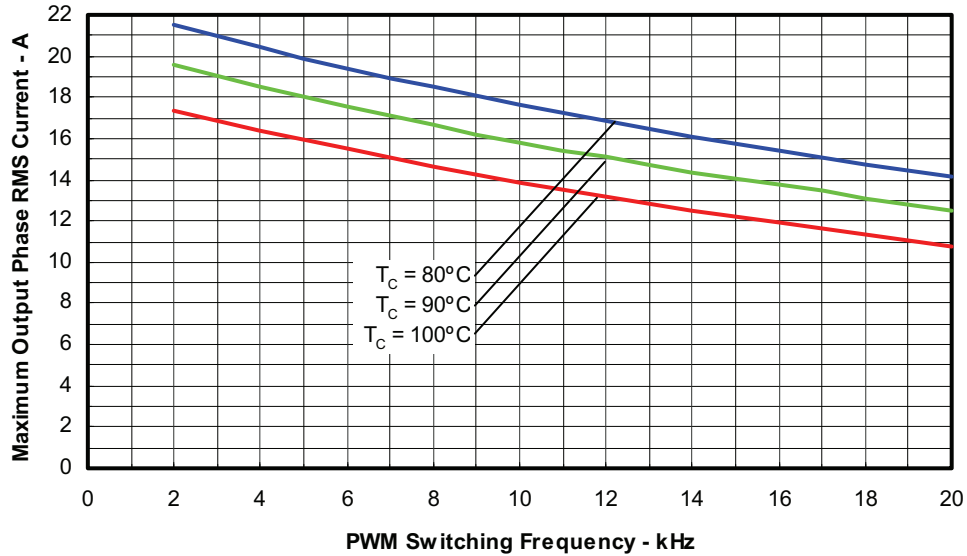

Figure 3. Maximum Sinusoidal Phase Current vs. PWM Switching Frequency
Sinusoidal Modulation, $V^+ = 400\text{V}$, $T_j = 150^\circ\text{C}$, Modulation Depth=0.8, PF=0.6

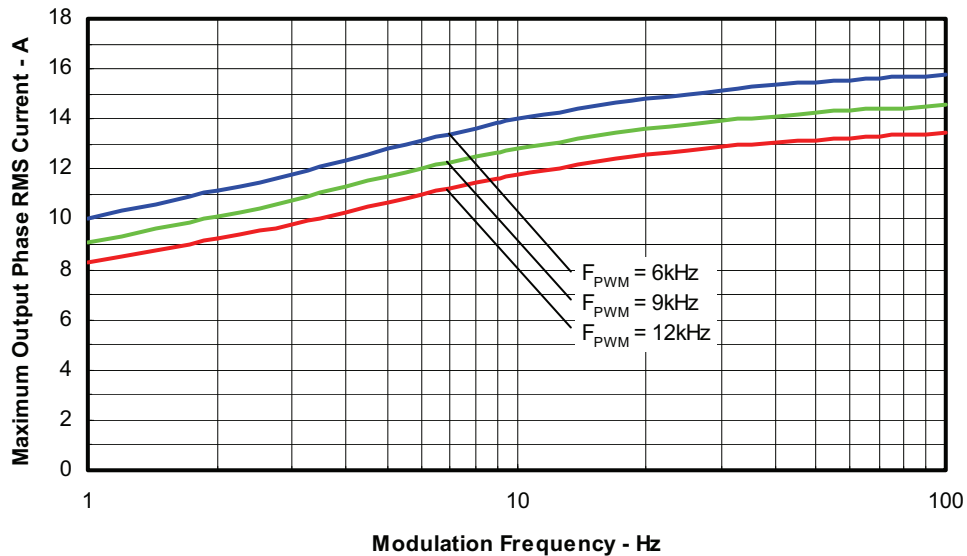

Figure 4. Maximum Sinusoidal Phase Current vs. Modulation Frequency
Sinusoidal Modulation, $V^+ = 400\text{V}$, $T_j = 100^\circ\text{C}$, Modulation Depth=0.8, PF=0.6

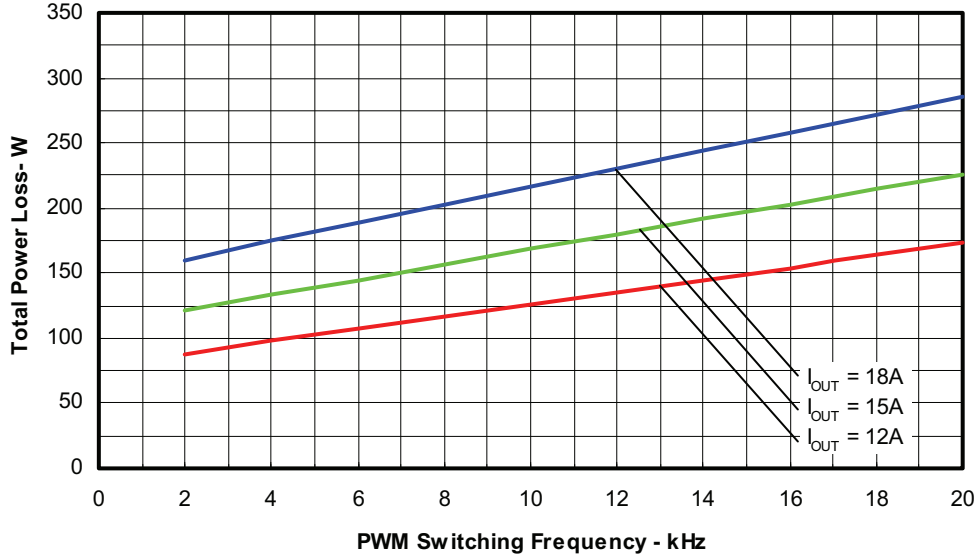

Figure 5. Total Power Losses vs. PWM Switching Frequency
Sinusoidal Modulation, $V^+ = 400V$, $T_J = 150^\circ C$, Modulation Depth=0.8, PF=0.6

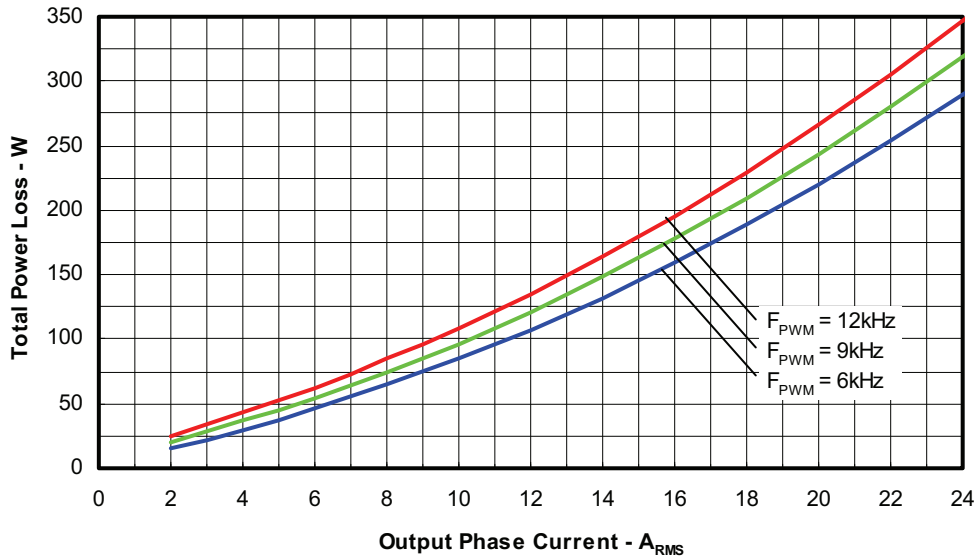

Figure 6. Total Power Losses vs. Output Phase Current
Sinusoidal Modulation, $V^+ = 400V$, $T_J = 150^\circ C$, Modulation Depth=0.8, PF=0.6

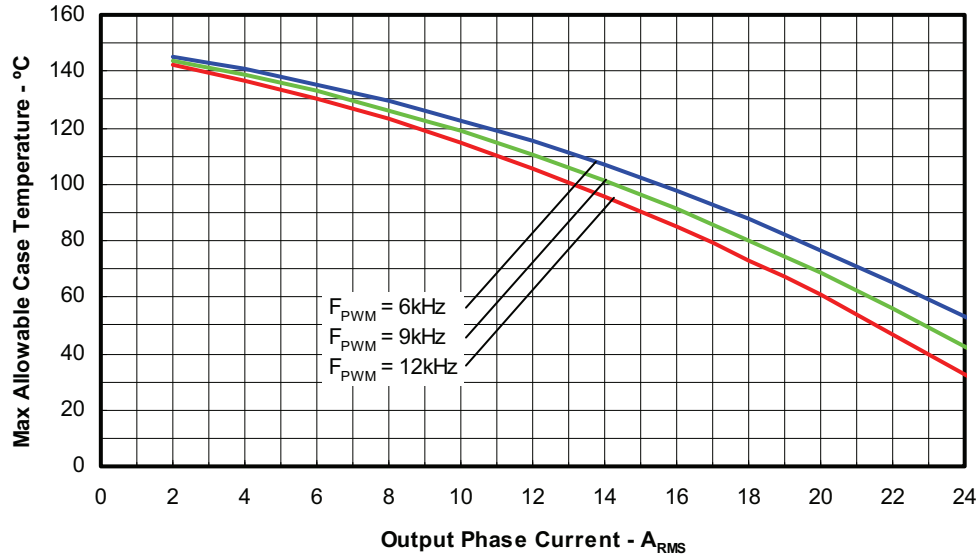

Figure 7. Maximum Allowable Case Temperature vs. Output RMS Current per Phase
Sinusoidal Modulation, $V^+ = 400V$, $T_j = 150^\circ C$, Modulation Depth=0.8, PF=0.6

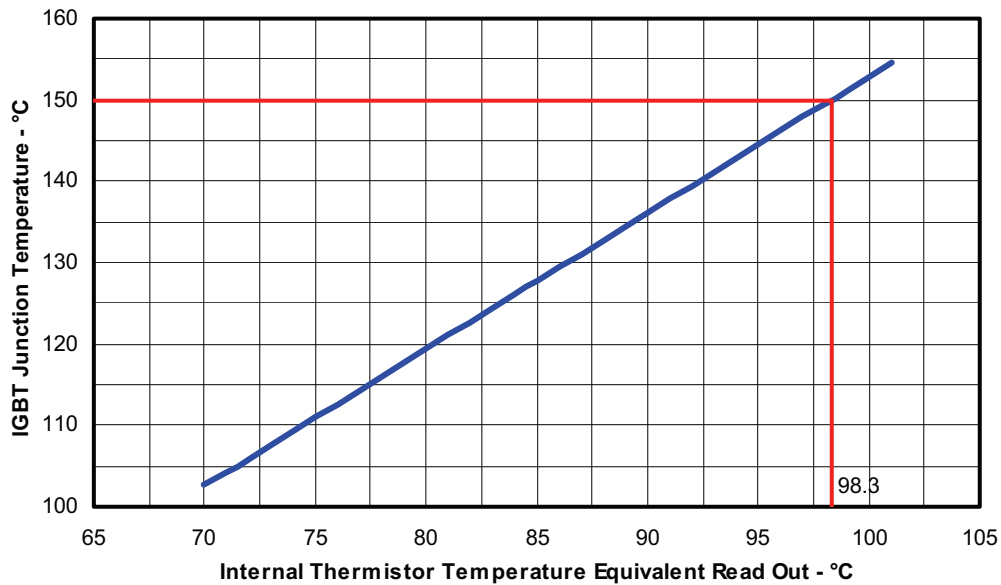

Figure 8. Estimated Maximum MOSFET Junction Temperature vs. Thermistor Temperature
Sinusoidal Modulation, $V^+ = 400V$, $I_{phase} = 15A_{RMS}$, $f_{sw} = 6kHz$, $f_{mod} = 50Hz$, $MI = 0.8$, $PF = 0.6$

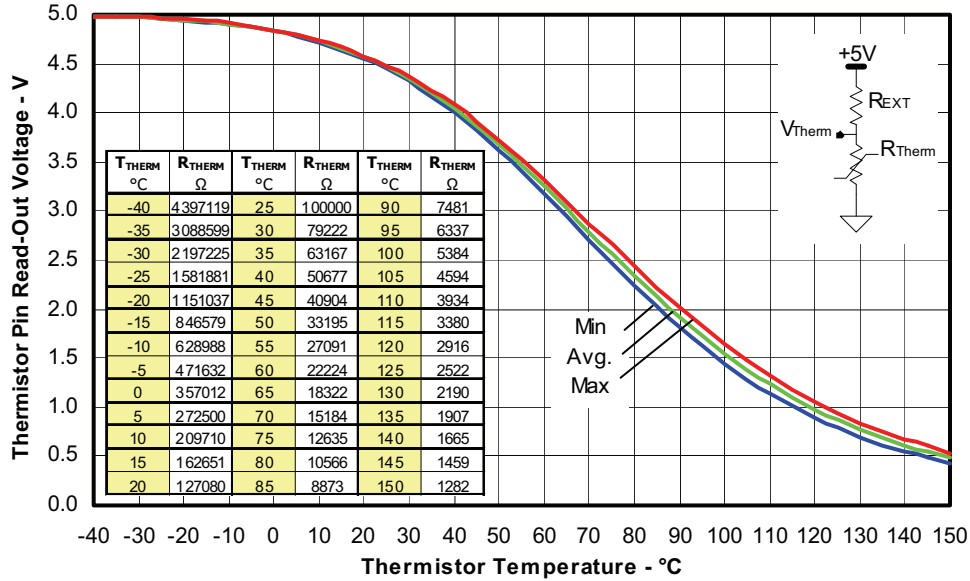

Figure 9. Thermistor Readout vs. Temperature (12Kohm pull-up resistor, 5V) and Normal Thermistor Resistance values vs. Temperature Table.

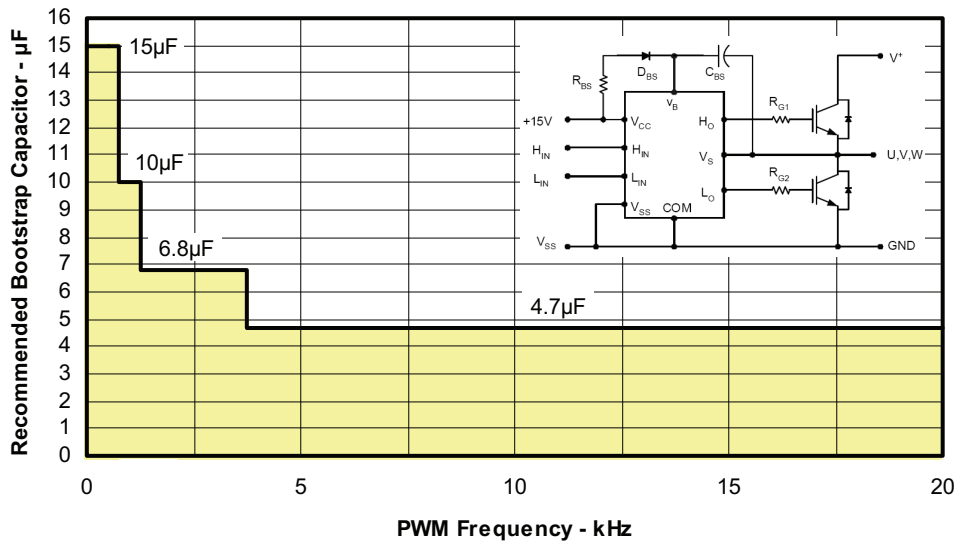

Figure 10. Recommended Bootstrap Capacitor Value vs. Switching Frequency

Figure 11. Switching Parameter Definitions

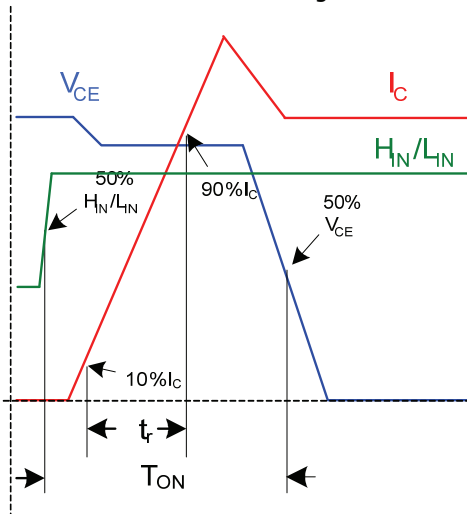

Figure 11a. Input to Output propagation turn-on delay time.

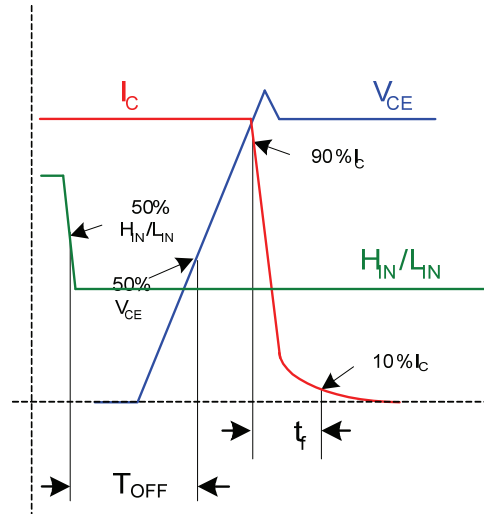

Figure 11b. Input to Output propagation turn-off delay time.

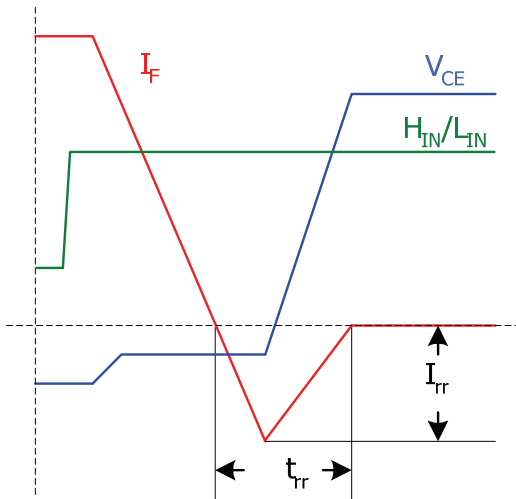

Figure 11c. Diode Reverse Recovery.

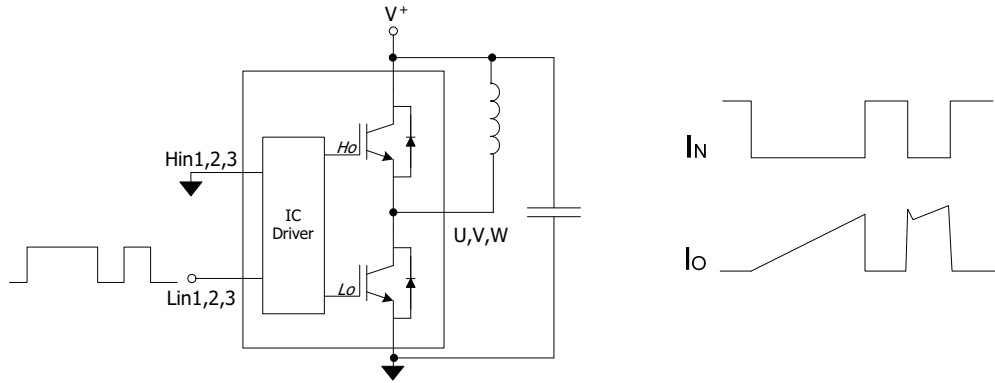

Figure CT1. Switching Loss Circuit

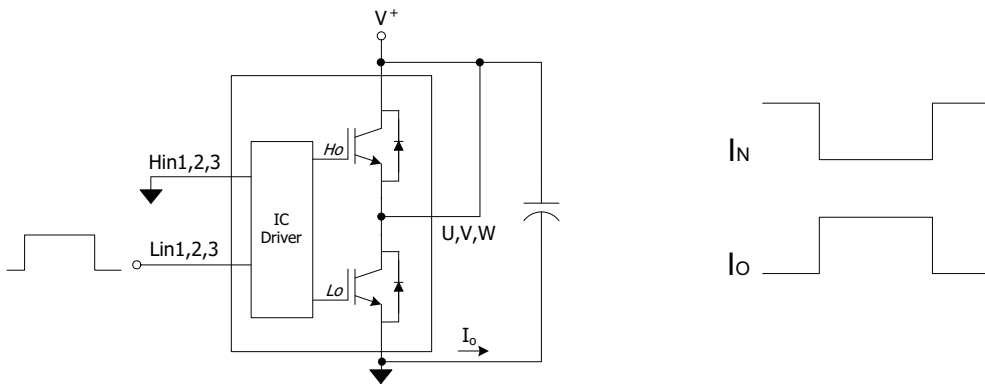

Figure CT2. S.C.SOA Circuit

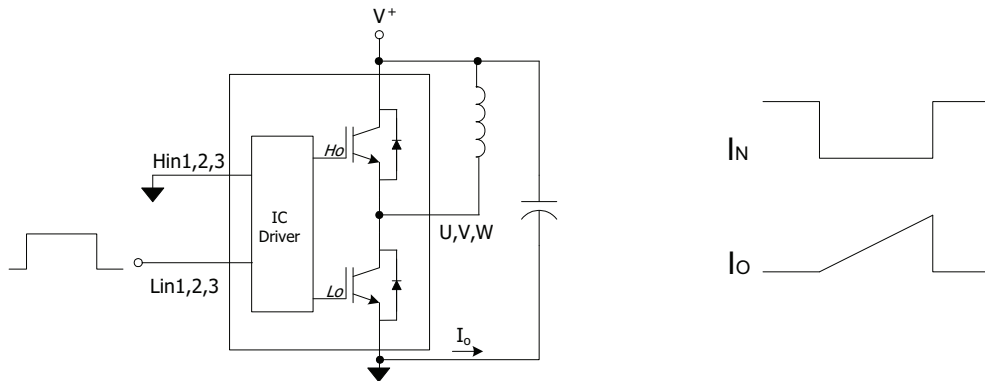
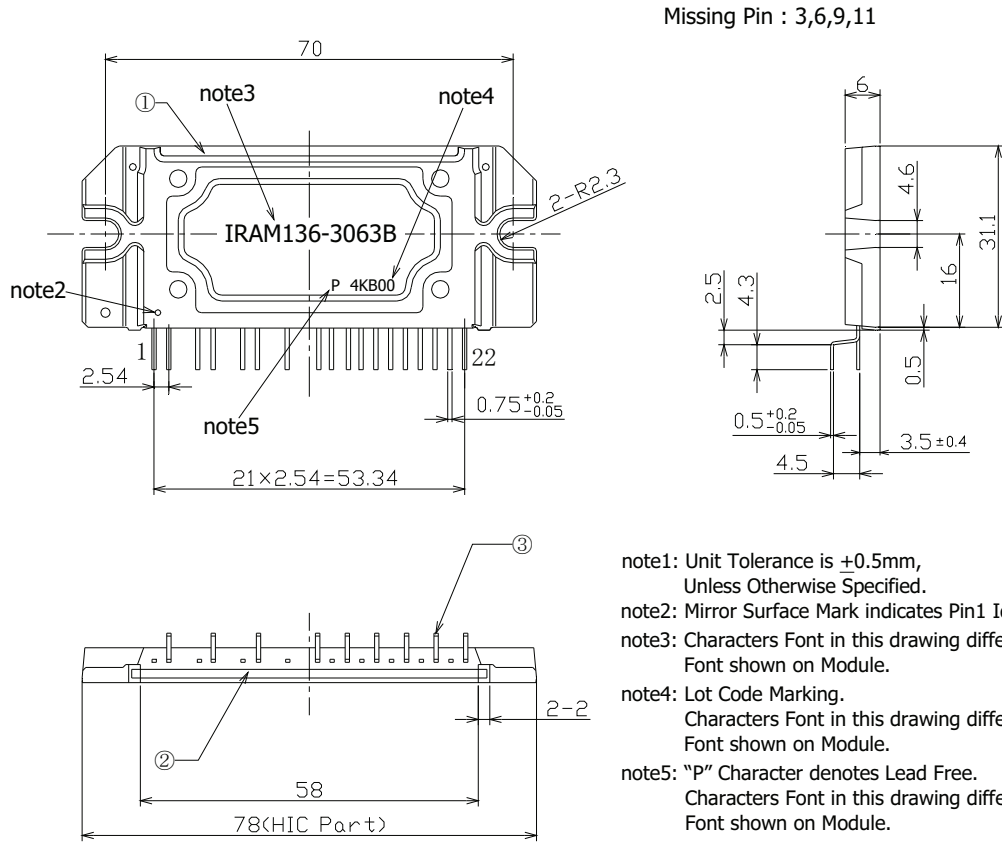

Figure CT3. R.B.SOA Circuit

IRAM136-3063B

Package Outline IRAM136-3063B



Dimensions in mm
 For mounting instruction see AN-1049

Looking for pricing, stock, or lifecycle information?

Click below to explore more details on WIN SOURCE:

 [View IRAM136-3063B2 on WIN SOURCE](#)

 [Infineon Technologies](#) Information

Optimize Your Supply Chain with WIN SOURCE Solutions

-  Global Sourcing Solution
-  Obsolete Management
-  Cost Control Management
-  Shortage Management
-  Alternative Solution
-  Excess Inventory Management