



## FEATURES

- Single 5V to 21V application
- Wide Input Voltage Range from 1V to 21V with external Vcc
- Output Voltage Range: 0.5V to 0.86\*PVin
- Dual output, 4A/Phase
- Enhanced Line/Load Regulation with Feed-Forward
- Programmable Switching Frequency up to 1.5MHz
- Internal Digital Soft-Start
- Enable input with Voltage Monitoring Capability
- Thermally compensated current limit and Hiccup Mode Over Current Protection
- External synchronization with Smooth Clocking
- Precision Reference Voltage (0.5V +/-1%)
- Seq pin for Sequencing Applications
- Integrated MOSFETs, drivers and Bootstrap diode
- Thermal Shut Down
- Open Feedback Line Protection
- Over Voltage Protection
- Interleaved Phases to reduce Input Capacitors
- Monotonic Start-Up
- Operating Junction Temp: -40°C<Tj<125°C
- Small Size 5mm x 6mm PQFN
- Lead-free, Halogen-free, and RoHS Compliant

## DESCRIPTION

The IR3891 Sup/IRBuck® is an easy-to-use, fully integrated and highly efficient DC/DC regulator. The onboard PWM controller and MOSFETs make IR3891 a space-efficient solution, providing accurate power delivery for low output voltage.

IR3891 is a versatile regulator which offers programmability of switching frequency and a fixed current limit while operating in wide input and output voltage range.

The switching frequency is programmable from 300kHz to 1.5MHz for an optimum solution.

It also features important protection functions, such as Over Voltage Protection (OVP), Pre-Bias startup, hiccup current limit and thermal shutdown to give required system level security in the event of fault conditions.

## APPLICATIONS

- Server Applications
- Netcom Applications
- Set Top Box Applications
- Storage Applications
- Embedded telecom Systems
- Distributed Point of Load Power Architectures
- Computing Peripheral Voltage regulators
- General DC-DC Converters

## ORDERING INFORMATION

Base Part Number	Package Type	Standard Pack		Orderable Part Number
		Form	Quantity	
IR3891	PQFN 5mm x 6mm	Tape and Reel	4000	IR3891MTRPBF

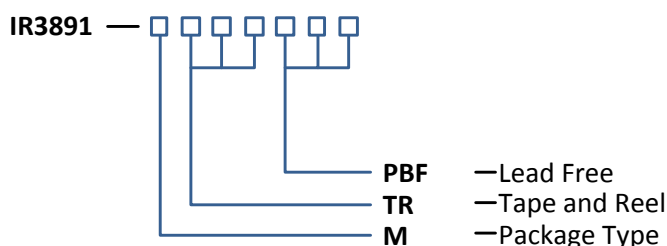

## BASIC APPLICATION

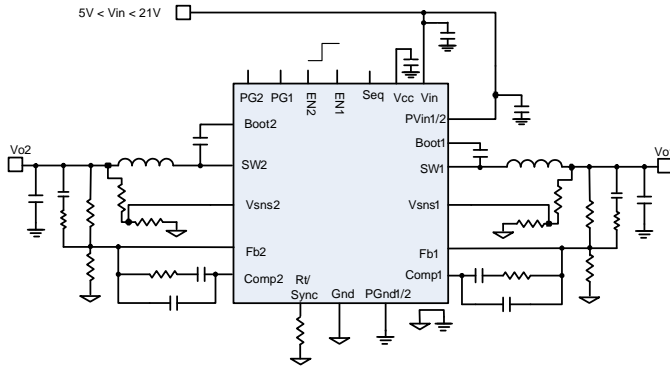

Figure 1: IR3891 Basic Application Circuit

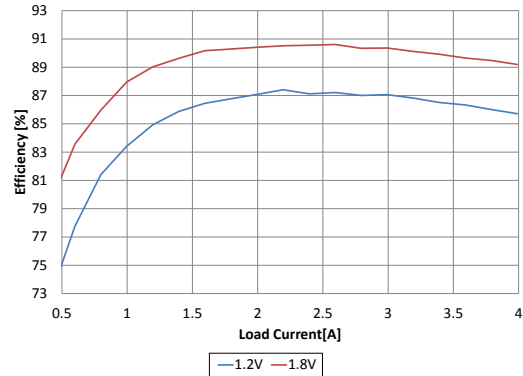
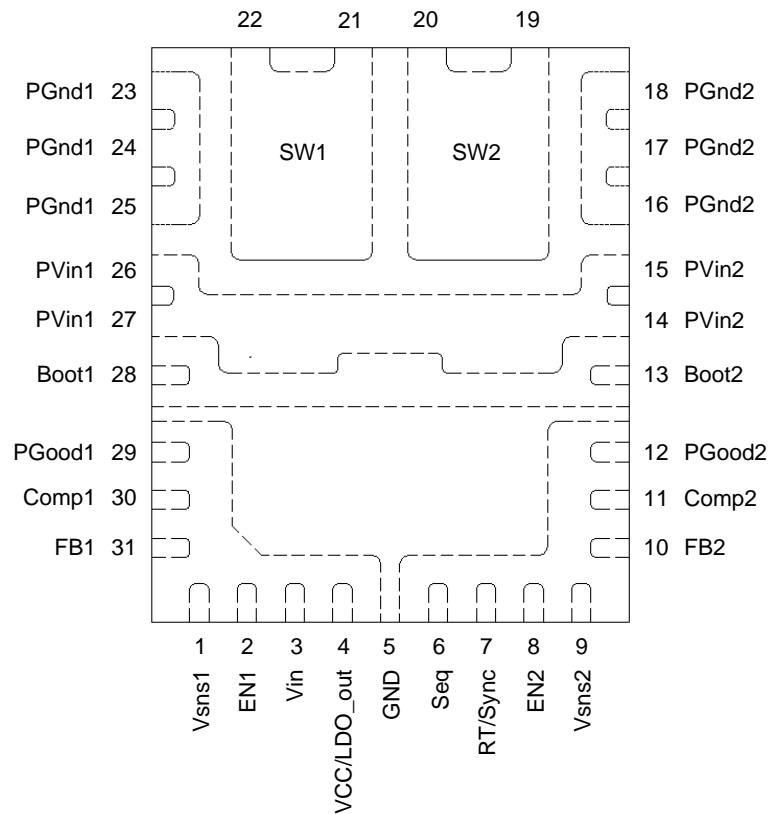
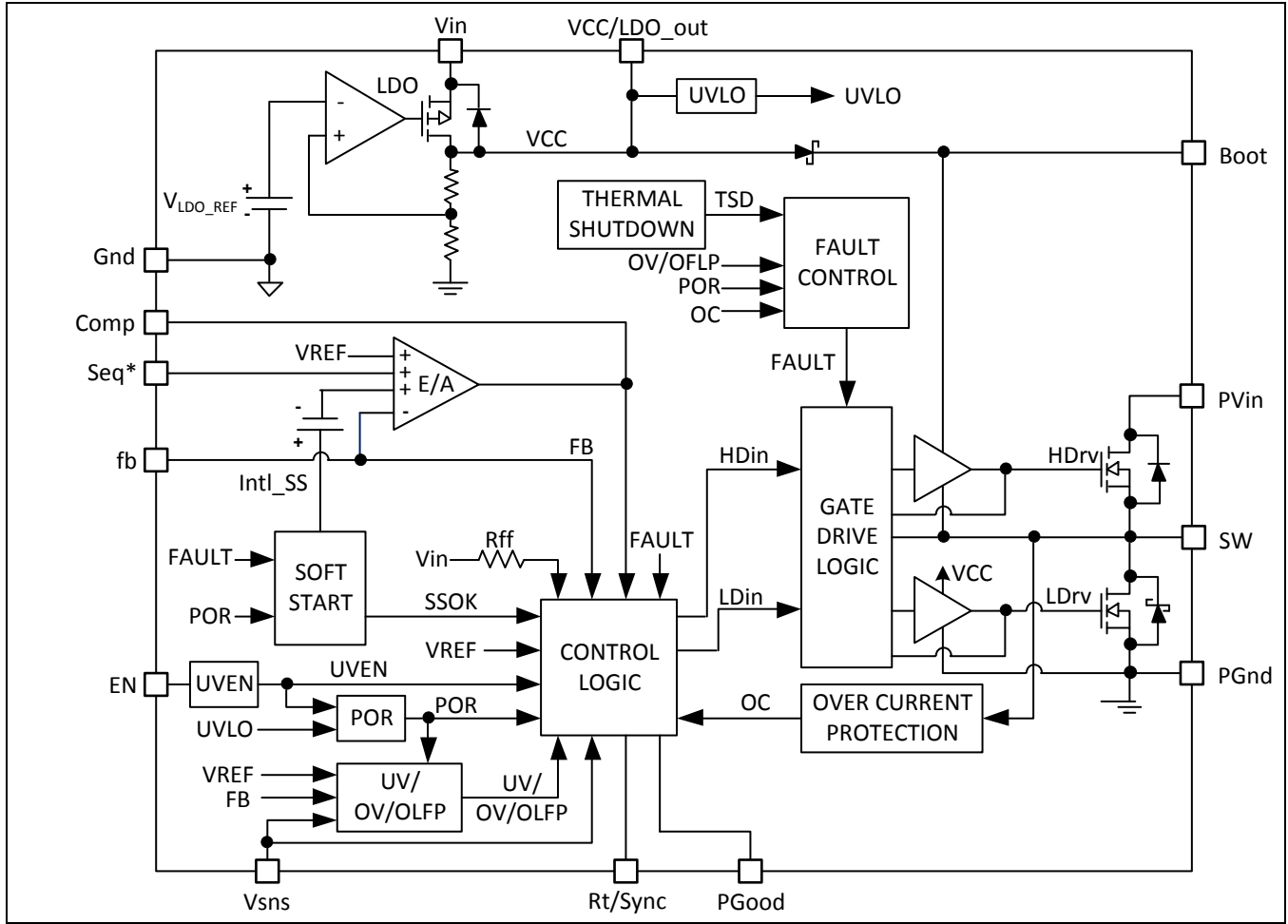

Figure 2: Efficiency [Vin=12V, Fsw=600kHz]

## PIN DIAGRAM

5mm X 6mm POWER QFN  
Top View



**FUNCTIONAL BLOCK DIAGRAM**

\*The Seq pin is only available for channel 2

Figure 3: IR3891 Simplified Block Diagram (one phase)

## PIN DESCRIPTIONS

PIN #	PIN NAME	PIN DESCRIPTION
1, 9	Vsns 1/2	Sense pins for over-voltage protection and PGood. A resistor divider with the same ratio as the respective feedback resistor divider should be connected between each Vsns pin and its respective Vout.
2, 8	EN 1/2	Enable pins for turning on and off the regulator.
3	Vin	Input voltage for Internal LDO. A 1.0 $\mu$ F capacitor should be connected between this pin and PGnd. If external supply is connected to VCC pin, this pin should be shorted to VCC pin.
4	VCC/LDO_out	Input Bias Voltage, output of the internal LDO. Place a minimum 2.2 $\mu$ F cap from this pin to PGnd.
5	GND	Signal ground for internal reference and control circuitry.
6	Seq	Input to error amplifier for sequencing purposes. Can be left floating for non-sequencing applications. It is only connected to the Error-Amplifier of channel 2.
7	Rt/Sync	Multi-function pin to set switching frequency. Use an external resistor from this pin to Gnd to set the free-running switching frequency. Or use an external clock signal to connect to this pin through a diode, the device's switching frequency is synchronized with the external clock.
10, 31	FB 2/1	Inverting inputs to the error amplifiers. These pins are connected directly to the outputs of the regulator via resistor dividers to set the output voltages and provide feedback to the error amplifiers.
11, 30	Comp 2/1	Output of the error amplifiers. External resistor and capacitor networks are typically connected from these pins to its respective Fb pin to provide loop compensation.
12, 29	PGood 2/1	Power Good status pins are open drain outputs. The pins are typically connected to VCC via pull up resistors.
13, 28	Boot 2/1	Supply voltages for high side drivers, 100nF capacitors should be connected between these pins and their respective SW pin.
14, 15, 26, 27	PVin 2/1	Input voltage for power stage.
16, 17, 18, 23, 24, 25	PGnd 2/1	Power Ground. These pins serve as a separated ground for the MOSFET drivers and should be connected to the system's power ground plane.
19, 20, 21, 22	SW 2/1	Switch nodes. These pins are connected to the output inductors.

## ABSOLUTE MAXIMUM RATINGS

Stresses beyond those listed under “Absolute Maximum Ratings” may cause permanent damage to the device. These are stress ratings only and functional operation of the device at these or any other conditions beyond those indicated in the operational sections of the specifications are not implied.

PVin	-0.3V to 25V	
Vin	-0.3V to 25V	
VCC	-0.3V to 8V (Note 1)	
SW	-0.3V to 25V (DC), -4V to 25V (AC, 100ns)	
BOOT	-0.3V to 33V	
BOOT to SW	-0.3V to VCC + 0.3V (Note 2)	
EN, PGood	-0.3V to VCC + 0.3V (Note 2)	
Other Input/Output pins	-0.3V to 3.9V	
PGnd to GND	-0.3V to + 0.3V	
Junction Temperature Range	-40°C to 150°C	
Storage Temperature Range	-55°C to 150°C	
ESD	Machine Model	Class A
	Human Body Model	Class 1C
	Charged Device Model	Class III
Moisture Sensitivity level	JEDEC Level 2 @ 260°C	
RoHS Compliant	Yes	

**Note:**

- VCC must not exceed 7.5V for Junction Temperature between -10°C and -40°C.
- Must not exceed 8V.

### THERMAL INFORMATION

Thermal Resistance, Junction to Case Top ( $\theta_{JC\_TOP}$ )	36 °C/W
Thermal Resistance, Junction to PCB ( $\theta_{JB}$ )	3.6 °C/W
Thermal Resistance, Junction to Ambient ( $\theta_{JA}$ ) (Note 3)	24.7 °C/W

**Note:**

- Thermal resistance ( $\theta_{JA}$ ) is measured with components mounted on a high effective thermal conductivity test board in free air.

## ELECTRICAL SPECIFICATIONS

### RECOMMENDED OPERATING CONDITIONS

SYMBOL	DEFINITION	MIN	MAX	UNIT
PVin	Input Bus Voltage *	1.0	21	V
Vin	Supply Voltage	5.0	21	
VCC	Supply Voltage **	4.5	7.5	
Boot to SW	Supply Voltage	4.5	7.5	
V <sub>O</sub>	Output Voltage	0.5	0.86 * PVin	
I <sub>o</sub>	Output Current	0	4	A / Phase
Fs	Switching Frequency	300	1500	kHz
T <sub>J</sub>	Junction Temperature	-40	125	°C

\* SW1/2 node must not exceed 25V

\*\* When VCC is connected to an externally regulated supply, also connect Vin.

### ELECTRICAL CHARACTERISTICS

Unless otherwise specified, these specifications apply over, 6.8V < Vin=PVin < 21V in 0°C < T<sub>J</sub> < 125°C. Typical values are specified at T<sub>a</sub> = 25°C.

PARAMETER	SYMBOL	CONDITIONS	MIN	TYP	MAX	UNIT
<b>Power Stage</b>						
Power Losses	P <sub>LOSS</sub>	Vin = 12V, Vout <sub>1</sub> = 1.8V, Vout <sub>2</sub> = 1.2V, I <sub>o</sub> = 4A/phase, Fs = 600kHz, L1 = 2.2uH, L2 = 1.5uH, Note 4		1.38		W
Top Switch	R <sub>ds(on)_Top</sub>	V <sub>Boot</sub> - V <sub>sw</sub> = 5.3V, I <sub>o</sub> = 4A, T <sub>J</sub> = 25°C		27.5	36.4	mΩ
Bottom Switch	R <sub>ds(on)_Bot</sub>	V <sub>cc</sub> = 5.3V, I <sub>o</sub> = 4A, T <sub>J</sub> = 25°C		19.5	24.2	
Bootstrap Diode Forward Voltage		I(Boot) = 10mA		300	450	mV
SW Leakage Current	I <sub>SW</sub>	SW = 0V, Enable = 0V			1	μA
		SW = 0V, Enable = high, V <sub>Seq</sub> = 0V			2	μA
Dead Band Time	T <sub>db</sub>	Note 4	10	20	30	ns
<b>Supply Current</b>						
VIN Supply Current (standby)	I <sub>in(Standby)</sub>	EN = Low, No Switching		100	175	μA
VIN Supply Current (dynamic)	I <sub>in(Dyn)</sub>	EN = High, Fs = 600kHz,		12.0	17	mA
<b>VCC LDO Output</b>						
Output Voltage	V <sub>cc</sub>	Vin(min) = 6.8V, I <sub>o</sub> = 0-60mA, C <sub>load</sub> = 2.2uF	5	5.3	5.6	V
VCC Dropout	V <sub>cc_drop</sub>	I <sub>cc</sub> = 60mA, C <sub>load</sub> = 2.2uF			0.75	V

PARAMETER	SYMBOL	CONDITIONS	MIN	TYP	MAX	UNIT
Short Circuit Current	Ishort			120		mA
<b>Oscillator</b>						
Rt Voltage	Vrt			1.0		V
Frequency Range	Fs	Rt = 80.6K	270	300	330	kHz
		Rt = 39.2K	540	600	660	
		Rt = 15K	1350	1500	1650	
Ramp Amplitude	Vramp	Vin = 6.8V, Vin slew rate max = 1V/μs, Note 4		1.02		Vp-p
		Vin = 12V, Vin slew rate max = 1V/μs, Note 4		1.80		
		Vin = 21V, Vin slew rate max = 1V/μs, Note 4		3.15		
		Vcc=Vin = 5V, For external Vcc operation, Note 4		0.75		
Min Pulse Width	Tmin(ctrl)	Note 4			60	ns
Max Duty Cycle	Dmax	Fs = 300kHz, Vin=Pvin=12V	86			%
Fixed Off Time	Toff	Note 4		200	250	ns
Sync Frequency Range	Fsync		270		1650	kHz
Sync Pulse Duration	Tsync		100	200		ns
Sync Level Threshold	High		3			V
	Low				0.6	
<b>Error Amplifier</b>						
Seq Input Offset Voltage	Vos_VSeq	VSeq – Vfb; VSeq=250mV	-3		+3	%
Input Bias Current	IFb(E/A)		-200		+200	nA
Seq Input impedance	Rin_Seq(E/A)	Internal Seq pull-up resistor		300		kΩ
Sink Current	Isink(E/A)		0.4	0.85	1.2	mA
Source Current	Isource(E/A)		3	4	7	mA
Slew Rate	SR	Note 4	7	12	20	V/μs
Gain-Bandwidth Product	GBWP	Note 4	20	30	40	MHz
DC Gain	Gain	Note 4	80	90	110	dB
Maximum Voltage	Vmax(E/A)		1.7	2	2.3	V
Minimum Voltage	Vmin(E/A)			120	220	mV
Vseq Common Mode Voltage			0		0.77	V

PARAMETER	SYMBOL	CONDITIONS	MIN	TYP	MAX	UNIT
<b>Reference Voltage</b>						
Feedback Voltage	Vfb	VSeq=3.3V		0.5		V
Accuracy		0°C < Tj < 85°C	-1		+1	%
		-40°C < Tj < 125°C, Note 5	-1.5		+1.5	
<b>Soft Start</b>						
Soft Start Ramp Rate	Ramp (SS_start)		0.14	0.18	0.22	mV / µs
<b>Fault Protection</b>						
Current Limit	I <sub>cc</sub>	V <sub>cc</sub> =5.3V, Tj = 25°C	4.8	6.0	7.2	A / Phase
Hiccup blanking time	T <sub>blk_Hiccup</sub>	Note 4		20.48		ms
OFLP Trip Threshold	OFLP(threshold)	Fb Falling	65	70	75	%Vref
OFLP Fault Prop Delay	OFLP(delay)		0.1	0.3	0.5	µs
OVP Trip Threshold	OVP(threshold)	V <sub>sns</sub> Rising	115	120	125	%Vref
OVP Trip Threshold Hysteresis	OVP_Hys	V <sub>sns</sub> falling from above 120% of Vref, Sync_FET turns off afterwards		25		mV
OVP Comparator Delay	OVP(delay)			2		µs
Thermal Shutdown		Note 4		140		°C
Thermal Hysteresis		Note 4		20		°C
V <sub>cc</sub> -Start-Threshold	VCC_UVLO_Start	VCC Rising Trip Level	4.0	4.2	4.4	V
V <sub>cc</sub> -Stop-Threshold	VCC_UVLO_Stop	VCC Falling Trip Level	3.7	3.9	4.1	
<b>Input / Output Signals</b>						
Enable-Start-Threshold	EN_UVLO_Start	Supply ramping up	1.14	1.2	1.26	V
Enable-Stop-Threshold	EN_UVLO_Stop	Supply ramping down	0.95	1	1.05	
Enable leakage current	I <sub>en</sub>	Enable=3.3V		3	4.5	µA
Power Good upper Threshold	VPG(upper)	V <sub>sns</sub> Rising	80	85	90	%Vref
Power Good lower Threshold	VPG(lower)	V <sub>sns</sub> Falling	75	80	85	%Vref
Lower Threshold Delay	VPG(lower)_Dly	V <sub>sns</sub> Rising	1	1.3	1.6	ms
PGood Voltage Low	PG(voltage)	I <sub>Pgood</sub> = -5mA			0.5	V

**Note:**

4. Guaranteed by design but not tested in production.
5. Cold temperature performance is guaranteed via correlation using statistical quality control. Not tested in production.

## TYPICAL EFFICIENCY AND POWER LOSS CURVES

$P_{Vin} = 12V$ ,  $V_{cc} = \text{Internal LDO}$ ,  $I_o = 0-4A$ ,  $F_s = 600kHz$ , Room Temperature, No Air Flow. Note that the losses of the inductor, input and output capacitors are also considered in the efficiency and power loss curves. The table below shows the indicator used for each of the output voltages in the efficiency measurement while running a single channel and disabling the other.

VOUT (V)	LOUT ( $\mu H$ )	P/N	DCR ( $m\Omega$ )
1.0	1.5	7443340150 (Wurth Elektronik)	4.4
1.2	1.5	7443340150 (Wurth Elektronik)	4.4
1.8	2.2	7443340220 (Wurth Elektronik)	4.4
3.3	3.3	7443340330 (Wurth Elektronik)	6.5
5.0	3.3	7443340330 (Wurth Elektronik)	6.5

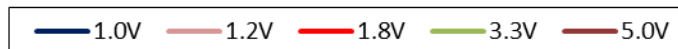
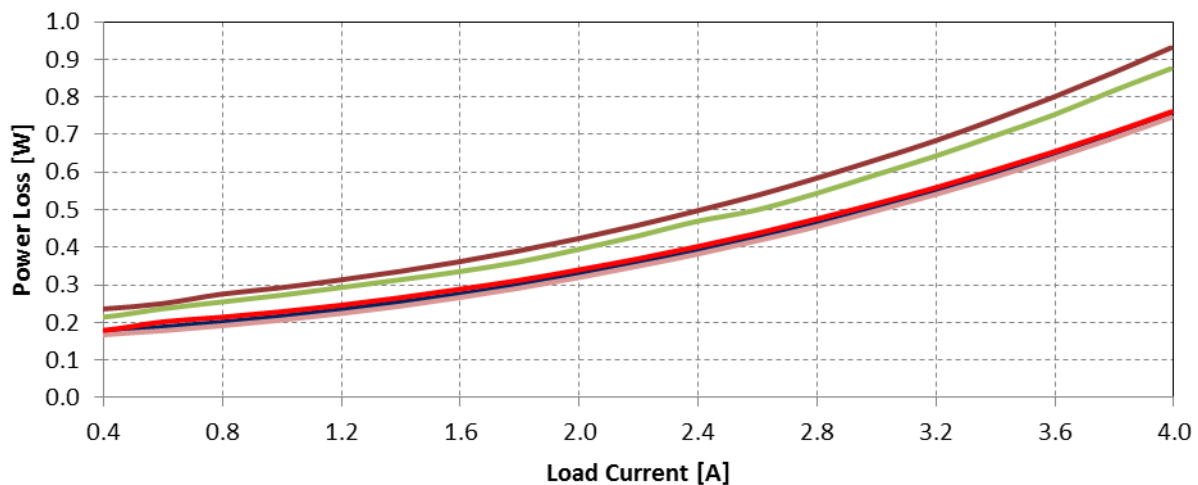
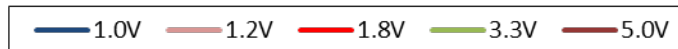
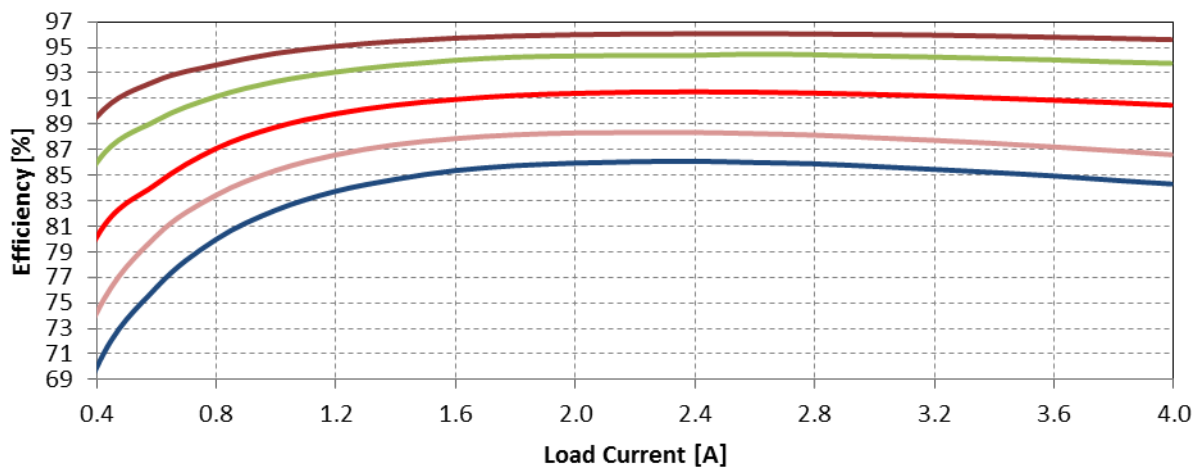

## TYPICAL EFFICIENCY AND POWER LOSS CURVES

$P_{Vin} = 12V$ ,  $V_{in} = V_{cc} = 5V$ ,  $I_o=0-4A$ ,  $F_s= 600kHz$ , Room Temperature, No Air Flow. Note that the losses of the inductor, input and output capacitors are also considered in the efficiency and power loss curves. The table below shows the indicator used for each of the output voltages in the efficiency measurement while running a single channel and disabling the other.

VOUT (V)	LOUT (uH)	P/N	DCR (mΩ)
1.0	1.5	PCMB065T-1R5MS (Cyntec)	6.7
1.2	1.5	PCMB065T-1R5MS (Cyntec)	6.7
1.8	2.2	7443340220 (Wurth Elektronik)	4.4
3.3	3.3	7443340330 (Wurth Elektronik)	6.5
5.0	3.3	7443340330 (Wurth Elektronik)	6.5

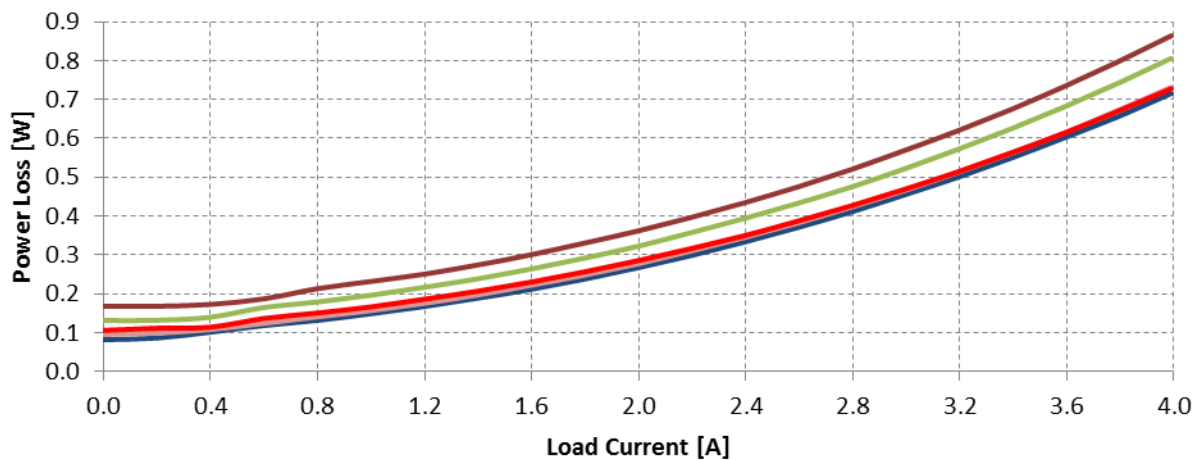
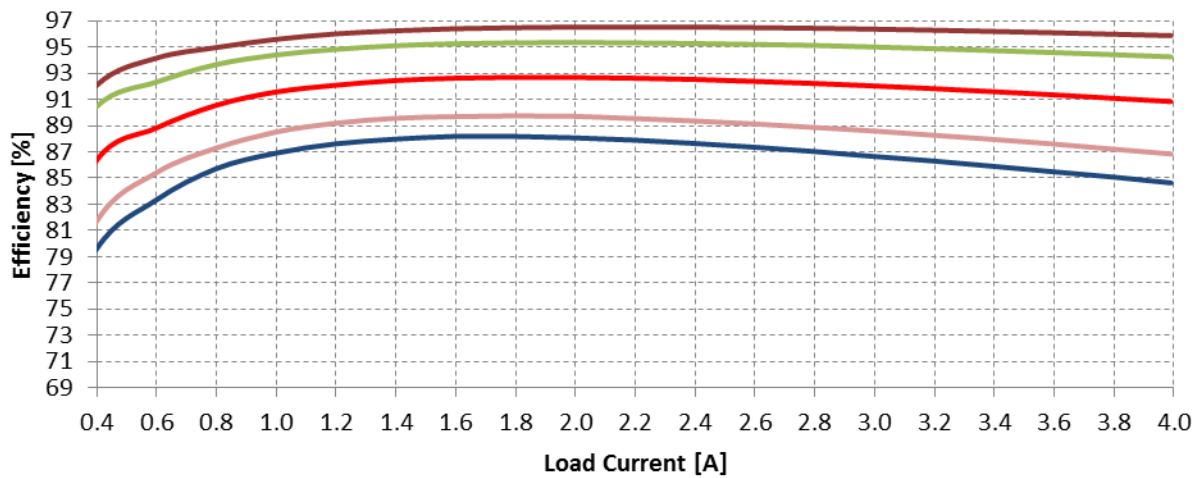

## TYPICAL EFFICIENCY AND POWER LOSS CURVES

$P_{Vin} = 5V$ ,  $V_{cc} = 5V$ ,  $I_o=0-4A$ ,  $F_s = 600kHz$ , Room Temperature, No Air Flow. Note that the losses of the inductor, input and output capacitors are also considered in the efficiency and power loss curves. The table below shows the indicator used for each of the output voltages in the efficiency measurement while running a single channel and disabling the other.

VOUT (V)	LOUT (uH)	P/N	DCR (mΩ)
1.0	1.0	PCMB065T-1R0MS (Cyntec)	5.6
1.2	1.5	PCMB065T-1R5MS (Cyntec)	6.7
1.8	1.5	PCMB065T-1R5MS (Cyntec)	6.7
3.3	1.5	PCMB065T-1R5MS (Cyntec)	6.7

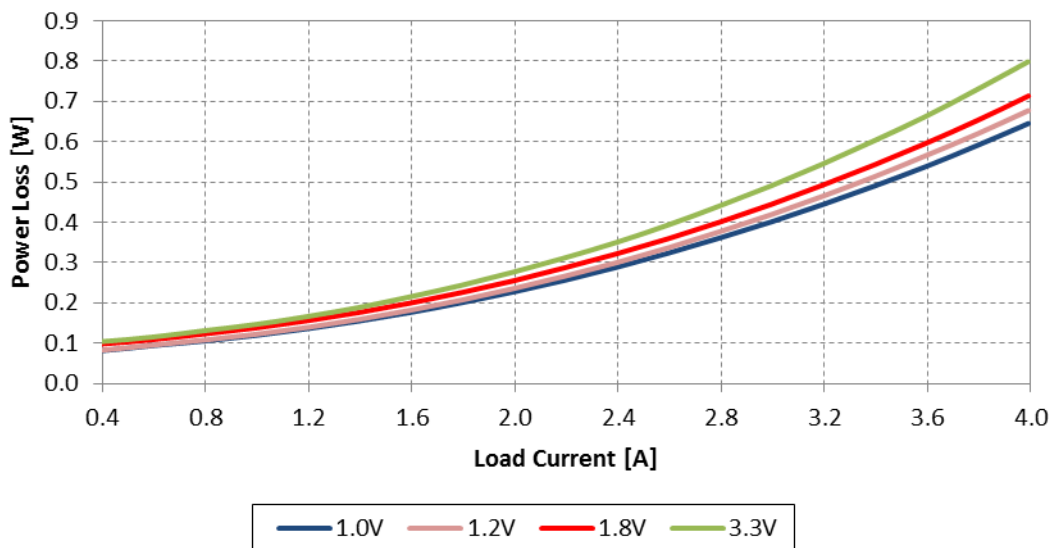
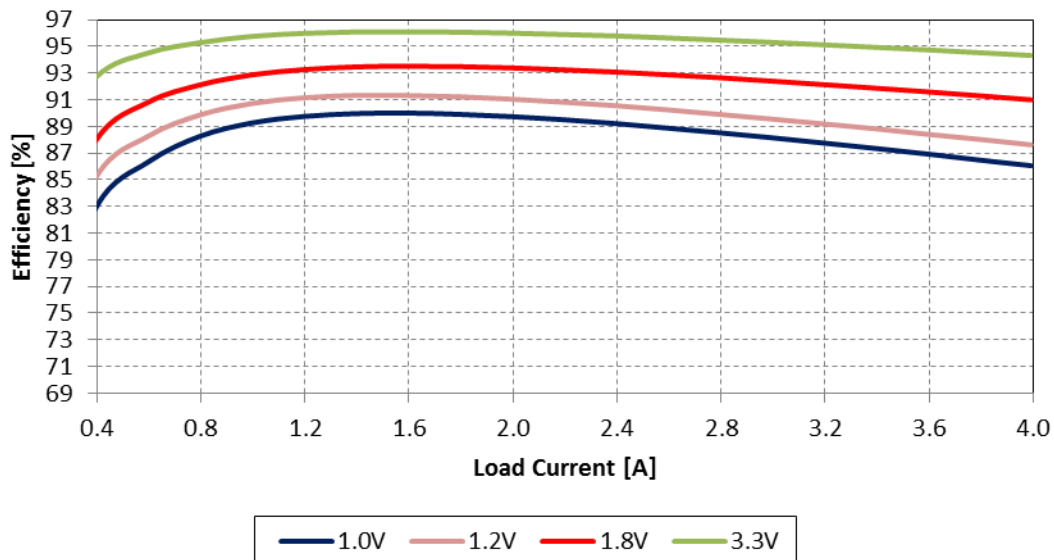

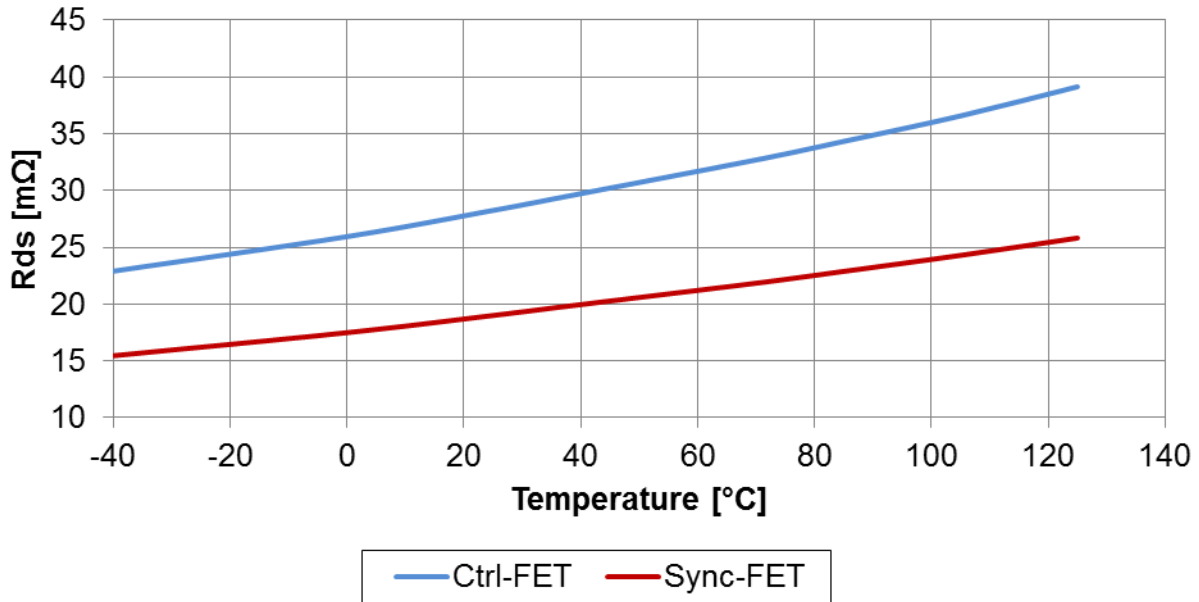
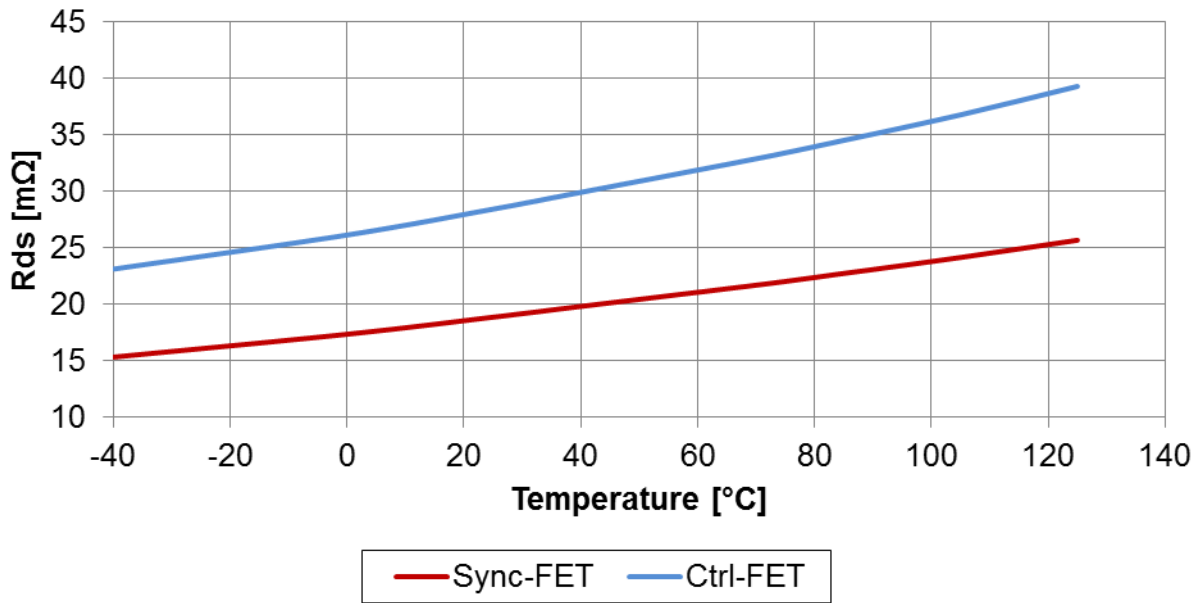
**MOSFET RDSON VARIATION OVER TEMPERATURE**
**Channel 1 : Rds(on) at Vcc = 5.3V**

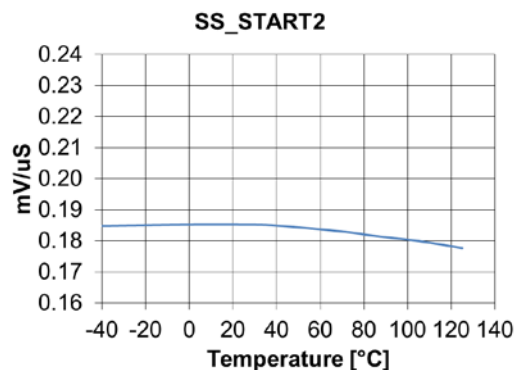
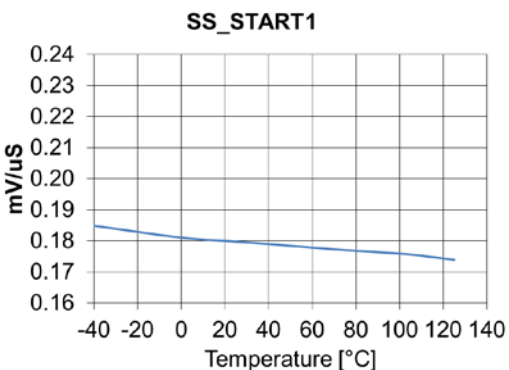
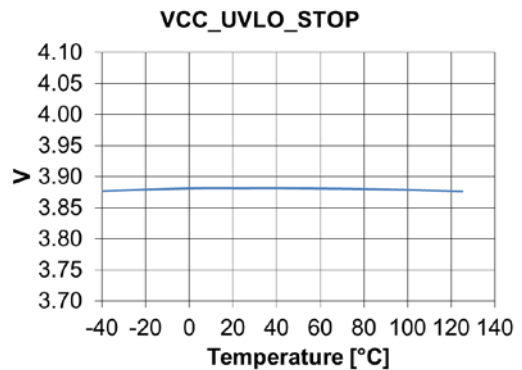
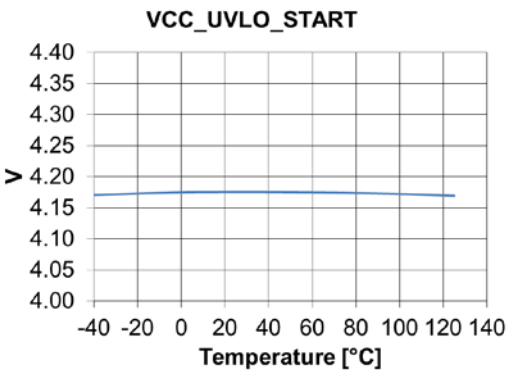
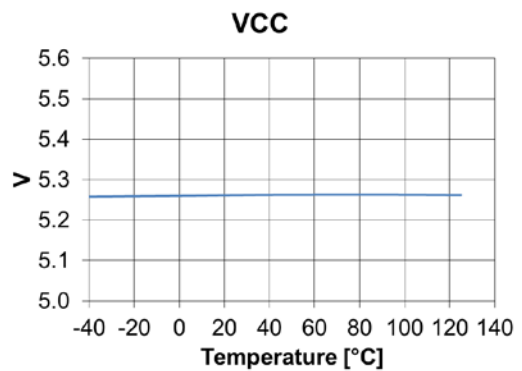
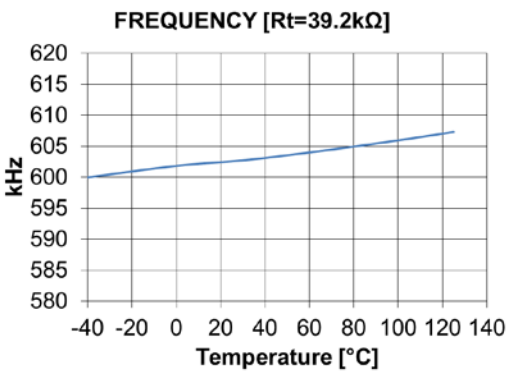
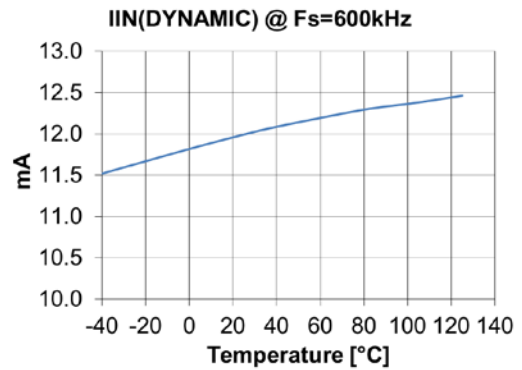
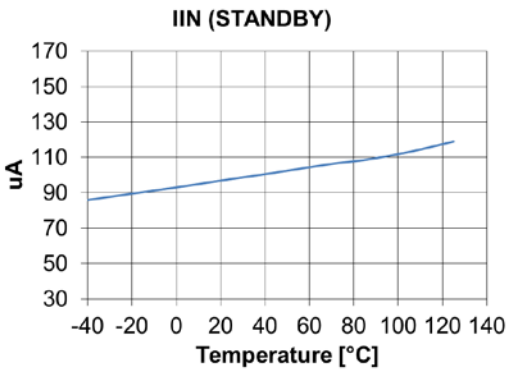
**Channel 2: Rds(on) at Vcc=5.3V**

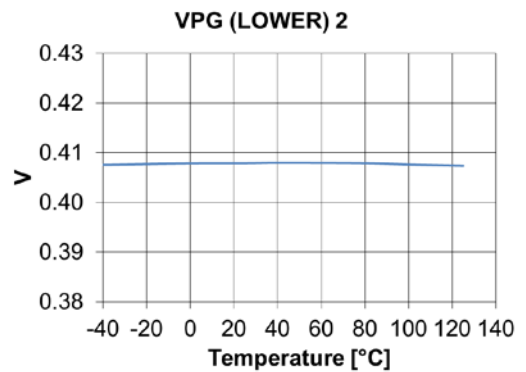
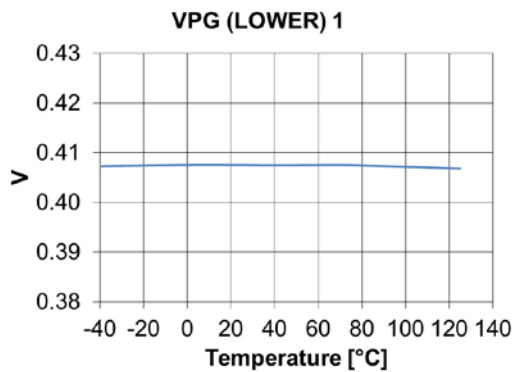
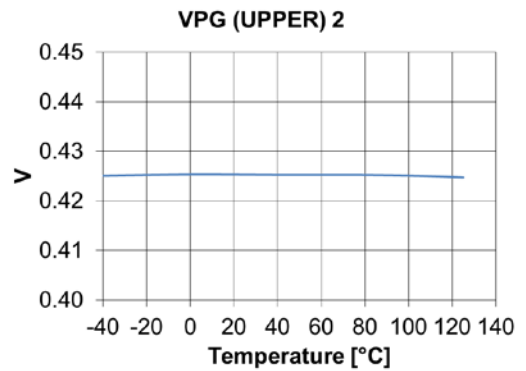
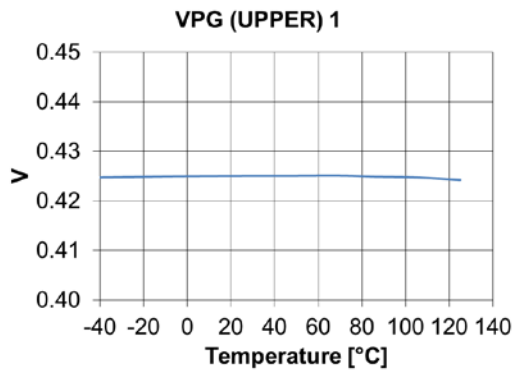
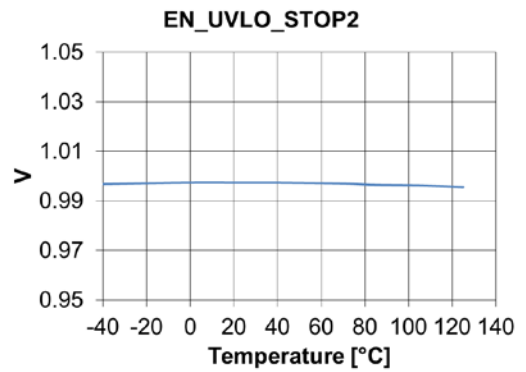
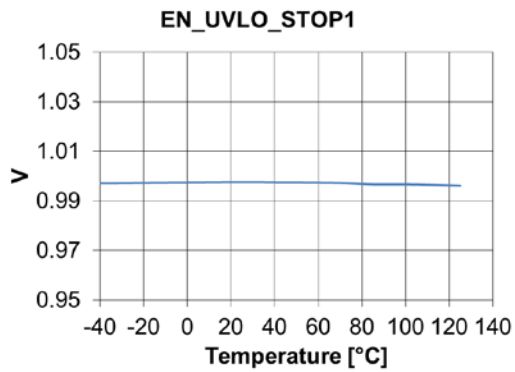
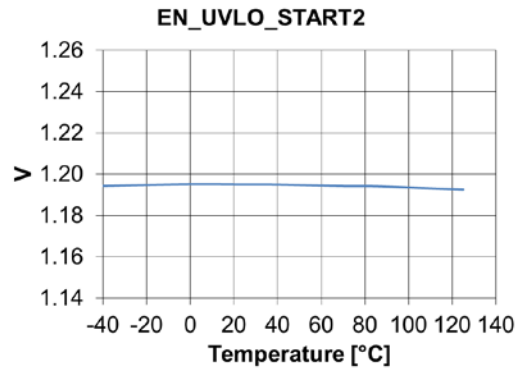
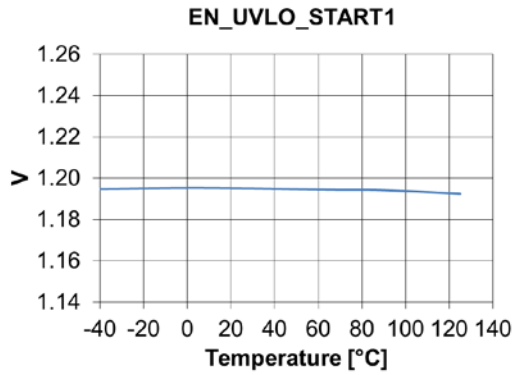
**TYPICAL OPERATING CHARACTERISTICS (-40°C TO +125°C)**

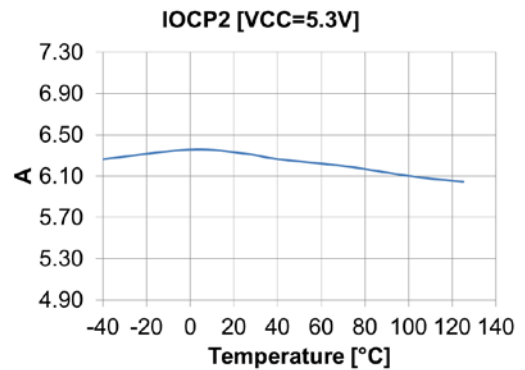
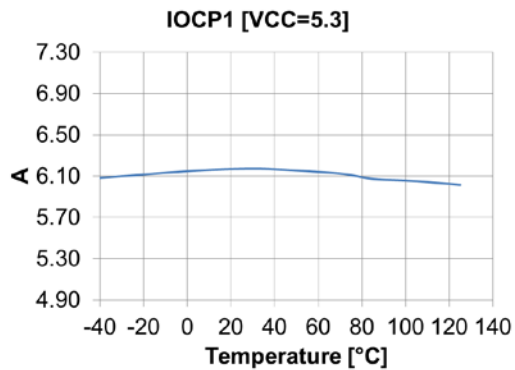
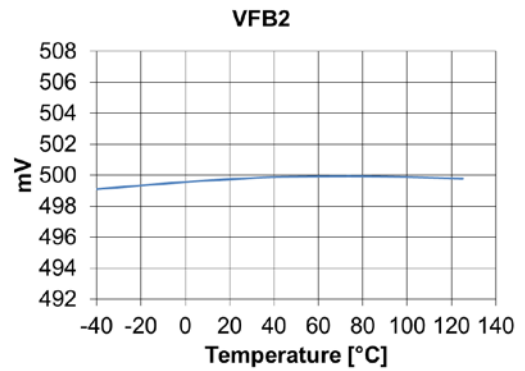
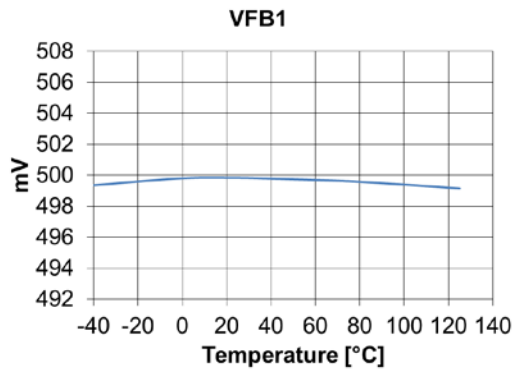
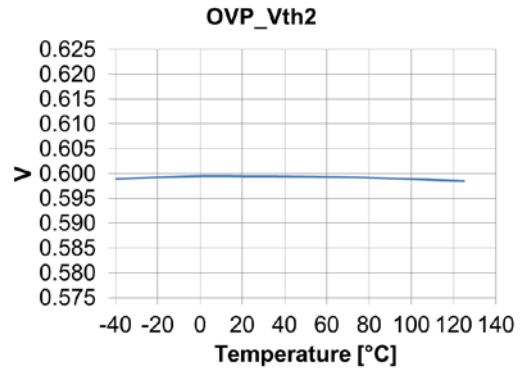
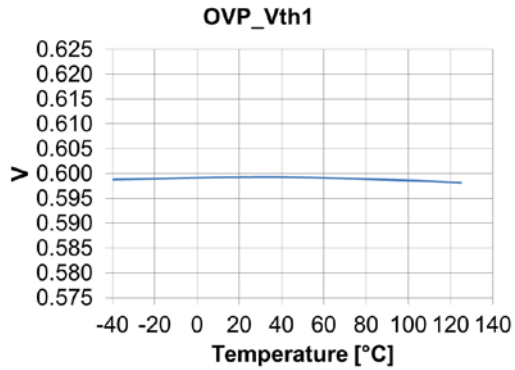



## THEORY OF OPERATION

### DESCRIPTION

The IR3891 uses a PWM voltage mode control scheme with external compensation to provide good noise immunity and maximum flexibility in selecting inductor values and capacitor types.

The switching frequency is programmable from 300KHz to 1.5MHz and provides the capability of optimizing the design in terms of size and performance.

IR3891 provides precisely regulated output voltage programmed via two external resistors from 0.5V to  $0.86 \cdot P_{Vin}$ .

The IR3891 operates with an internal low drop out regulator (LDO) which is connected to the VCC pin. This allows operation with a single supply. When using the internal LDO supply, the Vin pin should be connected the P<sub>Vin</sub> pin. If an external bias is used, it should be connected to the VCC pin and the Vin pin should be shorted to the VCC pin.

The device utilizes the on-resistance of the low side MOSFET (sync FET) as a current sense element. This method enhances the converter's efficiency and reduces cost by eliminating the need for an external current sense resistor.

IR3891 includes two low R<sub>ds(on)</sub> MOSFETs using IR's HEXFET technology. These are specifically designed for high efficiency applications.

### UNDER-VOLTAGE LOCKOUT AND POR

The under-voltage lockout circuits monitor the voltage on the VCC pin and the EN1/2 pins. They ensure that the MOSFET driver outputs remain in the off state whenever either of these signals drops below the set thresholds. Normal operation resumes once VCC and EN rise above their thresholds.

The POR (Power On Ready) signal is high when all these signals reach the valid logic level (see system block diagram).

### ENABLE

The EN pin offers another level of flexibility for startup. Each channel of the IR3891 is controlled by a separate EN pin. When the voltage at an EN pin

voltage exceeds its precise threshold (EN\_UVLO\_START), the respective channel turns on. The precise threshold allows the user to implement an Under-Voltage Lockout (UVLO) function. By deriving the EN pin voltage from the bus voltage (P<sub>Vin</sub>) through a suitable resistor divider, the user can set a P<sub>Vin</sub> threshold voltage. The resistor divider scales the P<sub>Vin</sub> voltage for the EN pin. Only after the bus voltage reaches or exceeds this level will the voltage at the Enable pin exceeds its threshold and enable the respective IR3891 channel. By connecting IR3891 in this configuration, the user can enable the part by applying P<sub>Vin</sub> and ensures the IR3891 does not turn on until the bus voltage reaches the desired level (Figure 4). Therefore, in addition to being a logic input pin that enables channels on IR3891, the EN pin also offers UVLO functionality. UVLO functionality is particularly desirable for high output voltage applications, where it is beneficial to disable the IR3891 until P<sub>Vin</sub> exceeds the desired output voltage level.

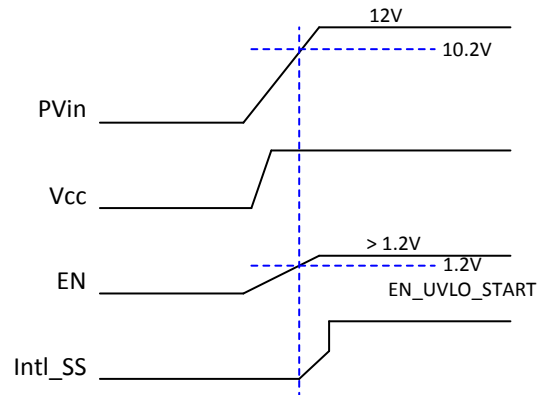

Figure 4: Normal Startup: IR3891 Channel starts when P<sub>Vin</sub> reaches 10.2V by connecting EN to P<sub>Vin</sub> using a resistor divider.

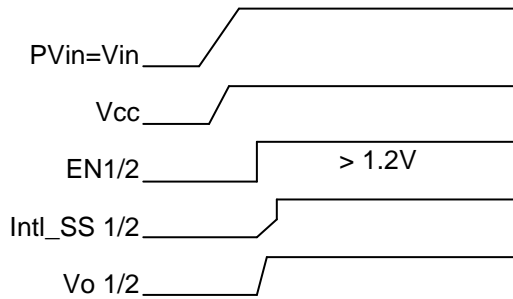

Figure 5: Recommended startup for Normal operation

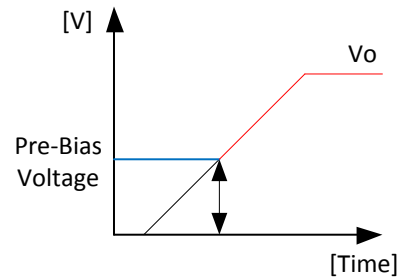

Figure 7: Pre-bias Start Up

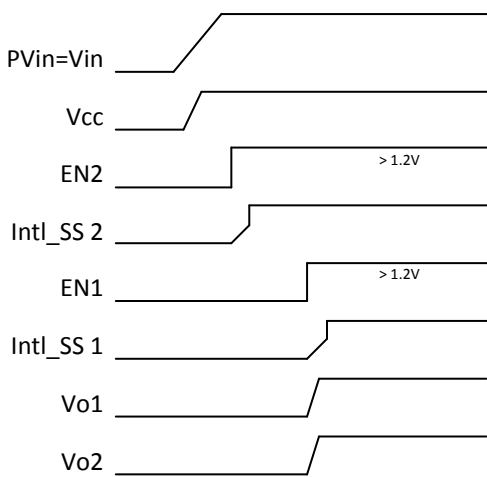

Figure 6: Recommended startup for sequencing operation (ratiometric or simultaneous)

Figure 5 shows the recommended start-up sequence for the normal (non-sequencing) operation of IR3891, when EN pins are used as a logic input. Figure 6 shows the recommended startup sequence for sequenced operation of IR3891.

### PRE-BIAS STARTUP

IR3891 begins each start up by pre-charging the output to prevent oscillation and disturbances to the output voltage. The buck converter starts in an asynchronous fashion and keeps the synchronous MOSFET (Sync FET) off until the first gate signal for control MOSFET (Ctrl FET) is generated. Figure 7 shows a typical pre-bias sequence. The sync FET always starts with a narrow pulse width (12.5% of the switching period). The pulse width increase after 16 pulses by 12.5% until the output reaches steady state value. There are 16 pulses for each step. Figure 8 shows the series of 16 x 8 startup pulses.

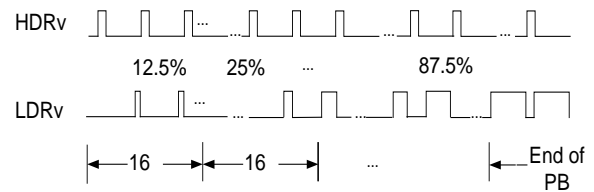

Figure 8: Pre-bias startup pulses

### SOFT-START

IR3891 has an internal digital soft-start to control the output voltage rise and to limit the current surge during start-up. To ensure the correct start-up, the soft-start sequence initiates when the EN and VCC rise above their UVLO thresholds and generates Power On Ready (POR) signal. The internal soft-start rises with the typical rate of 0.2mV/μS from 0V to 1.5V. Figure 9 shows the waveforms during soft-start. The normal Vout start-up time is fixed, and is equal to:

$$T_{start} = \frac{(0.65V - 0.15V)}{0.2mV / \mu S} = 2.5mS \quad (1)$$

During the soft-start the over-current protection (OCP) and the over-voltage protection (OVP) is enabled to protect the device from short circuit or over voltage events.

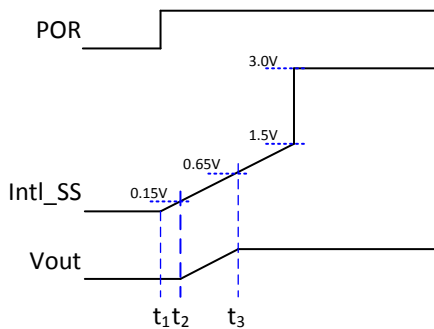

Figure 9: Theoretical operation waveforms during soft-start (non-sequencing)

### OPERATING FREQUENCY

The switching frequency can be programmed between 300KHz-1.5MHz by connecting an external resistor from Rt/Sync pin to GND. Table 1 tabulates the oscillator frequency versus  $R_t$ .

Table 1: Switching Frequency ( $F_s$ ) vs. External Resistor ( $R_t$ )

$R_t$ (K $\Omega$ )	Freq (KHz)
80.6	300
60.4	400
48.7	500
39.2	600
34	700
29.4	800
26.1	900
23.2	1000
21	1100
19.1	1200
17.4	1300
16.2	1400
15	1500

### EXTERNAL SYNCHRONIZATION

IR3891 incorporates an internal phase lock loop (PLL) circuit which enables synchronization of the internal oscillator to an external clock. This function is important to avoid sub-harmonic oscillations due to beat frequency for embedded systems when multiple point-of-load (POL) regulators are used. A multiple-function pin, Rt/Sync, is used to connect the external clock. If the external clock is present before the converter turns on, Rt/Sync pin can be connected to

the external clock solely and no resistor is required. If the external clock is applied after the converter turns on, or the converter switching frequency needs to toggle between the external clock frequency and the internal free-running frequency, an external resistor from Rt/Sync pin to GND is required to set the free running frequency.

When an external clock is applied to Rt/Sync pin after the converter runs in steady state with its free-running frequency, a transition from the free-running frequency to the external clock frequency will happen. The switching frequency gradually synchronizes to the external clock frequency regardless of which one is faster. On the contrary, when the external clock signal is removed from Rt/Sync pin, the switching frequency gradually returns to the free-running frequency. In order to minimize the impact from these transitions to output voltage, a diode is recommended to add between the external clock and Rt/Sync pin. Figure 10 shows the timing diagram of these transitions.

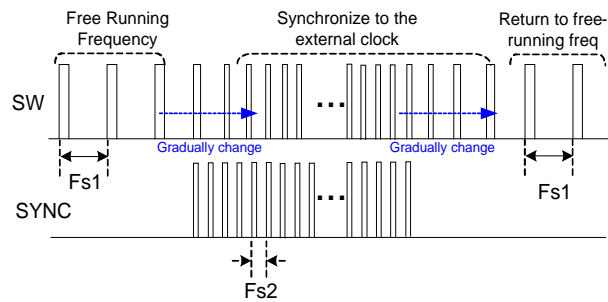

Figure 10: Timing diagram for synchronization to an external clock ( $F_s1 > F_s2$  or  $F_s1 < F_s2$ )

An internal compensation circuit is used to change the PWM ramp slope according to the clock frequency applied on Rt/Sync pin. Thus, the effective amplitude of the PWM ramp ( $V_{ramp}$ ), which is used in compensation loop calculation, has minor impact from the variation of the external synchronization signal.  $V_{in}$  variation also affects the ramp amplitude, which is discussed separately in Feed-Forward section.

### SHUTDOWN

IR3891 shutdown occurs when VCC drops below its threshold or a fault occurs. When VCC falls below VCC\_UVLO\_STOP, the part detects an UVLO event and the part turns off. Over-Voltage Protection, Over-Current Protection and Thermal Shutdown also cause the IR3891 shutdown. Faults are discussed in more detail below.

Each channel of the IR3891 can be shutdown separately by pulling the channel EN pin below its low threshold. Each EN pin controls only one channel to allow the user to operate each independently.

### OVER CURRENT PROTECTION (CURRENT LIMIT AND HICCUP MODE)

The over-current protection is performed by sensing current through the  $R_{DS(on)}$  of the Sync FET. This method enhances the converter's efficiency and reduces cost by eliminating a current sense resistor. The current limit is pre-set internally and compensated to maintain an almost constant limit over temperature.

IR3891 determines over-current events when the Synchronous FET is on. OCP circuit samples this current for 40 nsec typically after the rising edge of the PWM set pulse which has a width of 12.5% of the switching period. The PWM pulse starts at the falling edge of the PWM set pulse. This makes valley current sense more robust as current is sensed close to the bottom of the inductor downward slope where transient and switching noise are lower and helps to prevent false tripping due to noise and transient. An OC condition is detected if the load current exceeds the threshold, the converter enters into hiccup mode. PGood will go low and the internal soft start signal will be pulled low.

$$I_{OCP} = I_{LIMIT} + \frac{\Delta i}{2} \quad (2)$$

$I_{OCP}$  = DC current limit hiccup point  
 $I_{LIMIT}$  = Current Limit Valley Point  
 $\Delta i$  = Inductor ripple current

Hiccup mode is when the converter stops and waits before restarting. The channel waits for Tblk\_Hiccup, 2.48 ms typical, before the OC signal resets and restarts. In normal application, the converter restarts with a pre-bias sequence and soft-start. Figure 11 shows the timing diagram of the above OC protection. If another OC event is detected, the part repeats hiccup mode.

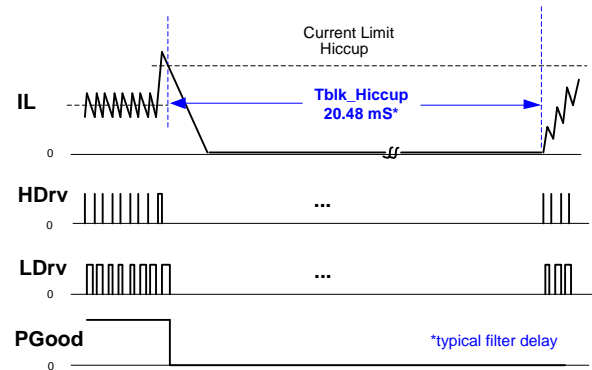

Figure 11: Timing diagram for pulse-by-pulse current limit and Hiccup mode

### THERMAL SHUTDOWN

IR3891 provides thermal protection. A thermal fault is detected, when the temperature of the part reaches the Thermal Shutdown Threshold, 145°C typical. A thermal fault results in both channels turning off. The power MOSFETs are disabled during thermal shutdown. IR3891 automatically restarts when the temperature of the part drops back below the lower thermal limit, typically 20°C below the Thermal Shutdown Threshold.

### FEED-FORWARD

Feed-Forward is an important feature which helps with stability and preserves load transient performance during P<sub>Vin</sub> changes. In IR3891, Feed-Forward (F.F.) function is enabled when Vin pin is connected to P<sub>Vin</sub> pin and Vin > 5.0V. The PWM ramp amplitude (V<sub>ramp</sub>) is proportionally changed with respect to Vin to maintain P<sub>Vin</sub>/V<sub>ramp</sub> ratio. The ratio is almost constant throughout the Vin range (as shown in Figure 12). By maintaining a constant P<sub>Vin</sub>/V<sub>ramp</sub>, the control loop bandwidth and phase margin are more constant. F.F. function also helps minimize the effect of P<sub>Vin</sub> changes on the output voltage.

Feed-Forward is based on the Vin voltage and needs to be accounted for when calculating IR3891 compensation. The P<sub>Vin</sub>/V<sub>ramp</sub> ratio is not maintained when Vin and P<sub>Vin</sub> are not equal. This is the case when an external bias voltage for VCC. When using an external VCC voltage, Vin pin should be connected to the VCC pin instead of the P<sub>Vin</sub> pin. Compensation for the configuration should reflect the separation.

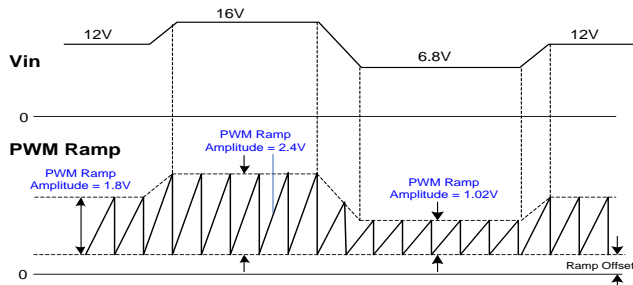

Figure 12: Timing diagram for Feed Forward (F.F.) Function

### LOW DROPOUT REGULATOR (LDO)

IR3891 has an integrated low dropout (LDO) regulator which can provide gate drive voltage for both drivers. When using an internally biased configuration, the LDO draws from the Vin pin and provides a 5.3V (typ.), as shown in Figure 13. Vin and PVin can be connected together as shown in the internally biased single rail configuration, Figure 14.

An external bias configuration can provide gate drive voltage for the drivers instead of the internal LDO. To use an external bias, connected to Vin and VCC to the external bias, as shown in Figure 15. PVin can also be connected or a different rail can be used.

When using multiple rail configurations, calculate the compensation V<sub>ramp</sub> associated with Vin. V<sub>ramp</sub> is derived from Vin which can be different from PVin, refer to Feed-Forward section.

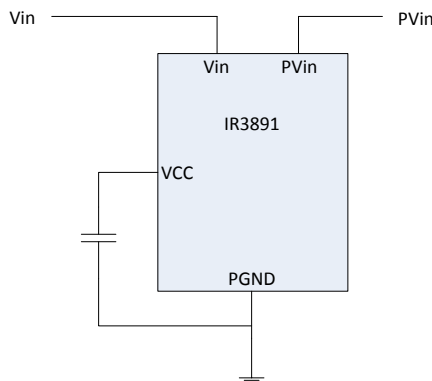

Figure 13: Internally Biased Configuration

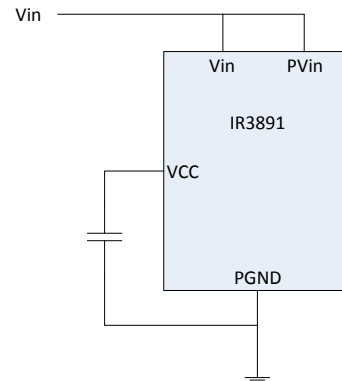

Figure 14: Internally Biased Single Rail Configuration

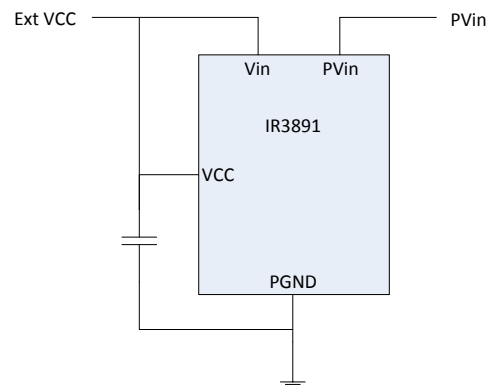

Figure 15: Externally Biased Configuration

### OUTPUT VOLTAGE SEQUENCING

IR3891 can accommodate user sequencing options using Seq, EN1/2, and PGood1/2 pins. In the block diagram presented on page 3, the error-amplifier (E/A) has been depicted with three positive inputs. Ideally, the input with the lowest voltage is used for regulating the output voltage and the other two inputs are ignored. In practice the voltages of the other two inputs should be at least 200mV greater than the referenced voltage input so that their effects can completely be ignored.

In normal operating condition, the IR3891 channels initially follow their internal soft-starts (Intl\_SS) and then references VREF. After Enable goes high, Intl\_SS begins to ramp up from 0V. The FB pin follows the Intl\_SS until it approaches VREF where the E/A starts to reference the VREF instead of the Intl\_SS (refer to Figure 16). VREF and Seq are not referenced initially because they are higher than Intl\_SS. VREF is 0.5V, typical. Seq is internally pulled

up to approximately 3.3V when left floating in normal operation and only used by channel 2.

In sequencing mode of operation, Vout2 is initially regulated with the Seq pin. Vout2 ramps up similar to the normal operation, but Intl\_SS is replaced with Seq. Seq is kept to ground level until Intl\_SS signal reaches its final value. FB2 follows Seq, until Seq approaches VREF where the E/A switches reference to the VREF. Vout2 is then regulated with respect to internal VREF (refer to Figure 17). The final Seq voltage should be between 0.7V and 3.3V.

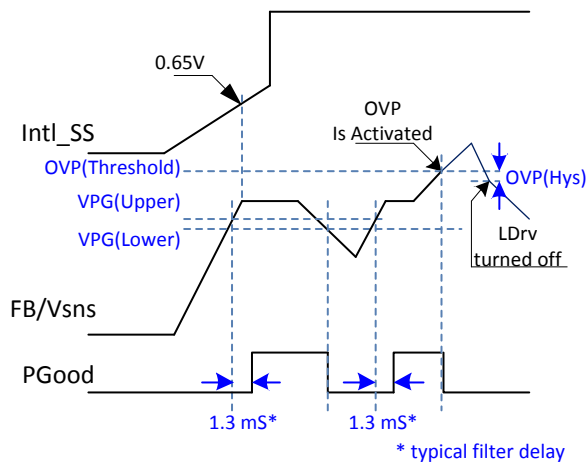

Figure 16: Timing Diagram for Output Sequence

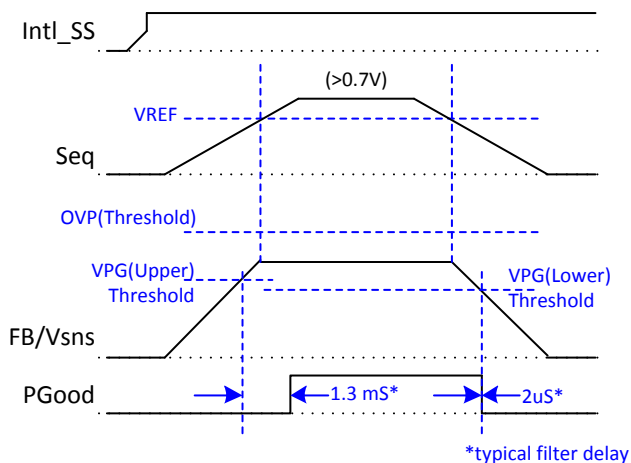

Figure 17: Timing Diagram for Sequence Startup (Seq ramping up/down)

IR3891 can perform simultaneous or ratiometric sequencing operations. Simultaneous sequencing is when the both outputs rise at the same rate. During Ratiometric sequencing, the ratio of the two outputs is

held constant during power-up. Figure 19 shows examples of the two sequencing modes.

IR3891 uses a single configuration to implement both mode of sequencing operations. Figure 18 shows the typical circuit configuration for both modes of sequencing operation. The sequencing mode is determined by the  $R_A/R_B$ ,  $R_E/R_F$ , and  $R_C/R_D$  ratios. If  $R_E/R_F = R_C/R_D$ , simultaneous startup is achieved. Vout2 follows Vout1 until the voltage at the Seq pin reaches VREF. After the voltage at the Seq pin exceeds VREF, VREF dictates Vout2. In ratiometric startup, Vout2 rises at a slower rate than Vout1. The resistor values are set up in the following way,  $R_A/R_B > R_E/R_F > R_C/R_D$ .

Table 2 summarizes the required conditions to achieve simultaneous or ratiometric sequencing operations.

Table 2: Required Conditions for Simultaneous / Ratiometric Tracking and Sequencing

Operating Mode	Seq	Required Condition
Normal (Non-sequencing, Non-tracking)	Floating	—
Simultaneous Sequencing	Ramp up from 0V	$R_A/R_B > R_E/R_F = R_C/R_D$
Ratiometric Sequencing	Ramp up from 0V	$R_A/R_B > R_E/R_F > R_C/R_D$

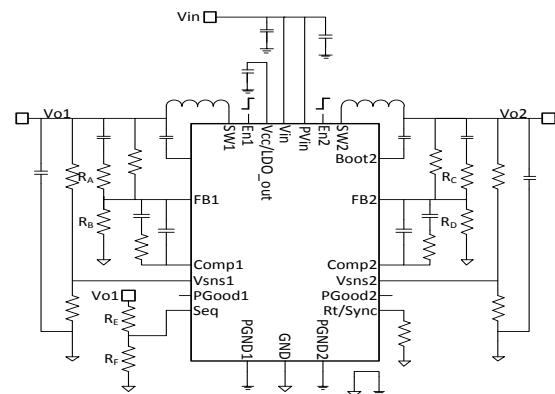

Figure 18: Application Circuit for Simultaneous and Ratiometric Sequencing

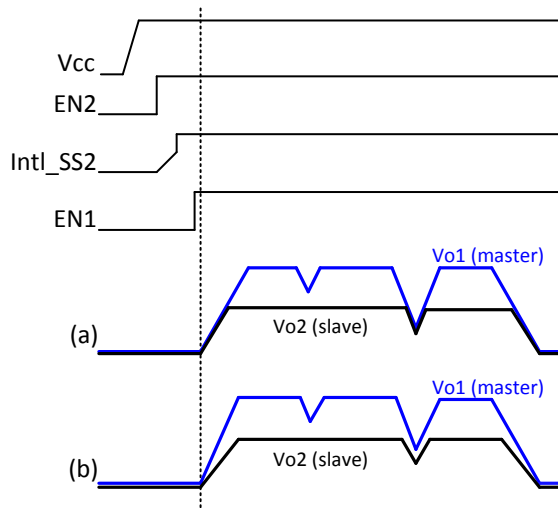

Figure 19: Typical waveforms for sequencing mode of operation: (a) simultaneous, (b) ratiometric

### OVER-VOLTAGE PROTECTION (OVP)

Over-Voltage protection (OVP) disables the channel when the output voltage exceeds the over-voltage threshold. IR3891 achieves OVP by comparing Vsns pin to the internal over-voltage threshold set at OVP(threshold),  $1.2 \cdot V_{REF}$  typical. Vsns voltage is determined by an external voltage divider resistor network connected to the output in typical application. When Vsns exceeds the over-voltage threshold, an over-voltage is detected and OV signal asserts after OVP(delay). The high side drive signal HDrv is turned off immediately and PGood flags low. The low side drive signal is kept on until the Vsns voltage drops below the lower threshold. After that, HDrv is latched off until a reset is performed by cycling either VCC or the respective EN.

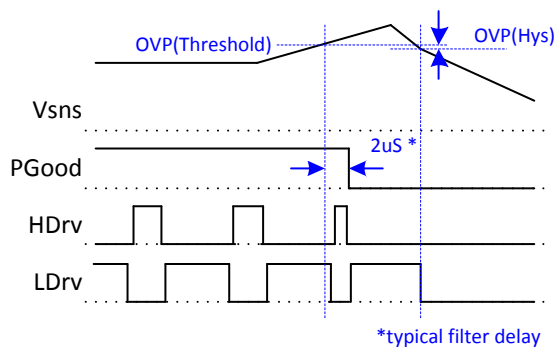

Figure 20: Timing diagram for OVP

### OPEN FEEDBACK-LOOP PROTECTION

Open Feedback Loop protection (OFLP) is devised to shutdown the channel in case the feedback is broken. OFLP is activated when the Vsns is above the VPG(upper) threshold,  $0.85 \cdot V_{REF}$  typical, and remains active while Vsns is above the VPG(lower) threshold,  $0.80 \cdot V_{REF}$ . When FB drop below OFLP(threshold) threshold,  $0.70 \cdot V_{REF}$ , OFLP disables switching and pulls down on PGood. The part remains disabled until FB rises above OFLP(threshold) plus OFLP(Hys),  $0.75 \cdot V_{REF}$ . This function does not latch the part off nor does it require an EN or a VCC toggle to re-enable the part.

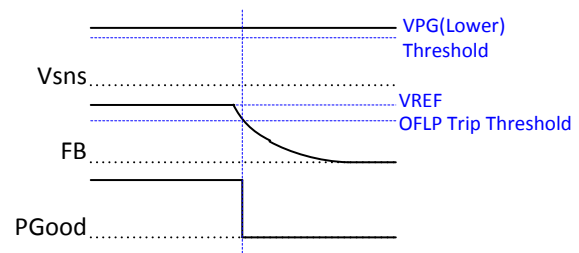

Figure 21: Timing Diagram for Open Feedback Line Protection (OFLP)

### POWER GOOD OUTPUT

PGood is an open drain pin that monitors the UV, FAULT and the POR signals. PGood signal asserts approximately 1.3mS, after Vsns rises above VGP(Upper) threshold,  $0.85 \cdot V_{REF}$  typical, while FAULT is low and POR is high. It remains asserted while FAULT is low and POR is high and Vsns stays above VGP(Lower) threshold,  $0.80 \cdot V_{REF}$  typical. When Vsns falls below VGP(Lower) threshold there is a typical  $2 \mu\text{S}$  delay before PGood goes low. The two PGood signals are independent of each other and are set according to their respective channel.

### SWITCH NODE PHASE SHIFT

The two converters on the IR3891 run interleaving phases by  $180^\circ$  to reduce input filter requirements. The two converters are synchronized to the user programmable oscillator. Channel 1 runs in phase with the oscillator while channel 2 runs out of phase. Staggering the switching cycles reduces the time the converters draw current from the supply simultaneously. The pulses of current drawn from the input induce voltage ripples across the input capacitor. The voltage ripple shapes are dependent on the different loading and output voltages of the two converters. By switching the converters at different times, the magnitude of voltage ripples reduces and input filter requirements become less stringent.

### MINIMUM ON-TIME CONSIDERATIONS

The minimum on-time is the shortest amount of time which the Control FET may be reliably turned on. Internal delays and gate drive make up a large portion of the minimum on-time. IR3891 has a minimum on-time of 60nS.

Any design or application using IR3891 should operation with a pulse width greater than minimum on-time. This is necessary for the circuit to operate without jitter and pulse-skipping, which can cause high inductor current ripple and high output voltage ripple.

$$t_{on} = \frac{D}{F_s} = \frac{V_{out}}{PV_{in} \times F_s} \quad (3)$$

In any application that uses IR3891, the following condition must be satisfied:

$$t_{on(min)} \leq t_{on} \quad (4)$$

$$t_{on(min)} \leq \frac{V_{out}}{PV_{in} \times F_s} \quad (5)$$

$$\therefore PV_{in} \times F_s \leq \frac{V_{out}}{t_{on(min)}} \quad (6)$$

The minimum output voltage is limited by the reference voltage and hence  $V_{out(min)} = 0.5V$ . For  $V_{out(min)} = 0.5V$ ,

$$\therefore PV_{in} \times F_s \leq \frac{V_{out}}{t_{on(min)}} \quad (7)$$

$$\therefore PV_{in} \times F_s \leq \frac{0.5V}{60nS} = 8.33V / \mu S$$

Therefore, with an input voltage 16V and minimum output voltage, the converter should be designed for switching frequency not to exceed 520kHz. Conversely, the input voltage (PVin) should not exceed 5.55V for operation at the maximum recommended operating frequency (1.5MHz) and minimum output voltage (0.5V). Increasing the PVin greater than 5.55V will cause pulse skipping.

### MAXIMUM DUTY RATIO

Maximum duty ratio is lower at higher frequencies and higher Vin voltages. A maximum off-time of 250nS is specified for IR3891. This provides an upper limit on the operating duty ratio at any given switching frequency. The off-time becomes a larger percentage of the switching period when high switching frequencies are used. Thus, a lower the maximum duty ratio can be achieved when frequencies increase.

Feed-Forward from the Vin voltage placed a limitation on the maximum duty cycle by saturating the compensation ramp. By maintaining a constant Vin/Vramp, the effective Vramp voltage is increased while the maximum range is remains the same. The ramp reaches the maximum limit before reaching the expected level. Reaching the maximum limit ends the switching cycle prematurely and results in a lower maximum duty cycle.

Maximum duty cycle is dependent on the Vin and switching frequency. Figure 22 is a theoretical plot of the maximum duty cycle vs. the switching frequency using typical parameter values. It shows how the maximum duty cycle is influenced by the Vin and the switching frequency.

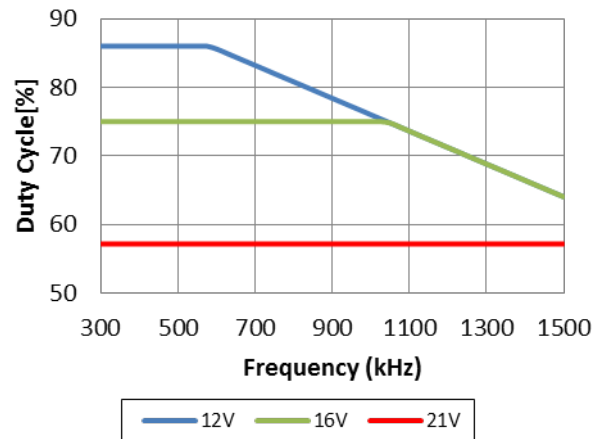

Figure 22: Maximum Duty Cycle vs. Switching Frequency

## DESIGN EXAMPLE

The following example is a typical application for IR3891. The application circuit is shown in

$$V_{in} = PV_{in} = 12V \text{ (21V Max)}$$

$$F_s = 600kHz$$

Channel 1:

$$V_o = 1.8V$$

$$I_o = 4A$$

$$\text{Ripple Voltage} = \pm 1\% * V_o$$

$$\Delta V_o = \pm 5\% * V_o \text{ (for 50\% load transient)}$$

Channel 2:

$$V_o = 1.2V$$

$$I_o = 4A$$

$$\text{Ripple Voltage} = \pm 1\% * V_o$$

$$\Delta V_o = \pm 5\% * V_o \text{ (for 50\% load transient)}$$

### Enabling the IR3891

As explained earlier, the precise threshold of the Enable lends itself well to implementation of a UVLO for the Bus Voltage as shown in Figure 23.

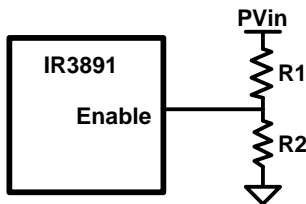

Figure 23: Using Enable pin for UVLO implementation

For a typical Enable threshold of  $V_{EN} = 1.2V$

$$PV_{in(min)} \times \frac{R_2}{R_1 + R_2} = V_{EN} = 1.2 \quad (8)$$

$$R_2 = R_1 \frac{V_{EN}}{PV_{in(min)} - V_{EN}} \quad (9)$$

For  $PV_{in(min)} = 9.2V$ ,  $R_1 = 49.9K$  and  $R_2 = 7.5K$  ohm is a good choice.

### Programming the frequency

For  $F_s = 600$  kHz, select  $R_f = 39.2$  K $\Omega$ , using Table 1.

### Output Voltage Programming

Output voltage is programmed by reference voltage and external voltage divider. The FB pin is the inverting input of the error amplifier, which is internally referenced to VREF. The divider ratio is set to equal VREF at the FB pin when the output is at its desired value. When an external resistor divider is connected to the output as shown in Figure 24, the output voltage is defined by using the following equation:

$$V_o = V_{ref} \times \left( 1 + \frac{R_5}{R_6} \right) \quad (10)$$

$$R_6 = R_5 \times \left( \frac{V_{ref}}{V_o - V_{ref}} \right) \quad (11)$$

For the calculated values of R5 and R6, see feedback compensation section.

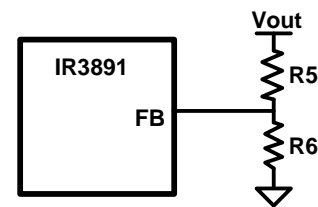

Figure 24: Typical application of the IR3891 for programming the output voltage

### Bootstrap Capacitor Selection

To drive the Control FET, it is necessary to supply a gate voltage at least 4V greater than the voltage at the SW pin, which is connected to the source of the Control FET. This is achieved by using a bootstrap configuration, which comprises the internal bootstrap diode and an external bootstrap capacitor (C1). The operation of the circuit is as follows: When the sync FET is turned on, the capacitor node connected to SW is pulled down to ground. The capacitor charges towards  $V_{cc}$  through the internal bootstrap diode (Figure 25), which has a forward voltage drop  $V_D$ . The voltage  $V_c$  across the bootstrap capacitor C1 is approximately given as:

$$V_c \cong V_{cc} - V_D \quad (12)$$

When the control FET turns on in the next cycle, the capacitor node connected to SW rises to the bus voltage  $V_{in}$ . However, if the value of C1 is appropriately chosen, the voltage  $V_c$  across C1 remains approximately unchanged and the voltage at the Boot pin becomes:

$$V_{Boot} \cong V_{in} + V_{cc} - V_D \quad (13)$$

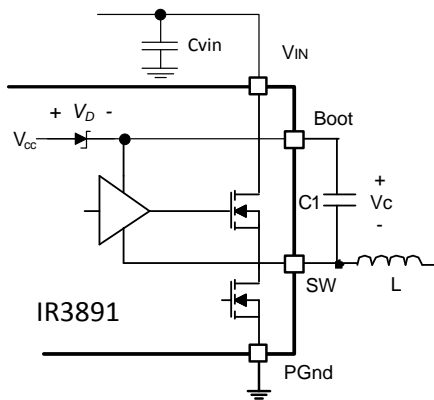

Figure 25: Bootstrap circuit to generate  $V_c$  voltage

A bootstrap capacitor of value 0.1 $\mu$ F is suitable for most applications.

### Input Capacitor Selection

The ripple currents generated during the on time of the control FETs should be provided by the input capacitor. The RMS value of this ripple for each channel is expressed by:

$$I_{RMS} = I_o \times \sqrt{D \times (1 - D)} \quad (14)$$

$$D = \frac{V_o}{V_{in}} \quad (15)$$

Where:

$D$  is the Duty Cycle

$I_{RMS}$  is the RMS value of the input capacitor current.

$I_o$  is the output current.

For channel 1,  $I_o=4A$  and  $D = 0.15$ , the  $I_{RMS} = 1.43A$ .

For channel 2,  $I_o=4A$  and  $D = 0.1$ , the  $I_{RMS} = 1.2A$ .

Ceramic capacitors are recommended due to their peak current capabilities. They also feature low ESR and ESL at higher frequency which enables better efficiency. For this application, it is advisable to have 4x10 $\mu$ F, 25V ceramic capacitors, C3216X5R1E106K from TDK. In addition to these, although not mandatory, a 1x330 $\mu$ F, 25V SMD capacitor EEV-FK1E331P from Panasonic may also be used as a bulk capacitor and is recommended if the input power supply is not located close to the converter.

### Inductor Selection

Inductors are selected based on output power, operating frequency and efficiency requirements. A low inductor value causes large ripple current, resulting in the smaller size, faster response to a load transient but may reduce efficiency and cause higher output noise. Generally, the selection of the inductor value can be reduced to the desired maximum ripple current in the inductor ( $\Delta i$ ). The optimum point is usually found between 20% and 50% ripple of the output current. For the buck converter, the inductor value for the desired operating ripple current can be determined using the following relation:

$$V_{in} - V_o = L \times \frac{\Delta i}{\Delta t}; \Delta t = D \times \frac{1}{F_s}$$

$$L = (V_{in} - V_o) \times \frac{V_o}{V_{in} \times \Delta i \times F_s} \quad (16)$$

Where:

$V_{in}$  = Maximum input voltage

$V_o$  = Output Voltage

$\Delta i$  = Inductor Peak-to-Peak Ripple Current

$F_s$  = Switching Frequency

$\Delta t$  = On time for Control FET

$D$  = Duty Cycle

If  $\Delta i \approx 20\% \times I_o$ , then the channel 1 output inductor is calculated to be 3.2 $\mu$ H. Select  $L=2.2\mu H$ , PCMB065T-2R2MS, from Cynotec which provides a compact, low profile inductor suitable for this application. For channel 2, the output inductor is calculated to be 2.25 $\mu$ H. Select  $L=1.5\mu H$ , PCMB065T-1R5MS, from Cynotec.

### Output Capacitor Selection

The voltage ripple and transient requirements determine the output capacitors type and values. The criterion is normally based on the value of the

Effective Series Resistance (ESR). However the actual capacitance value and the Equivalent Series Inductance (ESL) are other contributing components. These components can be described as:

$$\begin{aligned} \Delta V_o &= \Delta V_{o(ESR)} + \Delta V_{o(ESL)} + \Delta V_{o(C)} \\ \Delta V_{o(ESR)} &= \Delta I_L \times ESR \\ \Delta V_{o(ESL)} &= \left( \frac{V_m - V_o}{L} \right) \times ESL \\ \Delta V_{o(C)} &= \frac{\Delta I_L}{8 \times C_o \times F_s} \end{aligned} \quad (17)$$

Where:

$\Delta V_o$  = Output Voltage Ripple  
 $\Delta I_L$  = Inductor Ripple Current

Since the output capacitor has a major role in the overall performance of the converter and determines the result of transient response, selection of the capacitor is critical. The IR3891 can perform well with all types of capacitors.

As a rule, the capacitor must have low enough ESR to meet output ripple and load transient requirements.

The goal for this design is to meet the voltage ripple requirement in the smallest possible capacitor size. Therefore it is advisable to select ceramic capacitors due to their low ESR and ESL and small size. Four of TDK C2012X5R0J226M (22uF/0805/X5R/6.3V) capacitors is a good choice for channel 1 and channel 2.

It is also recommended to use a 0.1µF ceramic capacitor at the output for high frequency filtering.

### Feedback Compensation

The IR3891 is a voltage mode controller. The control loop is a single voltage feedback path including error amplifier and error comparator. To achieve fast transient response and accurate output regulation, a compensation circuit is necessary. The goal of the compensation network is to have a stable closed-loop transfer function with a high crossover frequency and phase margin greater than 45°.

The output LC filter introduces a double pole, -40dB/decade gain slope above its corner resonant frequency, and a total phase lag of 180°. The resonant frequency of the LC filter is expressed as follows:

$$F_{LC} = \frac{1}{2 \times \pi \times \sqrt{L_o \times C_o}} \quad (18)$$

Figure 26 shows gain and phase of the LC filter. Since we already have 180° phase shift from the output filter alone, the system runs the risk of being unstable.

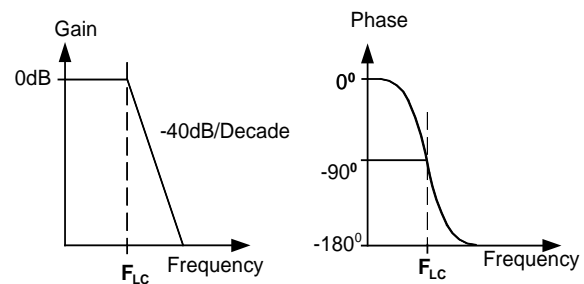

Figure 26: Gain and Phase of LC filter

The IR3891 uses a voltage-type error amplifier with high-gain and high-bandwidth. The output of the amplifier is available for DC gain control and AC phase compensation.

The error amplifier can be compensated either in type II or type III compensation.

Local feedback with Type II compensation is shown in Figure 27.

This method requires that the output capacitor should have enough ESR to satisfy stability requirements. If the output capacitor's ESR generates a zero at 5kHz to 50kHz, the zero generates acceptable phase margin and the Type II compensator can be used.

The ESR zero of the output capacitor is expressed as follows:

$$F_{ESR} = \frac{1}{2 \times \pi \times ESR \times C_o} \quad (19)$$

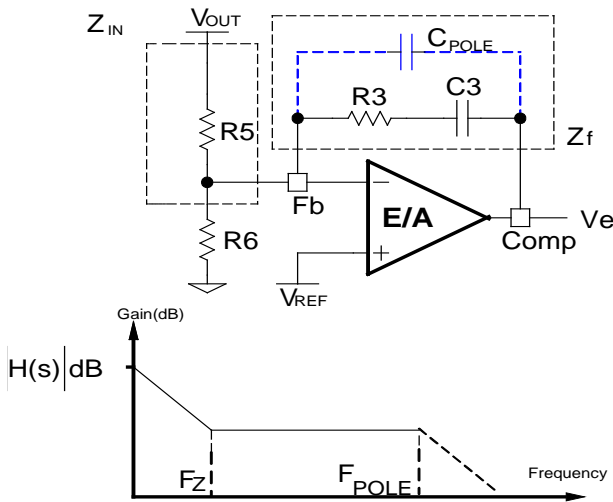

Figure 27: Type II compensation network and its asymptotic gain plot

The transfer function ( $V_e/V_{out}$ ) is given by:

$$\frac{V_e}{V_{out}} = H(s) = -\frac{Z_f}{Z_{IN}} = -\frac{1 + sR_3C_3}{sR_5C_3} \quad (20)$$

The (s) indicates that the transfer function varies as a function of frequency. This configuration introduces a gain and zero, expressed by:

$$|H(s)| = \frac{R_3}{R_5} \quad (21)$$

$$F_z = \frac{1}{2 \times \pi \times R_3 \times C_3} \quad (22)$$

First select the desired zero-crossover frequency ( $F_o$ ):

$$F_o > F_{ESR} \text{ and } F_o \leq (1/5 \sim 1/10) \times F_s \quad (23)$$

Use the following equation to calculate R3:

$$R_3 = \frac{V_{ramp} \times F_o \times F_{ESR} \times R_5}{V_{in} \times F_{LC}^2} \quad (24)$$

Where:

- $V_{in}$  = Maximum Input Voltage
- $V_{ramp}$  = Amplitude of the oscillator Ramp Voltage
- $F_o$  = Crossover Frequency
- $F_{ESR}$  = Zero Frequency of the Output Capacitor

$F_{LC}$  = Resonant Frequency of the Output Filter

$R_5$  = Feedback Resistor

To cancel one of the LC filter poles, place the zero before the LC filter resonant frequency pole:

$$F_z = 75\% \times F_{LC}$$

$$F_z = 0.75 \times \frac{1}{2 \times \pi \times \sqrt{L_o \times C_o}} \quad (25)$$

Use equation (22), (23) and (24) to calculate C3.

One more capacitor is sometimes added in parallel with C3 and R3. This introduces one more pole which is mainly used to suppress the switching noise.

The additional pole is given by:

$$F_p = \frac{1}{2 \times \pi \times \frac{C_3 \times C_{POLE}}{C_3 + C_{POLE}}} \quad (26)$$

The pole sets to one half of the switching frequency which results in the capacitor  $C_{POLE}$ :

$$C_{POLE} = \frac{1}{\pi \times R_3 \times F_s - \frac{1}{C_3}} \cong \frac{1}{\pi \times R_3 \times F_s} \quad (27)$$

For an unconditional stability general solution using any type of output capacitors with a wide range of ESR values, use local feedback with type III compensation network. Type III compensation network is typically used for voltage-mode controller as shown in Figure 28.

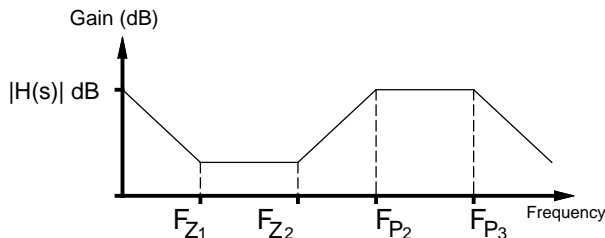
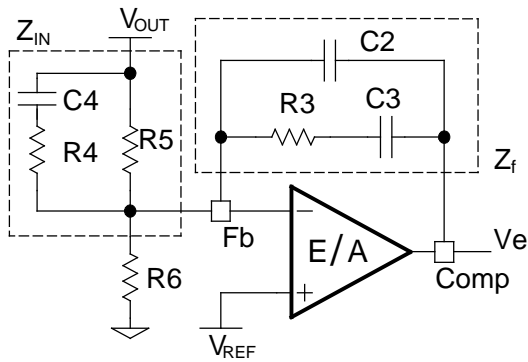

Figure 28: Type III Compensation network and its asymptotic gain plot

Again, the transfer function is given by:

$$\frac{V_e}{V_{out}} = H(s) = -\frac{Z_f}{Z_{IN}}$$

By replacing  $Z_{in}$  and  $Z_f$ , according to Figure 28, the transfer function can be expressed as:

$$H(s) = -\frac{(1 + sR_3C_3)[1 + sC_4(R_4 + R_5)]}{sR_5(C_2 + C_3) \left[ 1 + sR_3 \left( \frac{C_2 \times C_3}{C_2 + C_3} \right) \right] (1 + sR_4C_4)} \quad (28)$$

The compensation network has three poles and two zeros and they are expressed as follows:

$$F_{P1} = 0 \quad (29)$$

$$F_{P2} = \frac{1}{2\pi \times R_4 \times C_4} \quad (30)$$

$$F_{P3} = \frac{1}{2\pi \times R_3 \left( \frac{C_2 \times C_3}{C_2 + C_3} \right)} \cong \frac{1}{2\pi \times R_3 \times C_2} \quad (31)$$

$$F_{Z1} = \frac{1}{2\pi \times R_3 \times C_3} \quad (32)$$

$$F_{Z2} = \frac{1}{2\pi \times C_4 \times (R_4 \times R_5)} \cong \frac{1}{2\pi \times C_4 \times R_5} \quad (33)$$

Cross over frequency is expressed as:

$$F_o = R_3 \times C_4 \times \frac{V_{in}}{V_{ramp}} \times \frac{1}{2\pi \times L_o \times C_o} \quad (34)$$

Based on the frequency of the zero generated by the output capacitor and its ESR, relative to the crossover frequency, the compensation type can be different. Table 3 shows the compensation types for relative locations of the crossover frequency.

Table 3: Different types of compensators

Compensator Type	$F_{ESR}$ vs $F_o$	Typical Output Capacitor
Type II	$F_{LC} < F_{ESR} < F_o < F_s/2$	Electrolytic
Type III	$F_{LC} < F_o < F_{ESR}$	SP Cap, Ceramic

The higher the crossover frequency is, the potentially faster the load transient response will be. However, the crossover frequency should be low enough to allow attenuation of switching noise. Typically, the control loop bandwidth or crossover frequency ( $F_o$ ) is selected such that:

$$F_o \leq (1/5 \sim 1/10) * F_s$$

The DC gain should be large enough to provide high DC-regulation accuracy. The phase margin should be greater than  $45^\circ$  for overall stability.

The specifications for designing channel 1:

$$V_{in} = 12V$$

$$V_o = 1.8V$$

$$V_{ramp} = 1.8V \text{ (This is a function of } V_{in}, \text{ pls. see Feed-Forward section)}$$

$$V_{ref} = 0.5V$$

$$L_o = 2.2\mu H$$

$$C_o = 4x22\mu F, \text{ ESR} \approx 3m\Omega \text{ each}$$

It must be noted here that the value of the capacitance used in the compensator design must be

the small signal value. For instance, the small signal capacitance of the 22uF capacitor used in this design is 9.5uF at 1.8 V DC bias and 600 kHz frequency. It is this value that must be used for all computations related to the compensation. The small signal value may be obtained from the manufacturer's datasheets, design tools or SPICE models. Alternatively, they may also be inferred from measuring the power stage transfer function of the converter and measuring the double pole frequency  $F_{LC}$  and using equation (18) to compute the small signal  $C_o$ .

These result to:

$$F_{LC} = 17.4 \text{ kHz}$$

$$F_{ESR} = 5.6 \text{ MHz}$$

$$F_s/2 = 300 \text{ kHz}$$

Select crossover frequency  $F_o=100 \text{ kHz}$

Since  $F_{LC} < F_o < F_s/2 < F_{ESR}$ , Type III is selected to place the pole and zeros.

Detailed calculation of compensation Type III:

Desired Phase Margin  $\Theta = 70^\circ$

$$F_{Z2} = F_o \sqrt{\frac{1 - \sin \Theta}{1 + \sin \Theta}} = 17.6 \text{ kHz}$$

$$F_{P2} = F_o \sqrt{\frac{1 + \sin \Theta}{1 - \sin \Theta}} = 567.1 \text{ kHz}$$

Select:

$$F_{Z1} = 0.5 \times F_{Z2} = 8.8 \text{ kHz and}$$

$$F_{P3} = 0.5 \times F_s = 300 \text{ kHz}$$

Select  $C_4 = 2.2\text{nF}$ .

Calculate  $R_3$ ,  $C_3$  and  $C_2$ :

$$R_3 = \frac{2 \times \pi \times F_o \times L_o \times C_o \times V_{ramp}}{C_4 \times V_{in}}; R_3 = 3.6 \text{ k}\Omega,$$

Select:  $R_3 = 3.24 \text{ k}\Omega$

$$C_3 = \frac{1}{2 \times \pi \times F_{Z1} \times R_3}; C_3 = 5 \text{ nF},$$

Select:  $C_3 = 10 \text{ nF}$

$$C_2 = \frac{1}{2 \times \pi \times F_{P3} \times R_3}; C_2 = 148 \text{ pF},$$

Select:  $C_2 = 150 \text{ pF}$

Calculate  $R_4$ ,  $R_5$  and  $R_6$ :

$$R_4 = \frac{1}{2 \times \pi \times C_4 \times F_{P2}}; R_4 = 127.6 \text{ }\Omega,$$

Select  $R_4 = 130 \text{ }\Omega$

$$R_5 = \frac{1}{2 \times \pi \times C_4 \times F_{Z2}}; R_5 = 3.98 \text{ k}\Omega,$$

Select  $R_5 = 4.02 \text{ k}\Omega$

$$R_6 = \frac{V_{ref}}{V_o - V_{ref}} \times R_5; R_6 = 1.53 \text{ k}\Omega,$$

Select  $R_6 = 1.54 \text{ k}\Omega$

### Setting the Power Good Threshold

In this design IR3891, the PGood outer limits are set at 85% and 120% of VREF. PGood signal is asserted 1.3ms after Vsns voltage reaches  $0.85 \times 0.5V = 0.425V$ .

As long as the Vsns voltage is between the threshold range, Enable is high, and no fault happens, the PGood remains high.

The following formula can be used to set the PGood threshold.  $V_{out(PGood\_TH)}$  can be taken as 85% of  $V_{out}$ . Choose  $R_{sns11} = 1.54 \text{ k}\Omega$ .

$$R_{sns12} = \left( \frac{V_{out(PGood\_TH)}}{0.85 \times VREF} - 1 \right) \times R_{sns11} \quad (35)$$

$R_{sns12} = 4.00 \text{ k}\Omega$ , Select  $4.02 \text{ k}\Omega$ ,

OVP comparator also uses Vsns signal for Over-Voltage detection. With above values for  $R_{sns22}$  and  $R_{sns21}$ , OVP trip point ( $V_{out\_OVP}$ ) is

$$V_{out\_OVP} = V_{REF} \times 1.2 \times \frac{(R_{sns11} + R_{sns12})}{R_{sns11}} \quad (36)$$

$$V_{out\_OVP} = 2.17 \text{ V}$$

### Selecting Power Good Pull-Up Resistor

The PGood1 and PGood2 are open drain outputs and require pull up resistors to VCC. The value of the pull-up resistors should limit the current flowing into the each PGood pin to be less than 5mA. A typical value used is 49.9kΩ.

The specifications for the channel 2 design:

$$\begin{aligned} V_{in} &= 12\text{V} \\ V_o &= 1.2\text{V} \\ V_{ramp} &= 1.8\text{V} \text{ (This is a function of } V_{in}, \text{ pls. see feed forward section)} \\ V_{ref} &= 0.5\text{V} \\ L_o &= 1.5\mu\text{H} \\ C_o &= 4 \times 22\mu\text{F}, \text{ ESR} \approx 3\text{m}\Omega \text{ each} \end{aligned}$$

In the calculations, 10uF is used for the 22uF  $C_o$  capacitors due to the 1.2V bias and 600 kHz frequency.

These result to:

$$\begin{aligned} F_{LC} &= 20.5 \text{ kHz} \\ F_{ESR} &= 5.3 \text{ MHz} \\ F_s/2 &= 300 \text{ kHz} \end{aligned}$$

Select crossover frequency  $F_o = 100 \text{ kHz}$

Since  $F_{LC} < F_o < F_s/2 < F_{ESR}$ , Type III is selected to place the pole and zeros.

Detailed calculation of compensation Type III:

Desired Phase Margin  $\Theta = 70^\circ$

$$F_{Z2} = F_o \sqrt{\frac{1 - \sin \Theta}{1 + \sin \Theta}} = 17.6 \text{ kHz}$$

$$F_{P2} = F_o \sqrt{\frac{1 + \sin \Theta}{1 - \sin \Theta}} = 567.1 \text{ kHz}$$

Select:

$$F_{Z1} = 0.5 \times F_{Z2} = 8.8 \text{ kHz and}$$

$$F_{P3} = 0.5 \times F_s = 300 \text{ kHz}$$

Select  $C_4 = 2.2\text{nF}$ .

Calculate  $R_3$ ,  $C_3$  and  $C_2$ :

$$R_3 = \frac{2 \times \pi \times F_o \times L_o \times C_o \times V_{ramp}}{C_4 \times V_{in}}; R_3 = 2.57 \text{ k}\Omega,$$

Select:  $R_3 = 2.87 \text{ k}\Omega$

$$C_3 = \frac{1}{2 \times \pi \times F_{Z1} \times R_3}; C_3 = 7 \text{ nF},$$

$$\text{Select: } C_3 = 10 \text{ nF} \quad C_2 = \frac{1}{2 \times \pi \times F_{P3} \times R_3};$$

$$C_2 = 206 \text{ pF},$$

Select:  $C_2 = 150 \text{ pF}$

Calculate  $R_4$ ,  $R_5$  and  $R_6$ :

$$R_4 = \frac{1}{2 \times \pi \times C_4 \times F_{P2}}; R_4 = 127.6 \Omega,$$

Select  $R_4 = 130 \Omega$

$$R_5 = \frac{1}{2 \times \pi \times C_4 \times F_{Z2}}; R_5 = 3.98 \text{ k}\Omega,$$

Select  $R_5 = 4.02 \text{ k}\Omega$

$$R_6 = \frac{V_{ref}}{V_o - V_{ref}} \times R_5; R_6 = 2.84 \text{ k}\Omega,$$

Select  $R_6 = 2.87 \text{ k}\Omega$

### Setting the Power Good Threshold

Equation (35) shows how to set values for  $R_{sns12}$  and  $R_{sns11}$ . Use the same equation to determine  $R_{sns21}$  and  $R_{sns22}$  values, but substitute  $R_{sns22}$  for  $R_{sns12}$  and  $R_{sns21}$  for  $R_{sns11}$ .

Choose  $R_{sns21} = 2.87 \text{ k}\Omega$ .

$$R_{sns22} = \left( \frac{V_{out(PGood\_TH)}}{0.85 \times VREF} - 1 \right) \times R_{sns21} \quad (37)$$

$$R_{sns22} = 4.02 \text{ k}\Omega$$

The typical over-voltage threshold is calculated below for channel 2. With above values for  $R_{sns22}$  and  $R_{sns21}$ , OVP trip point ( $V_{out\_OVP}$ ) is

$$V_{out\_OVP} = VREF \times 1.2 \times \frac{(R_{sns21} + R_{sns22})}{R_{sns22}} \quad (38)$$

$$V_{out\_OVP} = 1.44 \text{ V}$$

# APPLICATION DIAGRAM

## INTERNALLY BIASED SINGLE RAIL

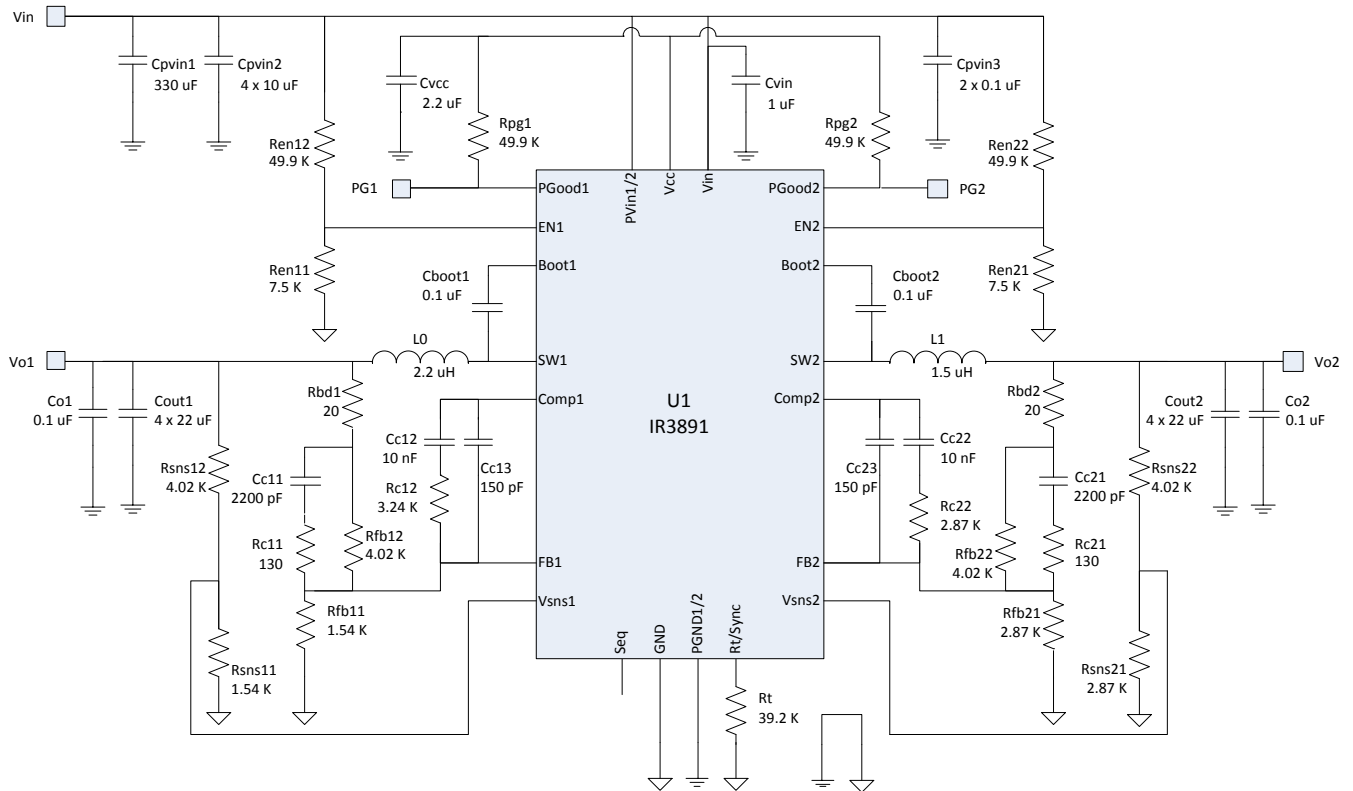

Figure 29: Application circuit for 12V to 1.8V and 1.2V, 4A Point of Load Converter Using the Internal LDO

Suggested Bill of Material for application circuit 12V to 1.8V and 1.2V

Part Reference	Qty	Value	Description	Manufacturer	Part Number
Cpvin1	1	330uF	SMD, electrolytic, 25V, 20%	Panasonic	EEV-FK1E331P
Cpvin2	4	10uF	1206, 25V, X5R, 10%	TDK	C3216X5R1E106M
Cvin	1	1.0uF	0603, 25V, X5R, 10%	Murata	GRM188R61E105KA12D
Cvcc	1	2.2uF	0603, 16V, X5R, 20%	TDK	C1608X5R1C225M
Co1 Co2 Cboot1 Cboot2 Cpvin3	6	0.1uF	0603, 25V, X7R, 10%	Murata	GRM188R71E104KA01D
Cc12 Cc22	2	10nF	0603, 50V, X7R, 10%	Murata	GRM188R71H103KA01D
Cc13 Cc23	2	150pF	0603, 50V, NPO, 5%	Murata	GRM1885C1H151JA01D
Cc11 Cc21	2	2200pF	0603, 50V, X7R, 10%	Murata	GRM188R71H222KA01D
Cpvin2	4	10uF	1206, 25V, X5R, 20%	TDK	C3216X5R1E106M
Cout1 Cout2	8	22uF	0805, 6.3V X5R, 20%	TDK	C2012X5R0J226M
L0	1	2.2uH	SMD 7.05x6.6x4.8mm, 11.2mΩ	Cyntec	PCMB065T-2R2MS
L1	1	1.5uH	SMD 7.05x6.6x4.8mm, 6.0mΩ	Cyntec	PCMB065T-1R5MS
Rbd1 Rbd2	2	20	Thick Film, 0603, 1/10W, 1%	Panasonic	ERJ-3EKF20R0V
Ren12 Ren22 Rpg1 Rpg2	4	49.9K	Thick Film, 0603, 1/10W, 1%	Panasonic	ERJ-3EKF4992V
Ren11 Ren21	2	7.5K	Thick Film, 0603, 1/10W, 1%	Panasonic	ERJ-3EKF7501V
Rc11 Rc21	2	130	Thick Film, 0603, 1/10W, 1%	Panasonic	ERJ-3EKF1300V
Rc12	1	3.24K	Thick Film, 0603, 1/10W, 1%	Panasonic	ERJ-3EKF3241V
Rc22	1	2.87K	Thick Film, 0603, 1/10W, 1%	Panasonic	ERJ-3EKF2871V
Rfb11 Rsns11	2	1.54K	Thick Film, 0603, 1/10W, 1%	Panasonic	ERJ-3EKF1541V
Rfb12 Rsns12 Rfb22 Rsns22	2	4.02K	Thick Film, 0603, 1/10W, 1%	Panasonic	ERJ-3EKF4021V
Rfb21 Rsns21	2	2.87K	Thick Film, 0603, 1/10W, 1%	Panasonic	ERJ-3EKF2871V
Rt	1	39.2K	Thick Film, 0603, 1/10W, 1%	Panasonic	ERJ-3EKF3922V
U1	1	IR3891	PQFN 5x6mm	International Rectifier	IR3891MPBF

## EXTERNALLY BIASED DUAL RAIL

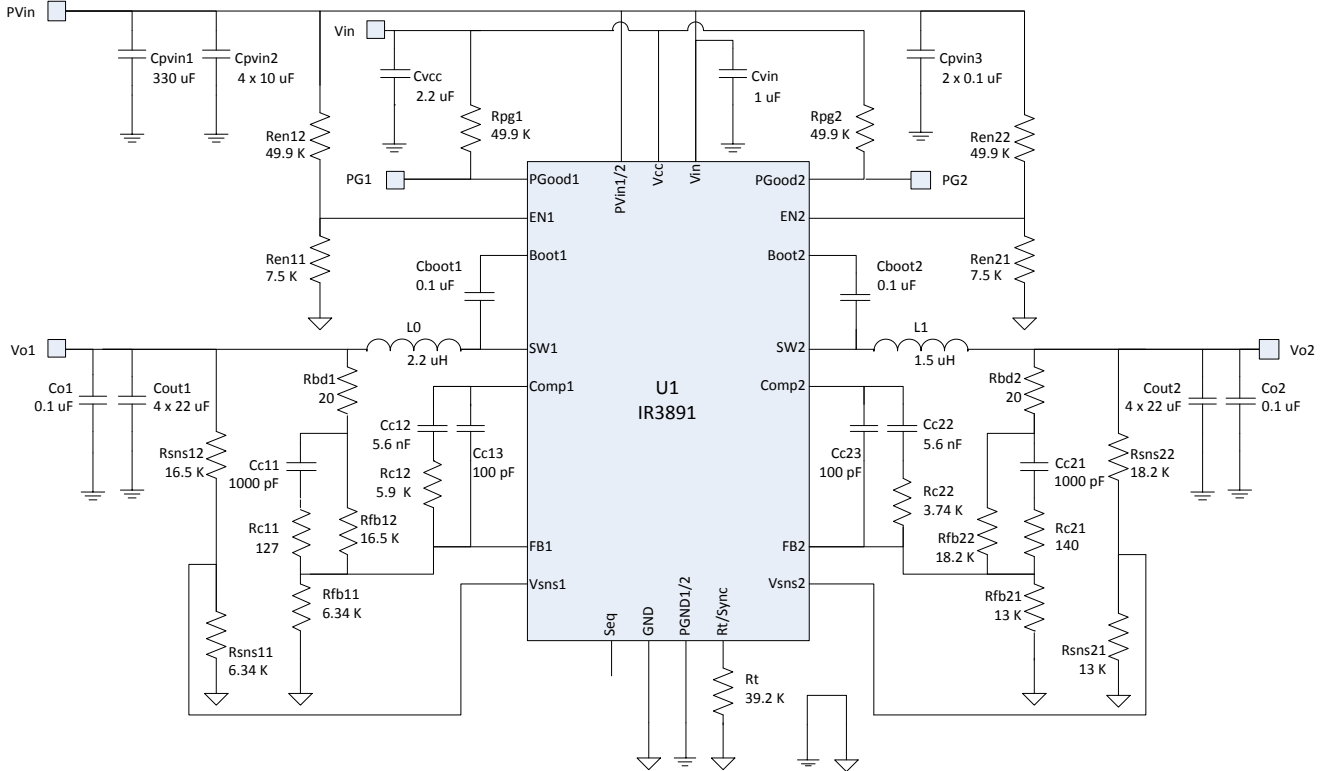

Figure 30: Application circuit for a 12V to 1.8V and 1.2V, 4A Point of Load Converter using external 5V VCC

Suggested Bill of Material for application circuit 12V to 1.8V and 1.2V using external 5V VCC

Part Reference	Qty	Value	Description	Manufacturer	Part Number
Cpvin1	1	330uF	SMD, electrolytic, 25V, 20%	Panasonic	EEV-FK1E331P
Cpvin2	4	10uF	1206, 25V, X5R, 10%	TDK	C3216X5R1E106M
Cvin	1	1.0uF	0603, 25V, X5R, 10%	Murata	GRM188R61E105KA12D
Cvcc	1	2.2uF	0603, 16V, X5R, 20%	TDK	C1608X5R1C225M
Cpvin3 Cboot1 Cboot2 Co1 Co2	6	0.1uF	0603, 25V, X7R, 10%	Murata	GRM188R71E104KA01D
Cc11 Cc21	2	1000pF	0603, 50V, X7R, 10%	Murata	GRM188R71H102KA01D
Cc12 Cc22	2	5.6nF	0603, 50V, X7R, 10%	Murata	GRM188R71H562KA01D
Cc13 Cc23	2	100pF	0603, 50V, NPO, 5%	Murata	GRM1885C1H101JA01D
Cout1 Cout2	8	22uF	0805, 6.3V X5R, 20%	TDK	C2012X5R0J226M
L0	1	2.2uH	SMD 7.05x6.6x4.8mm, 11.2mΩ	Cyntec	PCMB065T-2R2MS
L1	1	1.5uH	SMD 7.05x6.6x4.8mm, 6.0mΩ	Cyntec	PCMB065T-1R5MS
Rbd1 Rbd2	2	20	Thick Film, 0603, 1/10W, 1%	Panasonic	ERJ-3EKF20R0V
Rc11	1	127	Thick Film, 0603, 1/10W, 1%	Panasonic	ERJ-3EKF1270V
Rc12	1	5.9K	Thick Film, 0603, 1/10W, 1%	Panasonic	ERJ-3EKF5901V
Rc21	1	140	Thick Film, 0603, 1/10W, 1%	Panasonic	ERJ-3EKF1400V
Rc22	1	3.74K	Thick Film, 0603, 1/10W, 1%	Panasonic	ERJ-3EKF3741V
Ren11 Ren21	2	7.5K	Thick Film, 0603, 1/10W, 1%	Panasonic	ERJ-3EKF7501V
Ren12 Ren22 Rpg1 Rpg2	4	49.9K	Thick Film, 0603, 1/10W, 1%	Panasonic	ERJ-3EKF4992V
Rfb11 Rsns11	2	6.34K	Thick Film, 0603, 1/10W, 1%	Panasonic	ERJ-3EKF6341V
Rfb12 Rsns12	2	16.5K	Thick Film, 0603, 1/10W, 1%	Panasonic	ERJ-3EKF1652V
Rfb21 Rsns21	2	13K	Thick Film, 0603, 1/10W, 1%	Panasonic	ERJ-3EKF1302V
Rfb22 Rsns22	2	18.2K	Thick Film, 0603, 1/10W, 1%	Panasonic	ERJ-3EKF1822V
Rt	1	39.2K	Thick Film, 0603, 1/10W, 1%	Panasonic	ERJ-3EKF3922V
U1	1	IR3891	PQFN 5x6mm	International Rectifier	IR3891MPBF

## EXTERNALLY BIASED SINGLE RAIL

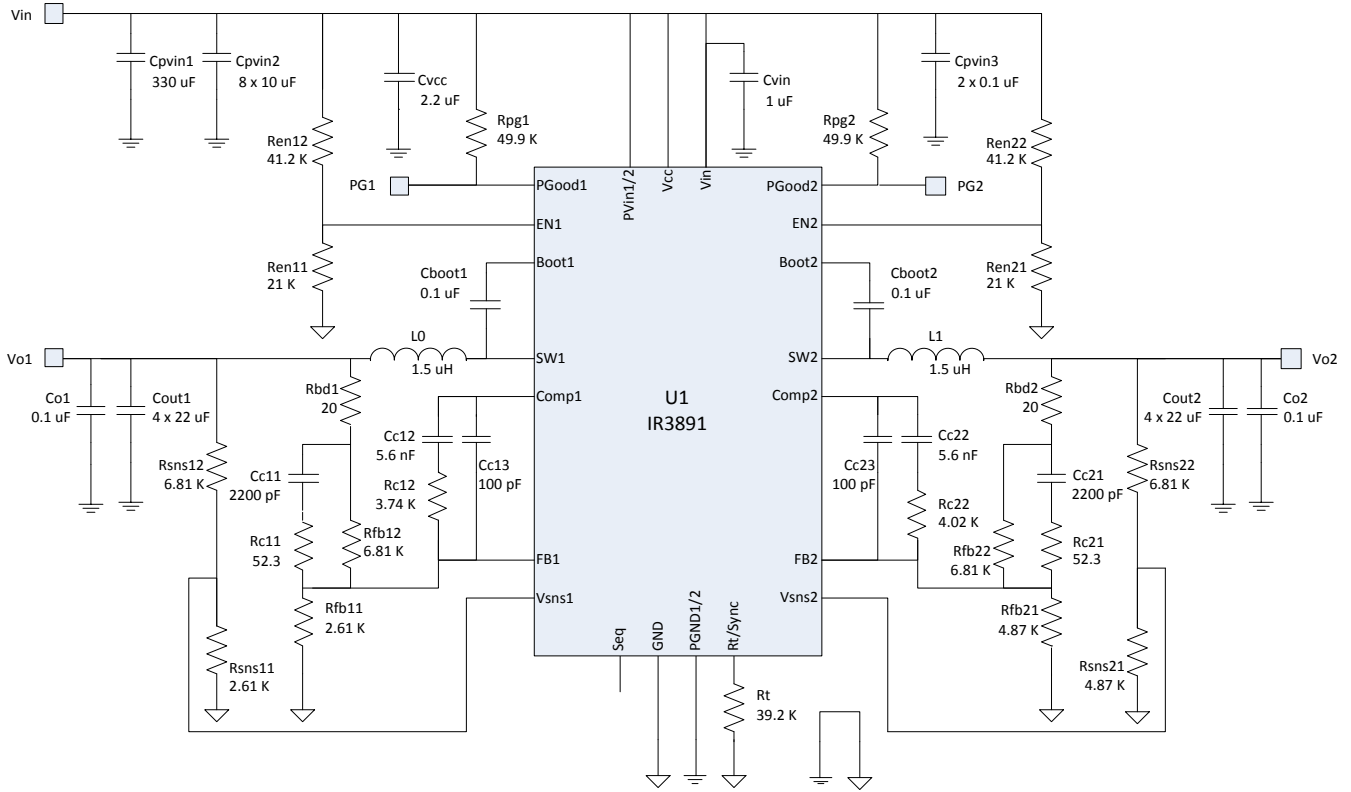

Figure 31: Application circuit for a 5V to 1.8V and 1.2V, 4A Point of Load Converter

Suggested bill of material for application circuit 5V to 1.8V and 1.2V

Part Reference	Qty	Value	Description	Manufacturer	Part Number
Cpvin1	1	330uF	SMD, electrolytic, 25V, 20%	Panasonic	EEV-FK1E331P
Cpvin2	8	10uF	1206, 25V, X5R, 10%	TDK	C3216X5R1E106M
Cvin	1	1.0uF	0603, 25V, X5R, 10%	Murata	GRM188R61E105KA12D
Cvcc	1	2.2uF	0603, 16V, X5R, 20%	TDK	C1608X5R1C225M
Cpvin3 Cboot1 Cboot2 Co1 Co2	6	0.1uF	0603, 25V, X7R, 10%	Murata	GRM188R71E104KA01D
Cc12 Cc22	2	5.6nF	0603, 50V, X7R, 10%	Murata	GRM188R71H562KA01D
Cc13 Cc23	2	100pF	0603, 50V, NPO, 5%	Murata	GRM1885C1H101JA01D
Cc11 Cc21	2	2200pF	0603, 50V, X7R, 10%	Murata	GRM188R71H222KA01D
Cout1 Cout2	8	22uF	0805, 6.3V X5R, 20%	TDK	C2012X5R0J226M
L0 L1	2	1.5uH	SMD 7.05x6.6x4.8mm, 6.0mΩ	Cyntec	PCMB065T-1R5MS
Rbd1 Rbd2	2	20	Thick Film, 0603, 1/10W, 1%	Panasonic	ERJ-3EKF20R0V
Rc11 Rc21	2	52.3	Thick Film, 0603, 1/10W, 1%	Panasonic	ERJ-3EKF52R3V
Rc12	1	6.81K	Thick Film, 0603, 1/10W, 1%	Panasonic	ERJ-3EKF6811V
Rc22	1	4.02K	Thick Film, 0603, 1/10W, 1%	Panasonic	ERJ-3EKF4021V
Ren11 Ren21	2	21K	Thick Film, 0603, 1/10W, 1%	Panasonic	ERJ-3EKF2102V
Ren12 Ren22	2	41.2K	Thick Film, 0603, 1/10W, 1%	Panasonic	ERJ-3EKF4122V
Rfb11 Rsns11	2	2.61K	Thick Film, 0603, 1/10W, 1%	Panasonic	ERJ-3EKF2611V
Rfb12 Rsns12 Rfb22 Rsns22	4	6.81K	Thick Film, 0603, 1/10W, 1%	Panasonic	ERJ-3EKF6811V
Rfb21 Rsns21	2	4.87K	Thick Film, 0603, 1/10W, 1%	Panasonic	ERJ-3EKF4871V
Rpg1 Rpg2	2	49.9K	Thick Film, 0603, 1/10W, 1%	Panasonic	ERJ-3EKF4992V
Rt	1	39.2K	Thick Film, 0603, 1/10W, 1%	Panasonic	ERJ-3EKF3922V
U1	1	IR3891	PQFN 5x6mm	International Rectifier	IR3891MPBF

## TYPICAL OPERATING WAVEFORMS

$V_{in}=P_{Vin}=12V$ ,  $V_{o1}=1.8V$ ,  $I_{out1}=0-4A$ ,  $V_{o2}=1.2V$ ,  $I_{out2}=0-4A$ ,  $F_s=600kHz$ , Room Temperature, No air flow

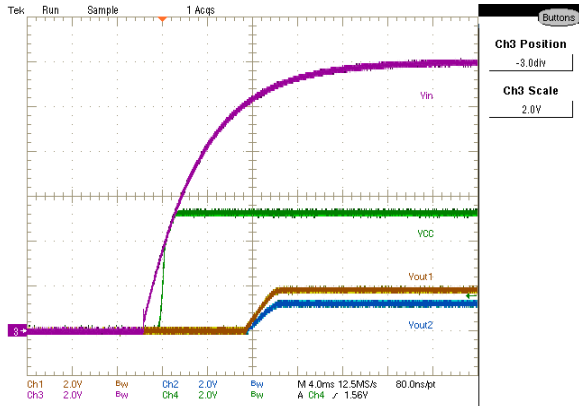

Figure 32: Startup with full load  
CH1:Vout1, Ch2:Vout2, Ch3:Vin, CH4:Vcc

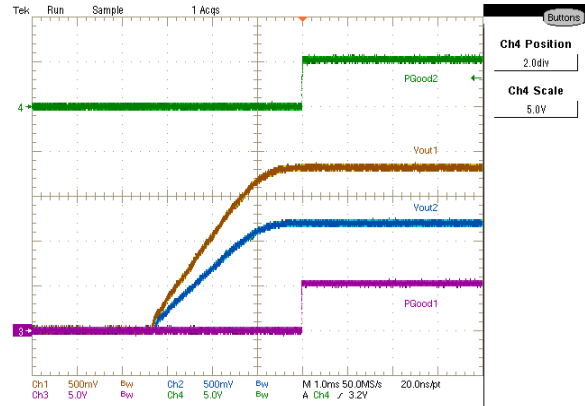

Figure 33: PGood signals at Startup with full load  
CH1:Vout1, Ch2:Vout2, Ch3:PGood1, CH4:PGood2

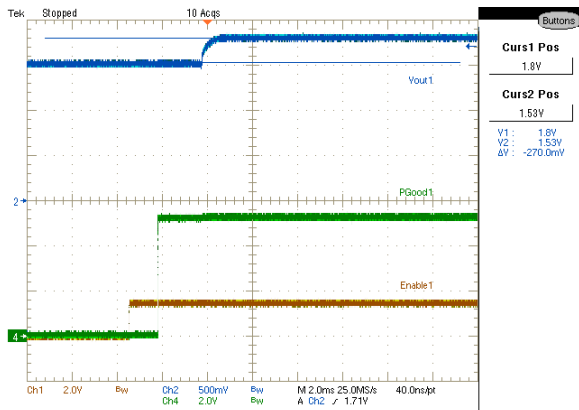

Figure 34: Channel 1 Startup with Pre-Bias, 1.52V  
CH1:Enable1, Ch2:Vout1, Ch4:PGood1

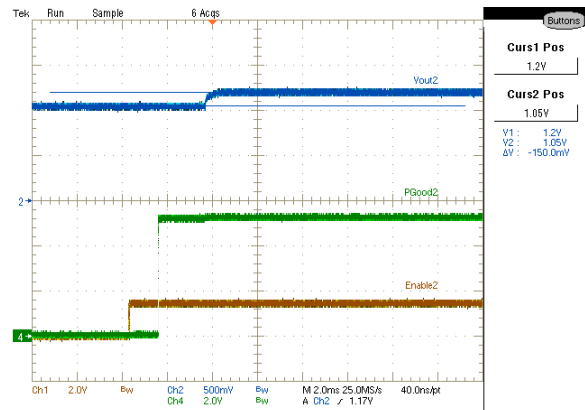

Figure 35: Channel 2 Startup with Pre-Bias, 1.05V  
CH1:Enable2, Ch2:Vout2, Ch4:PGood2

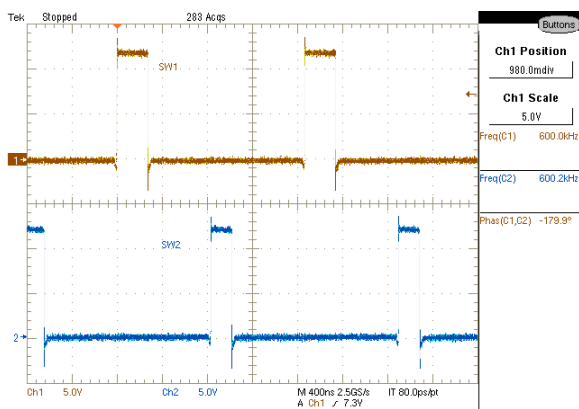

Figure 36: Inductor Switch Nodes at full load  
CH1:SW1, Ch2:SW2

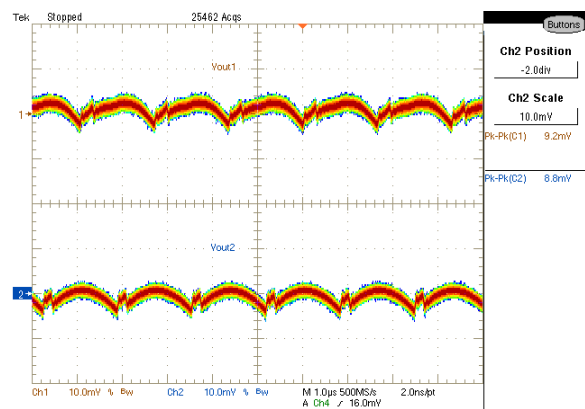

Figure 37: Output Voltage Ripples at full load  
CH1:Vout1, Ch2:Vout2

## TYPICAL OPERATING WAVEFORMS

$V_{in}=P_{Vin}=12V$ ,  $V_{o1}=1.8V$ ,  $I_{out1}=0-4A$ ,  $V_{o2}=1.2V$ ,  $I_{out2}=0-4A$ ,  $F_s=600kHz$ , Room Temperature, No air flow

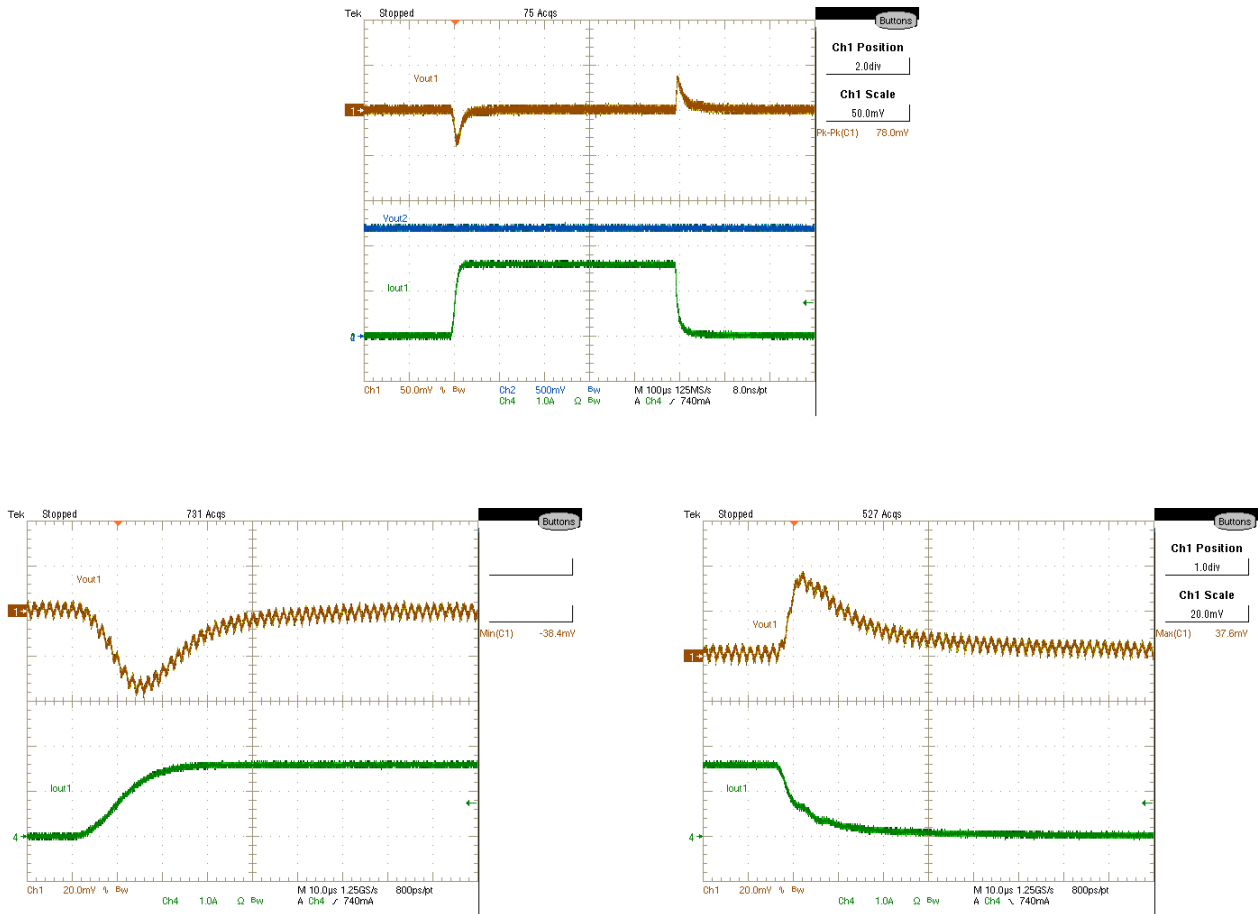

Figure 38: Vout1 Transient Response, 0A to 1.6A step at 2.5A/ $\mu$ Sec  
 CH1:Vout1, CH2=Vout2, CH4:Iout1

## TYPICAL OPERATING WAVEFORMS

$V_{in}=P_{Vin}=12V$ ,  $V_{o1}=1.8V$ ,  $I_{out1}=0-4A$ ,  $V_{o2}=1.2V$ ,  $I_{out2}=0-4A$ ,  $F_s=600kHz$ , Room Temperature, No air flow

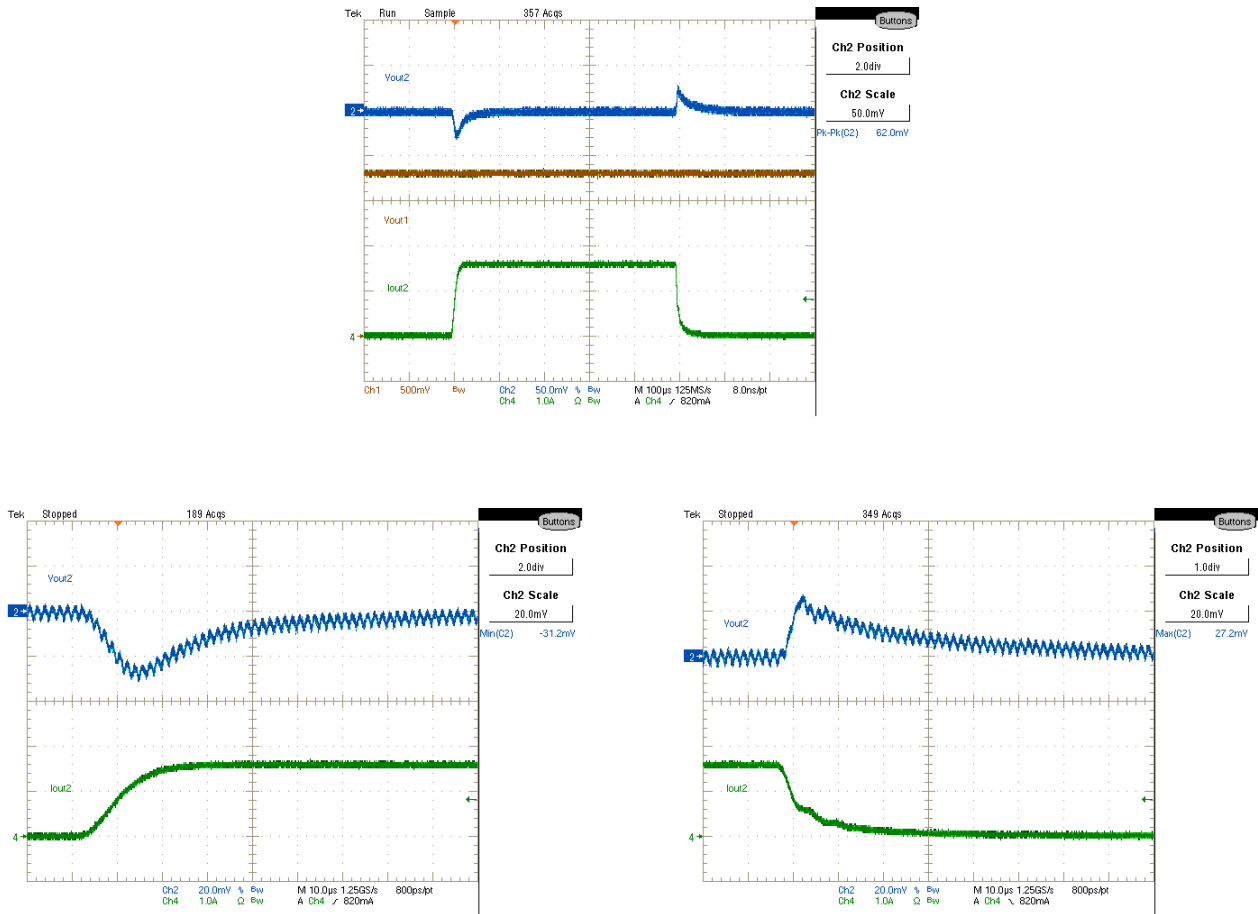

Figure 39: Vout2 Transient Response, 0A to 1.6A step at 2.5A/μSec  
 CH1:Vout1, CH2=Vout2, CH4:Iout2

## TYPICAL OPERATING WAVEFORMS

Vin=PVin=12V, Vo1=1.8V, Iout1=0-4A, Vo2=1.2V, Iout1=0-4A, Fs=600kHz, Room Temperature, No air flow

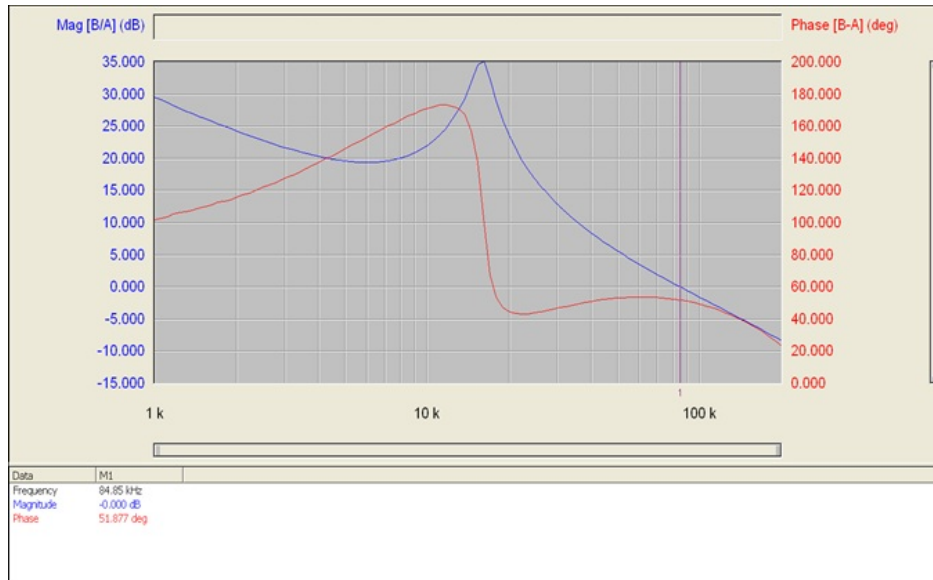

Figure 40: CH1 Bode Plot with 4A load, CH2 disabled.  
Fo = 84.9 kHz, Phase Margin = 51.9 Degrees

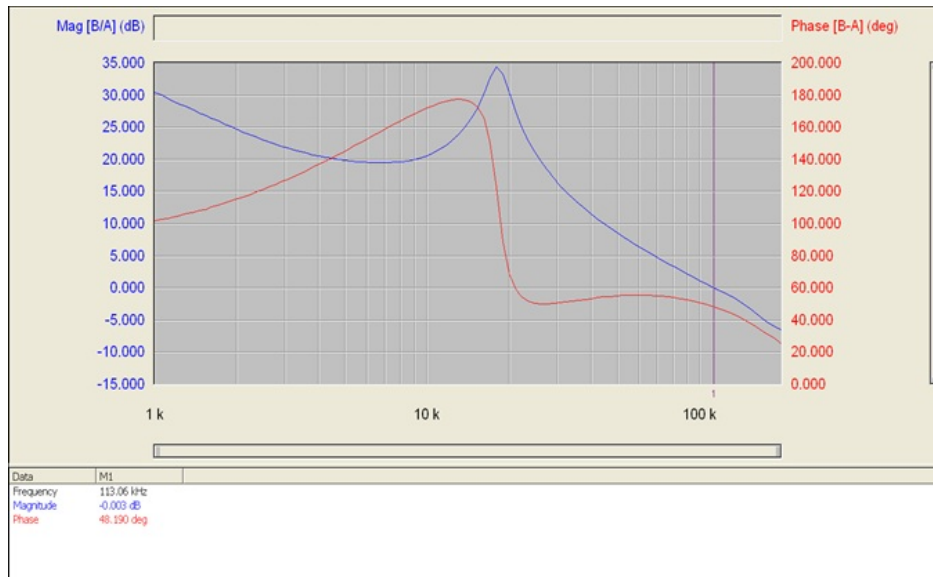

Figure 41: CH2 Bode Plot with 4A load, CH1 disabled.  
Fo = 113.1 kHz, Phase Margin = 48.2 Degrees

## LAYOUT RECOMMENDATIONS

The layout is very important when designing high frequency switching converters. Layout will affect noise pickup and can cause a good design to perform with less than expected results.

Make the connections for the power components on the top layer with wide, copper filled areas or polygons. In general, it is desirable to make proper use of power planes and polygons for power distribution and heat dissipation.

The inductor, input capacitors, output capacitors and the IR3891 should be as close to each other as possible. This helps to reduce the EMI radiated by the power traces due to the high switching currents through them. Place the input capacitor directly at the PVin pin of IR3891.

The feedback part of the system should be kept away from the inductor and other noise sources.

The critical bypass components such as capacitors for PVin and VCC should be close to their respective

pins. It is important to place the feedback components including feedback resistors and compensation components close to Fb and Comp pins.

In a multilayer PCB use one layer as a power ground plane and have a control circuit ground (analog ground), to which all signals are referenced. The goal is to localize the high current path to a separate loop that does not interfere with the more sensitive analog control function. These two grounds must be connected together on the PC board layout at a single point. It is recommended to place all the compensation parts over the analog ground plane on top layer.

The Power QFN is a thermally enhanced package. Based on thermal performance it is recommended to use at least a 4-layers PCB. To effectively remove heat from the device the exposed pad should be connected to the ground plane using vias. Figure 42a-d illustrates the implementation of the layout guidelines outlined above, on the IRDC3891 4-layer demo board.

- Ground path length between VIN- and VOUT1- should be minimized with maximum copper
- Compensation parts should be placed as close as possible to the Comp pins
- Single point connection between AGND & PGND, should be placed near the part and kept away from noise sources
- Ground path length between VIN- and VOUT2- should be minimized with maximum copper

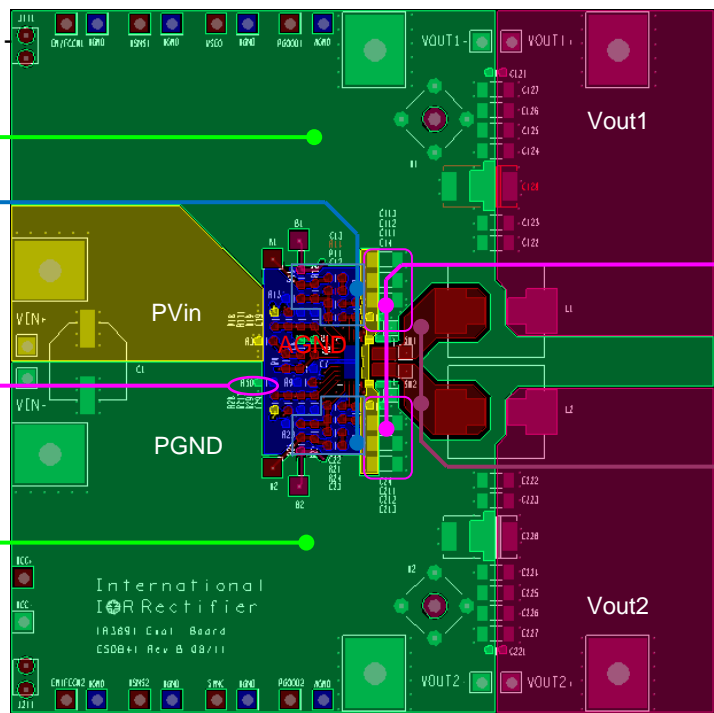

- Bypass caps should be placed as close as possible to their
- SW node copper is kept only at the top layer to minimize the switching noise

Figure 42a: IRDC3891 Demo board Layout Considerations – Top Layer

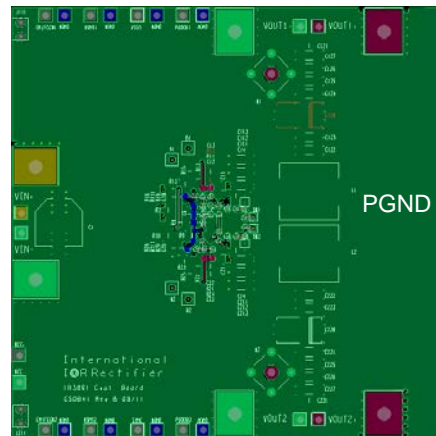
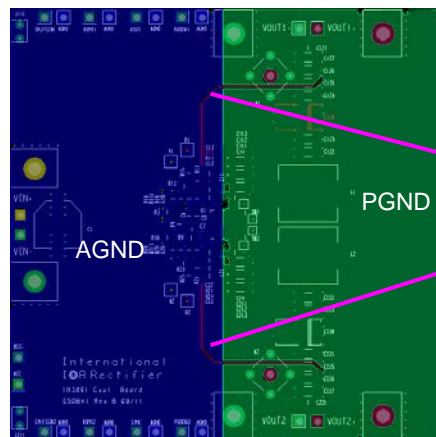

Figure 42b: IRDC3891 Demo board Layout Considerations – Bottom Layer



Feedback and Vsns trace routing should be kept away from noise sources

Figure 42c: IRDC3891 Demo board Layout Considerations – Mid Layer 1

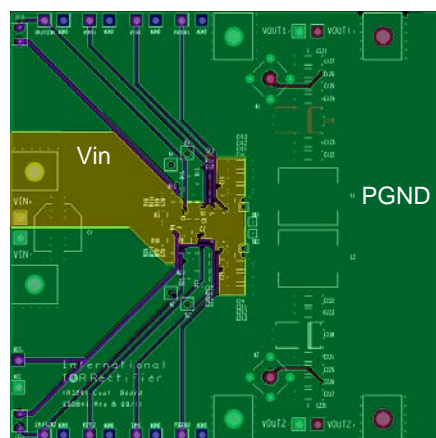

Figure 42d: IRDC3891 Demo board Layout Considerations – Mid Layer 2

## PCB METAL AND COMPONENT PLACEMENT

Evaluations have shown that the best overall performance is achieved using the substrate/PCB layout as shown in following figures. PQFN devices should be placed to an accuracy of 0.050mm on both X and Y axes. Self-centering behavior is highly dependent on solders and processes, and

experiments should be run to confirm the limits of self-centering on specific processes. For further information, please refer to “SupIRBuck® Multi-Chip Module (MCM) Power Quad Flat No-Lead (PQFN) Board Mounting Application Note.” **(AN1132)**

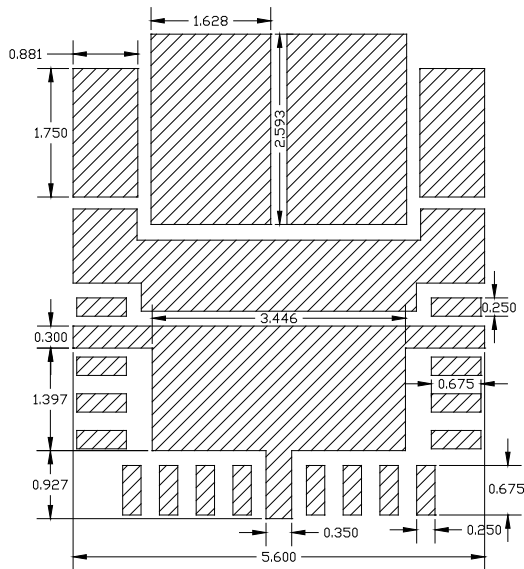

Figure 43: PCB Pad Sizes Detail 1  
(Dimensions in mm)

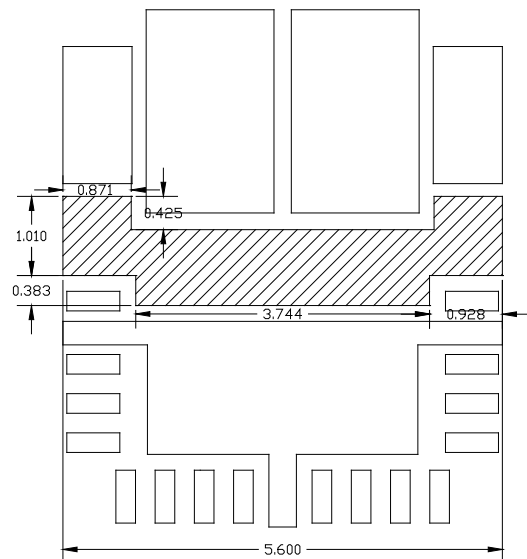

Figure 44: PCB Pad Sizes Detail 2  
(Dimensions in mm)

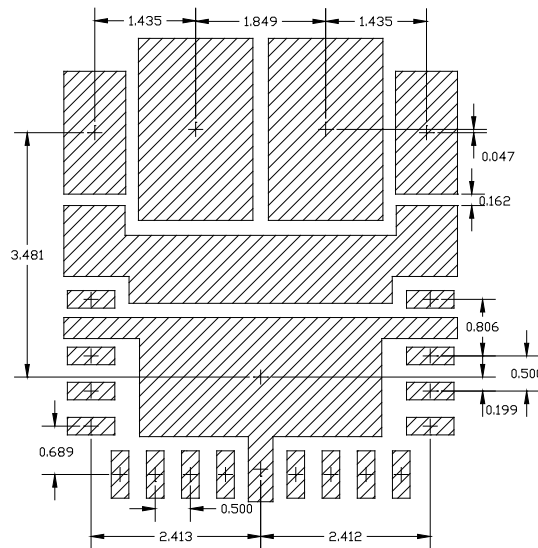

Figure 45: PCB Metal Pad Spacing (Dimensions in mm)

## SOLDER RESIST

- IR recommends that the larger Power or Land Area pads are Solder Mask Defined (SMD). This allows the underlying Copper traces to be as large as possible, which helps in terms of current carrying capability and device cooling capability.
- When using SMD pads, the underlying copper traces should be at least 0.05mm larger (on each edge) than the Solder Mask window, in order to accommodate any layer to layer misalignment. (i.e. 0.1mm in X & Y).
- However, for the smaller Signal type leads around the edge of the device, IR recommends that these are Non Solder Mask Defined or Copper Defined.
- When using NSMD pads, the Solder Resist Window should be larger than the Copper Pad by at least 0.025mm on each edge, (i.e. 0.05mm in X & Y), in order to accommodate any layer to layer misalignment.
- Ensure that the solder resist in-between the smaller signal lead areas are at least 0.15mm wide, due to the high x/y aspect ratio of the solder mask strip.

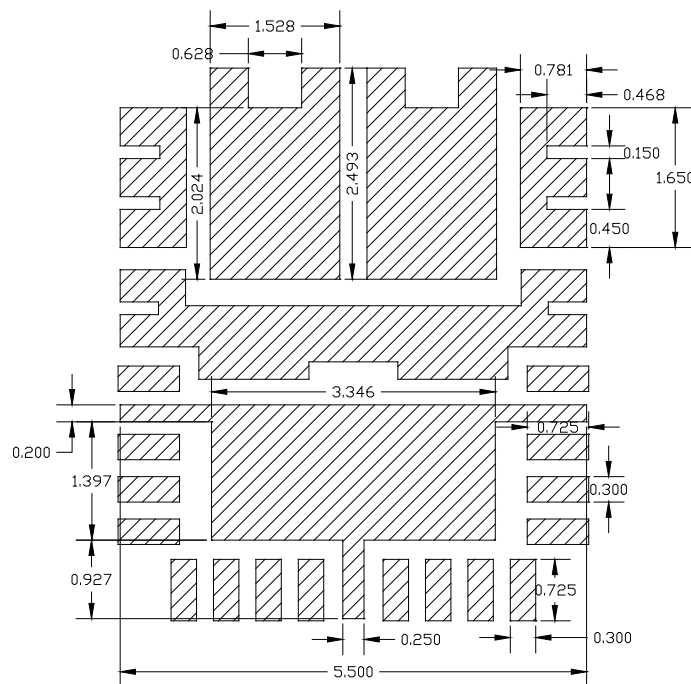

Figure 46: SMD Pad Sizes Detail 1 (Dimensions in mm)

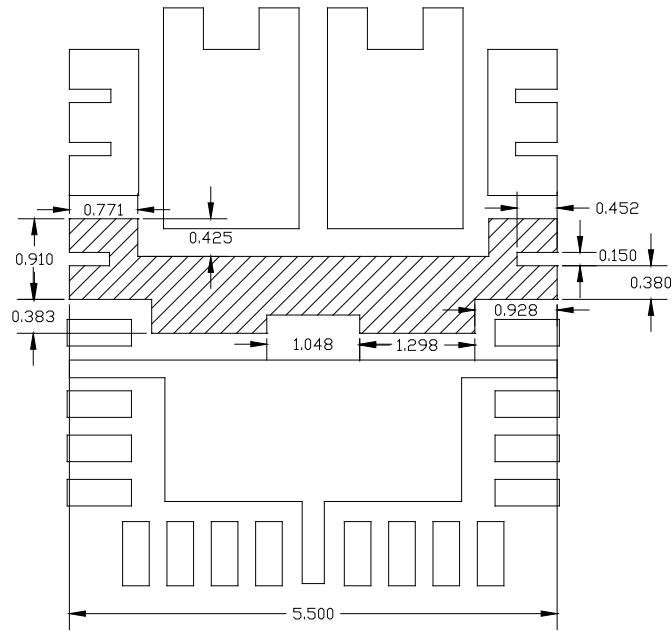

Figure 47: SMD Pad Sizes Detail 2 (Dimensions in mm)

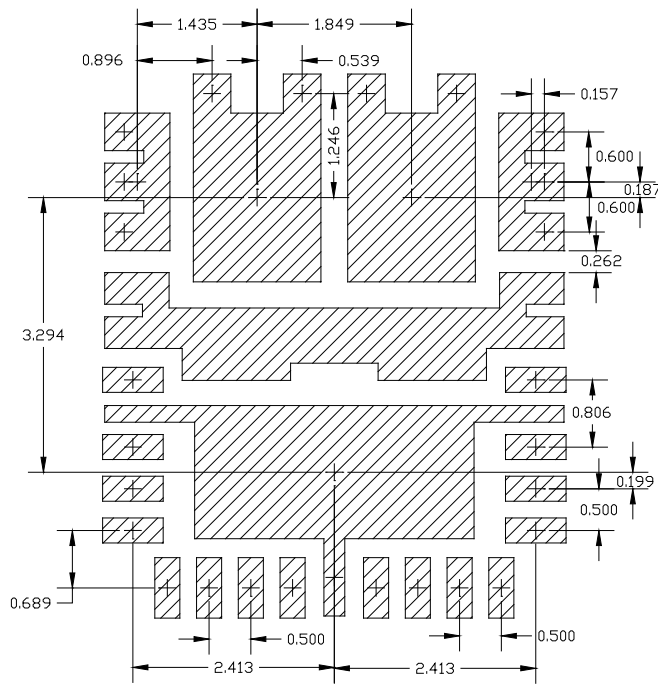

Figure 48: SMD Pad Spacing (Dimensions in mm)

## STENCIL DESIGN

- Stencils for PQFN can be used with thicknesses of 0.100-0.250mm (0.004-0.010"). Stencils thinner than 0.100mm are unsuitable because they deposit insufficient solder paste to make good solder joints with the ground pad; high reductions sometimes create similar problems. Stencils in the range of 0.125mm-0.200mm (0.005-0.008"), with suitable reductions, give the best results.
- Evaluations have shown that the best overall performance is achieved using the stencil design shown in following figure. This design is for a stencil thickness of 0.127mm (0.005"). The reduction should be adjusted for stencils of other thicknesses.

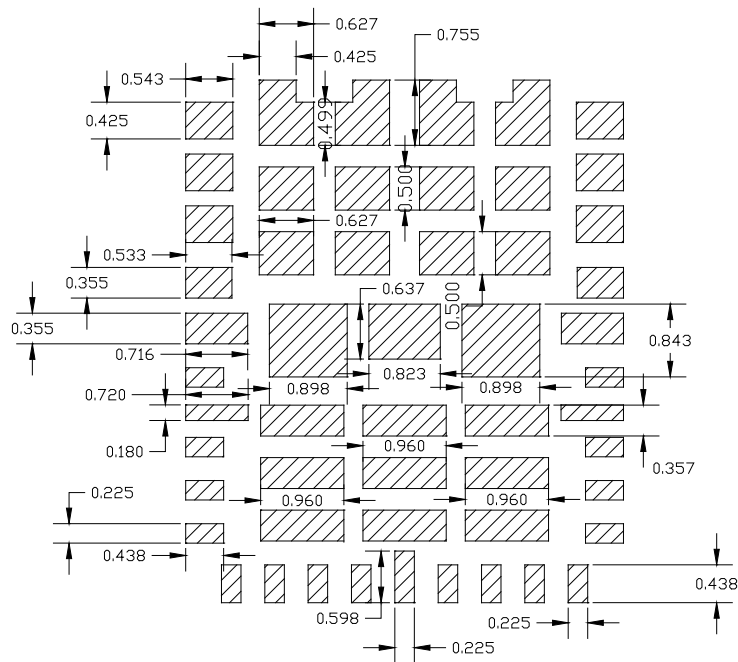

Figure 49: Stencil Pad Sizes (Dimensions in mm)

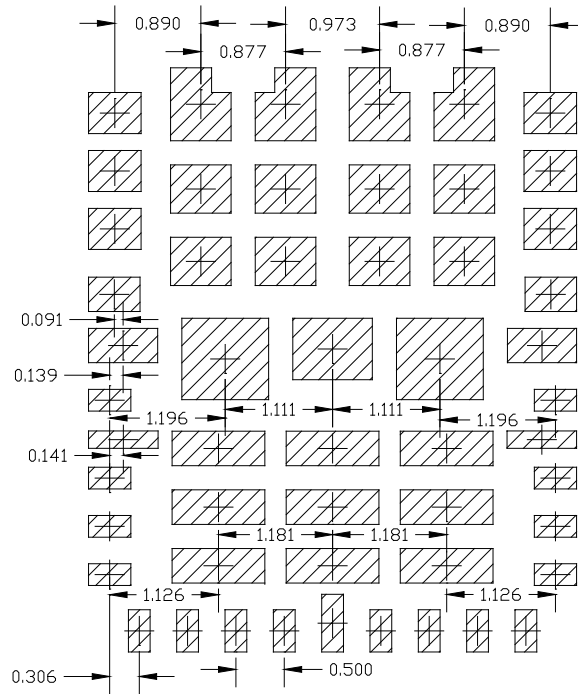

Figure 50: Stencil Pad Spacing Detail 1 (Dimensions in mm)

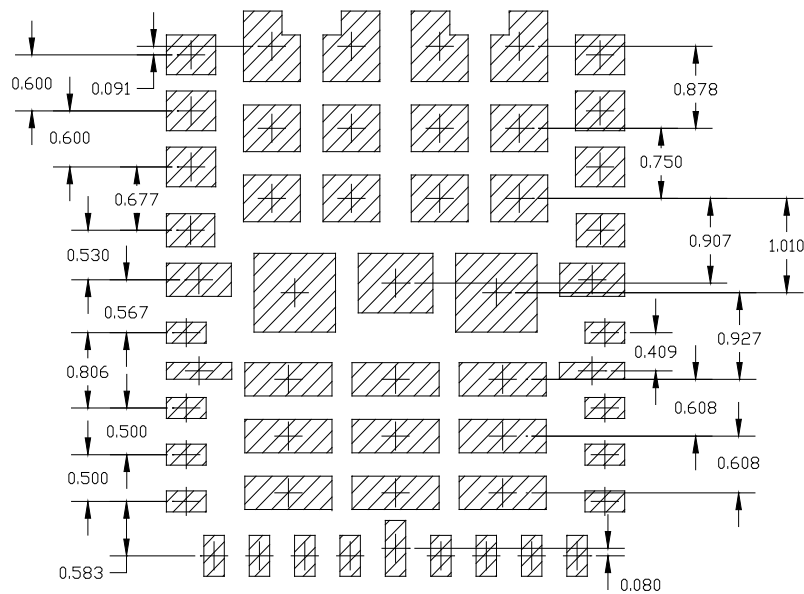

Figure 51: Stencil Pad Spacing Detail 2 (Dimensions in mm)

## MARKING INFORMATION

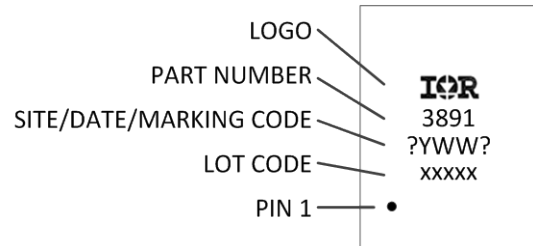
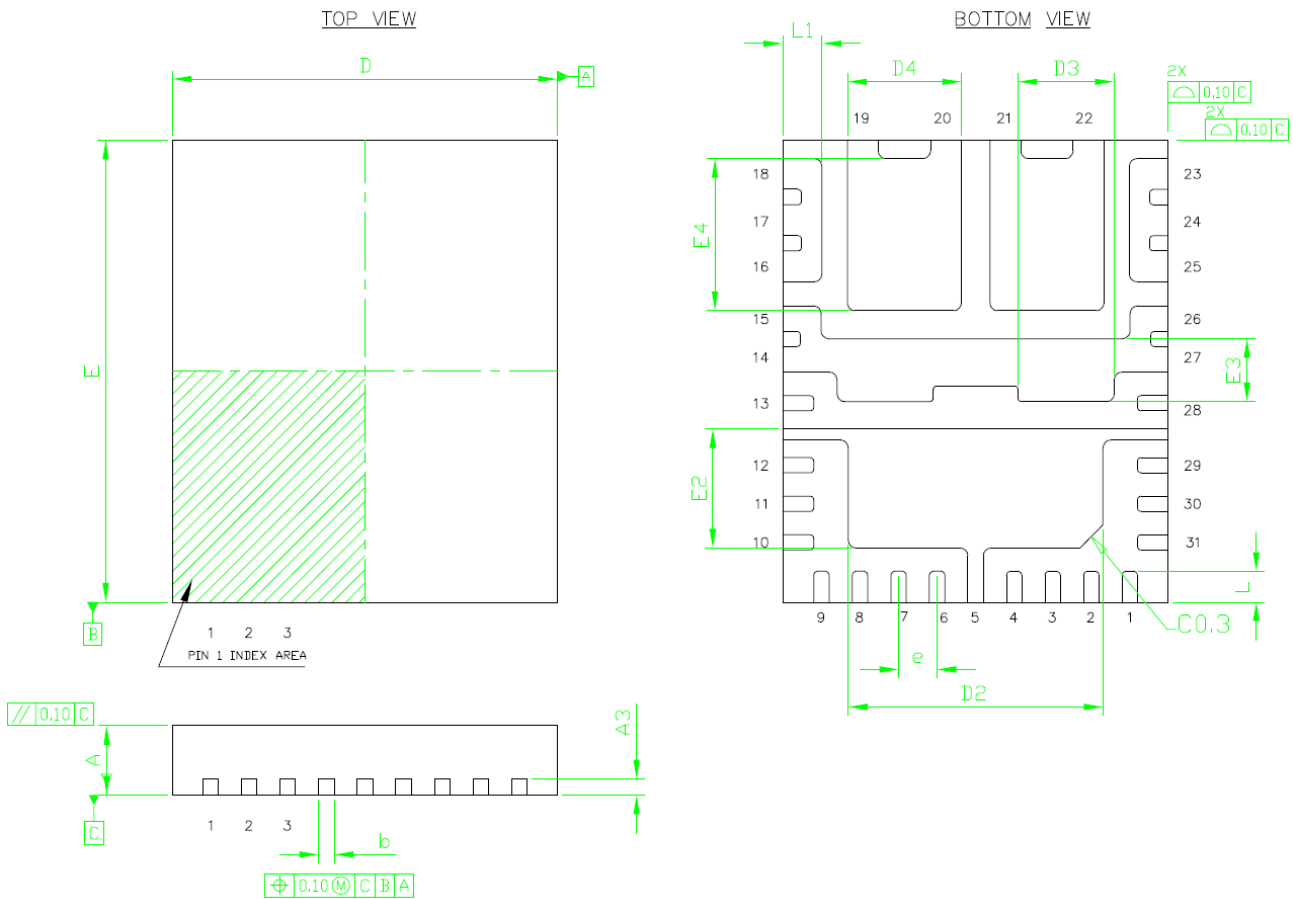

Figure 52: Marking Information

SYMBOL	Common					
	DIMENSIONS MILLIMETER			DIMENSIONS INCH		
	MIN.	NOM.	MAX.	MIN.	NOM.	MAX.
A	0.85	0.90	0.95	0.034	0.036	0.038
A3	0.203 REF.			0.008 REF.		
b	0.15	0.20	0.25	0.006	0.008	0.010
D	4.90	5.00	5.10	0.193	0.197	0.201
E	5.90	6.00	6.10	0.233	0.237	0.241
D2	3.26	3.31	3.36	0.129	0.131	0.133
E2	1.50	1.55	1.60	0.060	0.062	0.063
D3	1.20	1.25	1.30	0.048	0.050	0.052
E3	0.77	0.82	0.87	0.031	0.033	0.035
D4	1.43	1.48	1.53	0.057	0.059	0.061
E4	1.92	1.97	2.02	0.076	0.078	0.080
e	0.50 BSC			0.020 BSC		
L	0.35	0.40	0.45	0.014	0.016	0.018
L1	0.46	0.51	0.56	0.019	0.021	0.023

**NOTES :**

1. DIMENSION AND TOLERANCING CONFORM TO ASME Y14.5M-1994.
2. CONTROLLING DIMENSIONS : MILLIMETER. CONVERTED INCH DIMENSION ARE NOT NECESSARILY EXACT.

**ENVIRONMENTAL QUALIFICATIONS**

<b>Qualification Level</b>		Industrial	
<b>Moisture Sensitivity Level</b>		5mm x 6mm PQFN	MSL2
<b>ESD</b>	Machine Model (JESD22-A115A)	Class A	
		<200V	
	Human Body Model (JESD22-A114F)	Class 1C	
		≥1000V to <2000V	
Charged Device Model (JESD22-C101D)	Class III		
	≥500V to ≤1000V		
<b>RoHS Compliant</b>		Yes	

Data and specifications subject to change without notice.  
 Qualification Standards can be found on IR's Web site.

International  
 Rectifier

**IR WORLD HEADQUARTERS:** 233 Kansas St., El Segundo, California 90245, USA Tel: (310) 252-7105  
 TAC Fax: (310) 252-7903

Visit us at [www.irf.com](http://www.irf.com) for sales contact information.  
[www.irf.com](http://www.irf.com)

## Looking for pricing, stock, or lifecycle information?

Click below to explore more details on WIN SOURCE:

 [View IRDC3891 on WIN SOURCE](#)

 [Infineon Technologies](#) Information

## Optimize Your Supply Chain with WIN SOURCE Solutions

-  Global Sourcing Solution
-  Obsolete Management
-  Cost Control Management
-  Shortage Management
-  Alternative Solution
-  Excess Inventory Management