

Features

- High Dynamic Range for AM and FM
- Integrated AGC for AM and FM
- High Intercept Point 3rd Order for FM
- FM Amplifier Adjustable to Various Cable Impedances
- High Intercept Point 2nd and 3rd Order for AM
- Low Noise Output Voltage
- Low Power Consumption
- Low Output Impedance AM

1. Description

The ATR4251 is an integrated low-noise AM/FM antenna amplifier with integrated AGC in BiCMOS2S technology. The device is designed in particular for car applications, and is suitable for windshield and roof antennas.

Figure 1-1. Block Diagram QFN24 Package

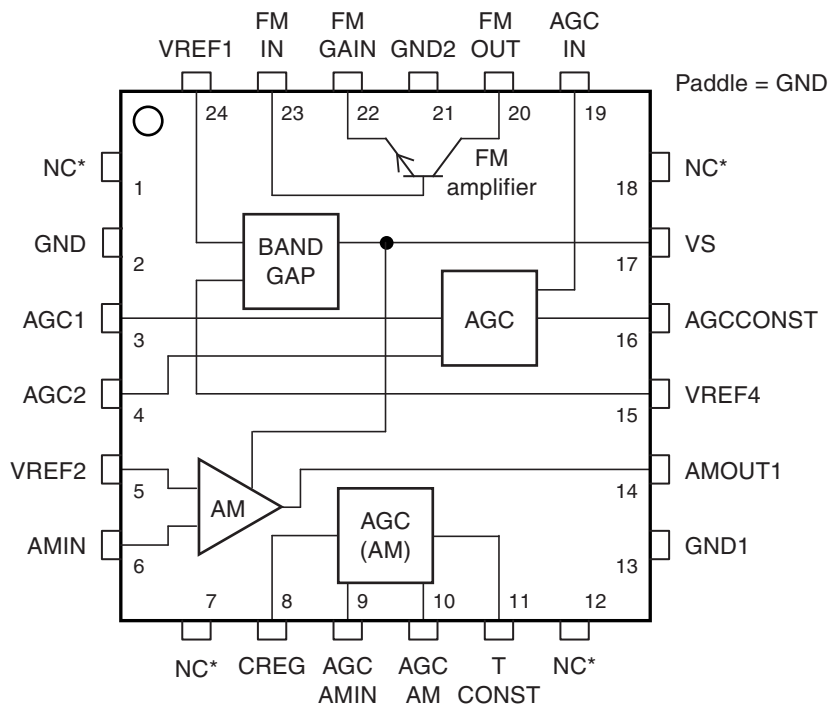

* Pin must not be connected to any other pin or supply chain except GND.



Low-noise, High-dynamic- range AM/FM Antenna Amplifier IC

ATR4251



Figure 1-2. Block Diagram SSO20 Package

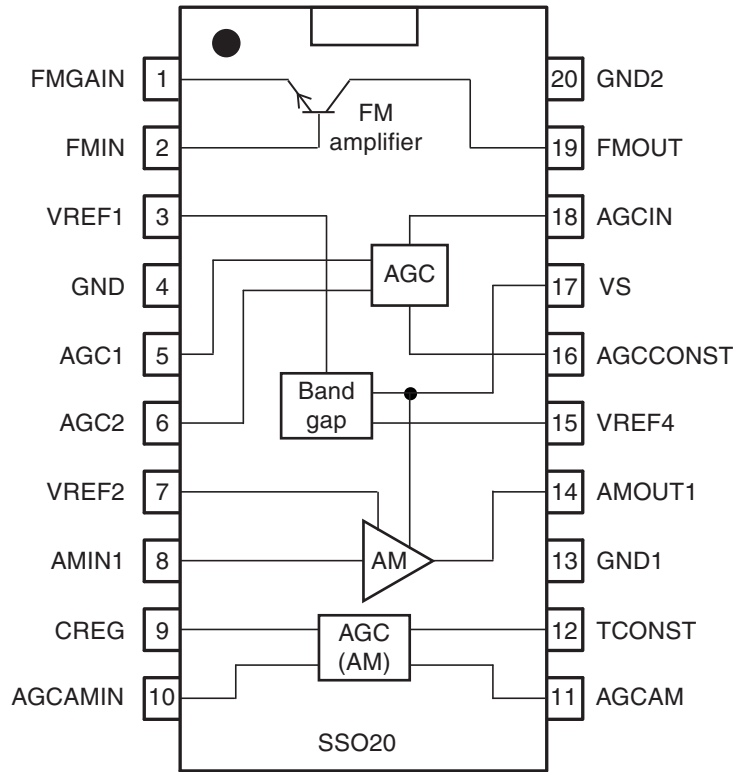

2. Pin Configuration

Figure 2-1. Pinning QFN24

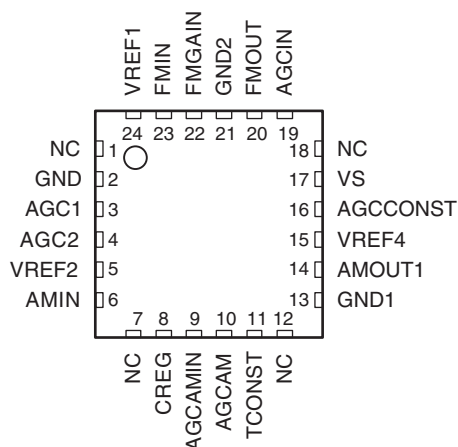

Table 2-1. Pin Description QFN24

Pin	Symbol	Function
1	NC	Pin must not be connected to any other pin or supply chain except GND.
2	GND	Ground FM
3	AGC1	AGC output for pin diode
4	AGC2	AGC output for pin diode
5	VREF2	Reference voltage for pin diode
6	AMIN	AM input, impedance matching
7	NC	Pin must not be connected to any other pin or supply chain except GND.
8	CREG	AM - AGC time constant capacitance 2
9	AGCAMIN	AM - AGC input
10	AGCAM	AM - AGC output for pin diode
11	TCONST	AM - AGC - time constant capacitance 1
12	NC	Pin must not be connected to any other pin or supply chain except GND.
13	GND1	Ground AM
14	AMOUT1	AM output, impedance matching
15	VREF4	Bandgap
16	AGCCONST	FM AGC time constant
17	VS	Supply voltage
18	NC	Pin must not be connected to any other pin or supply chain except GND.
19	AGCIN	FM AGC input
20	FMOUT	FM output
21	GND2	Ground
22	FMGAIN	FM gain adjustment
23	FMIN	FM input
24	VREF1	Reference voltage 2.7V
Paddle	GND	Ground Paddle

Figure 2-2. Pinning SSO20

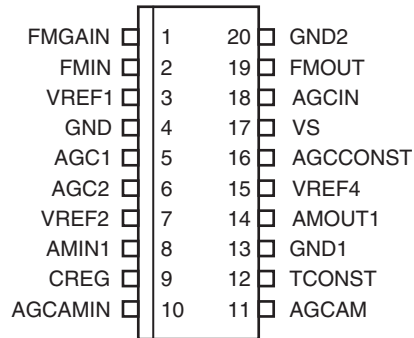

Table 2-2. Pin Description SSO20

Pin	Symbol	Function
1	FMGAIN	FM gain adjustment
2	FMIN	FM input
3	VREF1	Reference voltage 2.7V
4	GND	FM ground
5	AGC1	AGC output for PIN diode
6	AGC2	AGC output for PIN diode
7	VREF2	Reference voltage for PIN diode
8	AMIN1	AM input, impedance matching
9	CREG	AM AGC constant capacitance 2
10	AGCAMIN	AM input, AM AGC
11	AGCAM	AM AGC output for PIN diode
12	TCONST	AM AGC constant capacitance 1
13	GND1	AM ground
14	AMOUT1	AM output, impedance matching
15	VREF4	Band gap 6V
16	AGCCONST	FM AGC constant
17	VS	Supply voltage
18	AGCIN	FM AGC input
19	FMOUT	FM output
20	GND2	FM ground

3. Functional Description

The ATR4251 is an integrated AM/FM antenna impedance matching circuit. It compensates cable losses between the antenna (for example windshield, roof, or bumper antennas) and the car radio which is usually placed far away from the antenna.

AM refers to the long wave (LW), medium wave (MW) and short wave (SW) frequency bands (150 kHz to 30 MHz) that are usually used for AM transmission, and FM means any of the frequency bands used world-wide for FM radio broadcast (70 MHz to 110 MHz).

Two separate amplifiers are used for AM and FM due to the different operating frequencies and requirements in the AM and FM band. This allows the use of separate antennas (for example, windshield antennas) for AM and FM. Of course, both amplifiers can also be connected to one antenna (for example, the roof antenna).

Both amplifiers have automatic gain control (AGC) circuits in order to avoid overdriving the amplifiers under large-signal conditions. The two separate AGC circuits prevent strong AM signals from blocking FM stations, and vice versa.

3.1 AM Amplifier

Due to the long wavelength in AM bands, the antennas used for AM reception in automotive applications must be short compared to the wavelength. Therefore these antennas do not provide 50Ω output impedance, but have an output impedance of some pF. If these (passive) antennas are connected to the car radio by a long cable, the capacitive load of this cable (some 100 pF) dramatically reduces the signal level at the tuner input.

In order to overcome this problem, ATR4251 provides an AM buffer amplifier with low input capacitance (less than 2.5 pF) and low output impedance (5Ω). The low input capacitance of the amplifier reduces the capacitive load at the antenna, and the low impedance output driver is able to drive the capacitive load of the cable. The voltage gain of the amplifier is close to 1 (0 dB), but the insertion gain that is achieved when the buffer amplifier is inserted between antenna output and cable may be much higher (35 dB). The actual value depends, of course, on antenna and cable impedance.

The input of the amplifier is connected by an external $4.7\text{ M}\Omega$ resistor to the bias voltage (pin 7, SSO20) in order to achieve high input impedance and low noise voltage.

AM tuners in car radios usually use PIN diode attenuators at their input. These PIN diode attenuators attenuate the signal by reducing the input impedance of the tuner. Therefore, a series resistor is used at the AM amplifier output in the standard application. This series resistor guarantees a well-defined source impedance for the radio tuner and protects the output of the AM amplifier from short circuit by the PIN diode attenuator in the car radio.

3.2 AM AGC

The IC is equipped with an AM AGC capability to prevent overdriving of the amplifier in case the amplifier operates near strong antenna signal level, for example, transmitters.

The AM amplifier output AMOUT1 is applied to a resistive voltage divider. This divided signal is applied to the AGC level detector input pin AGCAMIN. The rectified signal is compared against an internal reference. The threshold of the AGC can be adjusted by adjusting the divider ratio of the external voltage divider. If the threshold is reached, pin AGCAM opens an external transistor which controls PIN diode currents and limits the antenna signal and thereby prevents overdriving the AM amplifier IC.

3.3 FM Amplifier

The FM amplifier is realized with a single NPN transistor. This allows use of an amplifier configuration optimized on the requirements. For low-cost applications, the common emitter configuration provides good performance at reasonable bills of materials (BOM) cost⁽¹⁾. For high-end applications, common base configuration with lossless transformer feedback provides a high IP3 and a low noise figure at reasonable current consumption⁽²⁾. In both configurations, gain, input, and output impedance can be adjusted by modification of external components.

The temperature compensated bias voltage (VREF1) for the base of the NPN transistor is derived from an integrated band gap reference. The bias current of the FM amplifier is defined by an external resistor.

- Notes:
1. See test circuit ([Figure 8-1 on page 11](#))
 2. See application circuit ([Figure 9-1 on page 12](#))

3.4 FM/TV AGC

The IC is equipped with an AGC capability to prevent overdriving the amplifier in cases when the amplifier is operated with strong antenna signals (for example, near transmitters).

It is possible to realize an external TV antenna amplifier with integrated AGC and external RF transistor. The bandwidth of the integrated AGC circuit is 900 MHz.

FM amplifier output FMOUT is connected to a capacitive voltage divider and the divided signal is applied to the AGC level detector at pin AGCIN. This level detector input is optimized for low distortion. The rectified signal is compared against an internal reference. The threshold of the AGC can be adjusted by adjusting the divider ratio of the external voltage divider. If the threshold is reached, pin AGC1 opens an external transistor which controls the PIN diode current, this limits the amplifier input signal level and prevents overdriving the FM amplifier.

4. Absolute Maximum Ratings

Stresses beyond those listed under “Absolute Maximum Ratings” may cause permanent damage to the device. This is a stress rating only and functional operation of the device at these or any other conditions beyond those indicated in the operational sections of this specification is not implied. Exposure to absolute maximum rating conditions for extended periods may affect device reliability.

Reference point is ground (pins 4 and 13 for SSO20 and pins 2, 13, 21 and Paddle for QFN24 package).

Parameters	Symbol	Value	Unit
Supply voltage	V_S	12	V
Power dissipation, P_{tot} at $T_{amb} = 90^\circ\text{C}$	P_{tot}	550	mW
Junction temperature	T_j	150	$^\circ\text{C}$
Ambient temperature SSO20 package	T_{amb}	-40 to +90	$^\circ\text{C}$
Ambient temperature QFN24 package	T_{amb}	-40 to +105	$^\circ\text{C}$
Storage temperature	T_{stg}	-50 to +150	$^\circ\text{C}$
ESD HMB	All pins	± 2000	V
ESD MM	All pins	± 200	V

5. Thermal Resistance

Parameters	Symbol	Value	Unit
Junction ambient, soldered on PCB, dependent on PCB Layout for SSO 20 package	R_{thJA}	92	K/W
Junction ambient, soldered on PCB, dependent on PCB Layout for QFN package	R_{thJA}	40	K/W

6. Operating Range

Parameters	Symbol	Min.	Typ.	Max.	Unit
Supply voltage	V_S	8	10	11	V
Ambient temperature SSO20 package	T_{amb}	-40		+90	$^\circ\text{C}$
Ambient temperature QFN 24 package	T_{amb}	-40		+105	$^\circ\text{C}$

7. Electrical Characteristics

See Test Circuit, [Figure 8-1 on page 11](#); $V_S = 10V$, $T_{amb} = 25^\circ C$, unless otherwise specified. Pin numbers in () are referred to the QFN package.

No.	Parameters	Test Conditions	Pin	Symbol	Min.	Typ.	Max.	Unit	Type*
1.1	Supply currents		17 (17)	I_S	11	14	17	mA	A
1.2	Reference voltage 1 output	$I_{vref1} = 1 \text{ mA}$	3 (24)	V_{Ref1}	2.65	2.8	2.95	V	A
1.3	Reference voltage 2 output		7 (5)	V_{Ref2}	$0.38 V_S$	$0.4 V_S$	$0.42 V_S$	V	B
1.4	Reference voltage 4 output	$I_{vref4} = 3 \text{ mA}$	15 (15)	V_{Ref4}	6.0	6.25	6.5	V	A
2	AM Impedance Matching 150 kHz to 30 MHz (The Frequency Response from Pin 8 to Pin 14)								
2.1	Input capacitance	$f = 1 \text{ MHz}$	8 (6)	C_{AMIN}	2.2	2.45	2.7	pF	D
2.2	Input leakage current	$T_{amb} = 85^\circ C$	8 (6)				40	nA	C
2.3	Output resistance		14 (14)	R_{OUT}	4	5	8	Ω	D
2.4	Voltage gain	$f = 1 \text{ MHz}$	8/14 (6/14)	A	0.94	0.97	1		A
2.5	Output noise voltage (rms value)	Pin 14 (14), $R_{78} = 4.7 \text{ M}\Omega$, $B = 9 \text{ kHz}$, $C_{ANT} = 30 \text{ pF}$ 150 kHz 200 kHz 500 kHz 1 MHz	14	V_{N1} V_{N2} V_{N3} V_{N4}		-8 -9 -11 -12	-6 -7 -9 -10	$\text{dB}\mu\text{V}$ $\text{dB}\mu\text{V}$ $\text{dB}\mu\text{V}$ $\text{dB}\mu\text{V}$	C
2.6	2 nd harmonic	$V_S = 10V$, 50 Ω load, $f_{AMIN} = 1 \text{ MHz}$, input voltage = 120 $\text{dB}\mu\text{V}$	AMOUT1			-60	-58	dBc	C
2.7	3 rd harmonic	$V_S = 10V$, 50 Ω load, $f_{AMIN} = 1 \text{ MHz}$, input voltage = 120 $\text{dB}\mu\text{V}$	AMOUT1			-53	-50	dBc	C
3	AM AGC								
3.1	Input resistance		10 (9)	$R_{AGCAMIN}$	40	50		$\text{k}\Omega$	D
3.2	Input capacitance	$f = 1 \text{ MHz}$	10 (9)	$C_{AGCAMIN}$	2.6	3.2	3.8	pF	D
3.3	AGC input voltage threshold	$f = 1 \text{ MHz}$	10 (9)	V_{AMth}	75	77	79	$\text{dB}\mu\text{V}$	B
3.4	3 dB corner frequency	AGC threshold increased by 3 dB			10			MHz	D
3.5	Minimal AGCAM output voltage	$V_{iHF} = 90 \text{ dB}\mu\text{V}$ at pin 10 (9)	10/11 (9/10)	V_{AGC}	$V_S - 2.4$	$V_S - 2.1$	$V_S - 1.7$	V	A
3.6	Maximal AGCAM output voltage	$V_{iHF} = 0V$ at pin 10 (9)	10/11 (9/10)	V_{AGC}	$V_S - 0.2$	$V_S - 0.1$		V	A
3.7	Maximal AGCAM output voltage ⁽¹⁾	$V_{iHF} = 0V$ at pin 10 (9) $T = +85^\circ C$	10/11 (9/10)	V_{AGC}	$V_S - 0.4$	$V_S - 0.3$		V	C
3.8	Maximum AGC sink current	$V_{iHF} = 0V$ at pin 10 (9) U (pin 12 (11)) = 2V	12 (11)	I_{AMsink}	-150	-120	-90	μA	A

*) Type means: A = 100% tested, B = 100% correlation tested, C = Characterized on samples, D = Design parameter

- Notes:
1. Leakage current of PIN diode can be adjusted by an external resistor between pin 11 and V_S
 2. Demo board measurements (see [Figure 8-1 on page 11](#) "Common Emitter Configuration")
 3. Demo board measurements (see [Figure 9-1 on page 12](#) "Common Base Configuration")

7. Electrical Characteristics (Continued)

See Test Circuit, [Figure 8-1 on page 11](#); $V_S = 10V$, $T_{amb} = 25^\circ C$, unless otherwise specified. Pin numbers in () are referred to the QFN package.

No.	Parameters	Test Conditions	Pin	Symbol	Min.	Typ.	Max.	Unit	Type*
3.9	Transconductance of Level detector	$V_{IHF} = V_{AMth}$ at pin 10 (9)	10/12 (9/11)	$\frac{I_{AM \sin k}}{V_{AMth}}$		20		$\frac{\mu A}{mV_{rms}}$	C
3.10	IP3 at level detector input	Figure 9-2 on page 13 , 1 MHz and 1,1MHz, 120 dB μ V	10 (9)		150	170		dB μ V	D
3.11	PIN diode current generation	$d(20 \log I_{Pin-diode}) / dU_{Pin12}$ $T = 25^\circ C$, $U_{Pin12} = 2V$				30		dB/V	D
3.12	Output resistance		9 (8)	R_{OUT}	27	35	45	k Ω	D
4	FM Amplifier								
4.1	Emitter voltage		1 (22)		1.85	1.95	2.05	V	A
4.2	Emitter voltage	$T = -40^\circ C$ to $+85^\circ C$	1 (22)		1.8	2.0	2.2	V	C
4.3	Supply current limit	$R_E = 56\Omega$	19 (20)	I_{19}			37	mA	D
4.4	Maximum output voltage	$V_S = 10V$	19 (20)		12			V_{pp}	D
4.5	Input resistance	$f = 100$ MHz	2 (23)	R_{FMIN}		50		Ω	D
4.6	Output resistance	$f = 100$ MHz	19 (20)	R_{FMOUT}		50		Ω	D
4.7	Power gain ⁽²⁾	$f = 100$ MHz	FMOUT/ FMIN	G		5		dB	A
4.8	Output noise voltage (emitter circuit) ⁽²⁾	$f = 100$ MHz, B = 120 kHz	19 (20)	V_N		-5.1		dB μ V	D
4.9	OIP3 (emitter circuit) ⁽²⁾	$f = 98 + 99$ MHz	19 (20)	I_{IP3}		140		dB μ V	C
4.10	Gain ⁽³⁾					6		dB	C
4.11	Noise figure ⁽³⁾					2.8		dB	C
4.12	OIP3 ⁽³⁾	$f = 98 + 99$ MHz				148		dB μ V	C

Parameters Dependent of External Components in Application Circuit: R_{FMIN} , R_{FMOUT} , G, V_N , IIP3

5	FM AGC								
5.1	AGC threshold	$f = 100$ MHz $f = 900$ MHz	18 (19)	$V_{th1,100}$ $V_{th1,900}$	81 81	83 85	85 87	dB μ V dB μ V	B B
5.2	AGC1 output voltage	AGC1 active, $V_{pin16(16)} = 5V$	5 (24)	V_{AGC}	$V_S - 2.1V$	$V_S - 1.9V$	$V_S - 1.7V$	V	C
5.3	AGC1 output voltage	AGC1 inactive, $V_{pin16(16)} = 1.7V$	5 (24)	V_{AGC}	$V_S - 0.2V$	V_S		V	C
5.4	AGC2 output voltage	AGC2 active, $V_{pin16(16)} = 1.7V$	6 (4)	V_{AGC}	$V_S - 2.1V$	$V_S - 1.9V$	$V_S - 1.7V$	V	C
5.5	AGC2 output voltage	AGC2 inactive, $V_{pin16(16)} = 5V$	6 (4)	V_{AGC}	$V_S - 0.2V$	V_S		V	C
5.6	Input resistance		18 (19)	R_{Pin18}	17	21	25	k Ω	D

*) Type means: A = 100% tested, B = 100% correlation tested, C = Characterized on samples, D = Design parameter

- Notes:
1. Leakage current of PIN diode can be adjusted by an external resistor between pin 11 and V_S
 2. Demo board measurements (see [Figure 8-1 on page 11](#) "Common Emitter Configuration")
 3. Demo board measurements (see [Figure 9-1 on page 12](#) "Common Base Configuration")





7. Electrical Characteristics (Continued)

See Test Circuit, [Figure 8-1 on page 11](#); $V_S = 10V$, $T_{amb} = 25^\circ C$, unless otherwise specified. Pin numbers in () are referred to the QFN package.

No.	Parameters	Test Conditions	Pin	Symbol	Min.	Typ.	Max.	Unit	Type*
5.7	Input capacitance	$F = 100 \text{ MHz}$	18 (19)	C_{Pin18}	1.5	1.75	1.9	pF	D
5.8	IP3 at AGC input	Figure 9-2 on page 13 , 100 MHz and 105 MHz, $V_{Gen} = 120 \text{ dB}\mu V$	18 (19)			150		dB μV	D
5.9	IP3 at AGC input	900 MHz and 920 MHz $V_{Gen} = 120 \text{ dB}\mu V$	18 (19)			148		dB μV	D
5.10	Max. AGC sink current	$V_{iHF} = 0V$	16	I_{Pin16}	-11	-9	-7	μA	C
5.11	Transconductance	$V_{iHF} = V_{th1,100}$, $dI_{Pin16(16)} / dU_{Pin18(19)}$		dI_{Pin16} / dU_{Pin18}	0.8	1.0	1.3	mA/V (rms)	C
5.12	Gain AGC1, AGC2	$U_{Pin16} = 3V$, $dU_{Pin5(3)} / dU_{Pin16(16)}$, $-dU_{Pin6(4)} / dU_{Pin16(16)}$			0.5	0.56	0.6		C

*) Type means: A = 100% tested, B = 100% correlation tested, C = Characterized on samples, D = Design parameter

- Notes:
1. Leakage current of PIN diode can be adjusted by an external resistor between pin 11 and VS
 2. Demo board measurements (see [Figure 8-1 on page 11](#) "Common Emitter Configuration")
 3. Demo board measurements (see [Figure 9-1 on page 12](#) "Common Base Configuration")

8. Test Circuit FM/AM

Figure 8-1. Common Emitter Configuration

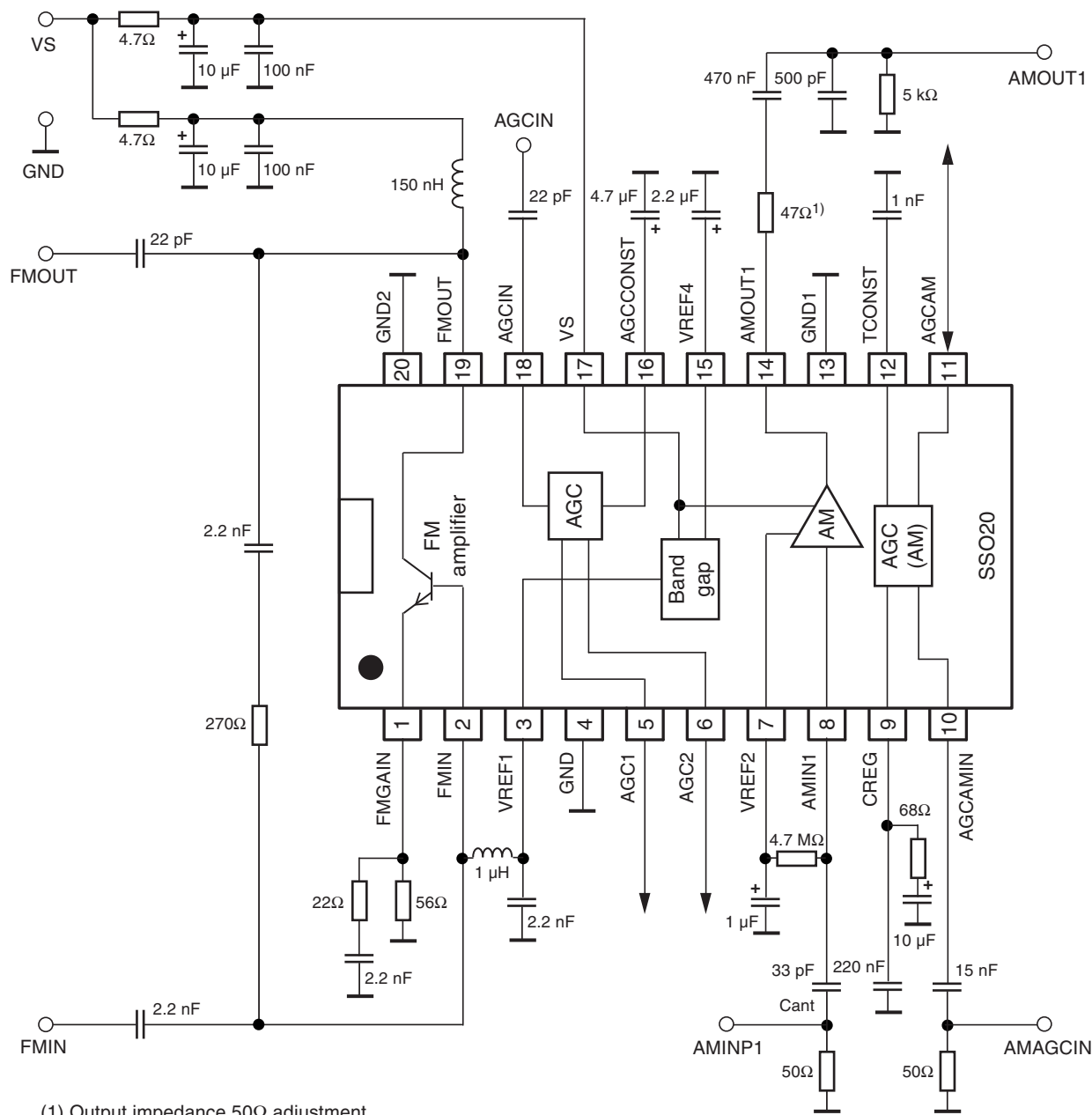

(1) Output impedance 50Ω adjustment

9. Application Circuit (Demo Board)

Figure 9-1. Common Base Configuration

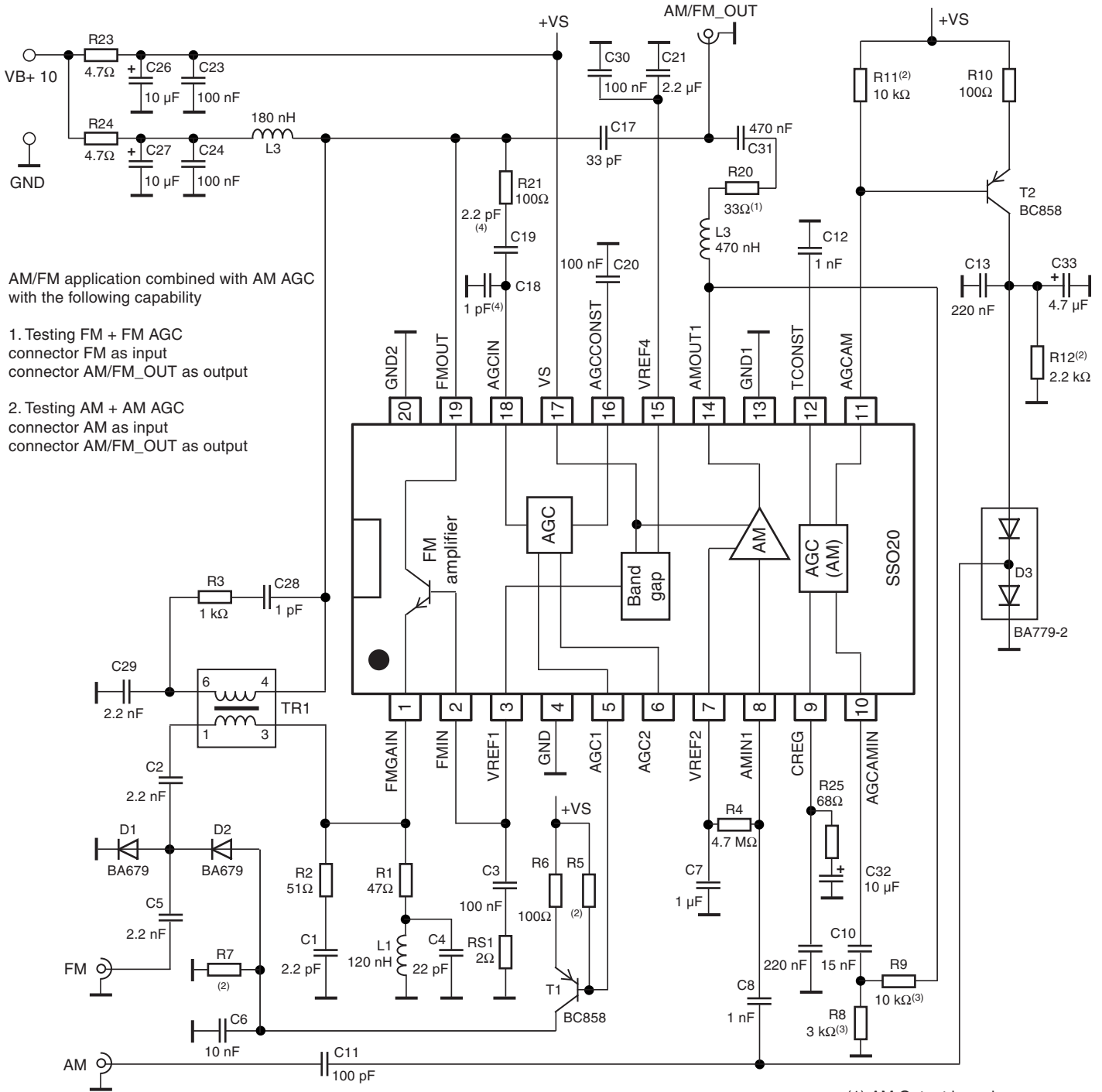

AM/FM application combined with AM AGC with the following capability

1. Testing FM + FM AGC
connector FM as input
connector AM/FM_OUT as output
2. Testing AM + AM AGC
connector AM as input
connector AM/FM_OUT as output

- (1) AM Output impedance (50Ω adjustment)
- (2) Leakage current reduction
- (3) AM AGC threshold
- (4) AM AGC threshold

Figure 9-2. Antenna Dummy for Test Purposes

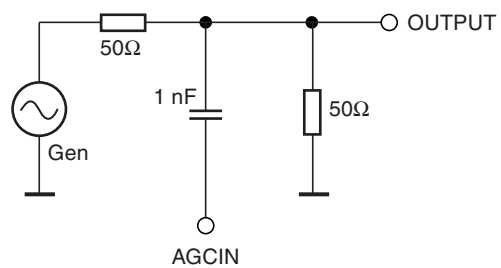

10. Internal Circuitry

Table 10-1. Equivalent Pin Circuits (ESD Protection Circuits Not Shown)

PIN SSO20	PIN QFN24	Symbol	Equivalent Circuit
1 2 19	22 23 20	FMGAIN FMIN FMOUT	
3	24	VREF1	
4, 13, 20	2, 13, 21	GND	
5 6	3 4	AGC1 AGC2	
	1, 7, 12, 18	NC	
7	5	VREF2	

Table 10-1. Equivalent Pin Circuits (ESD Protection Circuits Not Shown) (Continued)

PIN SSO20	PIN QFN24	Symbol	Equivalent Circuit
8	6	AMIN1	
9	8	CREG	
10	9	AGCAMIN	
11	10	AGCAM	

Table 10-1. Equivalent Pin Circuits (ESD Protection Circuits Not Shown) (Continued)

PIN SSO20	PIN QFN24	Symbol	Equivalent Circuit
12	11	TCONS	
14	14	AMOUT1	
15	15	VREF4	
16	16	AGCCONST	
17	17	VS	

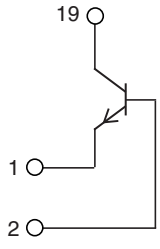
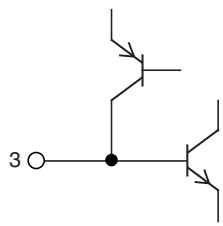
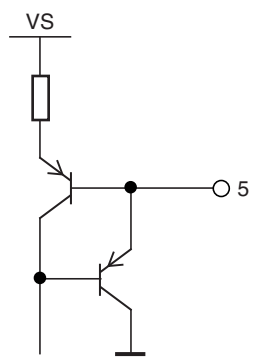
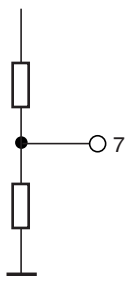
Table 10-1. Equivalent Pin Circuits (ESD Protection Circuits Not Shown) (Continued)

PIN SSO20	PIN QFN24	Symbol	Equivalent Circuit
18	19	AGCIN	

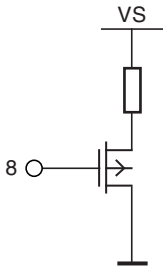
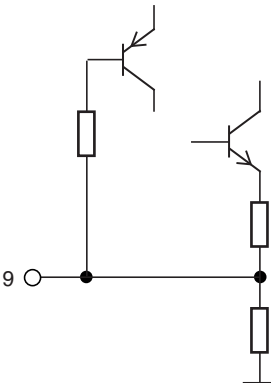
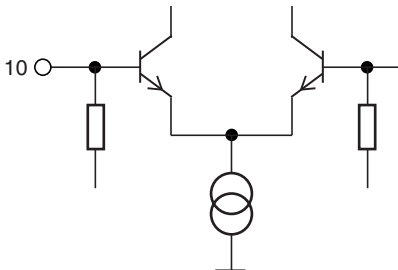
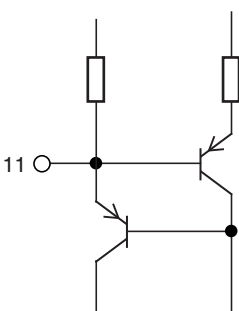
11. Ordering Information

Extended Type Number	Package	Remarks	MOQ
ATR4251-TKSY	SSO20	Sticks	830 pieces
ATR4251-TKQY	SSO20	Taped and reeled	4000 pieces
ATR4251-PFQY	QFN24, 4 mm × 4 mm	Taped and reeled	6000 pieces
ATR4251-PFPY	QFN24, 4 mm × 4 mm	Taped and reeled	1500 pieces

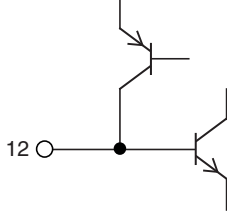
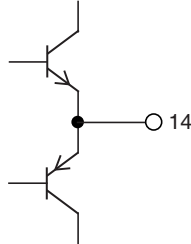
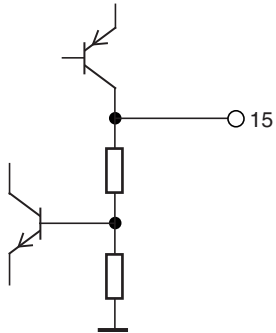
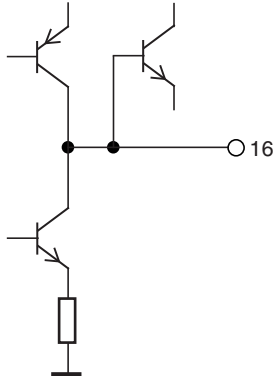
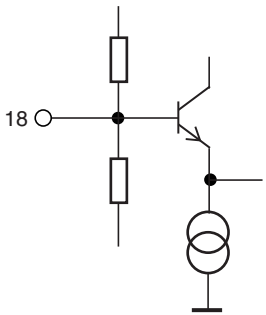
12. Package Information

Figure 12-1. SSO20

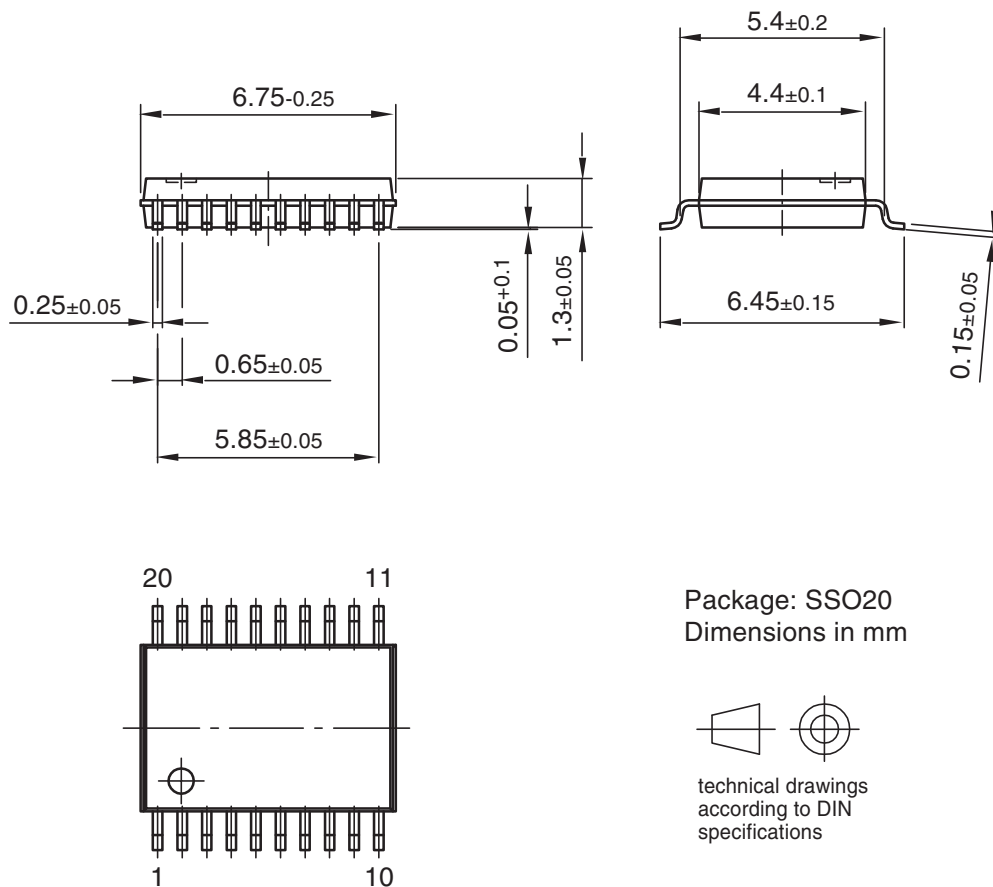

Drawing-No.: 6.543-5056.01-4

Issue: 1; 10.03.04

Figure 12-2. QFN24

Package: QFN 24 - 4 x 4
 Exposed pad 2.15 x 2.15
 (acc. JEDEC OUTLINE No. MO-220)

Dimensions in mm

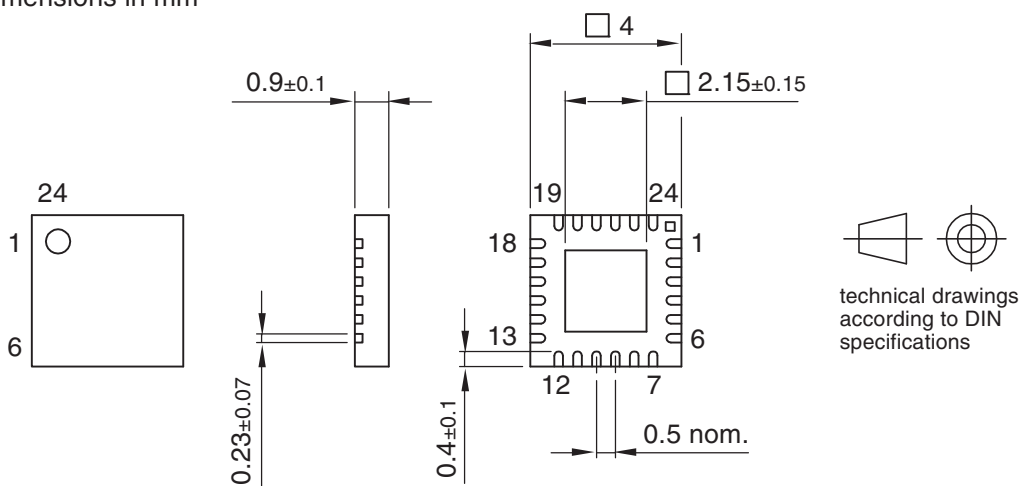

Drawing-No.: 6.543-5086.01-4

Issue: 2; 24.01.03



13. Revision History

Please note that the following page numbers referred to in this section refer to the specific revision mentioned, not to this document.

Revision No.	History
4913J-AUDR-10/09	<ul style="list-style-type: none">• Section 11 “Ordering Information” on page 18 changed
4913I-AUDR-03/08	<ul style="list-style-type: none">• Figure 1-1 “Block Diagram QFN24 Package” on page 1 changed• Figure 2-1 “Pinning QFN24” on page 3 changed• Table 2-1 “Pin Description QFN24” on page 3 changed• Table 10-1 “Equivalent Pin Circuits (ESD Protection Circuits Not Shown)” on page 14 changed• Section 11 “Ordering Information” on page 18 changed
4913H-AUDR-10/07	<ul style="list-style-type: none">• Section 7 “Electrical Characteristics” numbers 1.1, 1.2, 1.3, 1.4, 2.4, 3.5, 3.6, 4.3 and 5.1 on pages 8 to 9 changed• Section 7 “Electrical Characteristics” numbers 2.8 and 2.9 deleted• Figure 8-1 “Common Emitter Configuration” on page 11 changed
4913G-AUDR-07/07	<ul style="list-style-type: none">• Figure 8-1 “Common Emitter Configuration” on page 11 changed• Figure 9-1 “Common Base Configuration” on page 12 changed
4913F-AUDR-06/07	<ul style="list-style-type: none">• Put datasheet in a new template• Figure 8-1 “Common Emitter Configuration” on page 11 changed• Figure 8-1 “Common Base Configuration” on page 12 changed
4913E-AUDR-02/07	<ul style="list-style-type: none">• Put datasheet in a new template• Figure 1-1 exchanged with figure 1-2 on pages 1 to 2• Figure 2-1 exchanged with figure 2-2 on pages 3 to 4• Table 2-1 exchanged with table 2-2 on pages 3 to 4• Section 3.1 “AM Amplifier” on page 5 changed• Section 3.4 “FM AGC” on page 6 renamed in “FM/TV AGC” and changed• Section 7 “Electrical Characteristics” on pages 8 to 10 changed• Figure 9-1 “Common Base Configuration” on page 12 changed



Headquarters

Atmel Corporation
2325 Orchard Parkway
San Jose, CA 95131
USA
Tel: 1(408) 441-0311
Fax: 1(408) 487-2600

International

Atmel Asia
Unit 1-5 & 16, 19/F
BEA Tower, Millennium City 5
418 Kwun Tong Road
Kwun Tong, Kowloon
Hong Kong
Tel: (852) 2245-6100
Fax: (852) 2722-1369

Atmel Europe
Le Krebs
8, Rue Jean-Pierre Timbaud
BP 309
78054
Saint-Quentin-en-Yvelines Cedex
France
Tel: (33) 1-30-60-70-00
Fax: (33) 1-30-60-71-11

Atmel Japan
9F, Tonetsu Shinkawa Bldg.
1-24-8 Shinkawa
Chuo-ku, Tokyo 104-0033
Japan
Tel: (81) 3-3523-3551
Fax: (81) 3-3523-7581

Product Contact

Web Site
www.atmel.com

Technical Support
broadcast@atmel.com

Sales Contact
www.atmel.com/contacts

Literature Requests
www.atmel.com/literature

Disclaimer: The information in this document is provided in connection with Atmel products. No license, express or implied, by estoppel or otherwise, to any intellectual property right is granted by this document or in connection with the sale of Atmel products. **EXCEPT AS SET FORTH IN ATMEL'S TERMS AND CONDITIONS OF SALE LOCATED ON ATMEL'S WEB SITE, ATMEL ASSUMES NO LIABILITY WHATSOEVER AND DISCLAIMS ANY EXPRESS, IMPLIED OR STATUTORY WARRANTY RELATING TO ITS PRODUCTS INCLUDING, BUT NOT LIMITED TO, THE IMPLIED WARRANTY OF MERCHANTABILITY, FITNESS FOR A PARTICULAR PURPOSE, OR NON-INFRINGEMENT. IN NO EVENT SHALL ATMEL BE LIABLE FOR ANY DIRECT, INDIRECT, CONSEQUENTIAL, PUNITIVE, SPECIAL OR INCIDENTAL DAMAGES (INCLUDING, WITHOUT LIMITATION, DAMAGES FOR LOSS OF PROFITS, BUSINESS INTERRUPTION, OR LOSS OF INFORMATION) ARISING OUT OF THE USE OR INABILITY TO USE THIS DOCUMENT, EVEN IF ATMEL HAS BEEN ADVISED OF THE POSSIBILITY OF SUCH DAMAGES.** Atmel makes no representations or warranties with respect to the accuracy or completeness of the contents of this document and reserves the right to make changes to specifications and product descriptions at any time without notice. Atmel does not make any commitment to update the information contained herein. Unless specifically provided otherwise, Atmel products are not suitable for, and shall not be used in, automotive applications. Atmel's products are not intended, authorized, or warranted for use as components in applications intended to support or sustain life.

© 2009 Atmel Corporation. All rights reserved. Atmel®, logo and combinations thereof, and others are registered trademarks or trademarks of Atmel Corporation or its subsidiaries. Other terms and product names may be trademarks of others.

Looking for pricing, stock, or lifecycle information?

Click below to explore more details on WIN SOURCE:

- ⊖ [View ATR4251-PFPY 19 on WIN SOURCE](#)
- ⊖ [Atmel Information](#)

Optimize Your Supply Chain with WIN SOURCE Solutions

- ✓ Global Sourcing Solution
- ✓ Obsolete Management
- ✓ Cost Control Management
- ✓ Shortage Management
- ✓ Alternative Solution
- ✓ Excess Inventory Management