**Low-noise, High-dynamic-range AM/FM Antenna
Amplifier IC**

DATASHEET**Features**

- High dynamic range for AM and FM
- Integrated AGC for AM and FM
- High intercept point 3rd order for FM
- FM amplifier adjustable to various cable impedances
- High intercept point 2nd and 3rd order for AM
- Low noise output voltage
- Low power consumption
- Low output impedance AM

1. Description

The Atmel® ATR4251C is an integrated low-noise AM/FM antenna amplifier with integrated AGC in BiCMOS2S technology. The device is designed in particular for car applications, and is suitable for windshield and roof antennas.

Figure 1-1. Block Diagram QFN24 Package

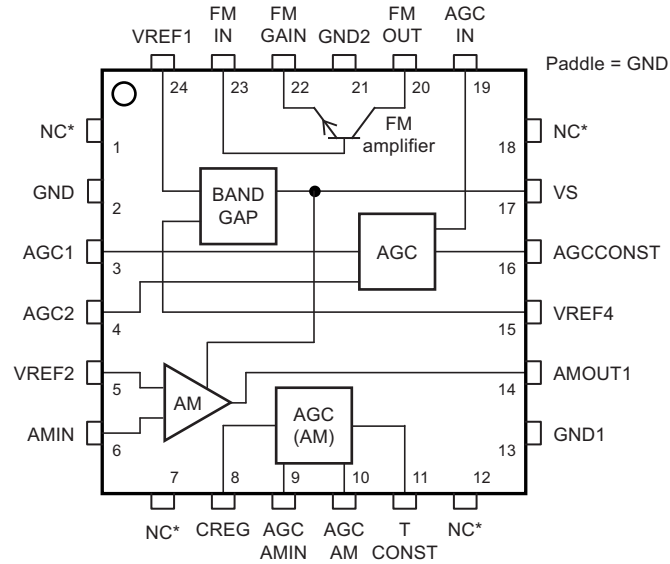

* Pin must not be connected to any other pin or supply chain except GND.

Figure 1-2. Block Diagram SSO20 Package

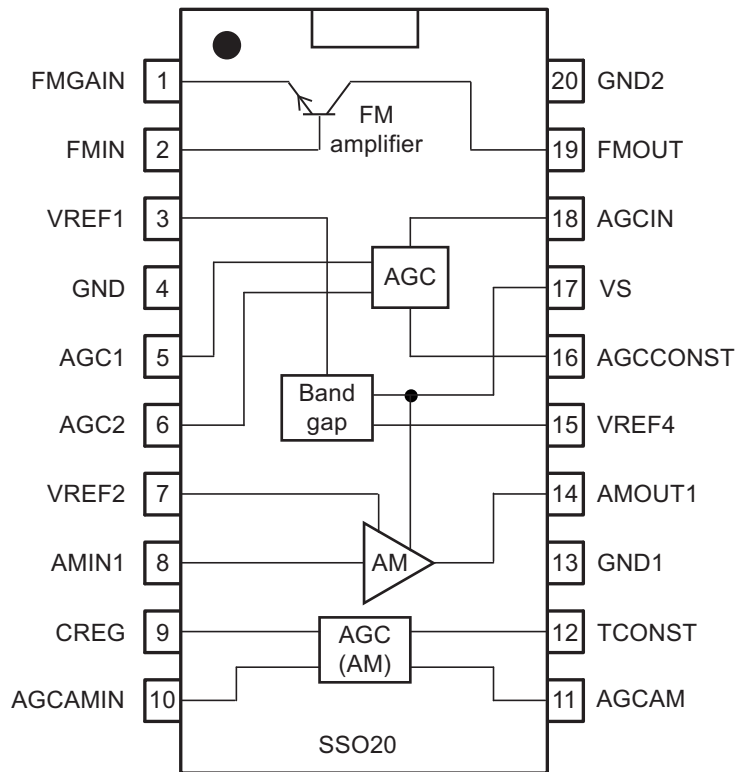

2. Pin Configuration

Figure 2-1. Pinning QFN24

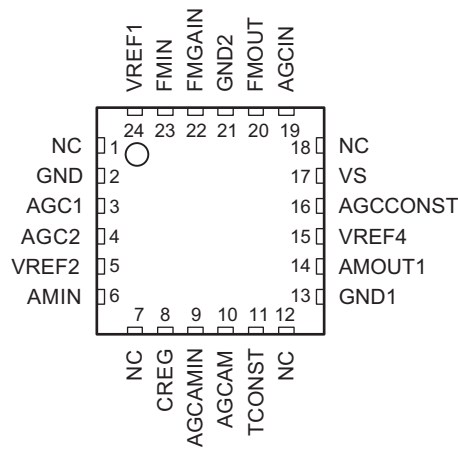

Table 2-1. Pin Description QFN24

Pin	Symbol	Function
1	NC	Pin must not be connected to any other pin or supply chain except GND.
2	GND	Ground FM
3	AGC1	AGC output for pin diode
4	AGC2	AGC output for pin diode
5	VREF2	Reference voltage for pin diode
6	AMIN	AM input, impedance matching
7	NC	Pin must not be connected to any other pin or supply chain except GND
8	CREG	AM - AGC time constant capacitance 2
9	AGCAMIN	AM - AGC input
10	AGCAM	AM - AGC output for pin diode
11	TCONST	AM - AGC - time constant capacitance 1
12	NC	Pin must not be connected to any other pin or supply chain except GND
13	GND1	Ground AM
14	AMOUT1	AM output, impedance matching
15	VREF4	Bandgap
16	AGCCONST	FM AGC time constant
17	VS	Supply voltage
18	NC	Pin must not be connected to any other pin or supply chain except GND
19	AGCIN	FM AGC input
20	FMOUT	FM output
21	GND2	Ground
22	FMGAIN	FM gain adjustment
23	FMIN	FM input
24	VREF1	Reference voltage 2.7V
Paddle	GND	Ground paddle

Figure 2-2. Pinning SSO20

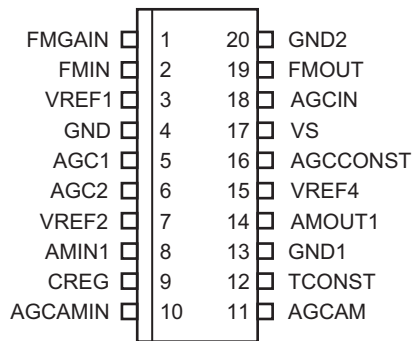

Table 2-2. Pin Description SSO20

Pin	Symbol	Function
1	FMGAIN	FM gain adjustment
2	FMIN	FM input
3	VREF1	Reference voltage 2.7V
4	GND	FM ground
5	AGC1	AGC output for PIN diode
6	AGC2	AGC output for PIN diode
7	VREF2	Reference voltage for PIN diode
8	AMIN1	AM input, impedance matching
9	CREG	AM AGC constant capacitance 2
10	AGCAMIN	AM input, AM AGC
11	AGCAM	AM AGC output for PIN diode
12	TCONST	AM AGC constant capacitance 1
13	GND1	AM ground
14	AMOUT1	AM output, impedance matching
15	VREF4	Band gap 6V
16	AGCCONST	FM AGC constant
17	VS	Supply voltage
18	AGCIN	FM AGC input
19	FMOUT	FM output
20	GND2	FM ground

3. Functional Description

The Atmel® ATR4251C is an integrated AM/FM antenna impedance matching circuit. It compensates cable losses between the antenna (for example windshield, roof, or bumper antennas) and the car radio which is usually placed far away from the antenna.

AM refers to the long wave (LW), medium wave (MW) and short wave (SW) frequency bands (150kHz to 30MHz) that are usually used for AM transmission, and FM means any of the frequency bands used world-wide for FM radio broadcast (70MHz to 110MHz).

Two separate amplifiers are used for AM and FM due to the different operating frequencies and requirements in the AM and FM band. This allows the use of separate antennas (for example, windshield antennas) for AM and FM. Of course, both amplifiers can also be connected to one antenna (for example, the roof antenna).

Both amplifiers have automatic gain control (AGC) circuits in order to avoid overdriving the amplifiers under large-signal conditions. The two separate AGC circuits prevent strong AM signals from blocking FM stations, and vice versa.

3.1 AM Amplifier

Due to the long wavelength in AM bands, the antennas used for AM reception in automotive applications must be short compared to the wavelength. Therefore these antennas do not provide 50Ω output impedance, but have an output impedance of some pF. If these (passive) antennas are connected to the car radio by a long cable, the capacitive load of this cable (some 100pF) dramatically reduces the signal level at the tuner input.

In order to overcome this problem, Atmel ATR4251C provides an AM buffer amplifier with low input capacitance (less than 2.5pF) and low output impedance (5Ω). The low input capacitance of the amplifier reduces the capacitive load at the antenna, and the low impedance output driver is able to drive the capacitive load of the cable. The voltage gain of the amplifier is close to 1 (0dB), but the insertion gain that is achieved when the buffer amplifier is inserted between antenna output and cable may be much higher (35dB). The actual value depends, of course, on antenna and cable impedance.

The input of the amplifier is connected by an external 4.7MΩ resistor to the bias voltage (pin 7, SSO20) in order to achieve high input impedance and low noise voltage.

AM tuners in car radios usually use PIN diode attenuators at their input. These PIN diode attenuators attenuate the signal by reducing the input impedance of the tuner. Therefore, a series resistor is used at the AM amplifier output in the standard application. This series resistor guarantees a well-defined source impedance for the radio tuner and protects the output of the AM amplifier from short circuit by the PIN diode attenuator in the car radio.

3.2 AM AGC

The IC is equipped with an AM AGC capability to prevent overdriving of the amplifier in case the amplifier operates near strong antenna signal level, for example, transmitters.

The AM amplifier output AMOUT1 is applied to a resistive voltage divider. This divided signal is applied to the AGC level detector input pin AGCAMPIN. The rectified signal is compared against an internal reference. The threshold of the AGC can be adjusted by adjusting the divider ratio of the external voltage divider. If the threshold is reached, pin AGCAMPIN opens an external transistor which controls PIN diode currents and limits the antenna signal and thereby prevents overdriving the AM amplifier IC.

3.3 FM Amplifier

The FM amplifier is realized with a single NPN transistor. This allows use of an amplifier configuration optimized on the requirements. For low-cost applications, the common emitter configuration provides good performance at reasonable bills of materials (BOM) cost⁽¹⁾. For high-end applications, common base configuration with lossless transformer feedback provides a high IP3 and a low noise figure at reasonable current consumption⁽²⁾. In both configurations, gain, input, and output impedance can be adjusted by modification of external components.

The temperature compensated bias voltage (VREF1) for the base of the NPN transistor is derived from an integrated band gap reference. The bias current of the FM amplifier is defined by an external resistor.

- Notes:
1. See test circuit ([Figure 8-1 on page 11](#))
 2. See application circuit ([Figure 9-1 on page 12](#))

3.4 FM/TV AGC

The IC is equipped with an AGC capability to prevent overdriving the amplifier in cases when the amplifier is operated with strong antenna signals (for example, near transmitters).

It is possible to realize an external TV antenna amplifier with integrated AGC and external RF transistor. The bandwidth of the integrated AGC circuit is 900MHz.

FM amplifier output FMOUT is connected to a capacitive voltage divider and the divided signal is applied to the AGC level detector at pin AGCIN. This level detector input is optimized for low distortion. The rectified signal is compared against an internal reference. The threshold of the AGC can be adjusted by adjusting the divider ratio of the external voltage divider. If the threshold is reached, pin AGC1 opens an external transistor which controls the PIN diode current, this limits the amplifier input signal level and prevents overdriving the FM amplifier.

4. Absolute Maximum Ratings

Stresses beyond those listed under “Absolute Maximum Ratings” may cause permanent damage to the device. This is a stress rating only and functional operation of the device at these or any other conditions beyond those indicated in the operational sections of this specification is not implied. Exposure to absolute maximum rating conditions for extended periods may affect device reliability.

Reference point is ground (pins 4 and 13 for SSO20 and pins 2, 13, 21 and Paddle for QFN24 package).

Parameters	Symbol	Value	Unit
Supply voltage	V_S	12	V
Power dissipation, P_{tot} at $T_{amb} = 90^\circ\text{C}$	P_{tot}	550	mW
Junction temperature	T_j	150	$^\circ\text{C}$
Ambient temperature SSO20 package	T_{amb}	-40 to +90	$^\circ\text{C}$
Ambient temperature QFN24 package	T_{amb}	-40 to +105	$^\circ\text{C}$
Storage temperature	T_{stg}	-50 to +150	$^\circ\text{C}$
ESD HMB QFN24	Pins 1 to 19, 21 and 24	± 2000	V
	Pins 20, 22 and 23	± 1500	V
ESD HMB SSO20	Pins 2 to 18	± 2000	V
	Pins 1, 19 and 20	± 1500	V
ESD MM	All pins	± 200	V

5. Thermal Resistance

Parameters	Symbol	Value	Unit
Junction ambient, soldered on PCB, dependent on PCB Layout for SSO 20 package	R_{thJA}	92	K/W
Junction ambient, soldered on PCB, dependent on PCB Layout for QFN package	R_{thJA}	40	K/W

6. Operating Range

Parameters	Symbol	Min.	Typ.	Max.	Unit
Supply voltage	V_S	8	10	11	V
Ambient temperature SSO20 package	T_{amb}	-40		+90	$^\circ\text{C}$
Ambient temperature QFN 24 package	T_{amb}	-40		+105	$^\circ\text{C}$

7. Electrical Characteristics

See Test Circuit, [Figure 8-1 on page 11](#); $V_S = 10V$, $T_{amb} = 25^\circ C$, unless otherwise specified. Pin numbers in () are referred to the QFN package.

No.	Parameters	Test Conditions	Pin	Symbol	Min.	Typ.	Max.	Unit	Type*
1.1	Supply currents		17 (17)	I_S	11	14	17	mA	A
1.2	Reference voltage 1 output	$I_{vref1} = 1mA$	3 (24)	V_{Ref1}	2.65	2.8	2.95	V	A
1.3	Reference voltage 2 output		7 (5)	V_{Ref2}	$0.38V_S$	$0.4V_S$	$0.42V_S$	V	B
1.4	Reference voltage 4 output	$I_{vref4} = 3mA$	15 (15)	V_{Ref4}	6.0	6.35	6.7	V	A
2 AM Impedance Matching 150kHz to 30MHz (The Frequency Response from Pin 8 to Pin 14)									
2.1	Input capacitance	$f = 1MHz$	8 (6)	C_{AMIN}	2.2	2.45	2.7	pF	D
2.2	Input leakage current	$T_{amb} = 85^\circ C$	8 (6)				40	nA	C
2.3	Output resistance		14 (14)	R_{OUT}	4	5	8	Ω	D
2.4	Voltage gain	$f = 1MHz$	8/14 (6/14)	A	0.94	0.97	1		A
2.5	Output noise voltage (rms value)	Pin 14 (14), $R_{78} = 4.7M\Omega$, $B = 9kHz$, $C_{ANT} = 30pF$ 150kHz 200kHz 500kHz 1MHz	14	V_{N1} V_{N2} V_{N3} V_{N4}		-8 -9 -11 -12	-6 -7 -9 -10	$dB\mu V$ $dB\mu V$ $dB\mu V$ $dB\mu V$	C
2.6	2 nd harmonic	$V_S = 10V$, 50 Ω load, $f_{AMIN} = 1MHz$, input voltage = 120 $dB\mu V$	AMOUT1			-60	-58	dBc	C
2.7	3 rd harmonic	$V_S = 10V$, 50 Ω load, $f_{AMIN} = 1MHz$, input voltage = 120 $dB\mu V$	AMOUT1			-53	-50	dBc	C
3 AM AGC									
3.1	Input resistance		10 (9)	$R_{AGCamin}$	40	50		k Ω	D
3.2	Input capacitance	$f = 1MHz$	10 (9)	$C_{AGCamin}$	2.6	3.2	3.8	pF	D
3.3	AGC input voltage threshold	$f = 1MHz$	10 (9)	V_{AMth}	75	77	79	$dB\mu V$	B
3.4	3 dB corner frequency	AGC threshold increased by 3dB			10			MHz	D
3.5	Minimal AGCAM output voltage	$V_{iHF} = 90dB\mu V$ at pin 10 (9)	10/11 (9/10)	V_{AGC}	$V_S - 2.4$	$V_S - 2.1$	$V_S - 1.7$	V	A
3.6	Maximal AGCAM output voltage	$V_{iHF} = 0V$ at pin 10 (9)	10/11 (9/10)	V_{AGC}	$V_S - 0.2$	$V_S - 0.1$		V	A
3.7	Maximal AGCAM output voltage ⁽¹⁾	$V_{iHF} = 0V$ at pin 10 (9) $T = +85^\circ C$	10/11 (9/10)	V_{AGC}	$V_S - 0.4$	$V_S - 0.3$		V	C
3.8	Maximum AGC sink current	$V_{iHF} = 0V$ at pin 10 (9) U (pin 12 (11)) = 2V	12 (11)	I_{AMsink}	-150	-120	-90	μA	A

*) Type means: A = 100% tested, B = 100% correlation tested, C = Characterized on samples, D = Design parameter

- Notes:
1. Leakage current of PIN diode can be adjusted by an external resistor between pin 11 and VS
 2. Demo board measurements (see [Figure 8-1 on page 11](#) "Common Emitter Configuration")
 3. Demo board measurements (see [Figure 9-1 on page 12](#) "Common Base Configuration")

7. Electrical Characteristics (Continued)

See Test Circuit, [Figure 8-1 on page 11](#); $V_S = 10V$, $T_{amb} = 25^\circ C$, unless otherwise specified. Pin numbers in () are referred to the QFN package.

No.	Parameters	Test Conditions	Pin	Symbol	Min.	Typ.	Max.	Unit	Type*
3.9	Transconductance of Level detector	$V_{IHF} = V_{AMth}$ at pin 10 (9)	10/12 (9/11)	$\frac{I_{AM \sin k}}{V_{AMth}}$		20		$\frac{\mu A}{mV_{rms}}$	C
3.10	IP3 at level detector input	Figure 9-2 on page 13 , 1MHz and 1.1MHz, 120dB μ V	10 (9)		150	170		dB μ V	D
3.11	PIN diode current generation	$d(20 \log I_{Pin-diode}) / dU_{Pin12}$ $T = 25^\circ C$, $U_{Pin12} = 2V$				30		dB/V	D
3.12	Output resistance		9 (8)	R_{OUT}	27	35	45	k Ω	D
4 FM Amplifier									
4.1	Emitter voltage		1 (22)		1.85	1.95	2.05	V	A
4.2	Emitter voltage	$T = -40^\circ C$ to $+85^\circ C$	1 (22)		1.8	2.0	2.2	V	C
4.3	Supply current limit	$R_e = 56\Omega$	19 (20)	I_{19}			37	mA	D
4.4	Maximum output voltage	$V_S = 10V$	19 (20)		12			V_{pp}	D
4.5	Input resistance	$f = 100MHz$	2 (23)	R_{FMIN}		50		Ω	D
4.6	Output resistance	$f = 100MHz$	19 (20)	R_{FMOUT}		50		Ω	D
4.7	Power gain ⁽²⁾	$f = 100MHz$	FMOUT/ FMIN	G		5		dB	A
4.8	Output noise voltage (emitter circuit) ⁽²⁾	$f = 100MHz$, $B = 120kHz$	19 (20)	V_N		-5.1		dB μ V	D
4.9	OIP3 (emitter circuit) ⁽²⁾	$f = 98 + 99MHz$	19 (20)	I_{IP3}		140		dB μ V	C
4.10	Gain ⁽³⁾					6		dB	C
4.11	Noise figure ⁽³⁾					2.8		dB	C
4.12	OIP3 ⁽³⁾	$f = 98 + 99MHz$				148		dB μ V	C
Parameters Dependent of External Components in Application Circuit: R_{FMIN}, R_{FMOUT}, G, V_N, IIP3									
5 FM AGC									
5.1	AGC threshold	$f = 100MHz$ $f = 900MHz$	18 (19)	$V_{th1,100}$ $V_{th1,900}$	81 81	83 85	85 87	dB μ V dB μ V	B B
5.2	AGC1 output voltage	AGC1 active, $V_{pin16(16)} = 5V$	5 (24)	V_{AGC}	$V_S - 2.1V$	$V_S - 1.9V$	$V_S - 1.7V$	V	C
5.3	AGC1 output voltage	AGC1 inactive, $V_{pin16(16)} = 1.7V$	5 (24)	V_{AGC}	$V_S - 0.2V$	V_S		V	C
5.4	AGC2 output voltage	AGC2 active, $V_{pin16(16)} = 1.7V$	6 (4)	V_{AGC}	$V_S - 2.1V$	$V_S - 1.9V$	$V_S - 1.7V$	V	C
5.5	AGC2 output voltage	AGC2 inactive, $V_{pin16(16)} = 5V$	6 (4)	V_{AGC}	$V_S - 0.2V$	V_S		V	C
5.6	Input resistance		18 (19)	R_{Pin18}	17	21	25	k Ω	D
5.7	Input capacitance	$F = 100MHz$	18 (19)	C_{Pin18}	1.5	1.75	1.9	pF	D

*) Type means: A = 100% tested, B = 100% correlation tested, C = Characterized on samples, D = Design parameter

- Notes:
1. Leakage current of PIN diode can be adjusted by an external resistor between pin 11 and VS
 2. Demo board measurements (see [Figure 8-1 on page 11](#) "Common Emitter Configuration")
 3. Demo board measurements (see [Figure 9-1 on page 12](#) "Common Base Configuration")

7. Electrical Characteristics (Continued)

See Test Circuit, [Figure 8-1 on page 11](#); $V_S = 10V$, $T_{amb} = 25^\circ C$, unless otherwise specified. Pin numbers in () are referred to the QFN package.

No.	Parameters	Test Conditions	Pin	Symbol	Min.	Typ.	Max.	Unit	Type*
5.8	IP3 at AGC input	Figure 9-2 on page 13 , 100MHz and 105MHz, $V_{Gen} = 120dB\mu V$	18 (19)			150		dB μV	D
5.9	IP3 at AGC input	900MHz and 920MHz $V_{Gen} = 120dB\mu V$	18 (19)			148		dB μV	D
5.10	Max. AGC sink current	$V_{iHF} = 0V$	16	I_{Pin16}	-11	-9	-7	μA	C
5.11	Transconductance	$V_{iHF} = V_{th1,100}$, $dI_{Pin16(16)} / dU_{Pin18(19)}$		dI_{Pin16} / dU_{Pin18}	0.8	1.0	1.3	mA/V (rms)	C
5.12	Gain AGC1, AGC2	$U_{Pin16} = 3V$, $dU_{Pin5(3)} / dU_{Pin16(16)}$, $-dU_{Pin6(4)} / dU_{Pin16(16)}$			0.5	0.56	0.6		C

*) Type means: A = 100% tested, B = 100% correlation tested, C = Characterized on samples, D = Design parameter

- Notes:
1. Leakage current of PIN diode can be adjusted by an external resistor between pin 11 and VS
 2. Demo board measurements (see [Figure 8-1 on page 11](#) "Common Emitter Configuration")
 3. Demo board measurements (see [Figure 9-1 on page 12](#) "Common Base Configuration")

9. Application Circuit (Demo Board)

Figure 9-1. Common Base Configuration

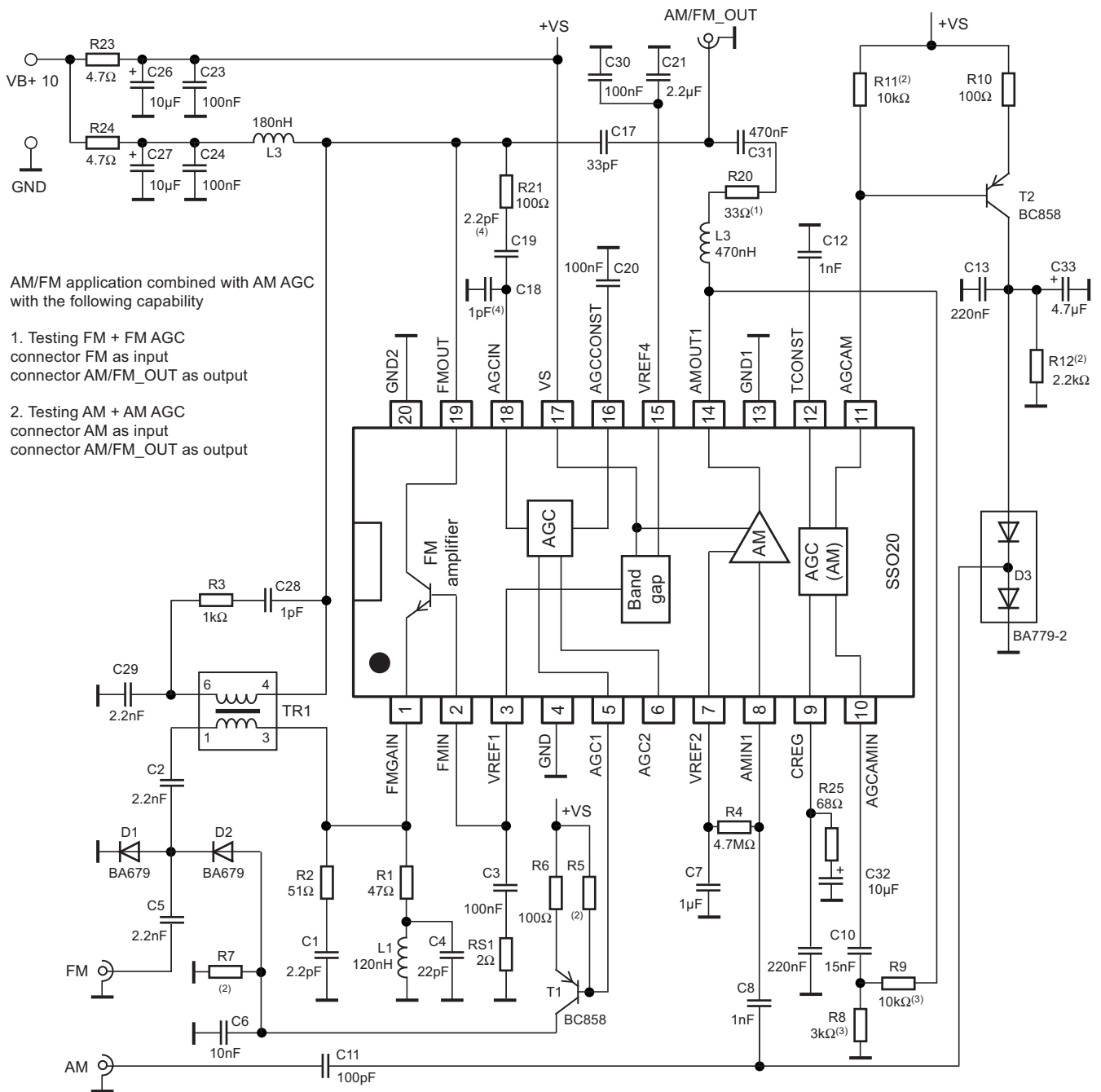

AM/FM application combined with AM AGC with the following capability

1. Testing FM + FM AGC
connector FM as input
connector AM/FM_OUT as output
2. Testing AM + AM AGC
connector AM as input
connector AM/FM_OUT as output

- (1) AM Output impedance (50Ω adjustment)
- (2) Leakage current reduction
- (3) AM AGC threshold
- (4) AM AGC threshold

Figure 9-2. Antenna Dummy for Test Purposes

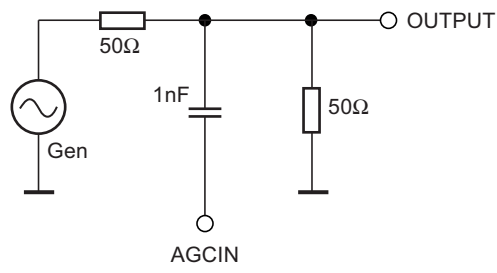

10. Internal Circuitry

Table 10-1. Equivalent Pin Circuits (ESD Protection Circuits Not Shown)

PIN SSO20	PIN QFN24	Symbol	Equivalent Circuit
1 2 19	22 23 20	FMGAIN FMIN FMOUT	
3	24	VREF1	
4, 13, 20	2, 13, 21	GND	
5 6	3 4	AGC1 AGC2	
	1, 7, 12, 18	NC	
7	5	VREF2	

Table 10-1. Equivalent Pin Circuits (ESD Protection Circuits Not Shown) (Continued)

PIN SSO20	PIN QFN24	Symbol	Equivalent Circuit
8	6	AMIN1	
9	8	CREG	
10	9	AGCAMIN	
11	10	AGCAM	

Table 10-1. Equivalent Pin Circuits (ESD Protection Circuits Not Shown) (Continued)

PIN SSO20	PIN QFN24	Symbol	Equivalent Circuit
12	11	TCONS	
14	14	AMOUT1	
15	15	VREF4	
16	16	AGCCONST	
17	17	VS	

Table 10-1. Equivalent Pin Circuits (ESD Protection Circuits Not Shown) (Continued)

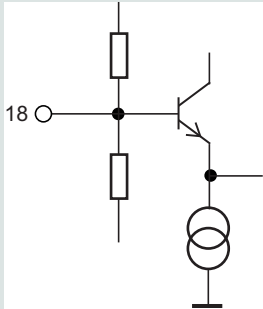
PIN SSO20	PIN QFN24	Symbol	Equivalent Circuit
18	19	AGCIN	

11. Ordering Information

Extended Type Number	Package	Remarks	MOQ
ATR4251C-TKQW	SSO20	Taped and reeled	4000 pieces
ATR4251C-PFQW	QFN24, 4mm × 4mm	Taped and reeled	6000 pieces

12. Package Information

Figure 12-1. SSO20

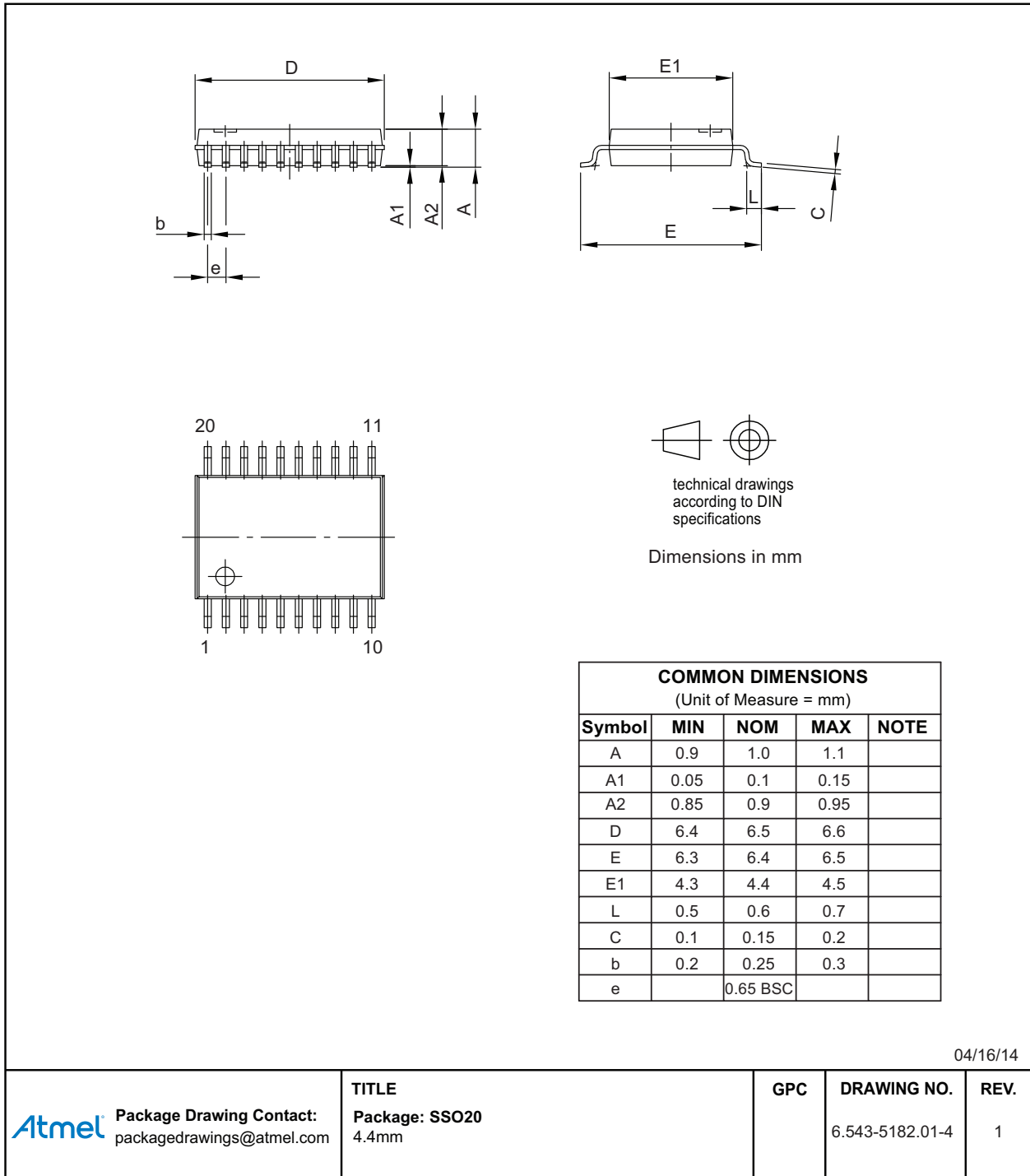
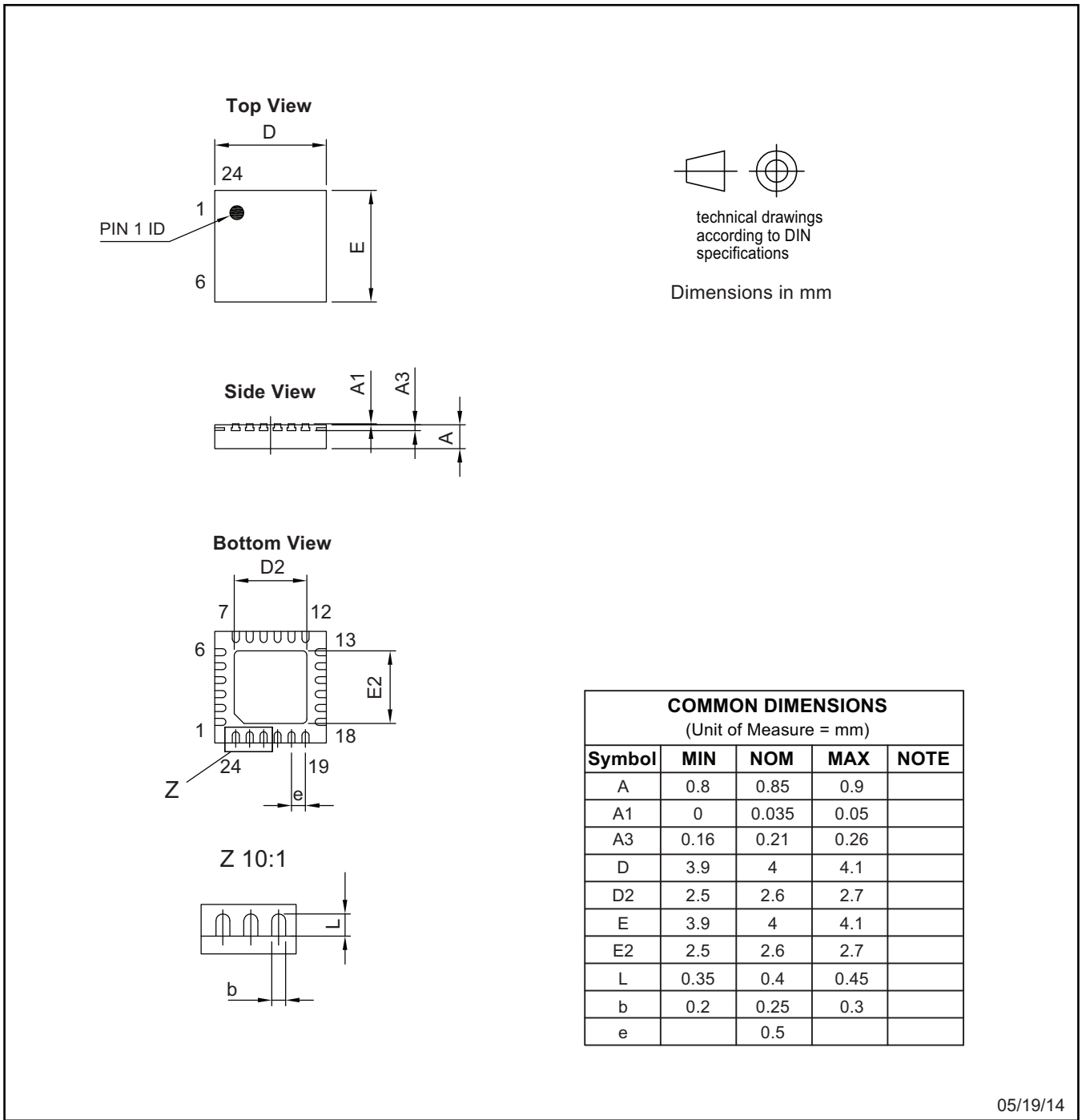

Figure 12-2. VQFN 4x4 24L



05/19/14

	Package Drawing Contact: packagedrawings@atmel.com	TITLE Package: QFN_4x4_24L Exposed pad 2.6x2.6	GPC	DRAWING NO. 6.543-5202.01-4	REV. 1

13. Revision History

Please note that the following page numbers referred to in this section refer to the specific revision mentioned, not to this document.

Revision No.	History
9258E-AUDR-11/14	<ul style="list-style-type: none">• Section 11 "Ordering Information" on page 18 updated• Section 12 "Package Information" on pages 18 to 19 updated
9258D-AUDR-08/14	<ul style="list-style-type: none">• Put datasheet in the latest template
9258C-AUDR-01/14	<ul style="list-style-type: none">• Section 7 "Electrical Characteristics" number 1.1 min. values on page 8 updated• Section 7 "Electrical Characteristics" numbers 1.2, 1.4, 2.4 min., typ. and max.values on page 8 updated
9258B-AUDR-07/13	<ul style="list-style-type: none">• Section 4 "Absolute Maximum Ratings" on page 7 updated





Looking for pricing, stock, or lifecycle information?

Click below to explore more details on WIN SOURCE:

 [View ATR4251C-TKQY on WIN SOURCE](#)

 [Atmel Information](#)

Optimize Your Supply Chain with WIN SOURCE Solutions

-  Global Sourcing Solution
-  Obsolete Management
-  Cost Control Management
-  Shortage Management
-  Alternative Solution
-  Excess Inventory Management