



**THE DATASHEET OF
IDT74LVC4245APGG**





CMOS OCTAL BUS TRANSCEIVER AND 3.3V TO 5V SHIFTER WITH 3-STATE OUT- PUTS AND 5 VOLT TOLERANT I/O

IDT74LVC4245A

FEATURES:

- 0.5 MICRON CMOS Technology
- $V_{CCA} = 5V \pm 0.5V$
- $V_{CCB} = 2.7V$ to $3.6V$
- CMOS power levels ($0.4\mu W$ typ. static)
- Rail-to-rail output swing for increased noise margin
- All inputs, outputs, and I/O are 5V tolerant
- Supports hot insertion
- Available in SOIC, SSOP, QSOP, and TSSOP packages

DRIVE FEATURES:

- High Output Drivers: $\pm 24mA$
- Reduced system switching noise

APPLICATIONS:

- 5V and 3.3V mixed voltage systems
- Data communication and telecommunication systems

DESCRIPTION:

The LVC4245A is manufactured using advanced dual metal CMOS technology. This octal noninverting bus transceiver contains two separate supply rails; B port has V_{CCB} , which is set at 3.3V, and A port has V_{CCA} , which is set at 5V. This allows for translation from a 3.3V to a 5V environment, and vice-versa.

This device is ideal for asynchronous communication between two buses (A and B). The direction control pin (DIR) controls the direction of data flow. The output enable pin (\overline{OE}) overrides the direction control and disables both ports. All inputs are designed with hysteresis for improved noise margin.

The LVC4245A has been designed with a $\pm 24mA$ output driver. This driver is capable of driving a moderate to heavy load while maintaining speed performance.

FUNCTIONAL BLOCK DIAGRAM

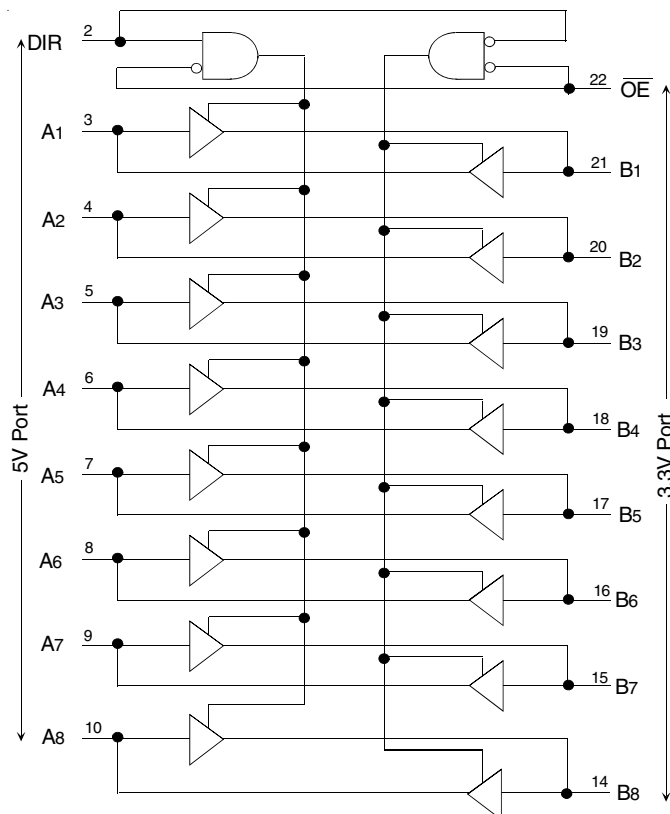

The IDT logo is a registered trademark of Integrated Device Technology, Inc.

INDUSTRIAL TEMPERATURE RANGE

February 20, 2009

PIN CONFIGURATION

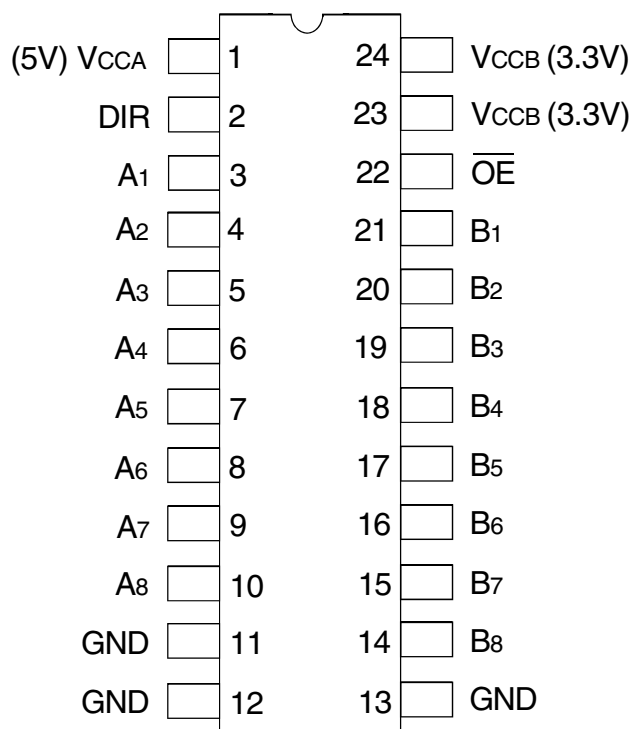

SOIC/ SSOP/ QSOP/ TSSOP
TOP VIEW

ABSOLUTE MAXIMUM RATINGS FOR V_{CCB} OR V_{CCB}(¹)

Symbol	Description	Max	Unit
V _{TERM}	Terminal Voltage with Respect to GND	-0.5 to +6.5	V
T _{STG}	Storage Temperature	-65 to +150	°C
I _{OUT}	DC Output Current	-50 to +50	mA
I _{IK} I _{OK}	Continuous Clamp Current, V _I < 0 or V _O < 0	-50	mA
I _{CC} I _{SS}	Continuous Current through each V _{CC} or GND	±100	mA

NOTE:

- Stresses greater than those listed under ABSOLUTE MAXIMUM RATINGS may cause permanent damage to the device. This is a stress rating only and functional operation of the device at these or any other conditions above those indicated in the operational sections of this specification is not implied. Exposure to absolute maximum rating conditions for extended periods may affect reliability.

CAPACITANCE (T_A = +25°C, F = 1.0MHz)

Symbol	Parameter ⁽¹⁾	Conditions	Typ.	Max.	Unit
C _{IN}	Input Capacitance	V _{IN} = 0V or V _{CCA} V _{CCA} = Open	5	—	pF
C _{I/O}	I/O Port Capacitance ⁽²⁾	V _{OUT} = V _{CCA} or GND V _{CCA} = 5V	11	—	pF
C _{I/O}	I/O Port Capacitance ⁽³⁾	V _{IN} = V _{CCB} or GND V _{CCB} = 3.3V	11	—	pF

NOTES:

- As applicable to the device type.
- For A port only.
- For B port only.

PIN DESCRIPTION

Pin Names	Description
\overline{OE}	Output Enable Input (Active LOW)
DIR	Direction Control Input
A _x	Port A Inputs or 3-State Outputs
B _x	Port B Inputs or 3-State Outputs

FUNCTION TABLE⁽¹⁾

Inputs		Outputs
\overline{OE}	DIR	
L	L	Bus B Data to Bus A
L	H	Bus A Data to Bus B
H	X	High Z state

NOTE:

- H = HIGH Voltage Level
L = LOW Voltage Level
X = Don't Care

DC ELECTRICAL CHARACTERISTICS OVER OPERATING RANGE (A PORT)

Following Conditions Apply Unless Otherwise Specified:

Operating Condition: $T_A = -40^{\circ}\text{C}$ to $+85^{\circ}\text{C}$, $V_{CCA} = 5V \pm 0.5V^{(1)}$

Symbol	Parameter	Test Conditions		Min.	Typ. ⁽²⁾	Max.	Unit
V_{IH}	Input HIGH Voltage Level	$V_{CCA} = 4.5V$ to $5.5V$		2	—	—	V
V_{IL}	Input LOW Voltage Level	$V_{CCA} = 4.5V$ to $5.5V$		—	—	0.8	V
I_{IH} I_{IL}	Input Leakage Current	$V_{CCA} = 5.5V$	$V_i = 0$ to $5.5V$	—	—	± 1	μA
I_{OZH} I_{OZL}	High Impedance Output Current (3-State Output pins)	$V_{CCA} = 5.5V$	$V_o = 0$ to $5.5V$	—	—	± 5	μA
V_H	Input Hysteresis	$V_{CCA} = 5V$		—	100	—	mV
I_{CCL} I_{CCH} I_{CCZ}	Quiescent Power Supply Current	$V_{CCA} = 5.5V$	$V_{IN} = \text{GND}$ or V_{CCA}	—	—	80	μA
ΔI_{CC}	Quiescent Power Supply Current Variation	One input at $3.4V$, other inputs at V_{CCA} or GND $V_{CCA} = 4.5V$ to $5.5V$		—	—	1.5	mA

NOTES:

- $V_{CCB} = 2.7V$ to $3.6V$.
- Typical values are at $V_{CCA} = 5V$, $+25^{\circ}\text{C}$ ambient.

DC ELECTRICAL CHARACTERISTICS OVER OPERATING RANGE (B PORT)

Following Conditions Apply Unless Otherwise Specified:

Operating Condition: $T_A = -40^{\circ}\text{C}$ to $+85^{\circ}\text{C}$, $V_{CCB} = 2.7V$ to $3.6V^{(1)}$

Symbol	Parameter	Test Conditions		Min.	Typ. ⁽²⁾	Max.	Unit
V_{IH}	Input HIGH Voltage Level	$V_{CCB} = 2.7V$ to $3.6V$		2	—	—	V
V_{IL}	Input LOW Voltage Level	$V_{CCB} = 2.7V$ to $3.6V$		—	—	0.8	V
I_{OZH} I_{OZL}	High Impedance Output Current (3-State Output pins)	$V_{CCB} = 3.6V$	$V_o = 0$ to V_{CCB}	—	—	± 5	μA
V_H	Input Hysteresis	$V_{CCB} = 3.3V$		—	100	—	mV
I_{CCL} I_{CCH} I_{CCZ}	Quiescent Power Supply Current	$V_{CCB} = 3.6V$	$V_{IN} = \text{GND}$ or V_{CCB}	—	—	50	μA
ΔI_{CC}	Quiescent Power Supply Current Variation	One input at $V_{CCB} - 0.6V$, other inputs at V_{CCB} or GND $V_{CCB} = 2.7V$ to $3.6V$		—	—	500	μA

NOTES:

- $V_{CCA} = 5V \pm 0.5V$.
- Typical values are at $V_{CCB} = 3.3V$, $+25^{\circ}\text{C}$ ambient.

OUTPUT DRIVE CHARACTERISTICS, $V_{CCA} = 5V \pm 0.5V$ (A PORT)

Symbol	Parameter	Test Conditions ⁽¹⁾		Min.	Max.	Unit
VOH	Output HIGH Voltage (B Port to A Port)	V _{CCA} = 4.5V	I _{OH} = - 0.1mA	4.3	—	V
		V _{CCA} = 5.5V		5.3	—	
		V _{CCA} = 4.5V	I _{OH} = - 24mA	3.7	—	
		V _{CCA} = 5.5V		4.7	—	
VOL	Output LOW Voltage (B Port to A Port)	V _{CCA} = 4.5V	I _{OL} = 0.1mA	—	0.2	V
		V _{CCA} = 5.5V		—	0.2	
		V _{CCA} = 4.5V	I _{OL} = 24mA	—	0.55	
		V _{CCA} = 5.5V		—	0.55	

NOTE:
1. V_{IH} and V_{IL} must be within the min. or max. range shown in the DC ELECTRICAL CHARACTERISTICS OVER OPERATING RANGE table for the appropriate V_{CC} range.
T_A = - 40°C to + 85°C, V_{CCB} = 2.7V to 3.6V.

OUTPUT DRIVE CHARACTERISTICS, $V_{CCB} = 2.7V$ TO $3.6V$ (B PORT)

Symbol	Parameter	Test Conditions ⁽¹⁾		Min.	Max.	Unit
VOH	Output HIGH Voltage (A Port to B Port)	V _{CCB} = 2.7V to 3.6V	I _{OH} = - 0.1mA	V _{CC} - 0.2	—	V
		V _{CCB} = 2.7V		I _{OH} = - 12mA	2.2	
		V _{CCB} = 3V	I _{OH} = - 24mA		2.4	
		V _{CCB} = 3V		2	—	
VOL	Output LOW Voltage (A Port to B Port)	V _{CCB} = 2.7V to 3.6V	I _{OL} = 0.1mA	—	0.2	V
		V _{CCB} = 2.7V		I _{OL} = 12mA	—	
		V _{CCB} = 3V	I _{OL} = 24mA	—	0.55	

NOTE:
1. V_{IH} and V_{IL} must be within the min. or max. range shown in the DC ELECTRICAL CHARACTERISTICS OVER OPERATING RANGE table for the appropriate V_{CC} range.
T_A = - 40°C to + 85°C, V_{CCA} = 5V ± 0.5V.

OPERATING CHARACTERISTICS, T_A = 25°C

Symbol	Parameter	Test Conditions	V _{CCA} = 5V, V _{CCB} = 3.3V	Unit
			Typical	
CPD	Power Dissipation Capacitance per Transceiver Outputs enabled	C _L = 0pF, f = 10Mhz	39.5	pF
CPD	Power Dissipation Capacitance per Transceiver Outputs disabled		5	

SWITCHING CHARACTERISTICS⁽¹⁾

Symbol	Parameter	V _{CCA} = 5V ± 0.5V V _{CCB} = 2.7V to 3.6V		Unit
		Min.	Max.	
t _{PLH}	Propagation Delay Ax to Bx	1	6.3	ns
t _{PHL}		1	6.7	
t _{PLH}	Propagation Delay Bx to Ax	1	6.1	ns
t _{PHL}		1	5	
t _{PZL}	Output Enable Time	1	8.8	ns
t _{PLZ}	\overline{OE} to Bx	1	9.8	
t _{PZL}	Output Enable Time	1	9	ns
t _{PLZ}	\overline{OE} to Ax	1	8.1	
t _{PLZ}	Output Disable Time	1	7.7	ns
t _{PHZ}	\overline{OE} to Bx	1	7.8	
t _{PLZ}	Output Disable Time	1	7	ns
t _{PHZ}	\overline{OE} to Ax	1	5.8	

NOTE:

1. See TEST CIRCUITS AND WAVEFORMS. T_A = - 40°C to + 85°C.

LOAD CIRCUIT AND VOLTAGE WAVEFORMS
PARAMETER MEASUREMENT INFORMATION (A PORT)

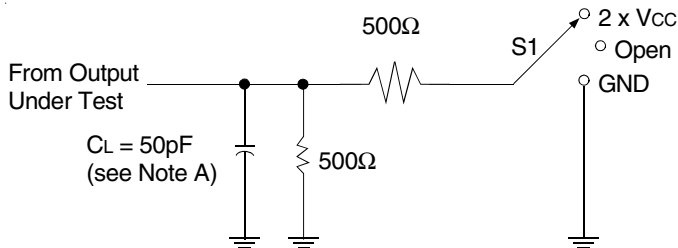

Load Circuit

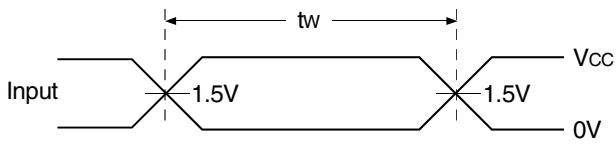

Voltage Waveforms Pulse Duration

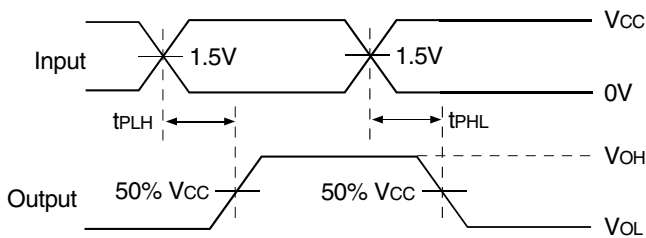

Voltage Waveforms Propagation Delay Times
Noninverting Outputs

TEST CONDITIONS

TEST	S1
t_{PLH}/t_{PHL}	Open
t_{PLZ}/t_{PZL}	$2 \times V_{CC}$
t_{PHZ}/t_{PZH}	GND

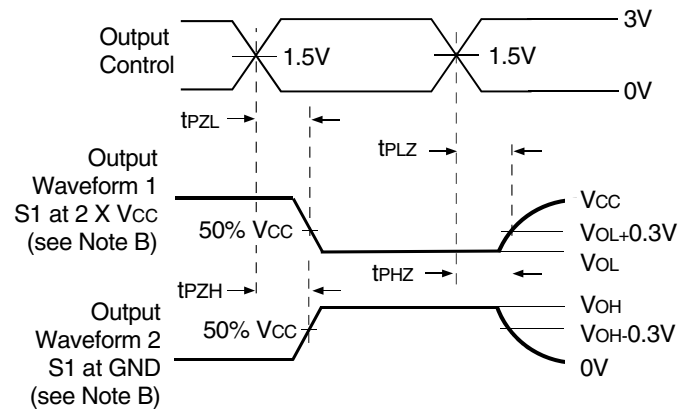

Voltage Waveforms Enable and Disable Times
Low- and High-Level Enabling

NOTES:

- C_L includes probe and jig capacitance.
- Waveform 1 is for an output with internal conditions such that the output is LOW except when disabled by the output control.
Waveform 2 is for an output with internal conditions such that the output is HIGH except when disabled by the output control.
- All input pulses are supplied by generators having the following characteristics: $PRR \leq 10\text{MHz}$; $Z_o = 50\Omega$; $t_r \leq 2.5\text{ns}$; $t_f \leq 2.5\text{ns}$.
- The outputs are measured one at a time with one transition per measurement.

LOAD CIRCUIT AND VOLTAGE WAVEFORMS
PARAMETER MEASUREMENT INFORMATION (B PORT)

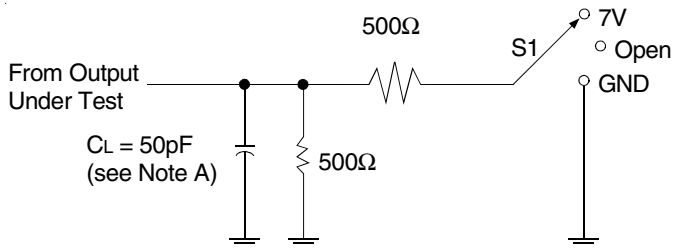

Load Circuit

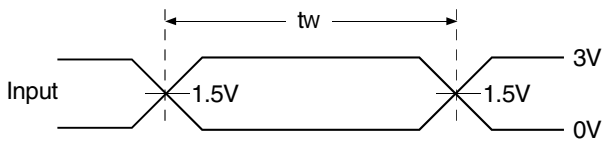

Voltage Waveforms Pulse Duration

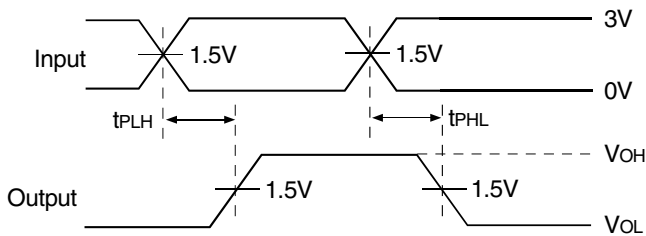

Voltage Waveforms Propagation Delay Times
Noninverting Outputs

TEST CONDITIONS

TEST	S1
t_{PLH}/t_{PHL}	Open
t_{PLZ}/t_{PZL}	7V
t_{PHZ}/t_{PZH}	GND

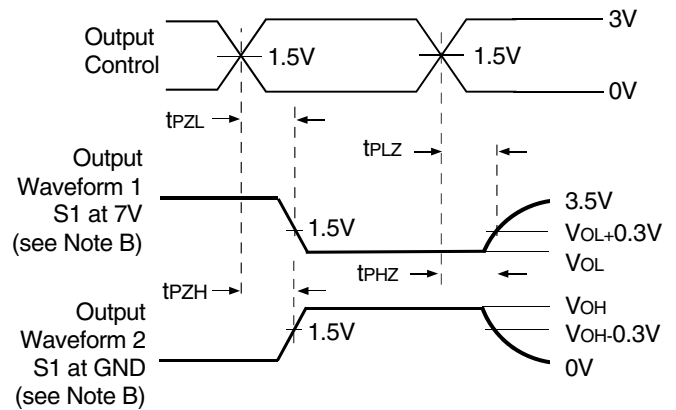

Voltage Waveforms Enable and Disable Times
Low- and High-Level Enabling

NOTES:

- C_L includes probe and jig capacitance.
- Waveform 1 is for an output with internal conditions such that the output is LOW except when disabled by the output control.
Waveform 2 is for an output with internal conditions such that the output is HIGH except when disabled by the output control.
- All input pulses are supplied by generators having the following characteristics: $PRR \leq 10\text{MHz}$; $Z_o = 50\Omega$; $t_r \leq 2.5\text{ns}$; $t_f \leq 2.5\text{ns}$.
- The outputs are measured one at a time with one transition per measurement.

ORDERING INFORMATION

<u>XX</u> Temp. Range	<u>LVC X</u> Bus-Hold	<u>XXXX</u> Device Type	<u>XX</u> Package	
			SO	Small Outline IC (gull wing)
			SOG	SOIC - Green
			PY	Shrink Small Outline Package
			PYG	SSOP - Green
			Q	Quarter Size Small Outline Package
			QG	QSOP - Green
			PG	Thin Shrink Small Outline Package
			PGG	TSSOP - Green
		4245A		Octal Bus Transceiver and 3.3V to 5V Shifter with 3-State Outputs, ±24mA
	Blank			No Bus-hold
74				-40°C to +85°C



CORPORATE HEADQUARTERS
 6024 Silver Creek Valley Road
 San Jose, CA 95138

for SALES:
 800-345-7015 or 408-284-8200
 fax: 408-284-2775
 www.idt.com

for Tech Support:
 logichelp@idt.com

Looking for pricing, stock, or lifecycle information?

Click below to explore more details on WIN SOURCE:

-  [View IDT74LVC4245APGG on WIN SOURCE](#)
-  [IDT, Integrated Device Technology Inc Information](#)

Optimize Your Supply Chain with WIN SOURCE Solutions

-  Global Sourcing Solution
-  Obsolete Management
-  Cost Control Management
-  Shortage Management
-  Alternative Solution
-  Excess Inventory Management