Features

- Three Selectable Outputs
- All Outputs Can Be Used Either for Standard (5V) or High Voltage (9V)
- Maximum Output Current at All Outputs Up to 150 mA
- On-chip Low-EMI RF Oscillator With Spread-spectrum Technology
- Control of 3 Different Swings Using 3 External Resistors
- Oscillator Frequency Range from 200 MHz to 500 MHz
- Maximum Oscillator Current Amplitude 100 mA_{pp}
- On-chip High-gain Transimpedance (IV) Amplifier
- Small Green QFN24 4 mm × 4 mm Package

Applications

- HD-DVD/DVD/CD ROM Drives
- Blu-ray/DVD/CD ROM Drives
- HD-DVD/DVD/CD Player
- Blu-ray/DVD/CD Player

1. Description

ATR0885 is a laser diode driver designed to operate three different grounded or floating laser diodes for reading CDs ($\lambda = 780$ nm), DVDs ($\lambda = 650$ nm), and HD-DVDs/Blu-ray ($\lambda = 405$ nm). An on-chip, low-EMI RF oscillator is available to reduce laser mode hopping noise. The oscillator's current amplitude can be set independently for the three selectable outputs using three resistors (RSA, RSB, RSC). The frequency setting is common to all IOUT outputs via a single resistor (RF). A logic high level on the ENOSC pin enables the spread-spectrum RF oscillator. The ATR0885 also includes a fast-settling transimpedance amplifier. It is provided to interface between the front-end monitor photo diode and the adaptive laser diode power control circuit. The gain of the transimpedance amplifier can set independently for each of the three outputs using the resistors RTIA, RTIB and RTIC.



3-output Laser Driver for HD-DVD/ Blu-ray/DVD/ CD-ROM

ATR0885

Preliminary

Summary

NOTE: This is a summary document. The complete document is available under NDA. For more information, please contact your local Atmel sales office.

4923CS-DVD-02/08



Figure 1-1. Block Diagram

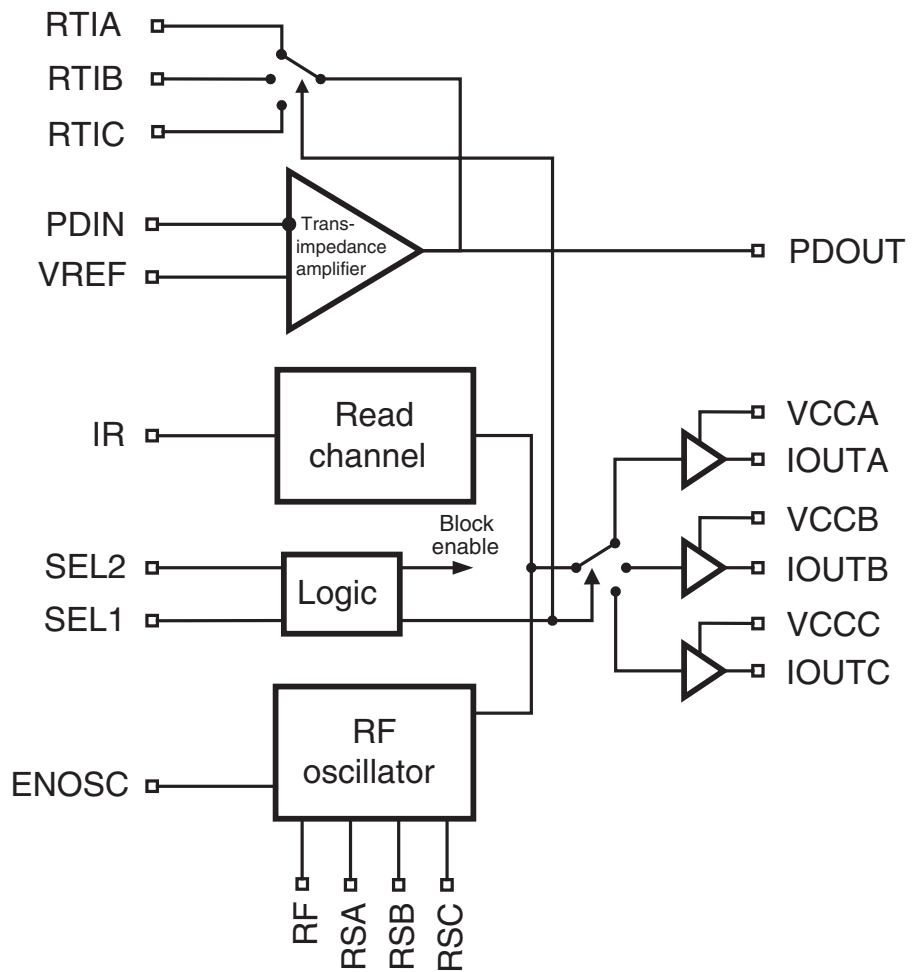

2. Pin Configuration

Figure 2-1. Pinning QFN24

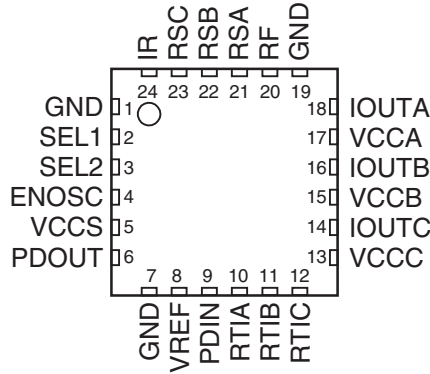

Table 2-1. Pin Description

Pin	Symbol	Type	Function
1	GND	Supply	Ground, power supply
2	SEL1	Digital	Logic pin 1 to select IOUT/ENABLE IC
3	SEL2	Digital	Logic pin 2 to select IOUT/ENABLE IC
4	ENOSC	Digital	Digital control of RF oscillator
5	VCCS	Supply	+5V power supply for internal circuit
6	PDOUT	Analog	IV amplifier output
7	GND	Supply	Ground, power supply
8	VREF	Analog	Reference voltage input
9	PDIN	Analog	Photo-diode input
10	RTIA	Analog	External resistor defining transimpedance IOUTA
11	RTIB	Analog	External resistor defining transimpedance IOUTB
12	RTIC	Analog	External resistor defining transimpedance IOUTC
13	VCCB	Supply	+5V to +9V power supply for IOUTC
14	IOUTC	Analog	Output current source C for laser diode
15	VCCB	Supply	+5V to +9V power supply for IOUTB
16	IOUTB	Analog	Output current source B for laser diode
17	VCCA	Supply	+5V to +9V power supply for IOUTA
18	IOUTA	Analog	Output current source A for laser diode
19	GND	Supply	Ground, power supply
20	RF	Analog	External resistor to GND; sets frequency of oscillator
21	RSA	Analog	External resistor to GND; sets swing of oscillator A
22	RSB	Analog	External resistor to GND; sets swing of oscillator B
23	RSC	Analog	External resistor to GND; sets swing of oscillator C
24	IR	Analog	Input current bias; ~500Ω to ground
Paddle	GND	Supply	-

3. Absolute Maximum Ratings

Stresses beyond those listed under “Absolute Maximum Ratings” may cause permanent damage to the device. This is a stress rating only and functional operation of the device at these or any other conditions beyond those indicated in the operational sections of this specification is not implied. Exposure to absolute maximum rating conditions for extended periods may affect device reliability.

Parameters	Pin	Symbol	Value	Unit
Supply voltage		V_{VCCS}	-0.5 to +6.0	V
Supply voltage output stages (VCCA, VCCB, VCCC)		V_{VCCH}	-0.5 to +9.5	V
Input voltage		V_{PDIN}	-0.5 to $V_{cc}+0.5$	V
Differential voltage	8, 9	$V_{diff_8,9}$	10.5I	V
Power dissipation		P_{max}	0.7 ⁽¹⁾ to 1 ⁽²⁾	W
Output voltage		V_{out}	-0.5 to $V_{cch}-1$	V
Junction temperature		T_j	150	°C
Storage temperature		T_{stg}	-65 to +125	°C

- Notes: 1. $R_{thJA} \leq 115$ K/W at $T_{amb} = 70^\circ\text{C}$
 2. $R_{thJA} \leq 115$ K/W at $T_{amb} = 25^\circ\text{C}$

Electrostatic sensitive device.
 Observe precautions for handling.



4. Thermal Resistance

Parameters	Symbol	Value	Unit
Junction ambient	R_{thJA}	50 ⁽¹⁾	K/W

- Note: 1. Measured with multi-layer test board (JDEC standard)

5. Recommended Operating Conditions

Parameters	Symbol	Value	Unit
Supply voltage	V_{VCCS}	4.5 to 5.5	V
High supply voltage (VCCA, VCCB, VCCC)	V_{VCCH}	V_{VCCS} to 9.0	V
Input current	I_{IR}	< 2	mA
Output voltage range	V_{PDOUT}	0.8 to ($V_{VCCS} - 1.8$)	V
External resistor to GND to set oscillator frequency	RF	> 3	k Ω
External resistor to GND to set oscillator swing	RS1, RS2, RS3	> 100	Ω
Operating temperature range	T_{amb}	0 to +70	°C
Transimpedance resistor	R_{TI}	1 to 50	k Ω
Total capacitance at PDIN	C_{PD}	< 15	pF
Load resistance	R_{Load}	> 5	k Ω
Load capacitance	C_{Load}	< 30	pF
Reference voltage	V_{REF}	1.6 to 3.0	V

6. Ordering Information

Extended Type Number	Package	Remarks
ATR0885-PFQW	Green QFN24 (4 mm × 4 mm)	Taped and reeled

7. Package Information

Package: QFN 24 - 4 x 4
 Exposed pad 2.6 x 2.6
 (acc. JEDEC OUTLINE No. MO - 220)
 Dimensions in mm

Not indicated tolerances ±0.05

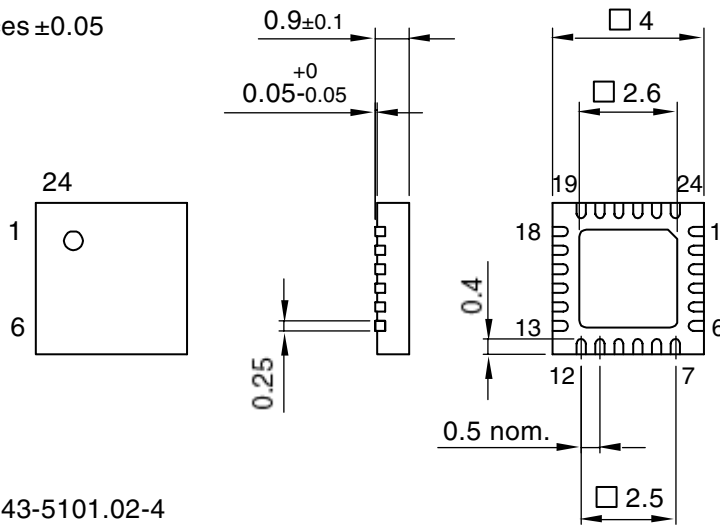

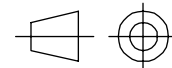
 technical drawings
 according to DIN
 specifications

Drawing-No.: 6.543-5101.02-4
 Issue: 1; 03.06.05

8. Revision History

Please note that the following page numbers referred to in this section refer to the specific revision mentioned, not to this document.

Revision No.	History
4923CC-DVD-02/08	<ul style="list-style-type: none"> Put datasheet in a new template Pin Description table (page 3): Function of Pin 2 and 3 changed



Headquarters

Atmel Corporation
2325 Orchard Parkway
San Jose, CA 95131
USA
Tel: 1(408) 441-0311
Fax: 1(408) 487-2600

International

Atmel Asia
Room 1219
Chinachem Golden Plaza
77 Mody Road Tsimshatsui
East Kowloon
Hong Kong
Tel: (852) 2721-9778
Fax: (852) 2722-1369

Atmel Europe
Le Krebs
8, Rue Jean-Pierre Timbaud
BP 309
78054
Saint-Quentin-en-Yvelines Cedex
France
Tel: (33) 1-30-60-70-00
Fax: (33) 1-30-60-71-11

Atmel Japan
9F, Tonetsu Shinkawa Bldg.
1-24-8 Shinkawa
Chuo-ku, Tokyo 104-0033
Japan
Tel: (81) 3-3523-3551
Fax: (81) 3-3523-7581

Product Contact

Web Site
www.atmel.com

Technical Support
dvd_ddd@atmel.com

Sales Contact
www.atmel.com/contacts

Literature Requests
www.atmel.com/literature

Disclaimer: The information in this document is provided in connection with Atmel products. No license, express or implied, by estoppel or otherwise, to any intellectual property right is granted by this document or in connection with the sale of Atmel products. **EXCEPT AS SET FORTH IN ATMEL'S TERMS AND CONDITIONS OF SALE LOCATED ON ATMEL'S WEB SITE, ATMEL ASSUMES NO LIABILITY WHATSOEVER AND DISCLAIMS ANY EXPRESS, IMPLIED OR STATUTORY WARRANTY RELATING TO ITS PRODUCTS INCLUDING, BUT NOT LIMITED TO, THE IMPLIED WARRANTY OF MERCHANTABILITY, FITNESS FOR A PARTICULAR PURPOSE, OR NON-INFRINGEMENT. IN NO EVENT SHALL ATMEL BE LIABLE FOR ANY DIRECT, INDIRECT, CONSEQUENTIAL, PUNITIVE, SPECIAL OR INCIDENTAL DAMAGES (INCLUDING, WITHOUT LIMITATION, DAMAGES FOR LOSS OF PROFITS, BUSINESS INTERRUPTION, OR LOSS OF INFORMATION) ARISING OUT OF THE USE OR INABILITY TO USE THIS DOCUMENT, EVEN IF ATMEL HAS BEEN ADVISED OF THE POSSIBILITY OF SUCH DAMAGES.** Atmel makes no representations or warranties with respect to the accuracy or completeness of the contents of this document and reserves the right to make changes to specifications and product descriptions at any time without notice. Atmel does not make any commitment to update the information contained herein. Unless specifically provided otherwise, Atmel products are not suitable for, and shall not be used in, automotive applications. Atmel's products are not intended, authorized, or warranted for use as components in applications intended to support or sustain life.

© 2008 Atmel Corporation. All rights reserved. Atmel®, logo and combinations thereof, and others are registered trademarks or trademarks of Atmel Corporation or its subsidiaries. Other terms and product names may be trademarks of others.

Looking for pricing, stock, or lifecycle information?

Click below to explore more details on WIN SOURCE:

 [View ATR0885-PFQW](#) on WIN SOURCE

 [Atmel](#) Information

Optimize Your Supply Chain with WIN SOURCE Solutions

-  Global Sourcing Solution
-  Obsolete Management
-  Cost Control Management
-  Shortage Management
-  Alternative Solution
-  Excess Inventory Management