



**THE DATASHEET OF
ICS950602CGLF**



Programmable Timing Control Hub™ for PII/III™

Recommended Application:

VIA Mobile PL133T and PLE133T Chipsets.

Output Features:

- 2 - CPU clocks @ 2.5V
- 1 - Pairs of differential CPU clocks @ 3.3V
- 7 - PCI including 1 free running @ 3.3V
- 7 - SDRAM @ 3.3V
- 1 - 48MHz @ 3.3V fixed
- 1 - 24_48MHz selectable @ 3.3V
- 2 - REF @ 3.3V, 14.318MHz

Features/Benefits:

- Programmable output frequency.
- Programmable output divider ratios.
- Programmable output rise/fall time.
- Programmable output skew.
- Programmable spread percentage for EMI control.
- Watchdog timer technology to reset system if system malfunctions.
- Programmable watch dog safe frequency.
- Support I²C Index read/write and block read/write operations.
- Uses external 14.318MHz crystal.

Key Specifications:

- CPU Output Jitter <200ps
- CPU Output Skew <175ps
- PCI to PCI Output Skew <500ps

Pin Configuration

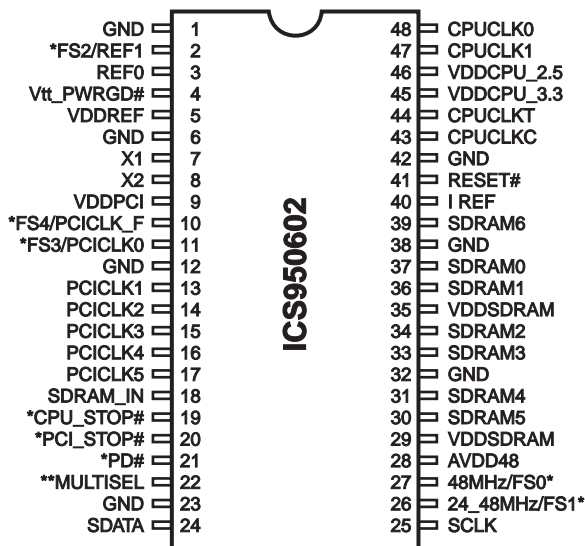

48-Pin SSOP & TSSOP

* Internal Pull-up resistor of 120K to VDD

** these inputs have 120K internal pull-down to GND

Block Diagram

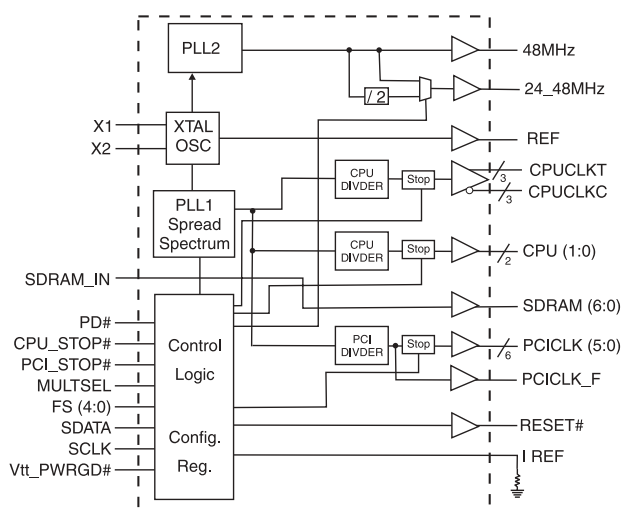

Host Swing Select Functions

MULTISEL0	Board Target Trace/Term Z	Reference R, Iref = V _{DD} /(3*Rr)	Output Current	Voh @ Z
0	50 ohms	Rr = 221 1%, Iref = 5.00mA	Ioh = 4 * I REF	1.0V @ 50
1	50 ohms	Rr = 475 1%, Iref = 2.32mA	Ioh = 6 * I REF	0.7V @ 50

General Description

The **ICS950602** is a single chip clock solution for VIA Mobile PL133T and PLE133T chipsets. It provides all necessary clock signals for such a system.

The **ICS950602** is part of a whole new line of ICS clock generators and buffers called TCH™ (Timing Control Hub). ICS is the first to introduce a whole product line which offers full programmability and flexibility on a single clock device. This part incorporates ICS's newest clock technology which offers more robust features and functionality. Employing the use of a serially programmable I²C interface, this device can adjust the output clocks by configuring the frequency setting, the output divider ratios, selecting the ideal spread percentage, the output skew, the output strength, and enabling/disabling each individual output clock. TCH also incorporates ICS's Watchdog Timer technology and a reset feature to provide a safe setting under unstable system conditions. M/N control can configure output frequency with resolution up to 0.1MHz increment. With all these programmable features, ICS' TCH makes motherboard testing, tuning and improvement very simple.

Pin Description

PIN NUMBER	PIN NAME	TYPE	DESCRIPTION
1, 6, 12, 23, 32, 38, 42,	GND	PWR	Ground pins for 3.3V supply
5, 9, 29, 35	VDD	PWR	3.3V power supply
2	FS2	IN	Logic input frequency select bit. Input latched at power on.
	REF1	OUT	3.3V, 14.318MHz reference clock output.
3	REF0	OUT	3.3V, 14.318MHz reference clock output.
4	Vtt_PWRGD#	IN	This 3.3V LVTTTL input is a level sensitive strobe used to determine when FS (4:0) are valid and are ready to be sampled (active low)
7	X1	IN	Crystal input, has internal load cap (33pF) and feedback resistor from X2
8	X2	OUT	Crystal output, nominally 14.318MHz. Has internal load cap (33pF)
10	FS4	IN	Logic input frequency select bit. Input latched at power on.
	PCICLK_F	OUT	3.3V PCI clock output
11	FS3	IN	Logic input frequency select bit. Input latched at power on.
	PCICLK0	OUT	3.3V PCI clock output
17, 16, 15, 14, 13	PCICLK (5:1)	OUT	3.3V PCI clock outputs
18	SDRAM_IN	IN	SDRAM buffer input pin.
19	CPU_STOP#	IN	Stops all CPUCLKs clocks at logic 0 level, when input low
20	PCI_STOP#	IN	Stops all PCICLKs besides the PCICLK_F clocks at logic 0 level, when input low
21	PD#	IN	Asynchronous active low input pin used to power down the device into a low power state. The internal clocks are disabled and the VCO and the crystal are stopped. The latency of the power down will not be greater than 3ms.
22	MULTSEL	IN	3.3V LVTTTL input for selecting the current multiplier for CPU outputs.
24	SDATA	I/O	Data pin for I ² C circuitry 5V tolerant
25	SCLK	IN	Clock pin for I ² C circuitry 5V tolerant
26	FS1	IN	Logic input frequency select bit. Input latched at power on.
	48_24MHz	OUT	Selectable 48 or 24MHz output
27	FS0	IN	Logic input frequency select bit. Input latched at power on.
	48MHz	OUT	3.3V Fixed 48MHz clock output.
28	AVDD48	PWR	3.3V analog power supply for 48 or 24MHz outputs.
30, 31, 33, 34, 36, 37, 39	SDRAM (5:0, 6)	OUT	SDRAM clock outputs.
40	I REF	OUT	This pin establishes the reference current for the CPUCLK pairs. This pin requires a fixed precision resistor tied to ground in order to establish the appropriate current.
41	RESET#	OUT	Real time system reset signal for frequency value or watchdog timer timeout. This signal is active low.
43	CPUCLKC	OUT	"Complementary" clock of differential pair CPU outputs. These are current outputs and external resistors are required for voltage bias.
44	CPUCLKT	OUT	"True" clock of differential pair CPU outputs. These are current outputs and external resistors are required for voltage bias.
45	VDDCPU_3.3	PWR	3.3V power for CPU differential clocks.
46	VDDCPU_2.5	PWR	2.5V power for CPU clocks.
47, 48	CPUCLK (1:0)	OUT	CPU clock outputs.

General I²C serial interface information

How to Write:

- Controller (host) sends a start bit.
- Controller (host) sends the write address D2_(H)
- ICS clock will **acknowledge**
- Controller (host) sends the beginning byte location = N
- ICS clock will **acknowledge**
- Controller (host) sends the data byte count = X
- ICS clock will **acknowledge**
- Controller (host) starts sending **Byte N through Byte N + X - 1**
(see Note 2)
- ICS clock will **acknowledge** each byte **one at a time**
- Controller (host) sends a Stop bit

How to Read:

- Controller (host) will send start bit.
- Controller (host) sends the write address D2_(H)
- ICS clock will **acknowledge**
- Controller (host) sends the beginning byte location = N
- ICS clock will **acknowledge**
- Controller (host) will send a separate start bit.
- Controller (host) sends the read address D3_(H)
- ICS clock will **acknowledge**
- ICS clock will send the data byte count = X
- ICS clock sends **Byte N + X - 1**
- ICS clock sends **Byte 0 through byte X (if X_(H) was written to byte 8).**
- Controller (host) will need to acknowledge each byte
- Controller (host) will send a not acknowledge bit
- Controller (host) will send a stop bit

Index Block Write Operation		
Controller (Host)		ICS (Slave/Receiver)
T	starT bit	
Slave Address D2 _(H)		
WR	WRite	
		ACK
Beginning Byte = N		
		ACK
Data Byte Count = X		
		ACK
Beginning Byte N		X Byte
○		
○		
○		
Byte N + X - 1		
		ACK
P	stoP bit	

Index Block Read Operation		
Controller (Host)		ICS (Slave/Receiver)
T	starT bit	
Slave Address D2 _(H)		
WR	WRite	
		ACK
Beginning Byte = N		
		ACK
RT	Repeat starT	
Slave Address D3 _(H)		
RD	ReaD	
		ACK
		Data Byte Count = X
ACK		
ACK		X Byte
○		
○		
○		
		Byte N + X - 1
N	Not acknowledge	
P	stoP bit	

*See notes on the following page.

Byte 0: Functionality and frequency select register (Default=0)

Bit	Description								PWD	
Bit (2:1,6:4)	Bit2	Bit1	Bit6	Bit5	Bit4	CPUCLK MHz	PCICLK MHz	Spread %	Note 1	
	FS4	FS3	FS2	FS1	FS0					
	0	0	0	0	0	0	200.00	33.30		+/-0.25% center spread
	0	0	0	0	1	1	190.00	38.00		+/-0.25% center spread
	0	0	0	1	0	0	180.00	36.00		+/-0.25% center spread
	0	0	0	1	1	1	170.00	34.00		+/-0.25% center spread
	0	0	1	0	0	0	166.00	33.20		+/-0.25% center spread
	0	0	1	0	1	1	160.00	32.00		+/-0.25% center spread
	0	0	1	1	0	0	150.00	37.50		+/-0.25% center spread
	0	0	1	1	1	1	145.00	36.30		+/-0.25% center spread
	0	1	0	0	0	0	140.00	35.00		+/-0.25% center spread
	0	1	0	0	1	1	136.00	34.00		+/-0.25% center spread
	0	1	0	1	0	0	130.00	32.50		+/-0.25% center spread
	0	1	0	1	1	1	124.00	31.00		+/-0.25% center spread
	0	1	1	0	0	0	67.20	33.60		+/-0.25% center spread
	0	1	1	0	1	1	100.90	33.63		+/-0.25% center spread
	0	1	1	1	0	0	118.00	39.30		+/-0.25% center spread
	0	1	1	1	1	1	134.40	33.60		+/-0.25% center spread
	1	0	0	0	0	0	67.00	33.50		+/-0.25% center spread
	1	0	0	0	1	1	100.50	33.50		+/-0.25% center spread
	1	0	0	1	0	0	115.00	38.30		+/-0.25% center spread
	1	0	0	1	1	1	133.90	33.47		+/-0.25% center spread
	1	0	1	0	0	0	66.80	33.40		+/-0.25% center spread
	1	0	1	0	1	1	100.20	33.40		+/-0.25% center spread
	1	0	1	1	0	0	110.00	36.70		+/-0.25% center spread
	1	0	1	1	1	1	133.60	33.40		+/-0.25% center spread
	1	1	0	0	0	0	105.00	35.00		+/-0.25% center spread
	1	1	0	0	1	1	90.00	30.00		+/-0.25% center spread
	1	1	0	1	0	0	85.00	28.30		+/-0.25% center spread
1	1	0	1	1	1	78.00	39.00	+/-0.25% center spread		
1	1	1	0	0	0	66.60	33.30	+/-0.25% center spread		
1	1	1	0	1	1	100.00	33.30	0 to -0.5% down spread		
1	1	1	1	0	0	75.00	37.50	+/-0.25% center spread		
1	1	1	1	1	1	133.30	33.30	0 to -0.5% down spread		
Bit 3	0 - Frequency is selected by hardware select, latched inputs 1 - Frequency is selected by Bit 2,7:4								0	
Bit 0	0 - Normal 1 - Spread spectrum enable								0	
Bit 7	0 - Watch dog safe frequency will be selected by latch inputs 1 - Watch dog safe frequency will be programmed by Byte 10 bit (4:0)								0	

Notes:

1. Default at power-up will be for latched logic inputs to define frequency, as displayed by Bit 3.



Byte 1: Output Control Register
(1 = enable, 0 = disable)

Bit	Pin#	PWD	Description
Bit7	-	X	FS4 Read back
Bit6	-	X	FS3 Read back
Bit5	-	X	FS2 Read back
Bit4	-	X	FS1 Read back
Bit3	-	X	FS0 Read back
Bit2	48	1	CPUCLK0
Bit1	47	1	CPUCLK1
Bit0	44, 43	1	CPUCLKT, CPUCLKC

Byte 2: Output Control Register
(1 = enable, 0 = disable)

Bit	Pin#	PWD	Description
Bit7	39	1	SDRAM6
Bit6	10	1	PCICLK_F
Bit5	17	1	PCICLK5
Bit4	16	1	PCICLK4
Bit3	15	1	PCICLK3
Bit2	14	1	PCICLK2
Bit1	13	1	PCICLK1
Bit0	11	1	PCICLK0

Byte 3: Output Control Register
(1 = enable, 0 = disable)

Bit	Pin#	PWD	Description
Bit7	-	0	RESET gear shift detect 1 = Enable, 0 = Disable
Bit6	-	0	SEL24_48: 0 = 24, 1 = 48
Bit5	27	1	48MHz
Bit4	26	1	24_48MHz
Bit3	-	0	Reserved
Bit2	31, 30	1	SDRAM (4:5)
Bit1	34, 33	1	SDRAM (2:3)
Bit0	37, 36	1	SDRAM (0:1)

Byte 4: Output Control Register
(1 = enable, 0 = disable)

Bit	Pin#	PWD	Description
Bit 7	-	X	MULTSEL Read back
Bit 6	-	X	Reserved
Bit 5	-	X	Reserved
Bit 4	-	X	Reserved
Bit 3	-	X	Reserved
Bit 2	-	X	Reserved
Bit 1	-	X	Reserved
Bit 0	-	X	Reserved



Byte 5: Output Control Register
(1 = enable, 0 = disable)

Bit	Pin#	PWD	Description
Bit 7	-	0	Reserved
Bit 6	-	0	Reserved
Bit 5	-	0	Reserved
Bit 4	-	0	CPUCLK0 Free running control, 0 = Not free running 1 = Free running
Bit 3	-	0	CPUCLK1 Free running control, 0 = Not free running 1 = Free running
Bit 2	-	0	CPUCLKT/C Free running control, 0 = Not free running 1 = Free running
Bit 1	2	1	REF1
Bit 0	3	1	REF0

Byte 6: Reserved Register
(1 = enable, 0 = disable)

Bit	Pin#	PWD	Description
Bit 7	-	0	Reserved
Bit 6	-	0	Reserved
Bit 5	-	0	Reserved
Bit 4	-	0	Reserved
Bit 3	-	0	Reserved
Bit 2	-	0	Reserved
Bit 1	-	0	Reserved
Bit 0	-	0	Reserved

Byte 7: Byte Count Read Back Register

Bit	Name	PWD	Description
Bit 7	Byte7	0	Default Byte count read back is 15 Byte.
Bit 6	Byte6	0	
Bit 5	Byte5	0	
Bit 4	Byte4	0	
Bit 3	Byte3	1	
Bit 2	Byte2	1	
Bit 1	Byte1	1	
Bit 0	Byte0	1	

Byte 8: Vendor ID Register

Bit	Name	PWD	Description
Bit 7	Revision ID Bit3	X	Revision ID values will be based on individual device's revision
Bit 6	Revision ID Bit2	X	
Bit 5	Revision ID Bit1	X	
Bit 4	Revision ID Bit0	X	
Bit 3	Vendor ID Bit3	0	(Reserved)
Bit 2	Vendor ID Bit2	0	(Reserved)
Bit 1	Vendor ID Bit1	0	(Reserved)
Bit 0	Vendor ID Bit0	1	(Reserved)



Byte 9: Watchdog Timer Count Register

Bit	Name	PWD	Description
Bit 7	WD7	0	The decimal representation of these 8 bits correspond to X • 290ms the watchdog timer will wait before it goes to alarm mode and reset the frequency to the safe setting. Default at power up is 16 • 290ms = 4.64 seconds.
Bit 6	WD6	0	
Bit 5	WD5	0	
Bit 4	WD4	1	
Bit 3	WD3	0	
Bit 2	WD2	0	
Bit 1	WD1	0	
Bit 0	WD0	0	

Byte 10: Programming Enable bit 8 Watchdog Control Register

Bit	Name	PWD	Description
Bit 7	Program Enable	0	Programming Enable bit 0 = no programming. Frequencies are selected by HW latches or Byte0 1 = enable all FC programing.
Bit 6	WD Enable	0	Watchdog Enable bit. This bit will over write WDEN latched value. 0 = disable, 1 = Enable.
Bit 5	WD Alarm	0	Watchdog Alarm Status 0 = normal 1= alarm status
Bit 4	SF4	1	Watchdog safe frequency bits. Writing to these bits will configure the safe frequency corresponding to Byte 0 Bit 2, 7:4 table
Bit 3	SF3	1	
Bit 2	SF2	1	
Bit 1	SF1	1	
Bit 0	SF0	1	

Byte 11: VCO Frequency M Divider (Reference divider) Control Register

Bit	Name	PWD	Description
Bit 7	Ndiv 8	X	N divider bit 8
Bit 6	Mdiv 6	X	The decimal respresentation of Mdiv (6:0) correspod to the reference divider value. Default at power up is equal to the latched inputs selection.
Bit 5	Mdiv 5	X	
Bit 4	Mdiv 4	X	
Bit 3	Mdiv 3	X	
Bit 2	Mdiv 2	X	
Bit 1	Mdiv 1	X	
Bit 0	Mdiv 0	X	

Byte 12: VCO Frequency N Divider (VCO divider) Control Register

Bit	Name	PWD	Description
Bit 7	Ndiv 7	X	The decimal representation of Ndiv (8:0) correspond to the VCO divider value. Default at power up is equal to the latched inputs selecton. Notice Ndiv 8 is located in Byte 11.
Bit 6	Ndiv 6	X	
Bit 5	Ndiv 5	X	
Bit 4	Ndiv 4	X	
Bit 3	Ndiv 3	X	
Bit 2	Ndiv 2	X	
Bit 1	Ndiv 1	X	
Bit 0	Ndiv 0	X	



Byte 13: Spread Spectrum Control Register

Bit	Name	PWD	Description
Bit 7	SS 7	X	The Spread Spectrum will program the spread percentage. Spread percent needs to be calculated based on the VCO frequency, spreading profile, spreading amount and spread frequency. It is recommended to use ICS software for spread programming. Default power on is latched FS divider.
Bit 6	SS 6	X	
Bit 5	SS 5	X	
Bit 4	SS 4	X	
Bit 3	SS 3	X	
Bit 2	SS 2	X	
Bit 1	SS 1	X	
Bit 0	SS 0	X	

Byte 14: Spread Spectrum Control Register

Bit	Name	PWD	Description
Bit 7	Reserved	X	Reserved
Bit 6	Reserved	X	Reserved
Bit 5	Reserved	X	Reserved
Bit 4	SS 12	X	Spread Spectrum Bit 12
Bit 3	SS 11	X	Spread Spectrum Bit 11
Bit 2	SS 10	X	Spread Spectrum Bit 10
Bit 1	SS 9	X	Spread Spectrum Bit 9
Bit 0	SS 8	X	Spread Spectrum Bit 8

Absolute Maximum Ratings

Supply Voltage	5.5 V
Logic Inputs	GND -0.5 V to $V_{DD} + 0.5$ V
Ambient Operating Temperature	0°C to +70°C
Case Temperature	115°C
Storage Temperature	-65°C to +150°C

Stresses above those listed under *Absolute Maximum Ratings* may cause permanent damage to the device. These ratings are stress specifications only and functional operation of the device at these or any other conditions above those listed in the operational sections of the specifications is not implied. Exposure to absolute maximum rating conditions for extended periods may affect product reliability.

Electrical Characteristics - Input/Supply/Common Output Parameters

$T_A = 0 - 70^\circ\text{C}$; Supply Voltage $V_{DD} = 3.3$ V +/-5%

PARAMETER	SYMBOL	CONDITIONS	MIN	TYP	MAX	UNITS
Input High Voltage	V_{IH}		2		$V_{DD} + 0.3$	V
Input Low Voltage	V_{IL}		$V_{SS} - 0.3$		0.8	V
Input High Current	I_{IH}	$V_{IN} = V_{DD}$	-5		5	mA
Input Low Current	I_{IL1}	$V_{IN} = 0$ V; Inputs with no pull-up resistors	-5			mA
	I_{IL2}	$V_{IN} = 0$ V; Inputs with pull-up resistors	-200			
Operating Supply Current	$I_{DD3.3OP}$	$C_L = 0$ pF; Select @ 67 MHz			100	mA
		$C_L = \text{Full load}$, SDRAM not running		144	280	
Powerdown Current	$I_{DD3.3PD}$	IREF = 2.32 mA			20	mA
		IREF = 5 mA		22	37	
Input Frequency	F_i	$V_{DD} = 3.3$ V		14.32		MHz
Pin Inductance	L_{pin}				7	nH
Input Capacitance ¹	C_{IN}	Logic Inputs			5	pF
	C_{OUT}	Output pin capacitance			6	pF
	C_{INX}	X1 & X2 pins	27		45	pF
Transition time ¹	T_{trans}	To 1st crossing of target frequency			3	ms
Settling time ¹	T_s	From 1st crossing to 1% target frequency			3	ms
Clk Stabilization ¹	T_{STAB}	From $V_{DD} = 3.3$ V to 1% target frequency			3	ms
Delay ¹	t_{PZH}, t_{PZL}	Output enable delay (all outputs)	1		10	ns
	t_{PHZ}, t_{PLZ}	Output disable delay (all outputs)	1		10	ns

¹Guaranteed by design, not 100% tested in production.

Electrical Characteristics - CPUCLK(T,C)

T_A = 0 - 70°C; V_{DD}=3.3V +/-5%; loads from Intel CK408B spec, Rev 1.1 (unless otherwise specified)

PARAMETER	SYMBOL	CONDITIONS	MIN	TYP	MAX	UNITS
Current Source Output Impedance ¹	Z _{O2A}	V _O = V _x	3000			Ω
Output High Voltage	V _{OH2A}	V _R = 475Ω ±1%; I _{REF} = 2.32 mA; I _{OH} = 6*I _{REF}		0.71	1.2	V
Output High Current	I _{OH32A}			-13.92		mA
Rise Time ¹	t _{r2A}	V _{OL} = -0.35V, V _{OH} = 0.35V	175	220	467	ps
Fall Time ¹	t _{f2A}	V _{OH} = 0.35V, V _{OL} = -0.35V	175	230	467	ps
Differential Crossover Voltage ¹	V _{2A}	R _s = 33.2Ω, R _p = 63.4Ω to gnd, R _{T-C} = 475Ω	510	700	900	mV
Duty Cycle ¹	d _{i2A}	V _T = crossing point	45	49	55	%
Skew, CPUT,C to CPU ¹	t _{sk2A}	V _T (CPU) = crossing point, V _T (PCI) = 1.25 V 100 MHz		250	300	ps
		133 MHz		170	200	
Skew, CPUT,C to PCI ¹	t _{sk2A1}	V _T (CPU) = crossing point, V _T (PCI) = 1.5 V	2	3.2	4	ns
Jitter, Cycle to cycle ¹	t _{jcy-cyc2A}	V _T = crossing point CPU,SD = 100MHz		50	200	ps

¹Guaranteed by design, not 100% tested in production.

Electrical Characteristics - CPUCLK(1:0)

T_A = 0 - 70°C; V_{DD}=3.3V +/-5%; C_L = 10-20 pF (unless otherwise specified)

PARAMETER	SYMBOL	CONDITIONS	MIN	TYP	MAX	UNITS
Output Impedance ¹	R _{DSP2B}	V _O = V _{DD} *(0.5)	13.5		45	Ω
Output Impedance ¹	R _{DSN2B}	V _O = V _{DD} *(0.5)	13.5		45	
Output High Voltage	V _{OH2B}	I _{OH} = -1 mA	2			V
Output Low Voltage	V _{OL2B}	I _{OL} = 1 mA			0.4	
Output High Current	I _{OH2B}	V _{OH@MIN} = 1.0 V, V _{OH@MAX} = 2.375 V	-27		27	V
Output Low Current	I _{OL2B}	V _{OL@MIN} = 1.2 V, V _{OL@MIN} = 0.3 V	27		30	
Rise Time ¹	t _{r2B}	V _{OL} = 0.4V, V _{OH} = 2.0V	0.4	0.7	1.6	ns
Fall Time ¹	t _{f2B}			V _{OH} = 2.0V V _{OL} = 0.4V		
Duty Cycle ¹	d _{i2B}	V _T = 50% 100MHz 133 MHz	45	50	55	%
				54		
Skew, CPU to CPU ¹	t _{sk2B}	V _T = 1.25 V		60	175	ps
Skew, CPU to PCI ¹	t _{sk2B1}	V _T (CPU) = 1.25 V, V _T (PCI) = 1.5 V	2	3.2	4	ns
Jitter, Cycle to cycle ¹	t _{jcy-cyc2B}	V _T = 1.25V CPU,SD = 100MHz CPU,SD = 133 MHz CPU = 100, SD = 133 MHz		140	250	ps
				100	250	
				220	275	

¹Guaranteed by design, not 100% tested in production.

Electrical Characteristics - PCICLK

$T_A = 0 - 70^\circ\text{C}$; $V_{DD} = 3.3\text{V} \pm 5\%$; $C_L = 10\text{-}30\text{ pF}$ (unless otherwise specified)

PARAMETER	SYMBOL	CONDITIONS	MIN	TYP	MAX	UNITS
Output Frequency	F_{O1}			33.33		MHz
Output Impedance	R_{DSP1}^1	$V_O = V_{DD}^*(0.5)$	12		55	Ω
Output High Voltage	V_{OH1}^1	$I_{OH} = -1\text{ mA}$	2.4			V
Output Low Voltage	V_{OL1}^1	$I_{OL} = 1\text{ mA}$			0.55	V
Output High Current	I_{OH1}^1	$V_{OH@MIN} = 1.0\text{ V}$, $V_{OH@MAX} = 3.135\text{ V}$	-33		-33	mA
Output Low Current	I_{OL1}^1	$V_{OL@MIN} = 1.95\text{ V}$, $V_{OL@MAX} = 0.4\text{ V}$	30		38	mA
Rise Time	t_{r1}^1	$V_{OL} = 0.4\text{ V}$, $V_{OH} = 2.4\text{ V}$	0.5	2.4	2.5	ns
Fall Time	t_{f1}^1	$V_{OH} = 2.4\text{ V}$, $V_{OL} = 0.4\text{ V}$	0.5	2.25	2.5	ns
Duty Cycle	d_{t1}^1	$V_T = 1.5\text{ V}$	45	53	55	%
Skew	t_{sk1}^1	$V_T = 1.5\text{ V}$		220	500	ps
Jitter, cycle to cycle	$t_{jyc-cyc}^1$	$V_T = 1.5\text{ V}$		300	450	ps

¹Guaranteed by design, not 100% tested in production.

Electrical Characteristics - 48MHz, 24_48MHz

$T_A = 0 - 70^\circ\text{C}$; $V_{DD} = 3.3\text{V} \pm 5\%$; $C_L = 10\text{-}20\text{ pF}$ (unless otherwise specified)

PARAMETER	SYMBOL	CONDITIONS	MIN	TYP	MAX	UNITS
Output Frequency	F_{O3}^1			48		MHz
Output Impedance	R_{DSP3}^1	$V_O = V_{DD}^*(0.5)$	12		55	Ω
Output High Voltage	V_{OH3}^1	$I_{OH} = -1\text{ mA}$	2.4			V
Output Low Voltage	V_{OL3}^1	$I_{OL} = 1\text{ mA}$			0.55	V
Output High Current	I_{OH3}^1	$V_{OH@MIN} = 1.0\text{ V}$, $V_{OH@MAX} = 3.135\text{ V}$	-29		-23	mA
Output Low Current	I_{OL3}^1	$V_{OL@MIN} = 1.95\text{ V}$, $V_{OL@MAX} = 0.4\text{ V}$	29		27	mA
Rise Time	t_{r3A}^1	$V_{OL} = 0.4\text{ V}$, $V_{OH} = 2.4\text{ V}$	1	1.1	2	ns
Fall Time	t_{f3B}^1	$V_{OH} = 2.4\text{ V}$, $V_{OL} = 0.4\text{ V}$	1	1.25	2	ns
Duty Cycle	d_{t3A}^1	$V_T = 1.5\text{ V}$	45	52	55	%
Jitter, cycle-to-cycle	$t_{jyc-cyc3}^1$	$V_T = 1.5\text{ V}$		200	350	ps

¹Guaranteed by design, not 100% tested in production.

Electrical Characteristics - SDRAM

$T_A = 0 - 70^\circ\text{C}$; $V_{DD}=3.3\text{V} \pm 5\%$; $C_L = 10\text{-}30\text{ pF}$ (unless otherwise specified)

PARAMETER	SYMBOL	CONDITIONS	MIN	TYP	MAX	UNITS
Output Impedance ¹	R_{DSP5}	$V_O=V_{DD}*(0.5)$	10		24	Ω
Output Impedance ¹	R_{DSN5}	$V_O=V_{DD}*(0.5)$	10		24	Ω
Output High Voltage	V_{OH5}	$I_{OH} = -1\text{ mA}$	2.4			V
Output Low Voltage	V_{OL5}	$I_{OL} = 1\text{ mA}$			0.4	V
Output High Current	I_{OH5}	$V_{OH@MIN} = 2\text{ V}$			-46	mA
		$V_{OH@MAX} = 3.135\text{V}$	-54			
Output Low Current	I_{OL5}	$V_{OL@MIN} = 1\text{ V}$	54			mA
		$V_{OL@MAX} = 0.4\text{V}$			53	
Rise Time	t_{r5}^1	$V_{OL} = 0.4\text{ V}, V_{OH} = 2.4\text{ V}$	0.4	1.1	1.6	ns
Fall Time	t_{f5}^1	$V_{OH} = 2.4\text{ V}, V_{OL} = 0.4\text{ V}$	0.4	0.75	1.6	ns
Duty Cycle	d_{t5}^1	$V_T = 1.5\text{ V}$	45	50	55	%
Skew	t_{sk5}^1	$V_T = 1.5\text{ V}$		30	250	ps
Propagation delay SDRAM_IN to SDRAM	t_{pdel5}^1	$V_T = 1.5\text{ V}$		2.95	4	ns

¹Guaranteed by design, not 100% tested in production.

Electrical Characteristics - REF

$T_A = 0 - 70^\circ\text{C}$; $V_{DD}=3.3\text{V} \pm 5\%$; $C_L = 10\text{-}20\text{ pF}$ (unless otherwise specified)

PARAMETER	SYMBOL	CONDITIONS	MIN	TYP	MAX	UNITS
Output Frequency	F_{O4}^1			14.318		MHz
Output Impedance	R_{DSP4}^1	$V_O = V_{DD}*(0.5)$	20		60	Ω
Output High Voltage	V_{OH4}^1	$I_{OH} = -1\text{ mA}$	2.4			V
Output Low Voltage	V_{OL4}^1	$I_{OL} = 1\text{ mA}$			0.4	V
Output High Current	I_{OH4}^1	$V_{OH@MIN} = 1.0\text{ V}, V_{OH@MAX} = 3.135\text{ V}$	-29		-23	mA
Output Low Current	I_{OL4}^1	$V_{OL@MIN} = 1.95\text{ V}, V_{OL@MAX} = 0.4\text{ V}$	29		27	mA
Rise Time	t_{r4}^1	$V_{OL} = 0.4\text{ V}, V_{OH} = 2.4\text{ V}$	1	1.85	4	ns
Fall Time	t_{f4}^1	$V_{OH} = 2.4\text{ V}, V_{OL} = 0.4\text{ V}$	1	1.95	4	ns
Duty Cycle	d_{t1}^1	$V_T = 1.5\text{ V}$	45	55.7	56	%
Jitter, cycle-to-cycle	$t_{jyc-cyc4}^1$	$V_T = 1.5\text{ V}$		365	550	ps

¹Guaranteed by design, not 100% tested in production.

Shared Pin Operation - Input/Output Pins

The I/O pins designated by (input/output) serve as dual signal functions to the device. During initial power-up, they act as input pins. The logic level (voltage) that is present on these pins at this time is read and stored into a 5-bit internal data latch. At the end of Power-On reset, (see AC characteristics for timing values), the device changes the mode of operations for these pins to an output function. In this mode the pins produce the specified buffered clocks to external loads.

To program (load) the internal configuration register for these pins, a resistor is connected to either the VDD (logic 1) power supply or the GND (logic 0) voltage potential. A 10 Kiloohm (10K) resistor is used to provide both the solid CMOS programming voltage needed during the power-up programming period and to provide an insignificant load on the output clock during the subsequent operating period.

Figure 1 shows a means of implementing this function when a switch or 2 pin header is used. With no jumper is installed the pin will be pulled high. With the jumper in place the pin will be pulled low. If programmability is not necessary, than only a single resistor is necessary. The programming resistors should be located close to the series termination resistor to minimize the current loop area. It is more important to locate the series termination resistor close to the driver than the programming resistor.

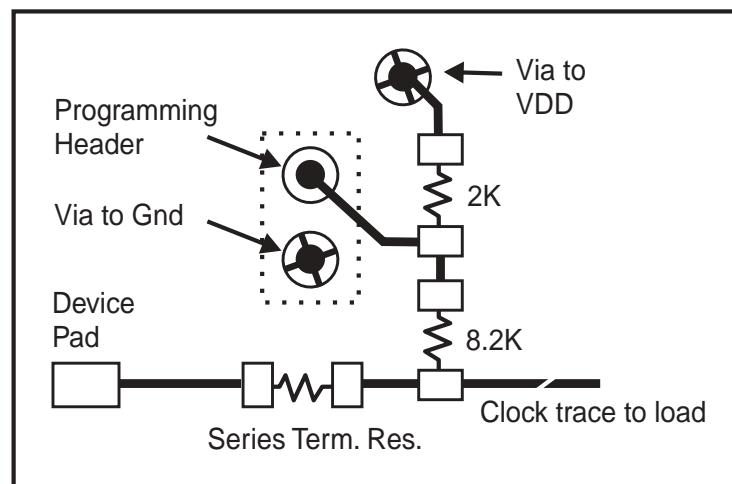
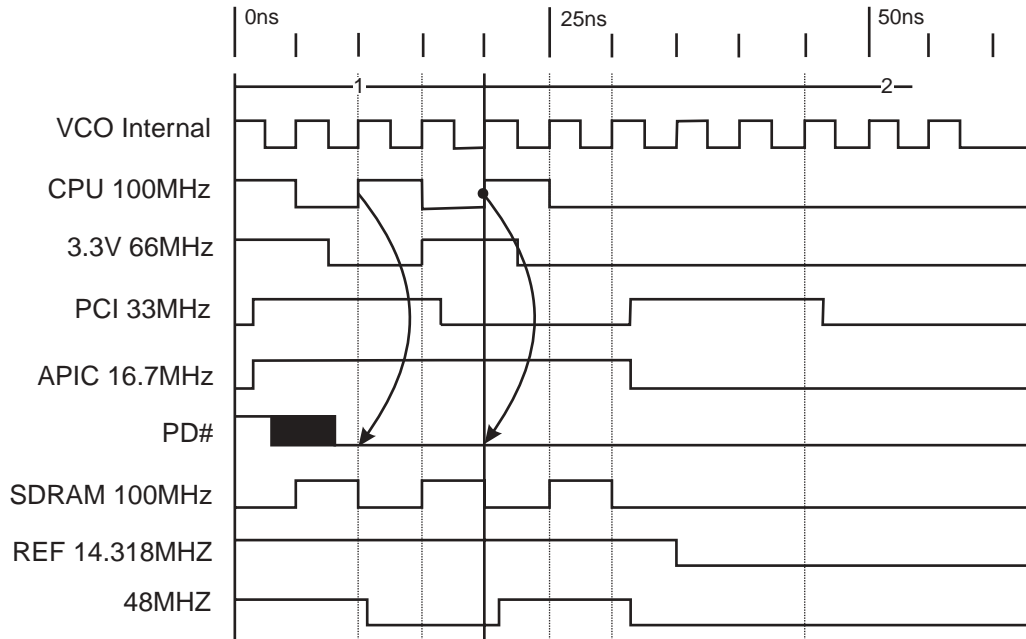

Fig. 1

Power Down Waveform



Note

1. After PD# is sampled active (Low) for 2 consecutive rising edges of CPUCLKs, all the output clocks are driven Low on their next High to Low transition.
2. Power-up latency <3ms.
3. Waveform shown for 100MHz

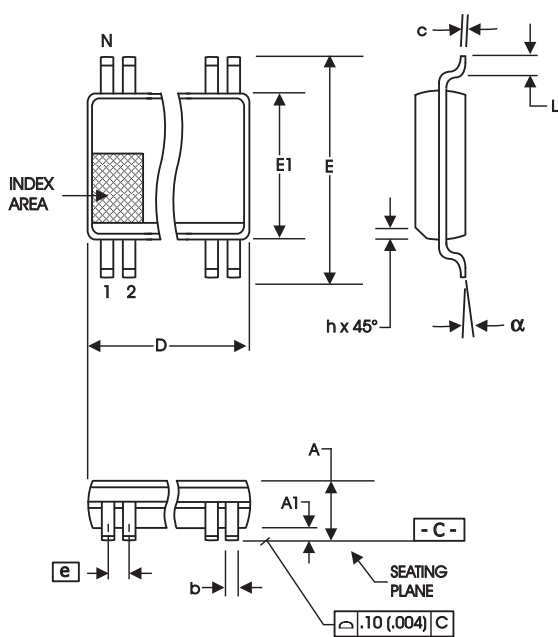

300 mil SSOP Package

SYMBOL	In Millimeters COMMON DIMENSIONS		In Inches COMMON DIMENSIONS	
	MIN	MAX	MIN	MAX
A	2.41	2.80	.095	.110
A1	0.20	0.40	.008	.016
b	0.20	0.34	.008	.0135
c	0.13	0.25	.005	.010
D	SEE VARIATIONS		SEE VARIATIONS	
E	10.03	10.68	.395	.420
E1	7.40	7.60	.291	.299
e	0.635 BASIC		0.025 BASIC	
h	0.38	0.64	.015	.025
L	0.50	1.02	.020	.040
N	SEE VARIATIONS		SEE VARIATIONS	
alpha	0°	8°	0°	8°

VARIATIONS

N	D mm.		D (inch)	
	MIN	MAX	MIN	MAX
48	15.75	16.00	.620	.630

Reference Doc.: JEDEC Publication 95, MO-118

10-0034

Ordering Information

ICS950602yFT

Example:

ICS XXXX y F - T

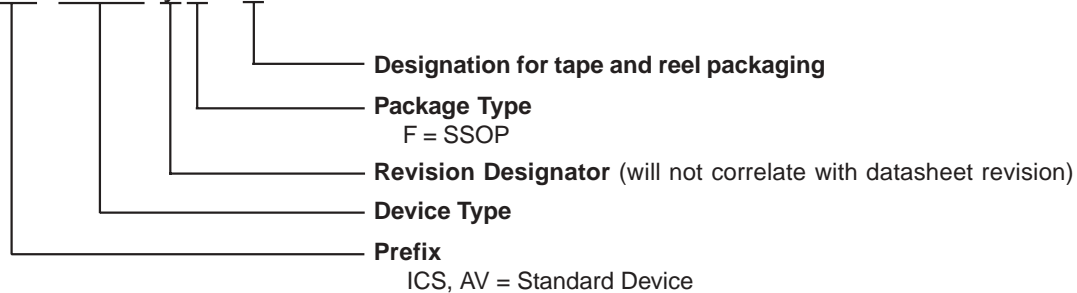

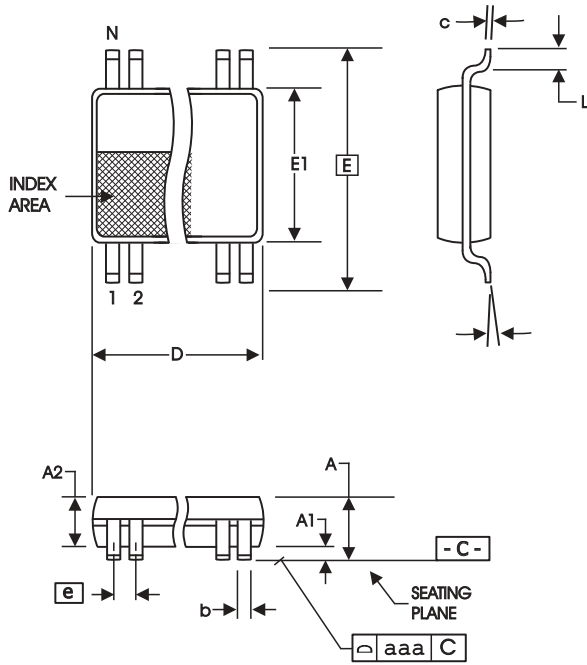

6.10 mm. Body, 0.50 mm. pitch TSSOP
(240 mil) (20 mil)

SYMBOL	In Millimeters		In Inches	
	COMMON DIMENSIONS	COMMON DIMENSIONS	COMMON DIMENSIONS	COMMON DIMENSIONS
A	--	1.20	--	.047
A1	0.05	0.15	.002	.006
A2	0.80	1.05	.032	.041
b	0.17	0.27	.007	.011
c	0.09	0.20	.0035	.008
D	SEE VARIATIONS		SEE VARIATIONS	
E	8.10 BASIC		0.319 BASIC	
E1	6.00	6.20	.236	.244
e	0.50 BASIC		0.020 BASIC	
L	0.45	0.75	.018	.030
N	SEE VARIATIONS		SEE VARIATIONS	
α	0°	8°	0°	8°
aaa	--	0.10	--	.004

VARIATIONS

N	D mm.		D (inch)	
	MIN	MAX	MIN	MAX
48	12.40	12.60	.488	.496

Reference Doc.: JEDEC Publication 95, MO-153

10-0039

Ordering Information

ICS950602yGT

Example:

ICS XXXX y G - T

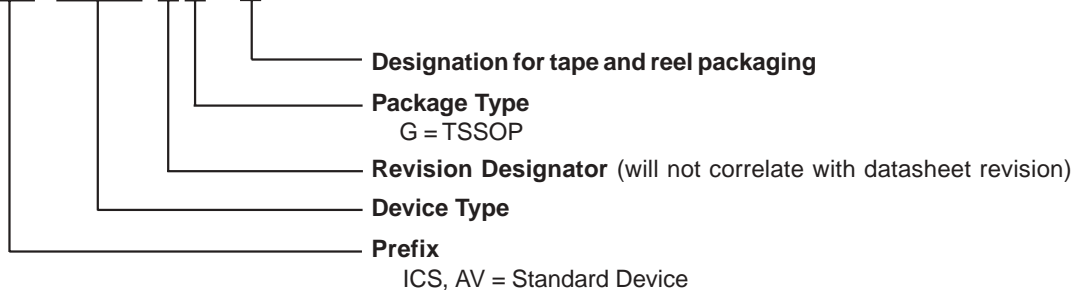

Looking for pricing, stock, or lifecycle information?

Click below to explore more details on WIN SOURCE:

-  [View ICS950602CGLF on WIN SOURCE](#)
-  [IDT, Integrated Device Technology Inc Information](#)

Optimize Your Supply Chain with WIN SOURCE Solutions

-  Global Sourcing Solution
-  Obsolete Management
-  Cost Control Management
-  Shortage Management
-  Alternative Solution
-  Excess Inventory Management