



**THE DATASHEET OF  
87946AYILFT**



**PRODUCT DISCONTINUATION NOTICE - LAST TIME BUY EXPIRES MAY 6, 2017**

**General Description**

The 87946I is a low skew, ÷1, ÷2 LVCMOS Fanout Buffer. The 87946I has two selectable single ended clock inputs. The 87946I has two selectable single ended clock inputs. The single ended clock inputs accept LVCMOS or LVTTL input levels. The low impedance LVCMOS outputs are designed to drive 50Ω series or parallel terminated transmission lines. The effective fanout can be increased from 10 to 20 by utilizing the ability of the outputs to drive two series terminated lines.

The divide select inputs, DIV\_SELx, control the output frequency of each bank. The outputs can be utilized in the ÷1, ÷2 or a combination of ÷1 and ÷2 modes. The master reset input, MR/nOE, resets the internal frequency dividers and also controls the active and high impedance states of all outputs.

The 87946I is characterized at 3.3V core/3.3V output. Guaranteed output and part-to-part skew characteristics make the 87946I ideal for those clock distribution applications demanding well defined performance and repeatability.

**Features**

- Ten single-ended LVCMOS outputs, 7Ω typical output impedance
- Selectable CLK0 and CLK1 LVCMOS clock inputs
- CLK0 and CLK1 can accept the following input levels: LVCMOS and LVTTL
- Maximum input/output frequency: 150MHz
- Output skew: 350ps (maximum)
- 3.3V input, 3.3V outputs
- -40°C to 85°C ambient operating temperature
- Available in lead-free (RoHS 6) package
- **For drop-in replacement use 87946I-147**

**Block Diagram**

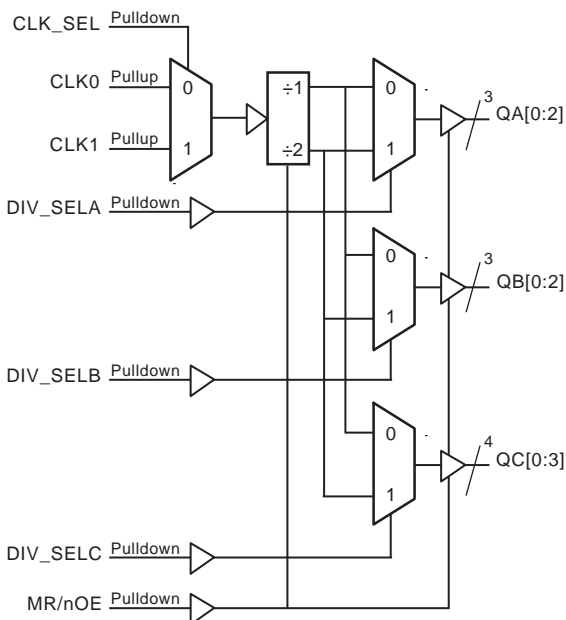

**Pin Assignment**

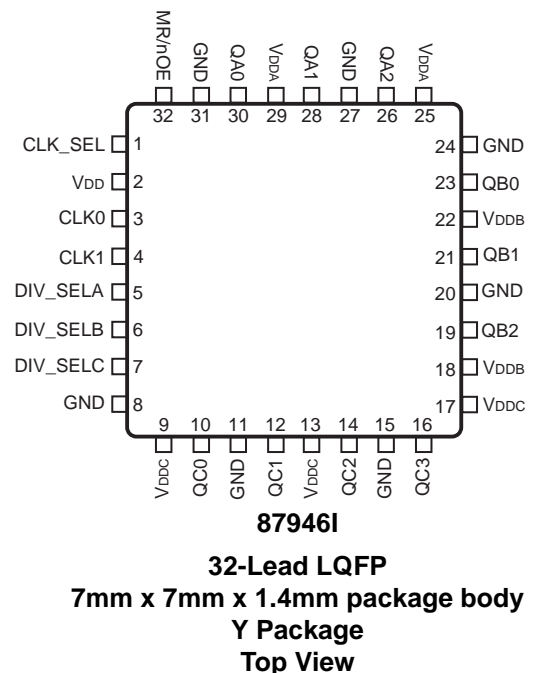

**Table 1. Pin Descriptions**

Number	Name	Type		Description
1	CLK_SEL	Input	Pulldown	Clock select input. When HIGH, selects CLK1. When LOW, selects CLK0. LVCMOS / LVTTTL interface levels.
2	V <sub>DD</sub>	Power		Positive supply pin.
3, 4	CLK0, CLK1	Input	Pullup	LVCMOS/LVTTTL clock inputs.
5	DIV_SELA	Input	Pulldown	Controls frequency division for Bank A outputs. LVCMOS/LVTTTL interface levels.
6	DIV_SELB	Input	Pulldown	Controls frequency division for Bank B outputs. LVCMOS/LVTTTL interface levels.
7	DIV_SELC	Input	Pulldown	Controls frequency division for Bank C outputs. LVCMOS/LVTTTL interface levels.
8, 11, 15, 20, 24, 27, 31	GND	Power		Power supply ground.
9, 13, 17	V <sub>DDC</sub>	Power		Positive supply pins for Bank C outputs.
10, 12, 14, 16	QC0, QC1, QC2, QC3	Output		Bank C clock outputs. LVCMOS/LVTTTL interface levels. 7Ω typical output impedance.
18, 22	V <sub>DDB</sub>	Power		Positive supply pins for Bank B outputs.
19, 21, 23	QB2, QB1, QB0	Output		Bank B clock outputs. LVCMOS/LVTTTL interface levels. 7Ω typical output impedance.
25, 29	V <sub>DDA</sub>	Power		Positive supply pins for Bank A outputs.
26, 28, 30	QA2, QA1, QA0	Output		Bank A clock outputs. LVCMOS/LVTTTL interface levels. 7Ω typical output impedance.
32	MR/nOE	Input	Pulldown	Master reset and output enable. When LOW, output drivers are enabled. When HIGH, output drivers are in High-Impedance and dividers are reset. LVCMOS / LVTTTL interface levels.

NOTE: Pullup and Pulldown refer to internal input resistors. See Table 2, *Pin Characteristics*, for typical values.

**Table 2. Pin Characteristics**

Symbol	Parameter	Test Conditions	Minimum	Typical	Maximum	Units
C <sub>IN</sub>	Input Capacitance				4	pF
R <sub>PULLUP</sub>	Input Pullup Resistor			51		kΩ
R <sub>PULLDOWN</sub>	Input Pulldown Resistor			51		kΩ
C <sub>PD</sub>	Power Dissipation Capacitance (per output); NOTE 1	V <sub>DD</sub> , V <sub>DDX</sub> = 3.6V		25		pF
R <sub>OUT</sub>	Output Impedance			7		Ω

NOTE 1: V<sub>DDX</sub> denotes V<sub>DDA</sub>, V<sub>DDB</sub>, V<sub>DDC</sub>.

**Table 3. Function Table**

Inputs				Outputs		
MR/nOE	DIV_SELA	DIV_SELB	DIV_SELC	QA0:QA2	QB0:QB2	QC0:QC3
1	X	X	X	High-Impedance	High-Impedance	High-Impedance
0	0	X	X	$f_{IN}/1$	Active	Active
0	1	X	X	$f_{IN}/2$	Active	Active
0	X	0	X	Active	$f_{IN}/1$	Active
0	X	1	X	Active	$f_{IN}/2$	Active
0	X	X	0	Active	Active	$f_{IN}/1$
0	X	X	1	Active	Active	$f_{IN}/2$

## Absolute Maximum Ratings

NOTE: Stresses beyond those listed under *Absolute Maximum Ratings* may cause permanent damage to the device. These ratings are stress specifications only. Functional operation of product at these conditions or any conditions beyond those listed in the *DC Characteristics* or *AC Characteristics* is not implied. Exposure to absolute maximum rating conditions for extended periods may affect product reliability.

Item	Rating
Supply Voltage, $V_{DD}$	4.6V
Inputs, $V_{DD}$	-0.5V to $V_{DD} + 0.5V$
Outputs, $V_{DD}$	-0.5V to $V_{DDX} + 0.5V$
Package Thermal Impedance, $\theta_{JA}$	47.9°C/W (0 lfpm)
Storage Temperature, $T_{STG}$	-65°C to 150°C

## DC Electrical Characteristics

**Table 4A. Power Supply DC Characteristics,  $V_{DD} = V_{DDX} = 3.3V \pm 0.3V$ ,  $T_A = -40^\circ C$  to  $85^\circ C$** 

Symbol	Parameter	Test Conditions	Minimum	Typical	Maximum	Units
$V_{DD}$	Positive Supply Voltage		3.0	3.3	3.6	V
$V_{DDX}$	Output Supply Voltage; NOTE 1		3.0	3.3	3.6	V
$I_{DD}$	Power Supply Current				85	mA

NOTE 1:  $V_{DDX}$  denotes  $V_{DDA}$ ,  $V_{DDB}$ ,  $V_{DDC}$ .

**Table 4B. LVCMOS/LVTTL DC Characteristics,  $V_{DD} = V_{DDX} = 3.3V \pm 0.3V$ ,  $T_A = -40^{\circ}C$  to  $85^{\circ}C$** 

Symbol	Parameter	Test Conditions	Minimum	Typical	Maximum	Units
$V_{IH}$	Input High Voltage	DIV_SELA, DIV_SELB, DIV_SEL, CLK_SEL, MR/nOE	2		$V_{DD} + 0.3$	V
		CLK0, CLK1	2		$V_{DD} + 0.3$	V
$V_{IL}$	Input Low Voltage	DIV_SELA, DIV_SELB, DIV_SEL, CLK_SEL, MR/nOE	-0.3		0.8	V
		CLK0, CLK1	-0.3		1.3	V
$I_{IH}$	Input High Current	DIV_SELA, DIV_SELB, DIV_SEL, CLK_SEL, MR/nOE	$V_{DD} = V_{IN} = 3.6V$		120	$\mu A$
		CLK0, CLK1	$V_{DD} = V_{IN} = 3.6V$		5	$\mu A$
$I_{IL}$	Input Low Current	DIV_SELA, DIV_SELB, DIV_SEL, CLK_SEL, MR/nOE	$V_{DD} = 3.6V, V_{IN} = 0V$	-5		$\mu A$
		CLK0, CLK1	$V_{DD} = 3.6V, V_{IN} = 0V$	-120		$\mu A$
$V_{OH}$	Output High Voltage	$I_{OH} = -20mA$	2.5			V
$V_{OL}$	Output Low Voltage	$I_{OH} = 20mA$			0.4	V

## AC Electrical Characteristics

**Table 5. AC Characteristics,  $V_{DD} = V_{DDX} = 3.3V \pm 0.3V$ ,  $T_A = -40^{\circ}C$  to  $85^{\circ}C$**

Symbol	Parameter	Test Conditions	Minimum	Typical	Maximum	Units
$f_{IN}$	Input Frequency				150	MHz
$t_{PLH}$	Propagation Delay Low to High; NOTE 1		2		12	ns
$t_{PHL}$	Propagation Delay High to Low; NOTE 1		2.0		11.5	ns
$t_{sk(o)}$	Output Skew; NOTE 2, 6				350	ps
$t_{sk(w)}$	Multiple Frequency Skew; NOTE 3, 6	$f_{MAX} < 100MHz$			350	ps
		$f_{MAX} > 100MHz$			450	ps
$t_{sk(pp)}$	Part-to-Part Skew; NOTE 4, 6				4.5	ns
$t_R / t_F$	Output Rise/Fall Time; NOTE 5	0.8V to 2.0V	0.1		1.0	ns
$t_{EN}$	Output Enable Time; NOTE 5				11	ns
$t_{DIS}$	Output Disable Time; NOTE 5				11	ns

NOTE: Electrical parameters are guaranteed over the specified ambient operating temperature range, which is established when the device is mounted in a test socket with maintained transverse airflow greater than 500 lfpm. The device will meet specifications after thermal equilibrium has been reached under these conditions.

NOTE:  $V_{DDX}$  denotes  $V_{DDA}$ ,  $V_{DDB}$ ,  $V_{DDC}$ .

NOTE 1: Measured from  $V_{DD}/2$  of the input to  $V_{DDX}/2$  of the output.

NOTE 2: Defined as skew between outputs at the same supply voltage and with equal load conditions. Measured at  $V_{DDX}/2$ .

NOTE 3: Defined as skew across banks of outputs operating at different frequencies with the same supply voltage and equal load conditions.

NOTE 4: Defined as skew between outputs on different devices operating at the same supply voltage, same frequency and with equal load conditions. Using the same type of inputs on each device, the outputs are measured at  $V_{DDX}/2$ .

NOTE 5: These parameters are guaranteed by characterization. Not tested in production.

NOTE 6: This parameter is defined in accordance with JEDEC Standard 65.

## Parameter Measurement Information

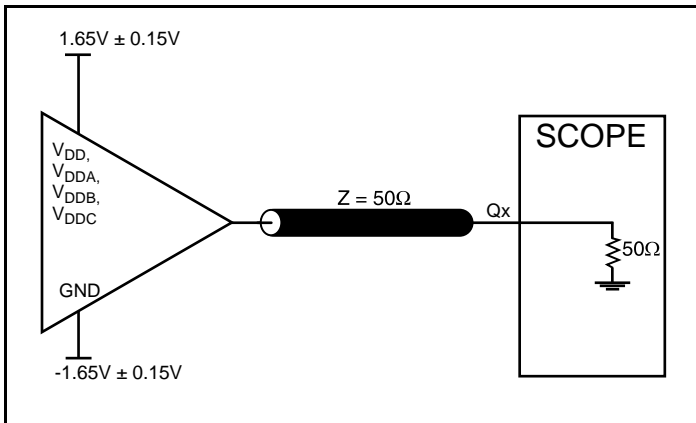

3.3V Output Load AC Test Circuit

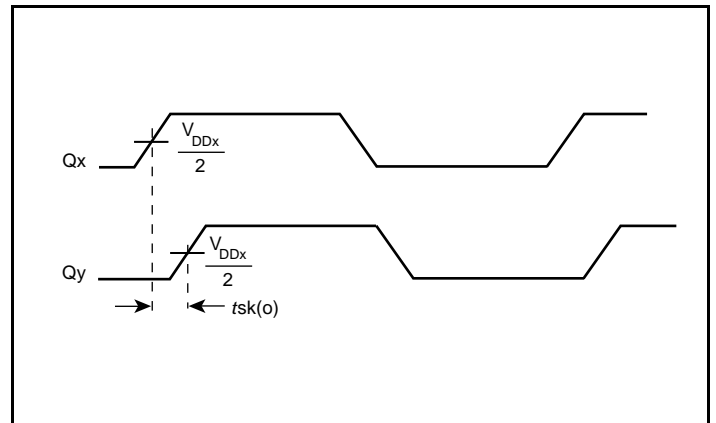

Output Skew

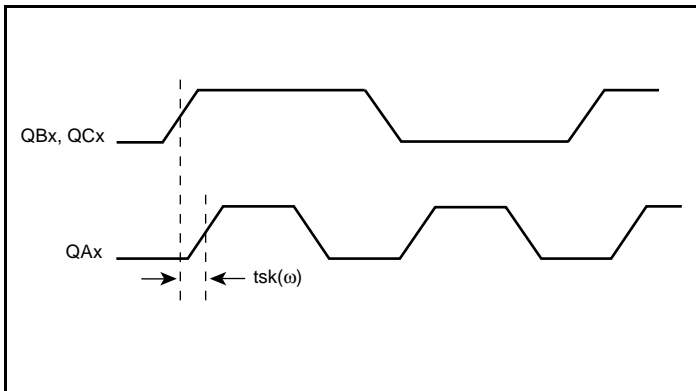

Multiple Frequency Skew

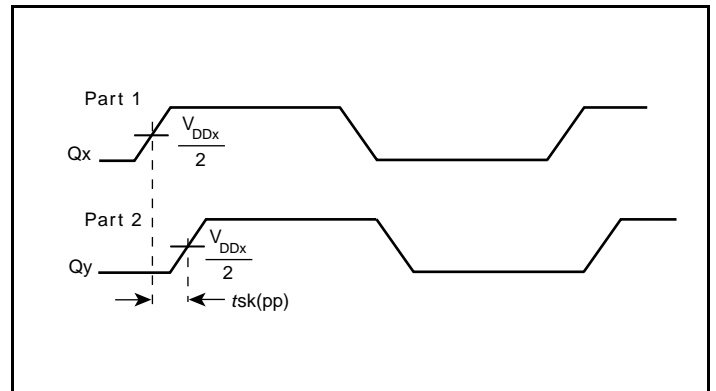

Part-to-Part Skew

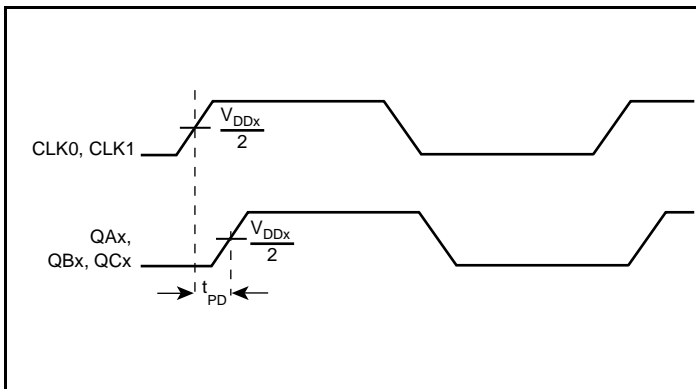

Propagation Delay

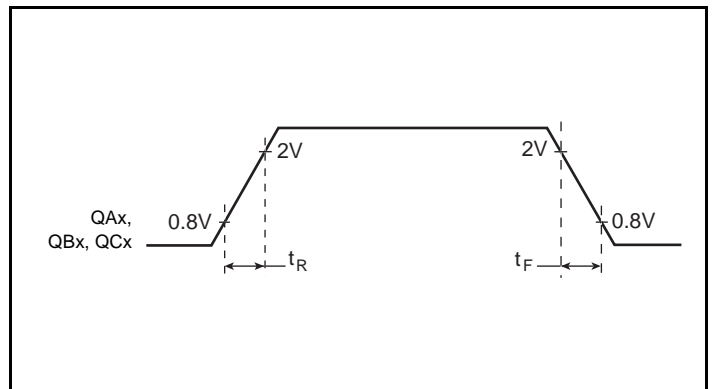

Output Rise/Fall Time

## Application Information

### Recommendations for Unused Input and Output Pins

#### Inputs:

##### CLK Inputs

For applications not requiring the use of a clock input, it can be left floating. Though not required, but for additional protection, a 1k $\Omega$  resistor can be tied from the CLK input to ground.

##### LVC MOS Control Inputs

All control pins have internal pullups or pulldowns; additional resistance is not required but can be added for additional protection. A 1k $\Omega$  resistor can be used.

#### Outputs:

##### LVC MOS Outputs

All unused LVC MOS output can be left floating. There should be no trace attached.

## Reliability Information

**Table 6.  $\theta_{JA}$  vs. Air Flow Table**

$\theta_{JA}$ vs. Air Flow (Linear Feet per Minute)			
Linear Feet per Minute	0	200	500
Single-Layer PCB, JEDEC Standard Test Boards	67.8°C/W	55.9°C/W	50.1°C/W
Multi-Layer PCB, JEDEC Standard Test Boards	47.9°C/W	42.1°C/W	39.4°C/W

NOTE: Most modern PCB designs use multi-layered boards. The data in the second row pertains to most designs.

### Transistor Count

The transistor count for 87946I is: 1204

# Package Outline and Package Dimensions

## Package Outline - Y Suffix for 32 Lead LQFP

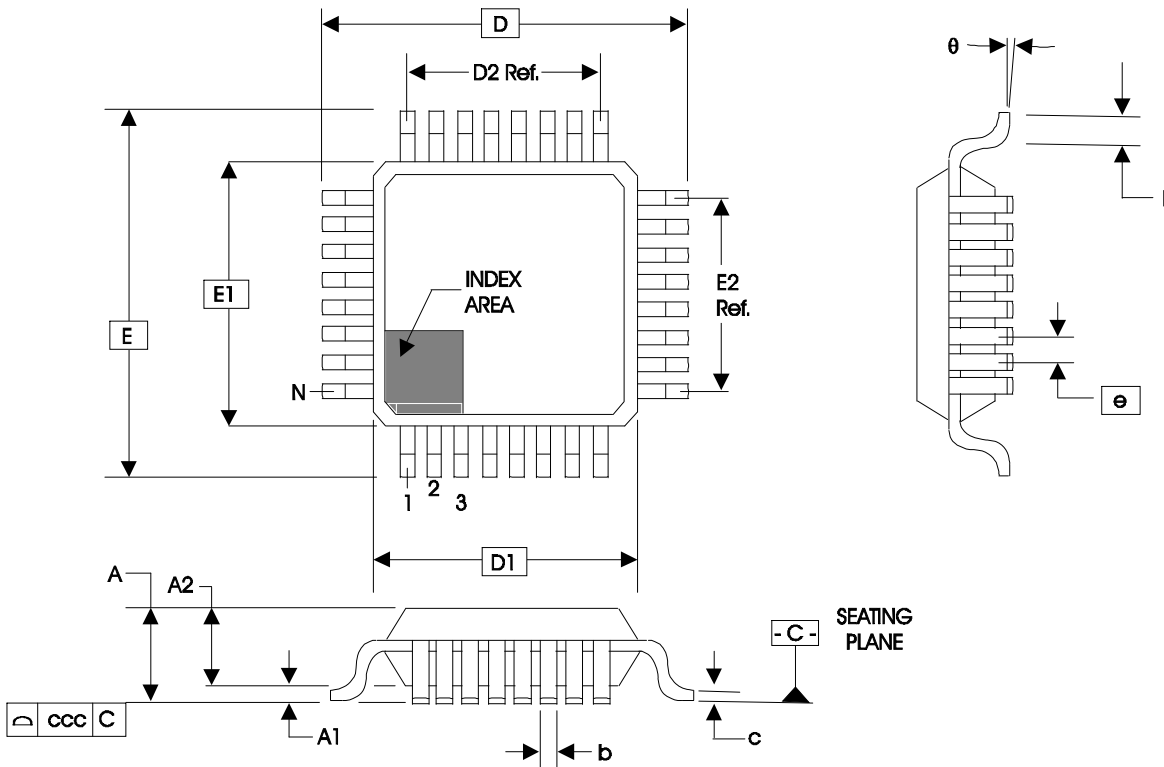

Table 7. Package Dimensions for 32 Lead LQFP

JEDEC Variation: All Dimensions in Millimeters			
Symbol	Minimum	Nominal	Maximum
N	32		
A			1.60
A1	0.05		0.15
A2	1.35	1.40	1.45
b	0.30	0.37	0.45
c	0.09		0.20
D & E	9.00 Basic		
D1 & E1	7.00 Basic		
D2 & E2	5.60 Ref.		
e	0.80 Basic		
L	0.45	0.60	0.75
θ	0°		7°
ccc			0.10

Reference Document: JEDEC Publication 95, MS-026

## Ordering Information

**Table 8. Ordering Information**

Part/Order Number	Marking	Package	Shipping Packaging	Temperature
87946AYILF	ICS87946AYIL	"Lead-Free" 32 Lead LQFP	Tray	-40°C to 85°C
87946AYILFT	ICS87946AYIL	"Lead-Free" 32 Lead LQFP	Tape & Reel	-40°C to 85°C

## Revision History Sheet

Rev	Table	Page	Description of Change	Date
A	T1	1 2 6	Features section added <i>Max Input/Output frequency</i> bullet. Revised MR/nOE description. Revised Output Rise & Fall time diagram	8/14/02
B	T5	4	AC Characteristics Table changed: (CLK0, CLK1) $TP_{LH}$ from 6.0ns max. to 12.0ns max, deleted typical value (CLK0, CLK1) $TP_{HL}$ from 6.0ns max. to 11.5ns max, deleted typical value	10/22/02
B	T5  T8	5 6 7 8 9	AC Characteristics Table - changed symbol $f_{OUT}$ to $f_{IN}$ . Moved 150MHz min. to max. column. Added Thermal Note. Corrected NOTE 2. Updated parameter Measurement Information section. Added Recommendations for Unused Input and Output Pins section. Updated Package Outline drawing. Ordering Information Table - deleted ICS prefix from Part/Order Number column. Added lead-free marking.	3/17/10
B		1	Deleted HiperClocks logo from General Description. Update Header / Footer of the datasheet.	6/22/12
B	T8	9	Ordering Information - removed leaded devices, PDN CQ-13-02. Updated data sheet format.	2/18/15
B	T8	9	Ordering Information - Deleted LF note below table. Product Discontinuation Notice - Last time buy expires May 6, 2017. PDN CQ-16-01 Updated header and footer.	6/28/16
C		1	Corrected datasheet title. Corrected <i>General Description</i> , first sentence from <i>Clock Generator</i> to <i>Fanout Buffer</i> .	9/20/16



Corporate Headquarters  
6024 Silver Creek Valley Road  
San Jose, CA 95138 USA  
[www.IDT.com](http://www.IDT.com)

Sales  
1-800-345-7015 or 408-284-8200  
Fax: 408-284-2775  
[www.IDT.com/go/sales](http://www.IDT.com/go/sales)

Tech Support  
[www.idt.com/go/support](http://www.idt.com/go/support)

DISCLAIMER Integrated Device Technology, Inc. (IDT) reserves the right to modify the products and/or specifications described herein at any time, without notice, at IDT's sole discretion. Performance specifications and operating parameters of the described products are determined in an independent state and are not guaranteed to perform the same way when installed in customer products. The information contained herein is provided without representation or warranty of any kind, whether express or implied, including, but not limited to, the suitability of IDT's products for any particular purpose, an implied warranty of merchantability, or non-infringement of the intellectual property rights of others. This document is presented only as a guide and does not convey any license under intellectual property rights of IDT or any third parties.

IDT's products are not intended for use in applications involving extreme environmental conditions or in life support systems or similar devices where the failure or malfunction of an IDT product can be reasonably expected to significantly affect the health or safety of users. Anyone using an IDT product in such a manner does so at their own risk, absent an express, written agreement by IDT.

Integrated Device Technology, IDT and the IDT logo are trademarks or registered trademarks of IDT and its subsidiaries in the United States and other countries. Other trademarks used herein are the property of IDT or their respective third party owners. For datasheet type definitions and a glossary of common terms, visit [www.idt.com/go/glossary](http://www.idt.com/go/glossary). Integrated Device Technology, Inc. All rights reserved.

## Looking for pricing, stock, or lifecycle information?

Click below to explore more details on WIN SOURCE:

- ⊖ [View 87946AYILFT on WIN SOURCE](#)
- ⊖ [IDT, Integrated Device Technology Inc Information](#)

## Optimize Your Supply Chain with WIN SOURCE Solutions

- ✓ Global Sourcing Solution
- ✓ Obsolete Management
- ✓ Cost Control Management
- ✓ Shortage Management
- ✓ Alternative Solution
- ✓ Excess Inventory Management