



**THE DATASHEET OF  
ICM7245BIM44ZT**



## ICM7245

8-Character, 16-Segment, Microprocessor Compatible, LED Display Decoder Driver

FN8587  
Rev 0.00  
October 29, 2013

The ICM7245 is an 8-character, alphanumeric display driver and controller which provides all the circuitry required to interface a microprocessor or digital system to a 16-segment display with internal pull-up resistors. It is primarily intended for use in microprocessor systems, where it minimizes hardware and software overhead. Incorporated on-chip are a 64-character ASCII decoder, 8x6 memory, high power character and segment drivers, and the multiplex scan circuitry.

6-bit ASCII data to be displayed is written into the memory directly from the microprocessor data bus. Data location depends upon the selection of either **Sequential** (MODE = 1) or **Random** access mode (MODE = 0). In the **Sequential Access** mode the first entry is stored in the lowest location and displayed in the "left-most" character position. Each subsequent entry is automatically stored in the next higher location and displayed to the immediate "right" of the previous entry. A DISPLAY FULL signal is provided after 8 entries; this signal can be used for cascading devices together. A CLR pin is provided to clear the memory and reset the location counter. The **Random Access** mode allows the processor to select the memory address and display digit for each input word.

The character multiplex scan runs whenever data is not being entered. It scans the memory and CHARACTER drivers, and ensures that the decoding from memory to display is done in the proper sequence. Intercharacter blanking is provided to avoid display ghosting.

## Features

- Single supply +3.3V operation
- 16-Segment fonts with decimal point
- Up to 8 character display driver
- Has internal pull-up resistors of 136Ω Typical
- Microprocessor compatible
- Directly drives LED common cathode displays
- Cascadable without additional hardware
- Standby feature turns display off; puts chip in low power mode
- Sequential entry or random entry of data into display
- Character and segment drivers, All MUX scan circuitry, 8x6 static memory and 64-character ASCII font generator included on-chip
- Pb-free (RoHS compliant)

## Ordering Information

PART NUMBER (Note 2)	PART MARKING	TEMP. RANGE (°C)	PACKAGE (Pb-Free)	PKG. DWG. #
ICM7245AIM44Z	ICM7245 AIM44Z	-25°C to +85°C	44 Ld MQFP	Q44.10x10
ICM7245AIM44ZT (Note 1)	ICM7245 AIM44Z	-25°C to +85°C	44 Ld MQFP (Tape and Reel)	Q44.10x10

### NOTES:

1. Please refer to [TB347](#) for details on reel specifications.
2. These Intersil Pb-free plastic packaged products employ special Pb-free material sets, molding compounds/die attach materials, and 100% matte tin plate plus anneal (e3 termination finish, which is RoHS compliant and compatible with both SnPb and Pb-free soldering operations). Intersil Pb-free products are MSL classified at Pb-free peak reflow temperatures that meet or exceed the Pb-free requirements of IPC/JEDEC J STD-020.
3. For Moisture Sensitivity Level (MSL), please see device information page for [ICM7245](#). For more information on MSL, please see tech brief [TB363](#).

# Pin Configuration

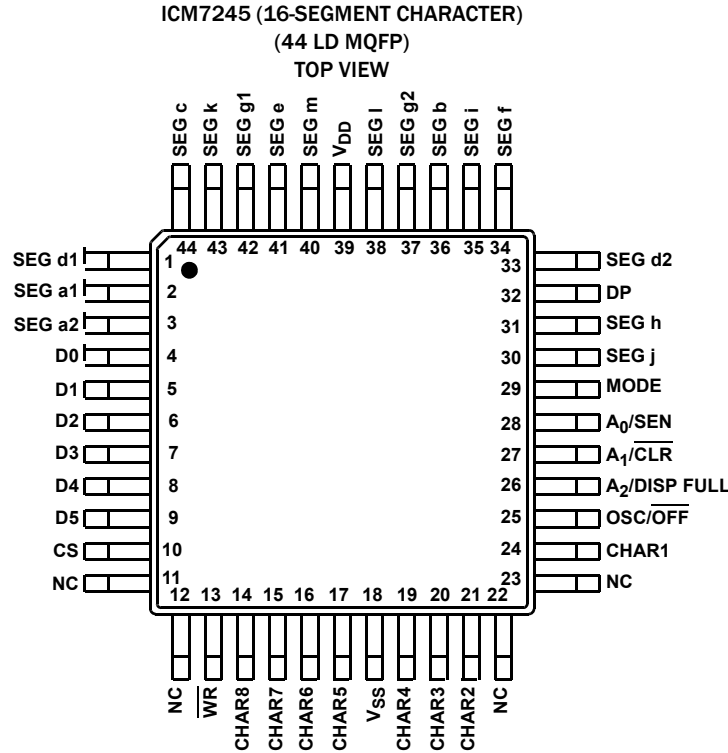

## Pin Descriptions

SIGNAL	PIN	FUNCTION
DO - D5	4 thru 9	6-Bit ASCII Data input pins (active high).
CS	10	Chip Select from $\mu$ P address decoder, etc.
$\overline{WR}$	13	WRite pulse input pin (active low). For an active high write pulse, CS can be used.
MODE	29	Selects data entry MODE. High selects <b>Sequential Access (SA)</b> mode where first entry is displayed in "leftmost" character and subsequent entries appear to the "right". Low selects <b>Random Access (RA)</b> mode where data is displayed on the character addressed via A0 thru A2 Address pins.
A0/SEN	28	In <b>RA</b> mode it is the LSB of the character Address. In <b>SA</b> mode it is used for cascading devices for displays of more than 8 characters (active high enables device controller).
A1/ $\overline{CLR}$	27	In <b>RA</b> mode this is the second bit of the address. In <b>SA</b> mode, a low input will <b>CLEAR</b> the Serial Address Counter, the Data Memory and the display.
A2/DISP FULL	26	In <b>RA</b> mode this is the MSB of the Address. In <b>SA</b> mode, the output goes high after 8 entries, indicating <b>DISPlay FULL</b> .
OSC/ $\overline{OFF}$	25	OSCillator input pin. Adding capacitance to $V_{DD}$ will lower the internal oscillator frequency. An external oscillator can be applied to this pin. A low at this input sets the device into a (shutdown) mode, shutting <b>OFF</b> the display and oscillator but retaining data stored in memory.
SEG d1, SEG a1, SEG a2; SEG j, SEG h, DP, SEG d2, SEG f, SEG i, SEG b, SEG g2, SEG l; SEG m, SEG e, SEG g1, SEG k, SEG c	1 thru 3, 30 thru 38  40 thru 44	SEGment driver outputs.
CHAR8 thru CHAR5, CHAR4 thru CHAR2, CHAR1	14 thru 17, 19 thru 21, 24	CHARacter driver outputs.
$V_{SS}$	18	Supply Ground.
$V_{DD}$	39	Positive Power Supply +3.0V to +3.6V.
NC	11, 12, 22, 23	No connection.

# Functional Block Diagram

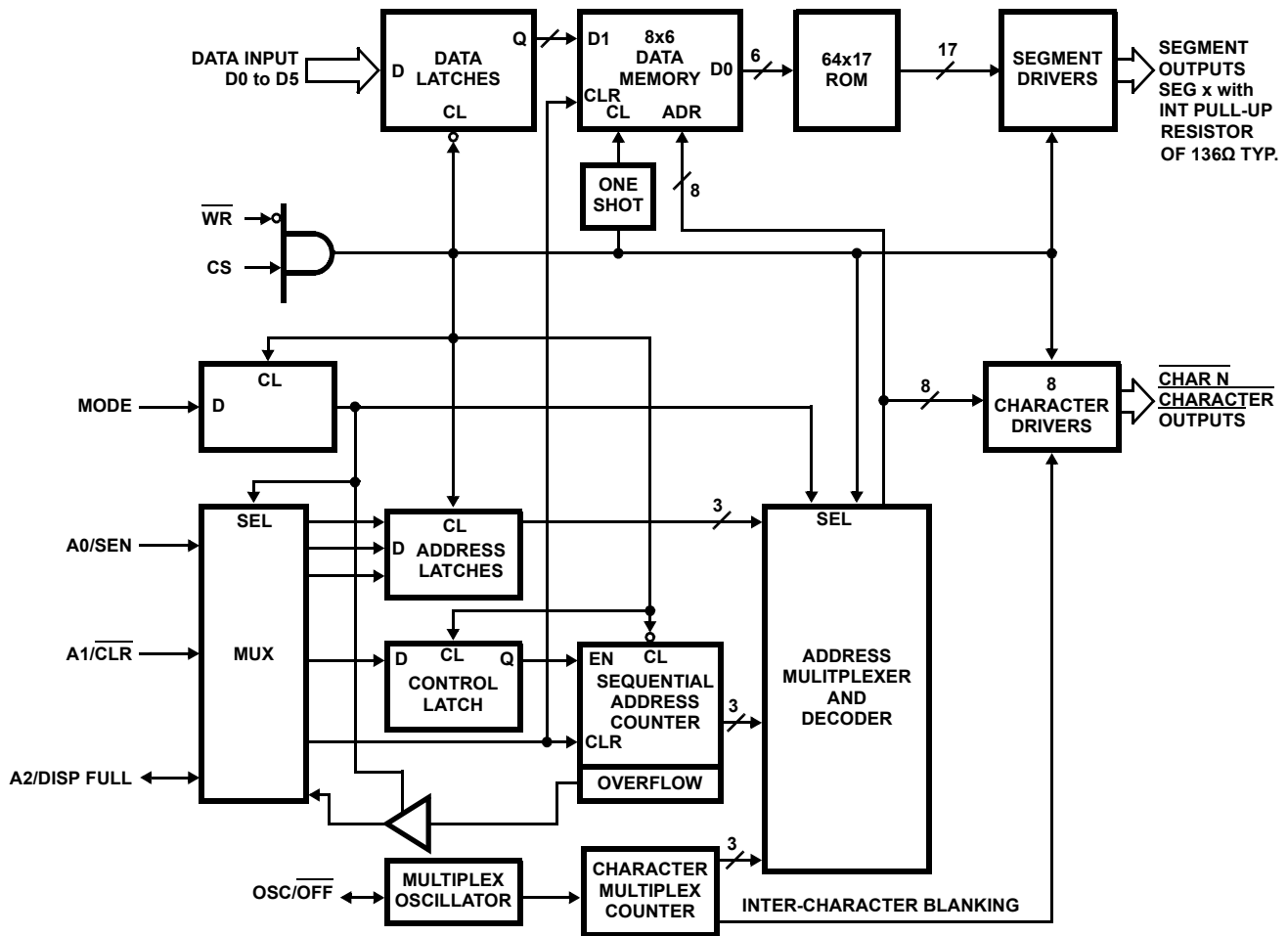

**Absolute Maximum Ratings**

Supply Voltage  $V_{DD} - V_{SS}$  ..... +5.5V  
 Input Voltage (Any Terminal) .....  $V_{DD} + 0.3V$  to  $V_{SS} - 0.3V$   
 CHARACTER Output Current ..... 300mA  
 SEGment Output Current ..... 30mA

**Thermal Information**

Thermal Resistance (Typical)  $\theta_{JA}$  ( $^{\circ}C/W$ )  $\theta_{JC}$  ( $^{\circ}C/W$ )  
 44 Ld MQFP Package (Notes 4, 5) ..... 70 21  
 Storage Temperature Range .....  $-65^{\circ}C$  to  $+150^{\circ}C$   
 Pb-Free Reflow Profile ..... see link below  
<http://www.intersil.com/pbfree/Pb-FreeReflow.asp>

**Operating Conditions**

Temperature Range .....  $-25^{\circ}C$  to  $+85^{\circ}C$

CAUTION: Do not operate at or near the maximum ratings listed for extended periods of time. Exposure to such conditions may adversely impact product reliability and result in failures not covered by warranty.

NOTES:

4.  $\theta_{JA}$  is measured with the component mounted on a low effective thermal conductivity test board in free air. See Tech Brief [TB379](#) for details.
5. For  $\theta_{JC}$ , the “case temp” location is taken at the package top center.

**Electrical Specifications**  $V_{DD} = 3.3V, V_{SS} = 0V, T_A = +25^{\circ}C$ , Unless Otherwise Specified.

PARAMETER	SYMBOL	TEST CONDITIONS	MIN	TYP	MAX	UNITS
<b>DC CHARACTERISTICS</b>						
Supply Voltage ( $V_{DD} - V_{SS}$ )	$V_{SUPP}$		3	3.3	3.6	V
Operating Supply Current	$I_{DD}$	$V_{SUPP} = 3.6V, 10$ Segments ON, All 8 Characters	-	50	-	mA
Quiescent Supply Current	$I_{STBY}$	$V_{SUPP} = 3.6V, OSC/\overline{OFF}$ Pin < 0.5V, CS = $V_{SS}$	-	3.2	25	$\mu A$
Input High Voltage	$V_{IH}$		2.0	-	-	V
Input Low Voltage	$V_{IL}$		-	-	0.8	V
Input Current	$I_{IN}$		-10	-	+10	$\mu A$
CHARacter Drive Current	$I_{CHAR}$	$V_{SUPP} = 3.3V, V_{OUT} = 1V$	70	135	-	mA
		$V_{SUPP} = 3.0V, V_{OUT} = 2V$	120	175	235	mA
CHARacter Leakage Current	$I_{CHLK}$		-	-	100	$\mu A$
SEGment Drive Current	$I_{SEG}$	$V_{SUPP} = 3.3V, V_{OUT} = 2V$	3.7	5.1	6.7	mA
SEGment Leakage Current	$I_{SLK}$		-	0.02	10	$\mu A$
DISPlay FULL Output Low	$V_{OL}$	$I_{OL} = 1.6mA$	-	-	0.4	V
DISPlay FULL Output High	$V_{OH}$	$I_{IH} = 100\mu A$	2.4	-	-	V
Display Scan Rate	$f_{DS}$		-	300	-	Hz

**Electrical Specifications** Drive levels 0.4V and 2.4V, timing measured at 0.8V and 2.0V.  $V_{DD} = 3.3V, T_A = +25^{\circ}C$ , Unless Otherwise Specified.

PARAMETER	SYMBOL	TEST CONDITIONS	MIN	TYP	MAX	UNITS
<b>AC CHARACTERISTICS</b>						
$\overline{WR}, \overline{CLear}$ Pulse Width Low	$t_{WPI}$		500	250	-	ns
$\overline{WR}, \overline{CLear}$ Pulse Width High (Note 6)	$t_{WPH}$		-	250	-	ns
Data Hold Time	$t_{DH}$		0	-100	-	ns
Data Setup Time	$t_{DS}$		250	150	-	ns
Address Hold Time	$t_{AH}$		125	-	-	ns
Address Setup Time	$t_{AS}$		100	-	-	ns
CS Setup Time	$t_{CS}$		0	-	-	ns
Pulse Transition Time	$t_T$		-	-	100	ns
SEN Setup Time	$t_{SEN}$		0	-25	-	ns
Display Full Delay	$t_{WDF}$		760	540	-	ns

## Capacitance

PARAMETER	SYMBOL	TEST CONDITIONS	MIN	TYP	MAX	UNITS
Input Capacitance	$C_{IN}$	(Note 7)	-	5	-	pF
Output Capacitance	$C_O$	(Note 7)	-	5	-	pF

NOTES:

- 6. In Sequential mode  $\overline{WR}$  high must be  $\geq T_{SEN} + T_{WDF}$ .
- 7. For design reference only, not tested.

## Timing Waveforms

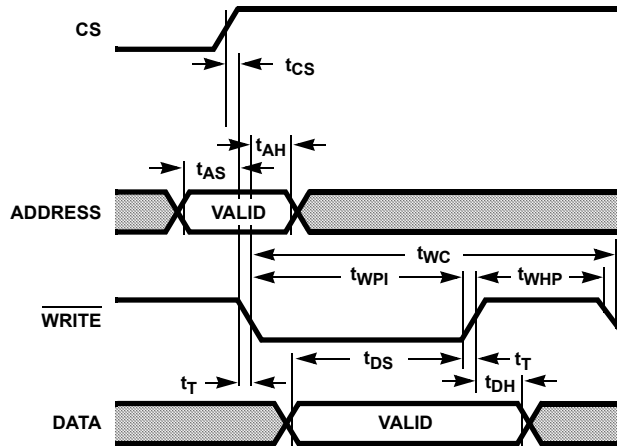

FIGURE 1. RANDOM ACCESS TIMING

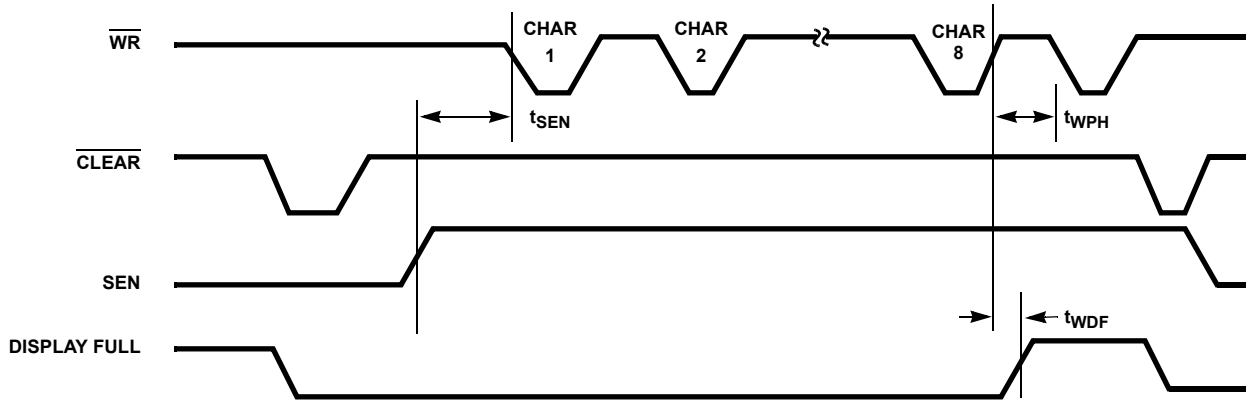

FIGURE 2. SEQUENTIAL ACCESS MODE TIMING (MODE = 1)

# Timing Waveforms (Continued)

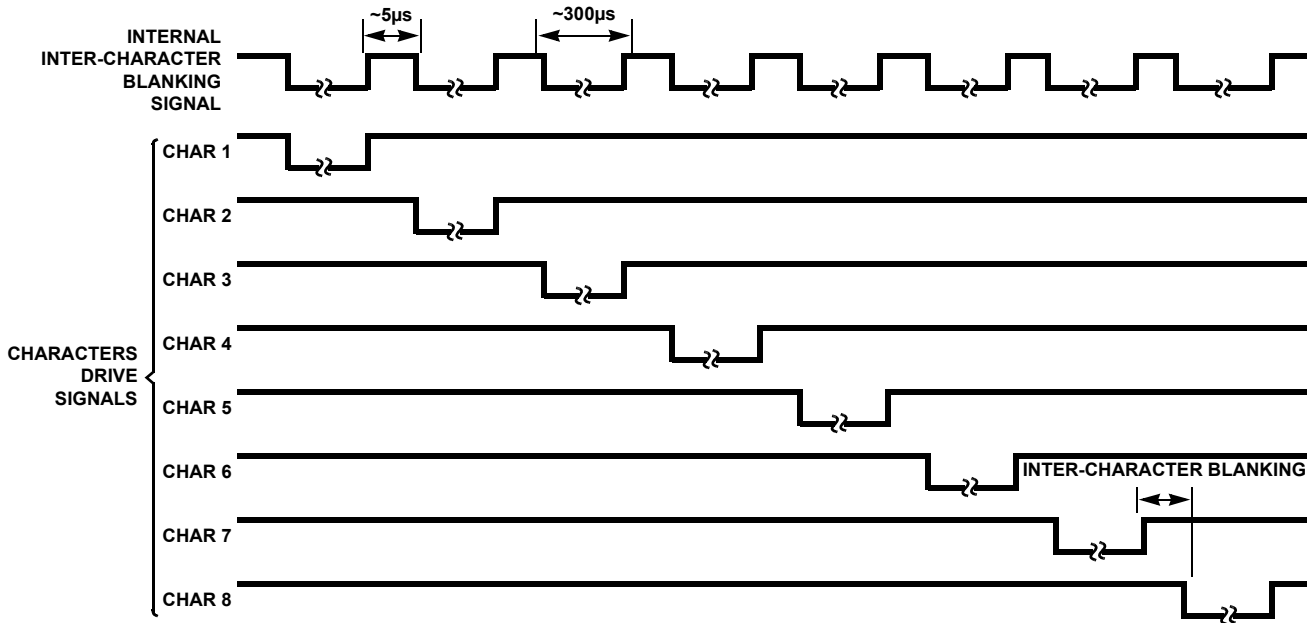

FIGURE 3. DISPLAY CHARACTERS MULTIPLEX TIMING DIAGRAM

# Test Circuit

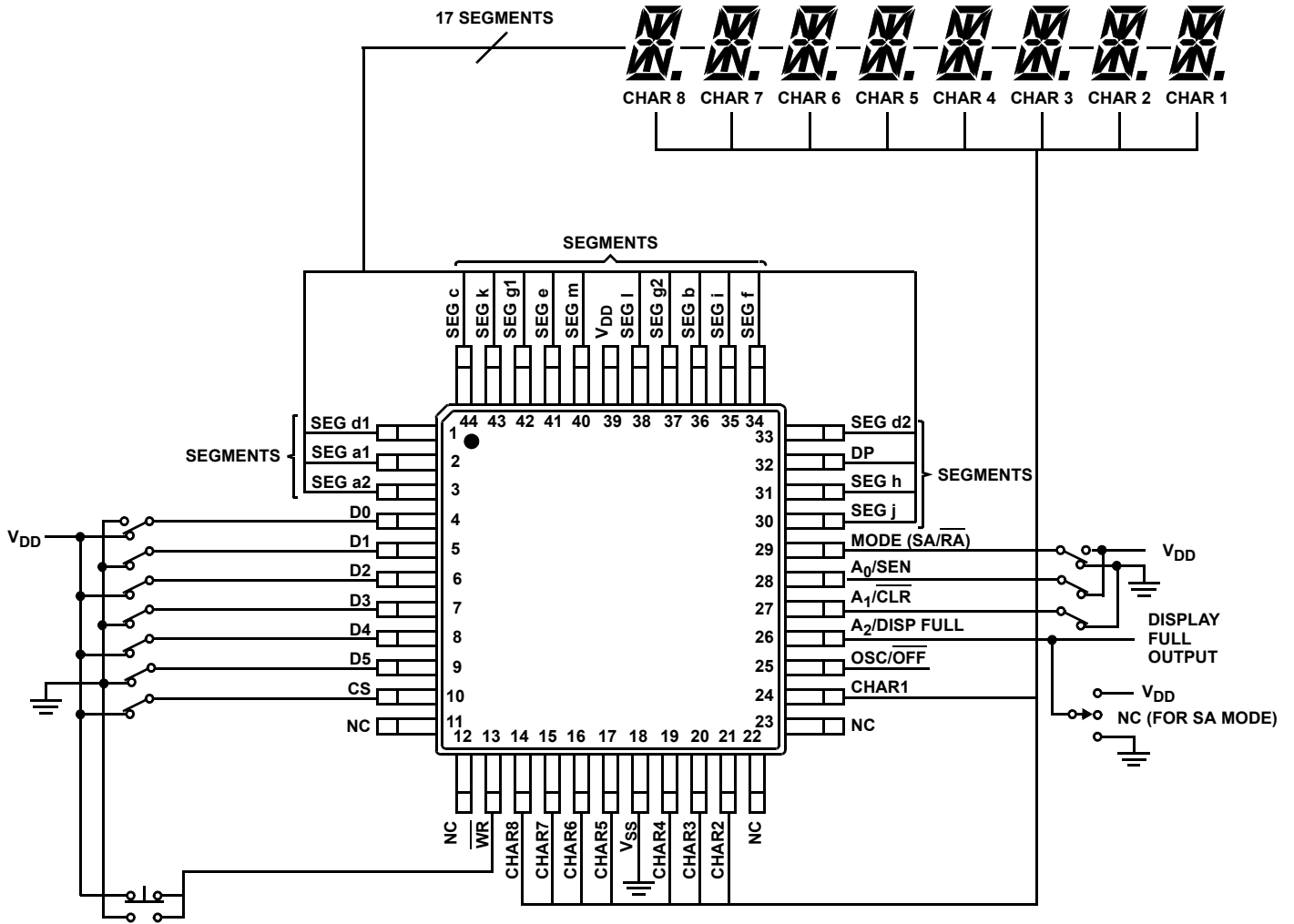

FIGURE 4.

# Typical Applications

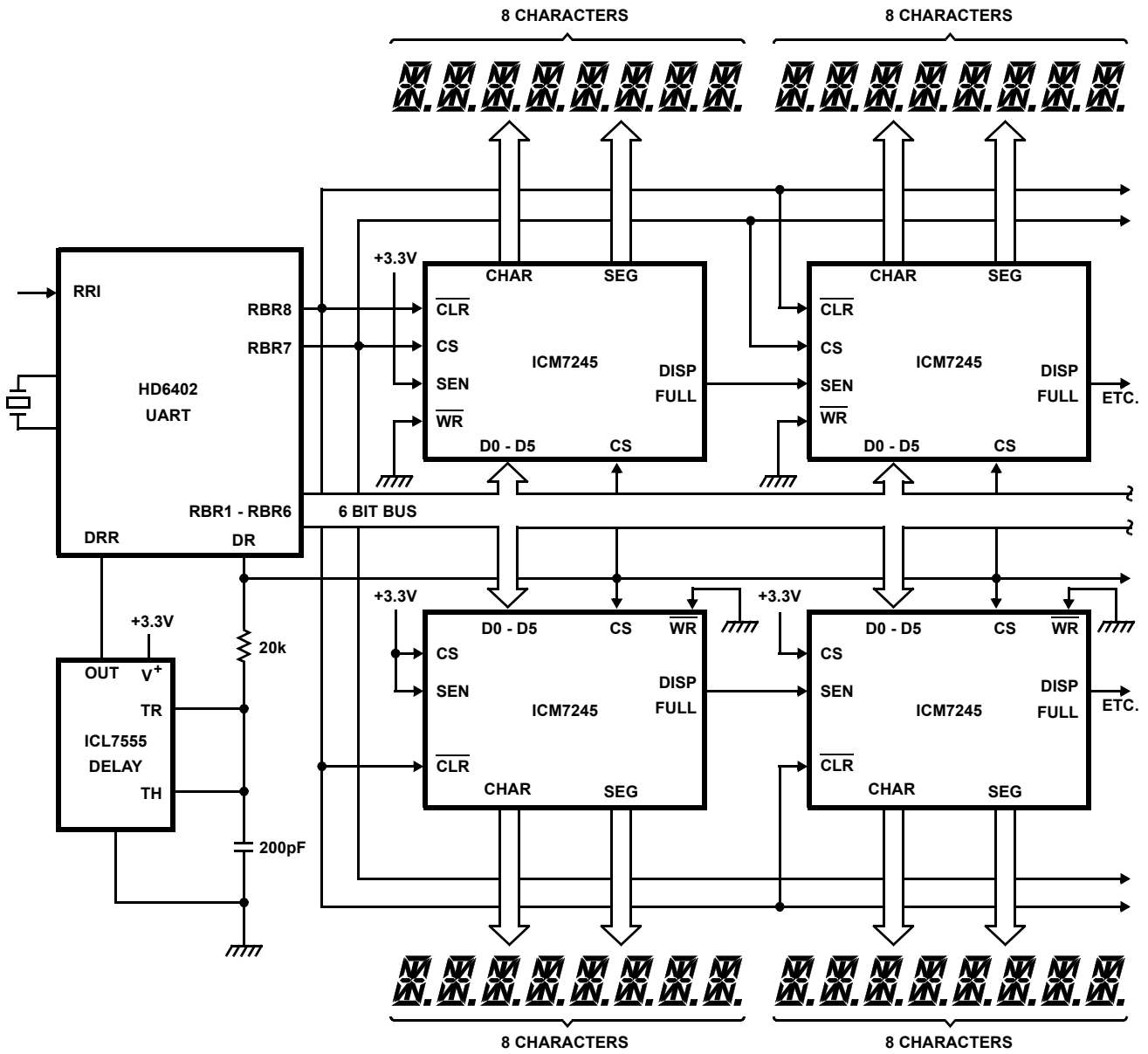

FIGURE 5. DRIVING TWO ROWS OF CHARACTERS FROM A SERIAL INPUT

# Typical Applications (Continued)

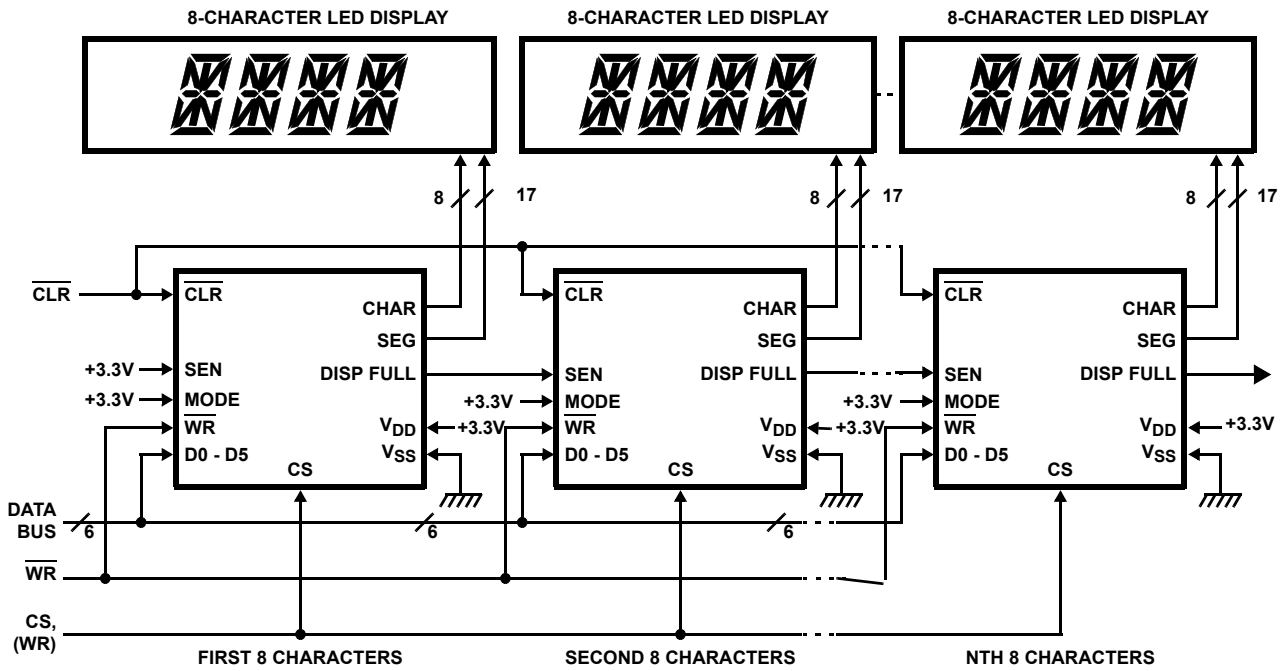

FIGURE 6. MULTICHARACTER DISPLAY USING SEQUENTIAL ACCESS MODE

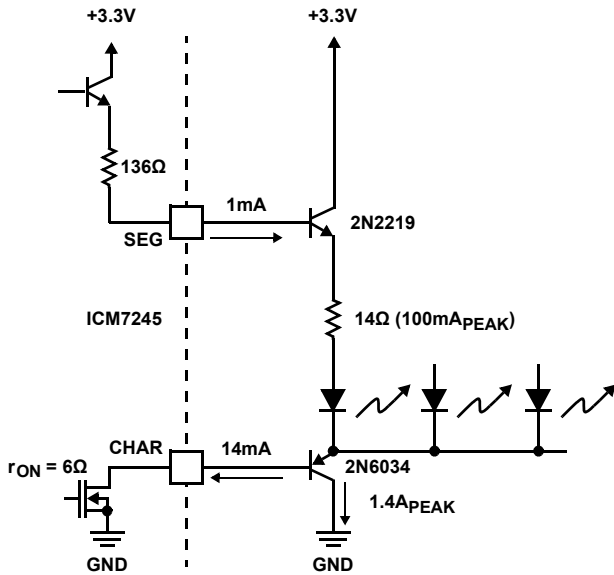

FIGURE 7A. COMMON CATHODE DISPLAY

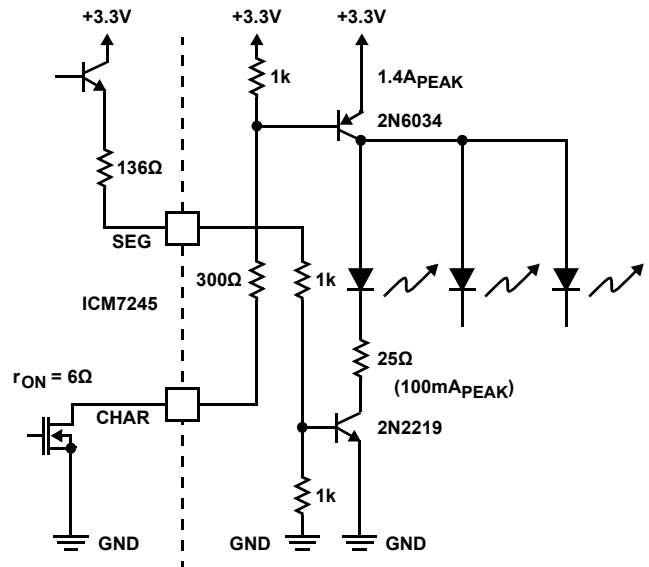

FIGURE 7B. COMMON ANODE DISPLAY

FIGURE 7. DRIVING LARGE DISPLAYS

## Typical Applications (Continued)

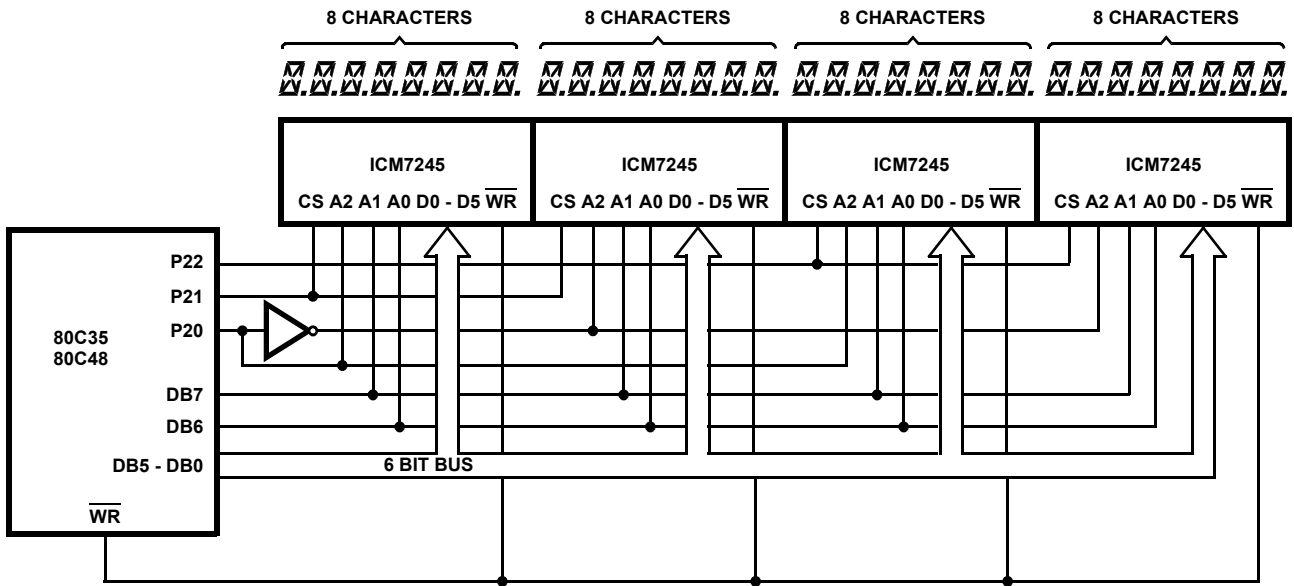
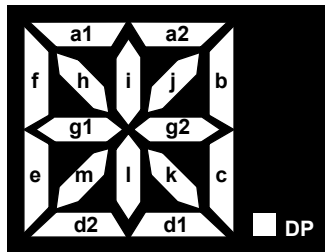

FIGURE 8. RANDOM ACCESS 32-CHARACTER DISPLAY IN A 80C48 SYSTEM

## Display Font and Segment Assignments



D5, D4	0	0	A	B	C	D	E	F	G	H	I	J	K	L	M	N	O
	0	1	P	Q	R	S	T	U	V	W	X	Y	Z	[	]	^	_
	1	0	!	"	#	\$	%	&	'	(	)	*	+	,	-	.	/
	1	1	0	1	2	3	4	5	6	7	8	9	.	/	^	_	7
	D3	0	0	0	0	0	0	0	0	1	1	1	1	1	1	1	1
	D2	0	0	0	0	1	1	1	1	0	0	0	0	1	1	1	1
	D1	0	0	1	1	0	0	1	1	0	0	1	1	0	0	1	1
	D0	0	1	0	1	0	1	0	1	0	1	0	1	0	1	0	1

FIGURE 9. 16-SEGMENT CHARACTER FONT WITH DECIMAL POINT

## Display Font and Segment Assignments (Continued)

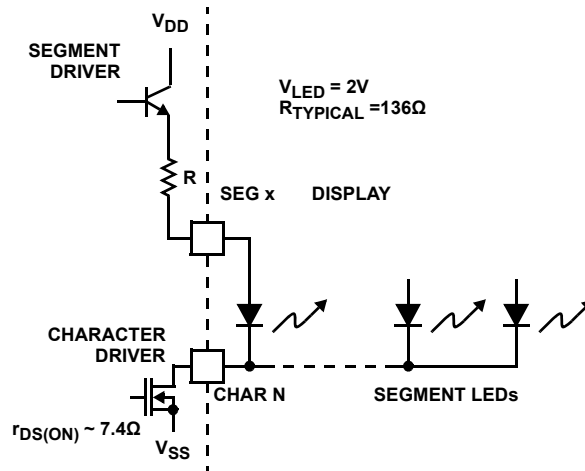

FIGURE 10. SEGMENT AND CHARACTER DRIVERS OUTPUT CIRCUIT

## Detailed Description

### $\overline{WR}$ , CS

These pins are immediately functionally ANDed, so all actions described as occurring on an edge of  $\overline{WR}$ , with CS enabled, will occur on the equivalent (last) enabling or (first) disabling edge of any of these inputs. The delays from CS pins are slightly (about 5ns) greater than from  $\overline{WR}$  due to the additional inverter required on the former.

### MODE

The MODE pin input is latched on the falling edge of  $\overline{WR}$  (or its equivalent, see  $\overline{WR}$  description). The location (in Data Memory) where incoming data will be placed is determined either from the Address pins or the Sequential Address Counter. This is controlled by MODE input. MODE also controls the function of A0/SEN, A1/CLR, and A2/DISPLAY FULL lines.

### Random Access Mode

When the internal mode latch is set for **Random Access (RA)** (MODE latched low), the Address input on A0, A1 and A2 will be latched by the falling edge of  $\overline{WR}$  (or its equivalent). Subsequent changes on the Address lines will not affect device operation. This allows use of a multiplexed 6-bit bus controlling both address and data, with timing controlled by  $\overline{WR}$ .

### Sequential Access Mode

If the internal latch is set for **Sequential Access (SA)**, (MODE latched high), the Serial ENable input or SEN will be latched on the falling edge of  $\overline{WR}$  (or its equivalent). The  $\overline{CLR}$  input is asynchronous, and will force-clear the Sequential Address Counter to address 000 (CHARacter 1), and set all Data Memory contents to 100000 (blank) at any time. The DISPLAY FULL output will be active in SA mode to indicate the overflow status of the Sequential Address Counter. If this output is low, and SEN is (latched) high, the contents of the Counter will be used to establish the Data Memory location for the Data input. The Counter is then incremented on the rising edge of  $\overline{WR}$ . If

SEN is low, or DISPLAY FULL is high, no action will occur. This allows easy “daisy-chaining” of display drivers for multiple character displays in a **Sequential Access** mode.

### Changing Modes

Care must be exercised in any application involving changing from one mode to another. The change will occur only on a falling edge of  $\overline{WR}$  (or its equivalent). When changing mode from **Sequential Access** to **Random Access**, note that A2/DISPLAY FULL will be an output until  $\overline{WR}$  has fallen low, and an Address drive here could cause a conflict. When changing from **Random Access** to **Sequential Access**, A1/CLR should be high to avoid inadvertent clearing of the Data Memory and Sequential Address Counter. DISPLAY FULL will become active immediately after the rising edge of  $\overline{WR}$ .

### Data Entry

The input Data is latched on the rising edge of  $\overline{WR}$  (or its equivalent) and then stored in the Data Memory location determined as described above. The six Data bits can be multiplexed with the Address information on the same lines in **Random Access** mode. Timing is controlled by the  $\overline{WR}$  input.

### OSC/ $\overline{OFF}$

The device includes a relaxation oscillator with an internal capacitor and a nominal frequency of 200kHz. By adding external capacitance to  $V_{DD}$  at the OSC/ $\overline{OFF}$  pin, this frequency can be reduced as far as desired. Alternatively, an external signal can be injected on this pin. The oscillator (or external) frequency is pre-divided by 64, and then further divided by 8 in the Multiplex Counter, to drive the CHARACTER drive lines (Figure 3). An inter-character blanking signal is derived from the pre-divider. An additional comparator on the OSC/ $\overline{OFF}$  input detects a level lower than the relaxation oscillator's range, and blanks the display, disables the DISPLAY FULL output (if active), and clears the pre-divider and Multiplex Counter. This puts the circuit in a low-power-dissipation mode

in which all outputs are effectively open circuits, except for parasitic diodes to the supply lines. Thus a display connected to the output may be driven by another circuit (including another ICM7245) without driver conflicts.

**Display Output**

The output of the Multiplex Counter is decoded and multiplexed into the address input of the Data Memory, except during WR operations (in Sequential Access mode, with SEN high and DISPLAY FULL low), when it scans through the display data. The address decoder also drives the CHARACTER outputs, except during the inter-character blanking interval (nominally about 5µs). Each CHARACTER output lasts nominally about 300µs, and

is repeated nominally every 2.5ms, i.e., at a 400Hz rate (times are based on internal oscillator without external capacitor).

The 6 bits read from the Data Memory are decoded in the ROM to the 17 segment signals, which drive the SEGMENT outputs. Both CHARACTER and SEGMENT outputs are disabled during WR operations (with SEN high and DISPLAY FULL Low for **Sequential Access** mode). The outputs may also be disabled by pulling OSC/OFF low.

The decode pattern from 6 bits to 17 segments is done by a ROM pattern according to the ASCII font shown. Custom decode patterns can be arranged, within these limitations, by contacting [Intersil sales support](#).

**Revision History**

The revision history provided is for informational purposes only and is believed to be accurate, but not warranted. Please go to the web to make sure that you have the latest revision.

DATE	REVISION	CHANGE
October 29, 2013	FN8587.0	Initial Release

**About Intersil**

Intersil Corporation is a leader in the design and manufacture of high-performance analog, mixed-signal and power management semiconductors. The company's products address some of the largest markets within the industrial and infrastructure, personal computing and high-end consumer markets. For more information about Intersil, visit our website at [www.intersil.com](http://www.intersil.com).

For the most updated datasheet, application notes, related documentation and related parts, please see the respective product information page found at [www.intersil.com](http://www.intersil.com). You may report errors or suggestions for improving this datasheet by visiting [www.intersil.com/en/support/ask-an-expert.html](http://www.intersil.com/en/support/ask-an-expert.html). Reliability reports are also available from our website at <http://www.intersil.com/en/support/qualandreliability.html#reliability>

© Copyright Intersil Americas LLC 2013. All Rights Reserved.  
 All trademarks and registered trademarks are the property of their respective owners.

For additional products, see [www.intersil.com/en/products.html](http://www.intersil.com/en/products.html)

Intersil products are manufactured, assembled and tested utilizing ISO9001 quality systems as noted in the quality certifications found at [www.intersil.com/en/support/qualandreliability.html](http://www.intersil.com/en/support/qualandreliability.html)

*Intersil products are sold by description only. Intersil may modify the circuit design and/or specifications of products at any time without notice, provided that such modification does not, in Intersil's sole judgment, affect the form, fit or function of the product. Accordingly, the reader is cautioned to verify that datasheets are current before placing orders. Information furnished by Intersil is believed to be accurate and reliable. However, no responsibility is assumed by Intersil or its subsidiaries for its use; nor for any infringements of patents or other rights of third parties which may result from its use. No license is granted by implication or otherwise under any patent or patent rights of Intersil or its subsidiaries.*

For information regarding Intersil Corporation and its products, see [www.intersil.com](http://www.intersil.com)

**Metric Plastic Quad Flatpack Packages (MQFP)**

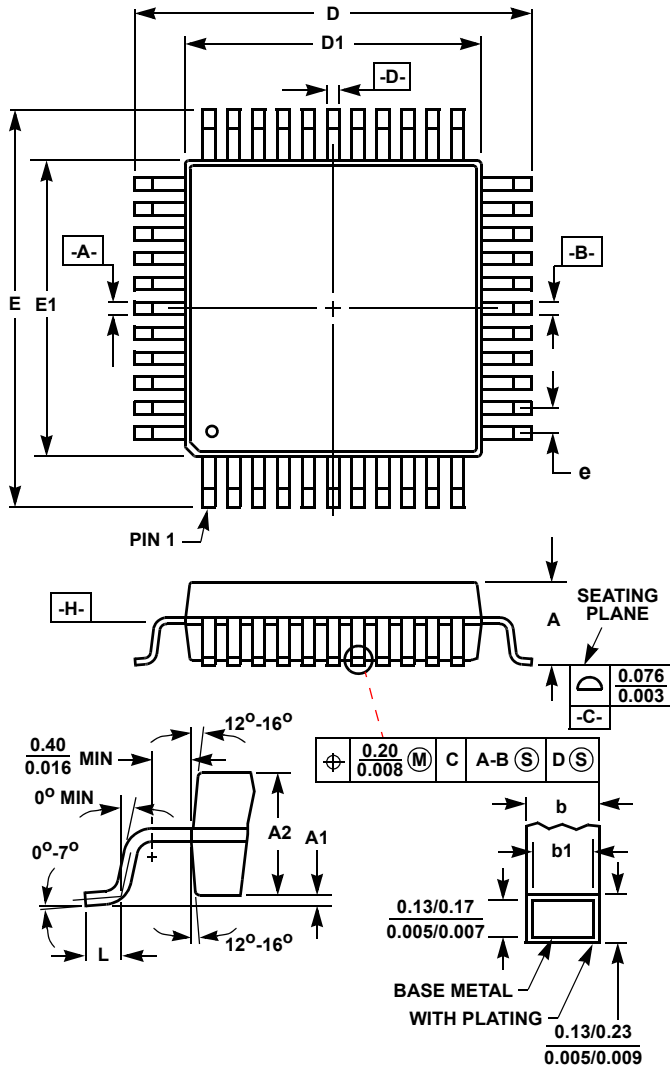

**Q44.10x10 (JEDEC MS-022AB ISSUE B)  
44 LEAD METRIC PLASTIC QUAD FLATPACK PACKAGE**

SYMBOL	INCHES		MILLIMETERS		NOTES
	MIN	MAX	MIN	MAX	
A	-	0.096	-	2.45	-
A1	0.004	0.010	0.10	0.25	-
A2	0.077	0.083	1.95	2.10	-
b	0.012	0.018	0.30	0.45	6
b1	0.012	0.016	0.30	0.40	-
D	0.515	0.524	13.08	13.32	3
D1	0.389	0.399	9.88	10.12	4, 5
E	0.516	0.523	13.10	13.30	3
E1	0.390	0.398	9.90	10.10	4, 5
L	0.029	0.040	0.73	1.03	-
N	44		44		7
e	0.032 BSC		0.80 BSC		-



Rev. 2 4/99

**NOTES:**

1. Controlling dimension: MILLIMETER. Converted inch dimensions are not necessarily exact.
2. All dimensions and tolerances per ANSI Y14.5M-1982.
3. Dimensions D and E to be determined at seating plane **-C-**.
4. Dimensions D1 and E1 to be determined at datum plane **-H-**.
5. Dimensions D1 and E1 do not include mold protrusion. Allowable protrusion is 0.25mm (0.010 inch) per side.
6. Dimension b does not include dambar protrusion. Allowable dambar protrusion shall be 0.08mm (0.003 inch) total.
7. "N" is the number of terminal positions.

## Looking for pricing, stock, or lifecycle information?

Click below to explore more details on WIN SOURCE:

-  [View ICM7245BIM44ZT on WIN SOURCE](#)
-  [Renesas Electronics America](#) Information

## Optimize Your Supply Chain with WIN SOURCE Solutions

-  Global Sourcing Solution
-  Obsolete Management
-  Cost Control Management
-  Shortage Management
-  Alternative Solution
-  Excess Inventory Management