



**THE DATASHEET OF
EV_ICM-20648**



6-Axis MEMS MotionTracking™ Device with Enhanced EIS Support

GENERAL DESCRIPTION

The ICM-20648 is a 6-axis MotionTracking device that is ideally suited for Smartphones, Tablets, Wearable Sensors, and IoT applications.

- 3-axis gyroscope, 3-axis accelerometer, 3-axis compass, and a Digital Motion Processor™ (DMP™) in a 3x3x0.9mm (24-pin QFN) package
- DMP offloads computation of motion processing algorithms from the host processor, improving system power performance
- Software drivers are fully compliant with Google's latest Android release
- Enhanced FSYNC functionality to improve timing for applications like EIS

ICM-20648 supports an auxiliary I²C interface to external sensors, on-chip 16-bit ADCs, programmable digital filters, an embedded temperature sensor, and programmable interrupts. The device features an operating voltage range down to 1.71V. Communication ports include I²C and high speed SPI at 7MHz.

ORDERING INFORMATION

PART	TEMP RANGE	PACKAGE
ICM-20648†	-40°C to +85°C	24-Pin QFN

†Denotes RoHS and Green-Compliant Package

BLOCK DIAGRAM



APPLICATIONS

- Smartphones and Tablets
- Wearable Sensors
- IoT Applications
- Motion-based game controllers
- 3D remote controls for Internet connected DTVs and set top boxes, 3D mice

FEATURES

- 3-Axis Gyroscope with Programmable FSR of ±250dps, ±500dps, ±1000dps and ±2000dps
- 3-Axis Accelerometer with Programmable FSR of ±2g, ±4g, ±8g and ±16g
- Onboard Digital Motion Processor (DMP)
- Android support
- Auxiliary I²C interface for external sensors
- On-Chip 16-bit ADCs and Programmable Filters
- 7MHz SPI or 400kHz Fast Mode I²C
- Digital-output temperature sensor
- VDD operating range of 1.71 to 3.6V
- MEMS structure hermetically sealed and bonded at wafer level
- RoHS and Green compliant

TYPICAL OPERATING CIRCUIT

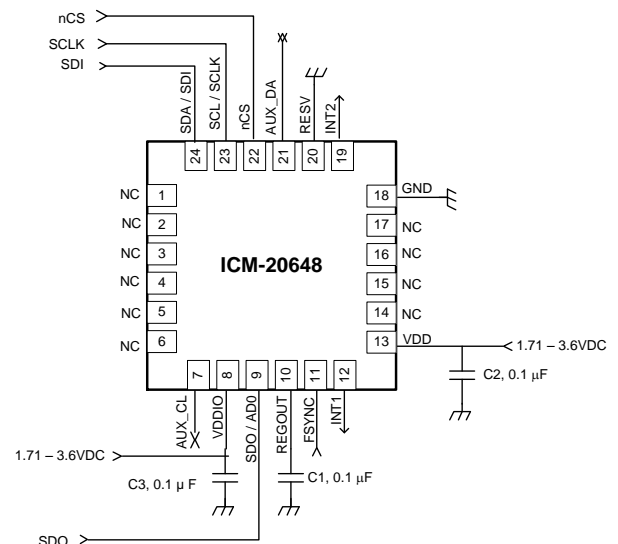

Looking for pricing, stock, or lifecycle information?

Click below to explore more details on WIN SOURCE:

 [View EV_ICM-20648](#) on WIN SOURCE

 [TDK InvenSense](#) Information

Optimize Your Supply Chain with WIN SOURCE Solutions

-  Global Sourcing Solution
-  Obsolete Management
-  Cost Control Management
-  Shortage Management
-  Alternative Solution
-  Excess Inventory Management