



**THE DATASHEET OF
ICE5LP4K-CM36ITR50**





iCE40 Ultra™ Family Data Sheet

DS1048 Version 2.0, June 2016

General Description

iCE40 Ultra family is an ultra-low power FPGA and sensor manager designed for ultra-low power mobile applications, such as smartphones, tablets and hand-held devices. The iCE40 Ultra family includes integrated SPI and I²C blocks to interface with virtually all mobile sensors and application processors. The iCE40 Ultra family also features two on-chip oscillators, 10 kHz and 48 MHz. The LFOSC (10 kHz) is ideal for low power function in always-on applications, while HFOSC (48 MHz) can be used for awaken activities.

The iCE40 Ultra family also features DSP functional block to off-load Application Processor to pre-process information sent from the mobile sensors. The embedded RGB PWM IP, with the three 24 mA constant current RGB outputs on the iCE40 Ultra provides all the necessary logic to directly drive the service LED, without the need of external MOSFET or buffer.

The 500 mA constant current IR driver output provides a direct interface to external LED for application such as IrDA functions. Users simply implement the modulation logic that meets his needs, and connect the IR driver directly to the LED, without the need of external MOSFET or buffer. This high current IR driver can also be used as Barcode Emulation, sending barcode information to external Barcode Reader.

The iCE40 Ultra family of devices are targeting for mobile applications to perform functions such as IrDA, Service LED, Barcode Emulation, GPIO Expander, SDIO Level Shift, and other custom functions.

The iCE40 Ultra family features three device densities, from 1100 to 3520 Look Up Tables (LUTs) of logic with programmable I/Os that can be used as either SPI/I²C interface ports or general purpose I/O's. It also has up to 80 kbits of Block RAMs to work with user logic.

Features

- **Flexible Logic Architecture**
 - Three devices with 1100 to 3520 LUTs
 - Offered in WLCS, ucfBGA and QFN packages
- **Ultra-low Power Devices**
 - Advanced 40 nm ultra-low power process
 - As low as 71 μ A standby current typical
- **Embedded Memory**
 - Up to 80 kbits sysMEM™ Embedded Block RAM
- **Two Hardened I²C Interfaces**
- **Two Hardened SPI Interfaces**
- **Two On-Chip Oscillators**
 - Low Frequency Oscillator – 10 kHz
 - High Frequency Oscillator – 48 MHz
- **24 mA Current Drive RGB LED Outputs**
 - Three drive outputs in each device
 - User selectable sink current up to 24 mA
- **500 mA Current Drive IR LED Output**
 - One IR drive output in each device
 - User selectable sink current up to 500 mA
- **On-chip DSP**
 - Signed and unsigned 8-bit or 16-bit functions
 - Functions include Multiplier, Accumulator, and Multiply-Accumulate (MAC)
- **Flexible On-Chip Clocking**
 - Eight low skew global signal resource, six can be directly driven from external pins
 - One PLL with dynamic interface per device
- **Flexible Device Configuration**
 - SRAM is configured through:
 - Standard SPI Interface
 - Internal Nonvolatile Configuration Memory (NVCM)
- **Ultra-Small Form Factor**
 - As small as 2.078 mm x 2.078 mm
- **Applications**
 - Smartphones
 - Tablets and Consumer Handheld Devices
 - Handheld Commercial and Industrial Devices
 - Multi Sensor Management Applications
 - Sensor Pre-processing and Sensor Fusion
 - Always-On Sensor Applications
 - USB 3.1 Type C Cable Detect / Power Delivery Applications

Table 1-1. iCE40 Ultra Family Selection Guide

Part Number	iCE5LP1K	iCE5LP2K	iCE5LP4K
Logic Cells (LUT + Flip-Flop)	1100	2048	3520
EBR Memory Blocks	16	20	20
EBR Memory Bits	64 k	80 k	80 k
PLL Block	1	1	1
NVCM	Yes	Yes	Yes
DSP Blocks (MULT16 with 32-bit Accumulator)	2	4	4
Hardened I2C, SPI	1,1	2,2	2,2
HF Oscillator (48 MHz)	1	1	1
LF Oscillator (10 kHz)	1	1	1
24 mA LED Sink	3	3	3
500 mA LED Sink	1	1	1
Embedded PWM IP	Yes	Yes	No
Packages, ball pitch, dimension	Total User I/O Count		
36-ball WLCSP, 0.35 mm, 2.078 mm x 2.078 mm	26	26	26
36-ball ucfBGA, 0.40 mm, 2.5 mm x 2.5 mm	26	26	26
48-ball QFN Package, 0.5 mm, 7.0 mm x 7.0 mm	39	39	39

Introduction

The iCE40 Ultra family of ultra-low power FPGAs has three devices with densities ranging from 1100 to 3520 Look-Up Tables (LUTs) fabricated in a 40 nm Low Power CMOS process. In addition to LUT-based, low-cost programmable logic, these devices also feature Embedded Block RAM (EBR), on-chip Oscillators (LFOSC, HFOSC), two hardened I²C Controllers, two hardened SPI Controllers, three 24 mA RGB LED open-drain drivers, a 500 mA IR LED open-drain drivers, and DSP blocks. These features allow the devices to be used in low-cost, high-volume consumer and mobile applications.

The iCE40 Ultra FPGAs are available in very small form factor packages, as small as 2.078 mm x 2.078 mm. The small form factor allows the device to easily fit into a lot of mobile applications, where space can be limited. Table 1-1 shows the LUT densities, package and I/O pin count.

The iCE40 Ultra devices offer I/O features such as pull-up resistors. Pull-up features are controllable on a “per-pin” basis.

The iCE40 Ultra devices also provide flexible, reliable and secure configuration from on-chip NVCM. These devices can also configure themselves from external SPI Flash, or be configured by an external master such as a CPU.

Lattice provides a variety of design tools that allow complex designs to be efficiently implemented using the iCE40 Ultra family of devices. Popular logic synthesis tools provide synthesis library support for iCE40 Ultra. Lattice design tools use the synthesis tool output along with the user-specified preferences and constraints to place and route the design in the iCE40 Ultra device. These tools extract the timing from the routing and back-annotate it into the design for timing verification.

Lattice provides in the iCE40 Ultra 1K and 2K device the embedded RGB PWM IP at no extra cost of LUT available to the user, to perform controlling the RGB LED function. This embedded IP allow users to control color, LED ON/OFF time, and breathe rate of the LED. For more information, please refer to Usage Guide in Lattice Design Software.

Lattice provides many pre-engineered IP (Intellectual Property) modules, including a number of reference designs, licensed free of charge, optimized for the iCE40 Ultra FPGA family. Lattice also can provide fully verified bitstream for some of the widely used target functions in mobile device applications, such as ultra-low power sensor management, gesture recognition, IR remote, barcode emulator functions. Users can use these functions as offered by Lattice, or they can use the design to create their own unique required functions. For more information regarding Lattice’s reference designs or fully-verified bitstreams, please contact your local Lattice representative.

Architecture Overview

The iCE40 Ultra family architecture contains an array of Programmable Logic Blocks (PLB), two Oscillator Generators, two user configurable I²C controllers, two user configurable SPI controllers, and blocks of sysMEM™ Embedded Block RAM (EBR) surrounded by Programmable I/O (PIO). Figure 2-1 shows the block diagram of the iCE5LP-4K device.

Figure 2-1. iCE5LP-4K Device, Top View

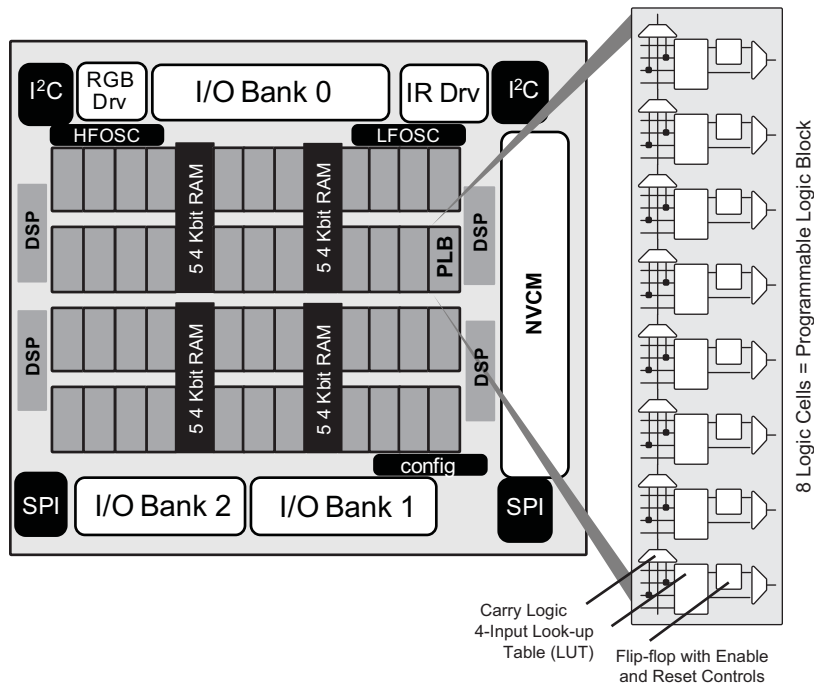

The Programmable Logic Blocks (PLB) and sysMEM EBR blocks, are arranged in a two-dimensional grid with rows and columns. Each column has either PLB or EBR blocks. The PIO cells are located at the top and bottom of the device, arranged in banks. The PLB contains the building blocks for logic, arithmetic, and register functions. The PIOs utilize a flexible I/O buffer referred to as a sysIO buffer that supports operation with a variety of interface standards. The blocks are connected with many vertical and horizontal routing channel resources. The place and route software tool automatically allocates these routing resources.

In the iCE40 Ultra family, there are three sysIO banks, one on top and two at the bottom. User can connect some V_{CCIO}s together, if all the I/Os are using the same voltage standard. Refer to the details in later sections of this document on Power Up Sequence. The sysMEM EBRs are large 4 kbit, dedicated fast memory blocks. These blocks can be configured as RAM, ROM or FIFO with user logic using PLBs.

Every device in the family has two user SPI ports, one of these (right side) SPI port also supports programming and configuration of the device. The iCE40 Ultra also includes two user I²C ports, two Oscillators, and high current RGB and IR LED sinks.

PLB Blocks

The core of the iCE40 Ultra device consists of Programmable Logic Blocks (PLB) which can be programmed to perform logic and arithmetic functions. Each PLB consists of eight interconnected Logic Cells (LC) as shown in Figure 2-2. Each LC contains one LUT and one register.

Figure 2-2. PLB Block Diagram

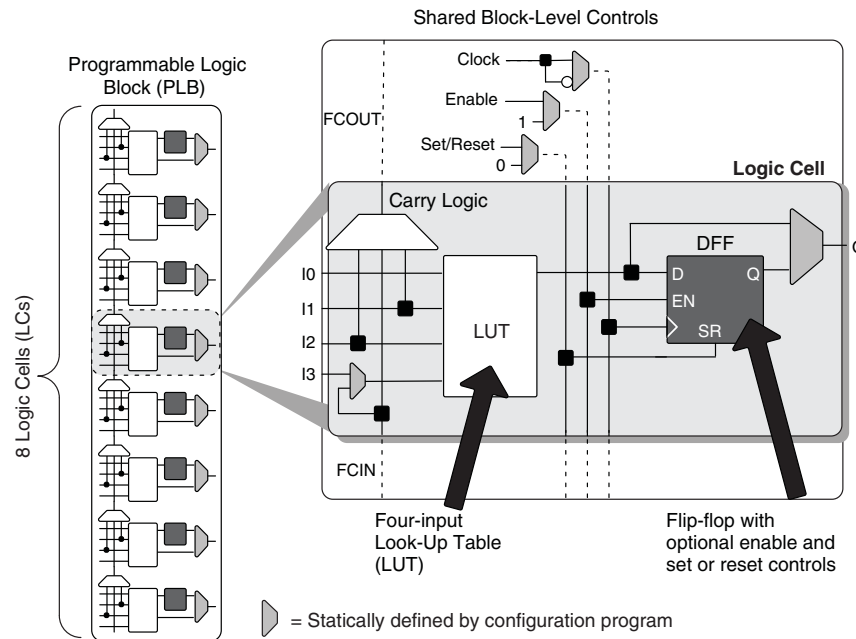

Logic Cells

Each Logic Cell includes three primary logic elements shown in Figure 2-2.

- A four-input Look-Up Table (LUT) builds any combinational logic function, of any complexity, requiring up to four inputs. Similarly, the LUT element behaves as a 16x1 Read-Only Memory (ROM). Combine and cascade multiple LUTs to create wider logic functions.
- A 'D'-style Flip-Flop (DFF), with an optional clock-enable and reset control input, builds sequential logic functions. Each DFF also connects to a global reset signal that is automatically asserted immediately following device configuration.
- Carry Logic boosts the logic efficiency and performance of arithmetic functions, including adders, subtracters, comparators, binary counters and some wide, cascaded logic functions.

Table 2-1. Logic Cell Signal Descriptions

Function	Type	Signal Names	Description
Input	Data signal	I0, I1, I2, I3	Inputs to LUT
Input	Control signal	Enable	Clock enable shared by all LCs in the PLB
Input	Control signal	Set/Reset ¹	Asynchronous or synchronous local set/reset shared by all LCs in the PLB.
Input	Control signal	Clock	Clock one of the eight Global Buffers, or from the general-purpose interconnects fabric shared by all LCs in the PLB
Input	Inter-PLB signal	FCIN	Fast carry in
Output	Data signals	O	LUT or registered output
Output	Inter-PFU signal	FCOUT	Fast carry out

1. If Set/Reset is not used, then the flip-flop is never set/reset, except when cleared immediately after configuration.

Routing

There are many resources provided in the iCE40 Ultra devices to route signals individually with related control signals. The routing resources consist of switching circuitry, buffers and metal interconnect (routing) segments.

The inter-PLB connections are made with three different types of routing resources: Adjacent (spans two PLBs), x4 (spans five PLBs) and x12 (spans thirteen PLBs). The Adjacent, x4 and x12 connections provide fast and efficient connections in the diagonal, horizontal and vertical directions.

The design tool takes the output of the synthesis tool and places and routes the design.

Clock/Control Distribution Network

Each iCE40 Ultra device has six global inputs, two pins on the top bank and four pins on the bottom bank

These global inputs can be used as high fanout nets, clock, reset or enable signals. The dedicated global pins are identified as Gxx and each drives one of the eight global buffers. The global buffers are identified as GBUF[7:0]. These six inputs may be used as general purpose I/O if they are not used to drive the clock nets.

Table 2-2 lists the connections between a specific global buffer and the inputs on a PLB. All global buffers optionally connect to the PLB CLK input. Any four of the eight global buffers can drive logic inputs to a PLB. Even-numbered global buffers optionally drive the Set/Reset input to a PLB. Similarly, odd-numbered buffers optionally drive the PLB clock-enable input. GBUF[7:6, 3:0] can connect directly to G[7:6, 3:0] pins respectively. GBUF4 and GBUF5 can connect to the two on-chip Oscillator Generators (GBUF4 connects to LFOSC, GBUF5 connects to HFOSC).

Table 2-2. Global Buffer (GBUF) Connections to Programmable Logic Blocks

Global Buffer	LUT Inputs	Clock	Clock Enable	Reset
GBUF0	Yes, any 4 of 8 GBUF Inputs	✓	✓	
GBUF1		✓		✓
GBUF2		✓	✓	
GBUF3		✓		✓
GBUF4		✓	✓	
GBUF5		✓		✓
GBUF6		✓	✓	
GBUF7		✓		✓

The maximum frequency for the global buffers are shown in the iCE40 Ultra External Switching Characteristics tables later in this document.

Global Hi-Z Control

The global high-impedance control signal, GHIZ, connects to all I/O pins on the iCE40 Ultra device. This GHIZ signal is automatically asserted throughout the configuration process, forcing all user I/O pins into their high-impedance state.

Global Reset Control

The global reset control signal connects to all PLB and PIO flip-flops on the iCE40 Ultra device. The global reset signal is automatically asserted throughout the configuration process, forcing all flip-flops to their defined wake-up state. For PLB flip-flops, the wake-up state is always reset, regardless of the PLB flip-flop primitive used in the application.

sysCLOCK Phase Locked Loops (PLLs)

The sysCLOCK PLLs provide the ability to synthesize clock frequencies. The iCE40 Ultra devices have one sysCLOCK PLL. REFERENCECLK is the reference frequency input to the PLL and its source can come from an external I/O pin, the internal Oscillator Generators from internal routing. EXTFEEDBACK is the feedback signal to the PLL which can come from internal routing or an external I/O pin. The feedback divider is used to multiply the reference frequency and thus synthesize a higher frequency clock output.

The PLLOUT output has an output divider, thus allowing the PLL to generate different frequencies for each output. The output divider can have a value from 1 to 64 (in increments of 2X). The PLLOUT outputs can all be used to drive the iCE40 Ultra global clock network directly or general purpose routing resources can be used.

The LOCK signal is asserted when the PLL determines it has achieved lock and de-asserted if a loss of lock is detected. A block diagram of the PLL is shown in Figure 2-3.

The timing of the device registers can be optimized by programming a phase shift into the PLLOUT output clock which will advance or delay the output clock with reference to the REFERENCECLK clock. This phase shift can be either programmed during configuration or can be adjusted dynamically. In dynamic mode, the PLL may lose lock after a phase adjustment on the output used as the feedback source and not relock until the tLOCK parameter has been satisfied.

There is an additional feature in the iCE40 Ultra PLL. There are 2 FPGA controlled inputs, SCLK and SDI, that allows the user logic to serially shift in data thru SDI, clocked by SCLK clock. The data shifted in would change the configuration settings of the PLL. This feature allows the PLL to be time multiplexed for different functions, with different clock rates. After the data is shifted in, user would simply pulse the RESET input of the PLL block, and the PLL will re-lock with the new settings. For more details, please refer to TN1251, [iCE40 sysCLOCK PLL Design and Usage Guide](#).

Figure 2-3. PLL Diagram

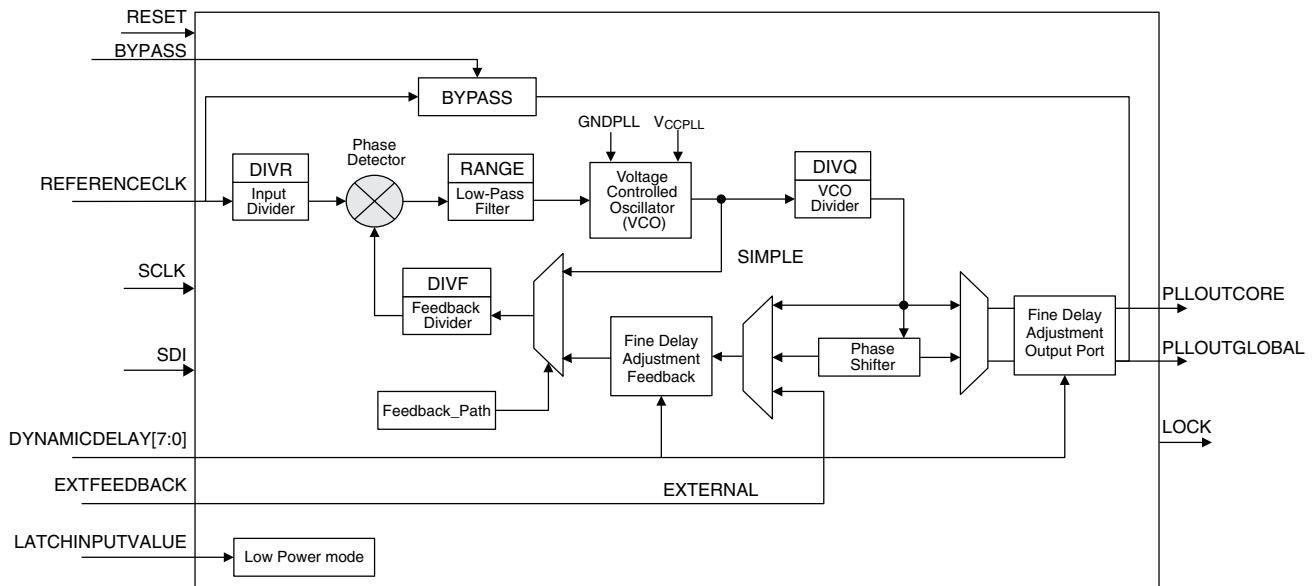

Table 2-3 provides signal descriptions of the PLL block.

Table 2-3. PLL Signal Descriptions

Signal Name	Direction	Description
REFERENCECLK	Input	Input reference clock
BYPASS	Input	The BYPASS control selects which clock signal connects to the PLL-OUT output. 0 = PLL generated signal 1 = REFERENCECLK
EXTFEEDBACK	Input	External feedback input to PLL. Enabled when the FEEDBACK_PATH attribute is set to EXTERNAL.
DYNAMICDELAY[7:0]	Input	Fine delay adjustment control inputs. Enabled when DELAY_ADJUSTMENT_MODE is set to DYNAMIC.
LATCHINPUTVALUE	Input	When enabled, puts the PLL into low-power mode; PLL output is held static at the last input clock value. Set ENABLE ICEGATE_PORTA and PORTB to '1' to enable.
PLLOUTGLOBAL	Output	Output from the Phase-Locked Loop (PLL). Drives a global clock network on the FPGA. The port has optimal connections to global clock buffers GBUF4 and GBUF5.
PLLOUTCORE	Output	Output clock generated by the PLL, drives regular FPGA routing. The frequency generated on this output is the same as the frequency of the clock signal generated on the PLLOUTGLOBAL port.
LOCK	Output	When High, indicates that the PLL output is phase aligned or locked to the input reference clock.
RESET	Input	Active low reset.
SCLK	Input	Input, Serial Clock used for re-programming PLL settings.
SDI	Input	Input, Serial Data used for re-programming PLL settings.

sysMEM Embedded Block RAM Memory

Larger iCE40 Ultra device includes multiple high-speed synchronous sysMEM Embedded Block RAMs (EBRs), each 4 kbit in size. This memory can be used for a wide variety of purposes including data buffering, and FIFO.

sysMEM Memory Block

The sysMEM block can implement single port, pseudo dual port, or FIFO memories with programmable logic resources. Each block can be used in a variety of depths and widths as shown in Table 2-4.

Table 2-4. sysMEM Block Configurations¹

Block RAM Configuration	Block RAM Configuration and Size	WADDR Port Size (Bits)	WDATA Port Size (Bits)	RADDR Port Size (Bits)	RDATA Port Size (Bits)	MASK Port Size (Bits)
SB_RAM256x16 SB_RAM256x16NR SB_RAM256x16NW SB_RAM256x16NRNW	256x16 (4 k)	8 [7:0]	16 [15:0]	8 [7:0]	16 [15:0]	16 [15:0]
SB_RAM512x8 SB_RAM512x8NR SB_RAM512x8NW SB_RAM512x8NRNW	512x8 (4 k)	9 [8:0]	8 [7:0]	9 [8:0]	8 [7:0]	No Mask Port
SB_RAM1024x4 SB_RAM1024x4NR SB_RAM1024x4NW SB_RAM1024x4NRNW	1024x4 (4 k)	10 [9:0]	4 [3:0]	10 [9:0]	4 [3:0]	No Mask Port
SB_RAM2048x2 SB_RAM2048x2NR SB_RAM2048x2NW SB_RAM2048x2NRNW	2048x2 (4 k)	11 [10:0]	2 [1:0]	11 [10:0]	2 [1:0]	No Mask Port

1. For iCE40 Ultra, the primitive name without "Nxx" uses rising-edge Read and Write clocks. "NR" uses rising-edge Write clock, falling-edge Read clock. "NW" uses falling-edge Write clock and rising-edge Read clock. "NRNW" uses falling-edge clocks on both Read and Write.

RAM Initialization and ROM Operation

If desired, the contents of the RAM can be pre-loaded during device configuration.

By preloading the RAM block during the chip configuration cycle and disabling the write controls, the sysMEM block can also be utilized as a ROM.

Memory Cascading

Larger and deeper blocks of RAM can be created using multiple EBR sysMEM Blocks.

RAM4k Block

Figure 2-4 shows the 256x16 memory configurations and their input/output names. In all the sysMEM RAM modes, the input data and addresses for the ports are registered at the input of the memory array.

Figure 2-4. sysMEM Memory Primitives

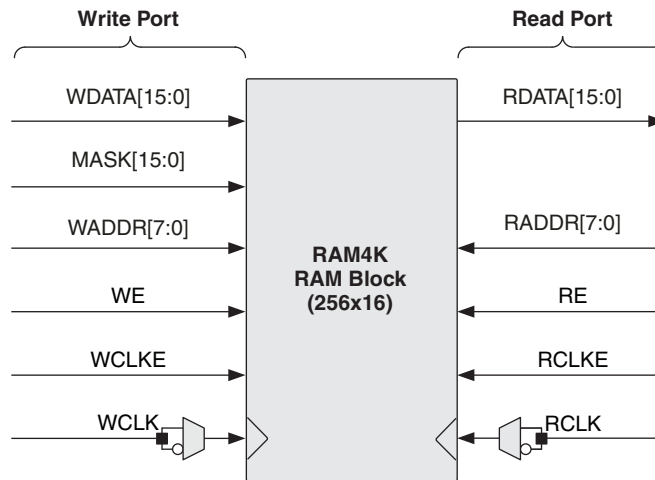

Table 2-5. EBR Signal Descriptions

Signal Name	Direction	Description
WDATA[15:0]	Input	Write Data input.
MASK[15:0]	Input	Masks write operations for individual data bit-lines. 0 = write bit 1 = do not write bit
WADDR[7:0]	Input	Write Address input. Selects one of 256 possible RAM locations.
WE	Input	Write Enable input.
WCLKE	Input	Write Clock Enable input.
WCLK	Input	Write Clock input. Default rising-edge, but with falling-edge option.
RDATA[15:0]	Output	Read Data output.
RADDR[7:0]	Input	Read Address input. Selects one of 256 possible RAM locations.
RE	Input	Read Enable input.
RCLKE	Input	Read Clock Enable input.
RCLK	Input	Read Clock input. Default rising-edge, but with falling-edge option.

For further information on the sysMEM EBR block, please refer to TN1250, [Memory Usage Guide for iCE40 Devices](#).

sysDSP

The iCE40 Ultra family provides an efficient sysDSP architecture that is very suitable for low-cost Digital Signal Processing (DSP) functions for mobile applications. Typical functions used in these applications are Multiply, Accumulate, and Multiply-Accumulate. The block can also be used for simple Add and Subtract functions.

iCE40 Ultra sysDSP Architecture Features

The iCE40 Ultra sysDSP supports many functions that include the following:

- Single 16-bit x 16-bit Multiplier, or two independent 8-bit x 8-bit Multipliers
- Optional independent pipeline control on Input Register, Output Register, and Intermediate Reg faster clock performance
- Single 32-bit Accumulator, or two independent 16-bit Accumulators
- Single 32-bit, or two independent 16-bit Adder/Subtractor functions, registered or asynchronous
- Cascadable to create wider Accumulator blocks

Figure 2-5 shows the block diagram of the sysDSP block. The block consists Multiplier section, with an bypassable Output register. The Input Register, Intermediate register between Multiplier and AC timing to achieve the highest performance.

Figure 2-5. sysDSP Functional Block Diagram (16-bit x 16-bit Multiply-Accumulate)

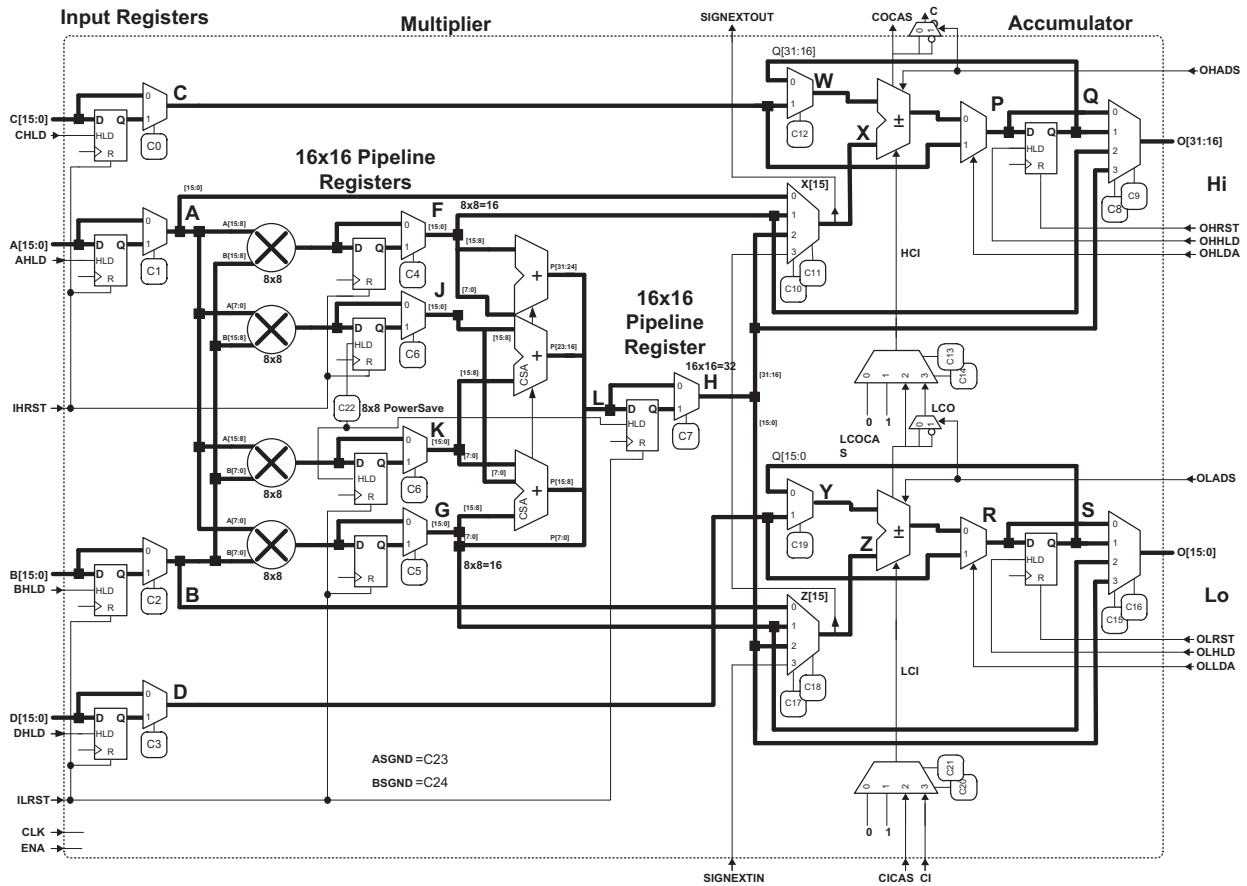

Table 2-6. sysDSP Input/Output List

Signal	Primitive Port Name	Width	Input / Output	Function	Default
CLK	CLK	1	Input	Clock Input. Applies to all clocked elements in the sysDSP block	
ENA	CE	1	Input	Clock Enable Input. Applies to all clocked elements in the sysDSP block. 0 = Not Enabled 1 = Enabled	0: Enabled
A[15:0]	A[15:0]	16	Input	Input to the A Register. Feeds the Multiplier or is a direct input to the Adder Accumulator	16'b0
B[15:0]	B[15:0]	16	Input	Input to the B Register. Feeds the Multiplier or is a direct input to the Adder Accumulator	16'b0
C[15:0]	C[15:0]	16	Input	Input to the C Register. It is a direct input to the Adder Accumulator	16'b0
D[15:0]	D[15:0]	16	Input	Input to the D Register. It is a direct input to the Adder Accumulator	16'b0
AHLD	AHOLD	1	Input	A Register Hold. 0 = Update 1 = Hold	0: Update
BHLD	BHOLD	1	Input	B Register Hold. 0 = Update 1 = Hold	0: Update
CHLD	CHOLD	1	Input	C Register Hold. 0 = Update 1 = Hold	0: Update
DHLD	DHOLD	1	Input	D Register Hold. 0 = Update 1 = Hold	0: Update
IHRST	IRSTTOP	1	Input	Reset input to A and C input registers, and the pipeline registers in the upper half of the Multiplier Section. 0 = No Reset 1 = Reset	0: No Reset
ILRST	IRSTBOT	1	Input	Reset input to B and D input registers, and the pipeline registers in the lower half of the Multiplier Section. It also resets the Multiplier result pipeline register. 0 = No Reset 1 = Reset	0: No Reset
O[31:0]	O[31:0]	32	Output	Output of the sysDSP block. This output can be: — O[31:0] – 32-bit result of 16x16 Multiplier or MAC — O[31:16] – 16-bit result of 8x8 upper half Multiplier or MAC — O[15:0] – 16-bit result of 8x8 lower half Multiplier or MAC	
OHHLD	OHOLDTOP	1	Input	High-order (upper half) Accumulator Register Hold. 0 = Update 1 = Hold	0: Update
OHRST	ORSTTOP	1	Input	Reset input to high-order (upper half) bits of the Accumulator Register. 0 = No Reset 1 = Reset	0: No Reset

Signal	Primitive Port Name	Width	Input / Output	Function	Default
OHLDA	OLOADTOP	1	Input	High-order (upper half) Accumulator Register Accumulate/Load control. 0 = Accumulate, register is loaded with Adder/Subtractor results 1 = Load, register is loaded with Input C or C Register	0: Accumulate
OHADS	ADDSUBTOP	1	Input	High-order (upper half) Accumulator Add or Subtract select. 0 = Add 1 = Subtract	0: Add
OLHLD	OHOLDBOT	1	Input	Low-order (lower half) Accumulator Register Hold. 0 = Update 1 = Hold	0: Update
OLRST	ORSTBOT	1	Input	Reset input to Low-order (lower half) bits of the Accumulator Register. 0 = No Reset 1 = Reset	0: No Reset
OLLDA	OLOADBOT	1	Input	Low-order (lower half) Accumulator Register Accumulate/Load control. 0 = Accumulate, register is loaded with Adder/Subtractor results 1 = Load, register is loaded with Input C or C Register	0: Accumulate
OLADS	ADDSUBBOT	1	Input	Low-order (lower half) Accumulator Add or Subtract select. 0 = Add 1 = Subtract	0: Add
CICAS	ACCUMCI	1	Input	Cascade Carry/Borrow input from previous sysDSP block	
CI	CI	1	Input	Carry/Borrow input from lower logic tile	
COCAS	ACCUMCO	1	Output	Cascade Carry/Borrow output to next sysDSP block	
CO	CO	1	Output	Carry/Borrow output to higher logic tile	
SIGNEXTIN	SIGNEXTIN	1	Input	Sign extension input from previous sysDSP block	
SIGNEXTOUT	SIGNEXTOUT	1	Output	Sign extension output to next sysDSP block	

The iCE40 Ultra sysDSP can support the following functions:

- 8-bit x 8-bit Multiplier
- 16-bit x 16-bit Multiplier
- 16-bit Adder/Subtractor
- 32-bit Adder/Subtractor
- 16-bit Accumulator
- 32-bit Accumulator
- 8-bit x 8-bit Multiply-Accumulate
- 16-bit x 16-bit Multiply-Accumulate

Figure 2-6 shows the path for an 8-bit x 8-bit Multiplier using the upper half of sysDSP block.

Figure 2-6. sysDSP 8-bit x 8-bit Multiplier

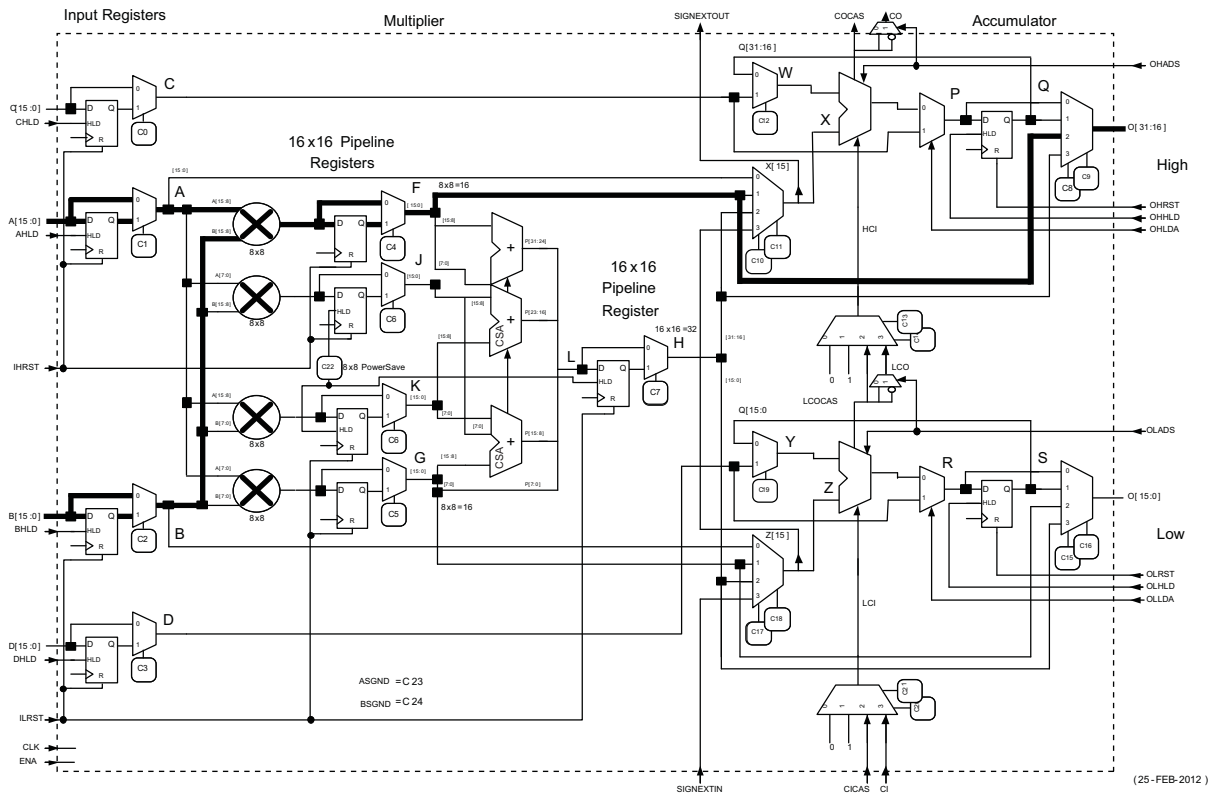

Figure 2-7 shows the path for an 16-bit x 16-bit Multiplier using the upper half of sysDSP block.

sysIO Buffer Banks

iCE40 Ultra devices have up to three I/O banks with independent V_{CCIO} rails. The configuration SPI interface signals are powered by SPI_V_{CCIO1} . Please refer to the [Pin Information Summary](#) table.

Programmable I/O (PIO)

The programmable logic associated with an I/O is called a PIO. The individual PIOs are connected to their respective sysIO buffers and pads. The PIOs are placed on the top and bottom of the devices.

Figure 2-8. I/O Bank and Programmable I/O Cell

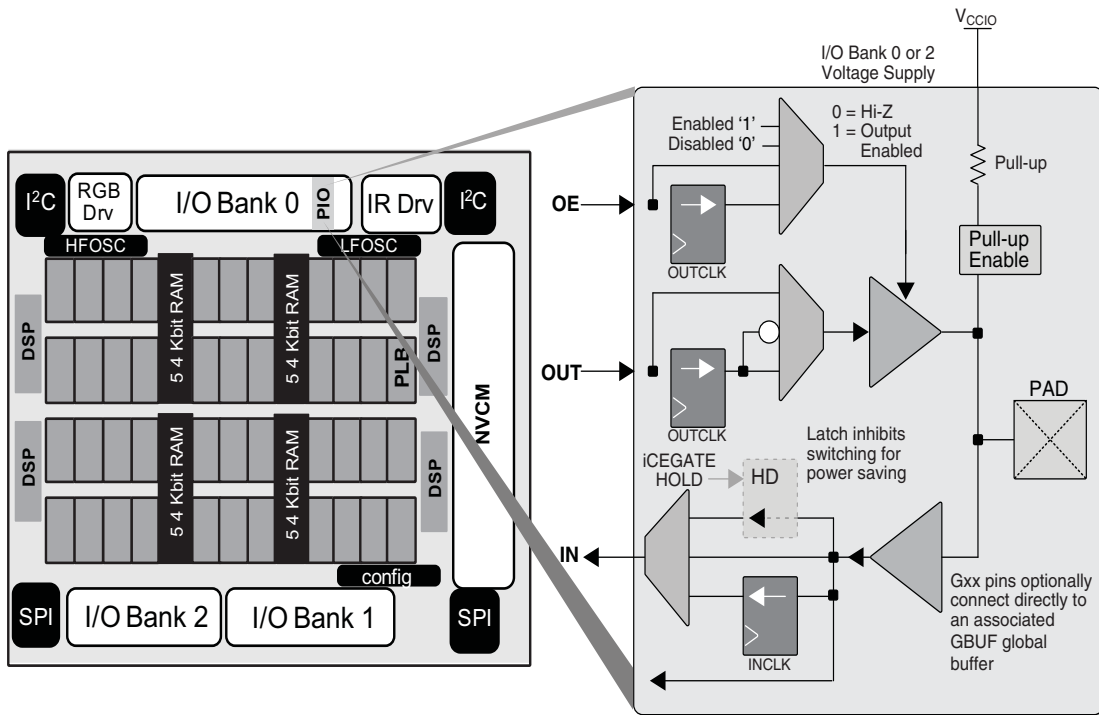

The PIO contains three blocks: an input register block, output register block iCEGate™ and tri-state register block. To save power, the optional iCEGate™ latch can selectively freeze the state of individual, non-registered inputs within an I/O bank. Note that the freeze signal is common to the bank. These blocks can operate in a variety of modes along with the necessary clock and selection logic.

Input Register Block

The input register blocks for the PIOs on all edges contain registers that can be used to condition high-speed interface signals before they are passed to the device core.

Output Register Block

The output register block can optionally register signals from the core of the device before they are passed to the sysIO buffers.

Figure 2-9 shows the input/output register block for the PIOs.

Figure 2-9. iCE I/O Register Block Diagram

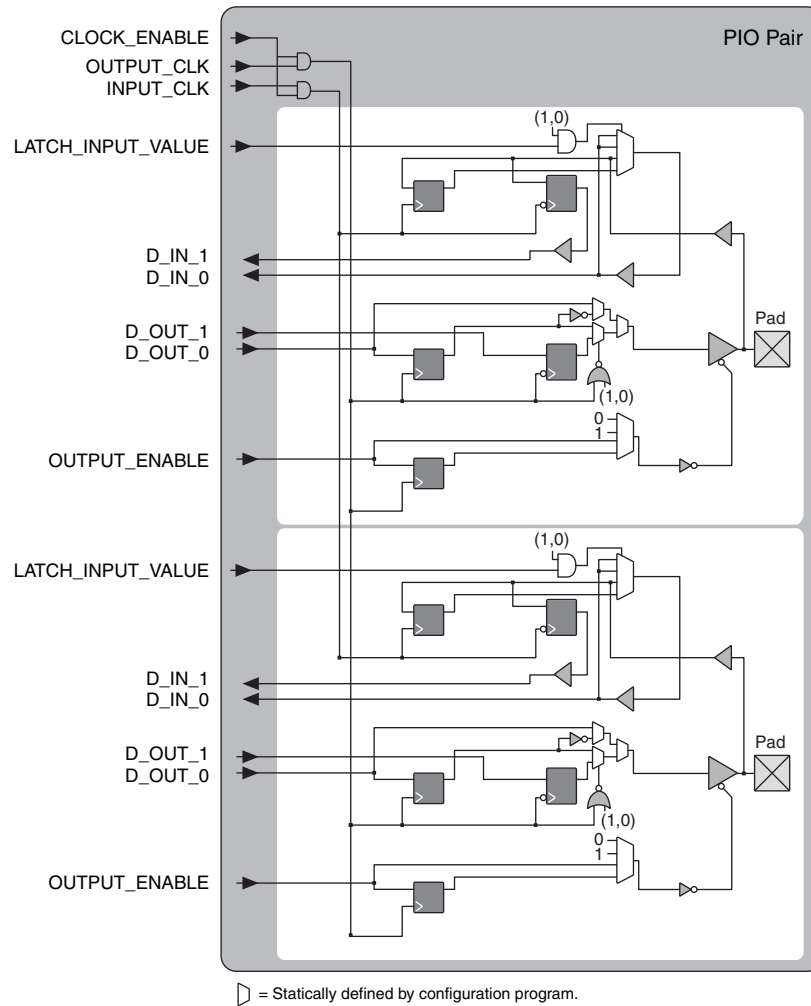

Table 2-7. PIO Signal List

Pin Name	I/O Type	Description
OUTPUT_CLK	Input	Output register clock
CLOCK_ENABLE	Input	Clock enable
INPUT_CLK	Input	Input register clock
OUTPUT_ENABLE	Input	Output enable
D_OUT_0/1	Input	Data from the core
D_IN_0/1	Output	Data to the core
LATCH_INPUT_VALUE	Input	Latches/holds the Input Value

sysIO Buffer

Each I/O is associated with a flexible buffer referred to as a sysIO buffer. These buffers are arranged around the periphery of the device in groups referred to as banks. The sysIO buffers allow users to implement a wide variety of standards that are found in today's systems with LVCMOS interfaces.

Typical I/O Behavior During Power-up

The internal power-on-reset (POR) signal is deactivated when V_{CC} , SPI_V_{CCIO1} , and V_{PP_2V5} reach the level defined in the Power-On-Reset Voltage table in the [DC and Switching Characteristics](#) section of this data sheet. After the POR signal is deactivated, the FPGA core logic becomes active. You must ensure that all V_{CCIO} banks are active with valid input logic levels to properly control the output logic states of all the I/O banks that are critical to the application. The default configuration of the I/O pins in a device prior to configuration is tri-stated with a weak pull-up to V_{CCIO} . The I/O pins maintain the pre-configuration state until V_{CC} , SPI_V_{CCIO1} , and V_{PP_2V5} reach the defined levels. The I/Os take on the software user-configured settings only after POR signal is deactivated and the device performs a proper download/configuration. Unused I/Os are automatically blocked and the pull-up termination is disabled.

Supported Standards

The iCE40 Ultra sysIO buffer supports both single-ended input/output standards, and used as differential comparators. The buffer supports the LVCMOS 1.8, 2.5, and 3.3 V standards. The buffer has individually configurable options for bus maintenance (weak pull-up or none).

Table 2-8 and Table 2-9 show the I/O standards (together with their supply and reference voltages) supported by the iCE40 Ultra devices.

Differential Comparators

The iCE40 Ultra devices provide differential comparator on pairs of I/O pins. These comparators are useful in some mobile applications. Please refer to the [Pin Information Summary](#) section to locate the corresponding paired I/Os with differential comparators.

Table 2-8. Supported Input Standards

Input Standard	V_{CCIO} (Typical)		
	3.3 V	2.5 V	1.8 V
Single-Ended Interfaces			
LVCMOS33	✓		
LVCMOS25		✓	
LVCMOS18			✓

Table 2-9. Supported Output Standards

Output Standard	V_{CCIO} (Typical)
Single-Ended Interfaces	
LVCMOS33	3.3 V
LVCMOS25	2.5 V
LVCMOS18	1.8 V

On-Chip Oscillator

The iCE40 Ultra devices feature two different frequency Oscillator. One is tailored for low-power operation that runs at low frequency (LFOSC). Both Oscillators are controlled with internally generated current.

The LFOSC runs at nominal frequency of 10 kHz. The high frequency oscillator (HFOSC) runs at a nominal frequency of 48 MHz, divisible to 24 MHz, 12 MHz, or 6 MHz by user option. The LFOSC can be used to perform all always-on functions, with the lowest power possible. The HFOSC can be enabled when the always-on functions detect a condition that would need to wake up the system to perform higher frequency functions.

User I²C IP

The iCE40 Ultra devices have two I²C IP cores. Either of the two cores can be configured either as an I²C master or as an I²C slave. The pins for the I²C interface are not pre-assigned. User can use any General Purpose I/O pins.

In each of the two cores, there are options to delay the either the input or the output, or both, by 50 ns nominal, using dedicated on-chip delay elements. This provides an easier interface with any external I²C components.

When the IP core is configured as master, it will be able to control other devices on the I²C bus through the pre-assigned pin interface. When the core is configured as the slave, the device will be able to provide I/O expansion to an I²C Master. The I²C cores support the following functionality:

- Master and Slave operation
- 7-bit and 10-bit addressing
- Multi-master arbitration support
- Clock stretching
- Up to 400 kHz data transfer speed
- General Call support
- Optionally delaying input or output data, or both

For further information on the User I²C, please refer to TN1274, [iCE40 SPI/I2C Hardened IP Usage Guide](#).

User SPI IP

The iCE40 Ultra devices have two SPI IP cores. The pins for the SPI interface are not pre-assigned. User can use any General Purpose I/O pins. Both SPI IP cores can be configured as a SPI master or as a slave. When the SPI IP core is configured as a master, it controls the other SPI enabled devices connected to the SPI Bus. When SPI IP core is configured as a slave, the device will be able to interface to an external SPI master.

The SPI IP core supports the following functions:

- Configurable Master and Slave modes
- Full-Duplex data transfer
- Mode fault error flag with CPU interrupt capability
- Double-buffered data register
- Serial clock with programmable polarity and phase
- LSB First or MSB First Data Transfer

For further information on the User SPI, please refer to TN1274, [iCE40 SPI/I2C Hardened IP Usage Guide](#).

High Current LED Drive I/O Pins

The iCE40 Ultra family devices offer multiple high current LED drive outputs in each device in the family to allow the iCE40 Ultra product to drive LED signals directly on mobile applications.

There are three outputs on each device that can sink up to 24 mA current. These outputs are open-drain outputs, and provides sinking current to an LED connecting to the positive supply. These three outputs are designed to drive the RGB LEDs, such as the service LED found in a lot of mobile devices. An embedded RGB PWM IP is also offered in the family. This RGB drive current is user programmable from 4 mA to 24 mA, in increments of 4 mA. This output functions as General Purpose I/O with open-drain when the high current LED drive is not needed.

There is one output on each device that can sink up to 500 mA current. This output is open-drain, and provides sinking current to drive an external IR LED connecting to the positive supply. This IR drive current is user programmable from 50 mA to 500 mA in increments of 50 mA. This output functions as General Purpose I/O with open-drain when the high current LED drive is not needed.

Embedded PWM IP

To provide an easier usage of the RGB high current drivers to drive RGB LED, a Pulse-Width Modulator IP can be embedded into the user design. This PWM IP provides the flexibility for user to dynamically change the settings on the ON-time duration, OFF-time duration, and ability to turn the LED lights on and off gradually with user set breath-on and breath-off time.

For additional information on the embedded PWM IP, please refer to TN1288, [iCE40 LED Driver Usage Guide](#).

Non-Volatile Configuration Memory

All iCE40 Ultra devices provide a Non-Volatile Configuration Memory (NVCM) block which can be used to configure the device.

For more information on the NVCM, please refer to TN1248, [iCE40 Programming and Configuration](#).

iCE40 Ultra Programming and Configuration

This section describes the programming and configuration of the iCE40 Ultra family.

Device Programming

The NVCM memory can be programmed through the SPI port. The SPI port is located in Bank 1, using SPI_V_{CCIO1} power supply.

Device Configuration

There are various ways to configure the Configuration RAM (CRAM), using SPI port, including:

- From a SPI Flash (Master SPI mode)
- System microprocessor to drive a Serial Slave SPI port (SSPI mode)

For more details on configuring the iCE40 Ultra, please see TN1248, [iCE40 Programming and Configuration](#).

Power Saving Options

The iCE40 Ultra devices feature iCEGate and PLL low power mode to allow users to meet the static and dynamic power requirements of their applications. Table 2-10 describes the function of these features.

Table 2-10. iCE40 Ultra Power Saving Features Description

Device Subsystem	Feature Description
PLL	When LATCHINPUTVALUE is enabled, puts the PLL into low-power mode; PLL output held static at last input clock value.
iCEGate	To save power, the optional iCEGate latch can selectively freeze the state of individual, non-registered inputs within an I/O bank. Registered inputs are effectively frozen by their associated clock or clock-enable control.



iCE40 Ultra Family Data Sheet

DC and Switching Characteristics

June 2016

Data Sheet DS1048

Absolute Maximum Ratings^{1, 2, 3}

Supply Voltage V_{CC}	-0.5 V to 1.42 V
Output Supply Voltage V_{CCIO}	-0.5 V to 3.60 V
NVCM Supply Voltage V_{PP_2V5}	-0.5 V to 3.60 V
PLL Supply Voltage V_{CCPLL}	-0.5 V to 1.42 V
I/O Tri-state Voltage Applied	-0.5 V to 3.60 V
Dedicated Input Voltage Applied	-0.5 V to 3.60 V
Storage Temperature (Ambient)	-65 °C to 150 °C
Junction Temperature (T_J)	-65 °C to 125 °C

1. Stress above those listed under the “Absolute Maximum Ratings” may cause permanent damage to the device. Functional operation of the device at these or any other conditions above those indicated in the operational sections of this specification is not implied.
2. Compliance with the Lattice [Thermal Management](#) document is required.
3. All voltages referenced to GND.

Recommended Operating Conditions¹

Symbol	Parameter	Min.	Max.	Units	
V_{CC} ¹	Core Supply Voltage	1.14	1.26	V	
V_{PP_2V5}	VPP_2V5 NVCM Programming and Operating Supply Voltage	Slave SPI Configuration	1.71 ⁴	3.46	V
		Master SPI Configuration	2.30	3.46	V
		Configuration from NVCM	2.30	3.46	V
		NVCM Programming	2.30	3.00	V
V_{CCIO} ^{1, 2, 3}	I/O Driver Supply Voltage	V_{CCIO_0} , SPI_ V_{CCIO1} , V_{CCIO_2}	1.71	3.46	V
V_{CCPLL}	PLL Supply Voltage	1.14	1.26	V	
t_{JCOM}	Junction Temperature Commercial Operation	0	85	°C	
t_{JIND}	Junction Temperature Industrial Operation	-40	100	°C	
t_{PROG}	Junction Temperature NVCM Programming	10.00	30.00	°C	

1. Like power supplies must be tied together if they are at the same supply voltage and they meet the power up sequence requirement. Please refer to [Power-Up Supply Sequencing](#) section. V_{CC} and V_{CCPLL} are recommended to tie to same supply with an RC-based noise filter between them. Please refer to TN1252, [iCE40 Hardware Checklist](#).
2. See recommended voltages by I/O standard in subsequent table.
3. V_{CCIO} pins of unused I/O banks should be connected to the V_{CC} power supply on boards.
4. V_{PP_2V5} can, optionally, be connected to a 1.8 V (+/-5%) power supply in Slave SPI Configuration mode subject to the condition that none of the HFOSC/LFOSC and RGB LED / IR LED driver features are used. Otherwise, V_{PP_2V5} must be connected to a power supply with a minimum 2.30 V level.

Power Supply Ramp Rates^{1, 2}

Symbol	Parameter	Min.	Max.	Units
t_{RAMP}	Power supply ramp rates for all power supplies.	0.6	10	V/ms

1. Assumes monotonic ramp rates.
2. Power up sequence must be followed. Please refer to [Power-Up Supply Sequencing](#) section.

Power-On Reset

All iCE40 Ultra devices have on-chip Power-On-Reset (POR) circuitry to ensure proper initialization of the device. Only three supply rails are monitored by the POR circuitry as follows: (1) V_{CC} , (2) SPI_V_{CCIO1} and (3) V_{PP_2V5} . All other supply pins have no effect on the power-on reset feature of the device. Note that all supply voltage pins must be connected to power supplies for normal operation (including device configuration).

Power-Up Supply Sequencing

It is recommended to bring up the power supplies in the following order. Note that there is no specified timing delay between the power supplies, however, there is a requirement for each supply to reach a level of 0.5V, or higher, before any subsequent power supplies in the sequence are applied.

1. V_{CC} and V_{CCPLL} should be the first two supplies to be applied. Note that these two supplies can be tied together subject to the recommendation to include a RC-based noise filter on the V_{CCPLL} (Please refer to TN1252, [iCE40 Hardware Checklist](#).)
2. SPI_V_{CCIO1} should be the next supply, and can be applied any time after the previous supplies (V_{CC} and V_{CCPLL}) have reached as level of 0.5 V or higher.
3. V_{PP_2V5} should be the next supply, and can be applied any time after previous supplies (V_{CC} , V_{CCPLL} and SPI_V_{CCIO1}) have reached a level of 0.5 V or higher.
4. **Other Supplies** (V_{CCIO0} and V_{CCIO2}) do not affect device power-up functionality, and they can be applied any time after the initial power supplies (V_{CC} and V_{CCPLL}) have reached a level of 0.5 V or greater.

There is no power down sequence required. However, when partial power supplies are powered down, it is required the above sequence to be followed when these supplies are repowered up again.

External Reset

When all power supplies have reached to their minimum operating voltage defined in Minimum Operation Condition Table, it is required to either keep $CRESET_B$ LOW, or toggle $CRESET_B$ from HIGH to LOW, for a duration of t_{CRESET_B} , and release it to go HIGH, to start configuration download from either the internal NVCM or the external Flash memory.

Figure 3-1 shows Power-Up sequence when SPI_V_{CCIO1} and V_{PP_2V5} are connected separately, and the $CRESET_B$ signal triggers configuration download. Figure 3-2 shows when SPI_V_{CCIO1} and V_{PP_2V5} connected together.

All power supplies should be powered up during configuration. Before and during configuration, the I/Os are held in tri-state. I/Os are released to user functionality once the device has finished configuration.

Figure 3-1. Power Up Sequence with SPI_V_{CCIO1} and V_{PP_2V5} Not Connected Together

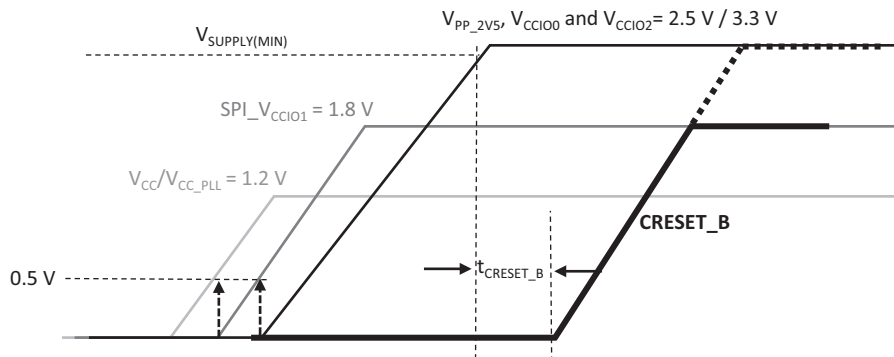
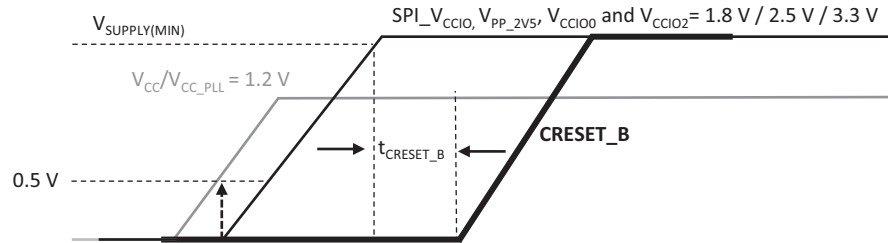

Figure 3-2. Power Up Sequence with All Supplies Connected Together



Power-On-Reset Voltage Levels¹

Symbol	Parameter	Min.	Max.	Units	
V _{PORUP}	Power-On-Reset ramp-up trip point (circuit monitoring V _{CC} , SPI_V _{CCI01} , V _{PP_2V5})	V _{CC}	0.62	0.92	V
		SPI_V _{CCI01}	0.87	1.50	V
		V _{PP_2V5}	0.90	1.53	V
V _{PORDN}	Power-On-Reset ramp-down trip point (circuit monitoring V _{CC} , SPI_V _{CCI01} , V _{PP_2V5})	V _{CC}	—	0.79	V
		SPI_V _{CCI01}	—	1.50	V
		V _{PP_2V5}	—	1.53	V

1. These POR trip points are only provided for guidance. Device operation is only characterized for power supply voltages specified under recommended operating conditions.

ESD Performance

Please contact Lattice Semiconductor for additional information.

DC Electrical Characteristics

Over Recommended Operating Conditions

Symbol	Parameter	Condition	Min.	Typ.	Max.	Units
I _{IL} , I _{IH} ^{1,3,4}	Input or I/O Leakage	0V < V _{IN} < V _{CCI0} + 0.2 V	—	—	+/-10	μA
C ₁	I/O Capacitance, excluding LED Drivers ²	V _{CCI0} = 3.3 V, 2.5 V, 1.8 V V _{CC} = Typ., V _{IO} = 0 to V _{CCI0} + 0.2 V	—	6	—	pF
C ₂	Global Input Buffer Capacitance ²	V _{CCI0} = 3.3 V, 2.5 V, 1.8 V V _{CC} = Typ., V _{IO} = 0 to V _{CCI0} + 0.2 V	—	6	—	pF
C ₃	RGB Pin Capacitance ²	V _{CC} = Typ., V _{IO} = 0 to 3.5 V	—	15	—	pF
C ₄	IRLED Pin Capacitance ²	V _{CC} = Typ., V _{IO} = 0 to 3.5 V	—	53	—	pF
V _{HYST}	Input Hysteresis	V _{CCI0} = 1.8 V, 2.5 V, 3.3 V	—	200	—	mV
I _{PU}	Internal PIO Pull-up Current	V _{CCI0} = 1.8 V, 0=<V _{IN} <=0.65 V _{CCI0}	-3	—	-31	μA
		V _{CCI0} = 2.5 V, 0=<V _{IN} <=0.65 V _{CCI0}	-8	—	-72	μA
		V _{CCI0} = 3.3 V, 0=<V _{IN} <=0.65 V _{CCI0}	-11	—	-128	μA

1. Input or I/O leakage current is measured with the pin configured as an input or as an I/O with the output driver tri-stated. It is not measured with the output driver active. Internal pull-up resistors are disabled.

2. T_J 25 °C, f = 1.0 MHz.

3. Please refer to V_{IL} and V_{IH} in the sysIO Single-Ended DC Electrical Characteristics table of this document.

4. Input pins are clamped to V_{CCI0} and GND by a diode. When input is higher than V_{CCI0} or lower than GND, the Input Leakage current will be higher than the I_{IL} and I_{IH}.

Supply Current ^{1, 2, 3, 4, 5}

Symbol	Parameter	Typ. $V_{CC} = 1.2 V^4$	Units
$I_{CCSTDBY}$	Core Power Supply Static Current	71	μA
$I_{PP2V5STDBY}$	V_{PP_2V5} Power Supply Static Current	0.55	μA
$I_{SPI_VCCIO1STDBY}$	SPI_V_{CCIO1} Power Supply Static Current	0.5	μA
$I_{CCIOSTDBY}$	V_{CCIO} Power Supply Static Current	0.5	μA
I_{CCPEAK}	Core Power Supply Startup Peak Current	8.0	mA
$I_{PP_2V5PEAK}$	V_{PP_2V5} Power Supply Startup Peak Current	7.0	mA
$I_{SPI_VCCIO1PEAK}$	SPI_V_{CCIO1} Power Supply Startup Peak Current	9.0	mA
$I_{CCIOPEAK}$	V_{CCIO} Power Supply Startup Peak Current	7.5	mA

- Assumes blank pattern with the following characteristics: all outputs are tri-stated, all inputs are configured as LVCMOS and held at V_{CCIO} or GND, on-chip PLL is off. For more detail with your specific design, use the Power Calculator tool. Power specified with master SPI configuration mode. Other modes may be up to 25% higher.
- Frequency = 0 MHz.
- $T_J = 25^\circ C$, power supplies at nominal voltage, on devices processed in nominal process conditions.
- Does not include pull-up.
- Startup Peak Currents are measured with decoupling capacitance of 0.1 μF , 10 nF, and 1 nF to the power supply. Higher decoupling capacitance causes higher current.

User I²C Specifications

Parameter Symbol	Parameter Description	spec (STD Mode)			spec (FAST Mode)			Units
		Min	Typ	Max	Min	Typ	Max	
f_{SCL}	Maximum SCL clock frequency	—	—	100	—	—	400	kHz
t_{HI}	SCL clock HIGH Time	4	—	—	0.6	—	—	μs
t_{LO}	SCL clock LOW Time	4.7	—	—	1.3	—	—	μs
$t_{SU,DAT}$	Setup time (DATA)	250	—	—	100	—	—	ns
$t_{HD,DAT}$	Hold time (DATA)	0	—	—	0	—	—	ns
$t_{SU,STA}$	Setup time (START condition)	4.7	—	—	0.6	—	—	μs
$t_{HD,STA}$	Hold time (START condition)	4	—	—	0.6	—	—	μs
$t_{SU,STO}$	Setup time (STOP condition)	4	—	—	0.6	—	—	μs
t_{BUF}	Bus free time between STOP and START	4.7	—	—	1.3	—	—	μs
$t_{CO,DAT}$	SCL LOW to DATAOUT valid	—	—	3.4	—	—	0.9	μs

User SPI Specifications ^{1, 2}

Parameter Symbol	Parameter Description	Min	Typ	Max	Units
f_{MAX}	Maximum SCK clock frequency	—	—	45	MHz

- All setup and hold time parameters on external SPI interface are design-specific and, therefore, generated by the Lattice Design Software tools. These parameters include the following:
 - $t_{SUmaster}$ master Setup time (master mode)
 - $t_{HOLDmaster}$ master Hold time (master mode)
 - $t_{SUslave}$ slave Setup time (slave mode)
 - $t_{HOLDslave}$ slave Hold time (slave mode)
 - $t_{SCK2OUT}$ SCK to out (slave mode)
- The SCLK duty cycle needs to be specified in the Lattice Design Software as a timing constraint in order to ensure proper timing check on SCLK HIGH and LOW (t_{HI} , t_{LO}) time.

Internal Oscillators (HFOSC, LFOSC)¹

Parameter		Parameter Description	Spec/Recommended			Units
Symbol	Conditions		Min	Typ	Max	
f _{CLKHF}	Commercial Temp	HFOSC clock frequency (t _J = 0 °C–85 °C)	–10%	48	10%	MHz
	Industrial Temp	HFOSC clock frequency (t _J = –40 °C–100 °C)	–20%	48	20%	MHz
f _{CLKLF}		LFOSC CLKK clock frequency	–10%	10	10%	kHz
DCH _{CLKHF}	Commercial Temp	HFOSC clock frequency (t _J = 0 °C–85 °C)	45	50	55	%
	Industrial Temp	HFOSC clock frequency (t _J = –45 °C–100 °C)	40	50	60	%
DCH _{CLKLF}		LFOSC Duty Cycle (Clock High Period)	45	50	55	%
Tsync_on		Oscillator output synchronizer delay	—	—	5	Cycles
Tsync_off		Oscillator output disable delay	—	—	5	Cycles

1. Glitchless enabling and disabling OSC clock outputs.

sysIO Recommended Operating Conditions

Standard	V _{CCIO} (V)		
	Min.	Typ.	Max.
LVC MOS 3.3	3.14	3.3	3.46
LVC MOS 2.5	2.37	2.5	2.62
LVC MOS 1.8	1.71	1.8	1.89

sysIO Single-Ended DC Electrical Characteristics

Input/ Output Standard	V _{IL}		V _{IH}		V _{OL} Max. (V)	V _{OH} Min. (V)	I _{OL} Max. (mA)	I _{OH} Max. (mA)
	Min. (V)	Max. (V)	Min. (V)	Max. (V)				
LVC MOS 3.3	–0.3	0.8	2.0	V _{CCIO} + 0.2V	0.4	V _{CCIO} – 0.4	8	–8
					0.2	V _{CCIO} – 0.2	0.1	–0.1
LVC MOS 2.5	–0.3	0.7	1.7	V _{CCIO} + 0.2V	0.4	V _{CCIO} – 0.4	6	–6
					0.2	V _{CCIO} – 0.2	0.1	–0.1
LVC MOS 1.8	–0.3	0.35V _{CCIO}	0.65V _{CCIO}	V _{CCIO} + 0.2V	0.4	V _{CCIO} – 0.4	4	–4
					0.2	V _{CCIO} – 0.2	0.1	–0.1

Differential Comparator Electrical Characteristics

Parameter Symbol	Parameter Description	Test Conditions	Min.	Max.	Units
V _{REF}	Reference Voltage to compare, on V _{INM}	V _{CCIO} = 2.5 V	0.25	V _{CCIO} – 0.25 V	V
V _{DIFFIN_H}	Differential input HIGH (V _{INP} – V _{INM})	V _{CCIO} = 2.5 V	250	—	mV
V _{DIFFIN_L}	Differential input LOW (V _{INP} – V _{INM})	V _{CCIO} = 2.5 V	—	–250	mV
I _{IN}	Input Current, V _{INP} and V _{INM}	V _{CCIO} = 2.5 V	–10	10	μA

Typical Building Block Function Performance^{1, 2}

Pin-to-Pin Performance (LVCMOS25)

Function	Timing	Units
Basic Functions		
16-bit decoder	16.5	ns
4:1 MUX	18.0	ns
16:1 MUX	19.5	ns

Register-to-Register Performance

Function	Timing	Units
Basic Functions		
16:1 MUX	110	MHz
16-bit adder	100	MHz
16-bit counter	100	MHz
64-bit counter	40	MHz
Embedded Memory Functions		
256x16 Pseudo-Dual Port RAM	150	MHz

1. The above timing numbers are generated using the Lattice Design Software tool. Exact performance may vary with device and tool version. The tool uses internal parameters that have been characterized but are not tested on every device.
2. Under worst case operating conditions.

Derating Logic Timing

Logic timing provided in the following sections of the data sheet and the Lattice design tools are worst case numbers in the operating range. Actual delays may be much faster. Lattice design tools can provide logic timing numbers at a particular temperature and voltage.

Maximum sysIO Buffer Performance¹

I/O Standard	Max. Speed	Units
Inputs		
LVCMOS33	250	MHz
LVCMOS25	250	MHz
LVCMOS18	250	MHz
Outputs		
LVCMOS33	250	MHz
LVCMOS25	250	MHz
LVCMOS18	155	MHz

1. Measured with a toggling pattern

iCE40 Ultra Family Timing Adders

Over Recommended Commercial Operating Conditions^{1,2,3}

Buffer Type	Description	Timing (Typ.)	Units
Input Adjusters			
LVC MOS33	LVC MOS, $V_{CCIO} = 3.3\text{ V}$	0.18	ns
LVC MOS25	LVC MOS, $V_{CCIO} = 2.5\text{ V}$	0	ns
LVC MOS18	LVC MOS, $V_{CCIO} = 1.8\text{ V}$	0.19	ns
Output Adjusters			
LVC MOS33	LVC MOS, $V_{CCIO} = 3.3\text{ V}$	-0.12	ns
LVC MOS25	LVC MOS, $V_{CCIO} = 2.5\text{ V}$	0	ns
LVC MOS18	LVC MOS, $V_{CCIO} = 1.8\text{ V}$	1.32	ns

1. Timing adders are relative to LVC MOS25 and characterized but not tested on every device.
2. LVC MOS timing measured with the load specified in Switching Test Condition table.
3. Commercial timing numbers are shown.

iCE40 Ultra External Switching Characteristics

Over Recommended Commercial Operating Conditions

Parameter	Description	Device	Min	Max	Units
Clocks					
Global Clocks					
$f_{\text{MAX_GBUF}}$	Frequency for Global Buffer Clock network	All devices	—	185	MHz
$t_{\text{W_GBUF}}$	Clock Pulse Width for Global Buffer	All devices	2	—	ns
$t_{\text{SKEW_GBUF}}$	Global Buffer Clock Skew Within a Device	All devices	—	500	ps
Pin-LUT-Pin Propagation Delay					
t_{PD}	Best case propagation delay through one LUT logic	All devices	—	9.0	ns
General I/O Pin Parameters (Using Global Buffer Clock without PLL)¹					
$t_{\text{SKEW_IO}}$	Data bus skew across a bank of IOs	All devices	—	410	ps
t_{CO}	Clock to Output – PIO Output Register	All devices	—	9.0	ns
t_{SU}	Clock to Data Setup – PIO Input Register	All devices	-0.5	—	ns
t_{H}	Clock to Data Hold – PIO Input Register	All devices	5.55	—	ns
General I/O Pin Parameters (Using Global Buffer Clock with PLL)					
t_{COPLL}	Clock to Output – PIO Output Register	All Devices	—	2.9	ns
t_{SUPLL}	Clock to Data Setup – PIO Input Register	All Devices	5.9	—	ns
t_{HPLL}	Clock to Data Hold – PIO Input Register	All Devices	-0.6	—	ns

1. All the data is from the worst case condition.

sysCLOCK PLL Timing

Over Recommended Operating Conditions

Parameter	Descriptions	Conditions	Min.	Max.	Units
f_{IN}	Input Clock Frequency (REFERENCECLK, EXTFEEDBACK)		10	133	MHz
f_{OUT}	Output Clock Frequency (PLLOUT)		16	275	MHz
f_{VCO}	PLL VCO Frequency		533	1066	MHz
f_{PFD}	Phase Detector Input Frequency		10	133	MHz
AC Characteristics					
t_{DT}	Output Clock Duty Cycle		40	60	%
t_{PH}	Output Phase Accuracy		—	+/-12	deg
$t_{OPJIT}^{1,5,6}$	Output Clock Period Jitter	$f_{OUT} \geq 100$ MHz	—	450	ps p-p
		$f_{OUT} < 100$ MHz	—	0.05	UIPP
	Output Clock Cycle-to-cycle Jitter	$f_{OUT} \geq 100$ MHz	—	750	ps p-p
		$f_{OUT} < 100$ MHz	—	0.10	UIPP
	Output Clock Phase Jitter	$f_{PFD} \geq 25$ MHz	—	275	ps p-p
		$f_{PFD} < 25$ MHz	—	0.05	UIPP
t_W	Output Clock Pulse Width	At 90% or 10%	1.33	—	ns
$t_{LOCK}^{2,3}$	PLL Lock-in Time		—	50	μ s
t_{UNLOCK}	PLL Unlock Time		—	50	ns
t_{IPJIT}^4	Input Clock Period Jitter	$f_{PFD} \geq 20$ MHz	—	1000	ps p-p
		$f_{PFD} < 20$ MHz	—	0.02	UIPP
t_{STABLE}^3	LATCHINPUTVALUE LOW to PLL Stable		—	500	ns
$t_{STABLE_PW}^3$	LATCHINPUTVALUE Pulse Width		100	—	ns
t_{RST}	RESET Pulse Width		10	—	ns
t_{RSTREC}	RESET Recovery Time		10	—	μ s
$t_{DYNAMIC_WD}$	DYNAMICDELAY Pulse Width		100	—	VCO Cycles

1. Period jitter sample is taken over 10,000 samples of the primary PLL output with a clean reference clock. Cycle-to-cycle jitter is taken over 1000 cycles. Phase jitter is taken over 2000 cycles. All values per JESD65B.
2. Output clock is valid after t_{LOCK} for PLL reset and dynamic delay adjustment.
3. At minimum f_{PFD} . As the f_{PFD} increases the time will decrease to approximately 60% the value listed.
4. Maximum limit to prevent PLL unlock from occurring. Does not imply the PLL will operate within the output specifications listed in this table.
5. The jitter values will increase with loading of the PLD fabric and in the presence of SSO noise.

sysDSP Timing

Over Recommended Operating Conditions

Parameter	Description	Min.	Max.	Units
$f_{MAX8x8SMULT}$	Max frequency signed MULT8x8 bypassing pipeline register	50	—	MHz
$f_{MAX16x16SMULT}$	Max frequency signed MULT16x16 bypassing pipeline register	50	—	MHz

SPI Master or NVCM Configuration Time^{1, 2}

Symbol	Parameter	Conditions	Max.	Units
t _{CONFIG}	POR/CRESET_B to Device I/O Active	All devices – Low Frequency (Default)	95	ms
		All devices – Medium frequency	35	ms
		All devices – High frequency	18	ms

1. Assumes sysMEM Block is initialized to an all zero pattern if they are used.
2. The NVCM download time is measured with a fast ramp rate starting from the maximum voltage of POR trip point.

sysCONFIG Port Timing Specifications

Symbol	Parameter	Conditions	Min.	Typ.	Max.	Units
All Configuration Modes						
t _{CRESET_B}	Minimum CRESET_B LOW pulse width required to restart configuration, from falling edge to rising edge		200	—	—	ns
t _{DONE_IO}	Number of configuration clock cycles after CDONE goes HIGH before the PIO pins are activated		49	—	—	Clock Cycles
Slave SPI						
t _{CR_SCK}	Minimum time from a rising edge on CRESET_B until the first SPI WRITE operation, first SPI_XCK clock. During this time, the iCE40 Ultra device is clearing its internal configuration memory		1200	—	—	μs
f _{MAX}	CCLK clock frequency	Write	1	—	25	MHz
		Read ¹	—	15	—	MHz
t _{CCLKH}	CCLK clock pulsewidth HIGH		20	—	—	ns
t _{CCLKL}	CCLK clock pulsewidth LOW		20	—	—	ns
t _{STSU}	CCLK setup time		12	—	—	ns
t _{STH}	CCLK hold time		12	—	—	ns
t _{STCO}	CCLK falling edge to valid output		13	—	—	ns
Master SPI³						
f _{MCLK}	MCLK clock frequency	Low Frequency (Default)	7.0	12.0	17.0	MHz
		Medium Frequency ²	21.0	33.0	45.0	MHz
		High Frequency ²	33.0	53.0	71.0	MHz
t _{MCLK}	CRESET_B HIGH to first MCLK edge		1200	—	—	μs
t _{SU}	CCLK setup time ⁴		9.9	—	—	ns
t _{HD}	CCLK hold time		1	—	—	ns

1. Supported with 1.2 V V_{CC} and at 25 °C.
2. Extended range f_{MAX} Write operations support up to 53 MHz with 1.2 V V_{CC} and at 25 °C.
3. t_{SU} and t_{HD} timing must be met for all MCLK frequency choices.
4. For considerations of SPI Master Configuration Mode, please refer to TN1248, [iCE40 Programming and Configuration](#).

RGB LED and IR LED Drive

Symbol	Parameter	Min.	Max.	Units
ILED_ACCURACY	RGB0, RGB1, RGB2 Sink Current Accuracy to selected current @ $V_{LEDOUT} \geq 0.5 \text{ V}$	-12	+12	%
ILED_MATCH	RGB0, RGB1, RGB2 Sink Current Matching among the 3 outputs @ $V_{LEDOUT} \geq 0.5 \text{ V}$	-5	+5	%
IIR_ACCURACY	IR LED Sink Current Accuracy to selected current @ $V_{IROUT} \geq 0.8 \text{ V}$	-14	+14	%

Switching Test Conditions

Figure 3-3 shows the output test load used for AC testing. The specific values for resistance, capacitance, voltage, and other test conditions are shown in Table 3-1.

Figure 3-3. Output Test Load, LVCMOS Standards

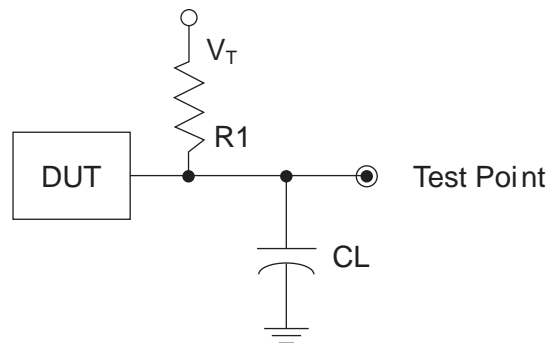

Table 3-1. Test Fixture Required Components, Non-Terminated Interfaces

Test Condition	R_1	C_L	Timing Reference	V_T
LVCMOS settings (L -> H, H -> L)	∞	0 pF	LVCMOS 3.3 = 1.5 V	—
			LVCMOS 2.5 = $V_{CCIO}/2$	—
			LVCMOS 1.8 = $V_{CCIO}/2$	—
LVCMOS 3.3 (Z -> H)	188	0 pF	1.5 V	V_{OL}
LVCMOS 3.3 (Z -> L)			1.5 V	V_{OH}
Other LVCMOS (Z -> H)			$V_{CCIO}/2$	V_{OL}
Other LVCMOS (Z -> L)			$V_{CCIO}/2$	V_{OH}
LVCMOS (H -> Z)			$V_{OH} - 0.15 \text{ V}$	V_{OL}
LVCMOS (L -> Z)			$V_{OL} - 0.15 \text{ V}$	V_{OH}

Note: Output test conditions for all other interfaces are determined by the respective standards.

Signal Descriptions

Signal Name	Function	I/O	Description	
Power Supplies				
V _{CC}	Power	—	Core Power Supply	
V _{CCIO_0} , SPI_V _{CCIO1} , V _{CCIO_2}	Power	—	Power for I/Os in Bank 0, 1 and 2.	
V _{PP_2V5}	Power	—	Power for NVCM programming and operations.	
V _{CCPLL}	Power	—	Power for PLL	
GND	GROUND	—	Ground	
GND_LED	GROUND	—	Ground for LED drivers. Should connect to GND on board.	
Configuration				
CRESETB	Configuration	I	Configuration Reset, active LOW. No internal pull-up resistor. Either actively driven externally or connect an 10 kOhm pull-up to V _{CCIO_1} .	
CDONE	Configuration	I/O	Configuration Done. Includes a weak pull-up resistor to SPI_V _{CCIO1} .	
	General I/O	I/O	In user mode, after configuration, this pin can be programmed as general I/O in user function.	
Config SPI				
Primary	Secondary			
CRESETB	—	Configuration	I	Configuration Reset, active LOW. No internal pull-up resistor. Either actively driven externally or connect an 10 kOhm pull-up to SPI_V _{CCIO1} .
PIOB_xx	CDONE	Configuration	I/O	Configuration Done. Includes a weak pull-up resistor to SPI_V _{CCIO1} .
		General I/O	I/O	In user mode, after configuration, this pin can be programmed as general I/O in user function.
Config SPI				
Primary	Secondary			
PIOB_34a	SPI_SCK	Configuration	I/O	This pin is shared with device configuration. During configuration: In Master SPI mode, this pin outputs the clock to external SPI memory. In Slave SPI mode, this pin inputs the clock from external processor.
		General I/O	I/O	In user mode, after configuration, this pin can be programmed as general I/O in user function
PIOB_32a	SPI_SDO	Configuration	Output	This pin is shared with device configuration. During configuration: In Master SPI mode, this pin outputs the command data to external SPI memory. In Slave SPI mode, this pin connects to the MISO pin of the external processor.
		General I/O	I/O	In user mode, after configuration, this pin can be programmed as general I/O in user function.

Signal Name		Function	I/O	Description
PIOB_33b	SPI_SI	Configuration	Input	This pin is shared with device configuration. During configuration: In Master SPI mode, this pin receives data from external SPI memory. In Slave SPI mode, this pin connects to the MOSI pin of the external processor.
		General I/O	I/O	In user mode, after configuration, this pin can be programmed as general I/O in user function.
PIOB_35b	SPI_SS_B	Configuration	I/O	This pin is shared with device configuration. During configuration: In Master SPI mode, this pin outputs to the external SPI memory. In Slave SPI mode, this pin inputs from the external processor.
		General I/O	I/O	In user mode, after configuration, this pin can be programmed as general I/O in user function.
Global Signals				
Primary	Secondary			
PIOT_46b	G0	General I/O	I/O	In user mode, after configuration, this pin can be programmed as general I/O in user function
		Global	Input	Global input used for high fanout, or clock/reset net. The G0 pin drives the GBUF0 global buffer
PIOT_45a	G1	General I/O	I/O	In user mode, after configuration, this pin can be programmed as general I/O in user function
		Global	Input	Global input used for high fanout, or clock/reset net. The G1 pin drives the GBUF1 global buffer
PIOT_25b	G3	General I/O	I/O	In user mode, after configuration, this pin can be programmed as general I/O in user function
		Global	Input	Global input used for high fanout, or clock/reset net. The G3 pin drives the GBUF3 global buffer
PIOT_12a	G4	General I/O	I/O	In user mode, after configuration, this pin can be programmed as general I/O in user function
		Global	Input	Global input used for high fanout, or clock/reset net. The G4 pin drives the GBUF4 global buffer
PIOT_11b	G5	General I/O	I/O	In user mode, after configuration, this pin can be programmed as general I/O in user function
		Global	Input	Global input used for high fanout, or clock/reset net. The G5 pin drives the GBUF5 global buffer
PIOB_3b	G6	General I/O	I/O	In user mode, after configuration, this pin can be programmed as general I/O in user function
		Global	Input	Global input used for high fanout, or clock/reset net. The G6 pin drives the GBUF6 global buffer
LED Signals				
RGB0		General I/O	Open-Drain I/O	In user mode, with user's choice, this pin can be programmed as open drain I/O in user function
		LED	Open-Drain Output	In user mode, with user's choice, this pin can be programmed as open drain 24mA output to drive external LED
RGB1		General I/O	Open-Drain I/O	In user mode, with user's choice, this pin can be programmed as open drain I/O in user function
		LED	Open-Drain Output	In user mode, with user's choice, this pin can be programmed as open drain 24mA output to drive external LED

Signal Name	Function	I/O	Description
RGB2	General I/O	Open-Drain I/O	In user mode, with user's choice, this pin can be programmed as open drain I/O in user function
	LED	Open-Drain Output	In user mode, with user's choice, this pin can be programmed as open drain 24mA output to drive external LED
IRLED	General I/O	Open-Drain I/O	In user mode, with user's choice, this pin can be programmed as open drain I/O in user function
	LED	Open-Drain Output	In user mode, with user's choice, this pin can be programmed as open drain 500mA output to drive external LED
PIOT_xx	General I/O	I/O	In user mode, with user's choice, this pin can be programmed as I/O in user function in the top (xx = I/O location)
PIOB_xx	General I/O	I/O	In user mode, with user's choice, this pin can be programmed as I/O in user function in the bottom (xx = I/O location)

Pin Information Summary

Pin Type		iCE5LP1K			iCE5LP2K			iCE5LP4K		
		CM36	SWG36	SG48 ¹	CM36	SWG36	SG48 ¹	CM36	SWG36	SG48 ¹
General Purpose I/O Per Bank	Bank 0	12	5	17	12	5	17	12	5	17
	Bank 1	4	15	14	4	15	14	4	15	14
	Bank 2	10	6	8	10	6	8	10	6	8
Total General Purpose I/Os		26	26	39	26	26	39	26	26	39
V _{CC}		1	1	2	1	1	2	1	1	2
V _{CCIO}	Bank 0	1	1	1	1	1	1	1	1	1
	Bank 1	1	1	1	1	1	1	1	1	1
	Bank 2	1	1	1	1	1	1	1	1	1
V _{CCPLL}		1	1	1	1	1	1	1	1	1
V _{PP_2V5}		1	1	1	1	1	1	1	1	1
Dedicated Config Pins		1	1	2	1	1	2	1	1	2
GND		2	2	0	2	2	0	2	2	0
GND_LED		1	1	0	1	1	0	1	1	0
Total Balls		36	36	48	36	36	48	36	36	48

1. 48-pin QFN package (SG48) requires the package paddle to be connected to GND.

iCE5LP Part Number Description

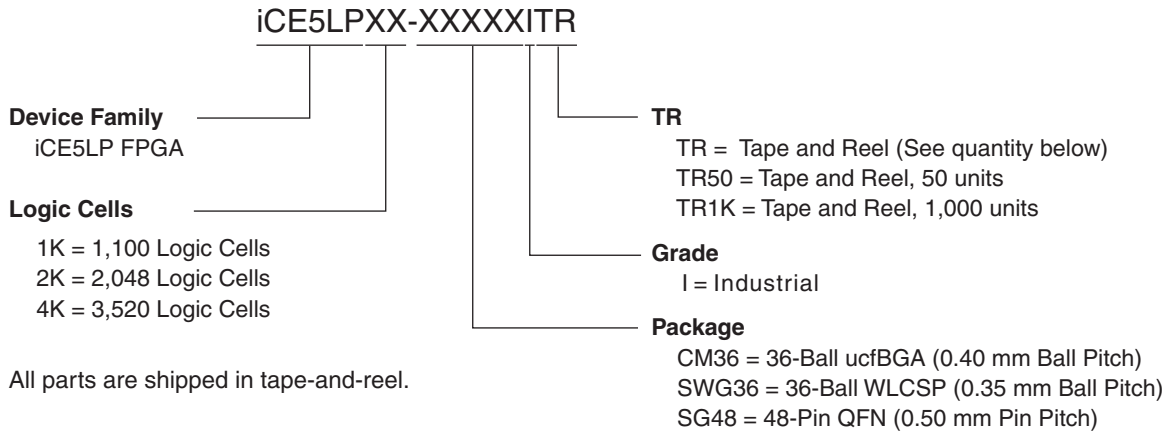

Tape and Reel Quantity

Package	TR Quantity
CM36	4,000
SWG36	5,000
SG48	2,000

Ordering Part Numbers

Industrial

Part Number	LUTs	Supply Voltage	Package	Pins	Temp.
iCE5LP1K-CM361TR	1100	1.2 V	Halogen-Free ucfBGA	36	IND
iCE5LP1K-CM361TR50	1100	1.2 V	Halogen-Free ucfBGA	36	IND
iCE5LP1K-CM361TR1K	1100	1.2 V	Halogen-Free ucfBGA	36	IND
iCE5LP1K-SWG361TR	1100	1.2 V	Halogen-Free WLCSP	36	IND
iCE5LP1K-SWG361TR50	1100	1.2 V	Halogen-Free WLCSP	36	IND
iCE5LP1K-SWG361TR1K	1100	1.2 V	Halogen-Free WLCSP	36	IND
iCE5LP1K-SG481TR	1100	1.2 V	Halogen-Free QFN	48	IND
iCE5LP1K-SG481TR50	1100	1.2 V	Halogen-Free QFN	48	IND
iCE5LP2K-CM361TR	2048	1.2 V	Halogen-Free ucfBGA	36	IND
iCE5LP2K-CM361TR50	2048	1.2 V	Halogen-Free ucfBGA	36	IND
iCE5LP2K-CM361TR1K	2048	1.2 V	Halogen-Free ucfBGA	36	IND
iCE5LP2K-SWG361TR	2048	1.2 V	Halogen-Free WLCSP	36	IND
iCE5LP2K-SWG361TR50	2048	1.2 V	Halogen-Free WLCSP	36	IND
iCE5LP2K-SWG361TR1K	2048	1.2 V	Halogen-Free WLCSP	36	IND
iCE5LP2K-SG481TR	2048	1.2 V	Halogen-Free QFN	48	IND
iCE5LP2K-SG481TR50	2048	1.2 V	Halogen-Free QFN	48	IND
iCE5LP4K-CM361TR	3520	1.2 V	Halogen-Free ucfBGA	36	IND
iCE5LP4K-CM361TR50	3520	1.2 V	Halogen-Free ucfBGA	36	IND
iCE5LP4K-CM361TR1K	3520	1.2 V	Halogen-Free ucfBGA	36	IND
iCE5LP4K-SWG361TR	3520	1.2 V	Halogen-Free WLCSP	36	IND
iCE5LP4K-SWG361TR50	3520	1.2 V	Halogen-Free WLCSP	36	IND
iCE5LP4K-SWG361TR1K	3520	1.2 V	Halogen-Free WLCSP	36	IND
iCE5LP4K-SG481TR	3520	1.2 V	Halogen-Free QFN	48	IND
iCE5LP4K-SG481TR50	3520	1.2 V	Halogen-Free QFN	48	IND

For Further Information

A variety of technical notes for the iCE40 Ultra family are available on the Lattice web site.

- [TN1248, iCE40 Programming and Configuration](#)
- [TN1274, iCE40 SPI/I2C Hardened IP Usage Guide](#)
- [TN1276, Advanced iCE40 SPI/I2C Hardened IP Usage Guide](#)
- [TN1250, Memory Usage Guide for iCE40 Devices](#)
- [TN1251, iCE40 sysCLOCK PLL Design and Usage Guide](#)
- [TN1252, iCE40 Hardware Checklist](#)
- [TN1288, iCE40 LED Driver Usage Guide](#)
- [TN1295, DSP Function Usage Guide for iCE40 Devices](#)
- [TN1296, iCE40 Oscillator Usage Guide](#)
- [iCE40 Ultra Pinout Files](#)
- [iCE40 Ultra Pin Migration Files](#)
- [Thermal Management](#) document
- [Lattice design tools](#)
- [Schematic Symbols](#)

Date	Version	Section	Change Summary
June 2016	2.0	Introduction	Updated General Description section. Changed “high current driver” to “high current IR driver”.
			Updated Features section. In Table 1-1, iCE40 Ultra Family Selection Guide, corrected HF Oscillator (48 kHz) to (48 MHz).
		Architecture	Updated Architecture Overview section. — Changed content to “The Programmable Logic Blocks (PLB) and sysMEM EBR blocks, are arranged in a two-dimensional grid with rows and columns. Each column has either PLB or EBR blocks.” — Changed “high current LED sink” to “high current RGB and IR LED sinks”.
			Updated sysCLOCK Phase Locked Loops (PLLs) section. Corrected V_{CCPLL} character format in Figure 2-3, PLL Diagram.
			Updated sysMEM Embedded Block RAM Memory section. Updated footnote in Table 2-4, sysMEM Block Configurations.
			Updated sysIO Buffer Banks section. — Changed statement to “The configuration SPI interface signals are powered by SPI_ V_{CCIO1} .” — Corrected V_{CCIO} character format in Figure 2-8, I/O Bank and Programmable I/O Cell.
			Updated Typical I/O Behavior During Power-up section. Modified text content.
			Updated Supported Standards section. Changed statement to “The iCE40 Ultra sysIO buffer supports both single-ended input/output standards, and used as differential comparators.”
			Updated On-Chip Oscillator section. Changed statement to “The high frequency oscillator (HFOSC) runs at a nominal frequency of 48 MHz, divisible to 24 MHz, 12 MHz, or 6 MHz by user option.”
			Updated section heading to High Current LED Drive I/O Pins . Changed “high current drive” to “high current LED drive”.
			Removed Power On Reset section.
			DC and Switching Characteristics
		Updated Recommended Operating Conditions section. — Corrected symbol character format. — Revised footnote 1. — Added footnote 4.	
		Updated Power Supply Ramp Rates section. Changed t_{RAMP} Max. value.	
		Added Power-On Reset section.	
		Updated section heading to Power-Up Supply Sequencing . Revised text content.	
		Added External Reset section.	
		Updated DC Electrical Characteristics section. Revised footnote 4.	

Date	Version	Section	Change Summary
			<p>Updated Supply Current section.</p> <ul style="list-style-type: none"> — Corrected $I_{PP2V5STDBY}$ parameter. — Added Typ. $V_{CC} = 1.2$ V values for I_{CCPEAK}, $I_{PP_2V5PEAK}$, $I_{SPI_VCCIO1PEAK}$, and $I_{CCIOPEAK}$. — Added footnote 5. — Corrected S_{PI_VCCIO1} character format.
			Updated User SPI Specifications section. Removed parameters and added footnotes.
			Updated Internal Oscillators (HFOSC, LFOSC) section. Added Commercial and Industrial Temp values for DCH_{CLKHF} .
			Updated sysIO Single-Ended DC Electrical Characteristics section. Removed footnote.
			Updated Register-to-Register Performance section. Modified footnotes.
			Updated iCE40 Ultra External Switching Characteristics section. Modified footnote.
			Updated sysCLOCK PLL Timing section. Reversed t_{OPJIT} conditions.
			<p>Updated sysCONFIG Port Timing Specifications section.</p> <ul style="list-style-type: none"> — Modified t_{CR_SCK} Min. value. — Added footnote 4 to t_{SU} parameter. — Modified t_{SU} Min. value. — Modified t_{HD} parameter.
			Updated section heading to RGB LED and IR LED Drive . Modified $I_{LED_ACCURACY}$ and $I_{IR_ACCURACY}$ parameters, Min. and Max. values.
		Pinout Information	<p>Updated Signal Descriptions section. Changed V_{CCIO_1} to S_{PI_VCCIO1} in the CDONE, CRESETB and PIOB_xx descriptions.</p> <p>Updated Pin Information Summary section.</p> <ul style="list-style-type: none"> — Corrected symbol character format. — Corrected V_{CPP_2V5} to V_{PP_2V5}.
	1.9	Introduction	Updated Features section. Updated BGA package to ucfBGA.
		DC and Switching Characteristics	Updated Differential Comparator Electrical Characteristics section. Corrected typo in V_{REF} Max. value.
		Pinout Information	<p>Updated Signal Descriptions section.</p> <ul style="list-style-type: none"> — Changed PIOB_12a to PIOB_xx — Changed SPI_CSN to SPI_SS_B and revised description when in Slave SPI mode. — Corrected minor typo errors. <p>Updated Pin Information Summary section. Added footnote to SG48.</p>
		Ordering Information	Updated iCE5LP Part Number Description section. Updated BGA package to ucfBGA.
			Updated Ordering Part Numbers section. Updated BGA package to ucfBGA.
June 2015	1.8	DC and Switching Characteristics	Updated Internal Oscillators (HFOSC, LFOSC) section. Removed decimals.
		Ordering Information	<p>Updated iCE5LP Part Number Description section.</p> <ul style="list-style-type: none"> — Added TR items. — Corrected formatting errors. <p>Updated Ordering Part Numbers section. Updated CM36 and SG48 packages.</p>

Date	Version	Section	Change Summary
April 2015	1.7	Architecture	Updated sysDSP section. Revised the following figures: — Figure 2-5, sysDSP Functional Block Diagram (16-bit x 16-bit Multiply-Accumulate) — Figure 2-6, sysDSP 8-bit x 8-bit Multiplier — Figure 2-7, DSP 16-bit x 16-bit Multiplier
		Ordering Information	Updated iCE5LP Part Number Description section. Added TR items.
			Updated Ordering Part Numbers section. Added CM36, SW36 and SG48 part numbers.
March 2015	1.6	Introduction	Updated Features section. — Added BGA and QFN packages in Flexible Logic Architecture. — Added USB 3.1 Type C Cable Detect / Power Delivery Applications in Applications. — Updated Table 1-1, iCE40 Ultra Family Selection Guide. Added 36-ball ucfBGA and 48-ball QFN packages. Changed subheading to Total User I/O Count. Changed RBW IP to PWM IP. Deleted footnotes.
		DC and Switching Characteristics	Updated Power-up Sequence section. Indicated all devices in second paragraph.
			Updated sysIO Single-Ended DC Electrical Characteristics section. Changed LVCMOS 3.3 and LVCMOS 2.5 V _{OH} Min. (V) from 0.5 to 0.4.
			Replaced the Differential Comparator Electrical Characteristics table.
		Pinout Information	Updated Pin Information Summary section. — Added CM36 and SG48 values. — Changed CRESET_B to Dedicated Config Pins.
		Ordering Information	Updated iCE5LP Part Number Description section. — Added CM36 and SG48 package. — Added TR items.
			Updated Ordering Part Numbers section. Added CM36, SW36 and SG48 part numbers.
October 2014	1.5	Introduction	Updated Features section. — Removed 26 I/O pins for 36-pin WLCSP under Flexible Logic Architecture. — Changed form factor to 2.078 mm x 2.078 mm. — Updated Table 1-1, iCE40 Ultra Family Selection Guide. Removed 20-Ball WLCSP.
			Updated Introduction section. Changed form factor to 2.078 mm x 2.078 mm.
		Architecture	Updated sysCLOCK Phase Locked Loops (PLLs) section. Removed note in heading regarding sysCLOCK PLL support.
		DC and Switching Characteristics	Updated Recommended Operating Conditions section. Removed footnote on sysCLOCK PLL support.
			Updated Power-up Sequence section. Removed information on 20-pin WLCSP.
		Pinout Information	Updated Signal Descriptions section. Removed references 20-pin WLCSP.
			Updated Pin Information Summary section. Removed references to UWG20 values.
		Ordering Information	Updated iCE5LP Part Number Description section. Removed 20-ball WLCSP.
			Updated Ordering Part Numbers section. Removed UWG20 part numbers.
		Further Information	Added technical note references.

Date	Version	Section	Change Summary
August 2014	1.4	All	Removed Preliminary document status.
		Introduction	Updated General Description section. Added information on high current driver.
			Updated Features section. — Changed standby current typical to as low as 71 μ A. — Changed feature to Embedded Memory. — Updated Table 1-1, iCE40 Ultra Family Selection Guide. Added NVCM and Embedded PWM IP rows. Added (MULT16 with 32-bit Accumulator) to DSP Block. Added Total I/O (Dedicated I/O) Count data.
			General update to Introduction section.
		Architecture	Updated Architecture Overview section. — Revised and added information on sysIO banks. — Updated reference for embedded PWM IP.
Updated iCE40 Ultra Programming and Configuration section. — Changed SPI1 to SPI. — Changed VCCIO_1 to SPI_VCCIO1.			
		DC and Switching Characteristics	Updated Absolute Maximum Ratings section. Changed PLL Supply Voltage VCCPLL value.
			Updated Recommended Operating Conditions section. Added footnote to VCCPLL.
			Updated Power-up Sequence section. General update.
			Updated Power-On-Reset Voltage Levels section. Changed the V_{PORUP} V_{CC} Max. value.
			Updated DC Electrical Characteristics section. Added C_3 and C_4 information.
			Updated Supply Current section. — Completed Typ. $V_{CC} = 1.2$ V4 data. — Changed symbols to $I_{SPI_VCCIO1STDBY}$ and $I_{SPI_VCCIO1PEAK}$. — Added information to footnote 3.
			Updated Internal Oscillators (HFOSC, LFOSC) section. General update.
			Updated iCE40 Ultra External Switching Characteristics section. Added Max. value for t_{COPLL} . Added Min. values for t_{SUPLL} and t_{HPLL} .
			Updated sysCLOCK PLL Timing section. Added Max. value for t_{OPJIT} .
			Updated sysCONFIG Port Timing Specifications section. — Added T_{SU} and T_{HD} information. — Added footnote 3 to Master SPI.
			Updated High Current LED and IR LED Drive section. Updated Min. value.
			July 2014
Introduction	Updated Features section. Adjusted Ultra-low Power Devices standby current.		
DC and Switching Characteristics	Updated AC/DC specifications numbers.		

Date	Version	Section	Change Summary
June 2014	1.2	All	Product name changed to iCE40 Ultra.
		Introduction	Updated Table 1-1, iCE40 Ultra Family Selection Guide. Removed 30-ball WLCSP.
		DC and Switching Characteristics	Updated values in the following sections: — Supply Current — Internal Oscillators (HFOSC, LFOSC) — Power Supply Ramp Rates — Power-On-Reset Voltage Levels — SPI Master or NVCM Configuration Time
			Indicated TBD for values to be determined.
		Pinout Information	Updated Signal Descriptions section. Removed 30-pin WLCSP.
			Updated Pin Information Summary section. Removed SWG30 values.
		Ordering Information	Updated iCE5LP Part Number Description section. Removed 30-ball WLCSP.
Updated Ordering Part Numbers section. Removed SWG30 and UWG30 part numbers.			
May 2014	01.1	Introduction	Updated General Description, Features, and Introduction sections. Removed hardened RGB PWM IP information.
		Architecture	Updated Architecture Overview section. Removed the RGB IP block in Figure 2-1, iCE5LP-4K Device, Top View, Figure 2-8, I/O Bank and Programmable I/O, and in the text content.
			Updated High Current Drive I/O Pins section. Removed hardened RGB PWM IP information.
			Updated Power On Reset section. Removed content on Vccio_2 power down option.
			Replaced RGB PWM Block section with Embedded PWM IP section.
DC and Switching Characteristics	Removed RGB PWM Block Timing section.		
April 2014	01.0	All	Initial release.

Looking for pricing, stock, or lifecycle information?

Click below to explore more details on WIN SOURCE:

- [View ICE5LP4K-CM36ITR50 on WIN SOURCE](#)
- [Lattice Semiconductor Corporation Information](#)

Optimize Your Supply Chain with WIN SOURCE Solutions

- ✓ Global Sourcing Solution
- ✓ Obsolete Management
- ✓ Cost Control Management
- ✓ Shortage Management
- ✓ Alternative Solution
- ✓ Excess Inventory Management