

---

---

## Universal High-Brightness LED Driver

---

---

### Features

- Switch mode controller for single switch LED drivers
- Enhanced drop-in replacement to the HV9910
- Open loop peak current controller
- Internal 8.0 to 450V linear regulator
- Constant frequency or constant off-time operation
- Linear and PWM dimming capability
- Requires few external components for operation

### Applications

- DC/DC or AC/DC LED driver applications
- RGB backlighting LED driver
- Back lighting of flat panel displays
- General purpose constant current source
- Signage and decorative LED lighting
- Chargers

### Description

HV9910B is an open loop, current mode control, LED driver IC. This IC can be programmed to operate in either a constant frequency or constant off-time mode. It includes an 8.0 - 450V linear regulator which allows it to work from a wide range of input voltages without the need for an external low voltage supply. HV9910B includes a PWM-dimming input that can accept an external control signal with a duty ratio of 0 - 100% and a frequency of up to a few kilohertz. It also includes a 0 - 250mV linear dimming input which can be used for linear dimming of the LED current.

HV9910B is ideally suited for buck LED drivers. Since the HV9910B operates in open loop current mode control, the controller achieves good output current regulation without the need for any loop compensation. PWM dimming response is limited only by the rate of rise and fall of the inductor current, enabling very fast rise and fall times. HV9910B requires only three external components, apart from the power stage, to produce a controlled LED current. This makes HV9910B an ideal solution for low cost LED drivers.

# HV9910B

## Package Type

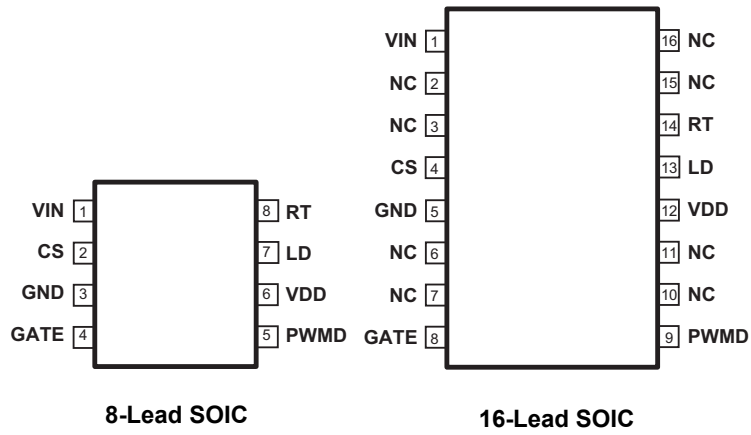

See [Table 2-1](#) for pin information

## Typical Application Circuit

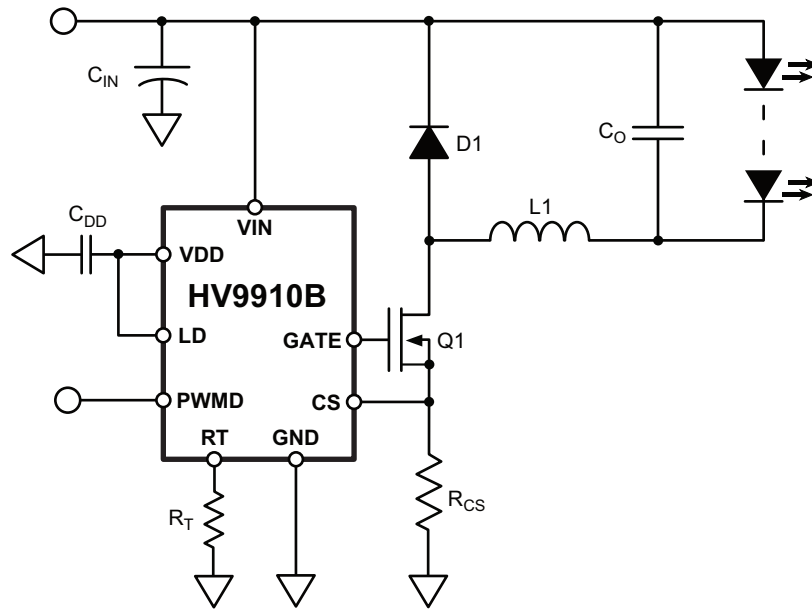

## 1.0 ELECTRICAL CHARACTERISTICS

### ABSOLUTE MAXIMUM RATINGS

$V_{IN}$ to GND.....	-0.5V to +470V
$V_{DD}$ to GND.....	12V
CS, LD, PWMD, GATE, RT to GND.....	-0.3V to ( $V_{DD} + 0.3V$ )
Operating temperature.....	-40°C to +125°C
Storage temperature.....	-65°C to +150°C
Continuous power dissipation ( $T_A = +25^\circ\text{C}$ )	
8-lead SOIC.....	630 mW
16-lead SOIC.....	1300 mW

**Note:** Stresses above those listed under “Absolute Maximum Ratings” may cause permanent damage to the device. This is a stress rating only and functional operation of the device at those or any other conditions, above those indicated in the operational listings of this specification, is not implied. Exposure to maximum rating conditions for extended periods may affect device reliability.

### 1.1 ELECTRICAL SPECIFICATIONS

**TABLE 1-1: ELECTRICAL CHARACTERISTICS (SHEET 1 OF 2)<sup>1</sup>**

Symbol	Parameter	Note	Min	Typ	Max	Units	Conditions
<b>Input</b>							
$V_{INDC}$	Input DC supply voltage range <sup>2</sup>	3	8.0	-	450	V	DC input voltage
$I_{INSD}$	Shut-down mode supply current	3	-	0.5	1.0	mA	Pin PWMD to GND
<b>Internal Regulator</b>							
$V_{DD}$	Internally regulated voltage	-	7.25	7.5	7.75	V	$V_{IN} = 8.0V$ , $I_{DD(ext)} = 0$ , 500pF at GATE; $R_T = 226k\Omega$ , PWMD = $V_{DD}$
$\Delta V_{DD, line}$	Line regulation of $V_{DD}$	-	0	-	1.0	V	$V_{IN} = 8.0 - 450V$ , $I_{DD(ext)} = 0$ , 500pF at GATE; $R_T = 226k\Omega$ , PWMD = $V_{DD}$
$\Delta V_{DD, load}$	Load regulation of $V_{DD}$	-	0	-	100	mV	$I_{DD(ext)} = 0 - 1.0mA$ , 500pF at GATE; $R_T = 226k\Omega$ , PWMD = $V_{DD}$
UVLO	$V_{DD}$ undervoltage lockout threshold	3	6.45	6.7	6.95	V	$V_{DD}$ rising
$\Delta UVLO$	$V_{DD}$ undervoltage lockout hysteresis	-	-	500	-	mV	$V_{DD}$ falling
$I_{IN,MAX}$	Current that the regulator can supply before IC goes into UVLO	4	5.0	-	-	mA	$V_{IN} = 8.0V$
<b>PWM Dimming</b>							
$V_{EN(lo)}$	Pin PWMD input low voltage	3	-	-	0.8	V	$V_{IN} = 8.0 - 450V$
$V_{EN(hi)}$	Pin PWMD input high voltage	3	2.0	-	-	V	$V_{IN} = 8.0 - 450V$
$R_{EN}$	Pin PWMD pull-down resistance at PWMD	-	50	100	150	k $\Omega$	$V_{PWMD} = 5.0V$

# HV9910B

**TABLE 1-1: ELECTRICAL CHARACTERISTICS (CONTINUED) (SHEET 2 OF 2)<sup>1</sup>**

Symbol	Parameter	Note	Min	Typ	Max	Units	Conditions
<b>Current Sense Comparator</b>							
$V_{CS,TH}$	Current sense pull-in threshold voltage	-	225	250	275	mV	$-40^{\circ}\text{C} < T_A < +85^{\circ}\text{C}$
			213	250	287		$T_A < +125^{\circ}\text{C}$
$V_{OFFSET}$	Offset voltage for LD comparator	3	-12	-	12	mV	
$T_{BLANK}$	Current sense blanking interval	-	150	215	280	ns	$0 < T_A < +85^{\circ}\text{C}$ , $V_{LD} = V_{DD}$ , $V_{CS} = V_{CS,TH} + 50\text{mV}$ after $T_{BLANK}$
		-	145	215	315		$-40 < T_A < +125^{\circ}\text{C}$ , $V_{LD} = V_{DD}$ , $V_{CS} = V_{CS,TH} + 50\text{mV}$ after $T_{BLANK}$
$t_{DELAY}$	Delay to output	-	-	80	150	ns	$V_{LD} = V_{DD}$ , $V_{CS} = V_{CS,TH} + 50\text{mV}$ after $T_{BLANK}$
<b>Oscillator</b>							
$f_{OSC}$	Oscillator frequency	-	20	25	30	kHz	$R_T = 1.00\text{M}\Omega$
		-	80	100	120		$R_T = 226\text{k}\Omega$
<b>Gate Driver</b>							
$I_{SOURCE}$	GATE sourcing current	-	165	-	-	mA	$V_{GATE} = 0\text{V}$ , $V_{DD} = 7.5\text{V}$
$I_{SINK}$	GATE sinking current	-	165	-	-	mA	$V_{GATE} = V_{DD}$ , $V_{DD} = 7.5\text{V}$
$t_{RISE}$	GATE output rise time	-	-	30	50	ns	$C_{GATE} = 500\text{pF}$ , $V_{DD} = 7.5\text{V}$
$t_{FALL}$	GATE output fall time	-	-	30	50	ns	$C_{GATE} = 500\text{pF}$ , $V_{DD} = 7.5\text{V}$

- 1 Specifications are  $T_A = 25^{\circ}\text{C}$ ,  $V_{IN} = 15\text{V}$  unless otherwise noted.
- 2 Also limited by package-power dissipation limit; Whichever is lower.
- 3 Applies over the full operating ambient temperature range of  $-40^{\circ}\text{C} < T_A < +125^{\circ}\text{C}$ .
- 4 For design guidance only

**TABLE 1-2: THERMAL RESISTANCE**

Package	$\theta_{ja}$
8-Lead SOIC	101°C/W
16-Lead SOIC	83°C/W

## 2.0 PIN DESCRIPTION

The locations of the pins are listed in [Package Type](#).

**TABLE 2-1: PIN DESCRIPTION**

Pin #		Function	Description
8-Lead SOIC	16-Lead SOIC		
1	1	VIN	Input of an 8.0 - 450V linear regulator.
2	4	CS	Current sense pin used to sense the FET current by means of an external sense resistor. When this pin exceeds the lower of either the internal 250mV or the voltage at the LD pin, the GATE output goes low.
3	5	GND	Ground return for all internal circuitry. This pin must be electrically connected to the ground of the power train.
4	8	GATE	Output GATE driver for an external N-channel power MOSFET.
5	9	PWMD	PWM dimming input of the IC. When this pin is pulled to GND, the GATE driver is turned off. When the pin is pulled high, the GATE driver operates normally.
6	12	VDD	Power supply for all internal circuits. It must be bypassed with a low ESR capacitor to GND ( $\geq 0.1\mu\text{F}$ ).
7	13	LD	Linear dimming input and sets the current sense threshold as long as the voltage at the pin is less than 250mV (typ).
8	14	RT	Sets the oscillator frequency. When a resistor is connected between RT and GND, the HV9910B operates in constant frequency mode. When the resistor is connected between RT and GATE, the IC operates in constant off-time mode.
-	2, 3, 6, 7, 10, 11, 15, 16	NC	No connection

# HV9910B

## 3.0 APPLICATION INFORMATION

HV9910B is optimized to drive buck LED drivers using open-loop, peak current mode control. This method of control enables fairly accurate LED current control without the need for high side current sensing or the design of any closed loop controllers. The IC uses very few external components and enables both Linear and PWM-dimming of the LED current.

A resistor connected to the RT pin programs the frequency of operation (or the off-time). The oscillator produces pulses at regular intervals. These pulses set the SR flip-flop in the HV9910B which causes the GATE driver to turn on. The same pulses also start the blanking timer, which inhibits the reset input of the SR flip-flop and prevent false turn-offs due to the turn-on spike. When the FET turns on, the current through the inductor starts ramping up. This current flows through the external sense resistor  $R_{CS}$  and produces a ramp voltage at the CS pin. The comparators are constantly comparing the CS pin voltage to both the voltage at the LD pin and the internal 250mV. Once the blanking timer is complete, the output of these comparators is allowed to reset the flip-flop. When the output of either one of the two comparators goes high, the flip flop is reset and the GATE output goes low. The GATE goes low until the SR flip-flop is set by the oscillator. Assuming a 30% ripple in the inductor, the current sense resistor  $R_{CS}$  can be set using:

$$R_{CS} = \frac{0.25V(\text{or } V_{LD})}{1.15 \cdot I_{LED}(A)}$$

Constant frequency peak current mode control has an inherent disadvantage – at duty cycles greater than 0.5, the control scheme goes into subharmonic oscillations. To prevent this, an artificial slope is typically added to the current sense waveform. This slope compensation scheme will affect the accuracy of the LED current in the present form. However, a constant off-time peak current control scheme does not have this problem and can easily operate at duty cycles greater than 0.5. This control scheme also gives inherent input voltage rejection, making the LED current almost insensitive to input voltage variations. However, this scheme leads to variable frequency operation and the frequency range depends greatly on the input and output voltage variation. HV9910B makes it easy to switch between the two modes of operation by changing one connection (see [Section 3.3 “Oscillator”](#)).

### 3.1 Input Voltage Regulator

HV9910B can be powered directly from its VIN pin and can work from 8.0 - 450VDC at its VIN pin. When a voltage is applied at the VIN pin, the HV9910B maintains a constant 7.5V at the VDD pin. This voltage is used to power the IC and any external resistor dividers needed

to control the IC. The VDD pin must be bypassed by a low-ESR capacitor to provide a low impedance path for the high frequency current of the output GATE driver.

HV9910B can also be operated by supplying a voltage at the VDD pin greater than the internally regulated voltage. This will turn off the internal linear regulator of the IC and the HV9910B will operate directly off the voltage supplied at the VDD pin. Please note that this external voltage at the VDD pin should not exceed 12V.

Although the VIN pin of the HV9910B is rated up to 450V, the actual maximum voltage that can be applied is limited by the power dissipation in the IC. For example, if an 8-pin SOIC (junction to ambient thermal resistance  $R_{\theta j-a} = 128^{\circ}\text{C}/\text{W}$ ) HV9910B draws about  $I_{IN} = 2.0\text{mA}$  from the VIN pin, and has a maximum allowable temperature rise of the junction temperature limited to about  $\Delta T = 100^{\circ}\text{C}$ , the maximum voltage at the VIN pin would be:

$$V_{IN(\text{MAX})} = \frac{\Delta T}{R_{\theta j-a}} \cdot \frac{1}{I_{IN}} = \frac{100^{\circ}\text{C}}{128^{\circ}\text{C}/\text{W}} \cdot \frac{1}{2\text{mA}} = 390\text{V}$$

In these cases, to operate the HV9910B from higher input voltages, a Zener diode can be added in series with the VIN pin to divert some of the power loss from the HV9910B to the Zener diode. In the above example, using a 100V Zener diode will allow the circuit to easily work up to 450V.

The input current drawn from the VIN pin is a sum of the 1.0mA current drawn by the internal circuit and the current drawn by the GATE driver. The GATE driver depends on the switching frequency and the GATE charge of the external FET).

$$I_{IN} \approx 1.0\text{mA} + Q_g \cdot f_s$$

In the above equation,  $f_s$  is the switching frequency and  $Q_g$  is the GATE charge of the external FET (which can be obtained from the data sheet of the FET).

### 3.2 Current Sense

The current sense input of the HV9910B goes to the non-inverting inputs of two comparators. The inverting terminal of one comparator is tied to an internal 250mV reference, whereas the inverting terminal of the other comparator is connected to the LD pin. The outputs of both these comparators are fed into an OR GATE and the output of the OR GATE is fed into the reset pin of the flip-flop. Thus, the comparator which has the lowest voltage at the inverting terminal determines when the GATE output is turned off.

The outputs of the comparators also include a 150-280ns blanking time which prevents spurious turn-offs of the external FET due to the turn-on spike normally present in peak current mode control. In rare cases, this internal blanking might not be enough to filter out the turn-on spike. In these cases, an external RC filter needs to be added between the external sense resistor (RCS) and the CS pin.

Please note that the comparators are fast with a typical 80ns response time. Hence these comparators are more susceptible to be triggered by noise than the comparators of the HV9910. A proper layout minimizing external inductances will prevent false triggering of these comparators.

### 3.3 Oscillator

The oscillator in the HV9910B is controlled by a single resistor connected at the RT pin. The equation governing the oscillator time period  $t_{OSC}$  is given by:

$$t_{OSC}(\mu s) = \frac{R_T(k\Omega) + 22}{25}$$

If the resistor is connected between RT and GND, HV9910B operates in a constant frequency mode and the above equation determines the time-period. If the resistor is connected between RT and GATE, the HV9910B operates in a constant off-time mode and the above equation determines the off-time.

### 3.4 Gate Output

The GATE output of the HV9910B is used to drive an external FET. It is recommended that the GATE charge of the external FET be less than 25nC for switching frequencies  $\leq 100\text{kHz}$  and less than 15nC for switching frequencies  $> 100\text{kHz}$ .

### 3.5 Linear Dimming

The Linear Dimming pin is used to control the LED current. There are two cases when it may be necessary to use the Linear Dimming pin.

1. In some cases, when using the internal 250mV, it may not be possible to find the exact RCS value required to obtain the LED current. In these cases, an external voltage divider from the VDD pin can be connected to the LD pin to obtain a voltage (less than 250mV) corresponding to the desired voltage across  $R_{CS}$ .
2. Linear dimming may be desired to adjust the current level to reduce the intensity of the LEDs. In these cases, an external 0-250mV voltage can be connected to the LD pin to adjust the LED current during operation.

To use the internal 250mV, the LD pin can be connected to VDD.

**Note:** Although the LD pin can be pulled to GND, the output current will not go to zero. This is due to the presence of a minimum on-time, which is equal to the sum of the blanking time and the delay to output time, or about 450ns. This minimum on-time causes the FET to be on for a minimum of 450ns, and thus the LED current when LD = GND is not zero. This current is also dependent on the input voltage, inductance value, forward voltage of the LEDs, and circuit parasitics. To get zero LED current, the PWMD pin has to be used.

### 3.6 PWM Dimming

PWM Dimming can be achieved by driving the PWMD pin with a low frequency square wave signal. When the PWM signal is zero, the GATE driver is turned off; when the PWMD signal is high, the GATE driver is enabled. The PWMD signal does not turn off the other parts of the IC, therefore, the response of the HV9910B to the PWMD signal is almost instantaneous. The rate of rise and fall of the LED current is thus determined solely by the rise and fall times of the inductor current.

To disable PWM dimming and enable the HV9910B permanently, connect the PWMD pin to VDD.

# HV9910B

FIGURE 3-1: INTERNAL BLOCK DIAGRAM

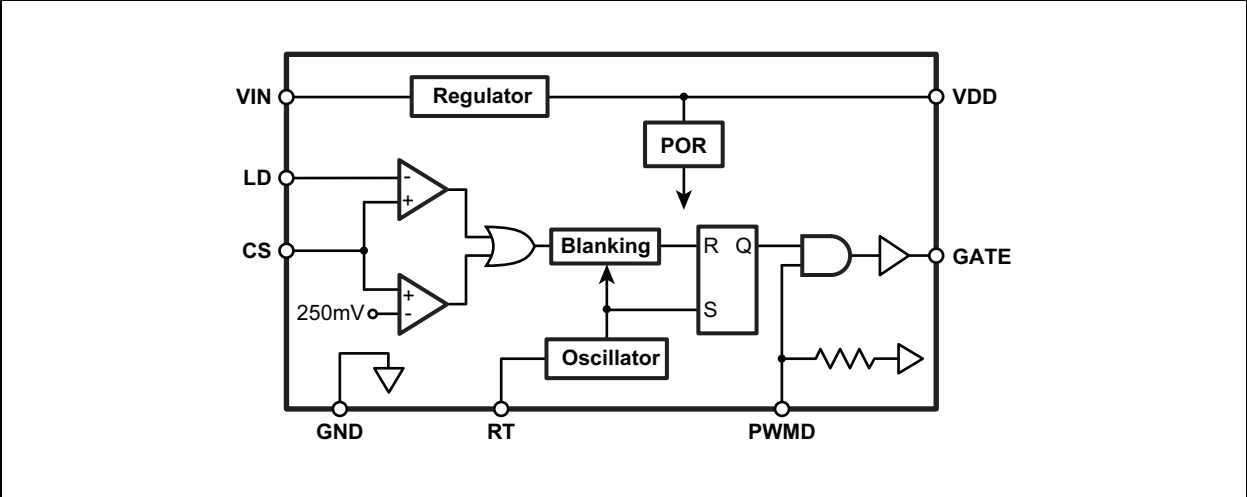

## 4.0 PACKAGING INFORMATION

### 4.1 Package Marking Information

8-lead SOIC

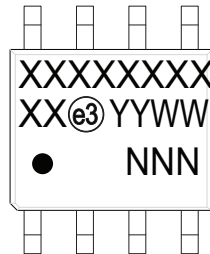

Example

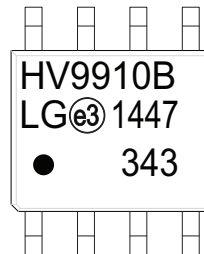

16-lead SOIC

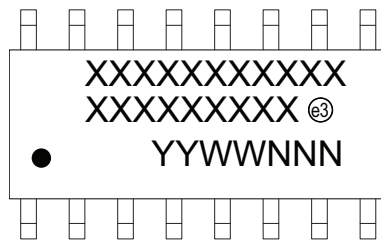

Example



<b>Legend:</b>	XX...X	Product Code or Customer-specific information
	Y	Year code (last digit of calendar year)
	YY	Year code (last 2 digits of calendar year)
	WW	Week code (week of January 1 is week '01')
	NNN	Alphanumeric traceability code
	<sup>(e3)</sup>	Pb-free JEDEC <sup>®</sup> designator for Matte Tin (Sn)
	*	This package is Pb-free. The Pb-free JEDEC designator ( <sup>(e3)</sup> ) can be found on the outer packaging for this package.

**Note:** In the event the full Microchip part number cannot be marked on one line, it will be carried over to the next line, thus limiting the number of available characters for product code or customer-specific information. Package may or not include the corporate logo.

# HV9910B

## 8-Lead SOIC (Narrow Body) Package Outline (LG/TG) 4.90x3.90mm body, 1.75mm height (max), 1.27mm pitch

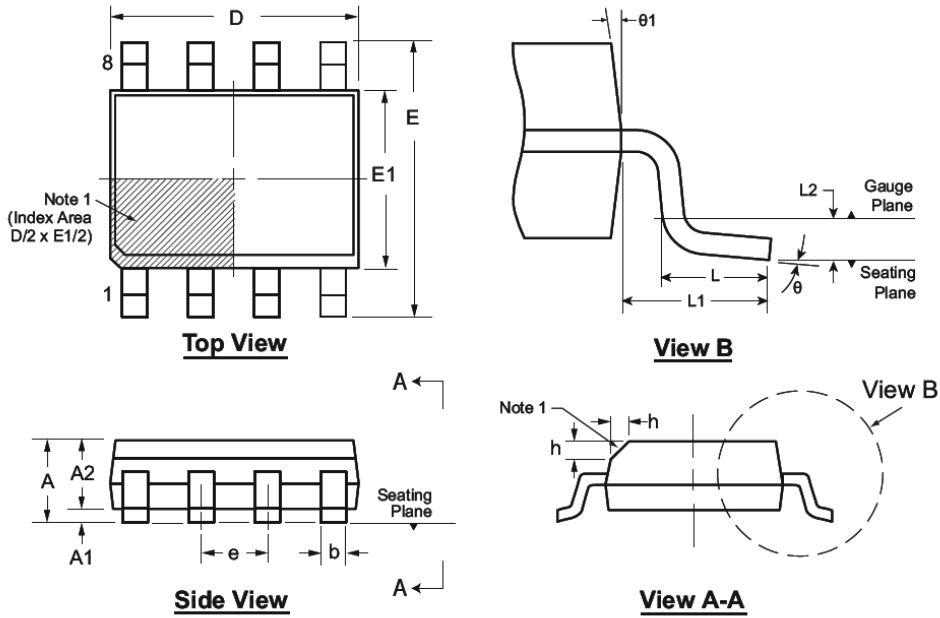

Note: For the most current package drawings, see the Microchip Packaging Specification at [www.microchip.com/packaging](http://www.microchip.com/packaging).

**Note:**

1. This chamfer feature is optional. A Pin 1 identifier must be located in the index area indicated. The Pin 1 identifier can be: a molded mark/identifier; an embedded metal marker; or a printed indicator.

Symbol	A	A1	A2	b	D	E	E1	e	h	L	L1	L2	$\theta$	$\theta 1$		
Dimension (mm)	MIN	1.35*	0.10	1.25	0.31	4.80*	5.80*	3.80*	1.27 BSC	0.25	0.40	1.04 REF	0.25 BSC	0°	5°	
	NOM	-	-	-	-	4.90	6.00	3.90		-	-		-	-	-	-
	MAX	1.75	0.25	1.65*	0.51	5.00*	6.20*	4.00*		0.50	1.27		-	-	8°	15°

JEDEC Registration MS-012, Variation AA, Issue E, Sept. 2005.

\* This dimension is not specified in the JEDEC drawing.

Drawings are not to scale.

## 16-Lead SOIC (Narrow Body) Package Outline (NG) 9.90x3.90mm body, 1.75mm height (max), 1.27mm pitch

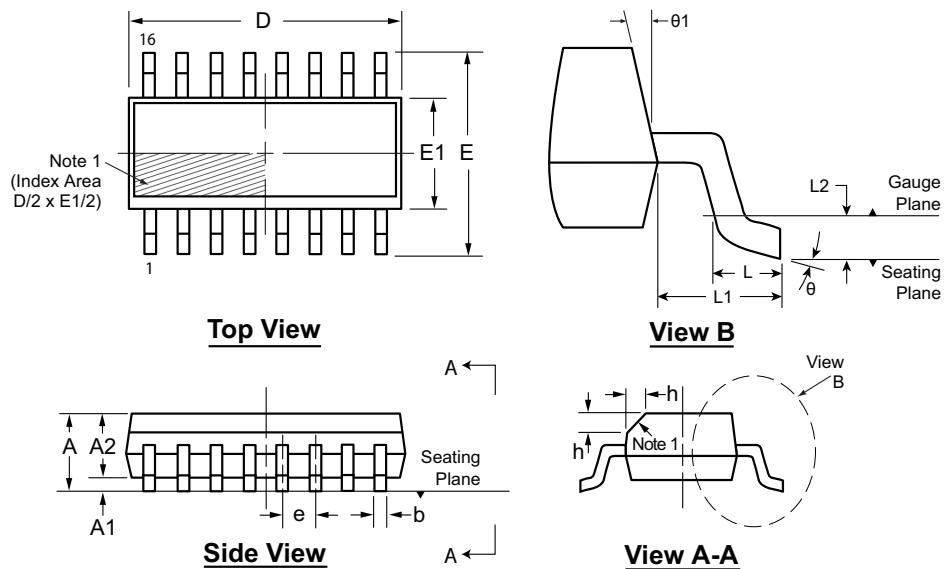

Note: For the most current package drawings, see the Microchip Packaging Specification at [www.microchip.com/packaging](http://www.microchip.com/packaging).

**Note:**

1. This chamfer feature is optional. If it is not present, then a Pin 1 identifier must be located in the index area indicated. The Pin 1 identifier can be: a molded mark/identifier; an embedded metal marker; or a printed indicator.

Symbol	A	A1	A2	b	D	E	E1	e	h	L	L1	L2	$\theta$	$\theta_1$
Dimension (mm)	MIN	1.35*	0.10	1.25	0.31	9.80*	5.80*	3.80*	0.25	0.40	1.04 REF	0.25 BSC	0°	5°
	NOM	-	-	-	-	9.90	6.00	3.90	-	-			-	-
	MAX	1.75	0.25	1.65*	0.51	10.00*	6.20*	4.00*	0.50	1.27			8°	15°

JEDEC Registration MS-012, Variation AC, Issue E, Sept. 2005.

\* This dimension is not specified in the JEDEC drawing.

Drawings are not to scale.

# HV9910B

---

## APPENDIX A: REVISION HISTORY

### Revision A (January 2015)

- Update file to new format

## PRODUCT IDENTIFICATION SYSTEM

To order or obtain information, e.g., on pricing or delivery, refer to the factory or the listed sales office.

<u>PART NO.</u>	<u>XX</u>	-	<u>X</u>	-	<u>X</u>
Device	Package Options		Environmental		Media Type
Device:	HV9910B= Universal High-Brightness LED Driver				
Package:	LG	=	8-lead SOIC		
	NG	=	16-lead SOIC		
Environmental	G	=	Lead (Pb)-free/ROHS-compliant package		
Media Type:	(blank)	=	3300/reel for LG package, 45/Tube for NG package		
	M901	=	2600/reel for NG package		
	M934	=	2600/reel for NG package		
<b>Note:</b>	For Media Types M901 and M934, the base quantity for tape and reel was standardized to 2600/reel. Both options will result in delivery of the same number of parts/reel.				

### Examples:

- a) HV9910BLG-G: 8-lead SOIC package, 3300/reel.
- b) HV9910BNG-G: 16-lead SOIC package, 45/tube
- c) HV9910BNG-G-M901: 16-lead SOIC package, 2600/reel.
- d) HV9910BNG-G-M934: 16-lead SOIC package, 2600/reel.

---

---

**Note the following details of the code protection feature on Microchip devices:**

- Microchip products meet the specification contained in their particular Microchip Data Sheet.
- Microchip believes that its family of products is one of the most secure families of its kind on the market today, when used in the intended manner and under normal conditions.
- There are dishonest and possibly illegal methods used to breach the code protection feature. All of these methods, to our knowledge, require using the Microchip products in a manner outside the operating specifications contained in Microchip's Data Sheets. Most likely, the person doing so is engaged in theft of intellectual property.
- Microchip is willing to work with the customer who is concerned about the integrity of their code.
- Neither Microchip nor any other semiconductor manufacturer can guarantee the security of their code. Code protection does not mean that we are guaranteeing the product as “unbreakable.”

Code protection is constantly evolving. We at Microchip are committed to continuously improving the code protection features of our products. Attempts to break Microchip's code protection feature may be a violation of the Digital Millennium Copyright Act. If such acts allow unauthorized access to your software or other copyrighted work, you may have a right to sue for relief under that Act.

Information contained in this publication regarding device applications and the like is provided only for your convenience and may be superseded by updates. It is your responsibility to ensure that your application meets with your specifications. MICROCHIP MAKES NO REPRESENTATIONS OR WARRANTIES OF ANY KIND WHETHER EXPRESS OR IMPLIED, WRITTEN OR ORAL, STATUTORY OR OTHERWISE, RELATED TO THE INFORMATION, INCLUDING BUT NOT LIMITED TO ITS CONDITION, QUALITY, PERFORMANCE, MERCHANTABILITY OR FITNESS FOR PURPOSE. Microchip disclaims all liability arising from this information and its use. Use of Microchip devices in life support and/or safety applications is entirely at the buyer's risk, and the buyer agrees to defend, indemnify and hold harmless Microchip from any and all damages, claims, suits, or expenses resulting from such use. No licenses are conveyed, implicitly or otherwise, under any Microchip intellectual property rights.

#### **Trademarks**

The Microchip name and logo, the Microchip logo, dsPIC, FlashFlex, KEELOQ, KEELOQ logo, MPLAB, PIC, PICmicro, PICSTART, PIC<sup>32</sup> logo, rPIC, SST, SST Logo, SuperFlash and UNI/O are registered trademarks of Microchip Technology Incorporated in the U.S.A. and other countries.

FilterLab, Hampshire, HI-TECH C, Linear Active Thermistor, MTP, SEEVAL and The Embedded Control Solutions Company are registered trademarks of Microchip Technology Incorporated in the U.S.A.

Silicon Storage Technology is a registered trademark of Microchip Technology Inc. in other countries.

Analog-for-the-Digital Age, Application Maestro, BodyCom, chipKIT, chipKIT logo, CodeGuard, dsPICDEM, dsPICDEM.net, dsPICworks, dsSPEAK, ECAN, ECONOMONITOR, FanSense, HI-TIDE, In-Circuit Serial Programming, ICSP, Mindi, MiWi, MPASM, MPF, MPLAB Certified logo, MPLIB, MPLINK, mTouch, Omniclient Code Generation, PICC, PICC-18, PICDEM, PICDEM.net, PICkit, PICtail, REAL ICE, rLAB, Select Mode, SQI, Serial Quad I/O, Total Endurance, TSHARC, UniWinDriver, WiperLock, ZENA and Z-Scale are trademarks of Microchip Technology Incorporated in the U.S.A. and other countries.

SQTP is a service mark of Microchip Technology Incorporated in the U.S.A.

GestIC and ULPP are registered trademarks of Microchip Technology Germany II GmbH & Co. KG, a subsidiary of Microchip Technology Inc., in other countries.

All other trademarks mentioned herein are property of their respective companies.

© 2015, Microchip Technology Incorporated, Printed in the U.S.A., All Rights Reserved.

 Printed on recycled paper.

ISBN: 978-1-63277-025-7

*Microchip received ISO/TS-16949:2009 certification for its worldwide headquarters, design and wafer fabrication facilities in Chandler and Tempe, Arizona; Gresham, Oregon and design centers in California and India. The Company's quality system processes and procedures are for its PIC<sup>®</sup> MCUs and dsPIC<sup>®</sup> DSCs, KEELOQ<sup>®</sup> code hopping devices, Serial EEPROMs, microperipherals, nonvolatile memory and analog products. In addition, Microchip's quality system for the design and manufacture of development systems is ISO 9001:2000 certified.*

**QUALITY MANAGEMENT SYSTEM**  
**CERTIFIED BY DNV**  
**== ISO/TS 16949 ==**



# MICROCHIP

## Worldwide Sales and Service

### AMERICAS

#### Corporate Office

2355 West Chandler Blvd.  
Chandler, AZ 85224-6199  
Tel: 480-792-7200  
Fax: 480-792-7277  
Technical Support:  
<http://www.microchip.com/support>

#### Web Address:

[www.microchip.com](http://www.microchip.com)

#### Atlanta

Duluth, GA  
Tel: 678-957-9614  
Fax: 678-957-1455

#### Austin, TX

Tel: 512-257-3370

#### Boston

Westborough, MA  
Tel: 774-760-0087  
Fax: 774-760-0088

#### Chicago

Itasca, IL  
Tel: 630-285-0071  
Fax: 630-285-0075

#### Cleveland

Independence, OH  
Tel: 216-447-0464  
Fax: 216-447-0643

#### Dallas

Addison, TX  
Tel: 972-818-7423  
Fax: 972-818-2924

#### Detroit

Novi, MI  
Tel: 248-848-4000

#### Houston, TX

Tel: 281-894-5983  
Indianapolis

#### Noblesville, IN

Tel: 317-773-8323  
Fax: 317-773-5453

#### Los Angeles

Mission Viejo, CA  
Tel: 949-462-9523  
Fax: 949-462-9608

#### New York, NY

Tel: 631-435-6000

#### San Jose, CA

Tel: 408-735-9110

#### Canada - Toronto

Tel: 905-673-0699  
Fax: 905-673-6509

### ASIA/PACIFIC

#### Asia Pacific Office

Suites 3707-14, 37th Floor  
Tower 6, The Gateway  
Harbour City, Kowloon

#### Hong Kong

Tel: 852-2943-5100  
Fax: 852-2401-3431

#### Australia - Sydney

Tel: 61-2-9868-6733  
Fax: 61-2-9868-6755

#### China - Beijing

Tel: 86-10-8569-7000  
Fax: 86-10-8528-2104

#### China - Chengdu

Tel: 86-28-8665-5511  
Fax: 86-28-8665-7889

#### China - Chongqing

Tel: 86-23-8980-9588  
Fax: 86-23-8980-9500

#### China - Dongguan

Tel: 86-769-8702-9880

#### China - Hangzhou

Tel: 86-571-8792-8115  
Fax: 86-571-8792-8116

#### China - Hong Kong SAR

Tel: 852-2943-5100  
Fax: 852-2401-3431

#### China - Nanjing

Tel: 86-25-8473-2460  
Fax: 86-25-8473-2470

#### China - Qingdao

Tel: 86-532-8502-7355  
Fax: 86-532-8502-7205

#### China - Shanghai

Tel: 86-21-5407-5533  
Fax: 86-21-5407-5066

#### China - Shenyang

Tel: 86-24-2334-2829  
Fax: 86-24-2334-2393

#### China - Shenzhen

Tel: 86-755-8864-2200  
Fax: 86-755-8203-1760

#### China - Wuhan

Tel: 86-27-5980-5300  
Fax: 86-27-5980-5118

#### China - Xian

Tel: 86-29-8833-7252  
Fax: 86-29-8833-7256

### ASIA/PACIFIC

#### China - Xiamen

Tel: 86-592-2388138  
Fax: 86-592-2388130

#### China - Zhuhai

Tel: 86-756-3210040  
Fax: 86-756-3210049

#### India - Bangalore

Tel: 91-80-3090-4444  
Fax: 91-80-3090-4123

#### India - New Delhi

Tel: 91-11-4160-8631  
Fax: 91-11-4160-8632

#### India - Pune

Tel: 91-20-3019-1500

#### Japan - Osaka

Tel: 81-6-6152-7160  
Fax: 81-6-6152-9310

#### Japan - Tokyo

Tel: 81-3-6880-3770  
Fax: 81-3-6880-3771

#### Korea - Daegu

Tel: 82-53-744-4301  
Fax: 82-53-744-4302

#### Korea - Seoul

Tel: 82-2-554-7200  
Fax: 82-2-558-5932 or  
82-2-558-5934

#### Malaysia - Kuala Lumpur

Tel: 60-3-6201-9857  
Fax: 60-3-6201-9859

#### Malaysia - Penang

Tel: 60-4-227-8870  
Fax: 60-4-227-4068

#### Philippines - Manila

Tel: 63-2-634-9065  
Fax: 63-2-634-9069

#### Singapore

Tel: 65-6334-8870  
Fax: 65-6334-8850

#### Taiwan - Hsin Chu

Tel: 886-3-5778-366  
Fax: 886-3-5770-955

#### Taiwan - Kaohsiung

Tel: 886-7-213-7828

#### Taiwan - Taipei

Tel: 886-2-2508-8600  
Fax: 886-2-2508-0102

#### Thailand - Bangkok

Tel: 66-2-694-1351  
Fax: 66-2-694-1350

### EUROPE

#### Austria - Wels

Tel: 43-7242-2244-39  
Fax: 43-7242-2244-393

#### Denmark - Copenhagen

Tel: 45-4450-2828  
Fax: 45-4485-2829

#### France - Paris

Tel: 33-1-69-53-63-20  
Fax: 33-1-69-30-90-79

#### Germany - Dusseldorf

Tel: 49-2129-3766400

#### Germany - Munich

Tel: 49-89-627-144-0  
Fax: 49-89-627-144-44

#### Germany - Pforzheim

Tel: 49-7231-424750

#### Italy - Milan

Tel: 39-0331-742611  
Fax: 39-0331-466781

#### Italy - Venice

Tel: 39-049-7625286

#### Netherlands - Drunen

Tel: 31-416-690399  
Fax: 31-416-690340

#### Poland - Warsaw

Tel: 48-22-3325737

#### Spain - Madrid

Tel: 34-91-708-08-90  
Fax: 34-91-708-08-91

#### Sweden - Stockholm

Tel: 46-8-5090-4654



#### UK - Wokingham

Tel: 44-118-921-5800  
Fax: 44-118-921-5820

01/27/15

## Looking for pricing, stock, or lifecycle information?

Click below to explore more details on WIN SOURCE:

-  [View HV9910BNG-G-M901 on WIN SOURCE](#)
-  [Microchip Technology](#) Information

## Optimize Your Supply Chain with WIN SOURCE Solutions

-  Global Sourcing Solution
-  Obsolete Management
-  Cost Control Management
-  Shortage Management
-  Alternative Solution
-  Excess Inventory Management